

HD356 Service Parts

This parts list contains the service parts for the HD356 dispenser.

Use caution when ordering parts. Double-check the model number to be certain that the parts ordered are the ones for that machine.

Table Of Contents

Panels	Page 2
Cabinet	Page 3
Lower Cabinet Parts	Page 4
Hopper and Rotor	Page 5
Dispensing Components	Page 6
Gear Drive	Page 7
Control Box	Page 8
Coin and Card Mechanisms	Page 9
Wiring Diagrams	Page 10

HD356 Service Parts

Panels

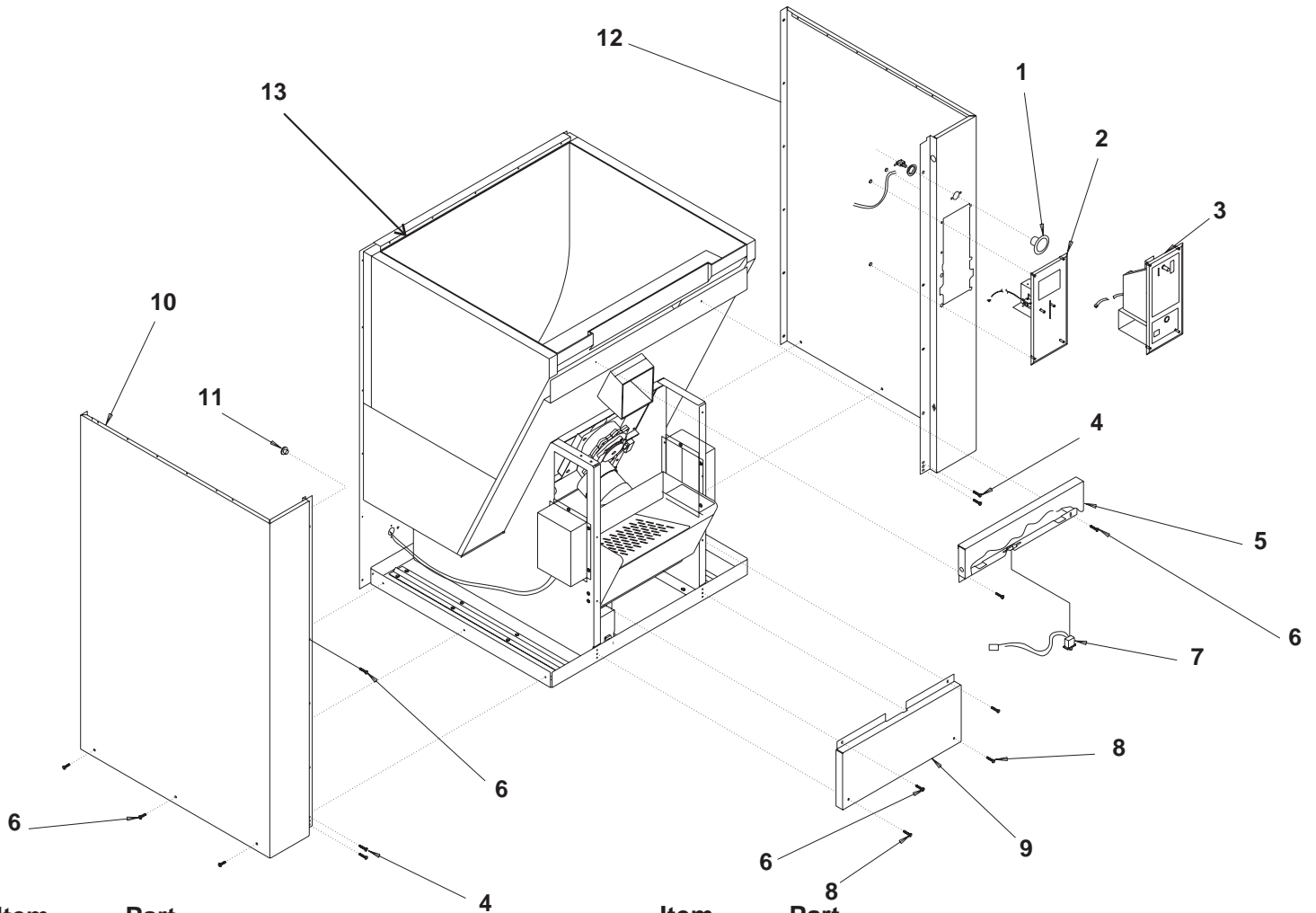

Item Number	Part Number	Description	Item Number	Part Number	Description
1	02-3773-01	Push button switch	11	12-0629-01	Strain relief
2	KCARD	Card kit	12	A37393-015	Grey right side panel for coin or card kit
3	02-3114-01	Coin mech		A37393-002	SS right side panel for coin or card kit - A series
4	03-1531-01	Screw		A37637-001	SS right side panel for coin or card kit - C series
5	A32625-015	Grey upper front panel		A37393-016	Grey right side panel for button only A series
	A32625-002	SS upper front panel		A37393-003	SS right side panel for button only A series
6	03-1638-03	Screw		A37637-002	SS right side panel for button, C series
7	12-1276-01	Switch			
8	03-1419-28	Screw	13	A34726-015	Grey back panel
9	A32620-015	Grey panel, bottom		A34726-015	SS back panel
	A32620-002	SS panel, bottom			
10	A32622-015	Grey left side panel			
	A32622-002	SS left side panel - A series			
	A37638-001	SS left side panel - C series			

HD356 Service Parts

Cabinet

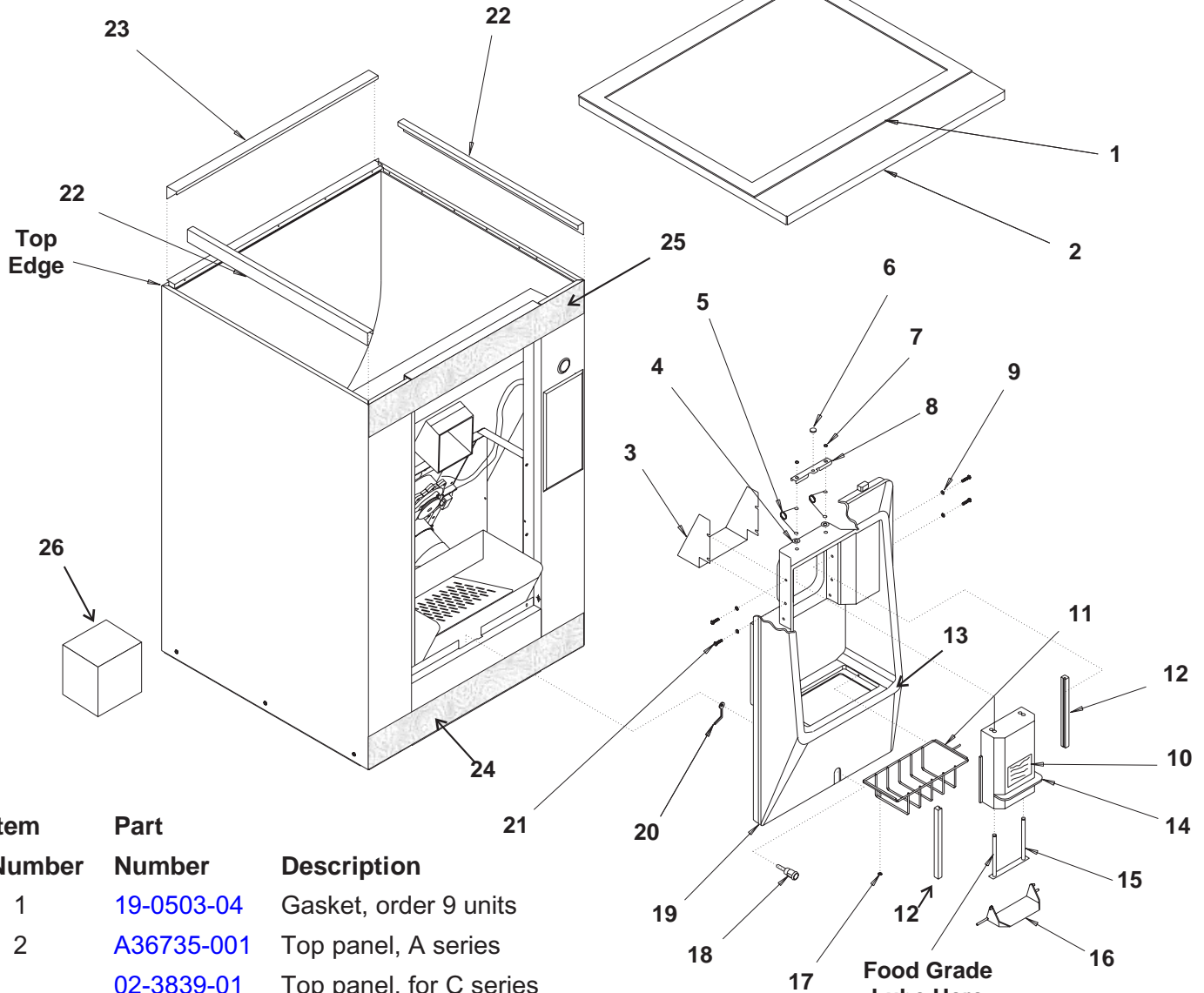

Item Number	Part Number	Description
1	19-0503-04	Gasket, order 9 units
2	A36735-001	Top panel, A series
	02-3839-01	Top panel, for C series
3	A25377-001	Shield
4	03-1407-07	Washer
5	02-2097-01	Spring
6	13-0876-01	Bumper
7	03-1539-03	Retainer
8	A36487-001	Bar
9	03-1407-02	Washer
10	17-2604-01	Button disp. decal
11	02-3018-01	Grill
12	02-3137-01	Track
13	KIB200	Optional ice baffle kit
14	02-1994-20	Dispensing hood & label
15	A23674-001	Return assembly

Item Number	Part Number	Description
16	02-1995-01	Ice chute gate
17	03-1651-01	Nut
18	A35618-001	Lock Kit
	02-3263-01	Key
19	02-2901-04	Sink
20	no number	Latch, part of item 18
21	03-0727-09	Thumb screw
22	A32818-001	Side bracket
23	A32817-001	Rear bracket
24	17-2598-02	Bottom label
25	17-2598-01	Top label
26	KLP7	Leg kit (4 legs)

HD356 Service Parts

Lower Cabinet Parts

Item Number	Part Number	Description
1	03-1645-01	Screw
2	A32616-015	Brace
3	A34727-015	Base
4	A38021-001	Drain pan & fitting
5	12-2333-21	50 Hz transformer
6	03-0571-00	Screw
7	A32617-015	Bin support left
8	A32617-016	Bin support right
9	A35416-001	Drain chute
10	A35542-001	Dam screen
11	02-3692-21	Drain fitting
12	A33203-001	Drain tube
	02-2814-08	Hose clamp

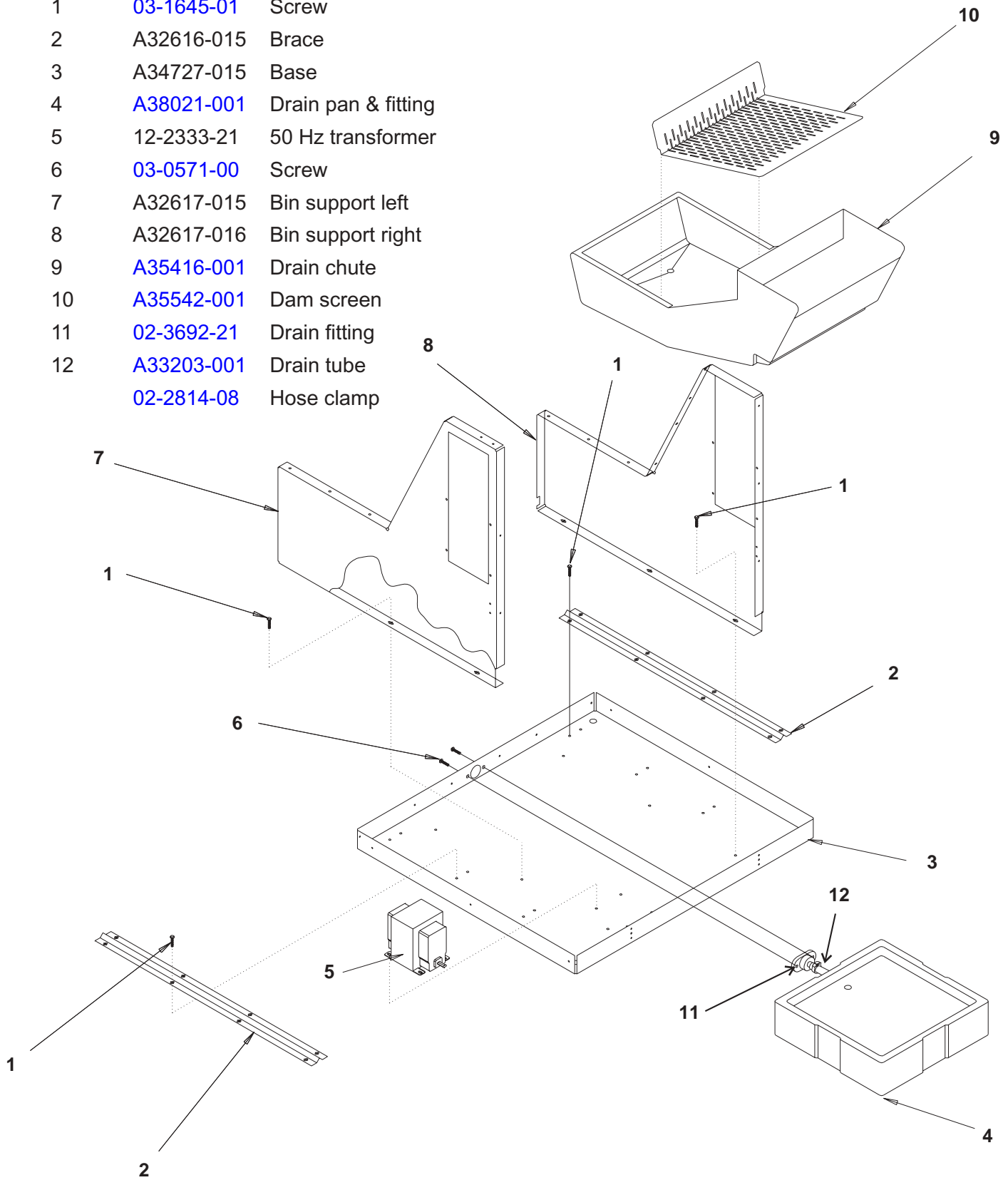

HD356 Service Parts

Hopper and Rotor

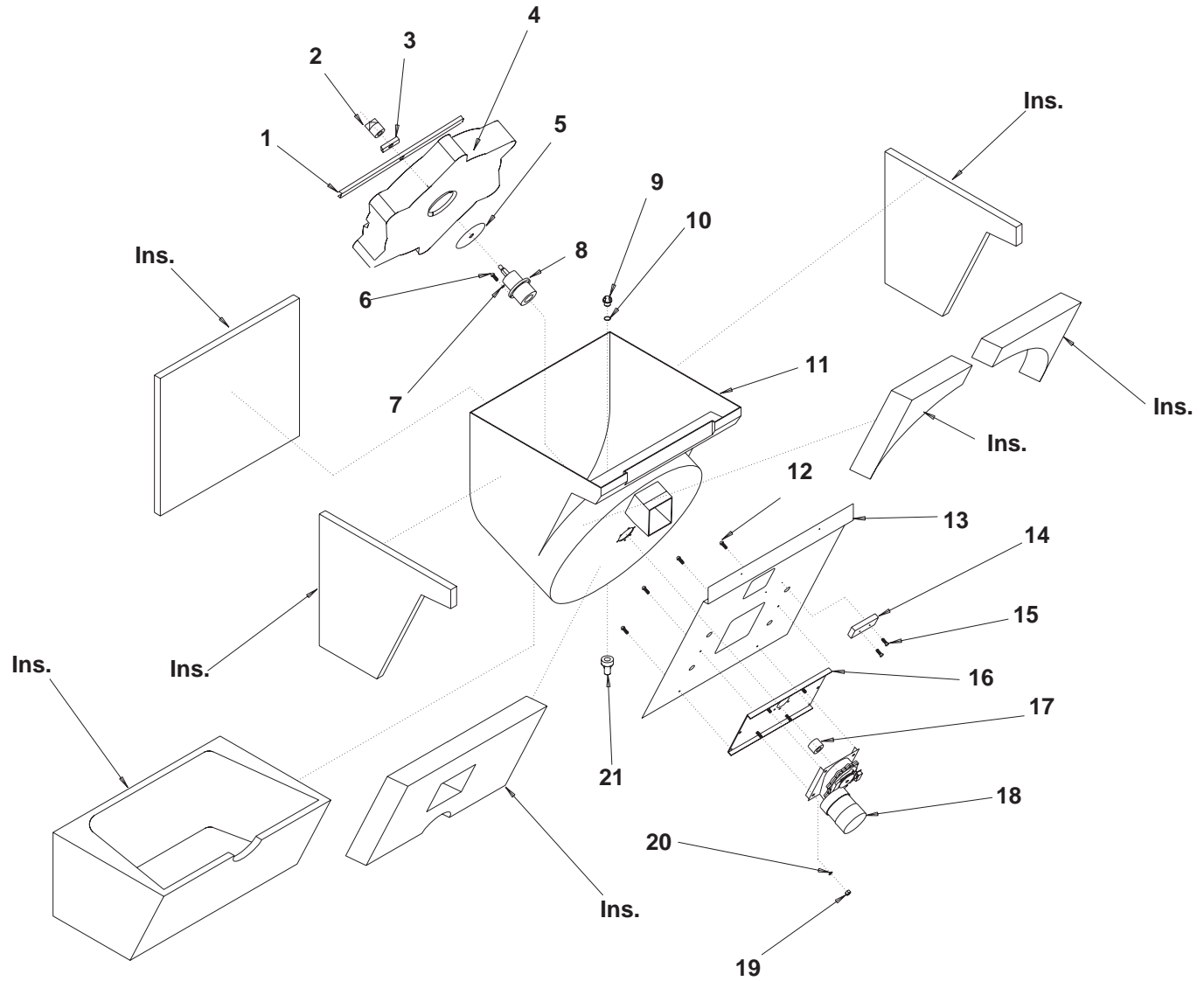

Item Number	Part Number	Description	Item Number	Part Number	Description
1	A37380-001	Rotor channel	12	03-1645-01	Screw
2	02-3221-01	Rotor nut	13	A32653-015	Grey retainer
3	02-3768-01	Drive block	14	12-2175-01	Terminal block
4	A37343-002	Rotor	15	03-1404-13	Screw
5	03-1725-01	Washer	16	A32644-015	Gear motor support
6	03-1403-72	Screw	17	15-0575-01	Coupling
7	03-1417-09	Washer	18	A28155-021	Gear and motor
8	02-3754-20	Shaft and housing	19	03-1406-12	Hex nut
9	02-2809-01	Drain top	20	03-1410-05	Lockwasher
10	13-0617-11	O ring	21	02-2692-01	Drain
11	02-2911-02	Storage bin			

HD356 Service Parts

Dispensing Components

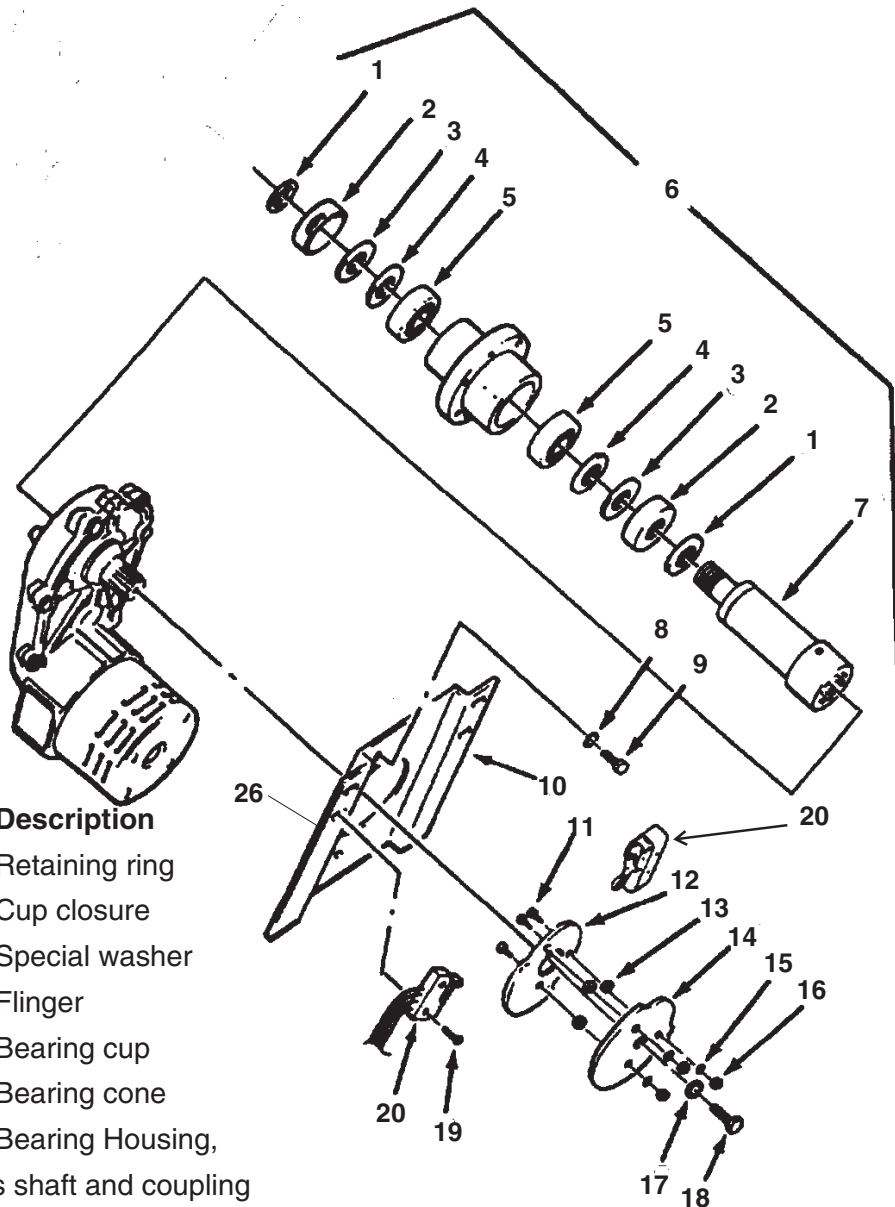

Item Number	Part Number	Description
1	03-1516-01	Retaining ring
2	02-2026-01	Cup closure
3	03-1408-27	Special washer
4	02-2027-01	Flinger
5	02-2186-01	Bearing cup
	02-2186-02	Bearing cone
6	02-3754-20	Bearing Housing, includes shaft and coupling
7	02-3757-20	Shaft and coupling kit
8	03-1410-04	Lockwasher
9	03-1405-15	Screw
10	A29732-001	Bracket, double cam
11	03-1403-18	Screw
12*	A37852-001	Cam #2, bottom - by case
13	A29733-001	Spacer
14*	A37851-001	Cam (top) all
15	03-1410-07	Lockwasher
16	03-1406-03	Nut
17	03-1410-03	Lockwasher
18	03-1405-03	Screw
19	03-1403-09	Screw
20	12-2365-01	Cam switch
21	03-0886-00	Speed nut

*Replace items 12 and 14 as a set in HD356s built prior to date code 05R.

HD356 Service Parts

Gear Drive

Item Number	Part Number	Description
1	02-1503-00	Grease Seal (2)
2	03-1408-21	Washer
3	03-1408-04	Washer
4	02-2446-01	Output shaft
5	03-1515-03	Retaining ring
6	03-1602-01	Woodruff key
7	02-2444-01	Output gear
8	02-1505-00	O-Ring
9	03-0774-11	Roll pin
10	A28167-001	Gear case assembly
11	03-1408-39	Washer
12	03-1408-40	Washer shim
13	02-2441-01	Second gear, third pinion
14	03-1408-01	Washer
15	03-1408-38	Washer
16	02-2448-01	First gear, second pinion
17	A28189-001	Gear box cover
18	02-1504-00	Grease seal
19	02-1501-00	Bearing
20	03-1408-08	Washer
21	A28160-002	Rotor assembly
22	12-2036-01	Stator (115/60/1)
23	A28168-001	Cooling fan
24	A38487-020	Motor housing
25	A28155-021	Complete gear Motor without cams or bracket.
26	18-3701-01	Capacitor

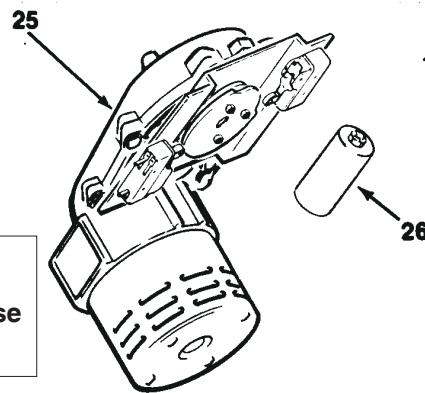
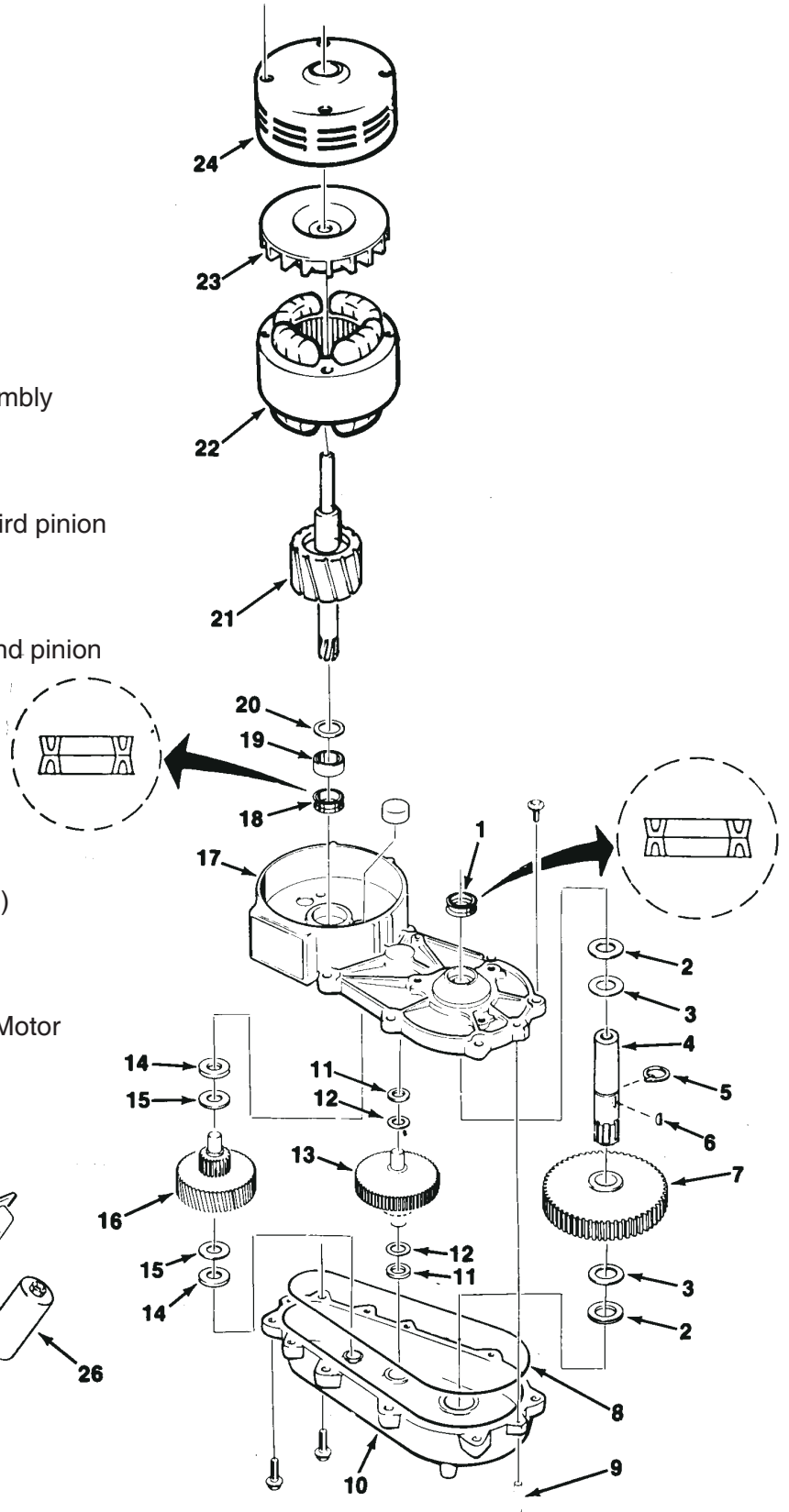

Note: 16 oz. can of grease is P/N 19-0472-20. Gear case capacity is 12 oz.

HD356 Service Parts

Control Box

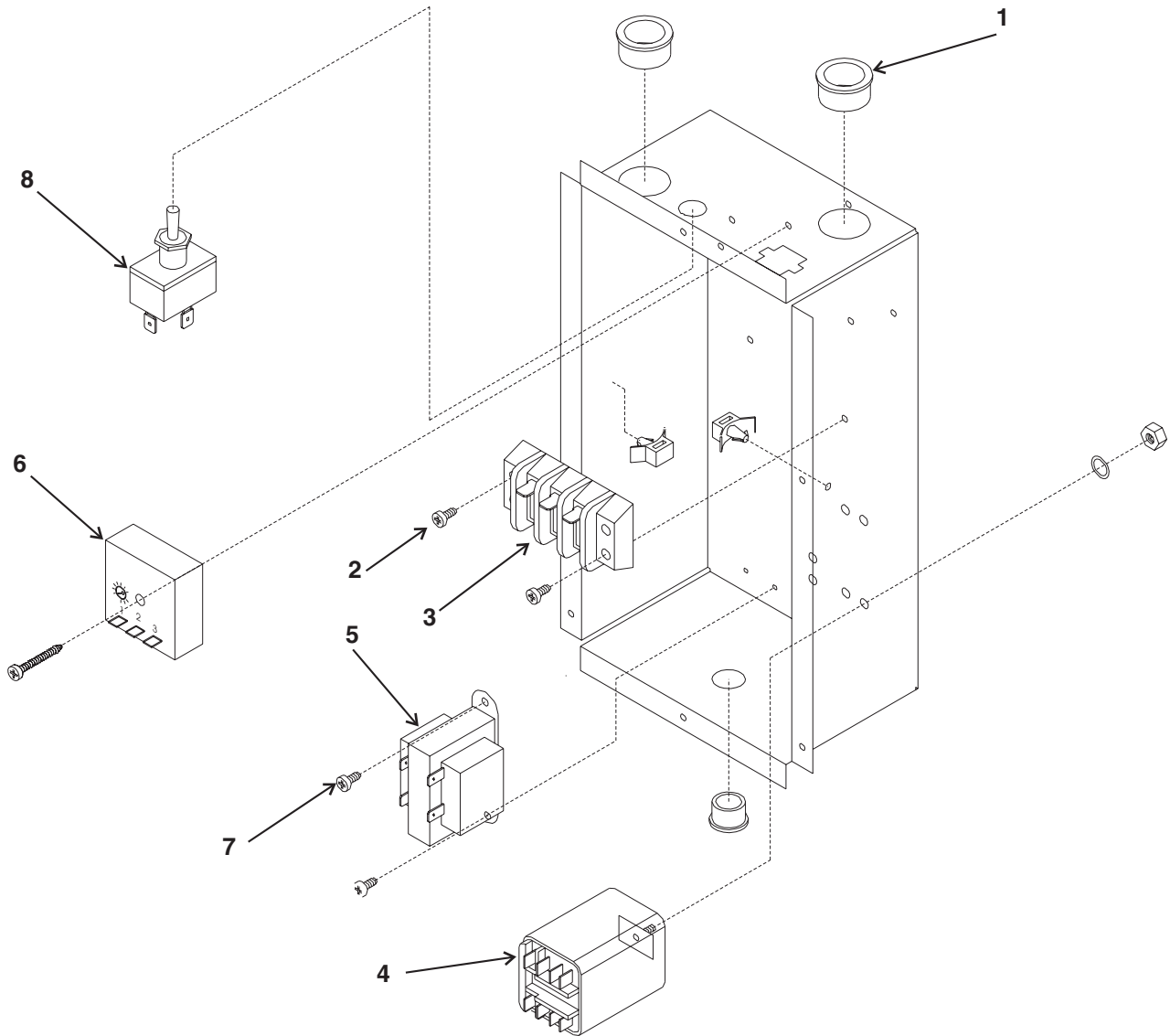

Item Number	Part Number	Description
1	12-1213-10	Snap bushing
2	03-1531-08	Screw
3	12-2114-01	Terminal strip
4	12-2090-02	Relay
5	12-2836-01	Transformer 115 to 24
6	12-2631-01	Recycling timer
8	03-1404-14	Screw
9	12-0426-01	Toggle switch
10	A35398-015	Control box cover (not shown)

HD356 Service Parts

Coin and Card Mechanisms

02-3114-01 - Complete coin mech

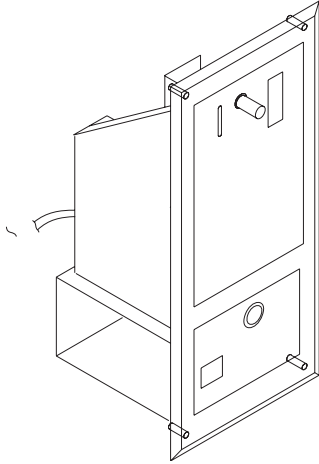

Item Number	Part Number	Description
1	02-3114-20	Lock kit (includes key & lock)
2	02-3114-21	Coin return kit (solenoid)
3	02-3114-22	Cash box
4	02-3114-23	Coin switch
5	17-2614-01	Label

KCARD

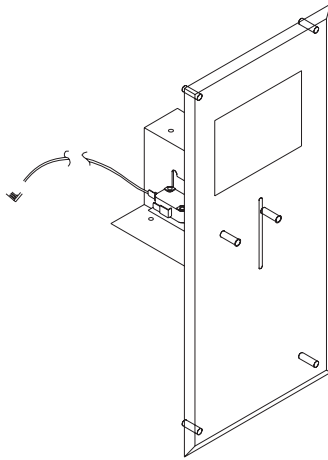

Item Number	Part Number	Description
1	A29708-003	Cover plate, SS
	A29708-015	Cover plate, Grey
2	12-2450-01	Microswitch
3	17-2144-01	Label

Relay Box for Coin Mechanism Models

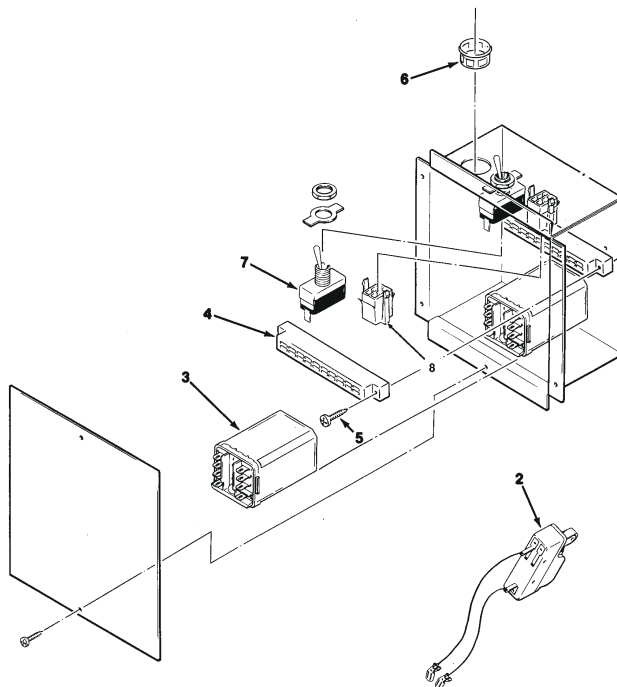

Item Number	Part Number	Description
1	No number	Relay box
2	12-0876-00	Cam switch
3	12-2090-02	Relay
4	12-2175-01	Terminal block
5	03-1403-08	Screw
6	12-1213-10	Bushing
7	12-0426-01	Switch
8	12-2187-02	Plug & harness

HD356 Service Parts

Schematic Diagram - Button Dispensing

VEND SWITCH

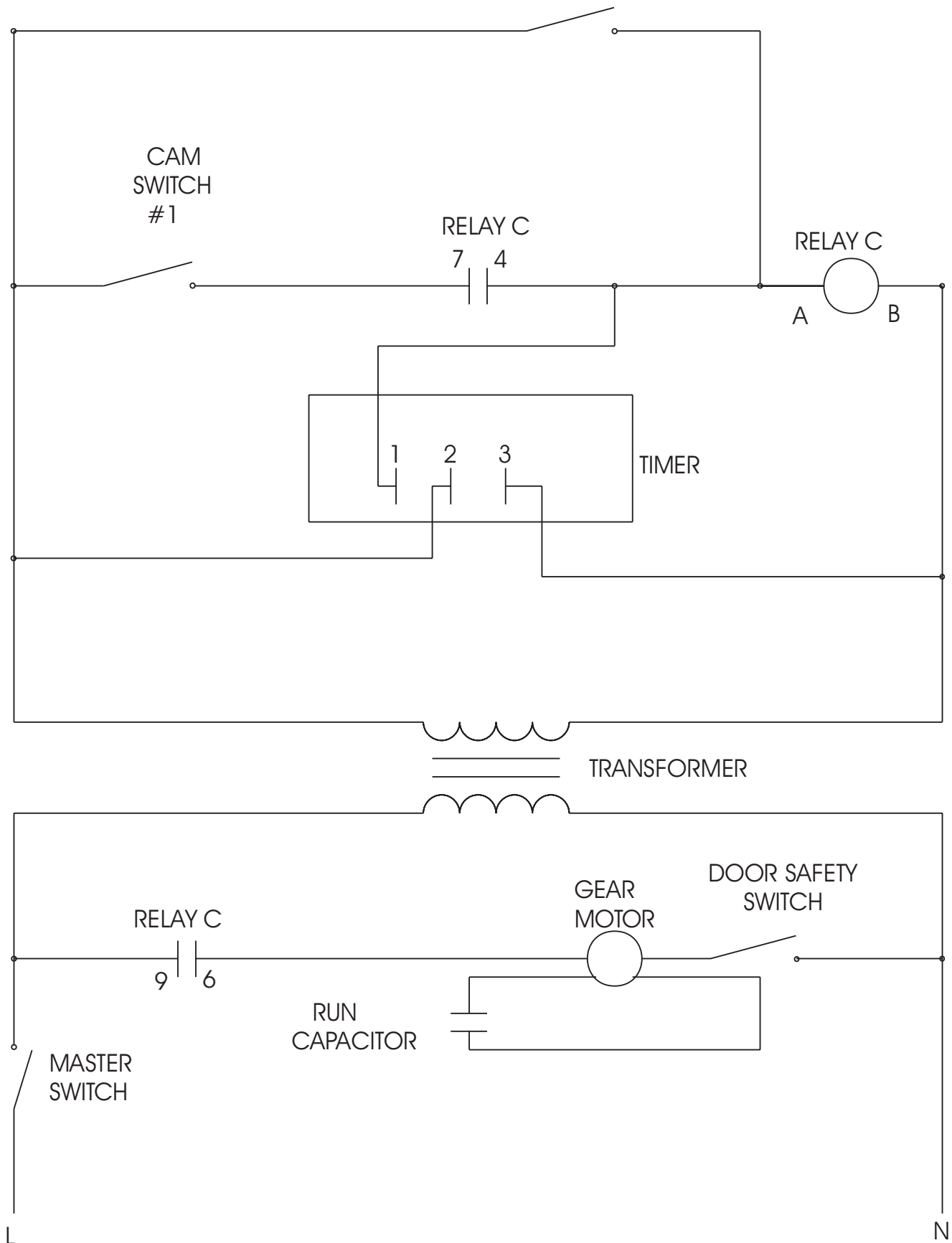

HD356 Service Parts

Wiring Diagram - Button Dispensing

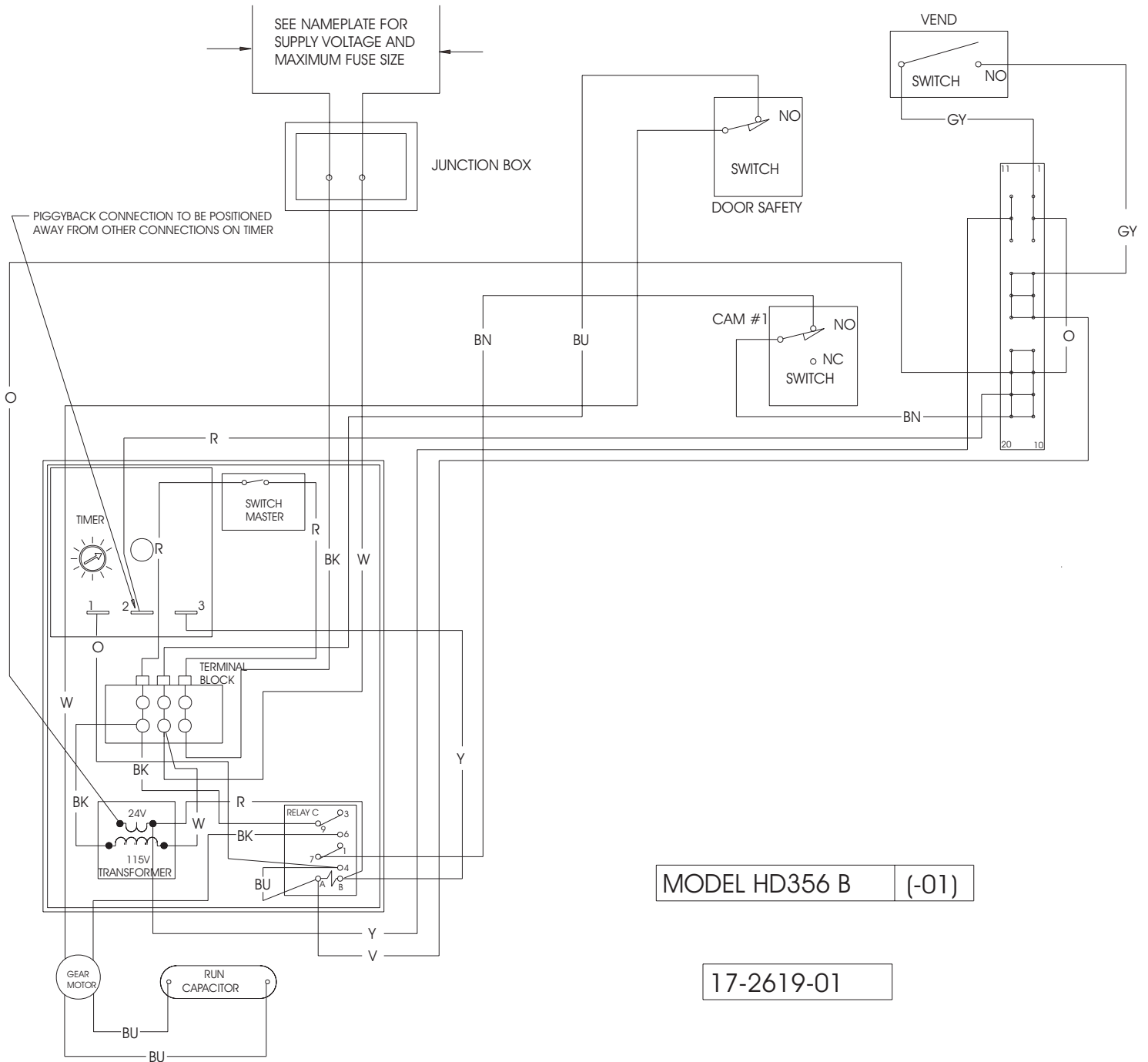

USE COPPER CONDUCTORS ONLY

THIS UNIT MUST BE GROUNDED

HD356 Service Parts

Schematic Diagram - Coin Vending

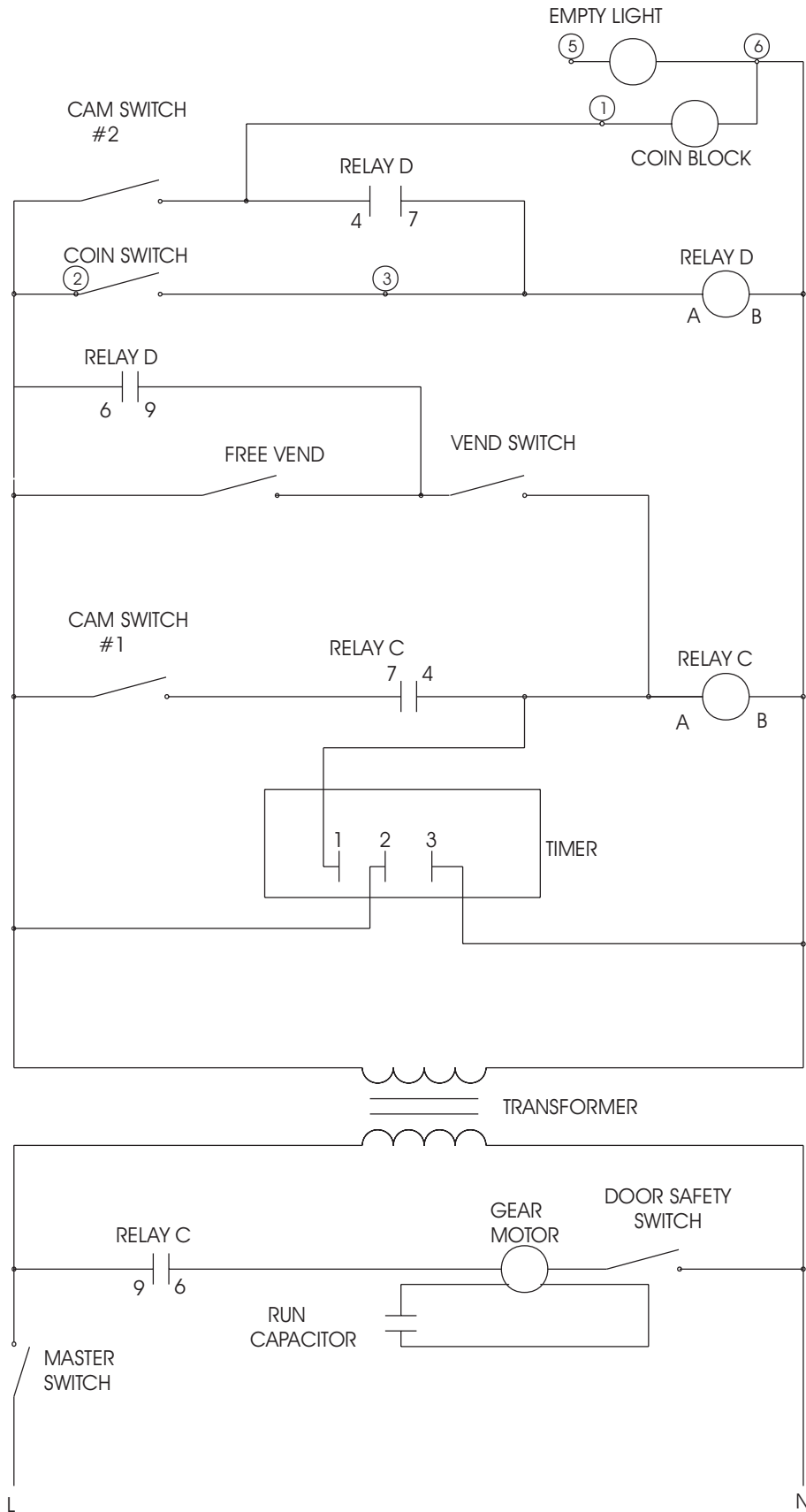

HD356 Service Parts

Schematic Diagram - Card Vending

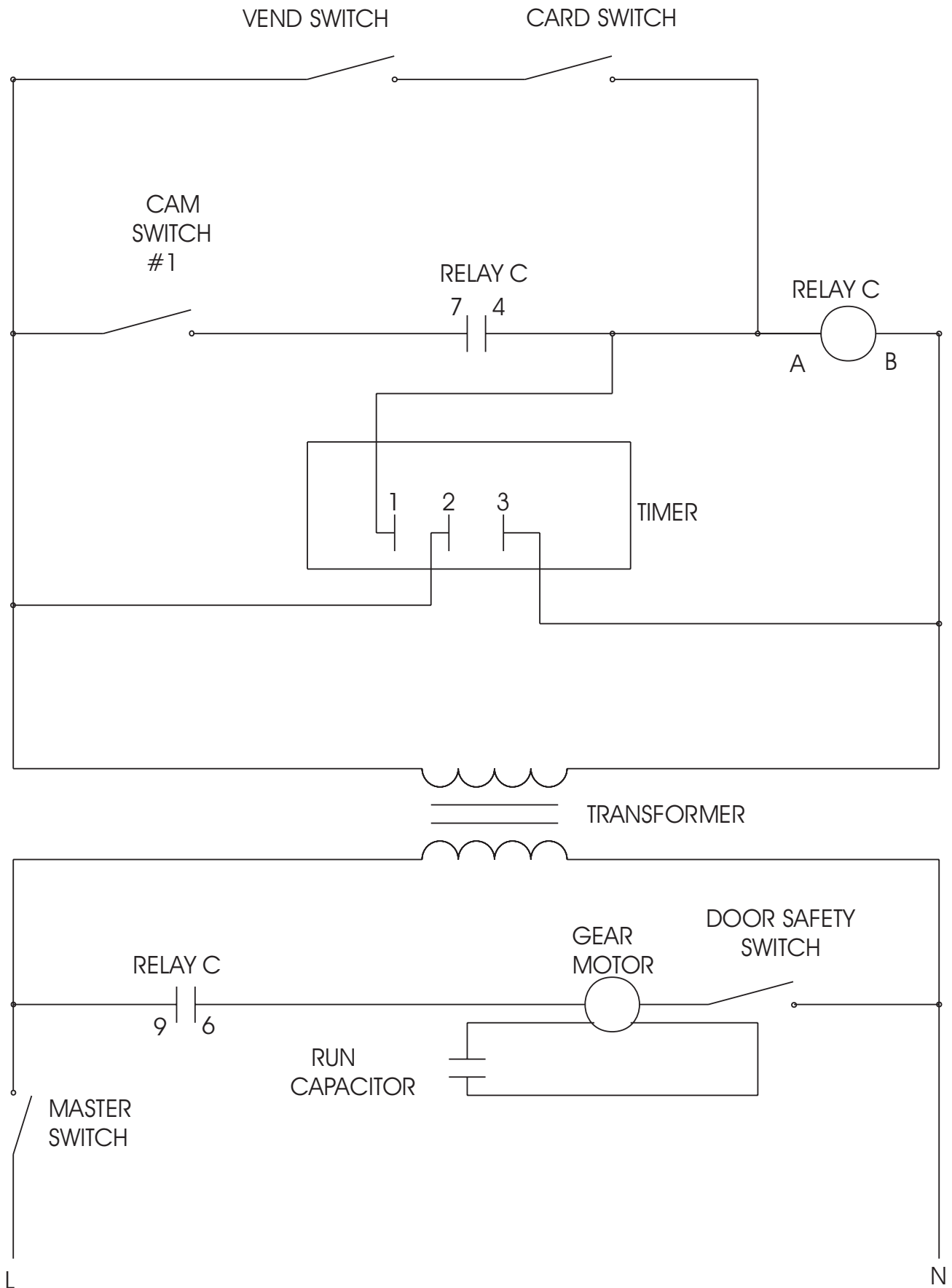

HD356 Service Parts

Wiring Diagram - Card Vending

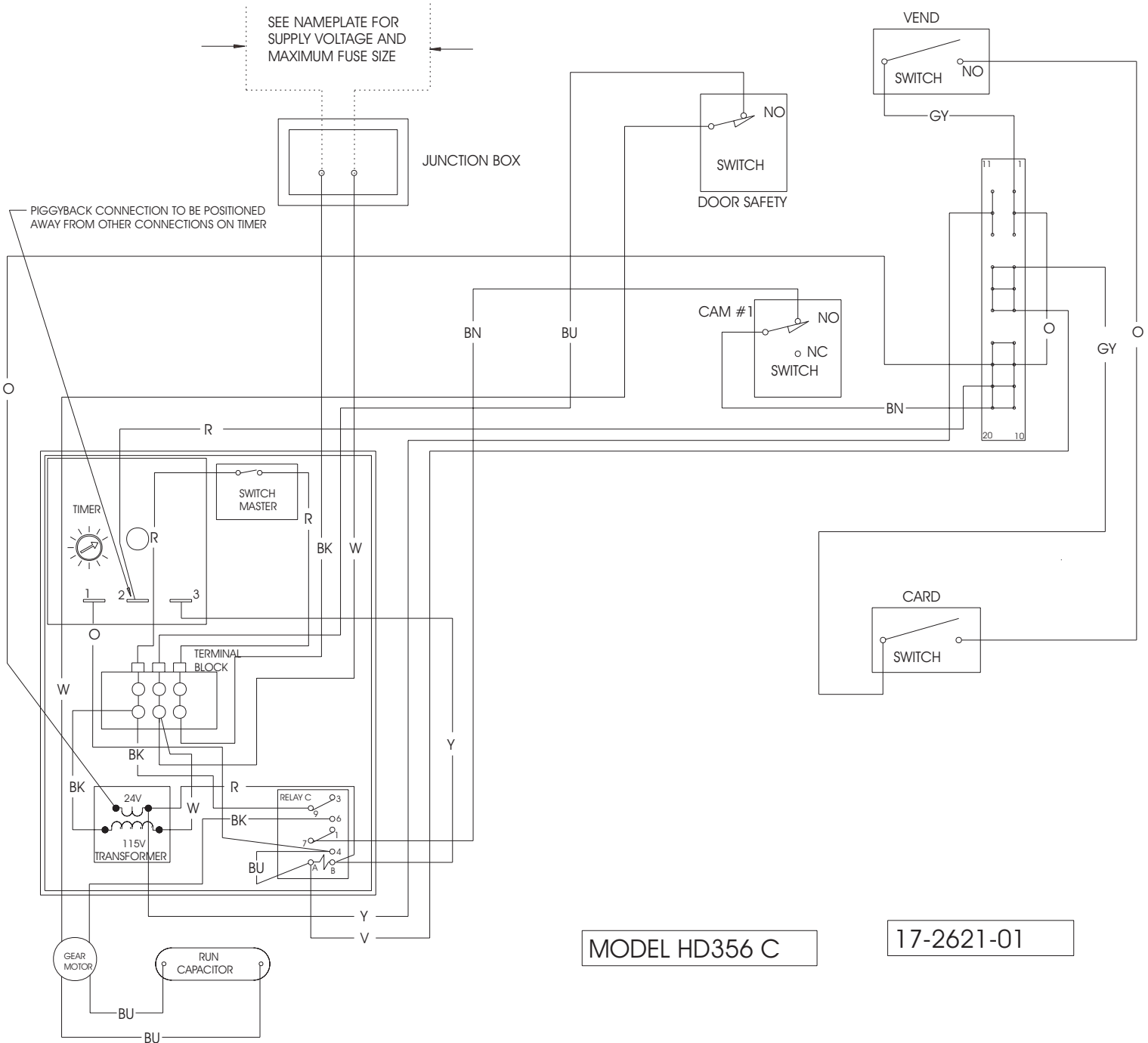

MODEL HD356 C

17-2621-01

THIS UNIT MUST BE GROUNDED

USE COPPER CONDUCTORS ONLY

HD356 Service Parts

50 Hz Wiring and Schematic Diagram

