

HD22 and HD30 Service Parts

This is the list of service parts and wiring diagrams for all versions of these two hotel dispensers.

Pay close attention to the voltage and/or cycles to be sure of ordering the correct part.

Table of Contents

Front and Top Panels	Page 2
HD30B & HD22B Front Panel	Page 3
HD30N and HD30W Front Panel & Related Parts	Page 4
Side, Back and Interior Panels	Page 5
Dispensing Components	Page 6
Ice Chute Mechanism	Page 7
Ice Catch Pan	Page 8
Control Box	Page 9
Wiring Diagram, 115 volt, 60 Hz Basic and Water Station	Page 10
Schematic Diagram, Basic and Water Station Models	Page 11
Wiring Diagram, 230 volt, 50 Hz Basic	Page 12
Wiring Diagram for Coin Mechanism Model	Page 13
Schematic Diagram for Coin Mechanism Model	Page 14

HD22 and HD30 Service Parts

Front and Top Panels

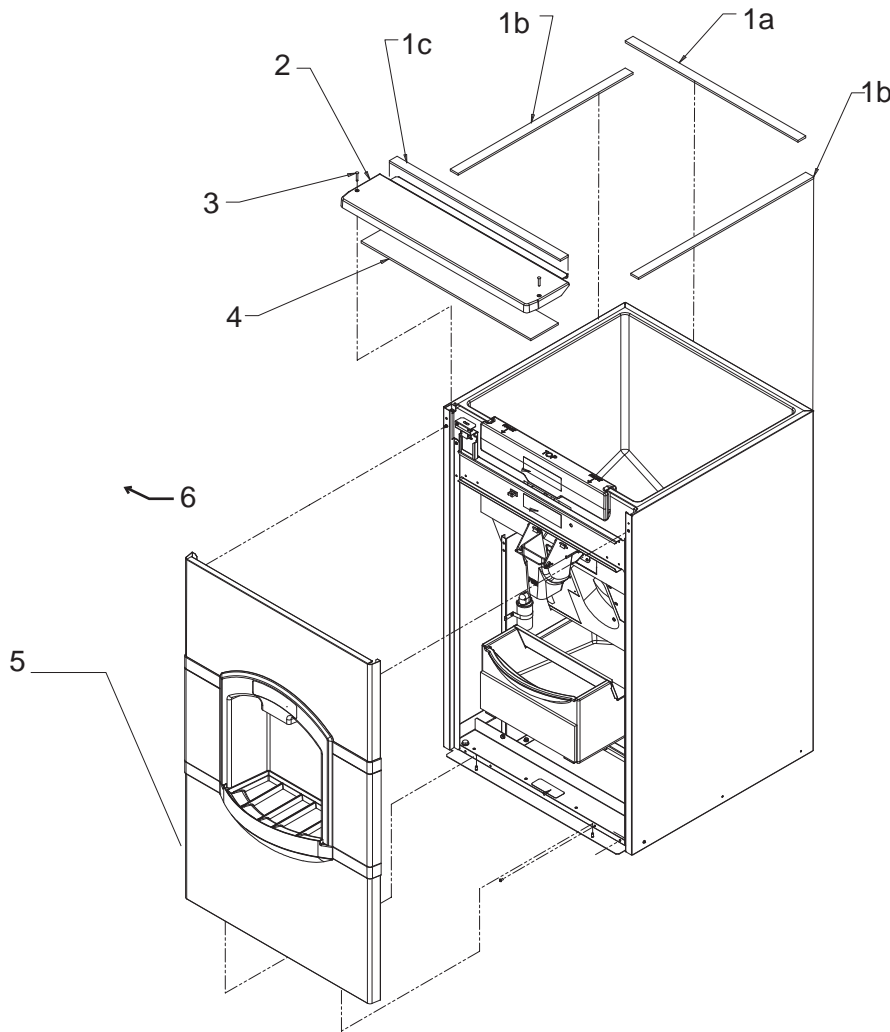

Item Number	Part Number	Description	5	
1	19-0503-04	Gasket tape, order by ft.		A38318-021 HD30B or HD30W front panel with side flanges
1a		Use 27.5" for HD30, 19.5" for HD22		A38318-023 HD30N front panel with side flanges
1b		Use 27.88"		A38319-021 HD22 front panel with side flanges
1c		Use 27.25" for HD30, 19.25" for HD22		Note: Item 5 does not include sink / drip tray components. See next page for accurate illustration.
2	02-3997-31	HD30 top panel	6a	A39516-001 HD30 Support brace, use began June 2008, fits slots in top of side panels, slots also added at that time. Kit to add to prior models: A39517-021 .
	02-3997-33	HD22 top panel		
3	03-1735-03	Top panel screw	6b	A39517-022 HD22 support brace kit
4	02-3998-01	HD30 panel insulation		
	02-3998-02	HD22 panel insulation		

HD22 and HD30 Service Parts

HD30B & HD22B Front Panel

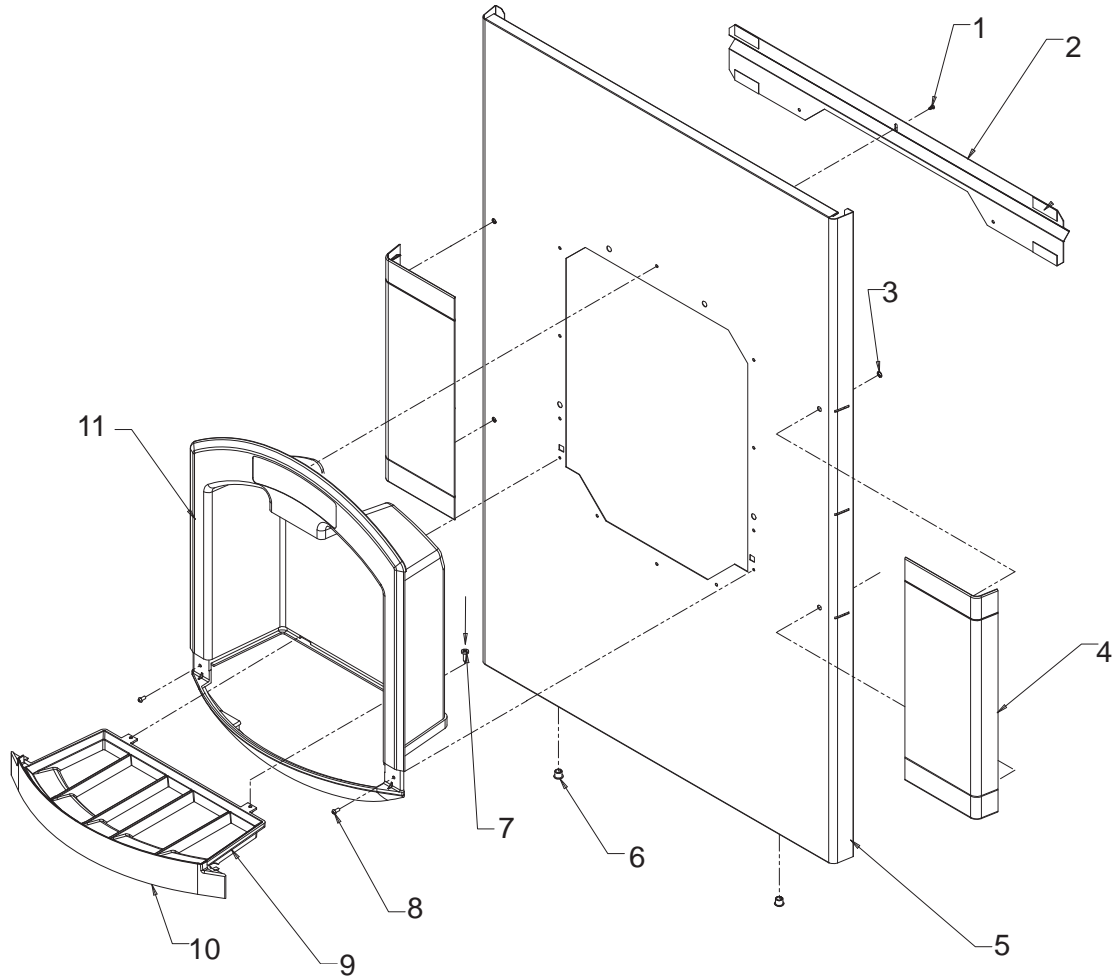

Item Number	Part Number	Description	Item Number	Part Number	Description
1	03-3836-01	Screw	11a	02-3971-31	HD22, HD30B, HD30N dispense housing
2	A38357-001	HD30 stiffener	11b	02-3971-33	HD30W dispense housing
	A38357-002	HD22 stiffener			
3	03-1731-02	Retainer			
4	02-3973-31	HD30B side flange			
	02-3973-32	HD22 side flange			
5	A38318-021	HD30 Front panel*			
	A38319-021	HD22 Front panel*			
6	12-1213-04	Snap bushing			
7	03-1404-12	Screw			
8	03-1531-01	Screw			
9	19-0503-11	Foam gasket, 6" per side			
10	02-3972-01	Grill			

* includes items 1 thru 4

HD22 and HD30 Service Parts

HD30N and HD30W Front Panel & Related Parts

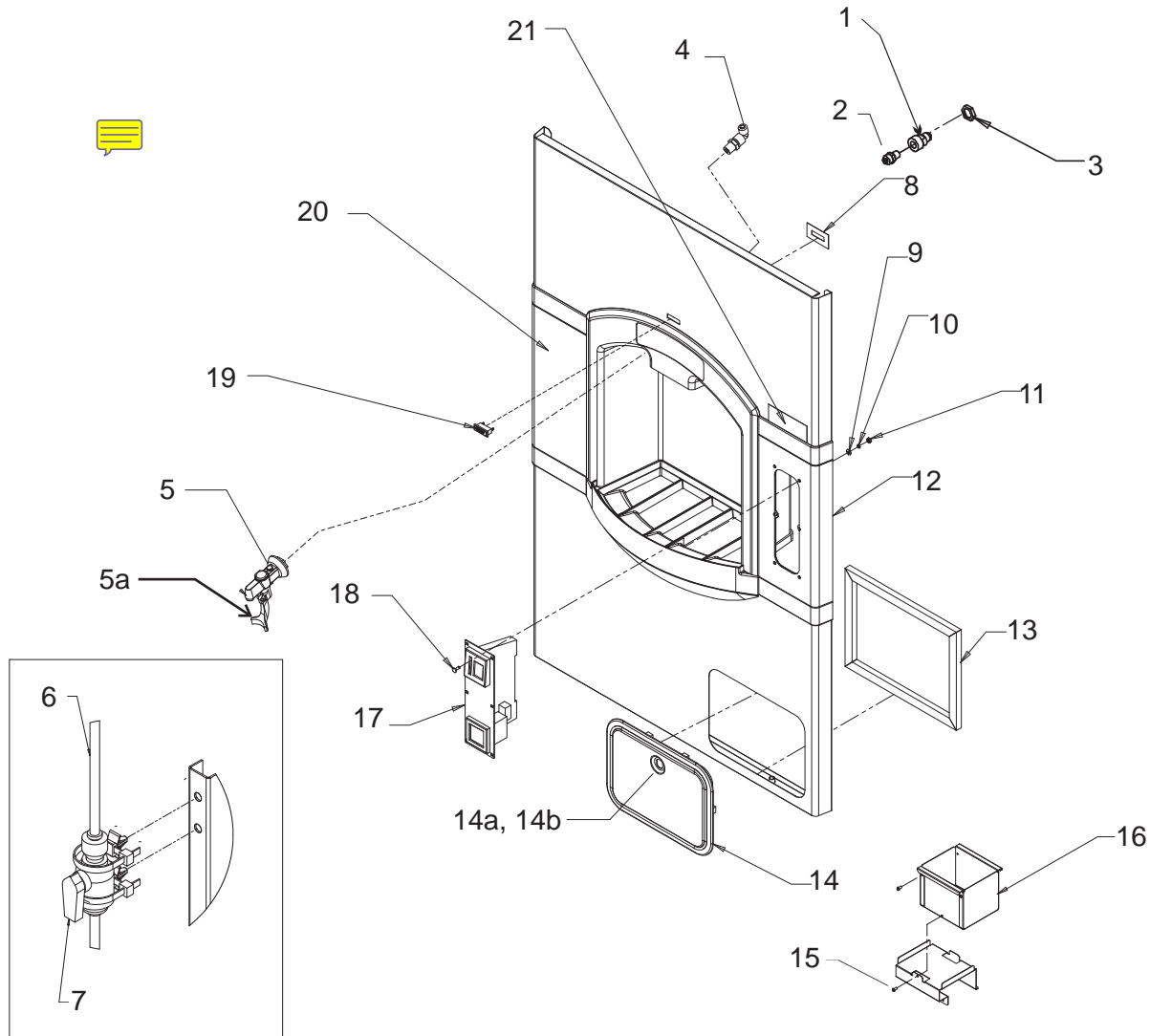

Item Number	Part Number	Description
1	16-0835-01	Water inlet fitting
2	16-1039-01	Straight connector
3	03-1394-01	Pal nut
4	16-1104-01	Male elbow connector
5	02-3990-01	Water faucet
5a	02-4754-01	Lever for faucet, clear blue
	02-4753-01	Lever for faucet, dark blue
6	13-0895-01	Tubing, order per ft
7	16-1105-01	Shut off valve
8	A38462-001	Indicator light backing
9	03-1407-02	Washer for coin mech
10	03-1410-07	Lockwasher
11	03-1406-04	Hex nut (8-32)
12	02-3973-05	Right side flange for coin mech model
13	01-1295-01	Door shim
14	12-2896-02	Door and lock
14a	12-2896-26	Lock and key
14b	12-2896-27	Key
15	03-1531-01	Coin box screw
16	A38438-001	Coin box
17	12-2896-01	Coin mechanism
	12-2896-25	Coin switch
18	12-2896-03	Mounting screw
19	12-2908-01	Ready light
20	02-3973-01	HD30 left side flange
21	17-2970-01	Coin mech label

HD22 and HD30 Service Parts

Side, Back and Interior Panels

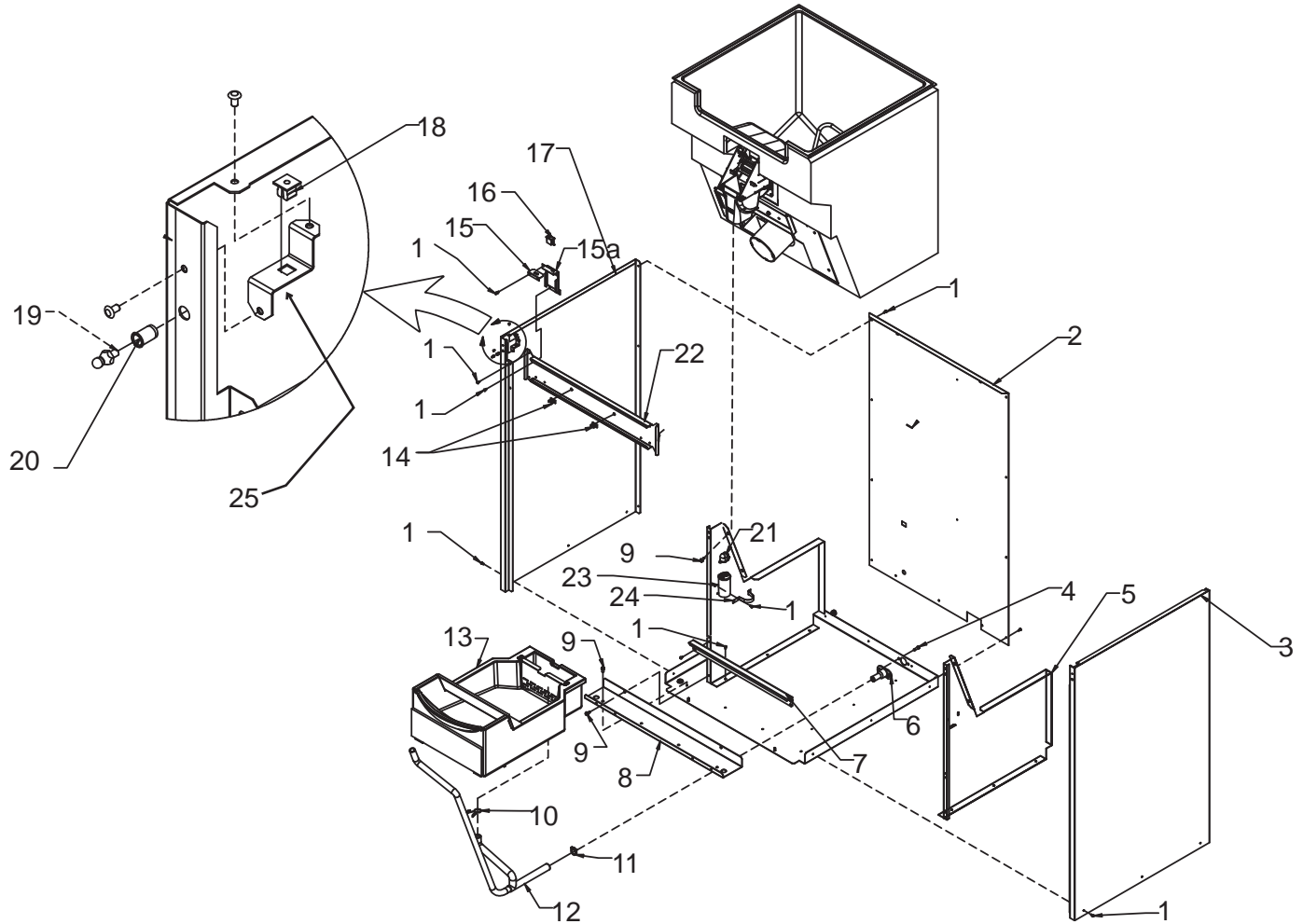

Item Number	Part Number	Description
1	03-1531-01	Screw
2	A38321-001	HD30 back panel
	A38322-001	HD22 back panel
3	A38320-022	Right side panel, includes mounting hardware
4	03-0571-01	Screw
5	A38325-002	Bin support, right
	A38325-001	Bin support, left
6	02-3692-23	Drain fitting
7	A38348-001	Catch pan support
8	A38362-001	HD30 base stiffener
	A38362-002	HD22 base stiffener
9	03-1645-01	Screw
10	02-3791-01	Hose clamp
11	02-2814-09	Hose clamp
12	02-3979-01	Drain hose
13	A38316-021	Drain pan, assembled
14	02-3011-01	Wire clamp (coin mech)
15	A38435-002	Switch plate top
15a	A38435-001	Switch plate
16	12-2961-01	Switch, interlock
17	A38320-021	Left side panel, includes mounting hardware
18	03-3804-01	Plastic nut
19	03-1733-01	Strike (ball stud)
20	03-1734-01	Insert
21	13-0666-00	Terminal cover
22	A38333-001	HD30 support bracket
	A38333-002	HD22 support bracket
23	18-1902-52	Motor capacitor
24	A35971-001	Strap
25	A38363-001	Clip

HD22 and HD30 Service Parts

Dispensing Components

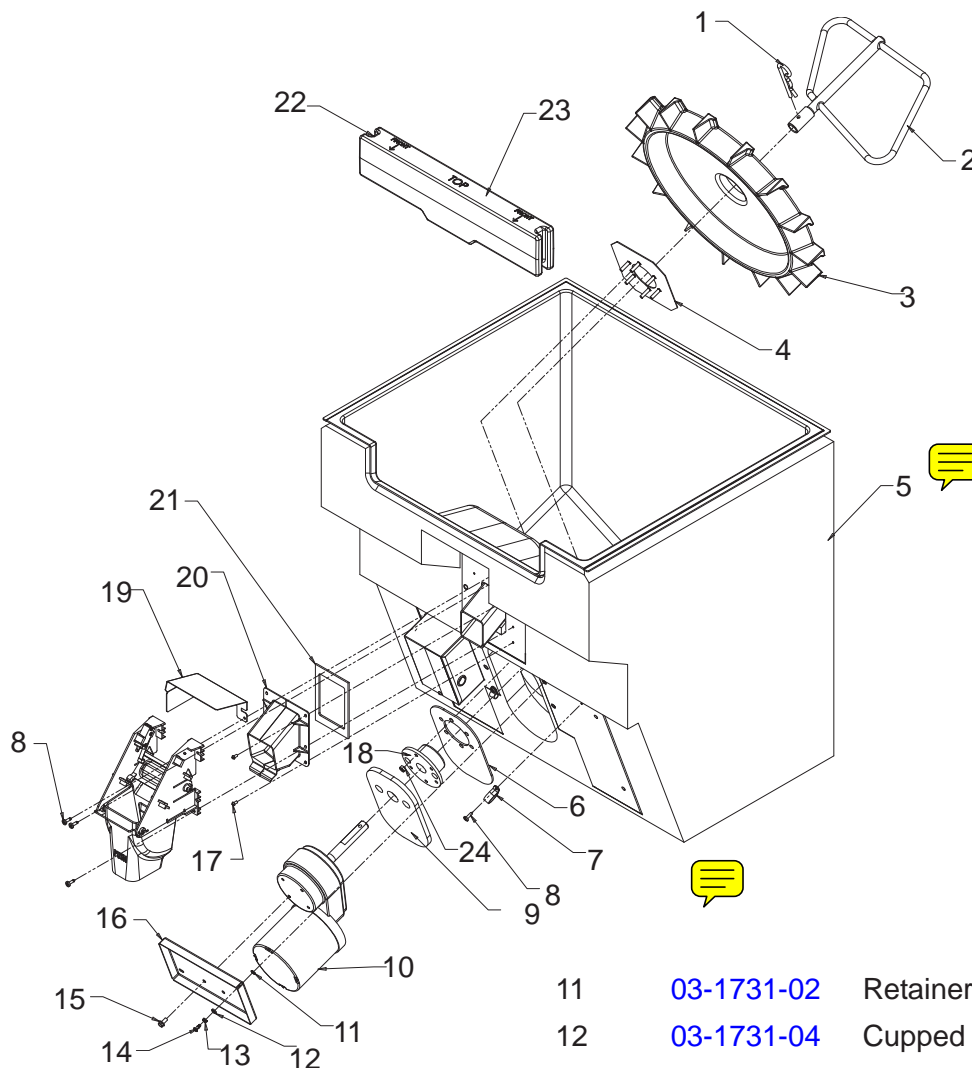

Item Number	Part Number	Description
1	03-3837-01	Hitch pin
2	02-3989-01	Sweep arm
3	02-3040-01	Dispense rotor
4	A38145-001	Hub plate
5	A38314-001	HD30 bin assembly
	A38314-002	HD22 bin assembly
6	13-0940-01	Insulation pad
7	03-3841-02	Loop clamp
8	03-1404-12	Screw
9	13-0939-01	Insulation for hub
10	12-2897-01	Dispense gearmotor, dual voltage
11	03-1731-02	Retainer
12	03-1731-04	Cupped washer
13	03-1731-03	Spring
14	03-3838-02	1/4 turn stud - for units built prior to March 23, 2012
	03-1405-13	Hex cap screw - for units built after March 23, 2012
15	03-1645-01	Screw
16	A38342-001	Mounting plate
17	03-1531-01	Screw
18	A34760-001	Hub
19	A38446-001	Switch guard
20	02-3965-01	Spout
21	02-4000-01	Gasket
22	19-0503-09	Gasket, 4" each end
23	A38341-002	Bin door
24	03-1406-08	Nut

HD22 and HD30 Service Parts

Ice Chute Mechanism

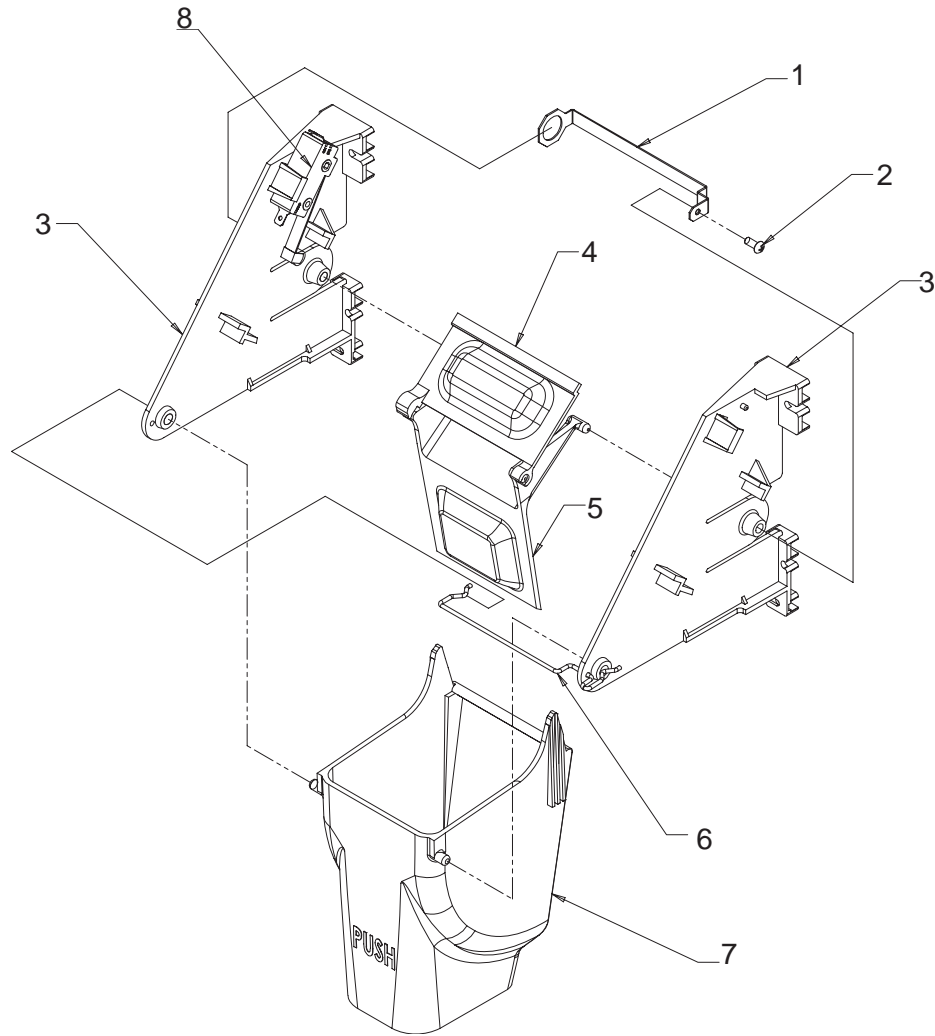

Item Number	Part Number	Description
1	A38455-001	Clip
2	03-1531-01	Screw
3	02-3964-01	Bracket
4	02-3963-01	Door lock
5	02-3962-01	Door
6	02-3970-01	Wire
7	02-3961-01	Dispense chute
8	12-2879-01	Vend switch, 60 Hz
	12-2958-01	Vend switch, 50 Hz, CE only

HD22 and HD30 Service Parts

Ice Catch Pan

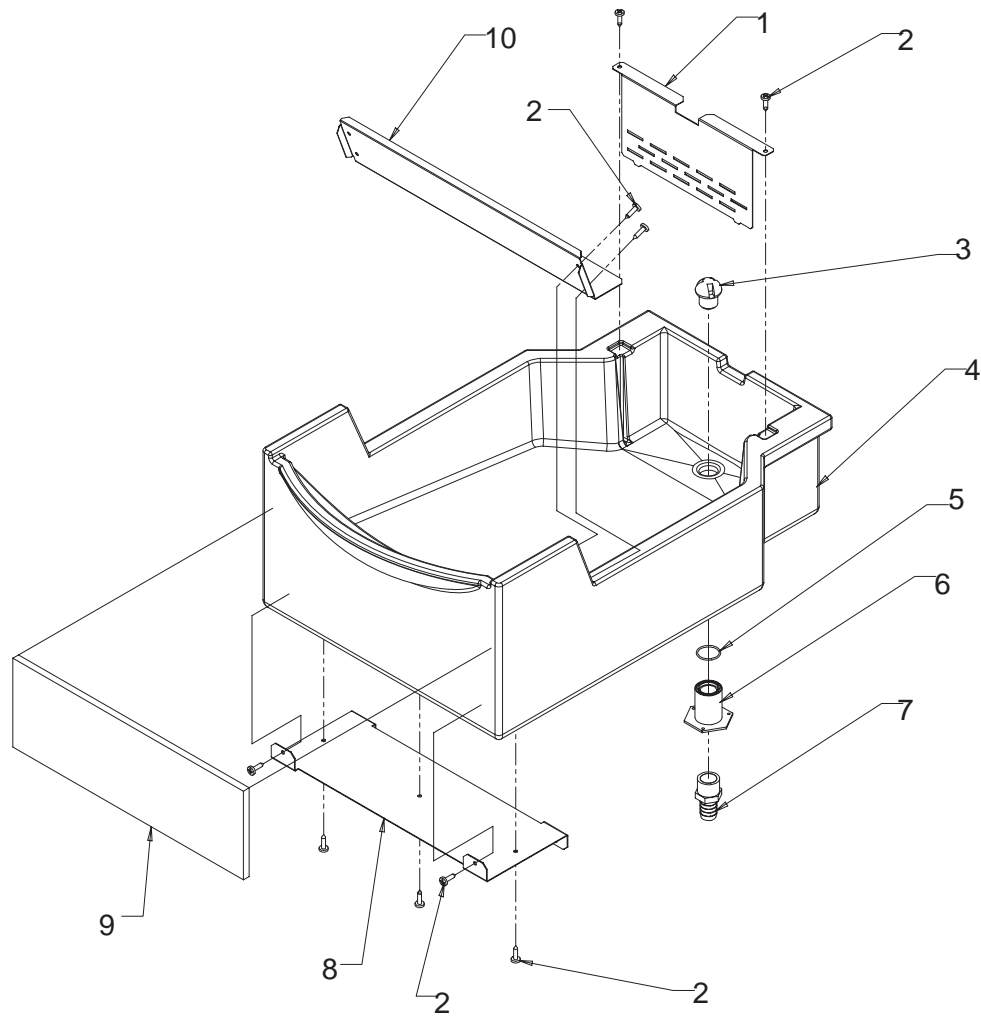

Item Number	Part Number	Description
1	A38332-001	Screen
2	03-1404-12	Screw
3	02-2809-02	Drain top
4	A38316-021	Complete assembly as shown
5	02-4193-01	Flat washer
6	02-3201-01	Drain bottom
7	16-1099-01	Drain fitting
8	A38454-001	Drain pan bracket
9	02-3999-01	Foam pad
10	A38447-001	Drain guard

HD22 and HD30 Service Parts

Control Box

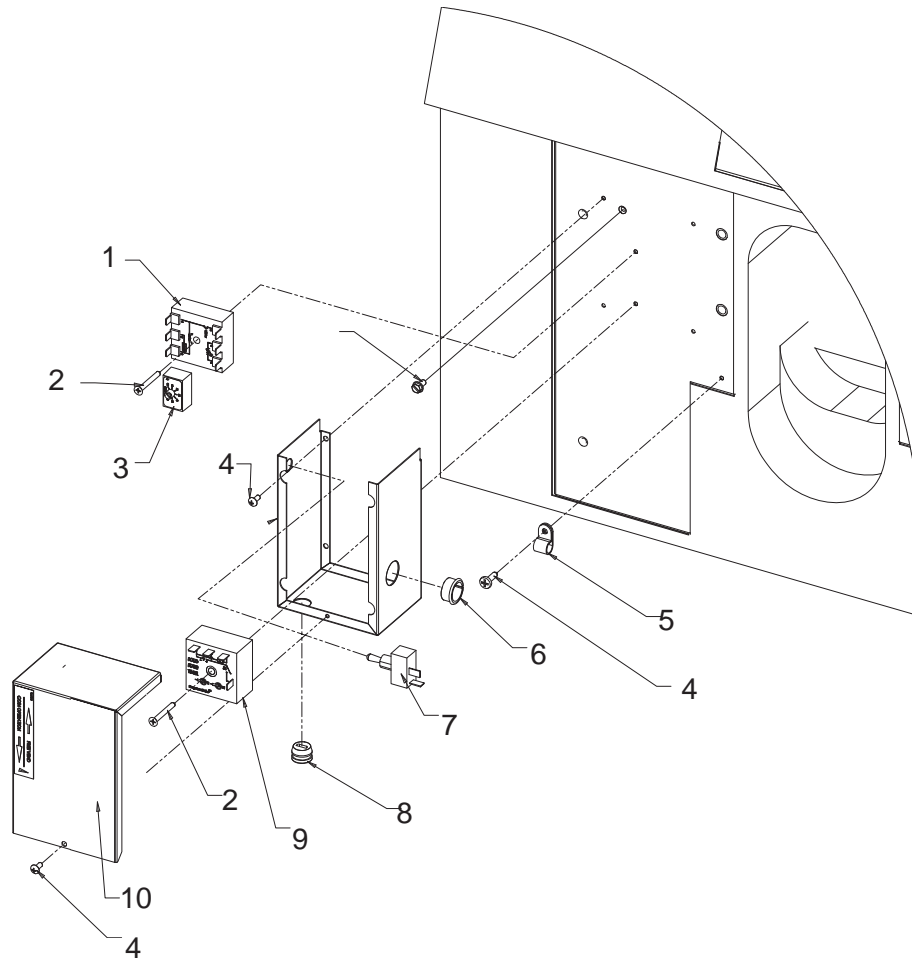

Item Number	Part Number	Description	Not shown
1	12-2948-21	Coin mech timer*	11 12-2880-01 60 Hz harness, basic and water
2	03-1419-16	Screw	12-2891-01 Coin mech harness
3	part of item 1		12-2904-01 50 Hz harness
4	03-1531-01	Screw	12 12-1638-20 115 volt power cord
5	03-3841-01	Loop clamp	12-1638-18 230 volt power cord
6	12-1213-10	Snap bushing	
7	12-2637-01	Free vend switch	
8	12-0629-08	Strain relief	
9	12-2881-01	60 Hz off cycle timer	
	12-2881-02	50 Hz off cycle timer	
10	A38330-001	Control box cover	

* Note: Use of this timer includes a wiring change. Prior timers had separate adjustment modules and used the wiring diagram on page 13. Refer to page 15 for wiring of this timer.

HD22 and HD30 Service Parts

Wiring Diagram, 115 volt, 60 Hz Basic and Water Station

17-2956-01

ALL CONTROLS SHOWN IN
NORMAL ICE DISPENSING MODE

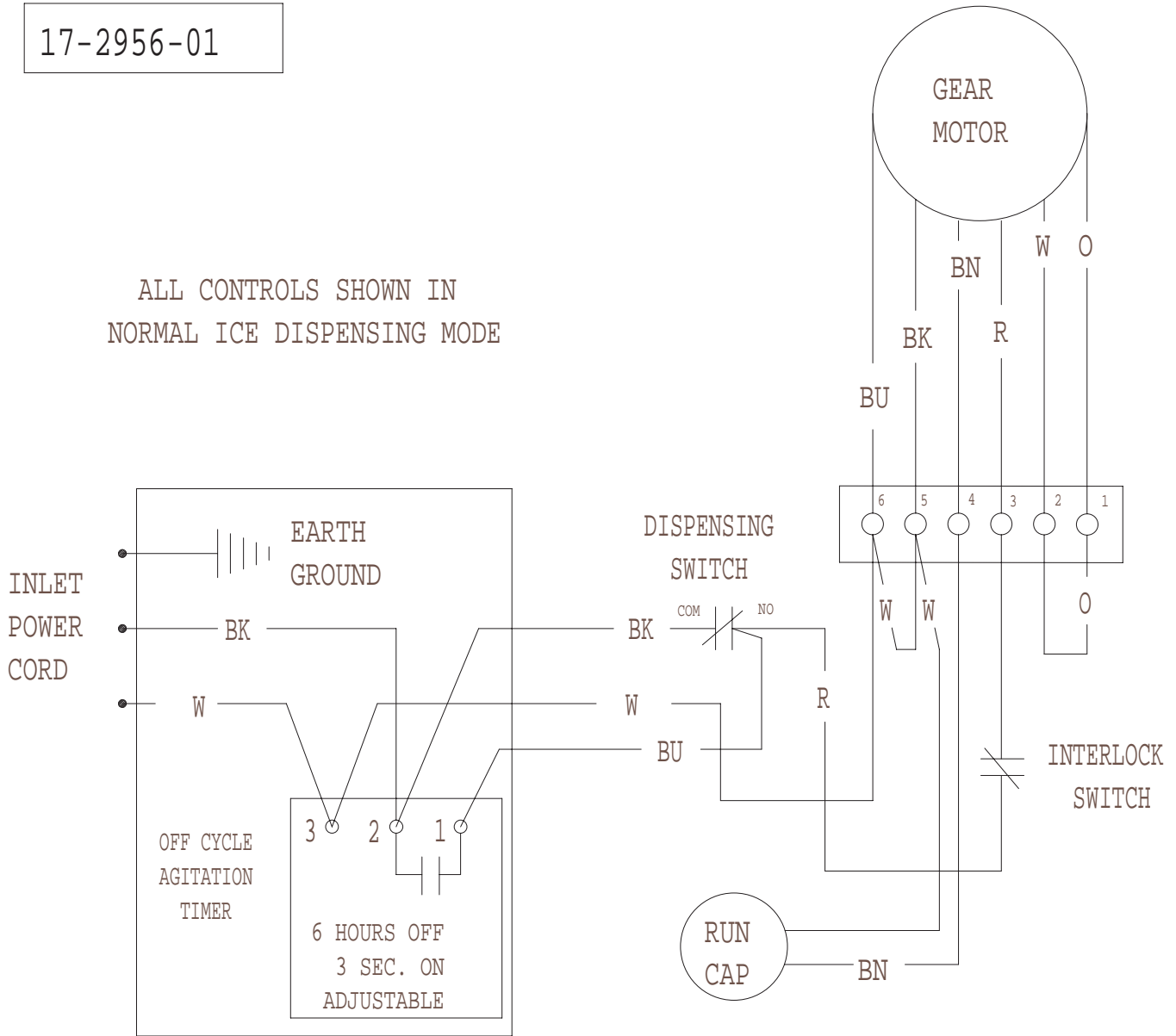

USE COPPER CONDUCTORS ONLY

HD22 and HD30 Service Parts

Schematic Diagram, Basic and Water Station Models

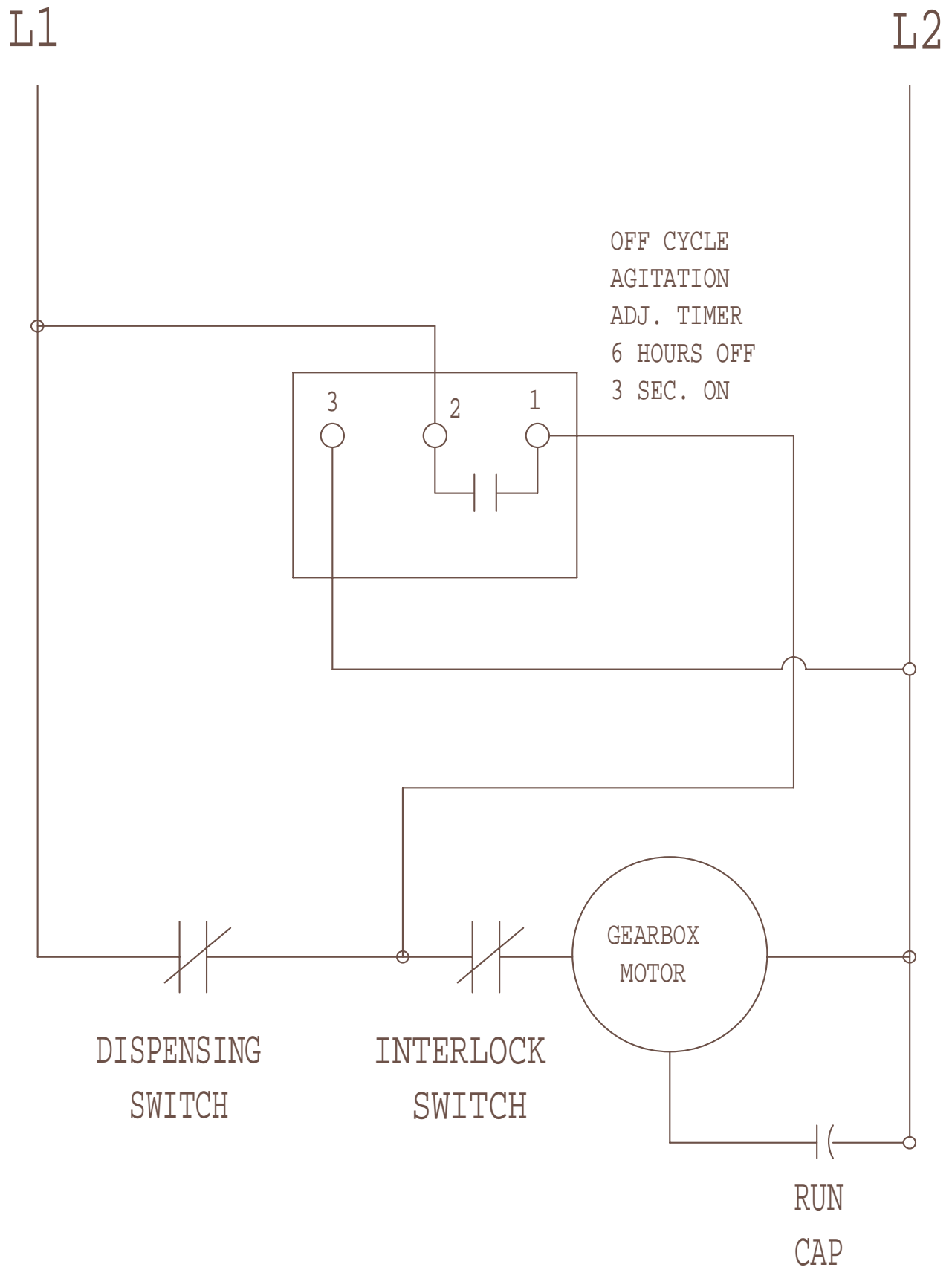

HD22 and HD30 Service Parts

Wiring Diagram, 230 volt, 50 Hz Basic

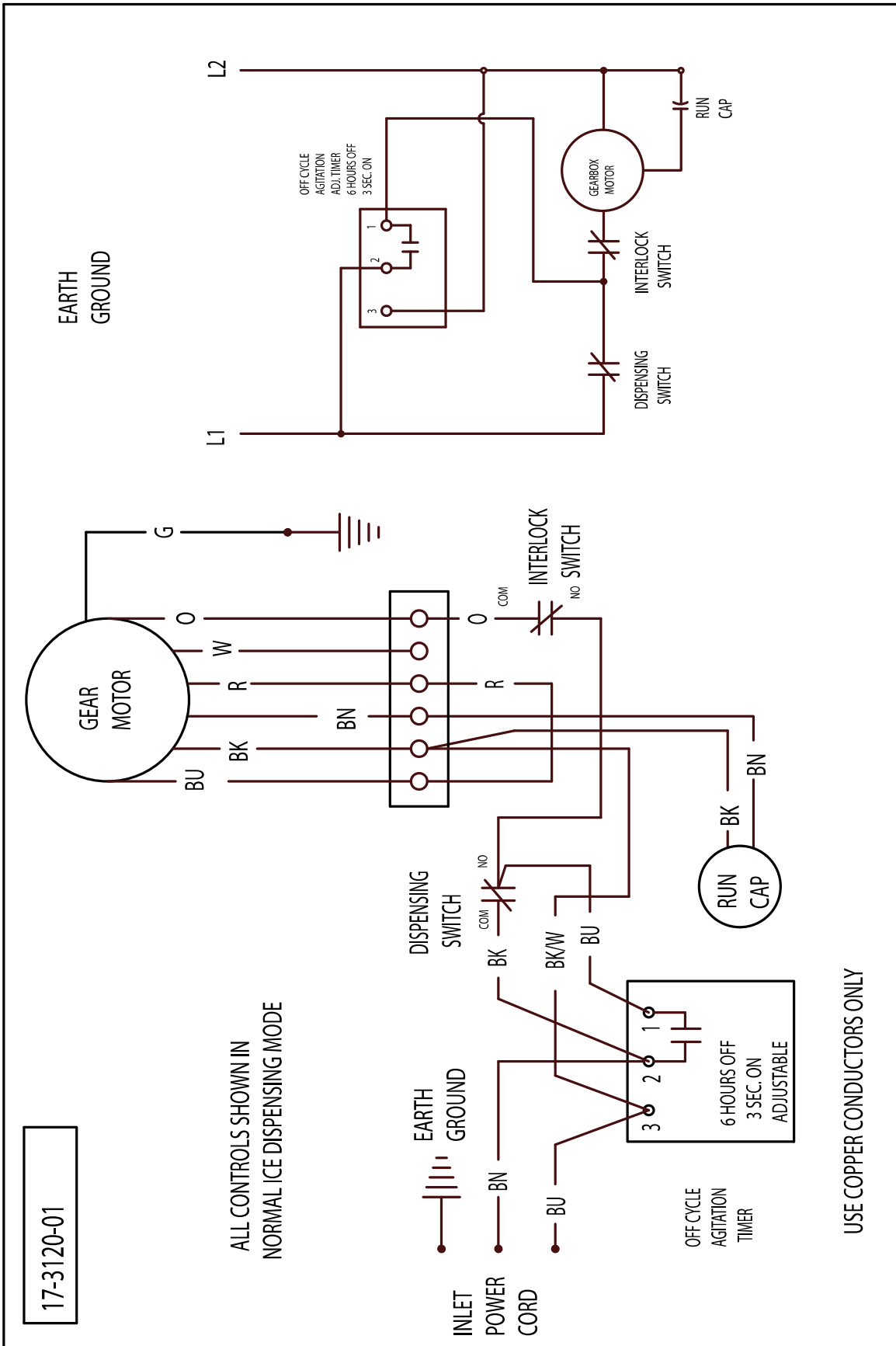

HD22 and HD30 Service Parts

Wiring Diagram for Coin Mechanism Model, with prior coin mech timer

17-2967-01

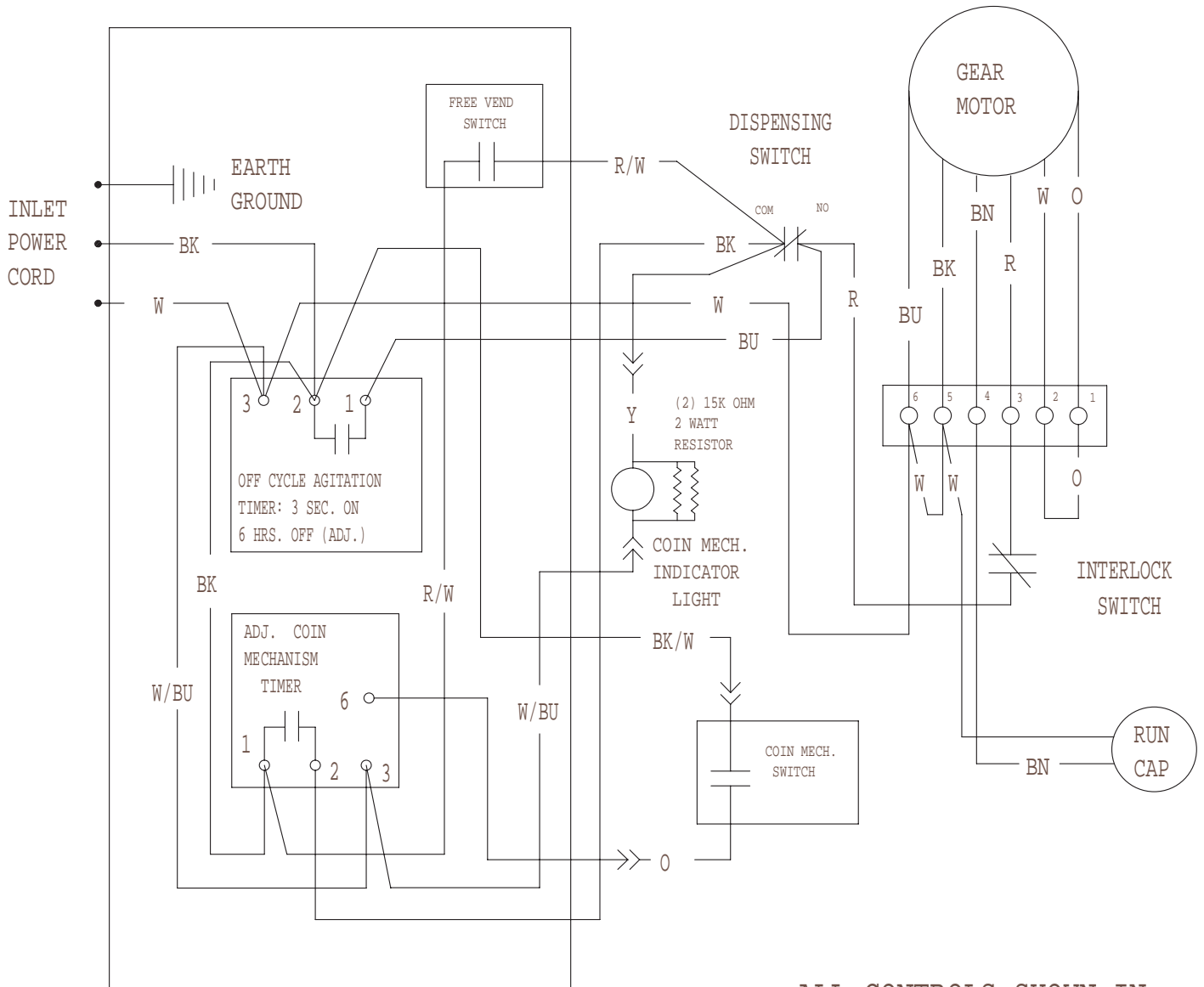

USE COPPER CONDUCTORS ONLY

ALL CONTROLS SHOWN IN
NORMAL ICE DISPENSING MODE

HD22 and HD30 Service Parts

Schematic Diagram for Coin Mechanism Model

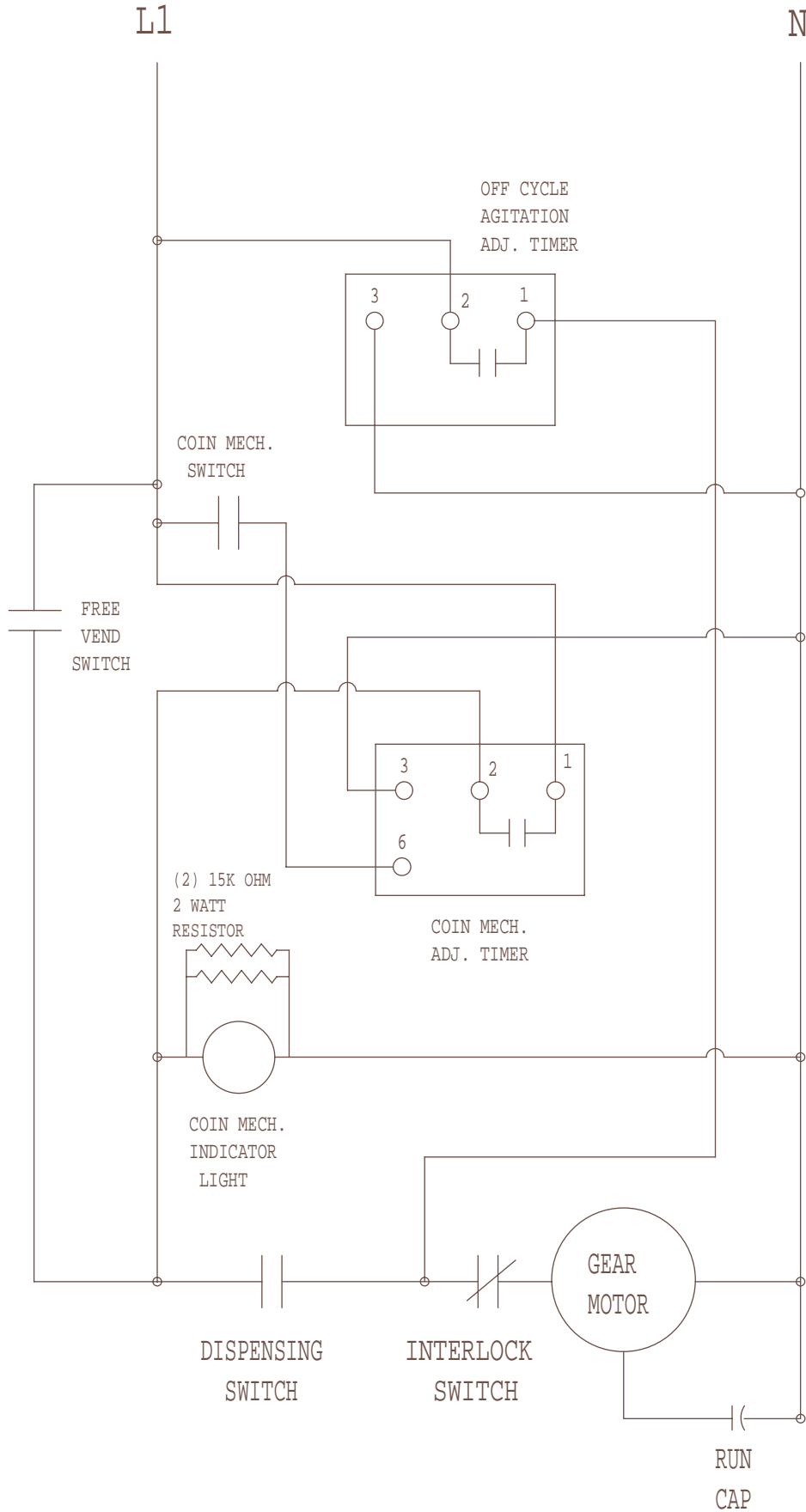

HD22 and HD30 Service Parts

Wiring Diagram for Coin Mechanism Model after 2006 coin mech timer change

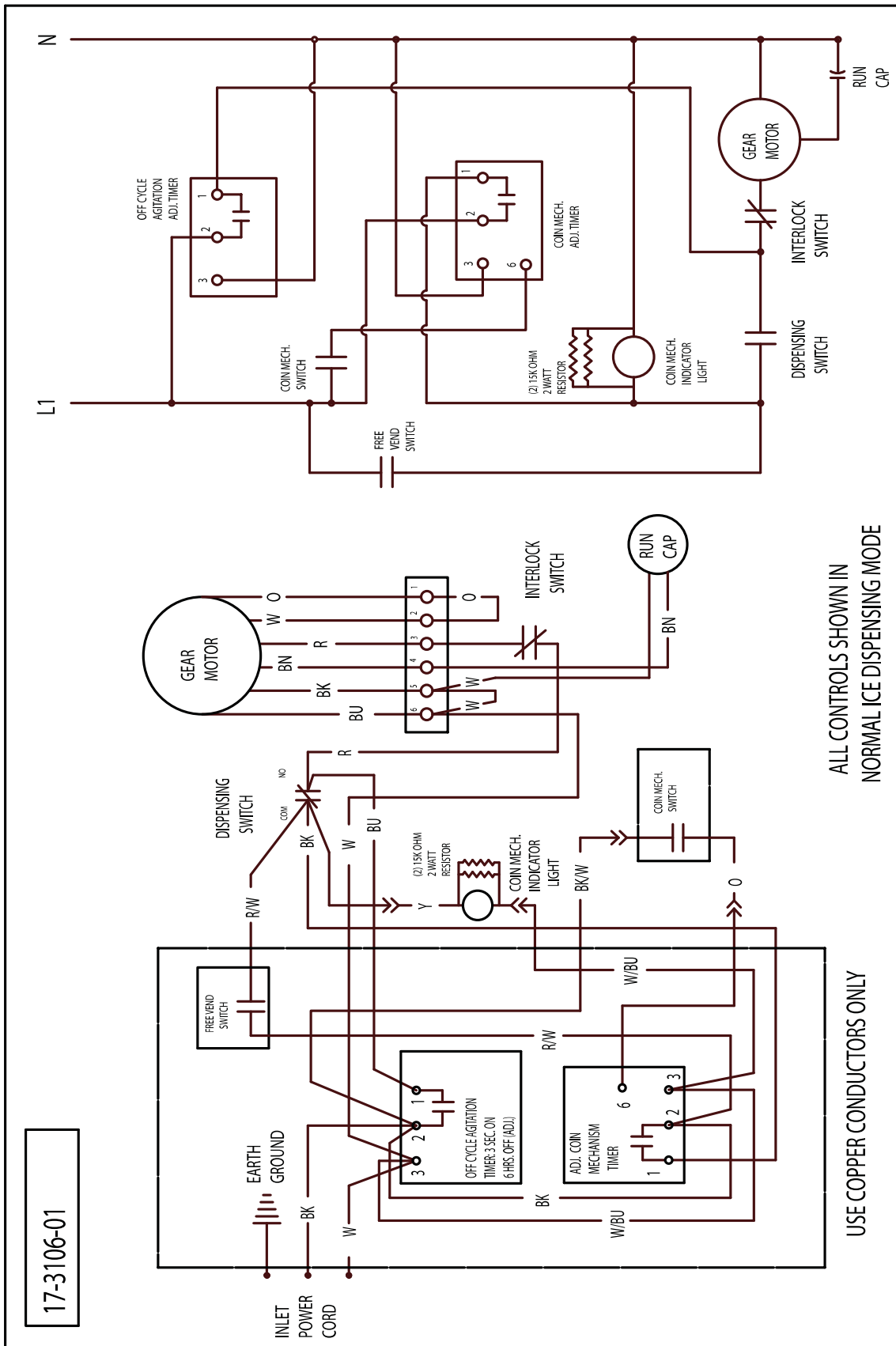



Bulletin Number: PS - 4 - 2006

Bulletin Date: April 2006

SERVICE BULLETIN

Subject: HD30 Coin Mech Timer Change

The timer used by the HD30 coin vending model to time out the vend has been changed. It was a two part timer, but now is a single piece.

The change began with units produced 12/15/2005.

The prior timer parts are obsolete and no longer available. The new timer can be used in place of the old one by switching the position of the two wires on terminals 1 and 2. Refer to the tables below.

The new timer is part number [12-2948-21](#)

Wire Connections to Prior Timer	
Wire Color	Terminal Numbers
BK and R/W	1
BK	2
W/BU	3
O	6

Wire Connections to Current Timer	
Wire Color	Terminal Numbers
BK	1
BK and R/W	2
W/BU	3
O	6