

NME1854 & FME2404 SERVICE PARTS

This parts list contains the service parts and wiring diagrams for this model.
Water cooled condensers changed between the A and B series.
Check the model number in question to be sure that it is applicable to this parts list.
The compressor changed in 2012 from an RS type to an RST type.

Table of Contents

Cabinet Assembly	Page 2
Air Cooled Refrigeration	Page 3
Water Cooled Refrigeration	Page 4
Water System	Page 5
Gearmotor	Page 6
NME Evaporator	Page 7
FME Evaporator	Page 8
Control Box	Page 9
Compressors and Starting Components	Page 10
230/50/1	Page 15

NME1854 & FME2404 SERVICE PARTS

Cabinet Assembly

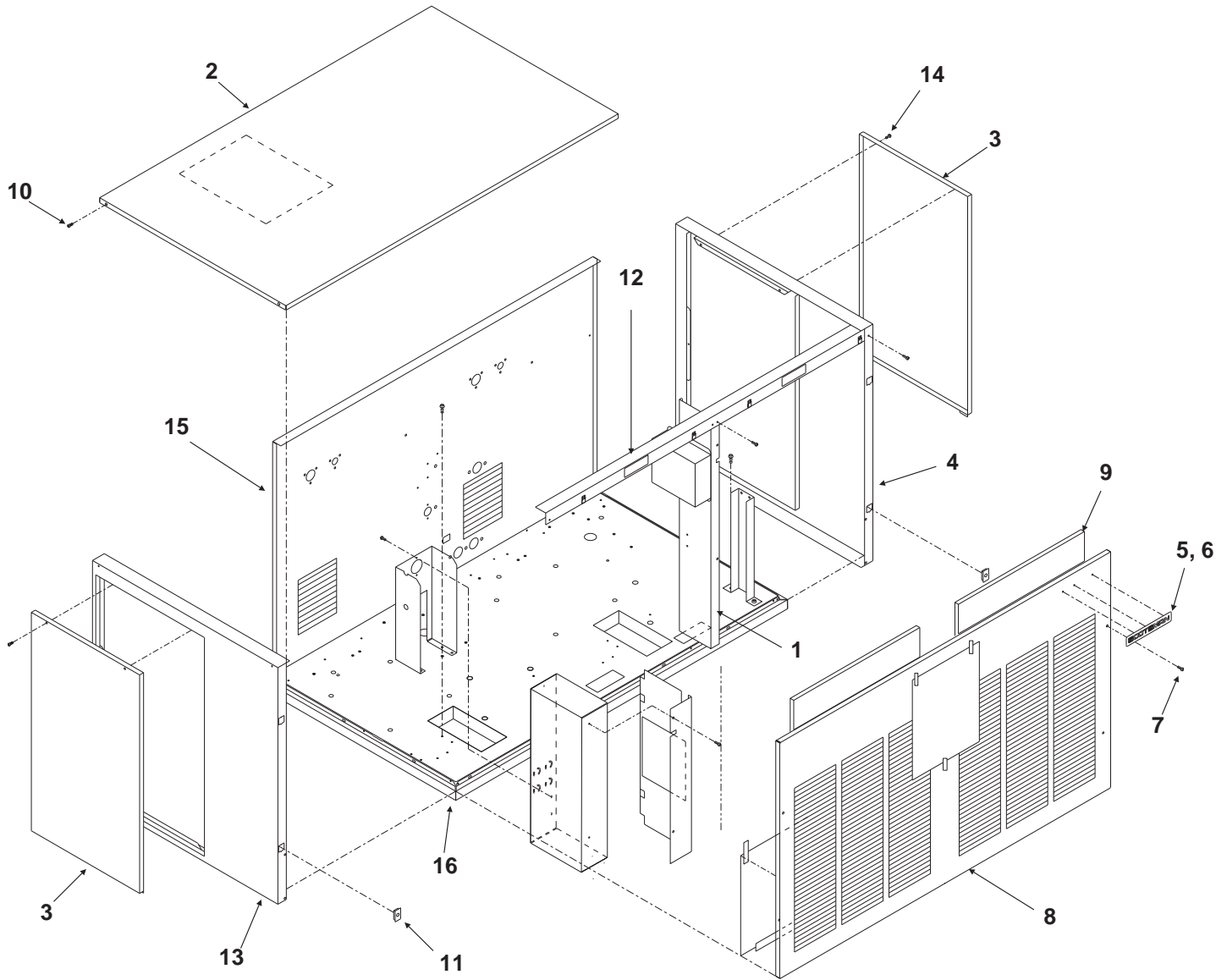

ITEM NUMBER	PART NUMBER	DESCRIPTION	ITEM NUMBER	PART NUMBER	DESCRIPTION
1	A34286-001	Center Support	8	A34294-002	Front Panel, S.S.
2	A32461-002	Top Panel, S.S.	9	02-2976-01	Air filter
3	A34038-002	Service Panel, S.S.		03-1660-01	Clip for filter
4	A33292-002	Right Side Panel, S.S.	10	03-1531-01	Screw
5	03-0271-00	Speed Clip	11	02-0836-00	Catch
6	15-0808-01	Emblem	12	A34287-015	Support
7	03-1419-22	Screw	13	A32435-002	Left Side Panel, S.S.
			14	03-1404-12	Screw
			15	A36517-002	Back panel (WC)
			16.	A36554-001	Base

NME1854 & FME2404 SERVICE PARTS

Air Cooled Refrigeration

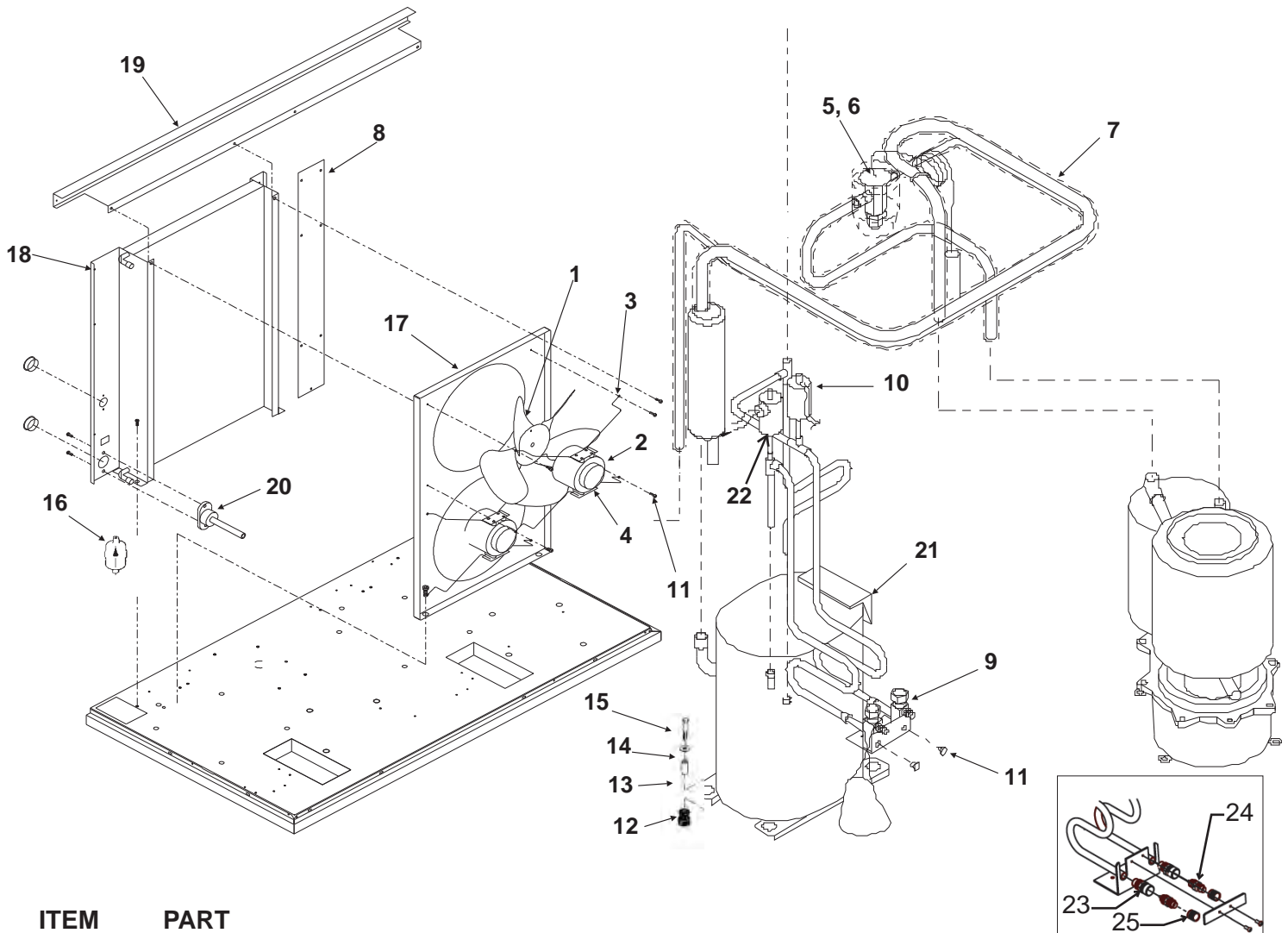

Alt. Access Valve

ITEM NUMBER	PART NUMBER	DESCRIPTION
1	18-3815-01	Fan Blade
2	12-1576-02	Fan Motor
3	02-2378-01	Fan Bracket
4	03-1531-01	Screw
5	A32961-020	Insulation Kit (3 piece)
6	11-0488-21	Thermo Expansion Valve
7	A36496-001	Suction Line
8	A34285-001	Filler panel
9	16-0832-20	Access valve
9a	16-0832-02	Stem cap
9b	16-0832-03	Core cap
10	11-0501-22	Hi Pressure Cut Out
11	03-1645-01	Screw
12	18-2200-28	Grommet
13	18-2200-27	Sleeve
14	03-1407-07	Washer
15	03-1405-20	Cap Screw
16	02-3319-02	Dryer
17	A33231-001	Fan Shroud

ITEM NUMBER	PART NUMBER	DESCRIPTION
18	18-8717-01	Condenser
19	A35613-015	Condenser Support
20	02-3692-22	Drain fitting
21	See page 10	Compressor
22	11-0502-21	Low pressure cut out
23	16-1137-01	Access valve body
24	16-1139-01	Core
25	16-1140-01	Cap

NME1854 & FME2404 SERVICE PARTS

Water Cooled Refrigeration

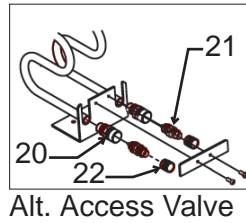
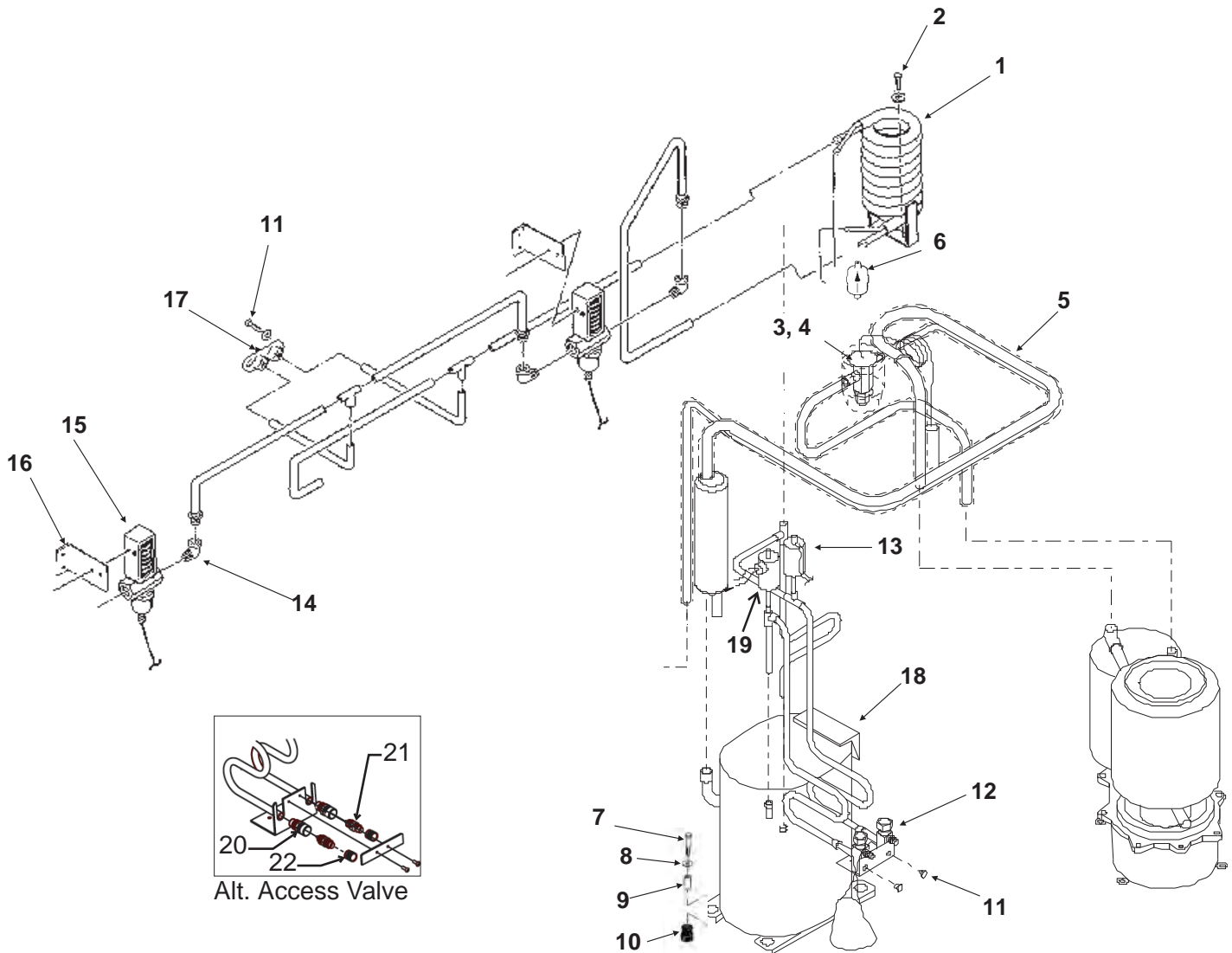

ITEM NUMBER	PART NUMBER	DESCRIPTION	ITEM NUMBER	PART NUMBER	DESCRIPTION
1	18-8718-25 18-8873-21	A series WC condenser B series WC condenser	13	11-0501-22	Hi Pressure Cut Out
2	03-1645-01	Screw	14	16-0401-02	Elbow
3	11-0488-21	Thermo Expansion Valve	15	11-0608-21	Water Reg. Valve
4	19-0599-06	Insulation Kit (3 piece)	16	A34341-001	Bracket
5	A36496-001	Suction Line	17	A32282-004	Drain Assembly
6	02-3319-02	Dryer	18	see page 10	Compressor
7	03-1405-20	Cap Screw	19	11-0502-21	Low pressure cut out
8	03-1407-07	Washer	20	16-1137-01	Access valve body
9	18-2300-27	Sleeve	22	16-1139-01	Core
10	18-2200-28	Grommet	25	16-1140-01	Cap
11	03-1645-01	Screw			
12	16-0832-20	Access valve			
12a	16-0832-02	Stem cap			
12b	16-0832-03	Core cap			

NME1854 & FME2404 SERVICE PARTS

Water System

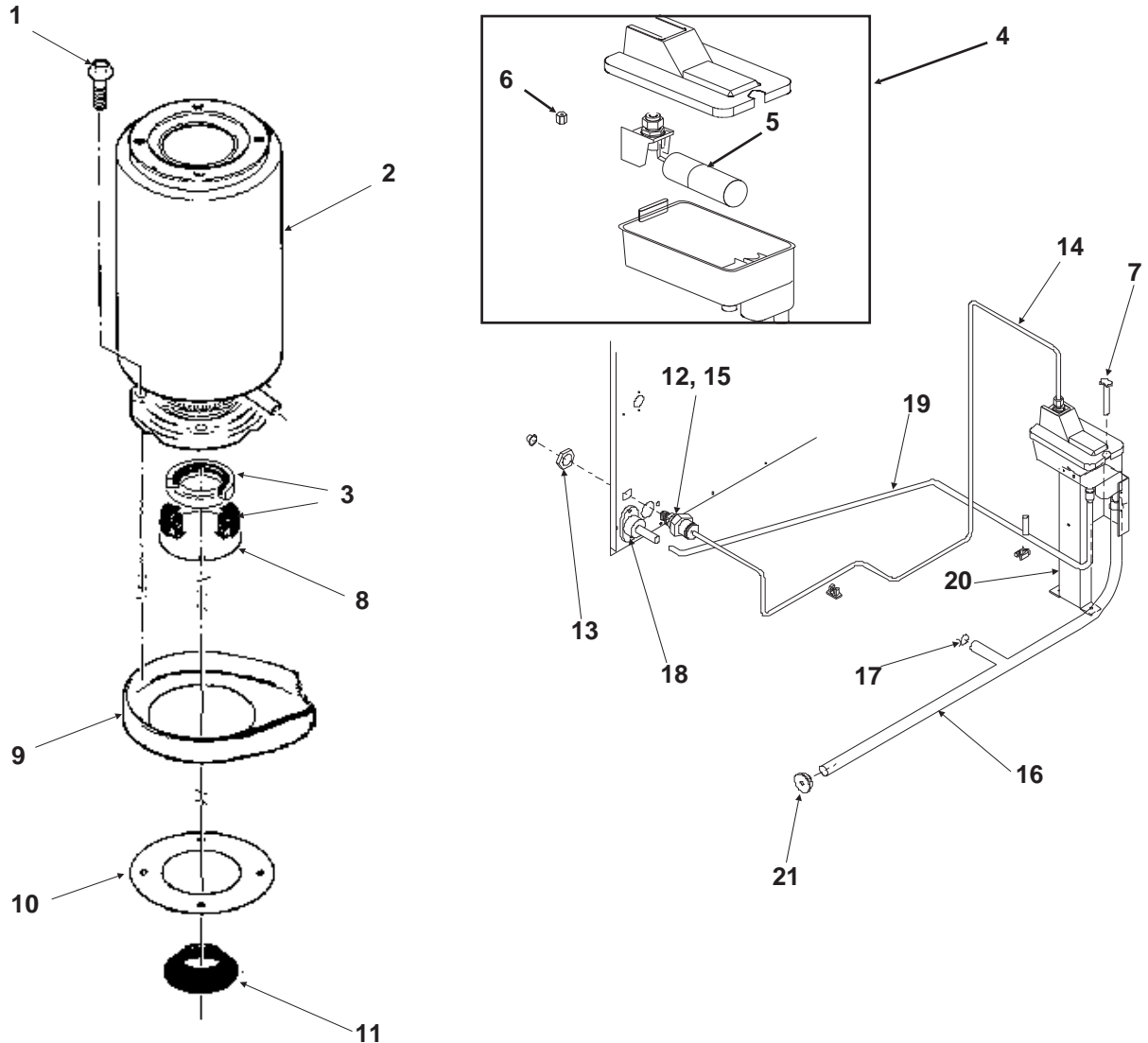

ITEM NUMBER	PART NUMBER	DESCRIPTION	ITEM NUMBER	PART NUMBER	DESCRIPTION
1	03-1405-41	Cap Screw	15	16-1039-01	Male connector
2	A32890-020	Evaporator	16	A36154-001	Evap. water inlet tube
3	02-0929-23	Water Seal	17	02-1338-00	Hose clamp
4	02-3266-01	Reservoir & valve	18	02-3692-22	Drain fitting
5	02-3266-02	Float valve	19	02-3826-01	Res. overflow hose (right)
6	02-3266-03	Plunger/seal		02-3826-02	Res. overflow hose (left)
7	12-2760-21	Water Level Sensor	20	A37482-001	Reservoir bracket
8	A32777-001	Retaining Ring for Seal	21	13-0840-01	Rubber cap
9	02-3837-01	Drip Pan			
10	13-0704-00	Gasket			
11	02-4663-01	Water Shed			
12	16-0835-01	Inlet fitting for plastic tubing			
13	03-1394-01	Pal Nut			
14	13-0895-01	Inlet tubing, 4 ft. req.			

NME1854 & FME2404 SERVICE PARTS

Gearmotor

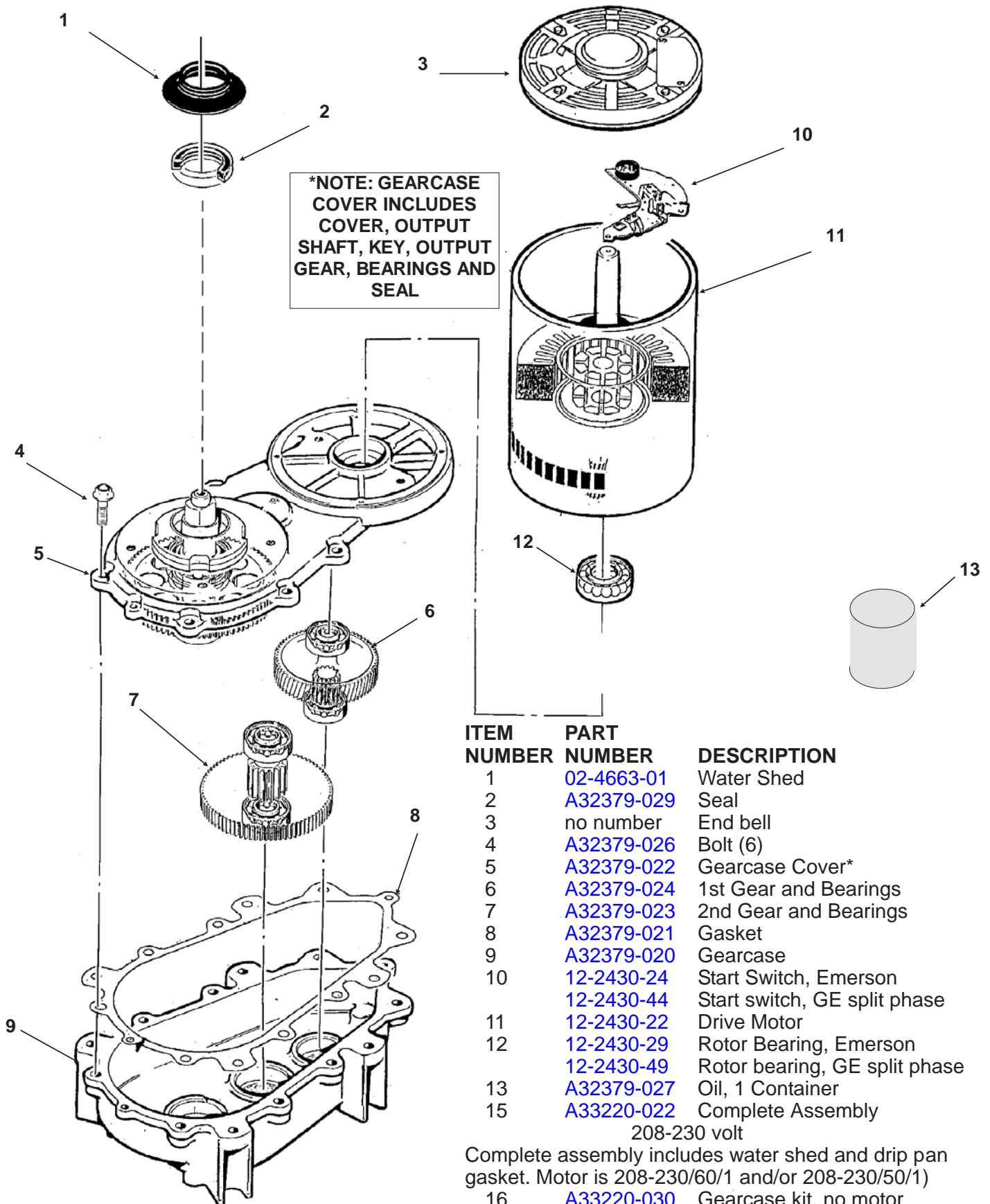

ITEM NUMBER	PART NUMBER	DESCRIPTION
1	02-4663-01	Water Shed
2	A32379-029	Seal
3	no number	End bell
4	A32379-026	Bolt (6)
5	A32379-022	Gearcase Cover*
6	A32379-024	1st Gear and Bearings
7	A32379-023	2nd Gear and Bearings
8	A32379-021	Gasket
9	A32379-020	Gearcase
10	12-2430-24	Start Switch, Emerson
	12-2430-44	Start switch, GE split phase
11	12-2430-22	Drive Motor
12	12-2430-29	Rotor Bearing, Emerson
	12-2430-49	Rotor bearing, GE split phase
13	A32379-027	Oil, 1 Container
15	A33220-022	Complete Assembly

208-230 volt

Complete assembly includes water shed and drip pan gasket. Motor is 208-230/60/1 and/or 208-230/50/1)

16 A33220-030 Gearcase kit, no motor

NME1854 & FME2404 SERVICE PARTS

NME Evaporator

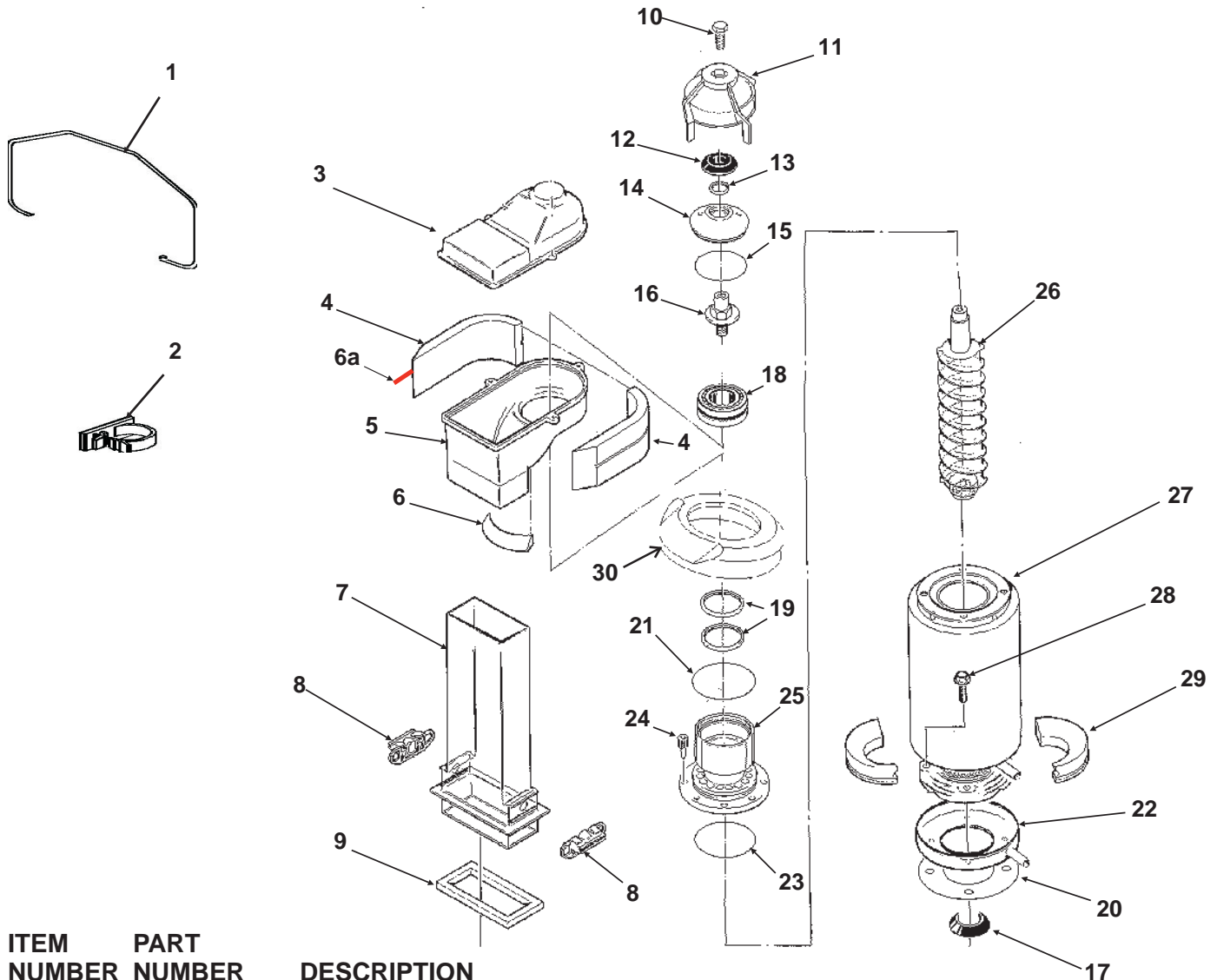

ITEM NUMBER	PART NUMBER	DESCRIPTION
1.	A34969-001	Bail clip
2.	02-3268-01	Drain tube holder
3.	02-2930-04	Ice Chute Cover
4.	A32963-001	Insulation Top (half)*
5.	02-3841-01	Ice Chute Body with ins.*
6.	A33102-001	Insulation Collar Inside*
6a	A35419-020	Strap kit*
7.	02-2929-04	Ice Chute Lower
8.	A37708-021	Bin Controls Assy. (set of 2)
9.	A32930-001	Chute Gasket
10.	03-1405-52	Hex Cap Screw
11.	02-3001-01	Ice Sweep
12.	13-0871-01	Water Shed
13.	02-2978-01	Lip Seal
14.	02-3128-20	Breaker Cover
15.	13-0617-52	O-Ring
16.	08-0660-01	Auger Stud & washer
17.	02-4663-01	Water Shed
18.	A34559-020	Bearing
19.	02-2977-01	Lip Seal
20.	13-0704-00	Drip Pan Gasket
21.	13-0617-54	O-Ring
22.	A37705-021	Drip Pan Kit
23.	13-0617-45	O-Ring
24.	03-1544-08	Soc. Head Screw
25.	A32900-020	Breaker (includes 12-15, 18, 19, 21)
26.	A38071-022	Auger
27.	A32890-020	Evaporator
28.	03-1405-41	Cap Screw
29.	02-4358-01	Insulation
30.	13-0929-02	Insulation donut*

* Insulation changed Oct. 2000

NME1854 & FME2404 SERVICE PARTS

FME Evaporator

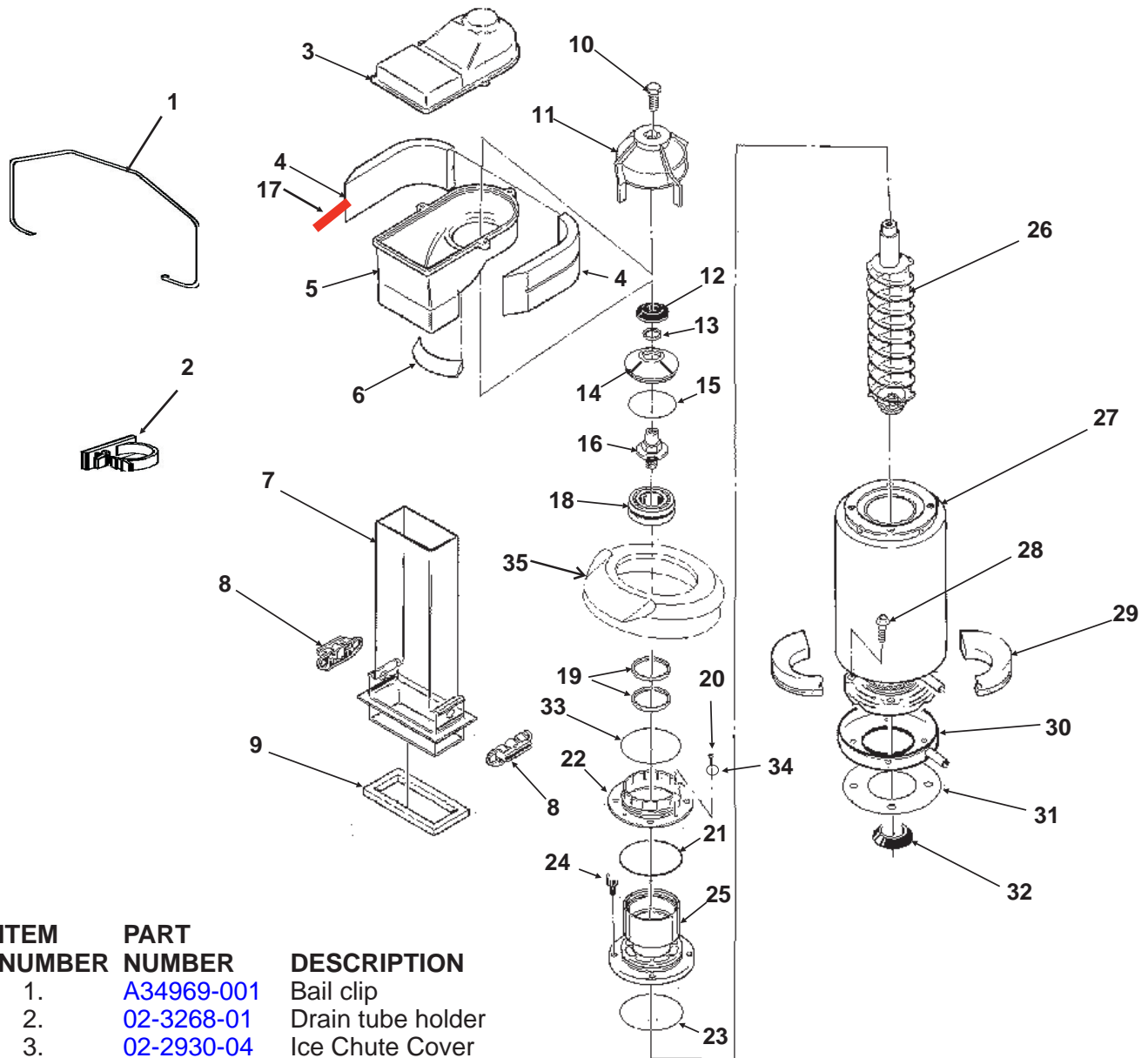

ITEM NUMBER	PART NUMBER	DESCRIPTION
1.	A34969-001	Bail clip
2.	02-3268-01	Drain tube holder
3.	02-2930-04	Ice Chute Cover
4.	A32963-001	Insulation Top (half)*
5.	02-3841-01	Ice Chute Body w/ins.*
6.	A33102-001	Insulation Collar Inside*
7.	02-2929-04	Ice Chute Lower
8.	A37708-021	Bin Controls Assy. (set of 2)
9.	A32930-001	Chute Gasket
10.	03-1405-52	Hex Cap Screw
11.	02-3001-01	Ice Sweep
12.	13-0871-01	Water Shed
13.	02-2978-01	Lip Seal
14.	02-3128-20	Breaker Cover
15.	13-0617-54	O-Ring
16.	08-0660-01	Auger Stud, thrust Washer
17.	A35419-020	Strap kit*
18.	A34559-020	Bearing
19.	02-2977-01	Lip Seal
20.	03-1405-27	Screw
21.	13-0617-52	O-Ring
22.	02-2916-01	Slotted Collar
23.	13-0617-45	O-Ring
24.	03-1544-08	Soc. Head Screw
25.	A34505-020	Breaker (Divider) (includes 12-15, 18,19, 21, 22, 23)
26.	A38071-022	Auger
27.	A32890-020	Evaporator
28.	03-1405-41	Cap Screw
29.	02-4358-01	Insulation
30.	A37705-021	Drip Pan kit
31.	13-0704-00	Drip Pan Gasket
32.	02-4663-01	Water Shed
33.	13-0617-49	O-Ring
34.	03-1408-36	Washer
35.	13-0929-01	Insulation donut*

* Insulation changed Oct. 2000

NME1854 & FME2404 SERVICE PARTS

Control Box

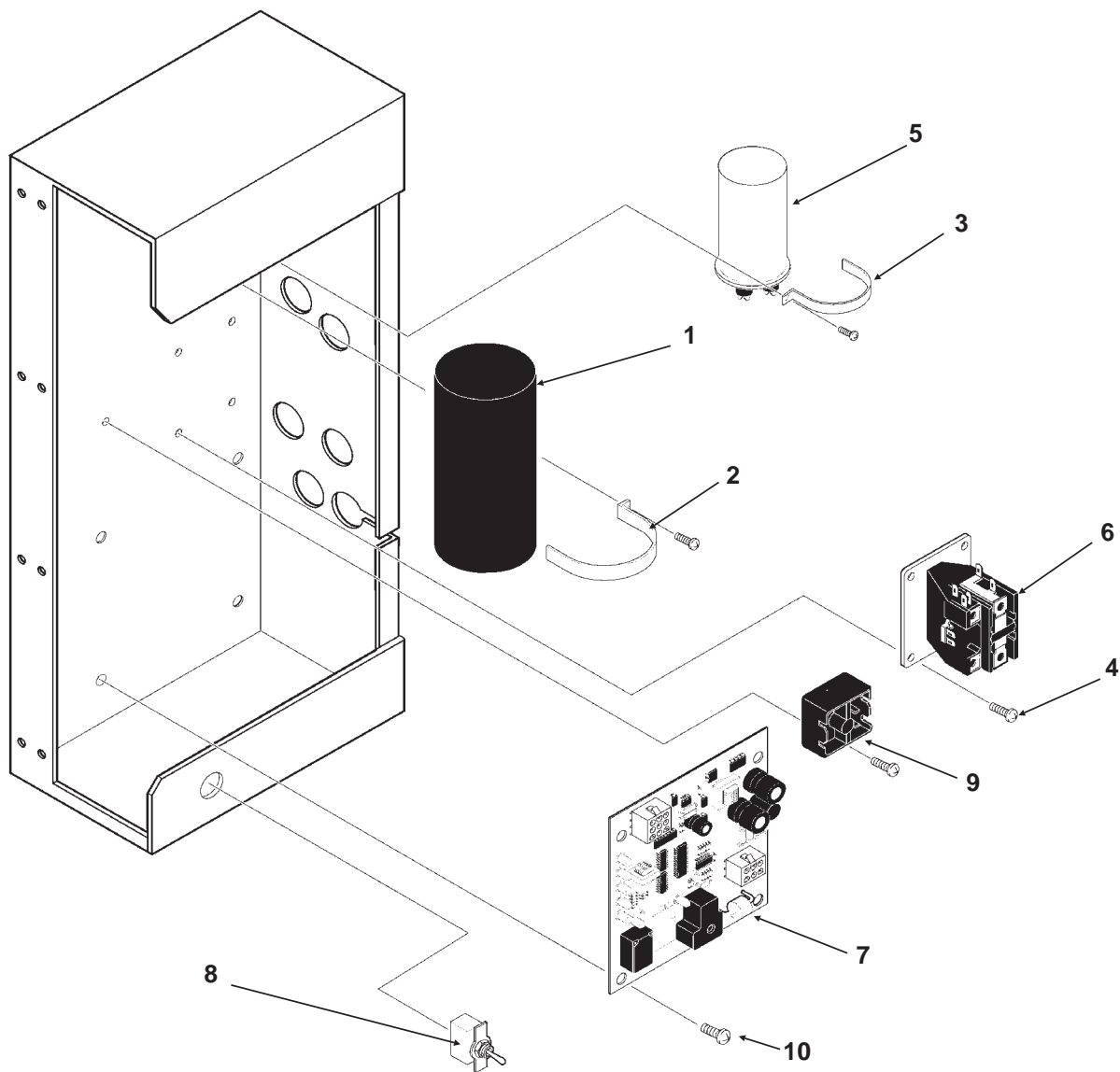

ITEM NUMBER	PART NUMBER	DESCRIPTION
1	see page 10	Start Capacitor, 60 Hz
	see page 10	Start capacitor, 50 Hz
2.	A35971-001	Start Capacitor Bracket
3.	A35971-002	Run Cap Bracket
4.	03-1638-03	Screw
5.	see page 10	Run Capacitor, 60 Hz
	see page 10	Run capacitor, 50 Hz
6.	12-2469-02	Single Phase Contactor
	12-2533-02	Three Phase Contactor

ITEM NUMBER	PART NUMBER	DESCRIPTION
7	12-2835-22	Circuit Board
8.	12-0426-02	Mode Switch
9.	see page 10	Potential Relay 60 Hz
	see page 10	Potential relay, 50 Hz
10	12-2350-01	Stand off

NOT ILLUSTRATED

11	A37861-001	Control Box Cover
----	------------	-------------------

NME1854 & FME2404 SERVICE PARTS

Compressors and Starting Components

RS70 Compressor (example **RS70C1E-PFV-213**), used until mid June 2012. Refer to this parts list for compressor service parts on units manufactured before serial number 12061320011941.

18-8768-22	Compressor 208-230/60/1
18-1901-54	Start Capacitor, 60 Hz
18-1902-45	Run Capacitor, 60 Hz
18-1903-33	Potential Relay 60 Hz Overload is internal
18-8768-24	Compressor 208-230/60/3 Overload is internal
18-8772-26	Compressor 230/50/1
18-1901-53	Start capacitor, 50 Hz
18-1902-53	Run capacitor, 50 Hz
18-1903-29	Potential relay, 50 Hz
18-8772-21	Overload

Note: Replacement compressors include a new dryer, and single phase 60 Hz replacements include the starting components.

Because the RST compressor is not an exact replacement for the RS, the kits below include the tubing and starting components needed to install the RST compressor in place of the RS.

RST70 Compressor, (example **RST70C1E-PFV**) use began with serial number 12061320011941. Refer to this parts list for compressor service parts on any unit after that serial number.

18-8955-22	Compressor 208-230/60/1
18-1901-20	Start Capacitor, 60 Hz
18-1902-67	Run Capacitor, 60 Hz
18-1903-54	Potential Relay 60 Hz Overload is internal
18-8955-23	Compressor 208-230/60/3
18-8955-53	Overload

Note: Replacement compressors include a new dryer, and single phase 60 Hz replacements include the starting components.

No 50 Hz RST compressor was used in production. Continue to use [18-8772-26](#) as a replacement for 50 Hz compressors in these models.

NME1854 & FME2404 SERVICE PARTS

AIR AND WATER COOLED, 208-230/60/1

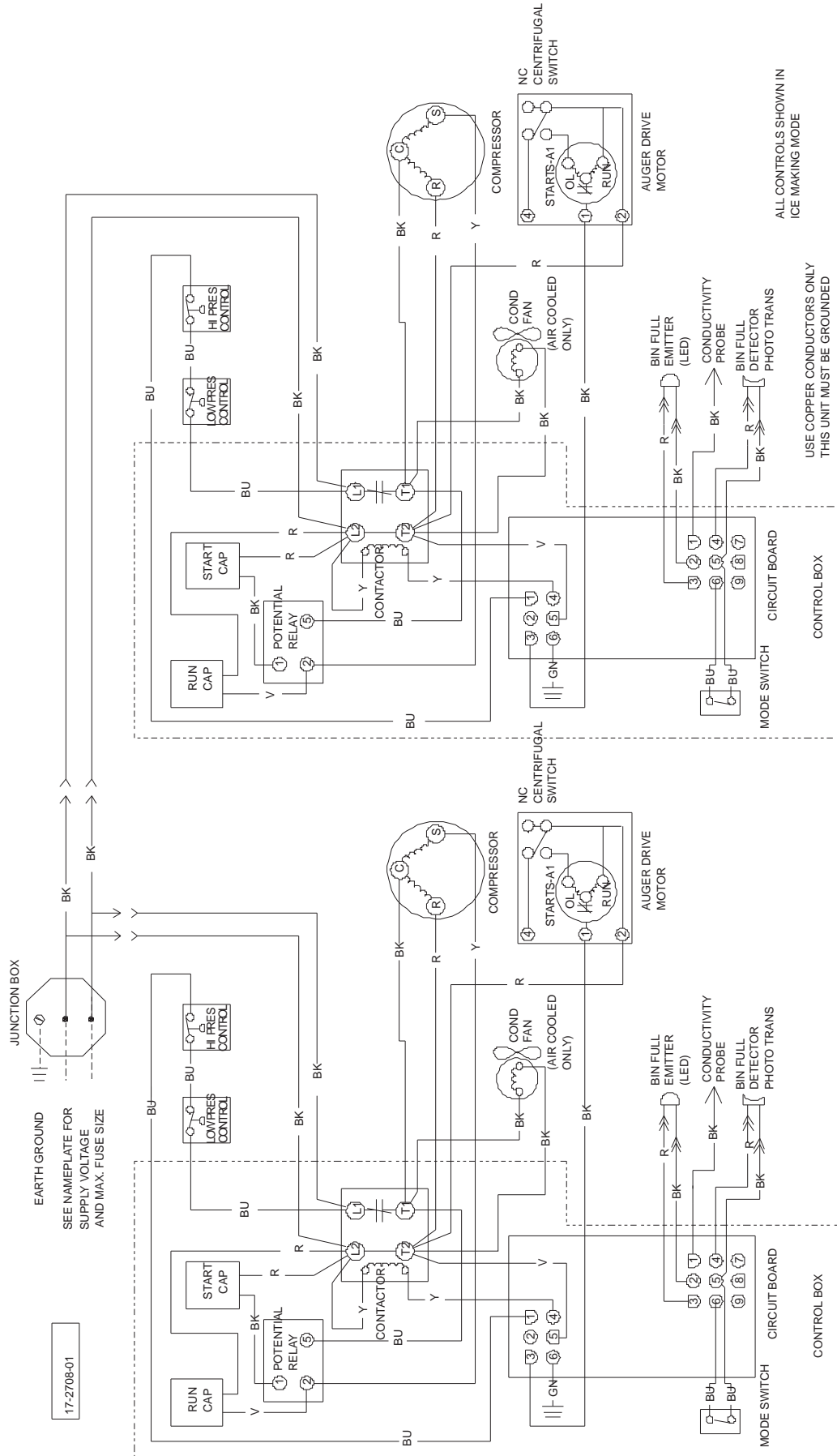

ALL CONTROLS SHOWN IN ICE MAKING MODE

USE COPPER CONDUCTORS ONLY THIS UNIT MUST BE GROUNDED

NME1854 & FME2404 SERVICE PARTS

AIR AND WATER COOLED, 208-230/60/1

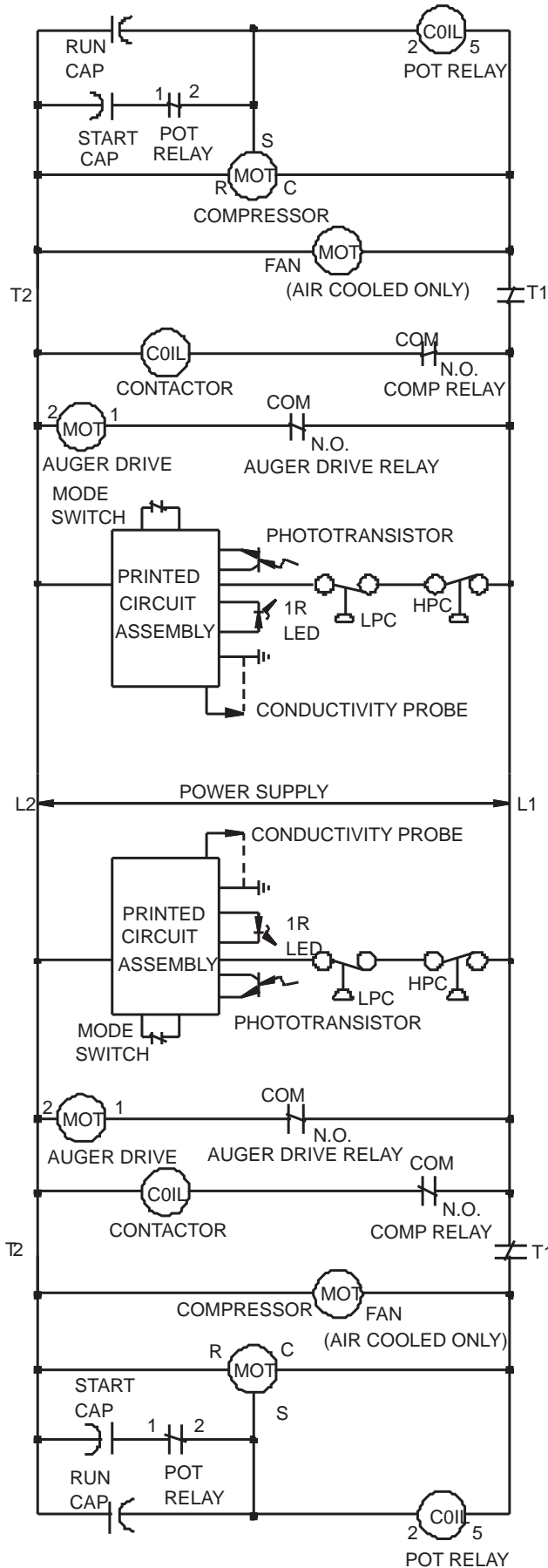

NME1854 & FME2404 SERVICE PARTS

AIR AND WATER COOLED, 208-230/60/3

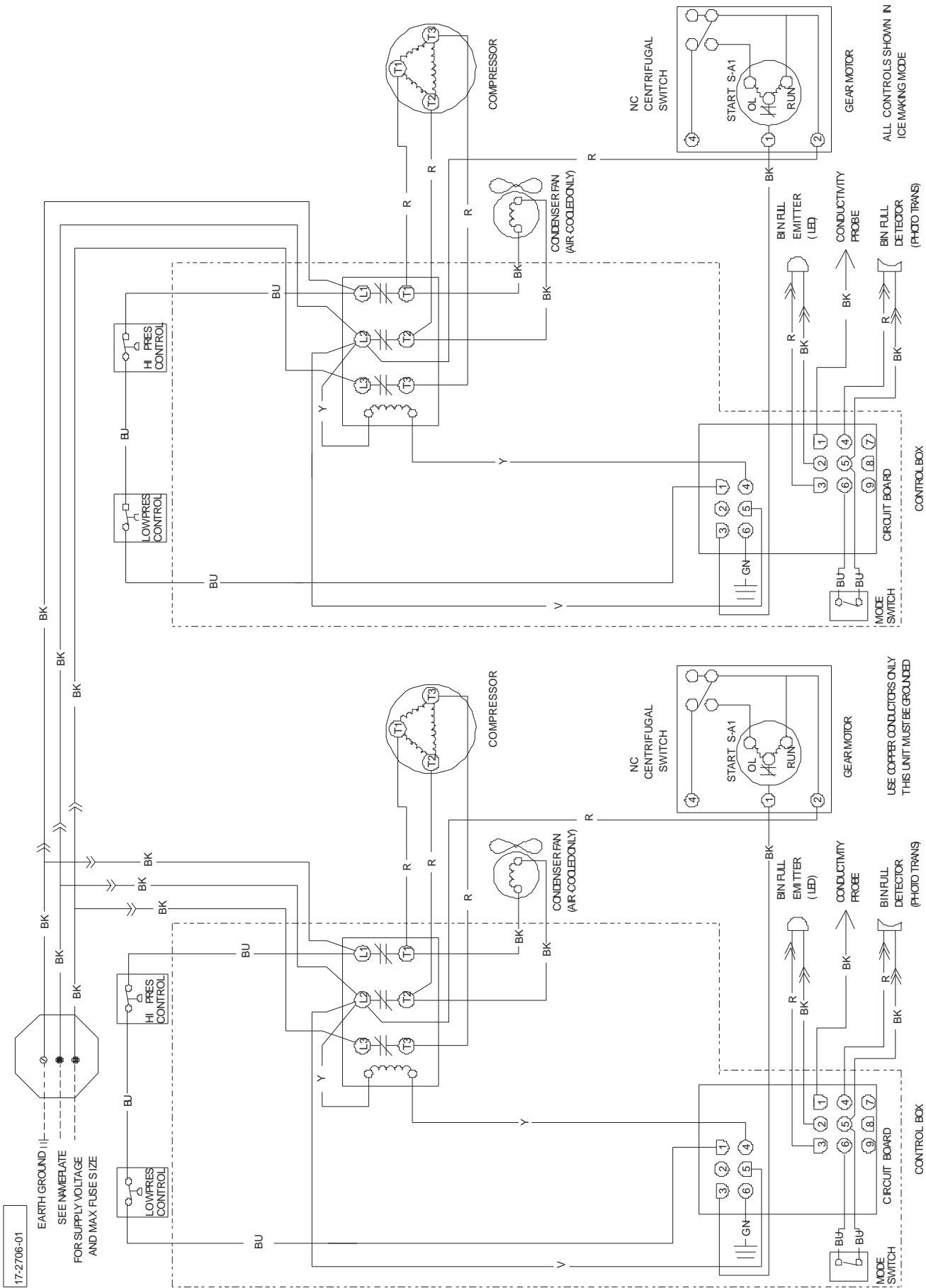

17-2706-01

EARTH GROUND
SEE NME1854
FOR SUPPLY VOLTAGE
AND MAX FUSE SIZE

NME1854 & FME2404 SERVICE PARTS

AIR AND WATER COOLED, 208-230/60/3

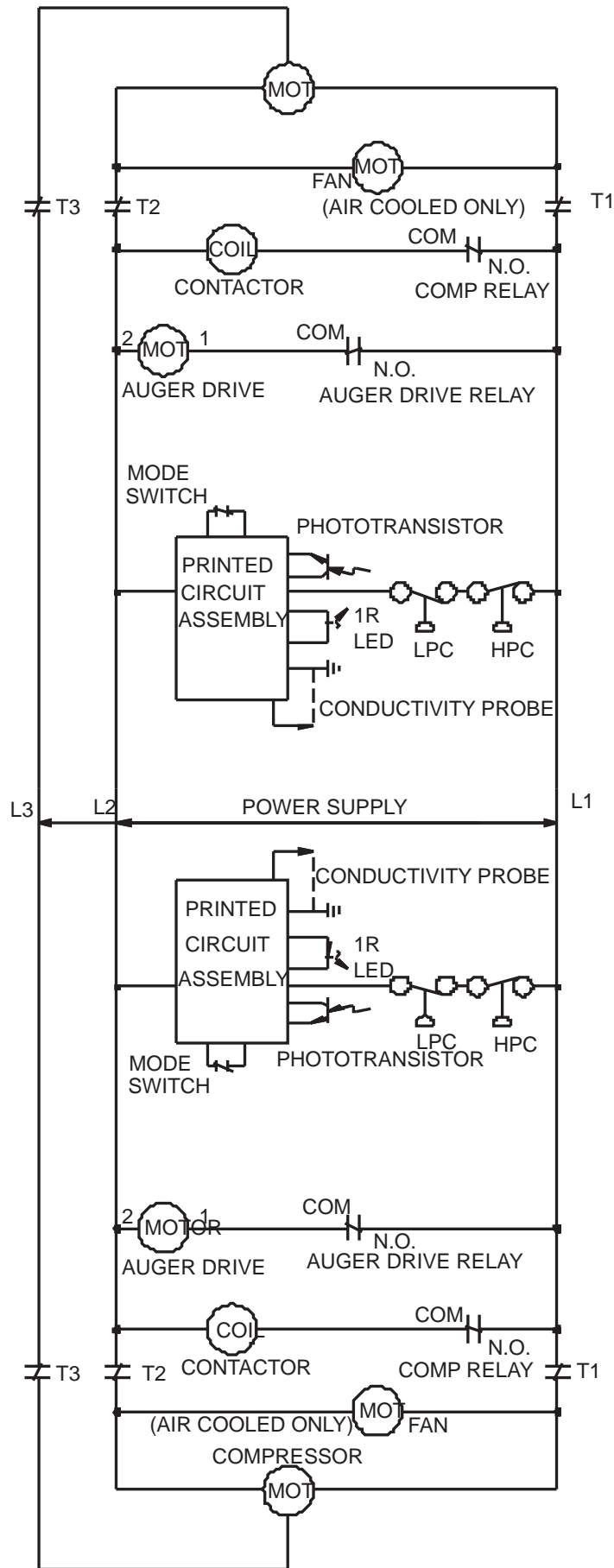

NME1854 & FME2404 SERVICE PARTS

230/50/1

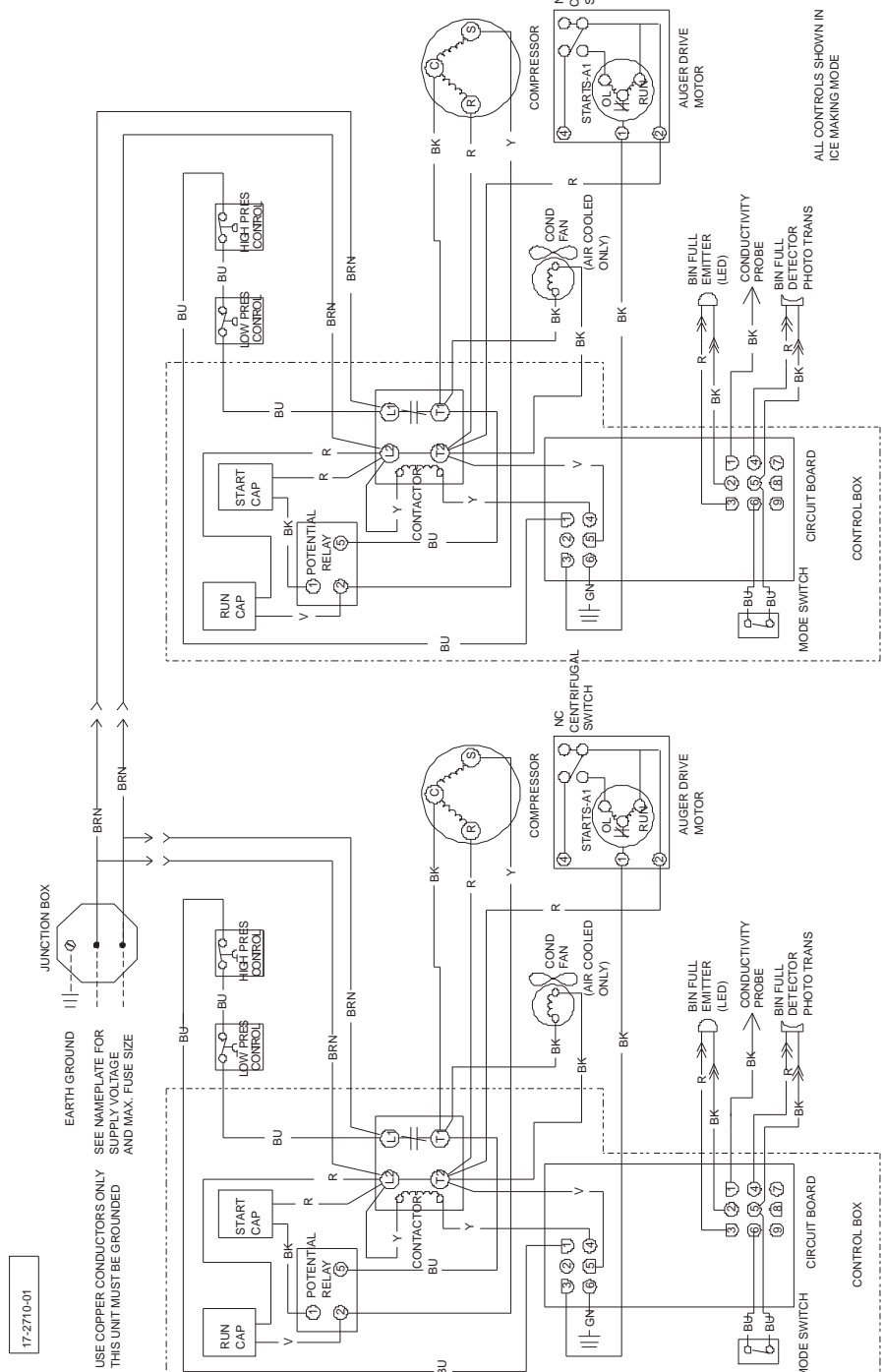
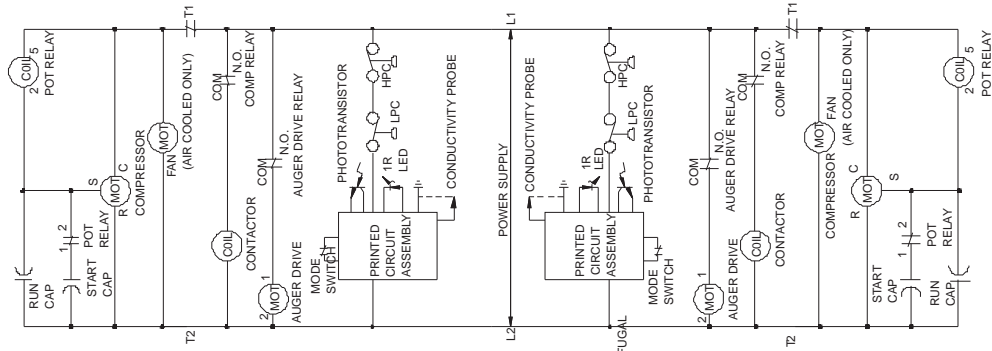

ALL CONTROLS SHOWN IN ICE MAKING MODE

17-2710-01

USE COPPER CONDUCTORS ONLY
THIS UNIT MUST BE GROUNDED