

Prodigy Eclipse ECC, EH330 and EH430 C-E Service Parts

This part list contains the service parts for the Eclipse 1200, 1400, and 1800 systems. D series models began early 2015. E series models began early 2018

The models that are covered include:

- EH330 C-E
- EH430 C-E
- ECC1200
- ECC1400
- Contents

ECC1800

Head voltage is independent of the condensing unit voltage.

Voltage codes:

- 1 = 115/60/1
- 3 = 208-230/60/3
- 6 = 230/50/1
- 32 = 208-230/60/1

EH330 C Cabinet.....	2
EH430 C Cabinet.....	3
EH330 D & E Cabinet.....	4
EH430 D & E Cabinet.....	5
EH330 EH430 C- E Interior Parts.....	6
EH330 and EH430 C-E Refrigeration.....	7
EH330 C-E Evaporator Compartment.....	8
EH430 C-E Evaporator Compartment.....	9
EH330 or EH430 C-E Electrical.....	10
ECC Cabinet and Fan	11
ECC Refrigeration Components.....	12
ECC Compressors.....	13
ECC1200, ECC1410 and ECC1800 Control Box.....	14
EH330 C or EH430 C Schematic Diagram.....	15
EH330 C or EH430 C Wiring Diagram.....	16
EH330 D or EH430 D Schematic Diagram.....	17
EH330 D or EH430 D Wiring Diagram.....	18
ECC1200 C.D and ECC1410 C.D Single Phase Wiring Diagram.....	19
ECC1200 C.D and ECC1410 C.D Single Phase Schematic Diagram	20
ECC1200 C-E, ECC1410 C.D and ECC1800 C-E Three Phase Wiring Diagram.....	21
ECC1200 C-E, ECC1410 C.D and ECC1800 C-E, Three Phase Schematic Diagram	22
ECC1200 E and ECC1410 E Single Phase Wiring Diagram.....	23

Prodigy Eclipse ECC, EH330 and EH430 C-E Service Parts

EH330 C Cabinet

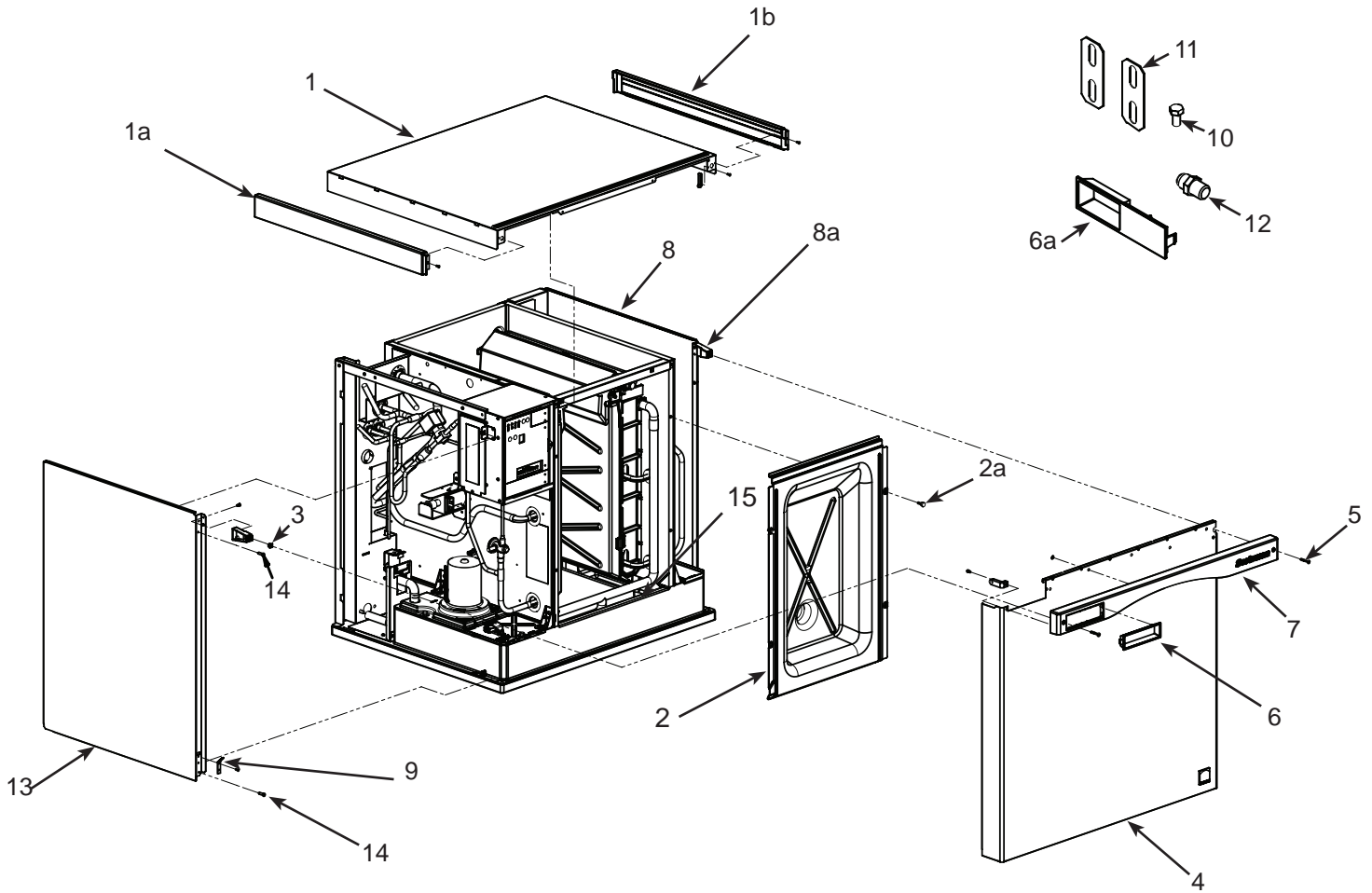

Item Number	Part Number	Description
1	A39579-022	Top panel
2	02-4504-01	Evaporator cover
2a	03-0727-05	Screw
3	03-3804-01	Screw receptacle
4	A39578-022	Front panel assembly, includes trim strip and labels.
4a	02-4216-01	Top gusset
5	03-1735-03	Screw, front panel
6	02-4284-01	Bezel, full window
6a	02-4284-02	Bezel, partial window**
7	02-4214-02	Trim strip
8	A39581-021	Right side panel assy
8a	02-4215-01	Receptacle
9	A39571-001	Panel clip
10	03-1405-15	Screw
11	A30911-015	Machine straps
12	16-0355-00	Inlet water fitting, flare**
13	A39580-022	Left side panel
14	03-1404-12	Screw
15	13-0943-01	Gasket tape

** Optional

Prodigy Eclipse ECC, EH330 and EH430 C-E Service Parts

EH430 C Cabinet

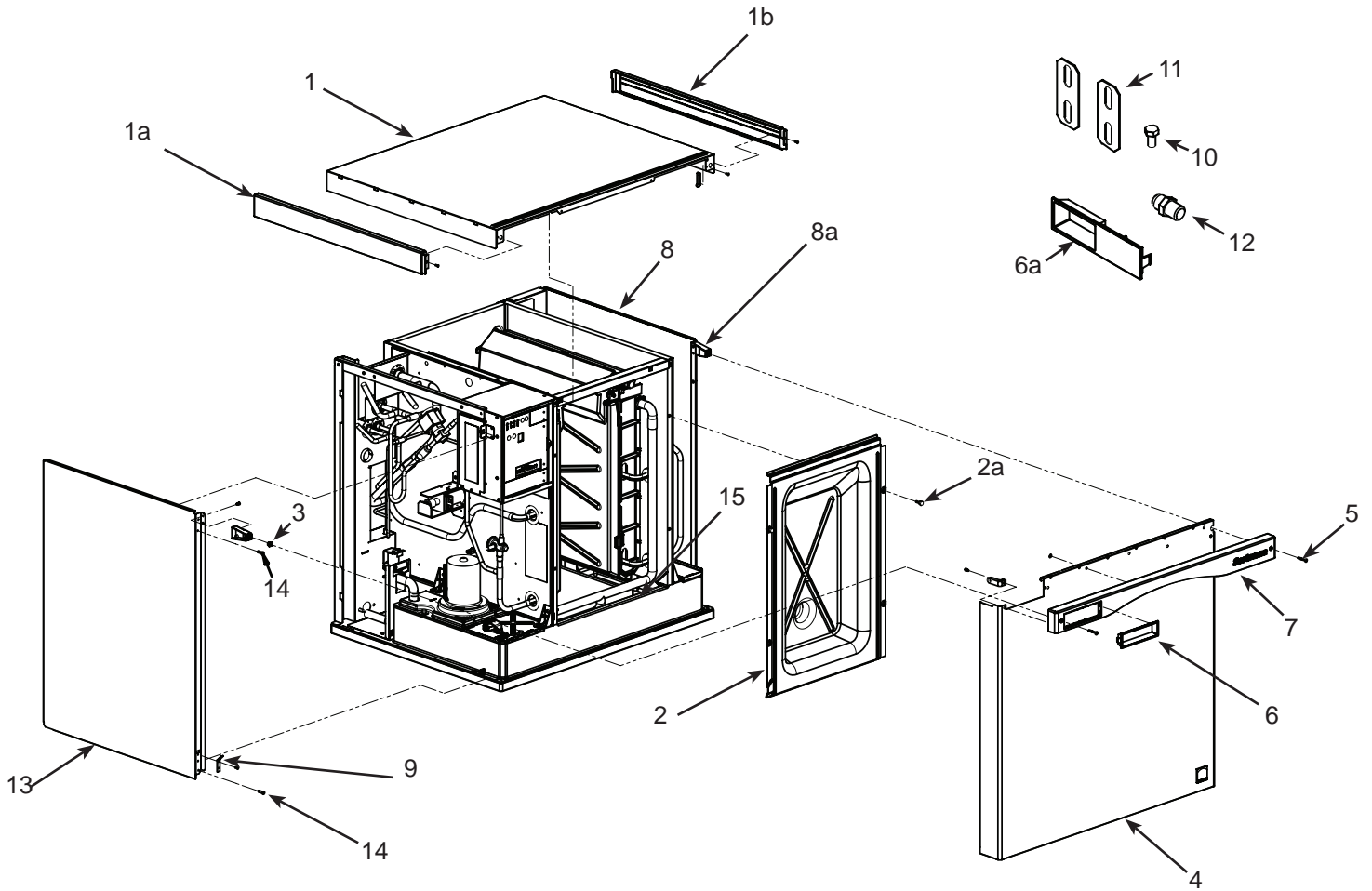

Item Number	Part Number	Description	Item Number	Part Number	Description
1	A39579-022	Top panel, w/trim strips	7	02-4214-02	Trim strip
2	02-4504-01	Evaporator cover	8	A39581-022	Right side panel assy
2a	03-0727-05	Screw	8a	02-4215-01	Receptacle
3	03-3804-01	Screw receptacle	9	A39571-001	Panel clip
4	A39578-023	Front panel assembly, includes trim strip and labels.	10	03-1405-15	Screw
4a	02-4216-01	Top gusset	11	A30911-015	Machine straps
5	03-1735-03	Screw, front panel	12	16-0355-00	Inlet water fitting, flare*
6	02-4284-01	Bezel, full window	13	A39580-024	Left side panel
6a	02-4284-02	Bezel, partial window*	14	03-1404-12	Screw
			15	13-0943-01	Gasket

* Optional

Prodigy Eclipse ECC, EH330 and EH430 C-E Service Parts

EH330 D & E Cabinet

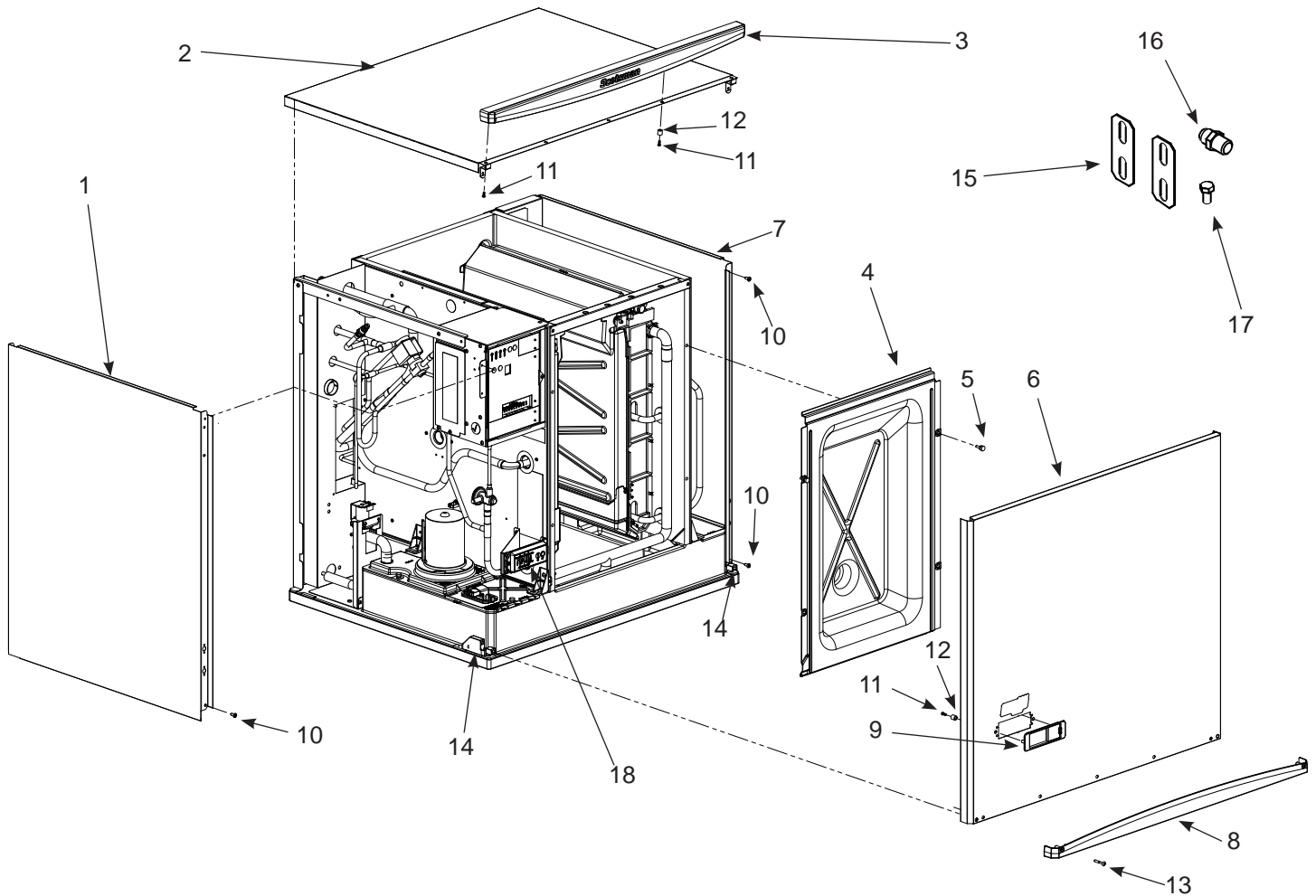

Item Number	Part Number	Description	Item Number	Part Number	Description
1	A40310-021	Left side panel assy	11	03-3836-02	Screw #8 X 3/8
2	A40309-021	Top Panel	12	02-4824-01	Spacer .25 Id X .38 Od
3	02-4819-01	Trim Strip Top	13	03-1735-03	Screw, Front Panel
4	02-4504-01	Inner Front Panel	14	02-4823-21	*Panel mount kit, left
5	03-0727-05	Thumbscrew	14a	02-4823-22	*Panel mount kit, right
6	A40308-033	Front panel assembly, includes trim strip and labels.			*Includes both screw receptacles
7	A40311-021	Right side panel assy	15	A30911-015	Machine straps
8	02-4820-01	Trim Strip Bottom 30"	16	16-0355-00	Inlet water fitting, flare**
9	02-4821-02	Bezel With Standard Door	17	03-1405-15	Screw
9A	02-4822-02	Bezel With Secure Door**	18	11-0622-21	Light & switch panel D & E
10	03-1404-10	Screw #8 X 1/2			** Optional

Prodigy Eclipse ECC, EH330 and EH430 C-E Service Parts

EH430 D & E Cabinet

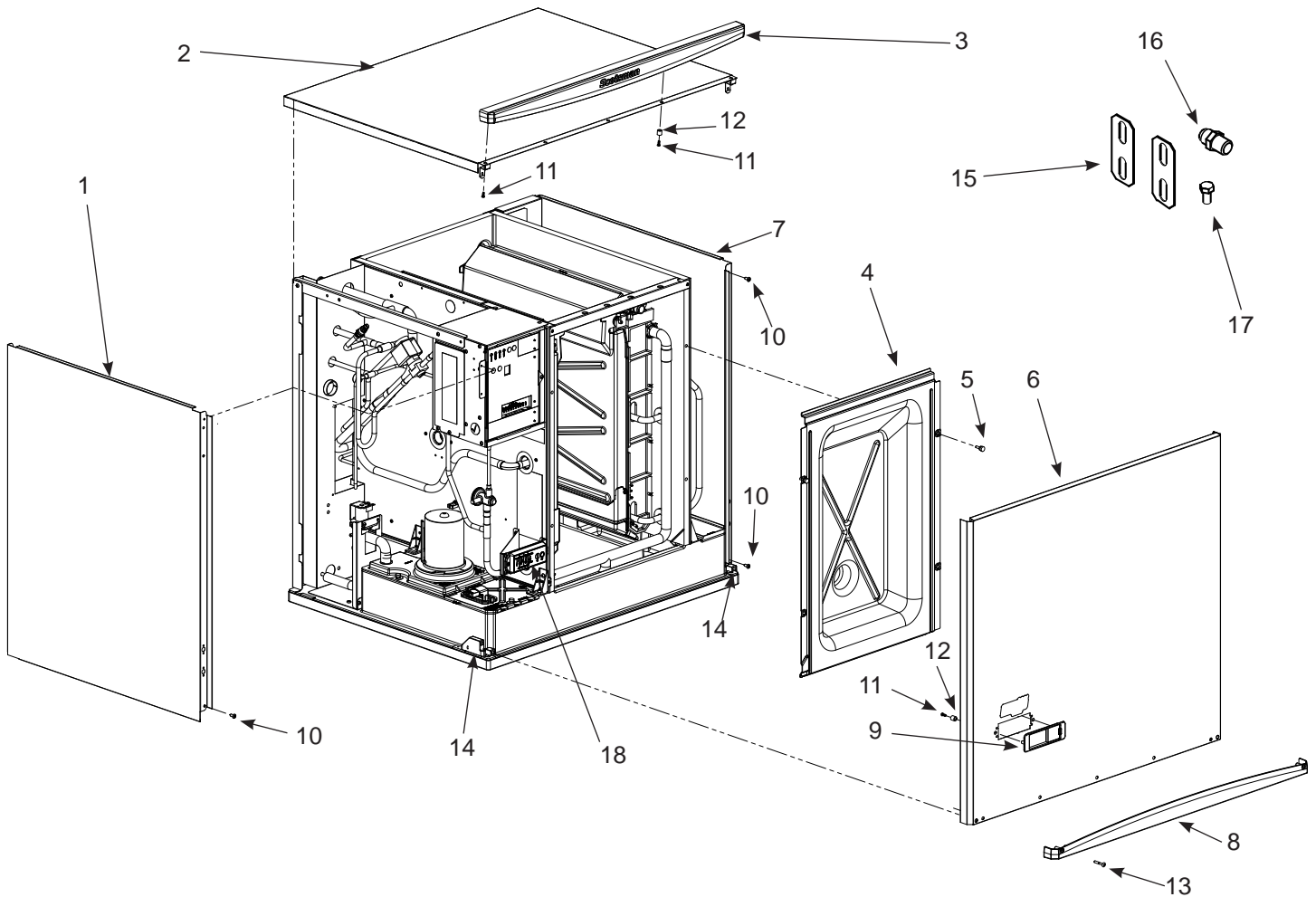

Item Number	Part Number	Description	Item Number	Part Number	Description
1	A40310-022	Left side panel assy	11	03-3836-02	Screw #8 X 3/8
2	A40309-021	Top Panel	12	02-4824-01	Spacer .25 Id X .38 Od
3	02-4819-01	Trim Strip Top	13	03-1735-03	Screw, Front Panel
4	02-4504-01	Inner Front Panel	14	02-4823-21	*Panel mount kit, left
5	03-0727-05	Thumbscrew	14a	02-4823-22	*Panel mount kit, right
6	A40308-034	Front panel assembly, includes trim strip and labels.			*Includes both screw receptacles
7	A40311-022	Right side panel assy	15	A30911-015	Machine straps
8	02-4820-01	Trim Strip Bottom 30"	16	16-0355-00	Inlet water fitting, flare**
9	02-4821-02	Bezel With Standard Door	17	03-1405-15	Screw
9A	02-4822-02	Bezel With Secure Door**	18	11-0622-21	Light & switch panel
10	03-1404-10	Screw #8 X 1/2			** Optional

Prodigy Eclipse ECC, EH330 and EH430 C-E Service Parts

EH330 EH430 C- E Interior Parts

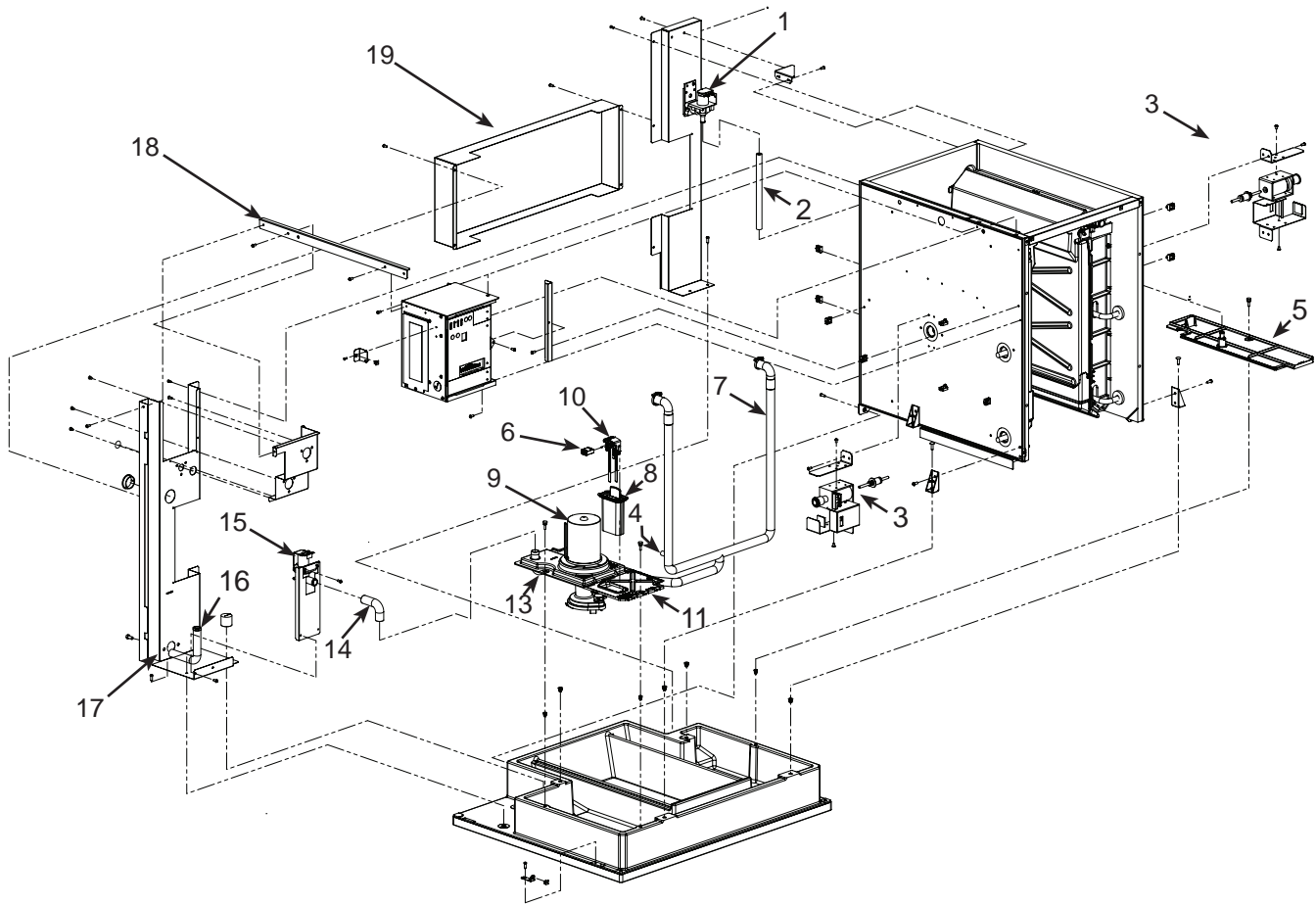

Item Number	Part Number	Description
1	12-2922-01	Inlet water sol valve
2	13-0674-02	Tubing, order 2 (ft)
3	12-3060-21	Harvest assist
4	11-0572-21	Temp sensor set
5	02-4175-01	Sump cover, rt
6	12-2928-01	WLS harness
7	02-4182-01	Water pump hose, EH430
	02-4505-01	Water pump hose, EH330
8	02-4646-01	WLS cover
9	12-2920-21	Water pump
10	A39030-021	Water level sensor
11	02-4649-01	Sump cover
12		
13	02-4177-01	Pump bracket
14	A38863-001	Tube
15	11-0564-01	Purge valve
16	A38863-002	Tube, out
17	02-3692-21	Drain fitting
18	A38804-001	Brace
19	A38796-001	Chase

Prodigy Eclipse ECC, EH330 and EH430 C-E Service Parts

EH330 and EH430 C-E Refrigeration

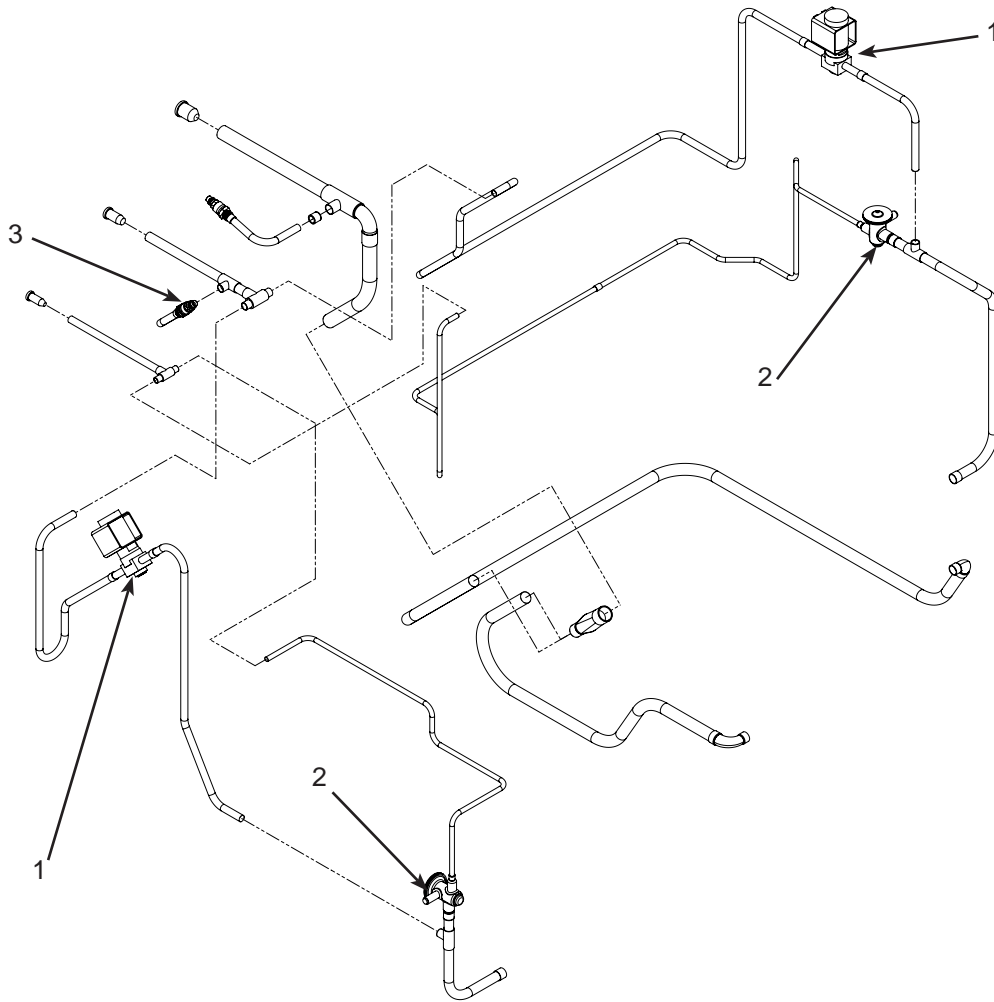

Item Number	Part Number	Description
1	11-0493-03	Vapor valve C or D series
	11-0493-02	Vapor valve E series
2	16-1130-01	TXV - EH430
	16-1142-01	TXV - EH330
	19-0599-06	Insulation for TXV\
3	16-1137-01	Access valve seat
	16-1140-01	Access valve cap
	16-1139-01	Access valve core

Prodigy Eclipse ECC, EH330 and EH430 C-E Service Parts

EH330 C-E Evaporator Compartment

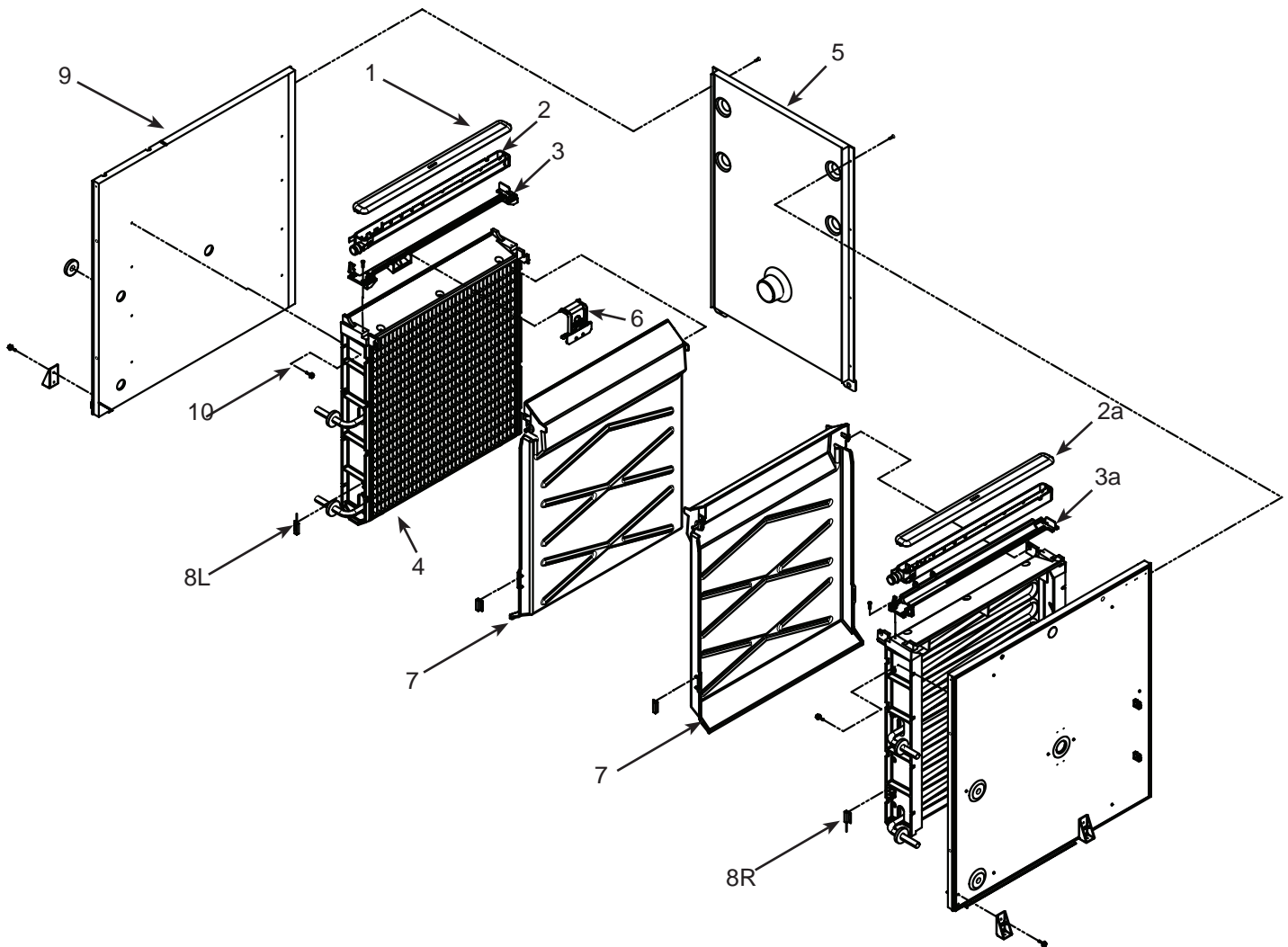

Item Number	Part Number	Description
1	02-4065-01	Water distributor cover
2	02-4064-01	Water distributor, left
2a	02-4064-02	Water distributor, right
3	02-4205-01	Mounting bracket, left
3a	02-4205-02	Mounting bracket, right
4	see table Evaporator	
5	A39480-001	Back wall
6	A39031-021	Ice thickness sensor
7	02-4100-32	Curtain
8L	11-0563-06	Curtain switch, left
8R	11-0563-03	Curtain switch, right
9	13-0943-01	Gasket tape
10	03-3868-01	Screw

	small cube	medium cube
Right	A38627-023	A38627-024
Left	A38627-021	A38627-022

Prodigy Eclipse ECC, EH330 and EH430 C-E Service Parts

EH430 C-E Evaporator Compartment

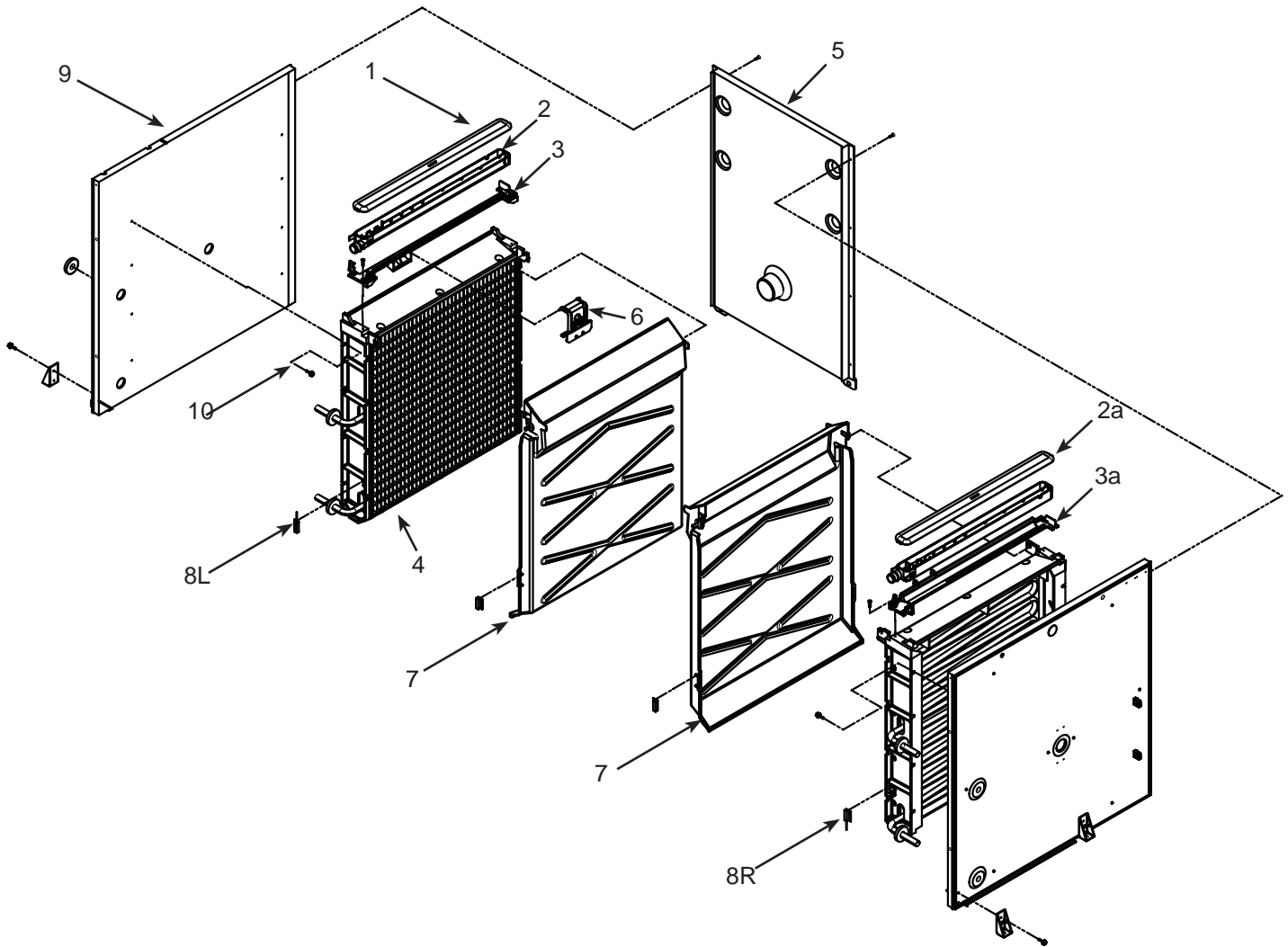

Item Number	Part Number	Description
1	02-4065-01	Water distributor cover
2	02-4064-01	Water distributor, left
2a	02-4064-02	Water distributor, right
3	02-4205-01	Mounting bracket, left
3a	02-4205-02	Mounting bracket, right
4	see table	Evaporator
5	A38677-001	Back wall
6	A39031-021	Ice thickness sensor
7	02-4611-21	Curtain
8L	11-0563-06	Curtain switch, left
8R	11-0563-03	Curtain switch, right
9	13-0943-01	Gasket tape
10	03-3868-01	Screw

	small cube	medium cube
Right	A38628-023	A38628-024
Left	A38628-021	A38628-022

Prodigy Eclipse ECC, EH330 and EH430 C-E Service Parts

EH330 or EH430 C-E Electrical

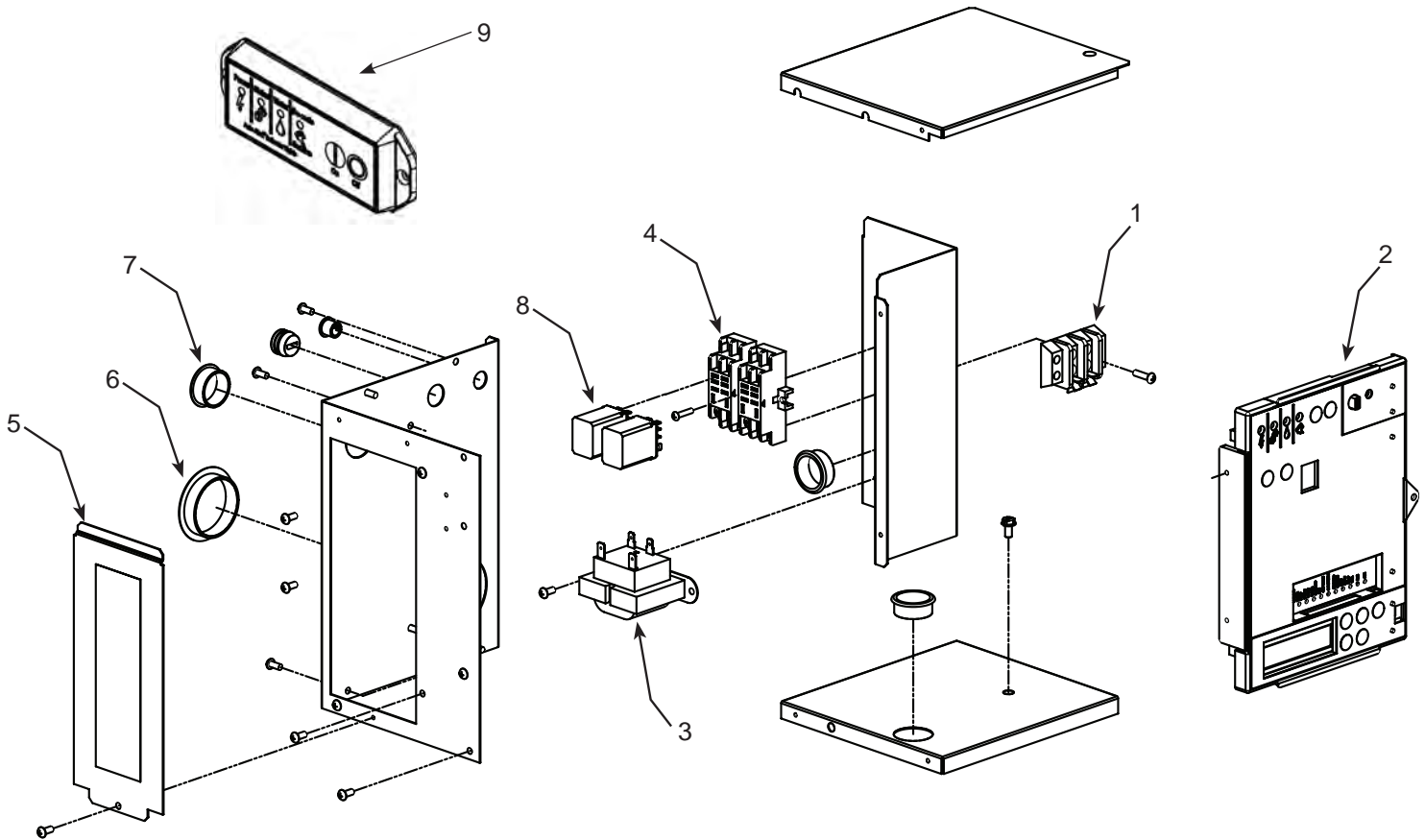

Item Number	Part Number	Description
1	12-2780-01	Terminal strip
2	11-0621-21	Service controller, fits all
2a	11-0550-28	Service controller, thru C
3	12-2924-01	Transformer
4	12-2949-02	Relay base
5	A39287-001	Cover
6	12-1213-15	Snap bushing
7	12-1213-11	Snap bushing
8	12-2949-01	Relay
9	11-0622-21	Light & switch panel D & E
Not Illustrated:		
10	12-2954-01	Low voltage harness - to interconnecting wire
11	12-2943-01	High voltage harness (has large plug)
12	12-2940-01	Control power harness
13	12-1638-19	Power cord

Prodigy Eclipse ECC, EH330 and EH430 C-E Service Parts

ECC Cabinet and Fan

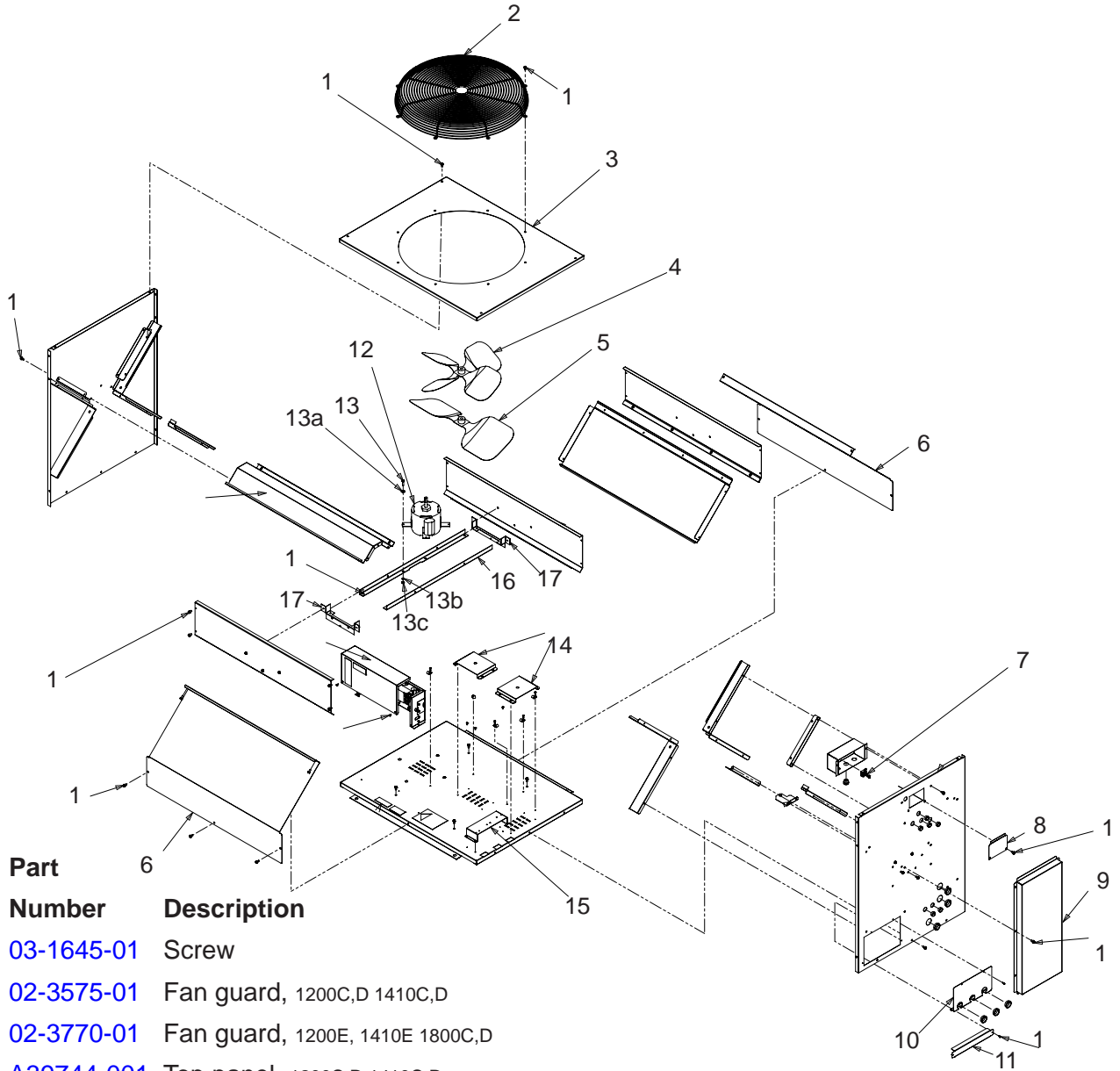

Item Number	Part Number	Description
1	03-1645-01	Screw
2	02-3575-01	Fan guard, 1200C,D 1410C,D
	02-3770-01	Fan guard, 1200E, 1410E 1800C,D
3	A39744-001	Top panel, 1200C,D 1410C,D
	A39744-002	Top panel, 1200E, 1410E 1800C,D
4	18-8816-01	Fan blade, 1200C,D 1410C,D
5	18-8820-01	Fan blade, 1200E, 1410E 1800C,D
6	A40100-001	Cover
7	12-2640-01	Terminal strip, 50 Hz only
8	A37128-001	Box cover
9	A40091-001	Chase cover
10	A40094-001	Valve cover
11	A40106-001	Lower cover
12	12-2651-03	Fan motor, 1200C,D 1410C,D
	12-3135-01	Fan motor, 1200E, 1410E
	12-2949-04	Fan Relay used on E series
	12-2717-02	Fan motor, 1800C,D
13	03-1405-08	Hex bolt
13a	03-1407-06	Flat washer
13b	03-1410-03	Lock washer
13c	03-1406-08	Nut
14	A37948-001	Bracket
15	A40093-001	Bracket
16	A39749-001	Motor bracket
17	A37282-001	Support

Prodigy Eclipse ECC, EH330 and EH430 C-E Service Parts

ECC Refrigeration Components

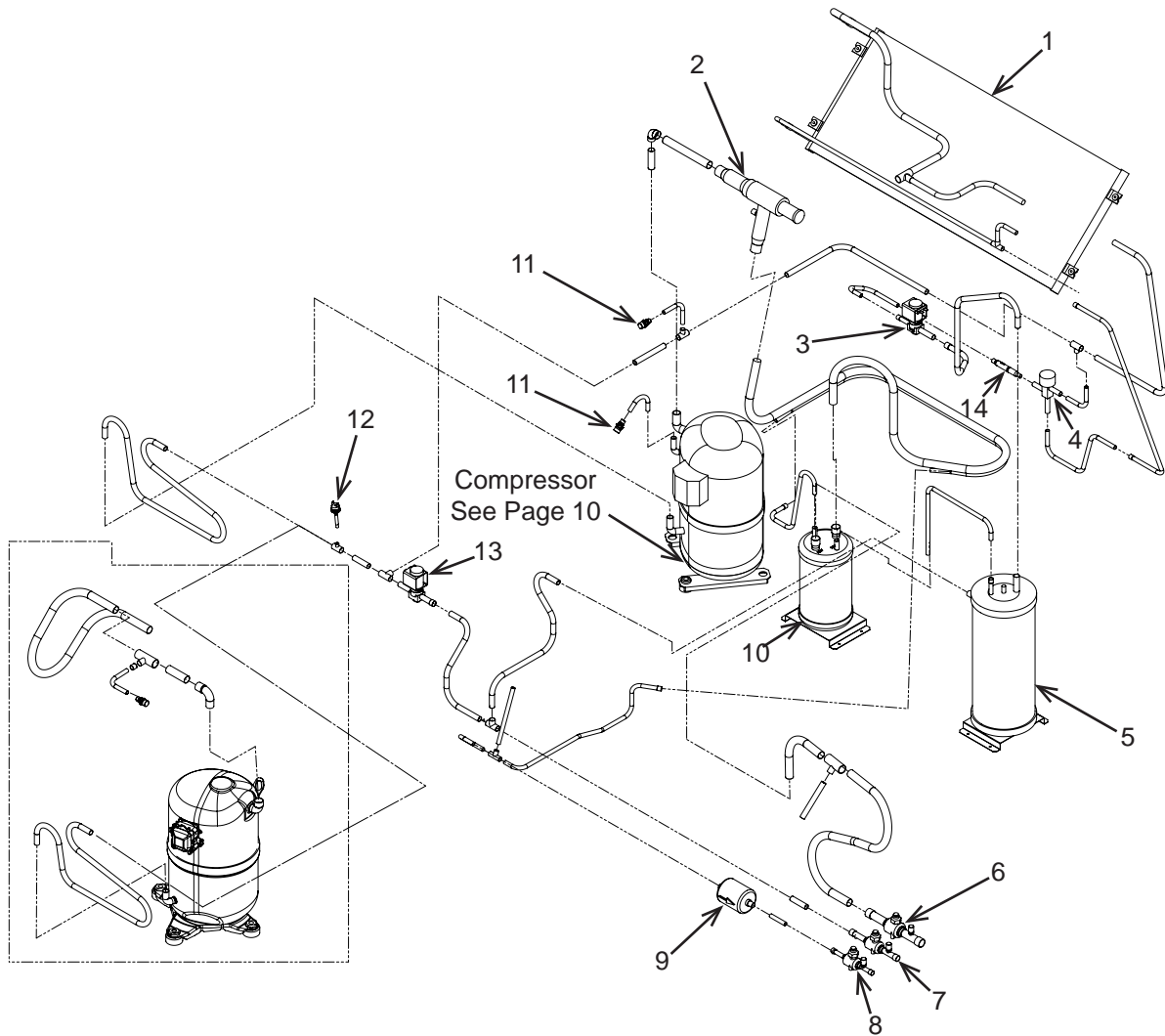

Item Number	Part Number	Description
1	18-8945-22	Coil
2	16-1096-01	CPR valve
3	11-0546-01	Liquid line inlet valve
4	11-0422-22	Head master valve
5	16-1085-03	Receiver
6	16-1208-03	Ball valve 3/4
7	16-1208-02	Ball valve 1/2
8	16-1208-01	Ball valve 3/8
9	02-3319-02	Dryer
10	16-1157-01	Accumulator, 1200, 1410
	16-1122-01	Accumulator, 1800
11	16-1137-01	Access valve seat
	16-1139-01	Access valve core
	16-1140-01	Access valve cap
12	11-0501-02	High pressure cut out switch
13	11-0507-03	Bypass valve
14	16-1029-01	Check valve

November 2014

Prodigy Eclipse ECC, EH330 and EH430 C-E Service Parts

ECC Compressors

Compressor - see table below

Model	Series	Phase	Hz	Part Number
ECC1200-32	C,D	single	60	18-8750-22
ECC1200-32	E	single	60	18-8749-22
ECC1410-32	C,D	single	60	18-8965-21
ECC1410-32	E	single	60	18-8726-23
ECC1410-3	C,D	three	60	18-8965-22
ECC1410-3	E	three	60	18-8726-25
ECC1800-3	C,D & E	three	60	18-8930-25

Single phase 60 Hz compressors include starting components.

All include a drier.

All have internal overloads

[12-3043-03](#) Crankcase heater for 18-8730-25, [18-8750-22](#) and 18-8726-xx

[18-2308-01](#) Crankcase heater for 18-8749-xx

Mounting parts for compressors:

[18-2300-27](#) Mounting grommet

[18-2300-26](#) Sleeve

03-1406-07 Washer

[03-1405-20](#) Cap screw

Parts shipped in condensing unit:

[12-2865-01](#) 75' Interconnecting harness

Prodigy Eclipse ECC, EH330 and EH430 C-E Service Parts

ECC1200, ECC1410 and ECC1800 Control Box

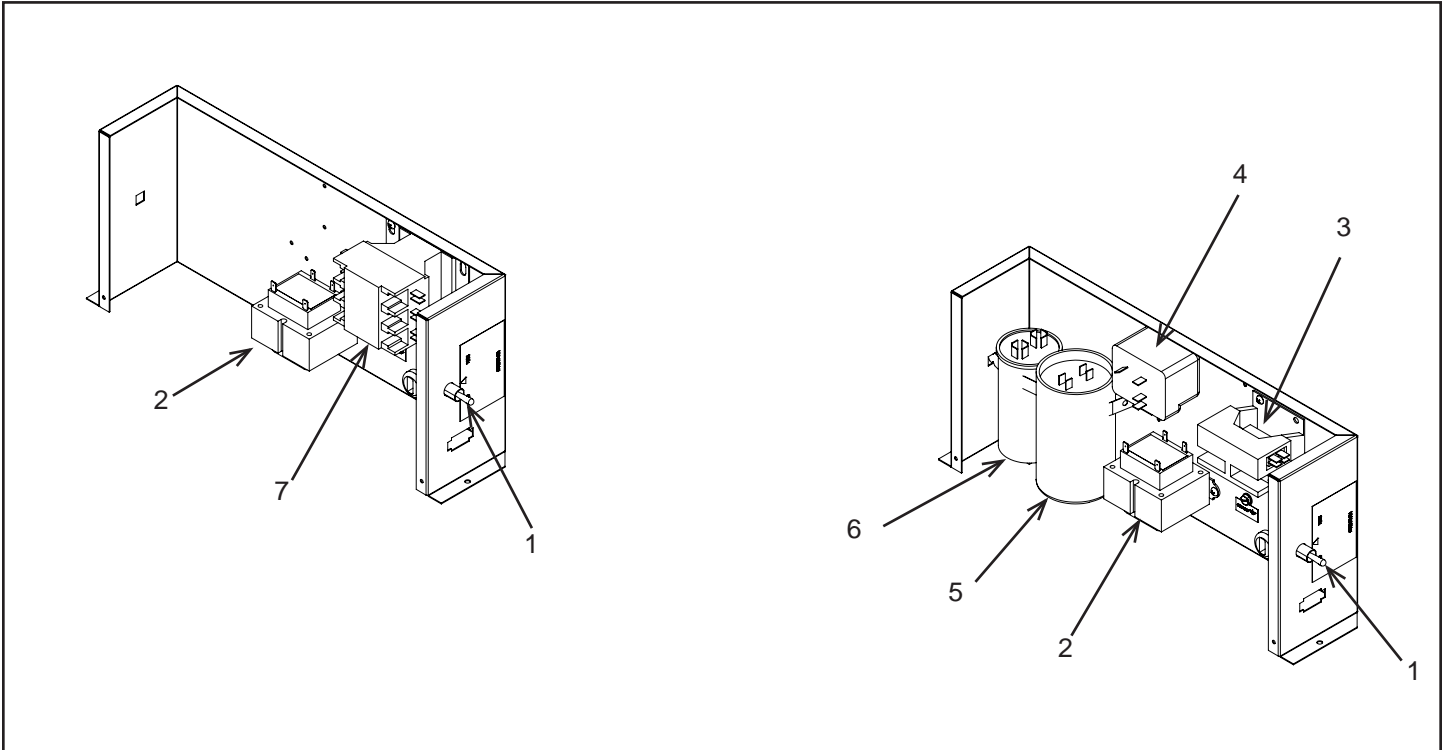

Three Phase Control Box

Single Phase Control Box

Item Number	Part Number	Description
1	12-2637-01	Toggle switch
2	12-2836-02	Transformer, 60 Hz models 230 volt to 24 volt
3	12-2469-01	Single phase contactor

	Item #4	Item #5	Item #6
	Comp. Relay	Start Capacitor	Run Capacitor
ECC1200-32A	18-1903-46	18-1901-48	18-1902-70
ECC1200-32E	18-1902-70	19-1901-48	18-1903-46
ECC1410-32A	18-1903-72	18-1901-59	18-1902-69
ECC1410-32E	18-1903-33	18-1901-15	18-1902-69

7 [12-2533-01](#) Contactor, 3 phase

Prodigy Eclipse ECC, EH330 and EH430 C-E Service Parts

EH330 C or EH430 C Schematic Diagram

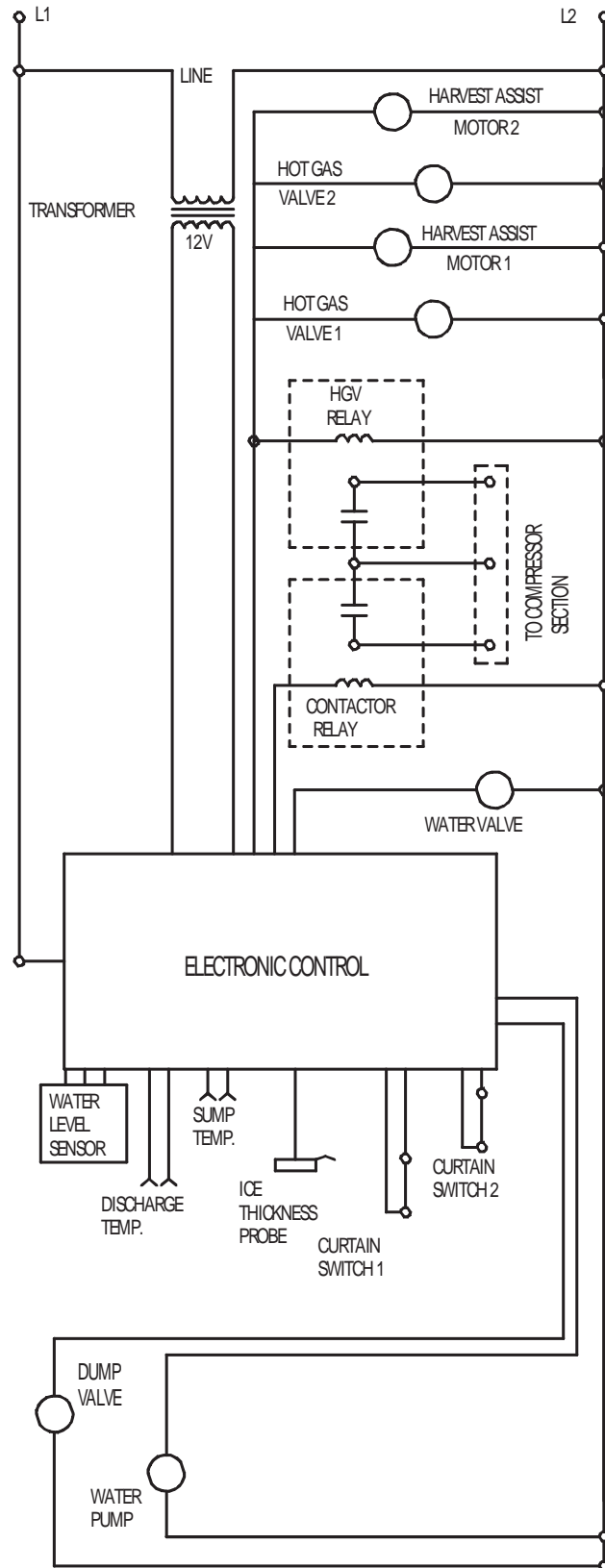

Prodigy Eclipse ECC, EH330 and EH430 C-E Service Parts EH330 D or EH430 D Wiring Diagram

17-3512-01

USE COPPER CONDUCTORS ONLY

△ DASHED LINES INDICATE FIELD WIRING WHICH MUST BE INSTALLED IN ACCORDANCE WITH THE NATIONAL ELECTRICAL CODE AND ALL STATE AND LOCAL CODES.

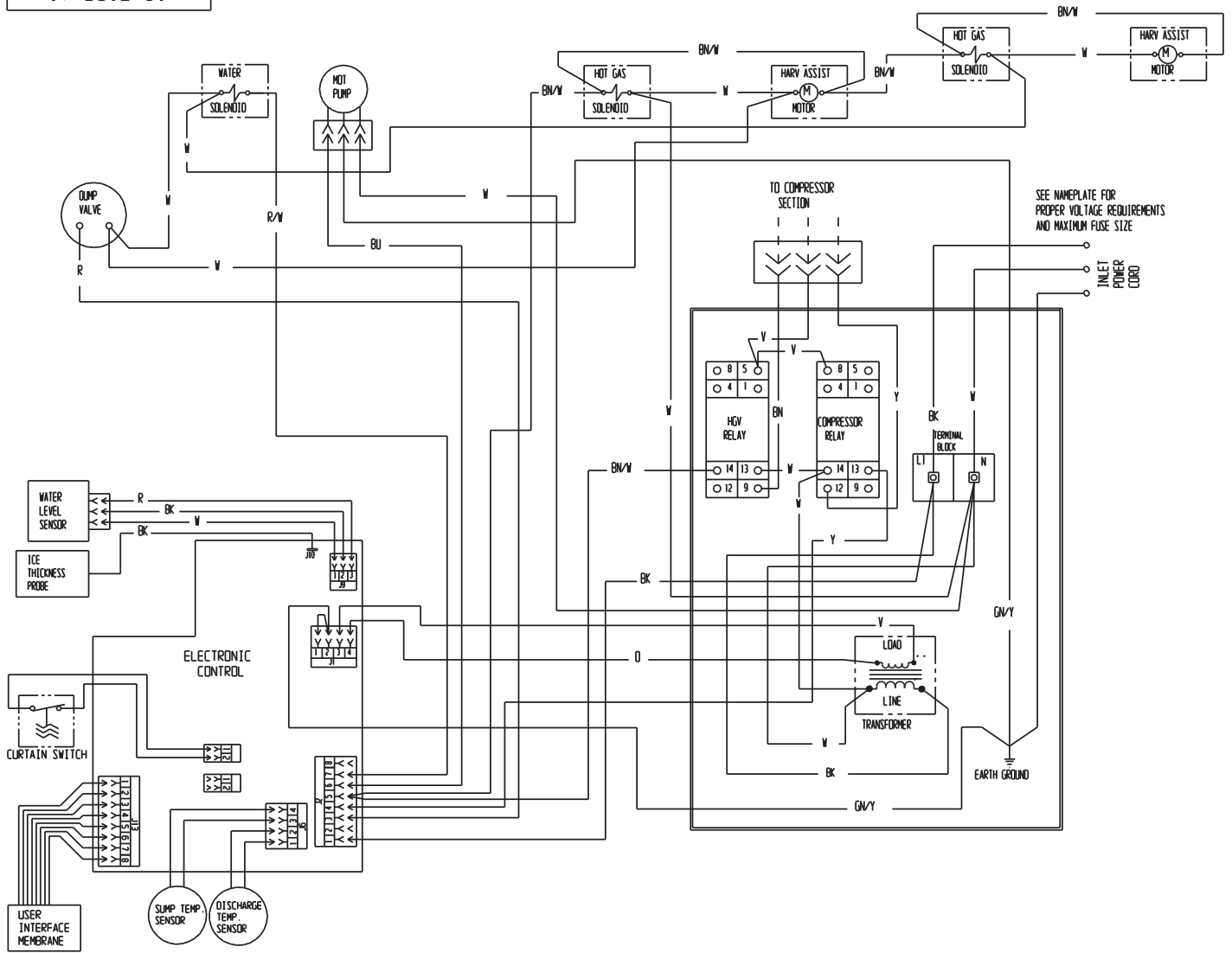

SEE NAMEPLATE FOR PROPER VOLTAGE REQUIREMENTS AND MAXIMUM FUSE SIZE

INLET POWER CORD

THIS UNIT MUST BE GROUNDED.

CAUTION:

MORE THAN ONE DISCONNECT MEANS MAY BE REQUIRED TO DISCONNECT ALL POWER TO THIS UNIT.

Prodigy Eclipse ECC, EH330 and EH430 C-E Service Parts ECC1200 C.D and ECC1410 C.D Single Phase Wiring Diagram

17-3461-01

USE COPPER CONDUCTORS ONLY

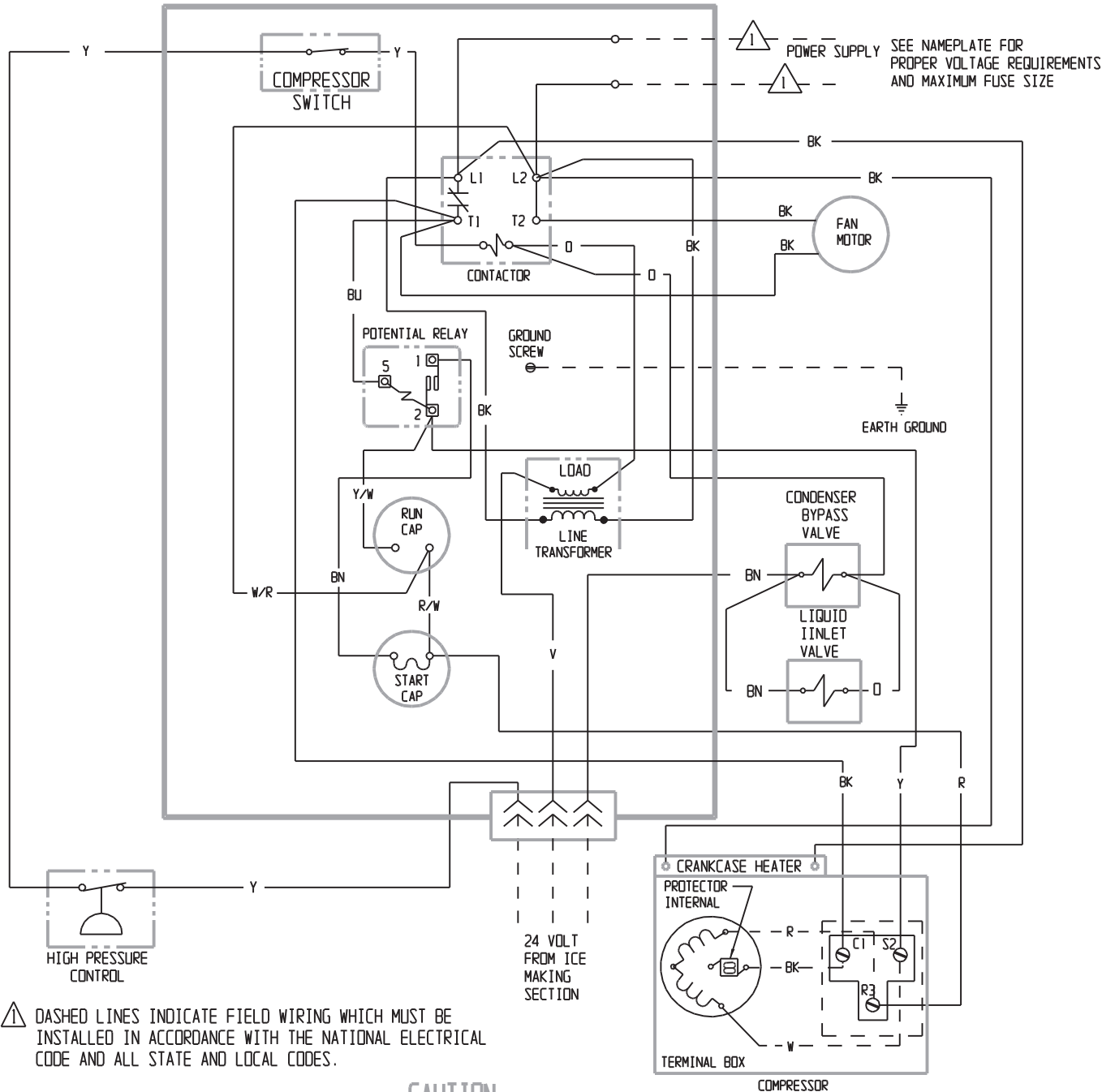

⚠ DASHED LINES INDICATE FIELD WIRING WHICH MUST BE INSTALLED IN ACCORDANCE WITH THE NATIONAL ELECTRICAL CODE AND ALL STATE AND LOCAL CODES.

CAUTION:

MORE THAN ONE DISCONNECT MEANS MAY BE REQUIRED TO DISCONNECT ALL POWER TO THIS UNIT.

THIS UNIT MUST BE GROUNDED.

Prodigy Eclipse ECC, EH330 and EH430 C-E Service Parts

ECC1200 C.D and ECC1410 C.D Single Phase Schematic Diagram

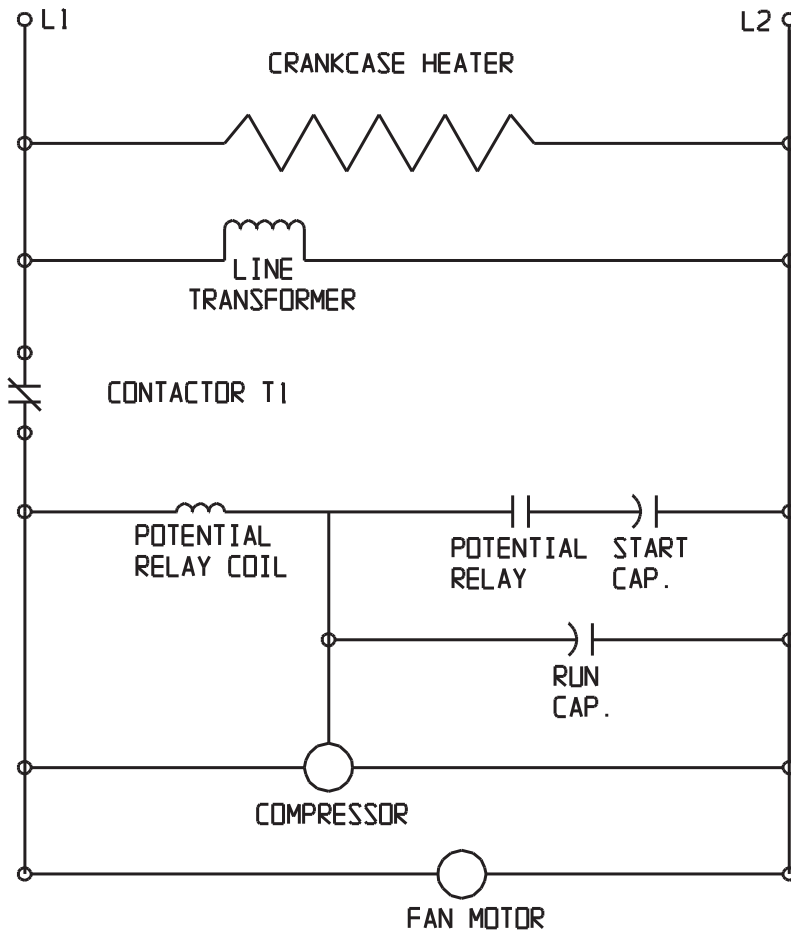
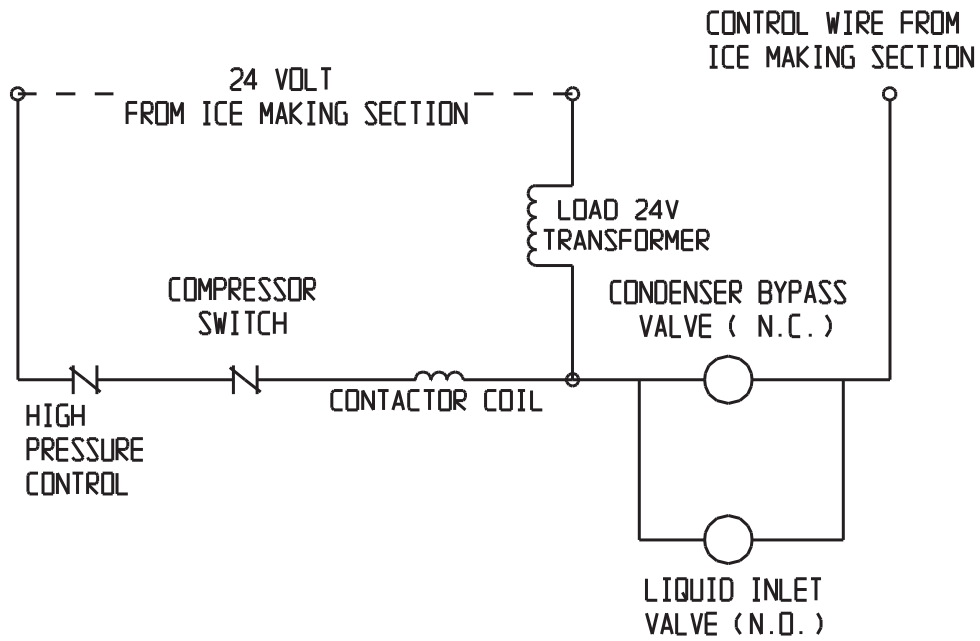

Prodigy Eclipse ECC, EH330 and EH430 C-E Service Parts

ECC1200 C-E, ECC1410 C.D and ECC1800 C-E, Three Phase Schematic Diagram

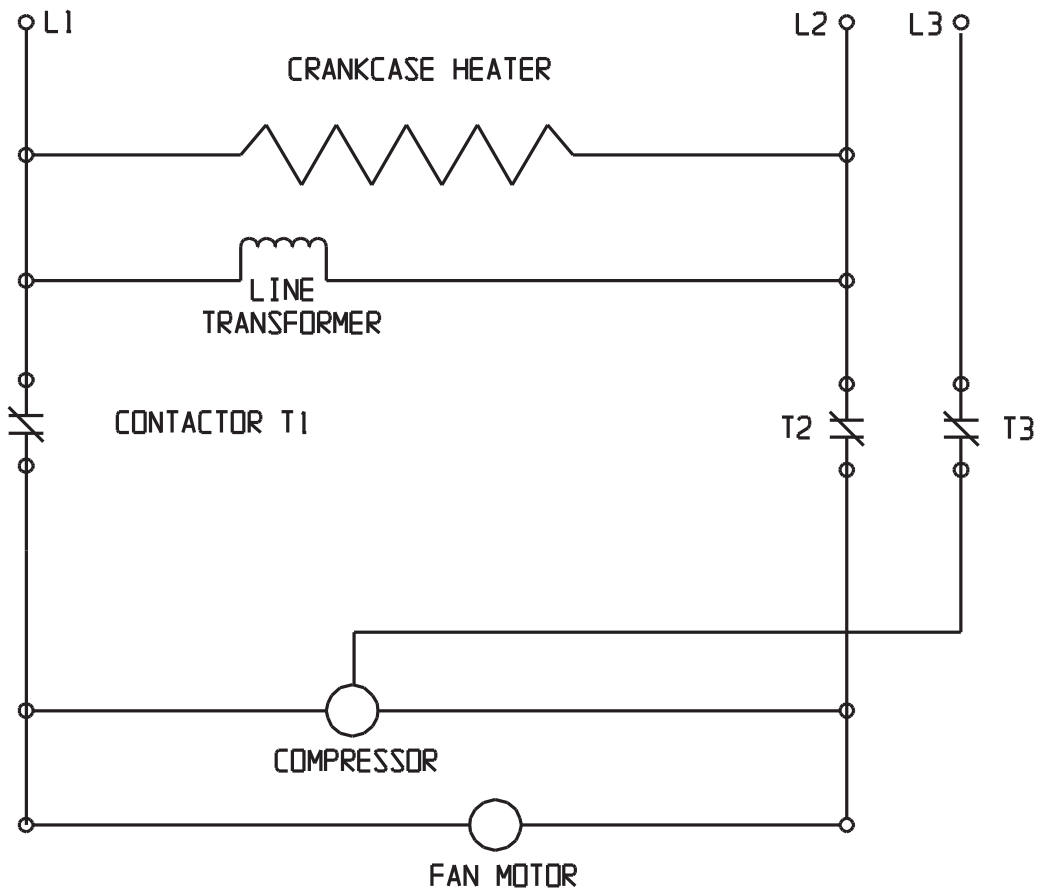
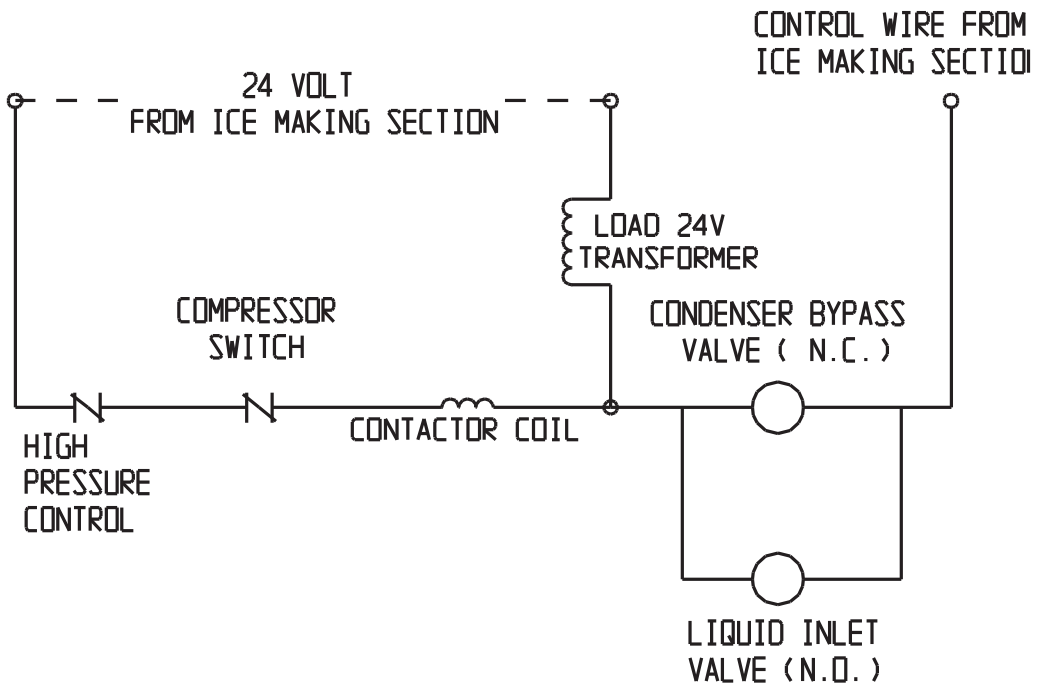

Prodigy Eclipse ECC, EH330 and EH430 C-E Service Parts

ECC1200 E and ECC1410 E Single Phase Wiring Diagram

17-3653-01

USE COPPER CONDUCTORS ONLY

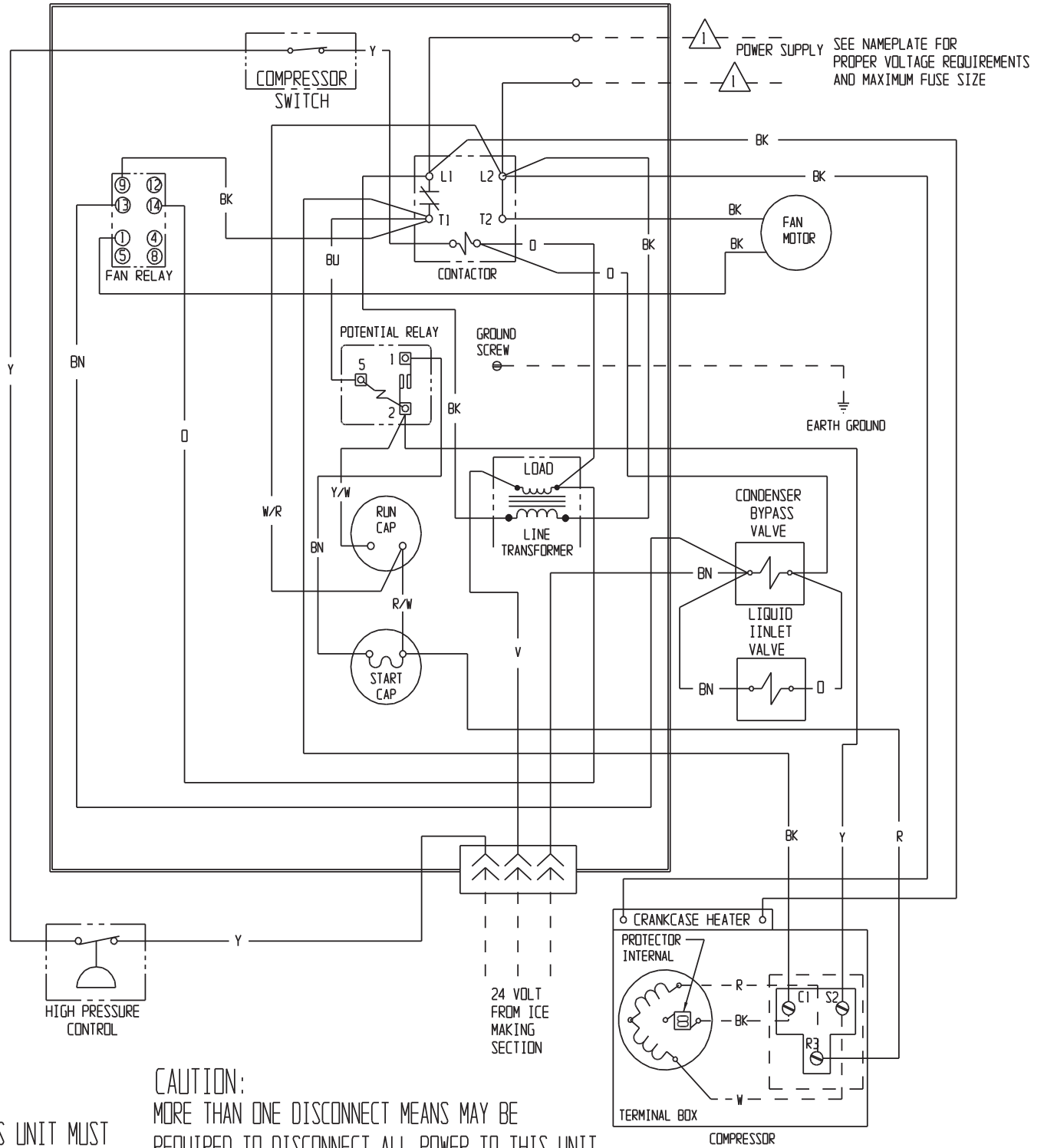

THIS UNIT MUST BE GROUNDED.

CAUTION:
MORE THAN ONE DISCONNECT MEANS MAY BE REQUIRED TO DISCONNECT ALL POWER TO THIS UNIT.

Prodigy Eclipse ECC, EH330 and EH430 C-E Service Parts

ECC1200 E and ECC1410 E Single Phase Wiring Diagram

⚠ DASHED LINES INDICATE FIELD WIRING WHICH MUST BE INSTALLED IN ACCORDANCE WITH THE NATIONAL ELECTRICAL CODE AND ALL STATE AND LOCAL CODES.

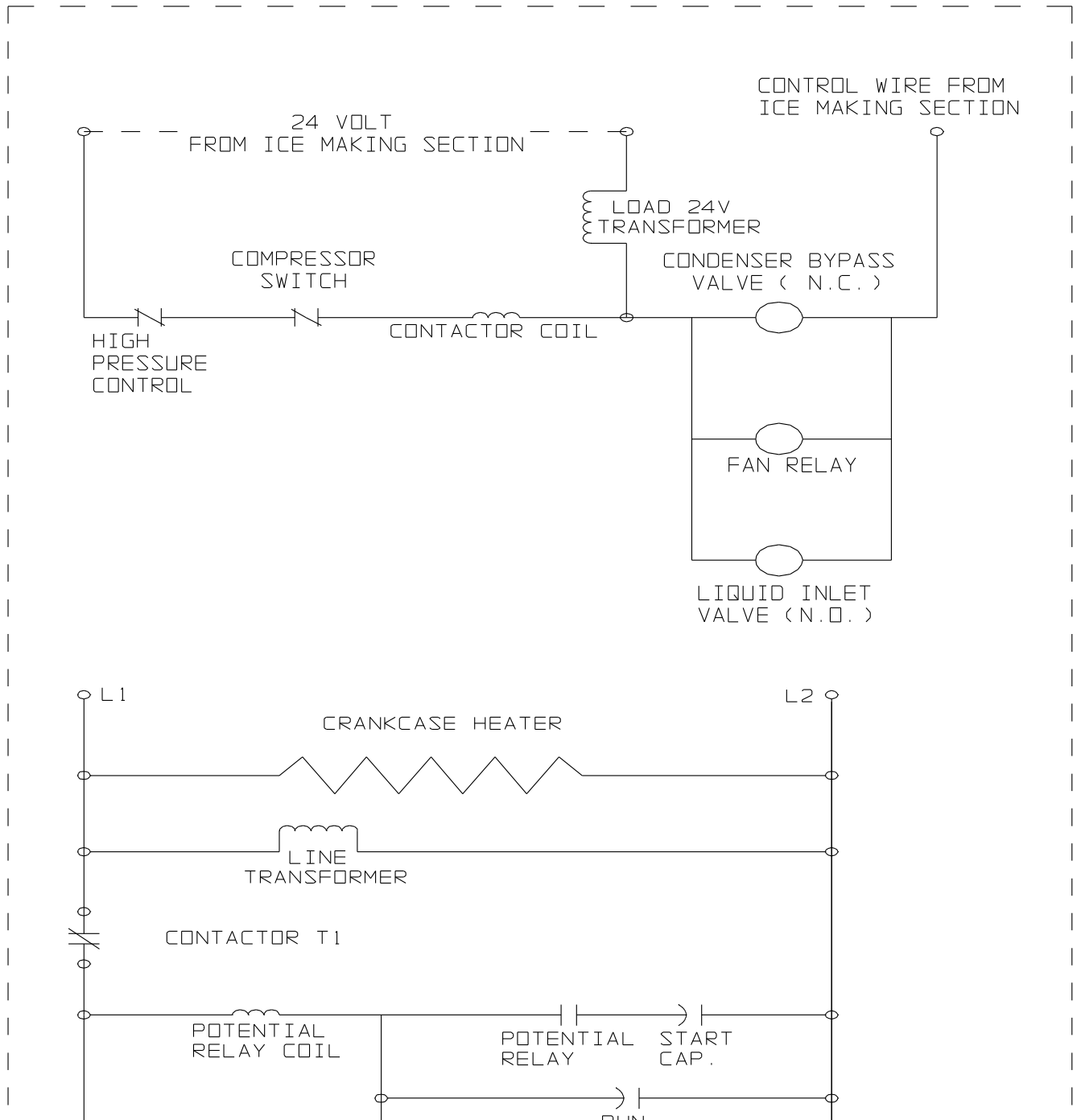

Prodigy Eclipse ECC, EH330 and EH430 C-E Service Parts

ECC1410 E Three Phase Schematic Diagram

17-3652-01

USE COPPER CONDUCTORS ONLY

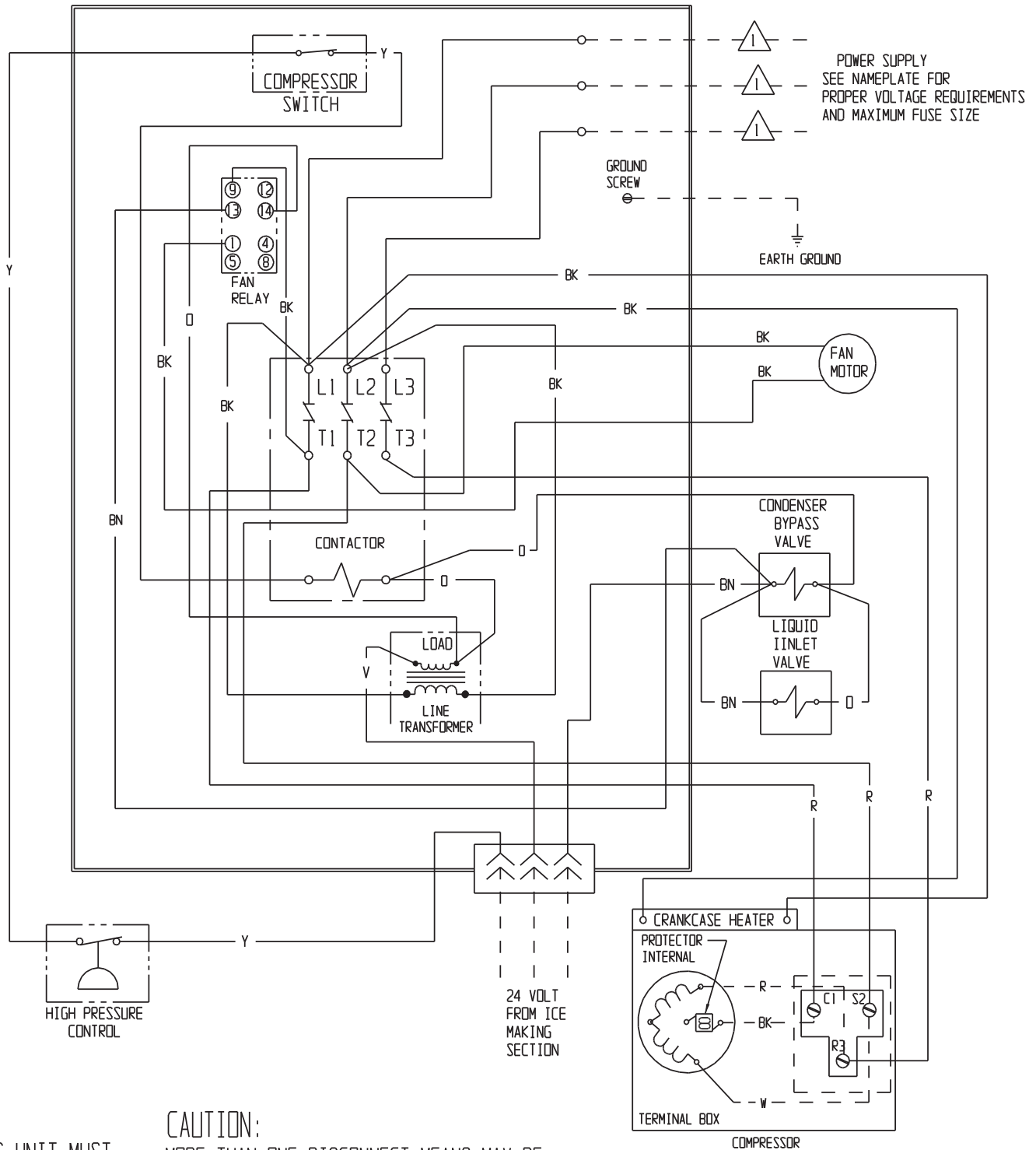

THIS UNIT MUST
BE GROUNDED.

CAUTION:
MORE THAN ONE DISCONNECT MEANS MAY BE
REQUIRED TO DISCONNECT ALL POWER TO THIS UNIT.

Prodigy Eclipse ECC, EH330 and EH430 C-E Service Parts

ECC1410 E Three Phase Schematic Diagram

⚠ DASHED LINES INDICATE FIELD WIRING WHICH MUST BE INSTALLED IN ACCORDANCE WITH THE NATIONAL ELECTRICAL CODE AND ALL STATE AND LOCAL CODES.

