

CM500 SERVICE PARTS

This section contains the parts illustrations and parts lists for the CM500.

A "no number" designation, when found in the part number column, indicates the part in question is not available from Scotsman as an assembly. This designation is used only for clarity in making the list.

When ordering parts, to avoid costly delays and errors, give the part number, the complete description as shown in the list, and the quantity of each part or assembly required.

CM500's have been manufactured in "C", "D" and "E" series (as in CM500AE-1E).

Check the complete model number to match up with the correct part number in this list.

"E" series production began in June 1992. Major differences between the "D" and the "E" are the compressor and related starting components.

TABLE OF CONTENTS

Exterior Panels	2
Interior Panels	3
Air Cooled Refrigeration	4
Water Cooled Refrigeration	5
Water System	6
Control Box	7
Wiring Diagrams	8

CM500 SERVICE PARTS

CABINET ASSEMBLY: D and E series, C series parts are obsolete.

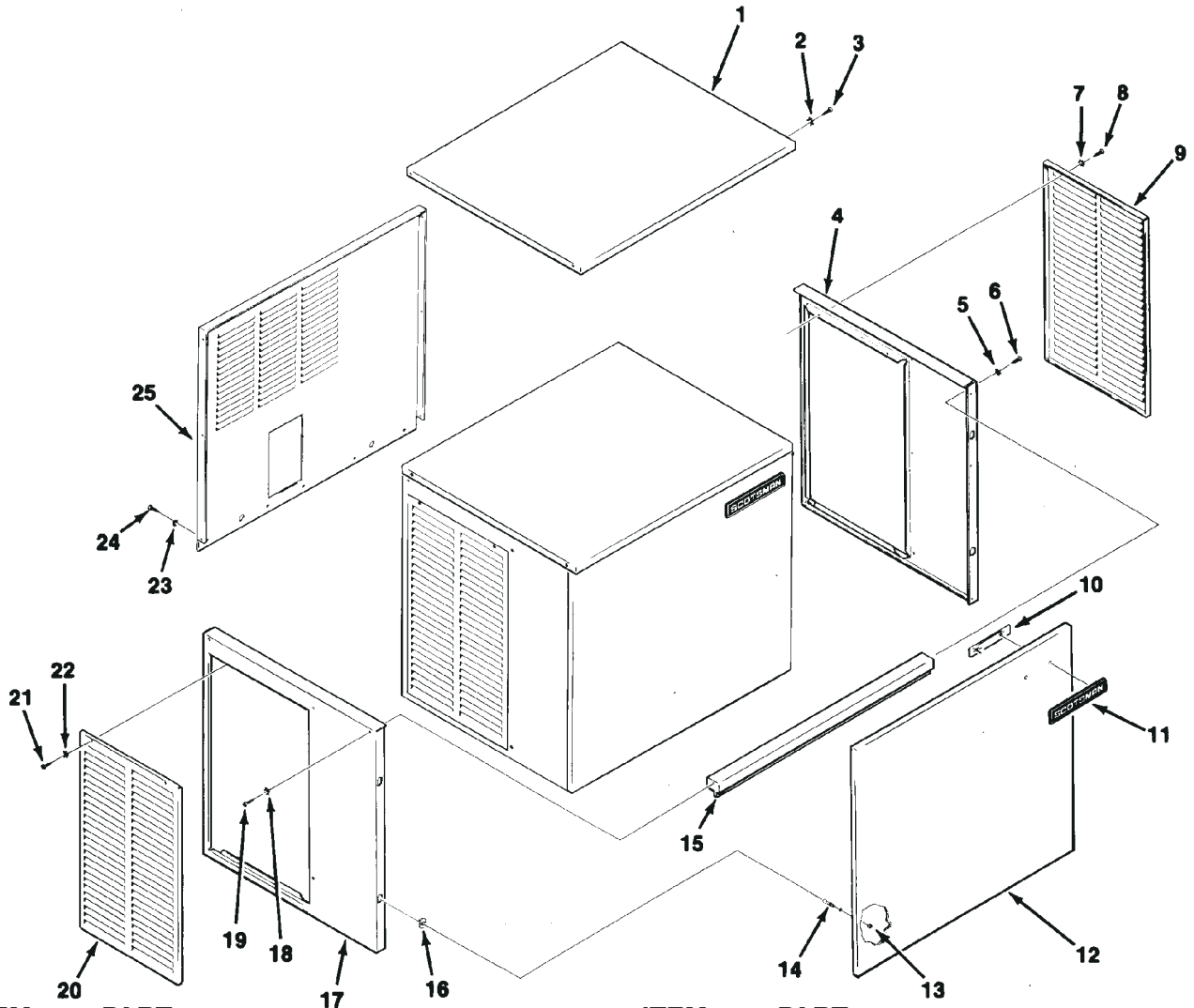

ITEM NUMBER	PART NUMBER	DESCRIPTION	ITEM NUMBER	PART NUMBER	DESCRIPTION
1	A32159-001	Top Panel, Painted	13	03-1406-04	Nut
	A32159-002	Top Panel, S. S.	14	15-0411-00	Strike
2	03-1417-03	Lockwasher	15	A32169-001	Front Support
3	03-1531-01	Screw	16	02-0836-00	Cabinet Catch
4	A32162-001	Right End Panel, Paint	17	A32163-001	Left End Panel, Paint
	A32162-002	Right End Panel, S.S.		A32163-002	Left End Panel, S.S.
5	03-1417-03	Lockwasher	18	03-1417-03	Lockwasher
6	03-1531-01	Screw	19	03-1531-01	Screw
7	03-1417-03	Lockwasher	20	A32161-001	Service Panel, sandalwood
8	03-1404-12	Screw		A33946-002	Service Panel, gray
9	A32161-001	Service Panel, Painted	Item 20 parts are plastic, fit late D and all E series		
	A32161-002	Service Panel, S.S.	21	03-1404-12	Screw
10	03-0271-00	Speed Nut	22	03-1412-03	Lockwasher
11	15-0711-01	Emblem	23	03-1417-03	Lockwasher
12	A32160-001	Front Panel, Painted	24	03-1531-01	Screw
	A32160-002	Front Panel, S.S.	25	A32202-003	Back Panel

CM500 SERVICE PARTS

CABINET INTERIOR: D and E series, C series parts are obsolete.

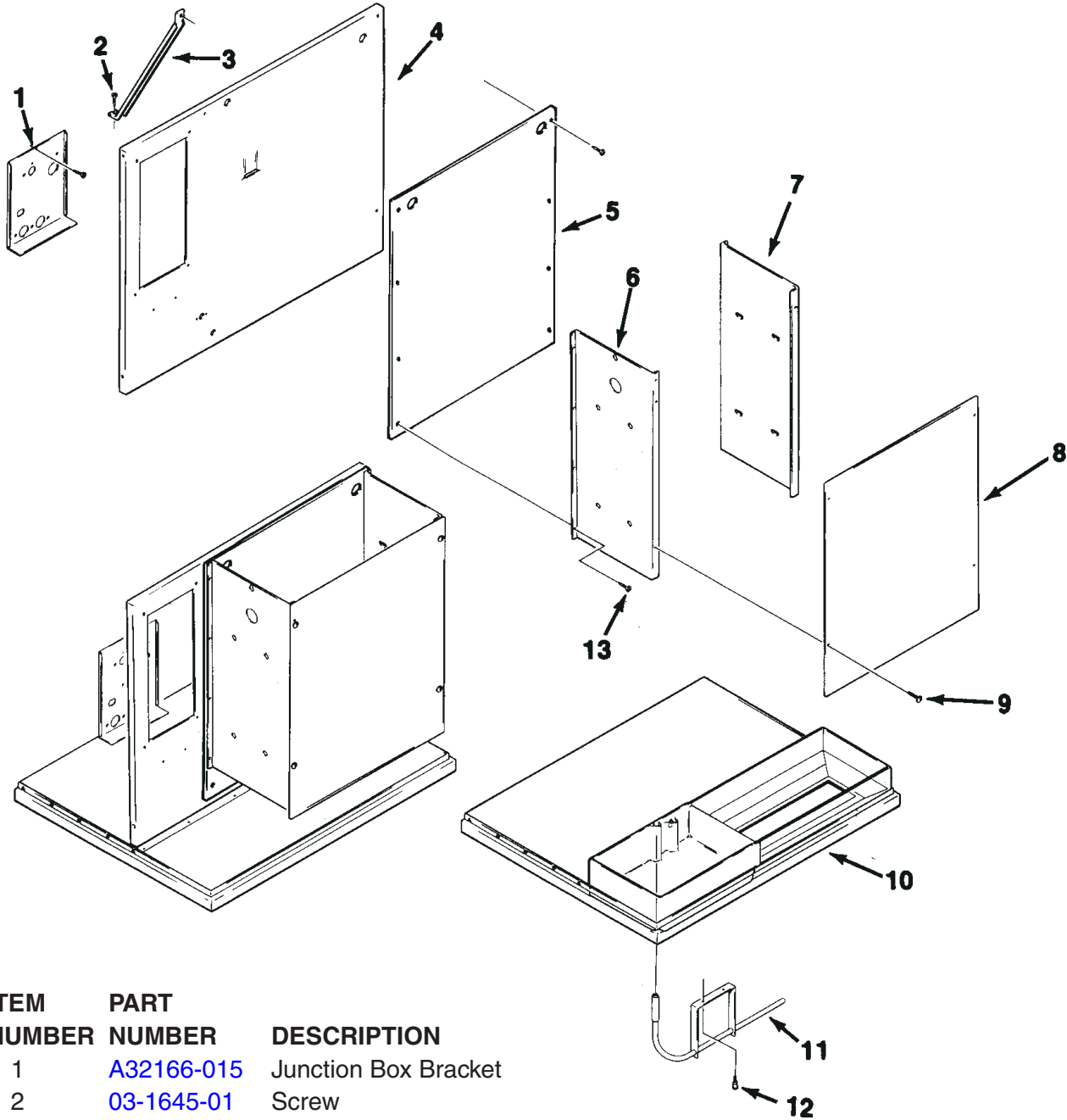

ITEM NUMBER	PART NUMBER	DESCRIPTION
1	A32166-015	Junction Box Bracket
2	03-1645-01	Screw
3	A32210-001	Support Brace
4	A32158-001	Retainer
5	02-2867-01	Splash Panel
6	A32173-001	Evaporator Bracket, left
7	A32172-001	Evaporator Bracket, right
8	02-3246-01	Evaporator Plate Cover
9	03-0727-09	Thumbscrew
10	A32153-001	Base
11	A32262-001	Bin Thermostat Bracket
12	03-0727-09	Thumbscrew
13	03-1531-02	Screw

CM500 SERVICE PARTS

AIR COOLED REFRIGERATION

Not Illustrated:
Hot Gas Valve Filter, use began with "E" model, part number: **02-3231-02**

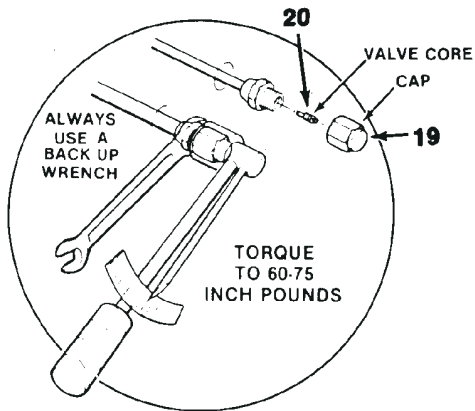

ALWAYS USE A BACK-UP WRENCH TO AVOID DAMAGE TO THE REFRIGERANT TUBING.

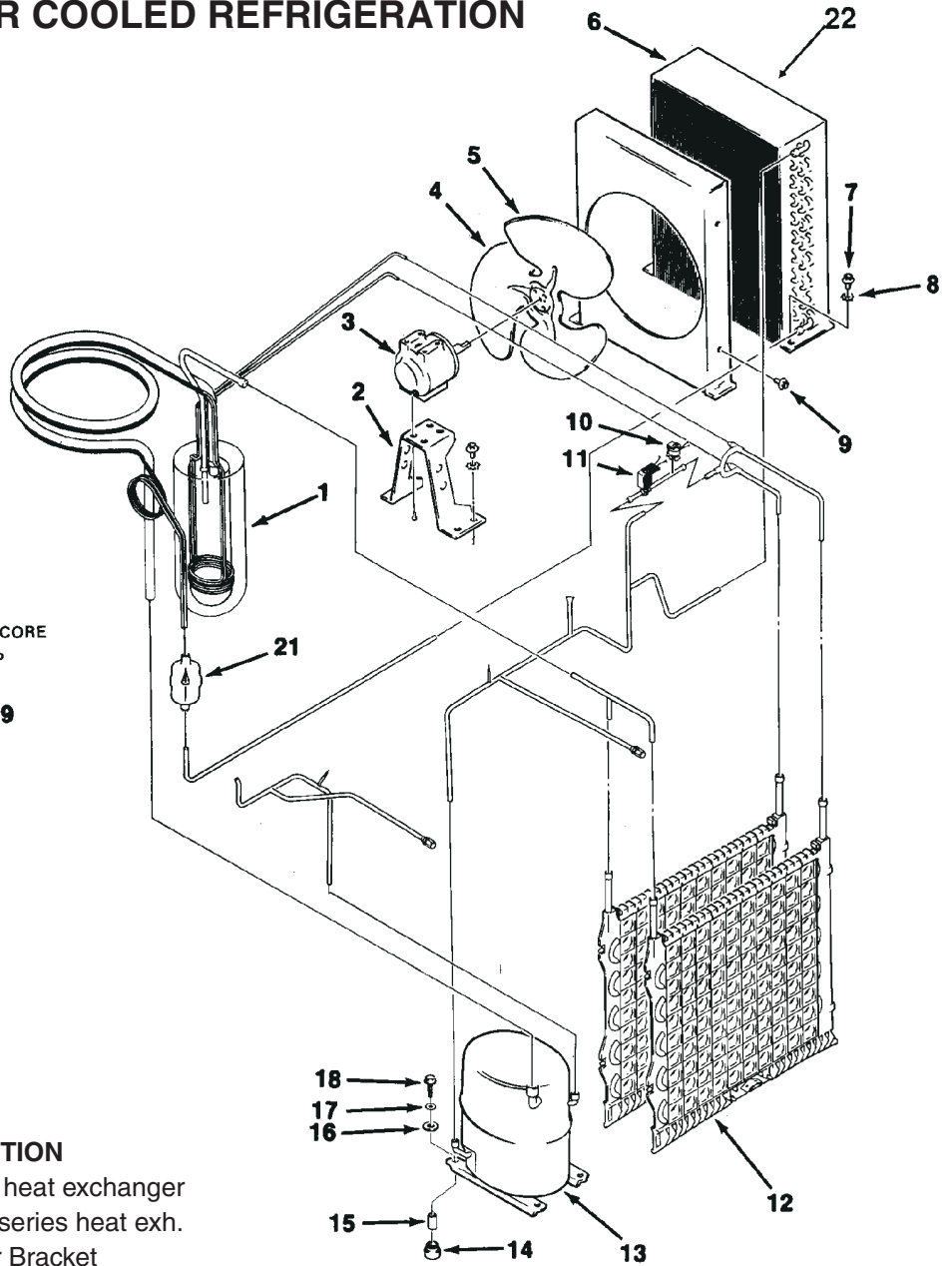

ITEM NUMBER	PART NUMBER	DESCRIPTION
1	A31525-020	"C" series heat exchanger
	A32245-020	"D" or "E" series heat exh.
2	18-3739-01	Fan Motor Bracket
3	18-5105-11	Fan Motor
4	18-3732-01	Fan Blade
5	02-2558-01	"C" series fan shroud
	A32171-001	"D" or "E" series fan shroud
6	18-0398-01	Condenser
7	03-1405-03	"C" series screw
	03-1645-01	"D" or "E" series screw
8	03-1410-03	Lockwasher
	03-1407-05	Washer
9	03-1531-01	Screw
10	12-2300-03	Hi Temp Cut Out "D" & "E"
11	12-2135-21	Hot Gas Valve
12	A30296-020	Evaporator

ITEM NUMBER	PART NUMBER	DESCRIPTION
13	18-6100-01	"C" and "D" series compressor
	18-6100-50	"C" and "D" series overload
	18-8711-20	"E" series compressor (115/60/1)
	18-8711-50	"E" series overload)
14	18-6800-01	Grommet
15	18-2300-26	Sleeve
16	03-1407-07	Washer
17	03-1407-07	Washer
18	03-1405-20	Screw
19	16-0563-00	Cap
20	16-0560-00	Core
21	02-3319-02	Drier
22	A32975-001	Foam Filter

CM500 SERVICE PARTS

WATER COOLED REFRIGERATION

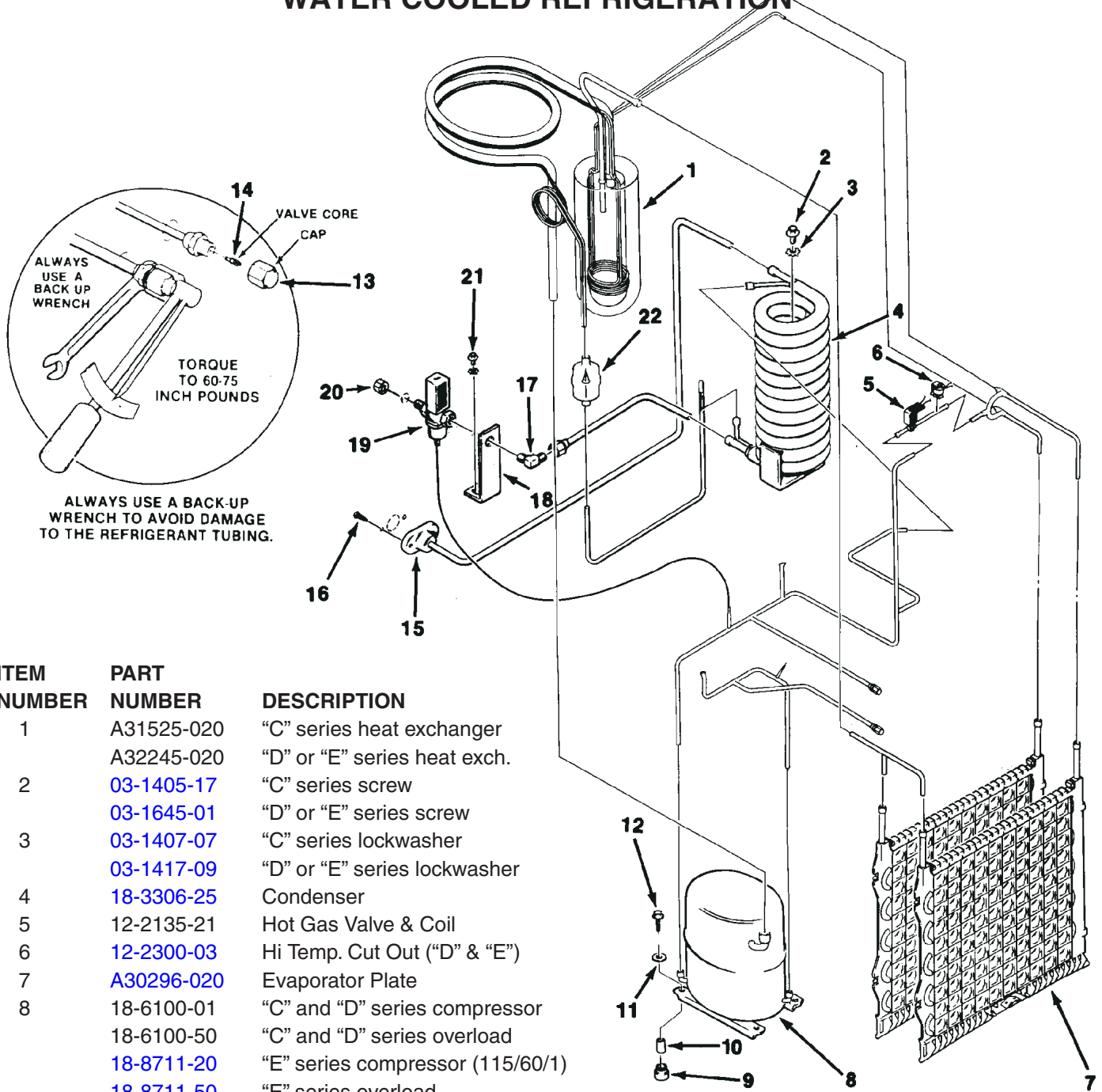

ITEM NUMBER	PART NUMBER	DESCRIPTION
1	A31525-020	"C" series heat exchanger
	A32245-020	"D" or "E" series heat exch.
2	03-1405-17	"C" series screw
	03-1645-01	"D" or "E" series screw
3	03-1407-07	"C" series lockwasher
	03-1417-09	"D" or "E" series lockwasher
4	18-3306-25	Condenser
5	12-2135-21	Hot Gas Valve & Coil
6	12-2300-03	Hi Temp. Cut Out ("D" & "E")
7	A30296-020	Evaporator Plate
8	18-6100-01	"C" and "D" series compressor
	18-6100-50	"C" and "D" series overload
	18-8711-20	"E" series compressor (115/60/1)
	18-8711-50	"E" series overload
9	18-6800-01	Mounting Grommet
10	18-2300-26	Sleeve
11	03-1407-07	Washer
12	03-1405-20	Screw
13	16-0563-00	Valve Cap
14	16-0560-00	Valve Core
15	A33363-001	Drain Fab Assembly

ITEM NUMBER	PART NUMBER	DESCRIPTION
16	03-1403-14	Screw
17	16-0401-02	Brass Elbow
18	no number	Bracket
19	11-0424-01	Water Reg. Valve
20	03-1394-01	Pal Nut
21	03-1403-14	Screw
22	02-3319-02	Filter Drier

Not Illustrated: Hot Gas Valve Filter, part number 02-3231-02 Use began with "E" series.

CM500 SERVICE PARTS

WATER SYSTEM

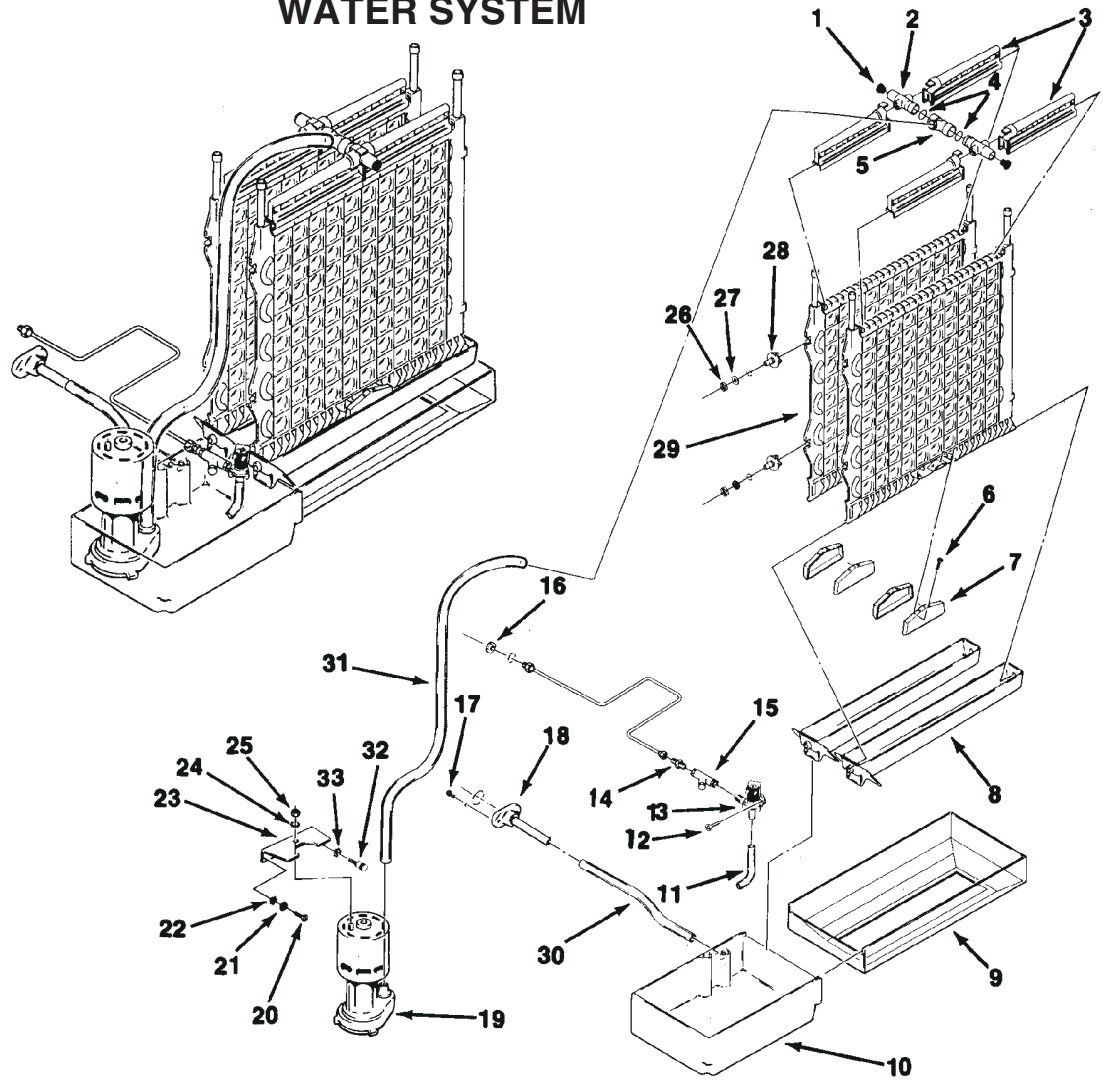

ITEM NUMBER	PART NUMBER	DESCRIPTION	ITEM NUMBER	PART NUMBER	DESCRIPTION
1	13-0840-01	Manifold Plug	17	03-1645-01	Screw
2	A29703-001	Manifold Water Tube	18	A32282-003	Drain Ass. (Air Cooled)
3	02-2527-01	Water Distrib. Tube	19	12-2265-21	Water Pump Assembly
4	13-0617-48	O-Ring (2)	20	03-1403-17	Screw
5	02-2519-01	Plastic Tee	21	03-1407-03	Washer
6	03-1404-10	Screw	22	03-1408-31	Washer
7	02-2878-01	Sump End Cover	23	A30914-002	Pump Mounting Bracket
8	02-2868-01	Drain Trough	24	03-1417-05	Lockwasher
9	no number	Cube Chute	25	03-1406-05	Nut
10	02-2812-02	Sump for "C" series	26	03-1394-03	Pal Nut
	02-2869-01	Sump for all others	27	03-1408-34	Special Washer
11	A30918-001	Sump Inlet Tube C thru early E	28	02-2642-01	Plate Mount
12	03-1531-01	Screw	29	A30296-020	Evaporator
13	12-2261-04	Solenoid valve "C" series	30	13-0674-07	Drain Hose, 8"
	12-2313-04	Solenoid valve, "D" or "E" series.	31	13-0674-07	Pump Hose, 33"
14	16-0791-01	Half Union	32	03-0727-09	Thumbscrew
15	16-0162-00	Strainer for D & early E series	33	03-1417-03	Lockwasher
16	03-1394-01	Pal Nut			

CM500 SERVICE PARTS CONTROL BOX

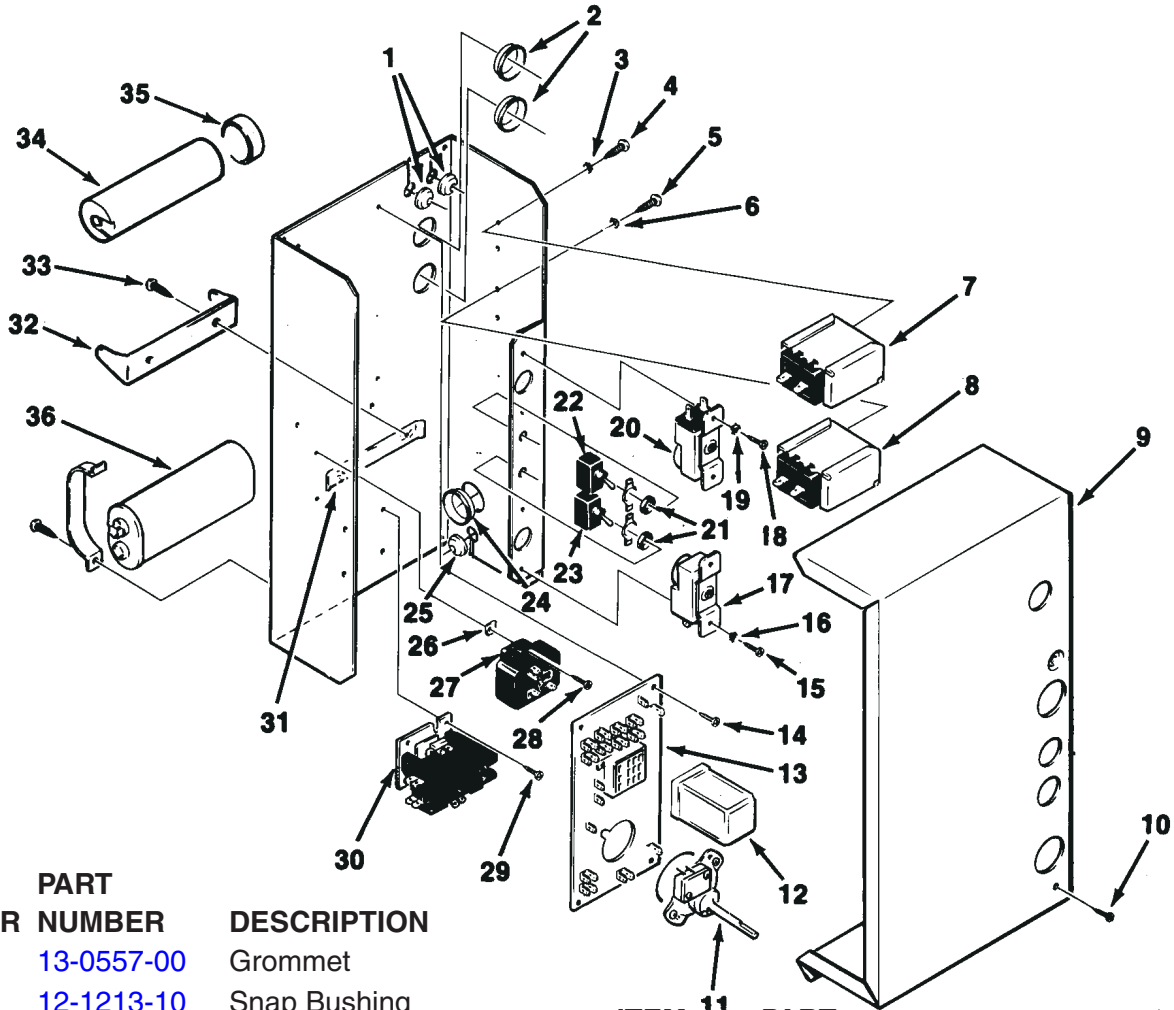

ITEM NUMBER	PART NUMBER	DESCRIPTION
1	13-0557-00	Grommet
2	12-1213-10	Snap Bushing
3	03-1417-18	Lockwasher
4	03-1403-02	Screw
5	03-1403-02	Screw
6	03-1417-18	Lockwasher
7	11-0426-22	Fan Control
8	11-0425-21	High Press. Safety -AC
	11-0410-22	High Press. Safety -WC
9	A32168-001	Control Box Cover
10	03-1531-01	Screw
11	12-1980-21	Timer & Switch
12	12-1879-02	Relay, 115 V
13	12-1912-01	Circuit Board
14	03-1403-02	Screw
15	03-1403-05	Screw
16	03-1417-03	Lockwasher
17	11-0427-22	Bin Thermostat
18	03-1403-05	Screw
19	03-1417-03	Lockwasher
20	11-0435-21	Cube Size Control

ITEM NUMBER	PART NUMBER	DESCRIPTION
21	03-1417-16	Lockwasher
22	12-0426-01	Switch
23	12-0426-01	Switch
24	12-1213-17	Snap Bushing
25	13-0557-00	Grommet
26	03-1423-01	Speed Nut
27	18-1903-44	Potential Relay "C" & "D"
	18-1903-50	Potential Relay, "E" series
28	03-1403-02	Screw
29	03-1403-15	Screw
30	12-2469-03	Contactor,
31	no number	Twin Speed Nut
32	18-2200-39	Start Capacitor Bracket
33	03-1403-15	Screw
34	18-1901-42	Start Capacitor "C" & "D"
	18-1901-03	Start capacitor, "E" series
35	18-2200-38	Start Capacitor Cap.
36	18-1902-45	Run Capacitor "E" series only

A32045-001

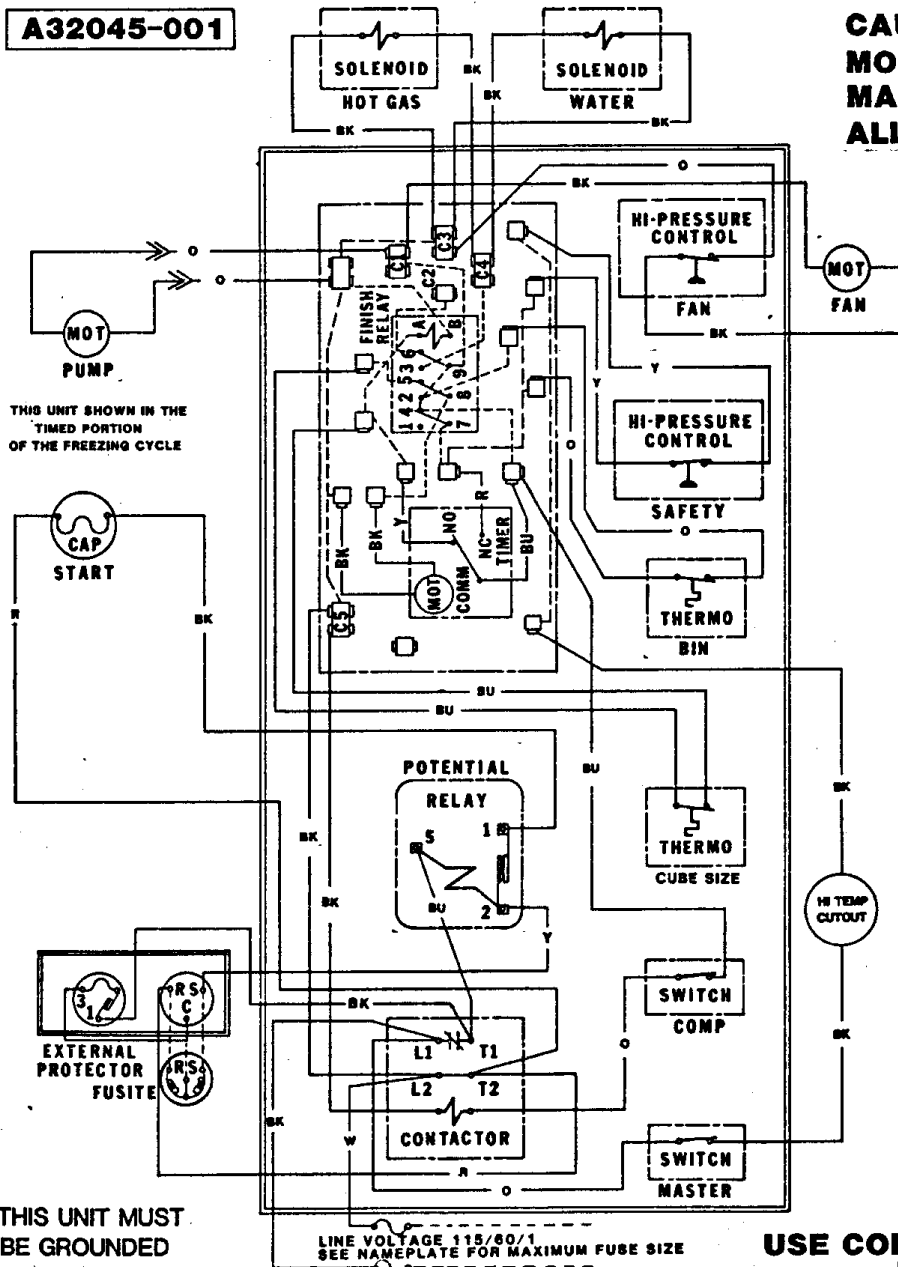

THIS UNIT SHOWN IN THE TIMED PORTION OF THE FREEZING CYCLE

THIS UNIT MUST BE GROUNDED

LINE VOLTAGE 115/60/1
SEE NAMEPLATE FOR MAXIMUM FUSE SIZE

CAUTION:
MORE THAN ONE DISCONNECT MEANS
MAY BE REQUIRED TO DISCONNECT
ALL POWER TO THIS UNIT.

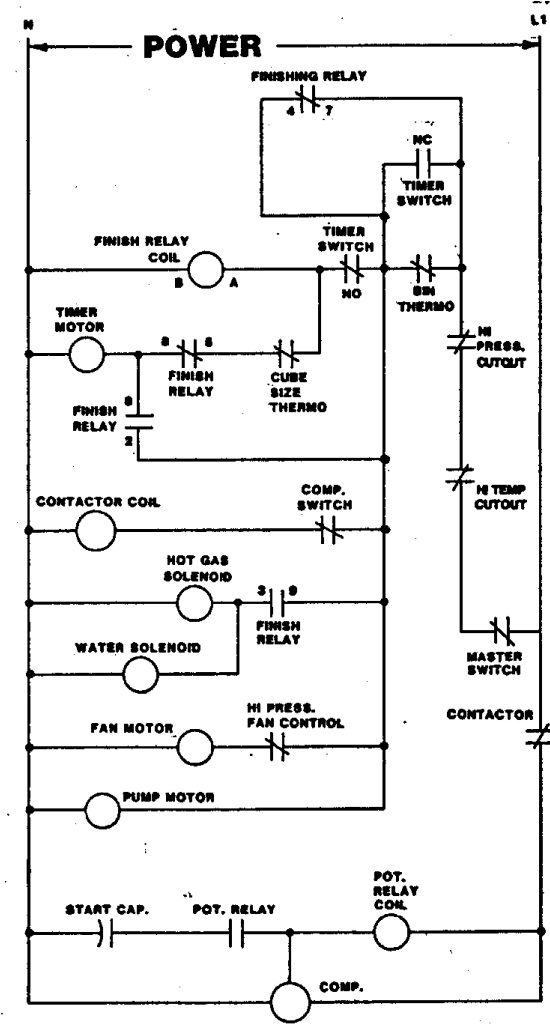

USE COPPER CONDUCTORS ONLY

Wiring Diagram CM500AE-1C (115/60/1) Air - Cooled
Use of the High Temperature Cut Out begins with serial number 872530-01G

A32046-001

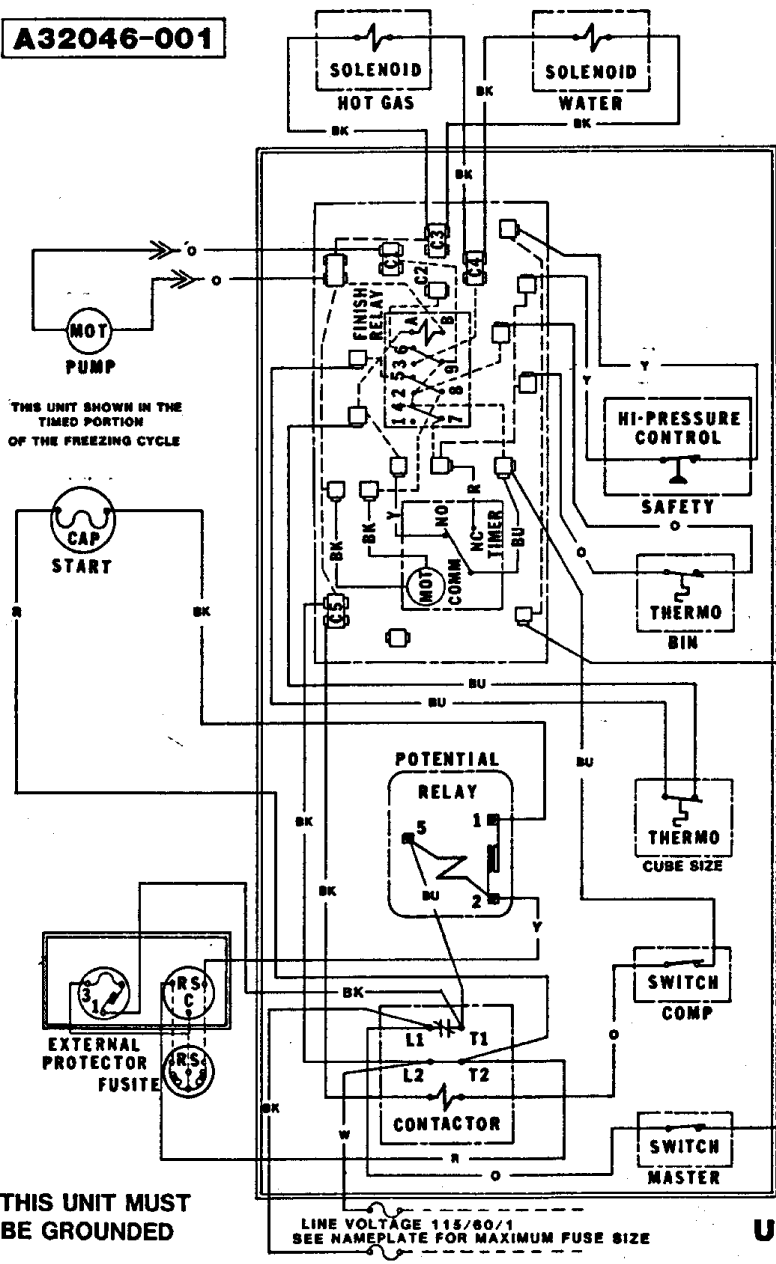

THIS UNIT MUST BE GROUNDED

LINE VOLTAGE 115/60/1
SEE NAMEPLATE FOR MAXIMUM FUSE SIZE

USE COPPER CONDUCTORS ONLY

CAUTION:
MORE THAN ONE DISCONNECT MEANS
MAY BE REQUIRED TO DISCONNECT
ALL POWER TO THIS UNIT.

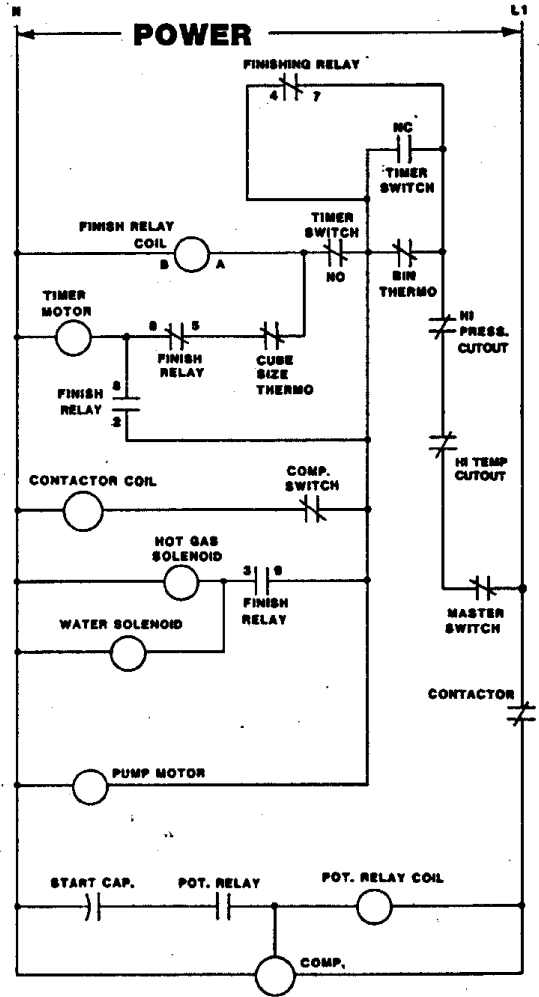

CM500 SERVICE PARTS

Wiring Diagram CM500AW-1C (115/60/1) Water-Cooled
Use of the High Temperature Cut Out begins with serial number 872530-01G

A32248-001

**CAUTION:
MORE THAN ONE DISCONNECT MEANS
MAY BE REQUIRED TO DISCONNECT
ALL POWER TO THIS UNIT.**

Wiring Diagram CM500AE-1D Air Cooled

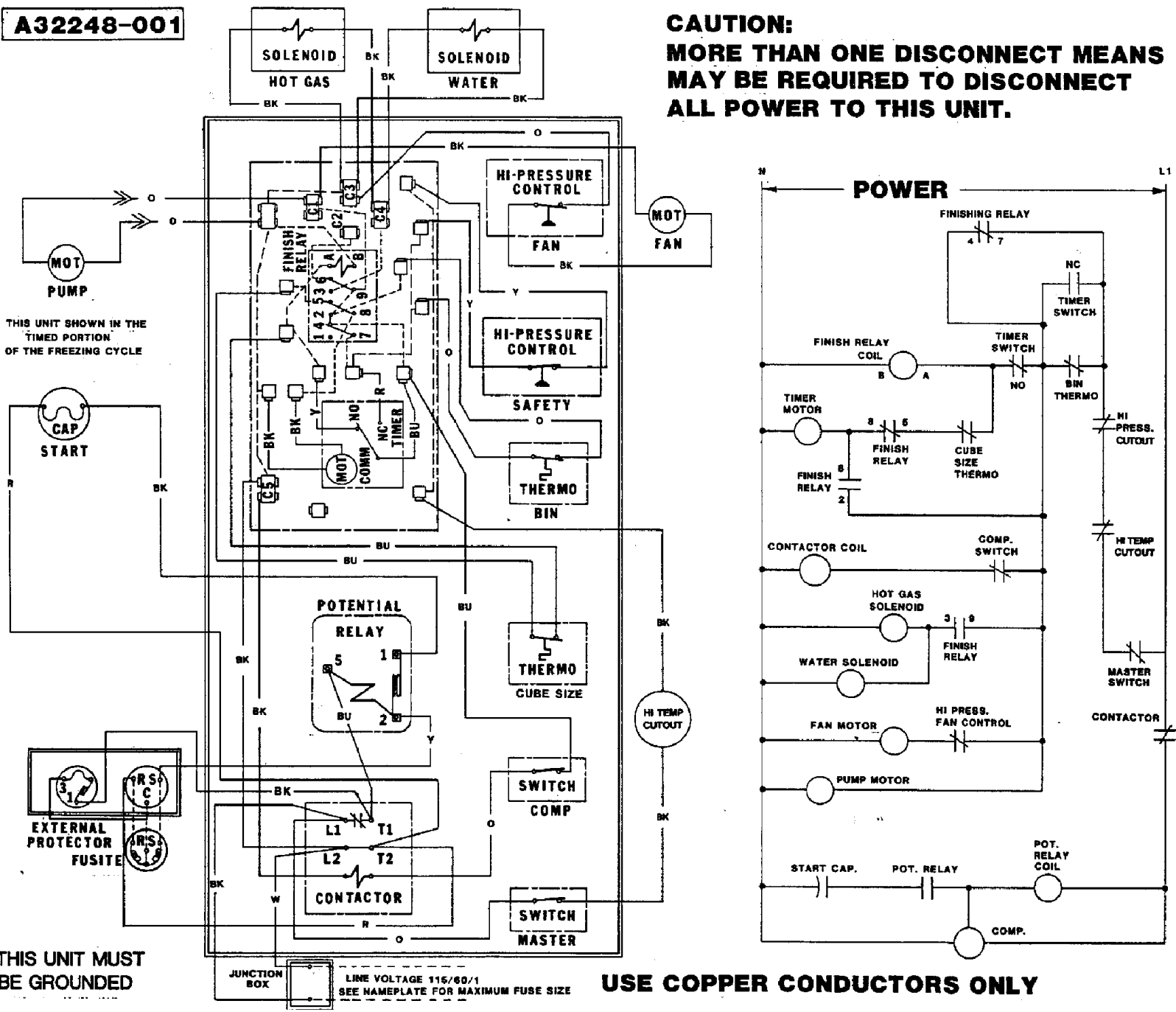

THIS UNIT SHOWN IN THE
TIMED PORTION OF
THE FREEZING CYCLE

**THIS UNIT MUST
BE GROUNDED**

JUNCTION BOX
LINE VOLTAGE 115/60/1
SEE NAMEPLATE FOR MAXIMUM FUSE SIZE

USE COPPER CONDUCTORS ONLY

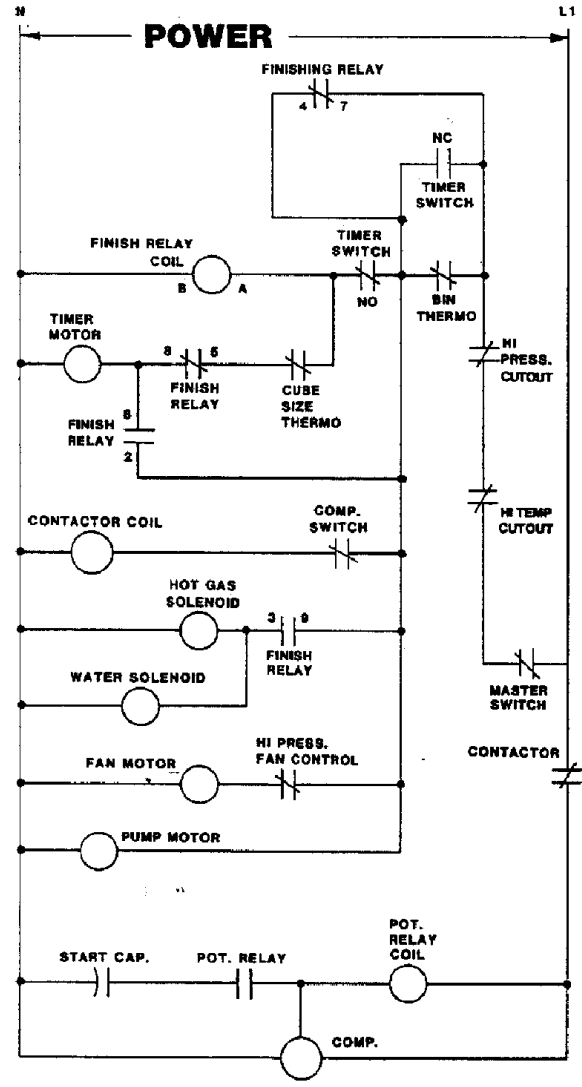

CM500 SERVICE PARTS

A32249-001

Wiring Diagram CM500WE-1D Water Cooled

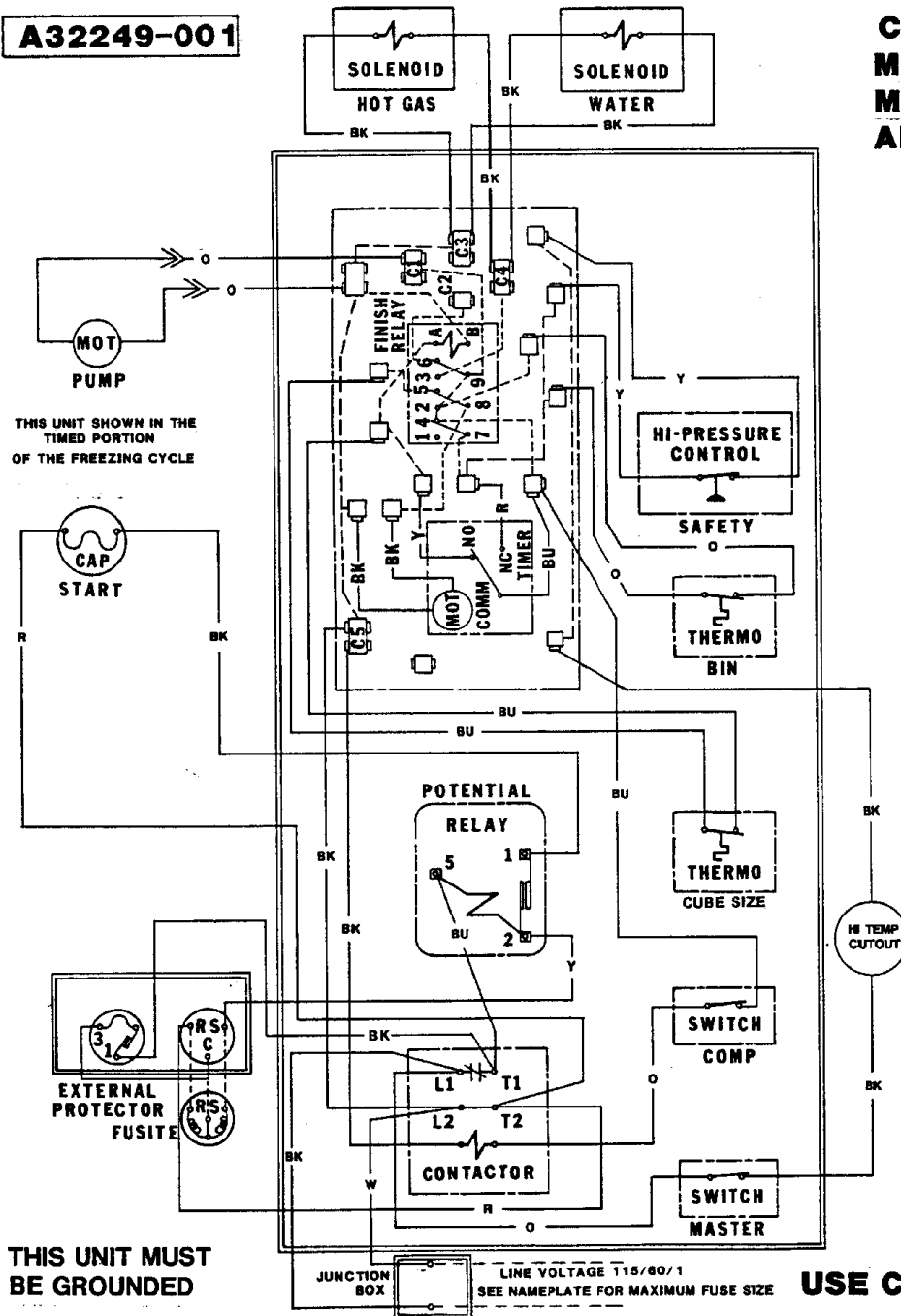

THIS UNIT MUST BE GROUNDED



LINE VOLTAGE 115/60/1
SEE NAMEPLATE FOR MAXIMUM FUSE SIZE

**CAUTION:
MORE THAN ONE DISCONNECT MEANS
MAY BE REQUIRED TO DISCONNECT
ALL POWER TO THIS UNIT.**

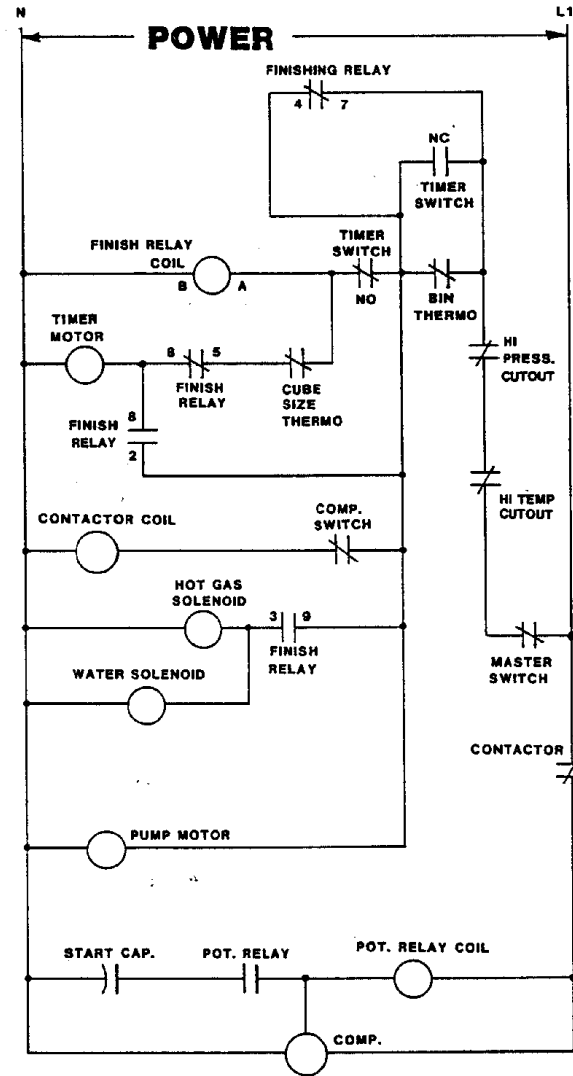

USE COPPER CONDUCTORS ONLY

CM500 SERVICE PARTS

CM500 SERVICE PARTS

"E" Series Air Cooled Wiring Diagram

A35536-001

CAUTION:
MORE THAN ONE DISCONNECT
MEANS MAY BE REQUIRED
TO DISCONNECT ALL
POWER TO THIS UNIT

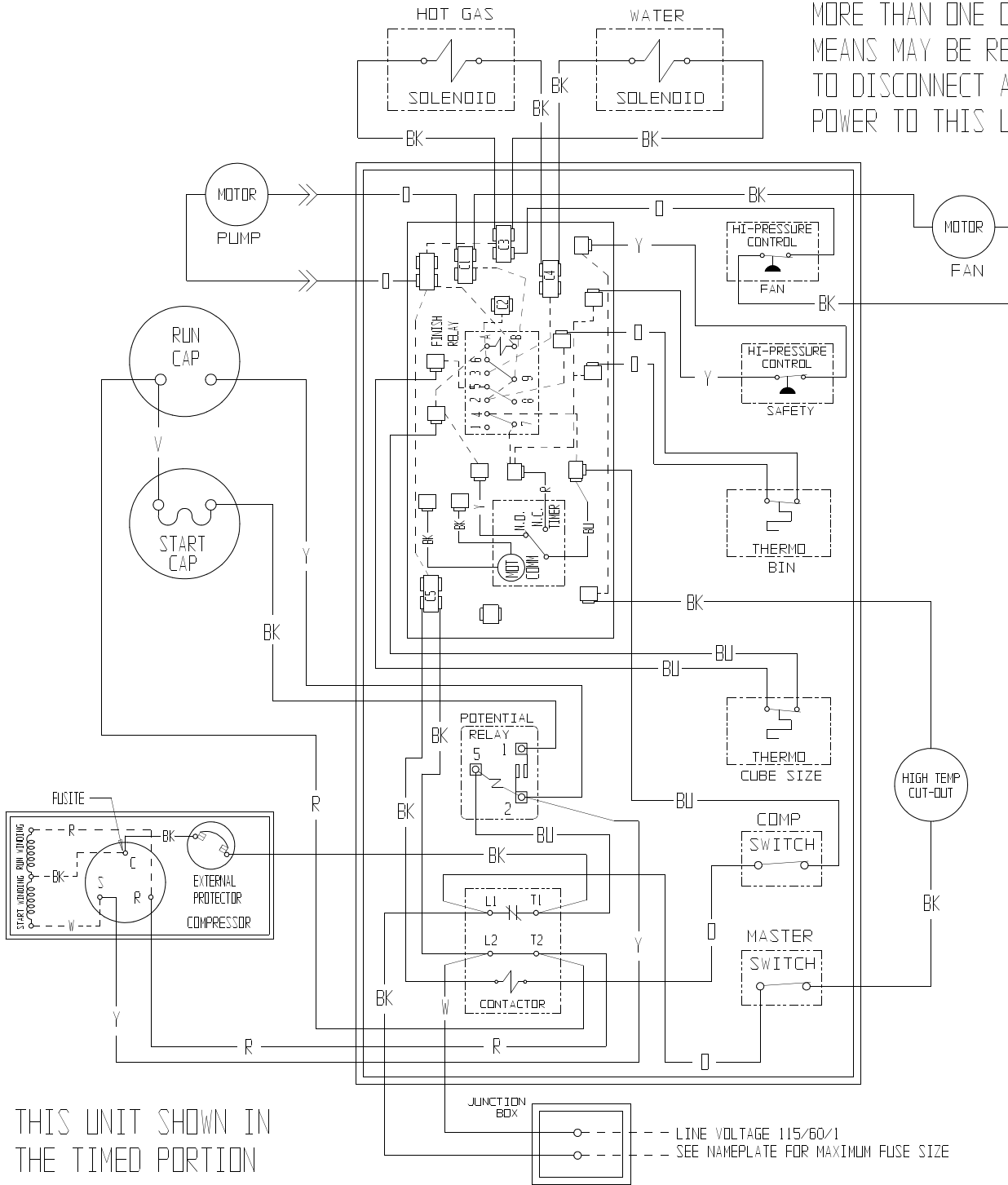

THIS UNIT SHOWN IN
THE TIMED PORTION
OF THE FREEZING CYCLE

USE COPPER CONDUCTORS ONLY

THIS UNIT MUST BE GROUNDING

CM500 SERVICE PARTS

"E" Series Air Cooled Wiring Diagram

CAUTION:
 MORE THAN ONE DISCONNECT MEANS MAY BE REQUIRED
 TO DISCONNECT ALL POWER TO THIS UNIT

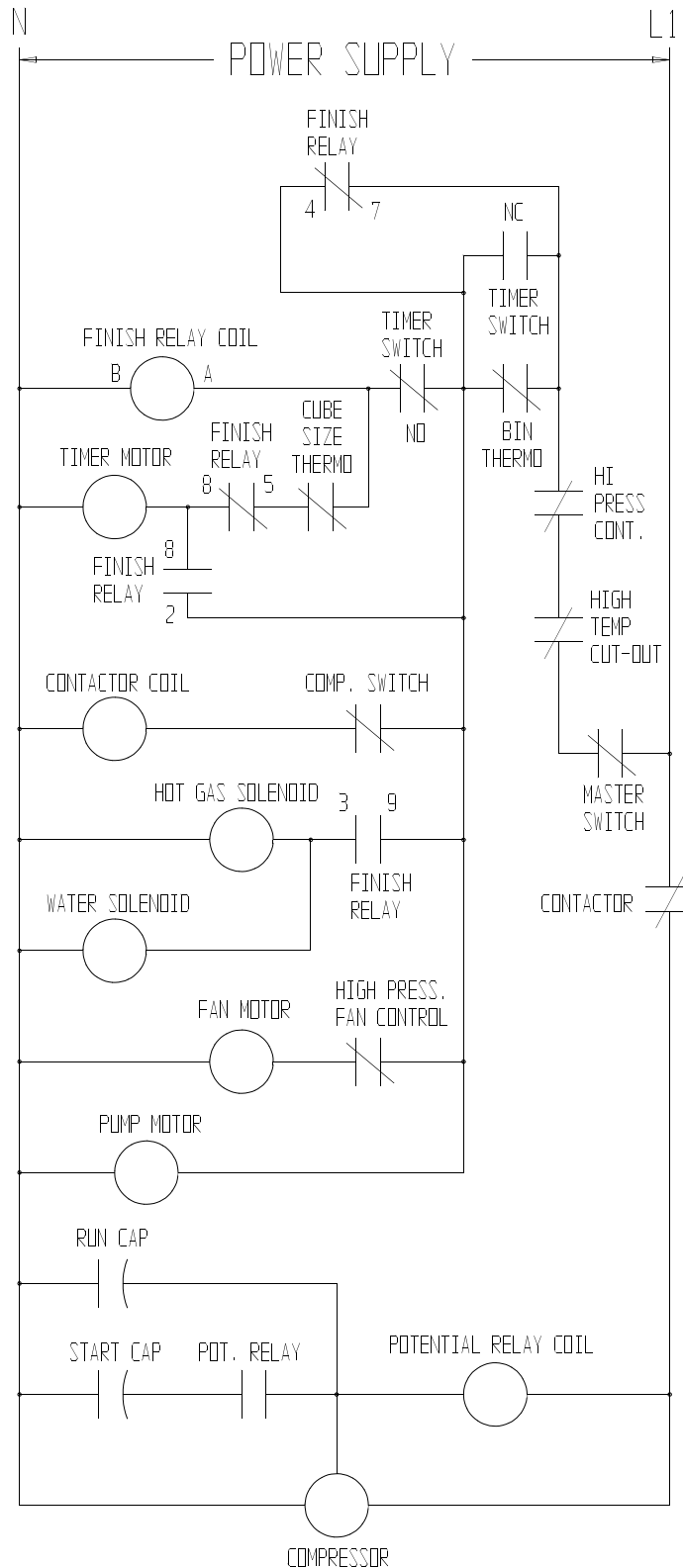

CM500 SERVICE PARTS

"E" Series Water Cooled Wiring Diagram

A35537-001

CAUTION:
MORE THAN ONE DISCONNECT
MEANS MAY BE REQUIRED
TO DISCONNECT ALL
POWER TO THIS UNIT

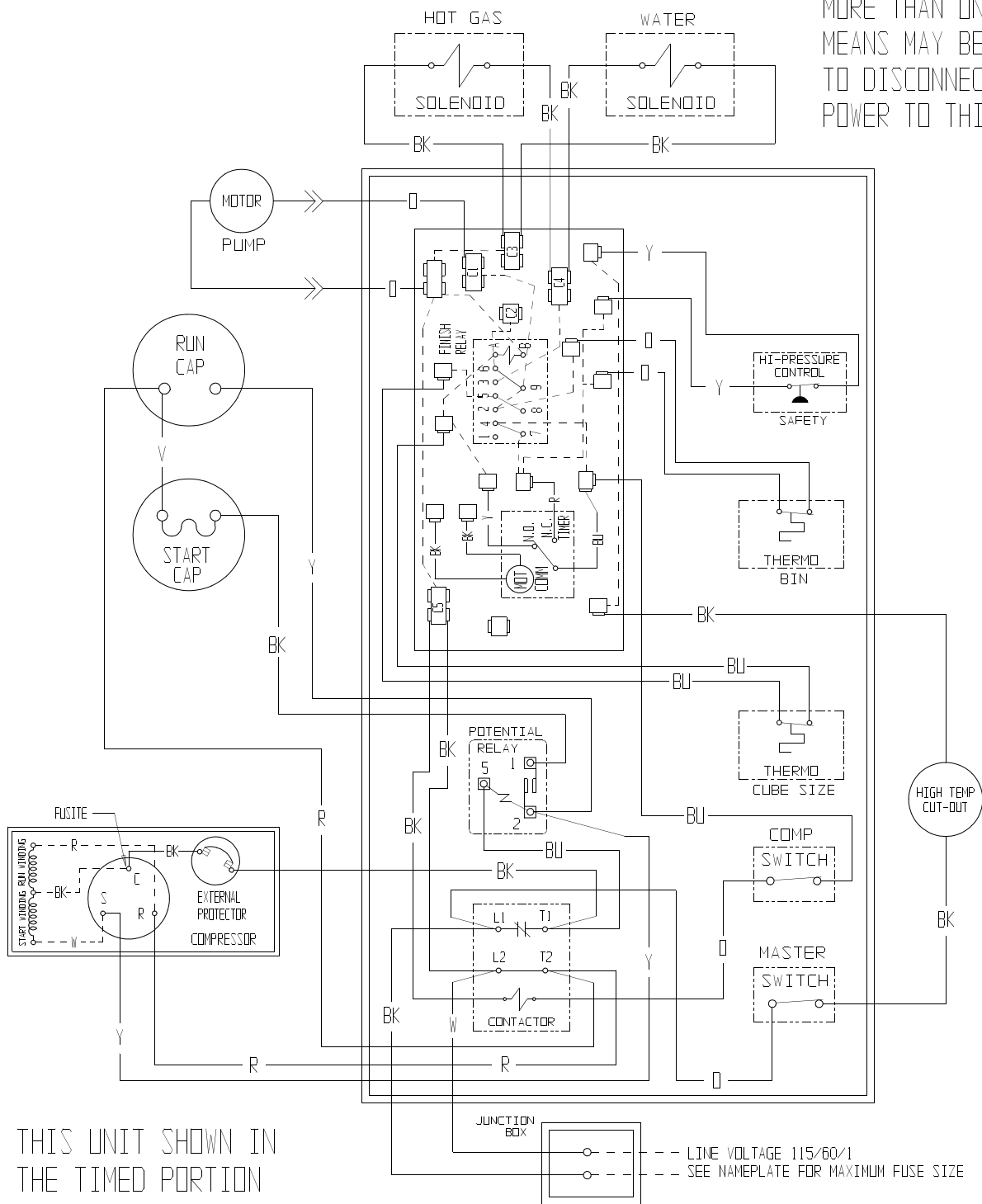

THIS UNIT SHOWN IN
THE TIMED PORTION
OF THE FREEZING CYCLE

USE COPPER CONDUCTORS ONLY THIS UNIT MUST BE GROUNDED

CM500 SERVICE PARTS

"E" Series Water Cooled Wiring Diagram

CAUTION:

MORE THAN ONE DISCONNECT MEANS MAY BE REQUIRED TO DISCONNECT ALL POWER TO THIS UNIT

