

C0330, C0530, C0630, C0830, C1030 Service Parts

Cabinet - C0330, C0530, C0630 - A Series

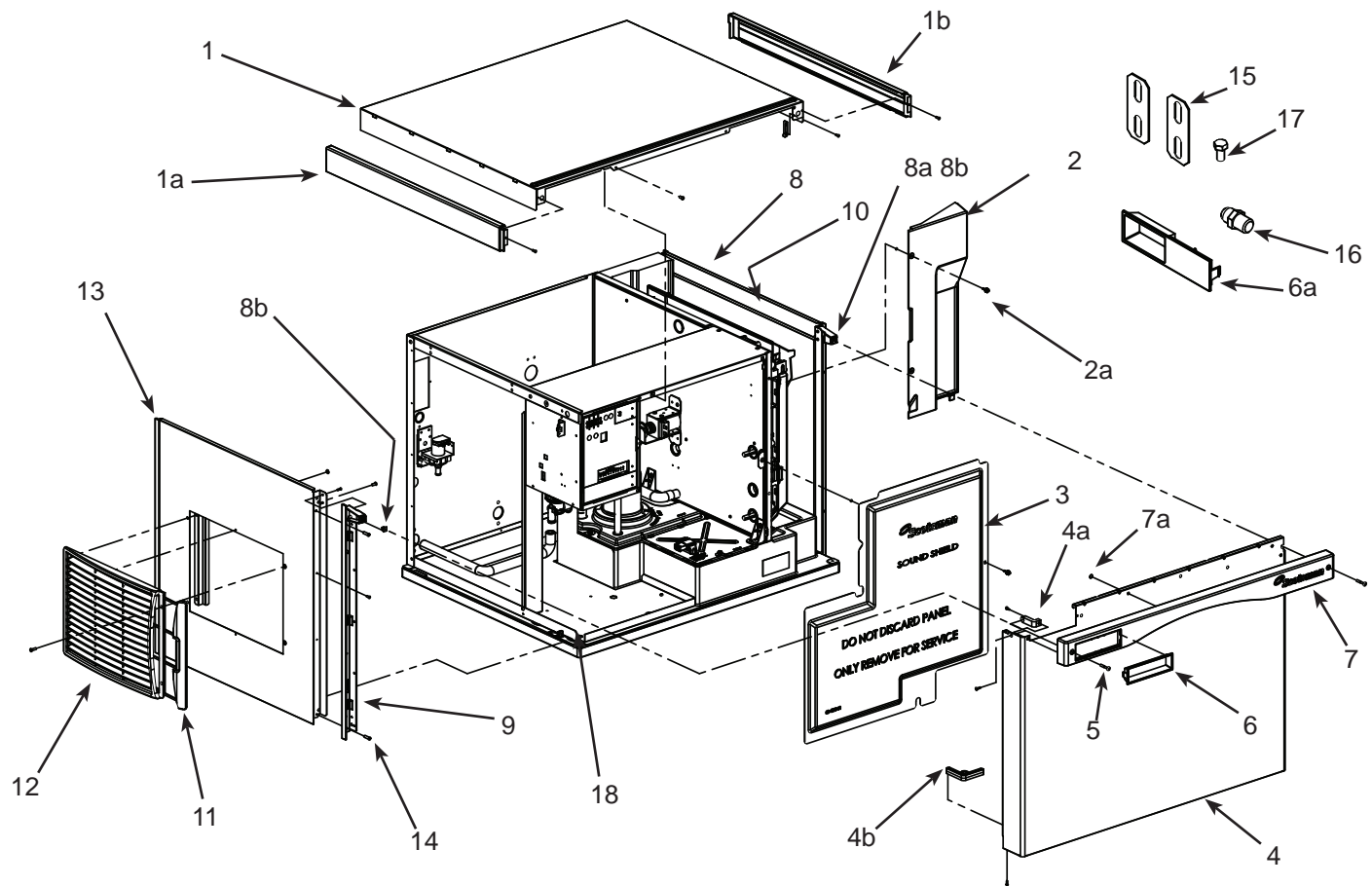

Item Number	Part Number	Description
1*	A38941-022	Top panel, w/trim strips
1a	02-4221-01	Left trim strip
1b	02-4221-02	Right trim strip
2	02-4240-01	Evaporator cover
2a	03-0727-05	Screw
3	02-4218-01	Sound shield - discontinued late 2008
4*	A38552-022	Front panel assembly, includes trim strip, gussets and labels.
4a	02-4216-01	Top gusset
4b	02-4217-01	Bottom gusset
5	03-1735-03	Screw, front panel
6	02-4284-01	Bezel, full window
6a	02-4284-02	Bezel, partial window
7	02-4214-02	Trim strip
7a	03-1731-02	Push nut
8*	A38553-021	Right side panel assy
8a	02-4215-01	Receptacle
8b	03-3804-01	Screw receptacle
9	02-4067-01	Side panel support for water cooled and remote models
	02-4067-02	Side panel support for air cooled models
10	02-4336-01	Right side panel liner
11	02-4212-01	Air filter
12	02-4224-01	Louver panel
12a	A39222-001	Filter guide
12b	A39238-001	Louver bracket
13*	A38551-021	Left side panel, AC
	A38551-022	Left side panel WC, RC
14	03-1404-12	Screw
15	A30911-015	Machine straps
16	16-0355-00	Inlet water fitting, flare
17	03-1405-15	Screw
18	A38608-001	Compressor deck

*Note: All panels supplied complete as used on unit

C0330, C0530, C0630, C0830, C1030 Service Parts

Cabinet - 0330, 0530, 0630 - B or C Series

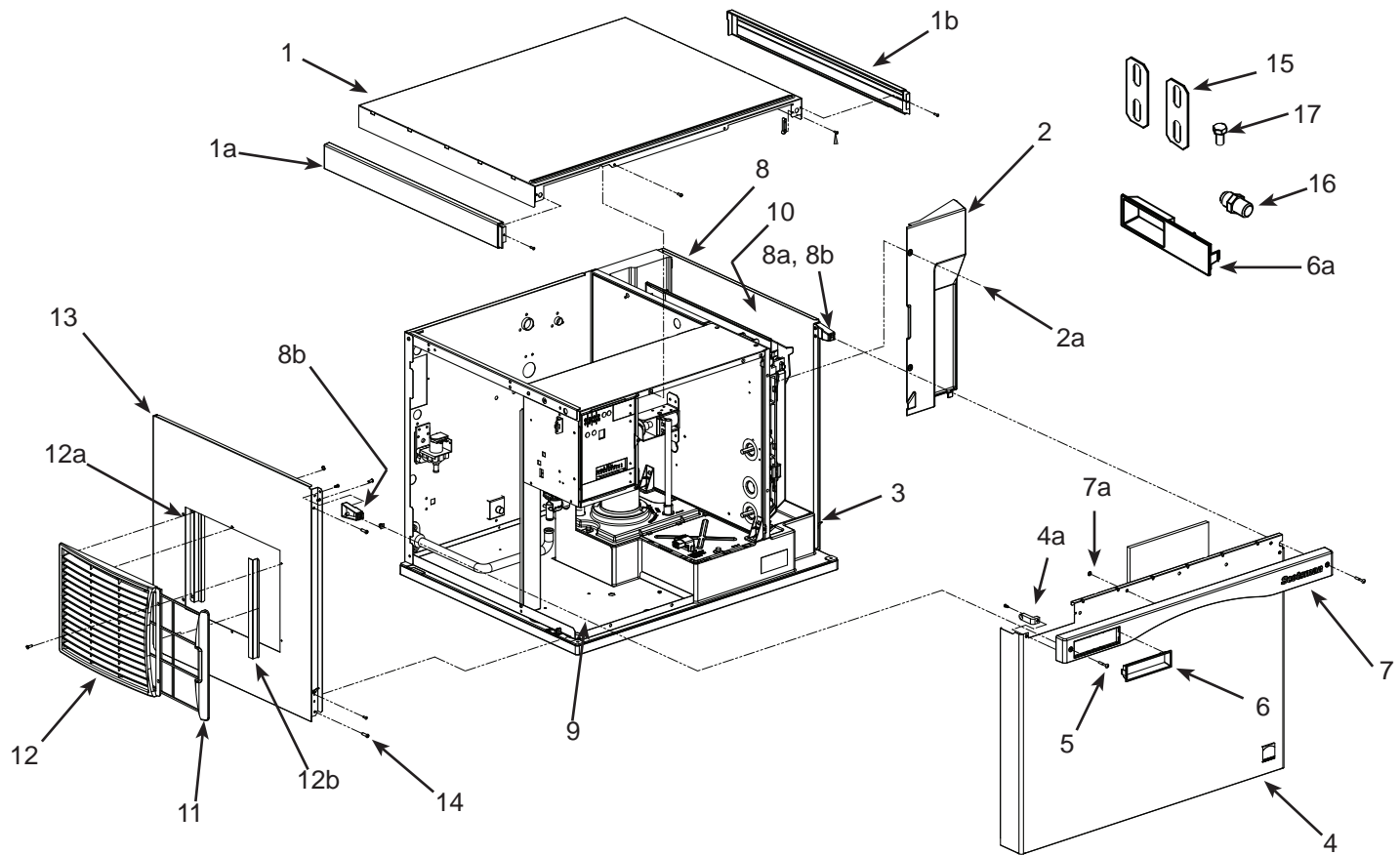

Item Number	Part Number	Description	Item Number	Part Number	Description
1	A39579-022	Top panel	8b	03-3804-01	Screw receptacle
1a	02-4221-01	Left trim strip**	9	A38608-001	Compressor deck
1b	02-4221-02	Right trim strip**	10	02-4336-01	Right side panel liner
2	02-4240-01	Evaporator cover	11	02-4212-01	Air filter
2a	03-0727-05	Screw	12	02-4224-01	Louver panel
3	A39571-001	Side panel clip	12a	A39238-001	Louver bracket
4*	A39578-022	Front panel assembly, includes trim strip and labels.	13*	A39580-021	Left side panel, AC
4a	02-4216-01	Top gusset		A39580-022	Left side panel WC, RC
5	03-1735-03	Screw, front panel	14	03-1404-12	Screw
6	02-4284-01	Bezel, full window	15	A30911-015	Machine straps
6a	02-4284-02	Bezel, partial window***	16	16-0355-00	Inlet water fitting, flare***
7	02-4214-02	Trim strip	17	03-1405-15	Screw
7a	03-1731-02	Push nut			
8*	A39581-021	Right side panel assy			
8a	02-4215-01	Receptacle			

*Note: All panels supplied complete as used on unit, except top panels do not have trim strips.

** Trim strips discontinued mid 2011

*** Bezel and fitting discontinued from production 2/8/2012.

C0330, C0530, C0630, C0830, C1030 Service Parts

Cabinet - C0330, C0530, C0630 D and E Series

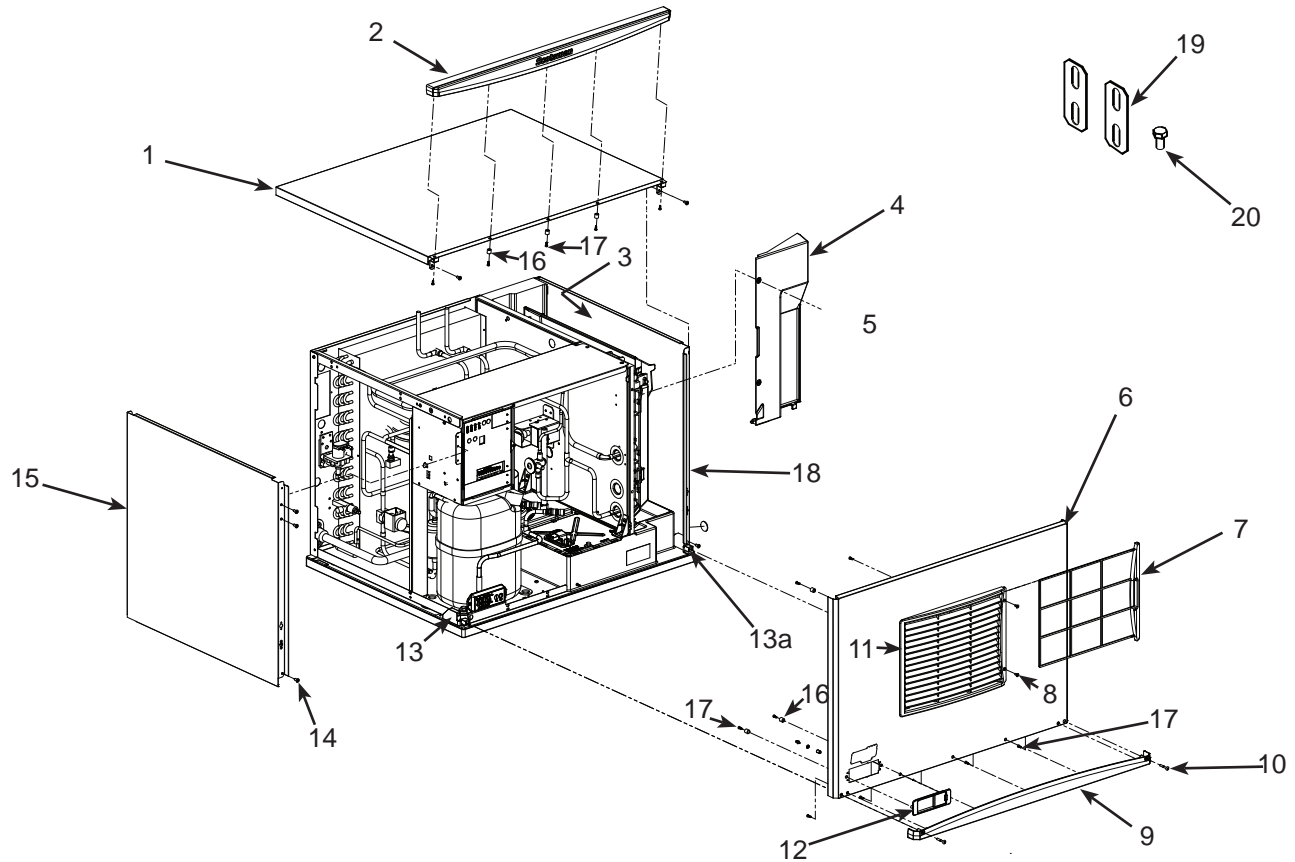

Item Number	Part Number	Description	Item Number	Part Number	Description
1	A40309-021	Top panel, includes item 2	12a	02-4822-01	Door, bezel with handle
2	02-4819-01	Trim strip	12b	02-4822-02	Door, bezel secure
3	02-4336-01	Right side liner	13	02-4823-21	*Panel mount kit, left
4	02-4240-01	Evaporator cover	13a	02-4823-22	*Panel mount kit, right
5	03-0727-05	Thumbscrew			*Includes both screw receptacles
6	A40308-021	Front panel, AC. Includes items 7, 8, 9, 10, 11, 12	14	03-1404-10	Screw
	A40308-022	Front panel, WC or RC. Includes items 9, 10, 11, 12	15	A40310-023	Left side panel, WC & RC
7	02-4212-03	Air filter		A40310-021	Left side panel, AC
8	03-1419-26	Screw	16	02-4824-01	Spacer
9	02-4820-01	Trim strip	17	03-3836-02	Screw
10	03-1735-03	Screw	18	A40311-021	Right side panel
11	02-4224-03	Louvers	19	A30911-015	Machine straps
12	02-4821-02	Bezel with standard door	20	03-1405-15	Screw

C0330, C0530, C0630, C0830, C1030 Service Parts

Cabinet - C0830, C1030 - A Series

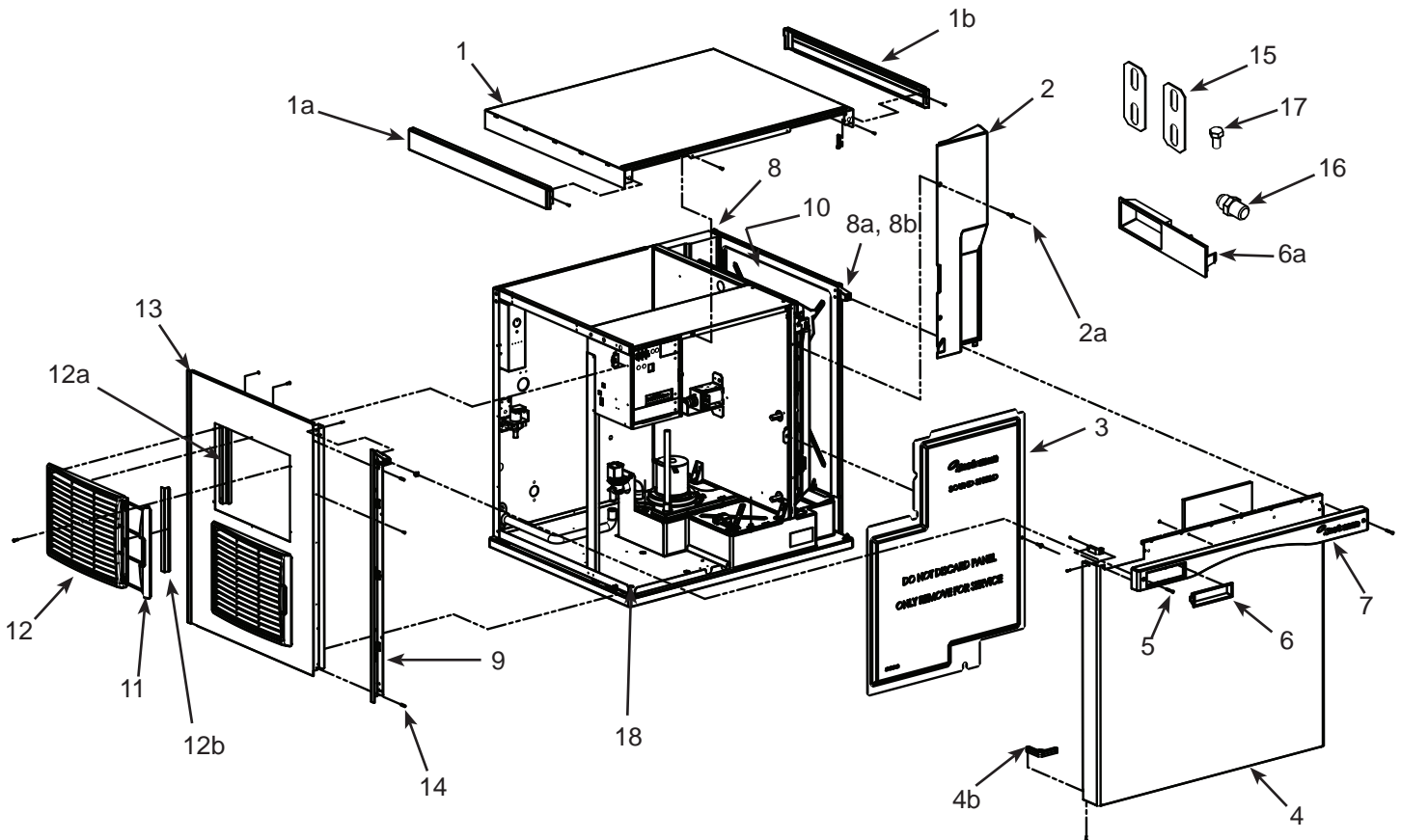

Item Number	Part Number	Description
1*	A38941-022	Top panel, w/trim strips
1a	02-4221-01	Left trim strip
1b	02-4221-02	Right trim strip
2	02-4240-02	Evaporator cover
2a	03-0727-05	Screw
3	02-4218-02	Sound shield - discontinued late 2008
4*	A38552-023	Front panel assembly, includes trim strip, gussets and labels.
4a	02-4216-01	Top gusset
4b	02-4217-01	Bottom gusset
5	03-1735-03	Screw, front panel
6	02-4284-01	Bezel, full window
6a	02-4284-02	Bezel, partial window
7	02-4214-02	Trim strip (no spacers needed)
8*	A38553-022	Right side panel assy
8a	02-4215-01	Receptacle
8b	03-3804-01	Screw receptacle
9	02-4067-03	Side panel support for water cooled and remote models
	02-4067-04	Side panel support for air cooled models
10	02-4336-02	Right side panel liner
11	02-4212-01	Air filter
12	02-4224-01	Louver panel
12a	A39222-001	Filter guide
12b	A39238-001	Louver bracket
13*	A38551-023	Left side panel, AC
	A38551-024	Left side panel WC, RC
14	03-1404-12	Screw
15	A30911-015	Machine straps
16	16-0355-00	Inlet water fitting, flare
17	03-1405-15	Screw
18	A38611-001	Compressor deck

*Note: All panels supplied complete as used on unit.

C0330, C0530, C0630, C0830, C1030 Service Parts

Cabinet - C0830, C1030 - B Series

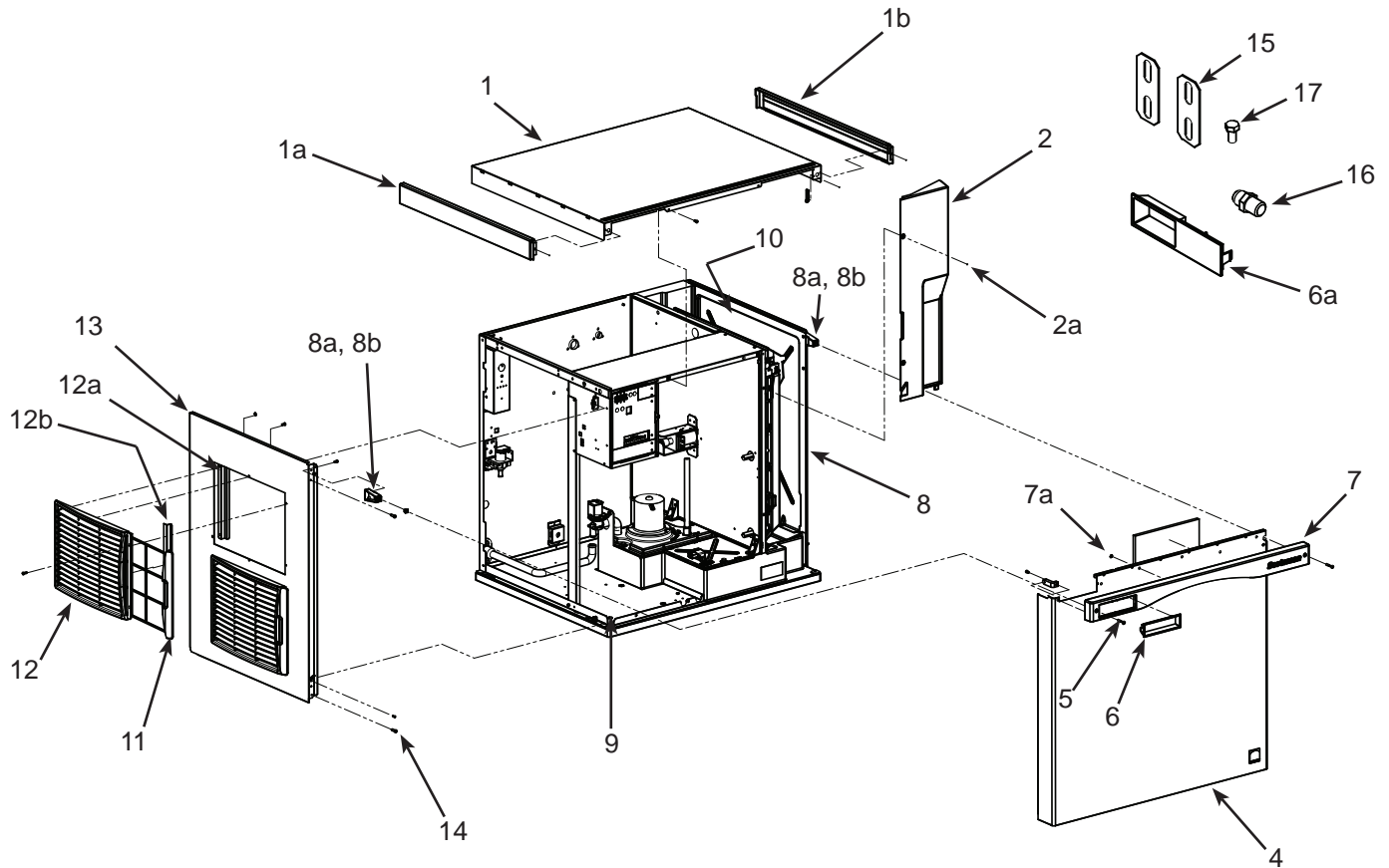

Item Number	Part Number	Description	Item Number	Part Number	Description
1	A39579-022	Top panel	8b	03-3804-01	Screw receptacle
1a	02-4221-01	Left trim strip**	9	A38611-001	Compressor deck
1b	02-4221-02	Right trim strip**	10	02-4336-02	Right side panel liner
2	02-4240-02	Evaporator cover	11	02-4212-01	Air filter
2a	03-0727-05	Screw	12	02-4224-01	Louver panel
3	A39571-001	Side panel clip	12a	A39238-001	Louver bracket
4*	A39578-023	Front panel assembly, includes trim strip and labels.	13*	A39580-023	Left side panel, AC
4a	02-4216-01	Top gusset		A39580-024	Left side panel WC, RC
5	03-1735-03	Screw, front panel	14	03-1404-12	Screw
6	02-4284-01	Bezel, full window	15	A30911-015	Machine straps
6a	02-4284-02	Bezel, partial window***	16 1	6-0355-00	Inlet water fitting, flare***
7	02-4214-02	Trim strip	17	03-1405-15	Screw
	03-1731-02	Push nut			
8*	A39581-022	Right side panel assy			
8a	02-4215-01	Receptacle			

*Note: All panels supplied complete as used on unit, except top panels do not have trim strips.

** Trim strips discontinued mid 2011

*** Bezel and fitting discontinued from production 2/8/2012.

C0330, C0530, C0630, C0830, C1030 Service Parts

Cabinet - C0830, C1030 D and E Series

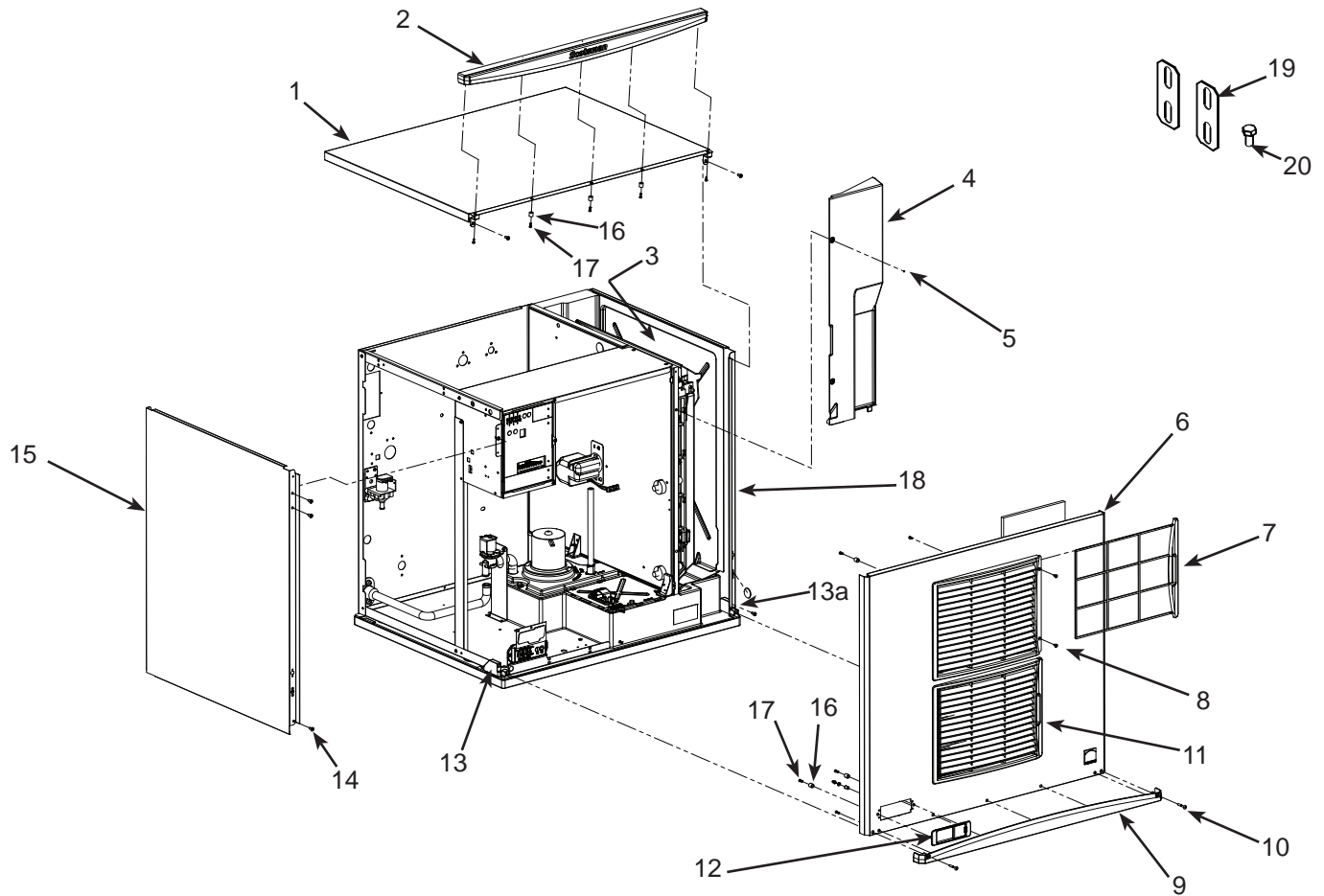

Item Number	Part Number	Description
1	A40309-021	Top panel, includes item 2
2	02-4819-01	Trim strip
3	02-4336-02	Right side liner
4	02-4240-02	Evaporator cover
5	03-0727-05	Thumbscrew
6	A40308-023	Front panel, AC. Includes items 7, 8, 9, 10, 11, 12
	A40308-024	Front panel, WC or RC. Includes items 9, 10, 12
7	02-4212-03	Air filter
8	03-1419-26	Screw
9	02-4820-01	Trim strip
10	03-1735-03	Screw
11	02-4224-03	Louvers
12	02-4821-02	Bezel with standard door
12a	02-4822-02	Door, bezel secure
13	02-4823-21	*Panel mount kit, left
13a	02-4823-22	*Panel mount kit, right
		*Includes both screw receptacles
14	03-1404-10	Screw
15	A40310-024	Left side panel, AC
	A40310-022	Left side panel, WC & RC
16	02-4824-01	Spacer
17	03-3836-02	Screw
18	A40311-022	Right side panel
19	A30911-015	Machine straps
20	03-1405-15	Screw

C0330, C0530, C0630, C0830, C1030 Service Parts

Interior Parts

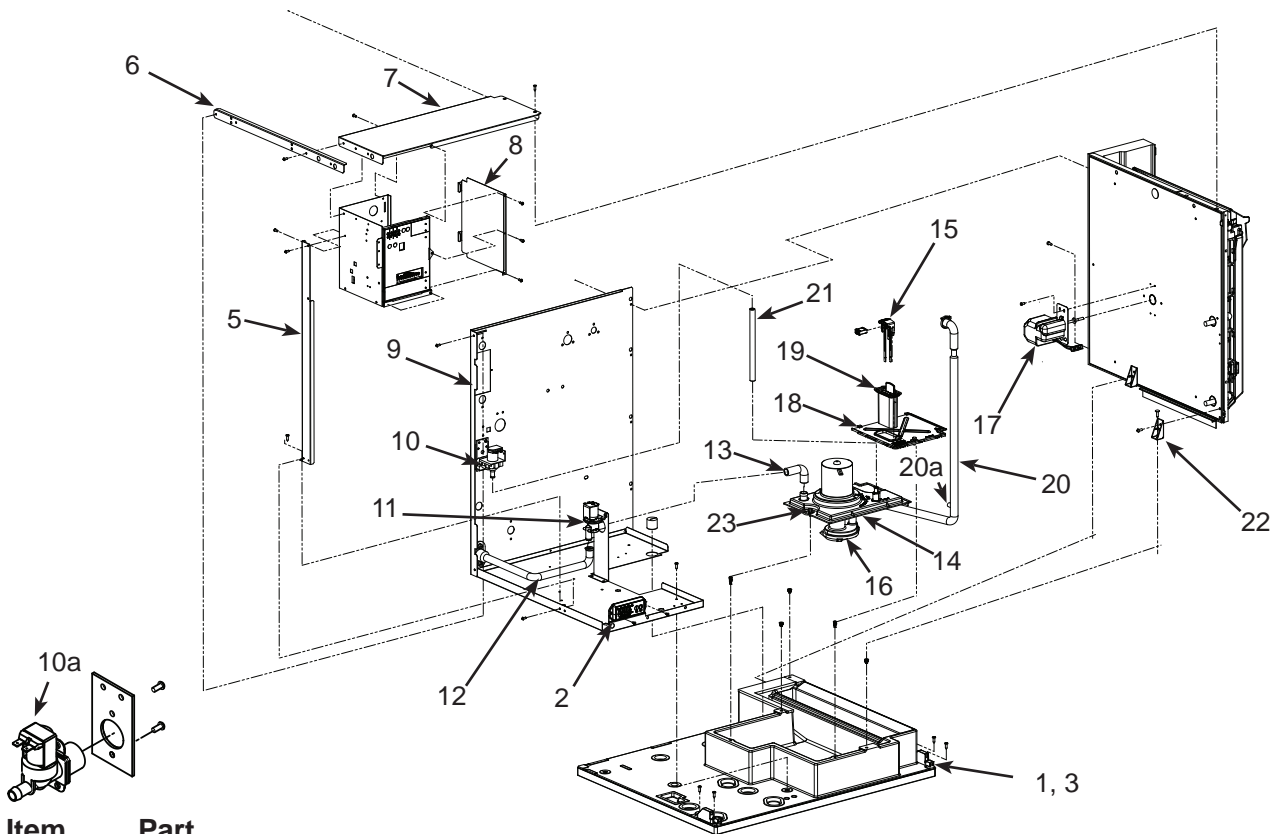

Item Number	Part Number	Description
1	15-0411-00	Strike (A series only)
2	11-0622-21	Light & switch panel
3	See page 4	Item # 13.13a.and 13b
4	A38732-001	Side panel mount A-C model
5	A38607-001	Strut, 0330-630
	A38629-001	Strut, 0830, C1030
6	A38582-001	Brace A thru C
	A40282-001	Brace D
7	A38539-002	Control box top A thru C
	A40283-001	Control box top, D
8	A38537-001	Control box side
9		Back panel, see page 14-15
10	12-3124-01	Inlet water sol vlv, 115 volt
	12-3124-02	Inlet water sol vlv, 230 volt
	12-2912-01	Water valve rebuild kit
10a	11-0568-02	Inlet water sol vlv, CE mod
11	11-0564-01	Purge valve, 115 volt
	11-0564-02	Purge valve, 230 volt
12	A38860-002	Drain tube
13	A38860-001	Drain hose

14	02-4164-01	Water pump bracket
15	A39030-021	Water level sensor
16	see table	Water pumps

Models	115 volt	208-230/60	50 Hz
0330, 0530	12-2919-21	12-2919-22	12-2919-26
0630	-	12-2919-22	12-2919-26
0830, 1030	-	12-2920-23	12-2920-25

17	see table	Harvest assist mechanism
----	-----------	--------------------------

Models	115 volt	208-230 volt
0330, 0530	12-3060-21	12-3060-22
0630, 0830, 1030	-	12-3060-22

18	02-4647-01	Sump cover, use/w item 19
19	02-4646-01	WLS guard, use/w item 18
20	02-4154-03	Pump hose, 0830-1030
	02-4154-02	Pump hose, 0530-0630
	02-4154-01	Pump hose, 0330
20a	11-0515-21	Temp sensor set
21	13-0674-02	Fill hose order by ft
	15-0821-01	Fill hose, -6 CE models
22	02-4152-01	Gusset
23	03-0727-05	Thumbscrew

C0330, C0530, C0630, C0830, C1030 Service Parts

Evaporator Compartment

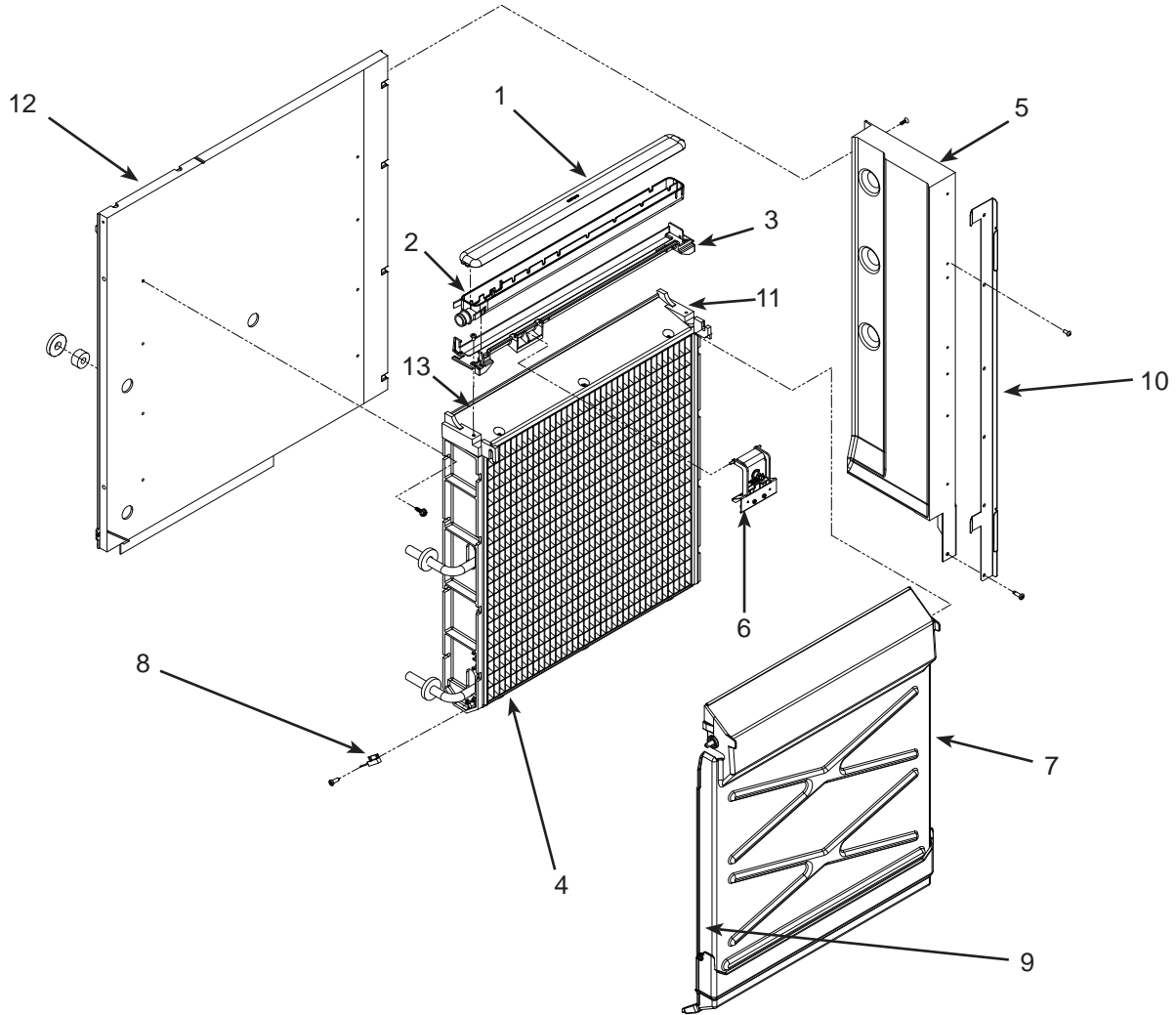

Item Number	Part Number	Description
1	02-4065-01	Water distributor cover
2	02-4064-01	Water distributor
3	02-4205-01	Mounting bracket
4	see table	Evaporator
5	A38596-001	Back wall, 0330, 0530, 0630
	A38598-001	Back wall, 0803, 1030
6	A39031-021	Ice thickness sensor
7	02-4100-31	Curtain, 0330
	02-4100-32	Curtain, 0530, 0630
7a	02-4611-21	Curtain, 0830, 1030
8	11-0563-01	Curtain switch
9	11-0563-02	Curtain switch magnet
10	02-4067-01	Side panel support short A*
	A39560-001	Liner retainer, short B & C*
	02-4067-03	Side panel support, long A*
	A39584-001	Liner retainer long B*
11	03-1418-30	Mounting screw
12	13-0943-01	Gasket tape
13	02-4156-21	Spillway replacement kit

Note: Item 7 includes item 9, shipped loose.

Item 7a magnet is molded into curtain.

Short is 0330, 0530, 0630. Long is 0830 & 1030.

C0330, C0530, C0630, C0830, C1030 Service Parts

Air Cooled Refrigeration System

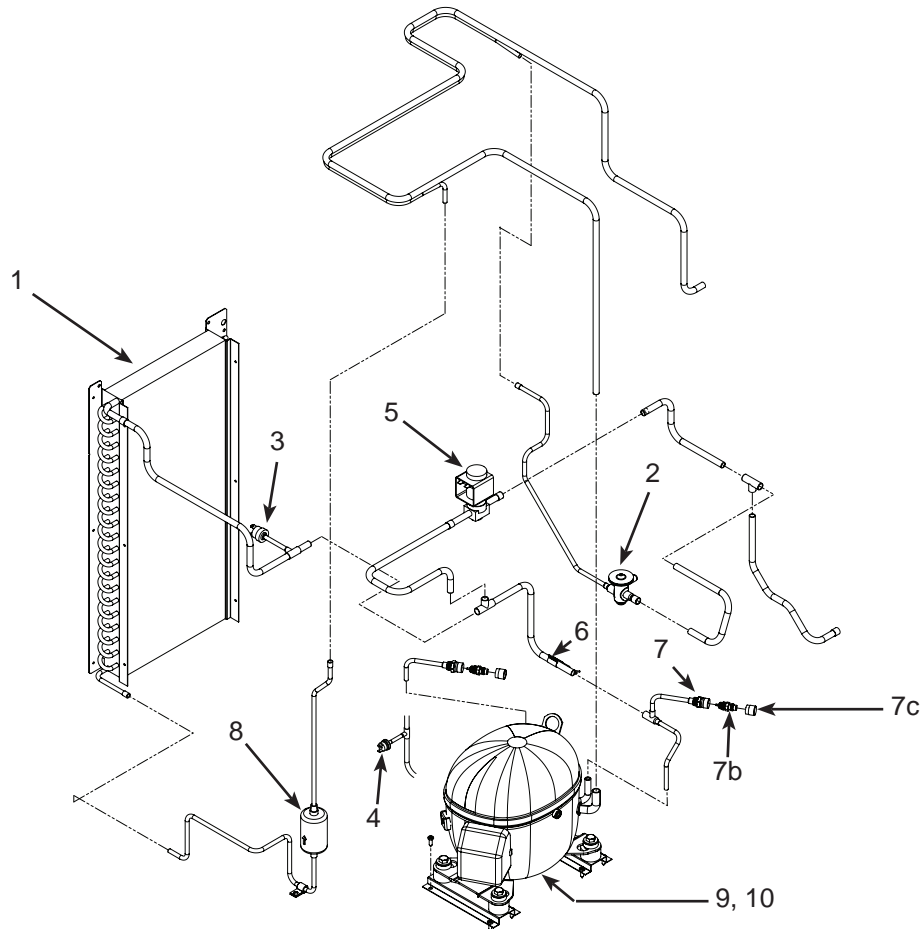

Item Number	Part Number	Description	Item Number	Part Number	Description
1	18-8890-01	Condenser, AC, 0330	5	11-0493-02	Hot gas valve, 115 volt
	18-8920-01	Cond, AC, C0530 - A series		12-2719-21	115 volt coil
	18-8935-01	Cond, AC, 0530 - B - D series		11-0493-01	Hot gas valve, 230 volt
	18-8896-01	Condenser, AC, 0630		12-2719-22	230 volt coil
	18-8895-01	Condenser, AC, 0830, 1030	6	12-2733-30	HGV rebuild kit
2	16-1182-02	TXV, C0530 A or B Series	6	11-0515-21	Thermistor
	16-1184-01	TXV, 0530 C, D, or E series	7	16-1137-01	3/8" Valve body
	16-1182-01	TXV, 0630	7a	16-1138-01	1/4" Valve body
	16-1183-02	TXV, 0330	7b	16-1139-01	Core
	16-1142-01	TXV, 0830, 1030	7c	16-1140-01	Cap
	19-0599-06	Insulation, TXV	8	02-3319-01	Dryer 0330 thru 0630
3	11-0566-21	Fan cycle pressure sw.	8	02-3319-02	Dryer 0830 & 1030
4	11-0501-05	Hi pressure cut out, 0330 A-B series, 0530 A-B series and 0630	9	see page 17	Compressors
			10	see page 17	Compressor mounting hdw
			11	11-0515-21	Temp sensor set
					Access valve changed 4-08. Prior valve:
				16-0832-20	Access valve
				16-0832-03	Port cap
				16-0832-02	Stem cap

C0330, C0530, C0630, C0830, C1030 Service Parts

Fan and Condenser Area C0330

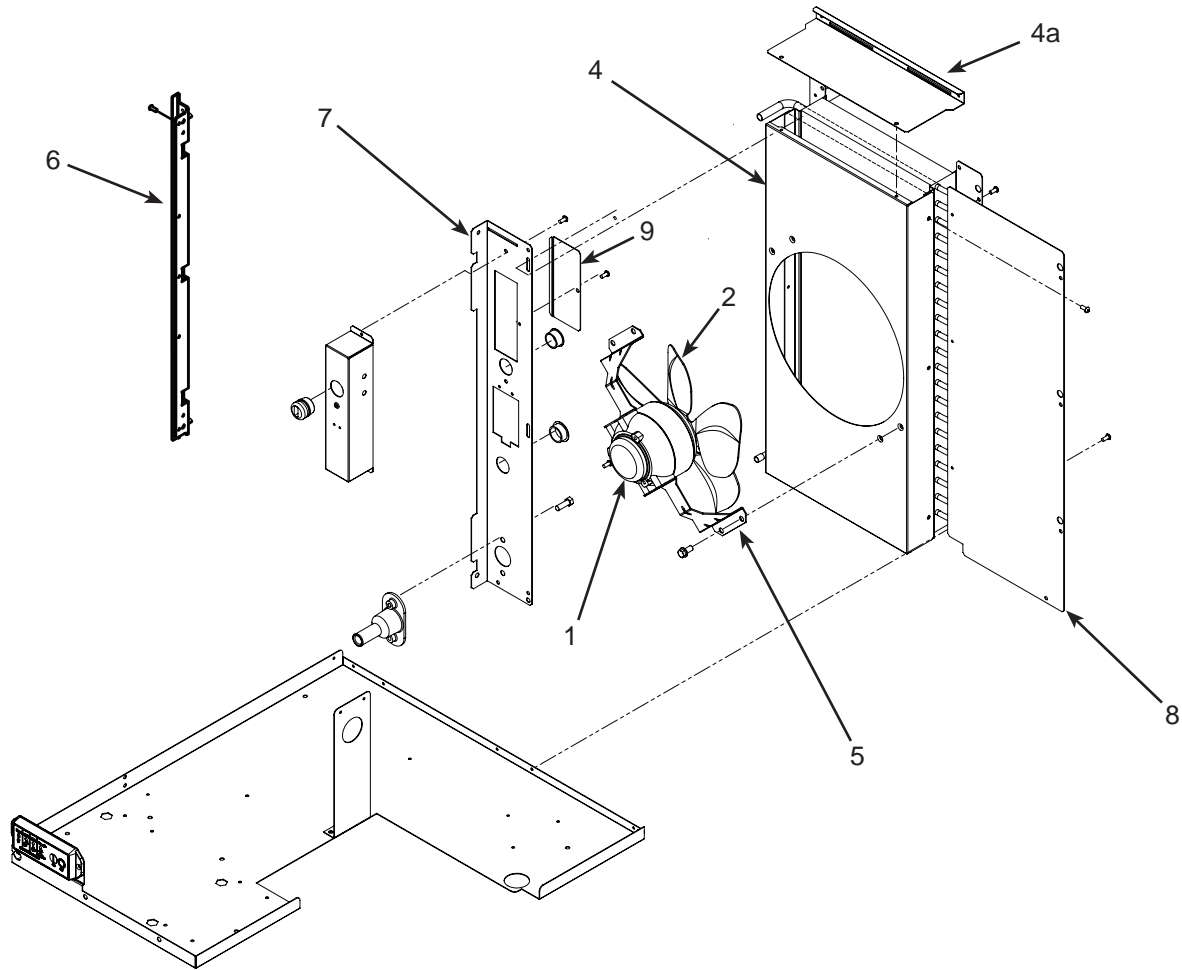

Item Number	Part Number	Description	Item Number	Part Number	Description
1	12-1681-23	Fan motor, 0330, 115 volt	10		
	12-1681-04	Fan motor, 0330, 230 volt			
2	18-8836-01	Fan blade, 0330			
3	02-3692-21	Drain adapter - also for WC and RC			
4	A38841-001	Fan shroud, 330 A Series			
	A39350-001	Fan shroud, 0330 B,C,D,E Series			
4a	A39593-001	Fan shroud top, B,C,D,E series			
5	A38480-001	Fan motor bracket, 0330			
6	02-4067-02	Side panel support, 0330, 0530, 0630 A Series Only			
7	A38791-001	Utility channel, (Air Cooled) A series			
	A40418-001	Utility channel, (Air Cooled) B,C,D,E			
8	A39606-001	Back panel, B,C,D,E series			
9	A38548-002	Junction box cover			

C0330, C0530, C0630, C0830, C1030 Service Parts

Fan and Condenser Area C0530 thru C0830

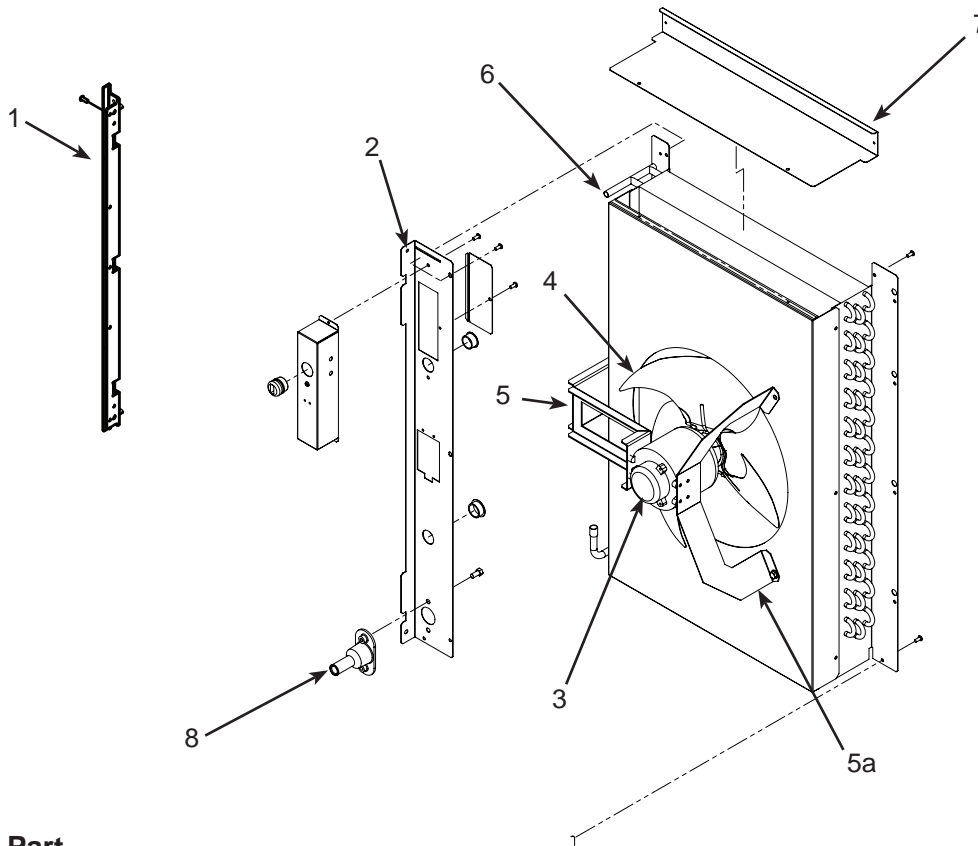

Item Number	Part Number	Description	Voltage/Hz	Fits Model	Fits series
1	02-4067-02	Side panel support		C0330-0630	A only
	02-4067-04	Side panel support		C0830-1030	A only
2	A38791-001	Utility channel		C0330-0630	A
	A40420-001	Utility channel		C0830-1030	B-D
3	18-8926-01	Fan motor	115/60	C0530-1	A-D
	18-8927-01	Fan motor	208-230/60	C0530, C0630, C0830-32,-3	A-D
4	18-8882-01	Fan blade		C0530, C0630, C0830	A-D
5	A38554-001	Fan motor bracket		C0530, C0630, C0830	A-C*
	A40156-001	Fan motor bracket, right		C0530, C0630, C0830	C**-D
5a	A40148-001	Fan motor bracket, left		C0530, C0630, C0830,	C**-D
6	A39607-001	Fan shroud		C0530, C0630	A-C*
	A36603-001	Fan shroud		C0830	A-C*
	A40146-001	Fan shroud		C0530, C0630	C**-D
	A40147-001	Fan shroud		C0830	C**-D
7	A39608-001	Shroud top		C0530, C0630	B-D
	A39601-001	Shroud top		C0830	B-D
8	02-3692-21	Drain adapter		all	

* Up to serial number 13031320011477. Fan blade flush with end of motor shaft.

** Beginning serial number 13031320011477. Then fan blade is .25" from end of shaft.

C0330, C0530, C0630, C0830, C1030 Service Parts

Fan and Condenser Area C1030

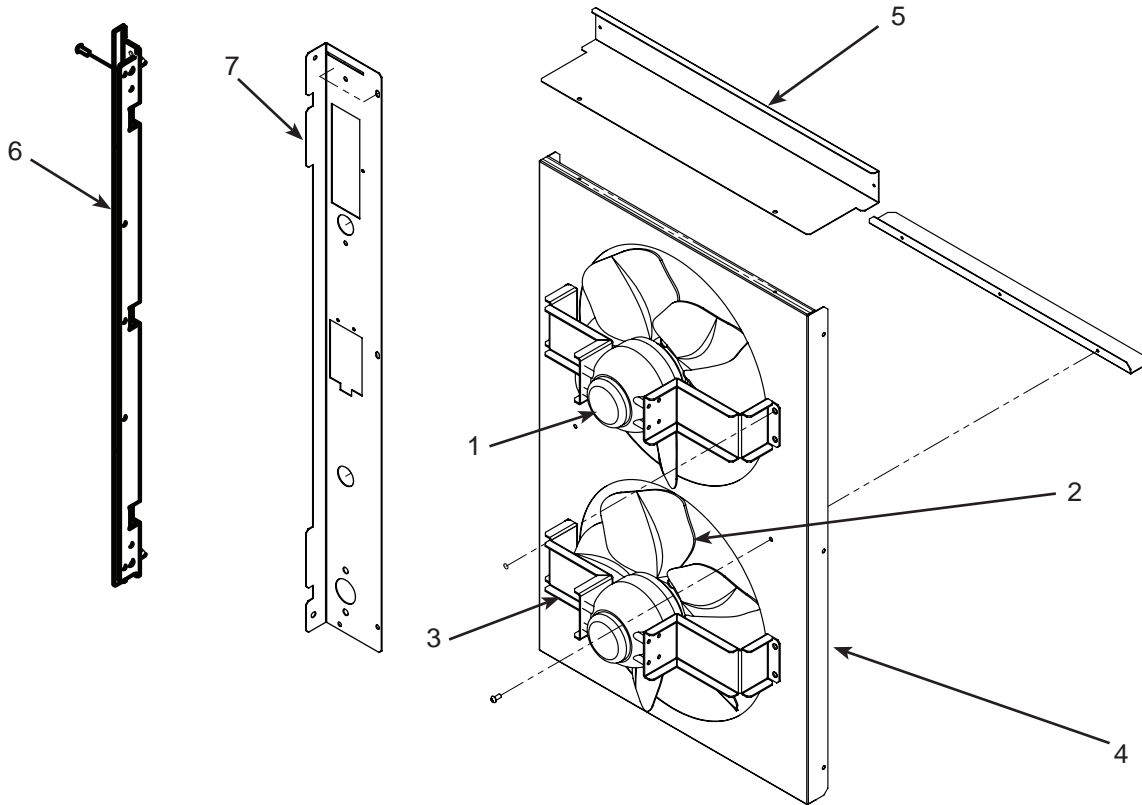

Item Number	Part Number	Description	Voltage/Hz	Fits Model	Fits series
1	18-8899-01	Fan motor	208-230/60	C1030-32, -3	A-D
	18-8899-06	Fan motor	230/50	C1030-6	A-D
2	18-8900-01	Fan blade	-	C1030	A-D
3	A38655-001	Fan motor bracket		C1030	A-D
4	A38624-001	Fan shroud		C1030	A-D
5	A39610-001	Fan shroud top		C1030	B-D
6	02-4067-04	Side panel support		C0830-1030	A only
7	A40420-001	Utility channel		C0830-1030	B-D

C0330, C0530, C0630, C0830, C1030 Service Parts

Water Cooled Refrigeration System

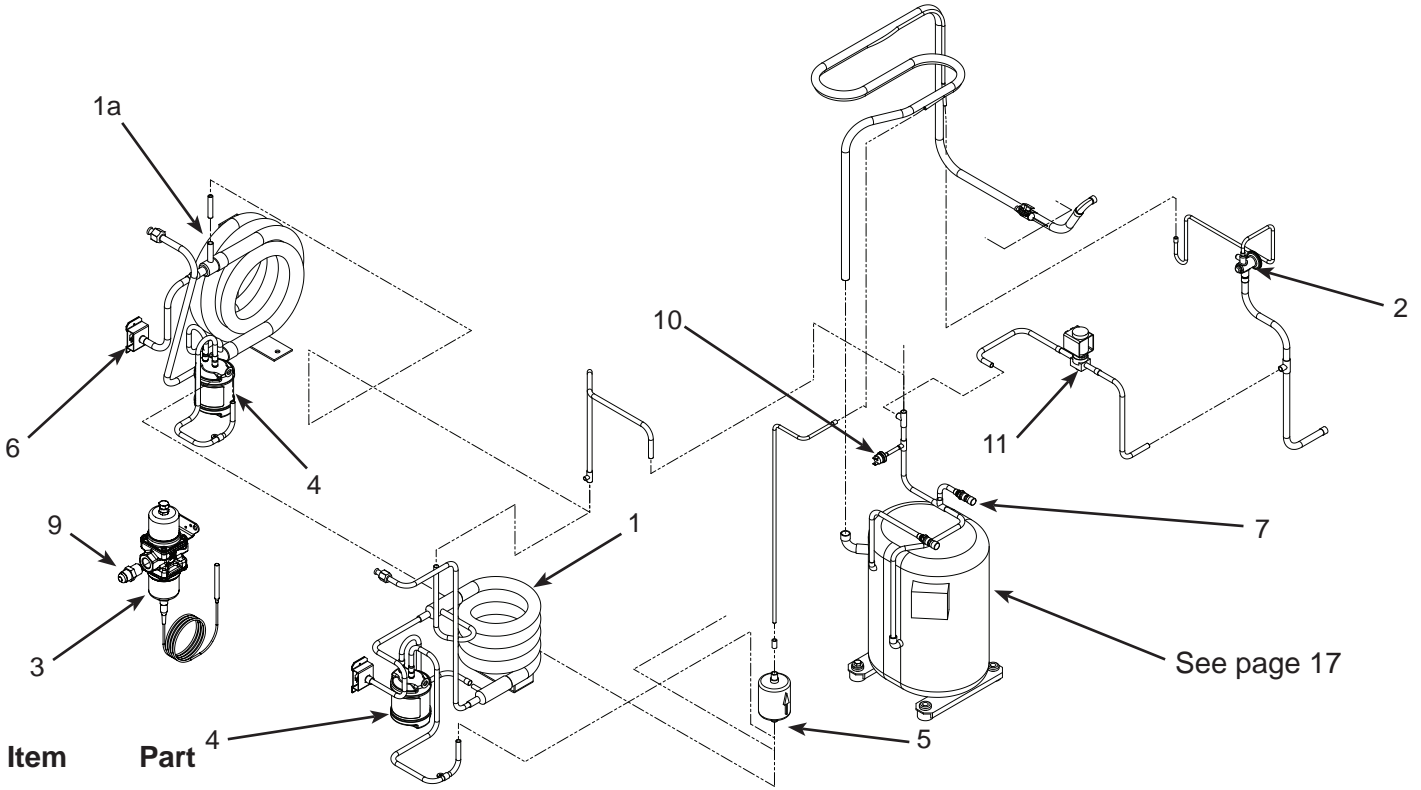

Item Number	Part Number	Description
1	18-8871-21	Condenser, WC, C0330, C0530, C0630, C0830
1a	18-8893-21	Condenser, WC, C1030
2	16-1182-02	TXV, C0530 A or B series
	16-1184-01	TXV, C0530 C series
	16-1182-01	TXV, C0630
	16-1183-02	TXV, C0330
	16-1142-01	TXV, C0830, C1030
	19-0599-06	Insulation TXV
3	11-0608-21	Water regulating valve
4	16-0874-01	Receiver, C0830, C1030
5	02-3319-01	Dryer, C0330 thru C0630
	02-3319-02	Dryer, C0830 - C1030
6	A31828-002	Condenser drain
7	16-1137-01	Valve body 3/8"
7a	16-1138-01	Valve body 1/4"
8	16-1063-01	Strainer no longer used
9	16-0355-00	Half union
10	11-0501-21	High pressure cut out
10	11-0501-21	High pressure cut out
11	11-0493-02	Hot gas valve, 115 volt
	11-0493-01	Hot gas valve, 230 volt
	12-2719-22	230 volt coil
	12-2733-30	HGV rebuild kit
12	16-1063-01	Strainer no longer used
	A38634-001	Back pnl, WC - A Series 23"
	A38625-001	Back pnl, WC - A Series 29"
	A39561-001	Back pnl, WC - B/C series 23"
	A39573-001	Back pnl, WC - B Series 29"
	A40417-001	Back pnl, WC - D series 23"
	A40515-001	Back pnl, WC - E series 23"
	A40654-001	back pnl. cover WC - E series
	A40419-001	Back pnl, WC - D series 29"
	A40522-001	Back pnl, WC - E series 29"
	16-0832-20	Access valve (for hex wrench)
	16-0832-03	Port cap
	16-0832-02	Stem cap
	16-1139-01	Core (for item #7)
	16-1140-01	Cap (for item #7)

Not Illustrated

C0330, C0530, C0630, C0830, C1030 Service Parts

Remote Refrigeration System

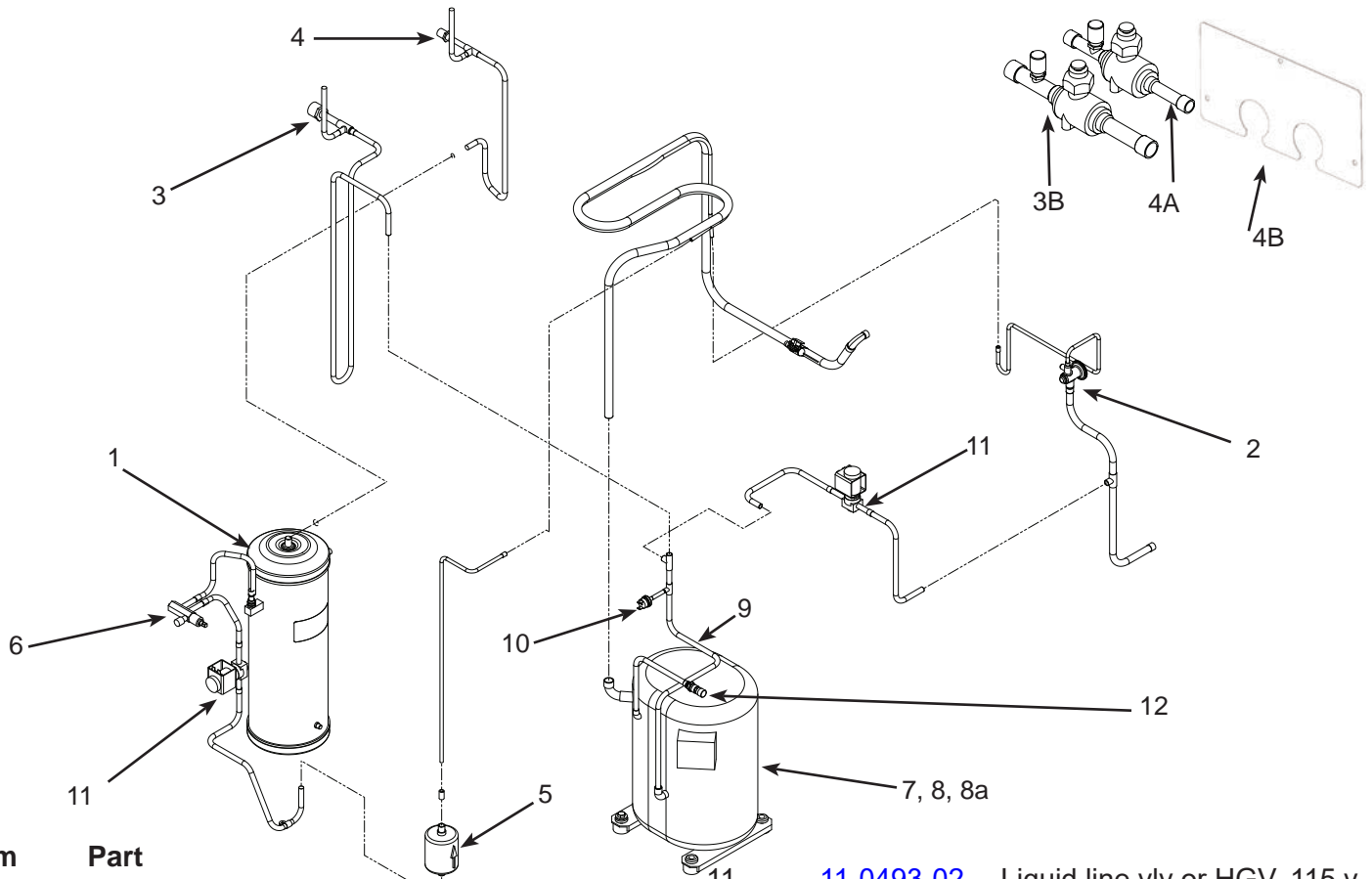

Item Number	Part Number	Description	Part Number	Description
1	16-1176-01	Receiver, C0530, C0630	11-0493-02	Liquid line vlv or HGV, 115 v
	16-1175-01	Receiver, C0830, C1030	11-0493-01	Liquid line vlv or HGV, 230 v
2	16-1182-02	TXV, C0530 A or B series	12	3/8" Valve body
	16-1184-01	TXV, C0530 C series	12a	1/4 Valve body
	16-1182-01	TXV, C0630	16-1140-01	Cap (for #12)
	16-1142-01	TXV, C0830, C1030	16-1139-01	Core (for #12)
	19-0599-06	Insulation, TXV	16-1063-01	Strainer - no longer used
3	16-0850-01	Discharge quick connect	A37211-001	Top receiver bracket
3A	16-1208-02	Discharge Isolation valve E Series	A37212-001	Bottom receiver bracket
4	16-0850-03	Liquid quick connect	A38664-001	Back pnl, RC - A series 23"
4A	16-1208-01	Liquid Isolation valve E Series	A38665-001	Back pnl, RC - A series 29"
4B	A40508-001	Cover Isolation valves E Series	A39561-001	Bck pnl, RC - B/C series 23"
5	02-3319-02	Drier	A39573-001	Back pnl, RC - B Series 29"
6	16-1030-01	Liquid line access valve	A40416-001	Back pnl, RC - D series, 23"
7	see page 17	Compressors	A40419-001	Back pnl, RC - D series, 29"
8	see page 17	Compressor mounting hdw	A40522-001	Back pnl. RC/WC - E Series. 29"
8a	see page 17	Crankcase heater	A40507-001	Isolation Valve bracket E Series
9	11-0515-21	Thermistor		
10	11-0501-22	High pressure cut out		

Not Illustrated

C0330, C0530, C0630, C0830, C1030 Service Parts

Electrical and Control Box

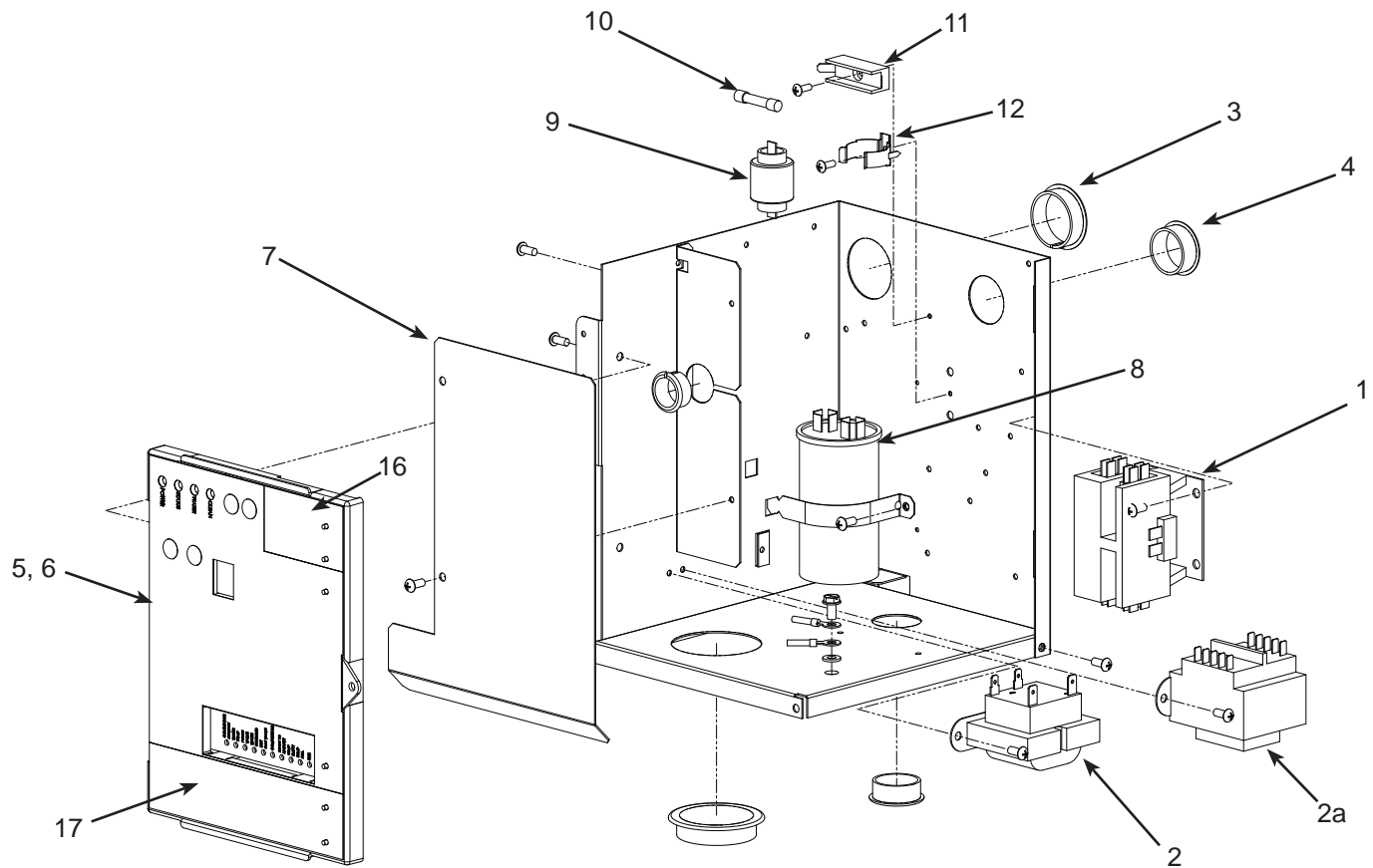

Item Number	Part Number	Description
1	12-2469-03	Contactor, 115 volt
	12-2469-02	Contactor, 230, single ph
	12-2533-02	Contactor, three phase
2	12-2924-01	Transformer, 115 volt
	12-2924-02	Transformer, 230 volt
2a	12-2639-01	Transformer, 50 Hz
3	12-1213-11	Snap bushing
4	12-1213-15	Snap bushing
5	11-0550-28	Service controller, thru C series
	11-0621-21	Service controller, fits all Prodigy cubers
6	02-4076-01	Control box door
	02-4189-01	Overlay label
7	A39216-001	Barrier
8		see next page Run capacitor
9		see next page PTCR -
10	12-2686-01	Fuse, 50 Hz only
11	12-2687-01	Fuse holder
12	18-8835-02	Bracket
Wiring Harnesses (not illustrated)		
13	12-2931-01	Power harness, A & W
	12-2931-02	Power harness, Remote
Power harness connects to J1 on controller		
14	12-2932-01	Hi voltage harness, A & W
	12-2933-01	Hi voltage harness, Rem
	12-3064-01	Hi voltage, 50 Hz A & W
Hi voltage harness has the 8 pin connector		
15	12-2928-02	WLS harness
16	KVS	Vari-smart ice level control
17	KSBUN	

Items 16 and 17 standard on CB models.

C0330, C0530, C0630, C0830, C1030 Service Parts

Compressors

Model	Series	Electrical	Compressor	Overload	Run Capacitor	PTCR
C0330-1	A or B	115/60/1	18-8897-21	18-8897-23*	18-1902-69*	18-8835-01*
C0330-6	A or B	230/50	18-8897-26	18-8897-28*	18-1902-57*	18-8835-01*
C0330-32	A or B	208-230/60/1	18-8897-22	18-8897-27*	18-1902-57*	18-8835-01*
C0330-1	C-E	115/60/1	18-8948-21	18-8948-50*	18-1902-64*	18-8835-01*
C0330-6	C-E	230/50	18-8948-22	18-8948-51*	18-1902-65*	18-8835-01*
C0330-32	C-E	208-230/60/1	18-8948-23	18-8948-51*	18-1902-30*	18-8835-01*
C0530-1	A or B	115/60/1	18-8921-21	18-8921-23*	18-1902-45*	18-8835-01*
C0530-6	A or B	230/50	18-8921-26	18-8774-27*	18-1902-68*	18-8835-01*
C0530-32	A or B	208-230/60/1	18-8921-22	18-8774-28*	18-1902-68*	18-8835-01*
C0530-1	C-E	115/60/1	18-8948-21	18-8948-50*	18-1902-64*	18-8835-01*
C0530-6	C-E	230/50	18-8948-22	18-8948-51*	18-1902-65*	18-8835-01*
C0530-32	C-E	208-230/60/1	18-8948-23	18-8948-51*	18-1902-30*	18-8835-01*
C0630-32	A-D	208-230/60/1	18-8922-22	18-8922-27*	18-1902-57*	18-8835-01*
C0630-32	E	208-230/60/1	18-8955-22	internal	18-1902-67*	18-8835-01*
C0630-6	A-D	230/50	18-8922-26	internal	18-1902-71*	18-8835-01*
C0630-6	E	230/50	18-8990-26	internal	18-1902-63*	18-8835-01*
C0830-32	all	208-230/60/1	18-8813-23	internal	18-1902-69*	18-8835-01*
C0830-6	all	230/50	18-8813-27	internal	18-1902-69*	18-8835-01*
C0830-3	all	208-230/60/3	18-8813-25	internal	-	-
C0830-63	B	440/50/3	18-8813-08	internal	-	-
C1030-32	A-D,F	208-230/60/1	18-8726-23	internal	18-1902-69*	18-8835-01*
C1030-32	E	208-230/60/1	18-8980-21	internal	18-1902-70*	18-8835-01*
C1030-6	All	230/50	18-8726-27	internal	18-1902-69*	18-8835-01*
C1030-3	A-D,F	208-230/60/3	18-8726-25	internal	-	-
C1030-3	E	208-230/60/3	18-8980-22	internal	-	-
CA1030-6	B	230/50/1	18-8749-27	internal	18-1902-70*	18-8835-01*

* Replacement compressors include selected components and a filter dryer. They may also include other components used only on other models. CS type compressors include fittings to adapt to prior tubing sizes.

C0330, C0530, C0630, C0830, C1030 Service Parts

Compressor Mounting Hardware / Crankcase Heater

Model	Series	Bolt	Washer	Grommet	Sleeve
C/CB 0330	all	03-1405-20	03-1407-07	18-4700-28	18-0108-41
C0530	A or B	03-1405-20	03-1407-07	18-4700-28	18-0108-41
C/CB 0330 or 0530	C,D,E	03-1405-20	03-1407-07	18-2200-28	18-2200-27
C/CB 0630	all	03-1405-20	03-1407-07	18-4700-28	18-0108-41
C0630	E	03-1405-20	03-1407-07	18-2200-28	18-2200-27
C/CB 0830 or 1030	all	03-1405-20	03-1407-07	18-2300-27	18-2300-26

Model		Crankcase heater	
C0530R	A or B Series	12-2942-01	
C0530R	C Series	12-3043-01	
C0630R	A-D	12-2942-02	
C0630R	E	12-3043-02	
C0830R or C1030R	A-D	18-2308-01 internal	12-3043-03 * external
C1030R	E	12-1868-05 external	

* Replacement compressors include selected components and a filter dryer. They may also include other components used only on other models. CS type compressors include fittings to adapt to prior tubing sizes.

C0330, C0530, C0630, C0830, C1030 Service Parts

Remote Condenser, ERC111, ERC211 and ERC311

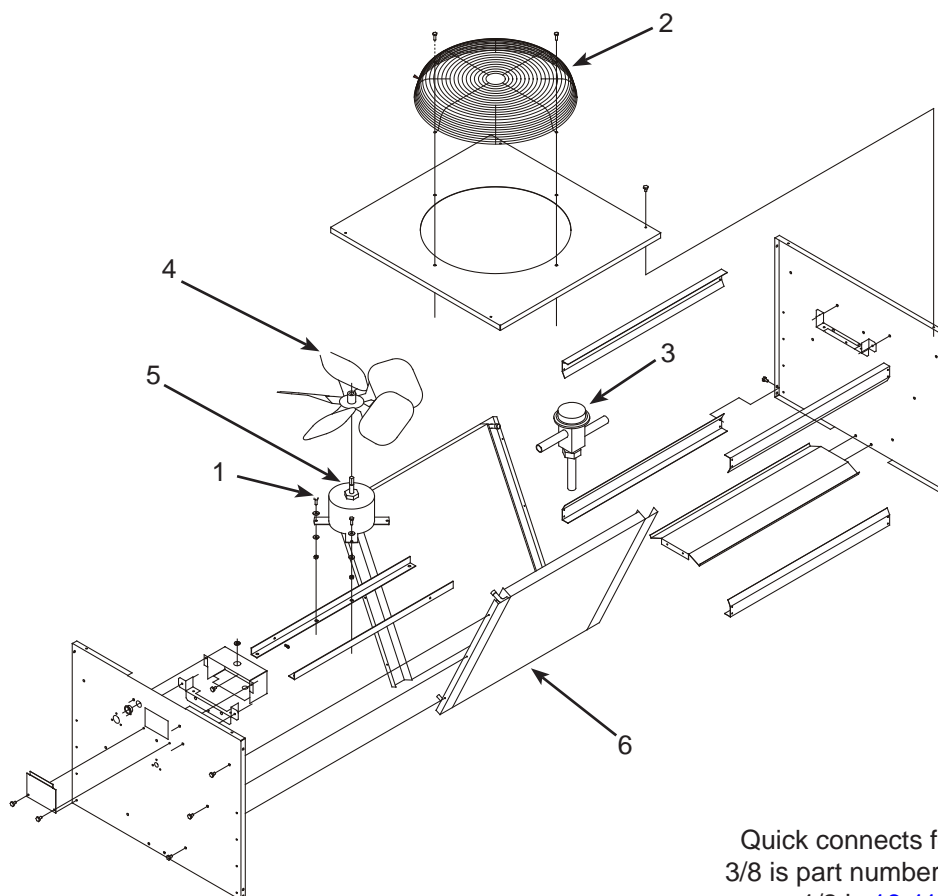

Quick connects for line sets:
 3/8 is part number [16-1100-08](#);
 1/2 is [16-1100-09](#).

Item Number	Part Number	Description
1	03-1405-08	Screw
2	02-3575-01	Fan guard
3	11-0422-22	Headmaster
4	18-8816-01	Fan blade
5	12-2651-01	Fan motor - 230 volt (ERC311)
	12-2651-02	Fan motor - 115 volt (ERC111 and ERC211)
6	18-8815-01	Coil, ERC111
	18-8827-01	Coil, ERC311

Not Shown:

A37169-001	Leg
A37170-001	Leg brace
03-1645-01	Screw for legs
16-0850-01	Quick connect, discharge
16-0850-03	Quick connect, liquid