

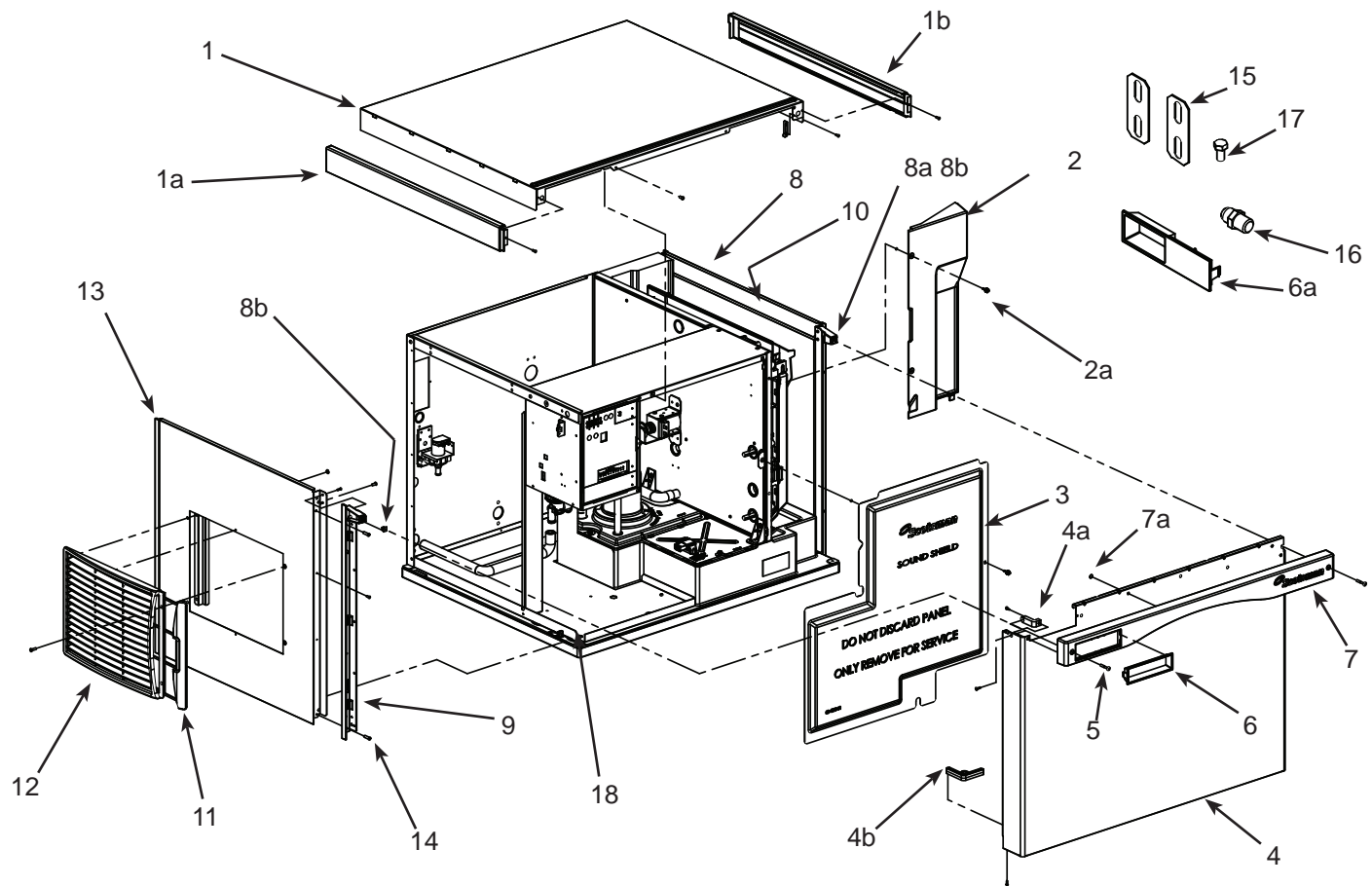

# C0330, C0530, C0630, C0830, C1030 Service Parts

## Cabinet - C0330, C0530, C0630 - A Series



Item Number	Part Number	Description
1*	A38941-022	Top panel, w/trim strips
1a	02-4221-01	Left trim strip
1b	02-4221-02	Right trim strip
2	02-4240-01	Evaporator cover
2a	03-0727-05	Screw
3	02-4218-01	Sound shield - discontinued late 2008
4*	A38552-022	Front panel assembly, includes trim strip, gussets and labels.
4a	02-4216-01	Top gusset
4b	02-4217-01	Bottom gusset
5	03-1735-03	Screw, front panel
6	02-4284-01	Bezel, full window
6a	02-4284-02	Bezel, partial window
7	02-4214-02	Trim strip
7a	03-1731-02	Push nut
8*	A38553-021	Right side panel assy
8a	02-4215-01	Receptacle
8b	03-3804-01	Screw receptacle
9	02-4067-01	Side panel support for water cooled and remote models
	02-4067-02	Side panel support for air cooled models
10	02-4336-01	Right side panel liner
11	02-4212-01	Air filter
12	02-4224-01	Louver panel
12a	A39222-001	Filter guide
12b	A39238-001	Louver bracket
13*	A38551-021	Left side panel, AC
	A38551-022	Left side panel WC, RC
14	03-1404-12	Screw
15	A30911-015	Machine straps
16	16-0355-00	Inlet water fitting, flare
17	03-1405-15	Screw
18	A38608-001	Compressor deck

\*Note: All panels supplied complete as used on unit

# C0330, C0530, C0630, C0830, C1030 Service Parts

## Cabinet - 0330, 0530, 0630 - B or C Series

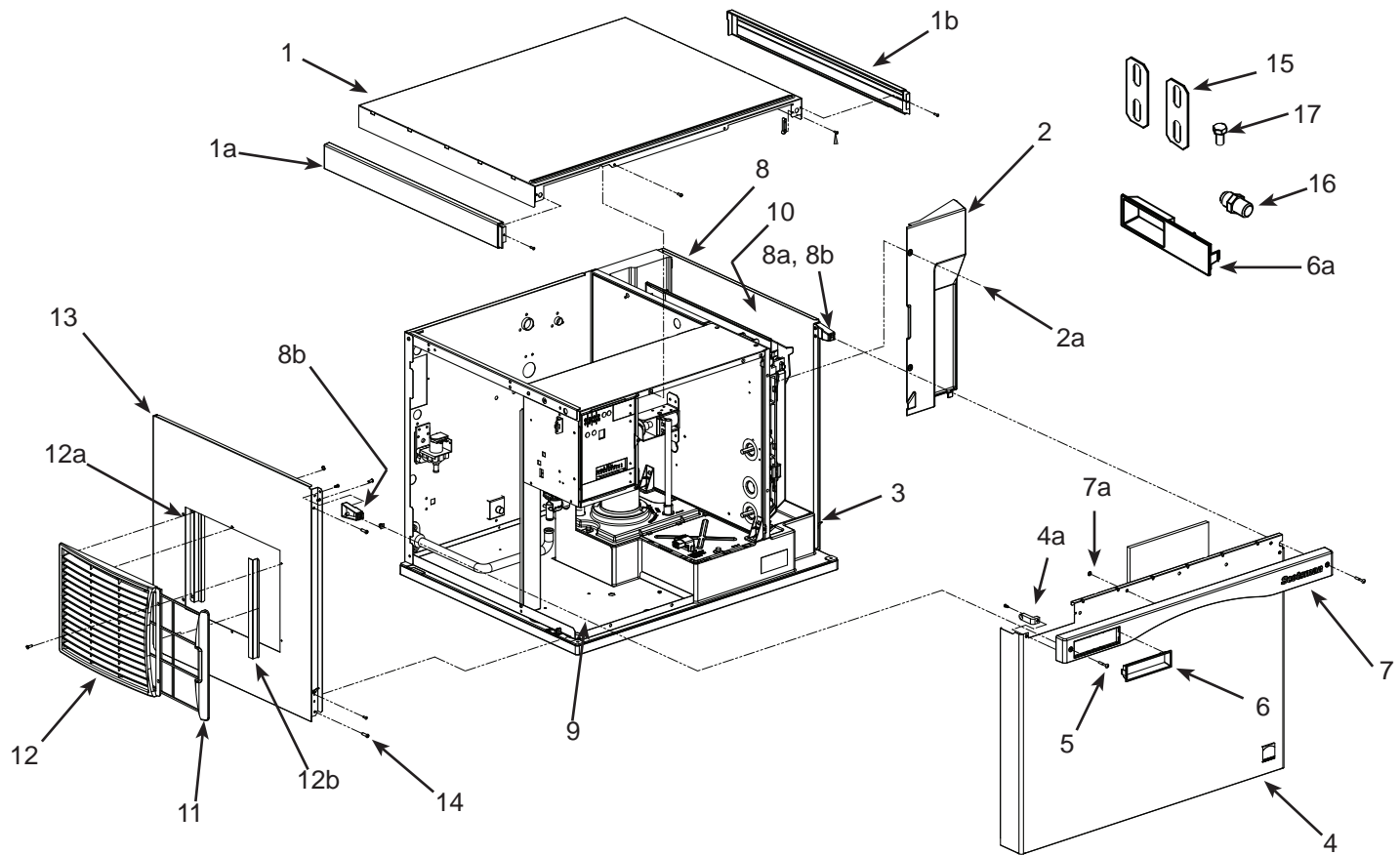

Item Number	Part Number	Description	Item Number	Part Number	Description
1	A39579-022	Top panel	8b	03-3804-01	Screw receptacle
1a	02-4221-01	Left trim strip**	9	A38608-001	Compressor deck
1b	02-4221-02	Right trim strip**	10	02-4336-01	Right side panel liner
2	02-4240-01	Evaporator cover	11	02-4212-01	Air filter
2a	03-0727-05	Screw	12	02-4224-01	Louver panel
3	A39571-001	Side panel clip	12a	A39238-001	Louver bracket
4*	A39578-022	Front panel assembly, includes trim strip and labels.	13*	A39580-021	Left side panel, AC
4a	02-4216-01	Top gusset		A39580-022	Left side panel WC, RC
5	03-1735-03	Screw, front panel	14	03-1404-12	Screw
6	02-4284-01	Bezel, full window	15	A30911-015	Machine straps
6a	02-4284-02	Bezel, partial window***	16	16-0355-00	Inlet water fitting, flare***
7	02-4214-02	Trim strip	17	03-1405-15	Screw
7a	03-1731-02	Push nut			
8*	A39581-021	Right side panel assy			
8a	02-4215-01	Receptacle			

\*Note: All panels supplied complete as used on unit, except top panels do not have trim strips.

\*\* Trim strips discontinued mid 2011

\*\*\* Bezel and fitting discontinued from production 2/8/2012.

# C0330, C0530, C0630, C0830, C1030 Service Parts

## Cabinet - C0330, C0530, C0630 D and E Series

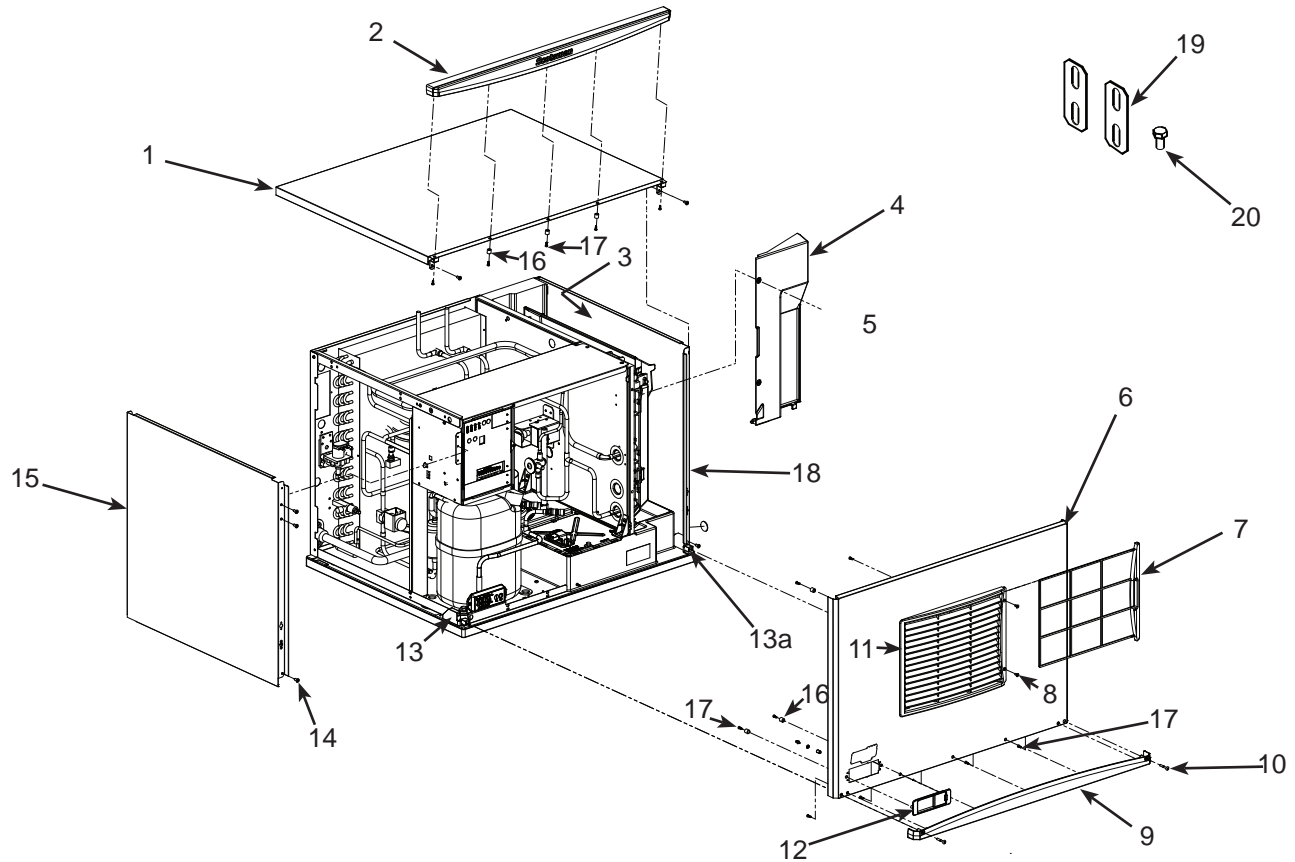

Item Number	Part Number	Description	Item Number	Part Number	Description
1	A40309-021	Top panel, includes item 2	12a	02-4822-01	Door, bezel with handle
2	02-4819-01	Trim strip	12b	02-4822-02	Door, bezel secure
3	02-4336-01	Right side liner	13	02-4823-21	*Panel mount kit, left
4	02-4240-01	Evaporator cover	13a	02-4823-22	*Panel mount kit, right
5	03-0727-05	Thumbscrew			*Includes both screw receptacles
6	A40308-021	Front panel, AC. Includes items 7, 8, 9, 10, 11, 12	14	03-1404-10	Screw
	A40308-022	Front panel, WC or RC. Includes items 9, 10, 11, 12	15	A40310-023	Left side panel, WC & RC
7	02-4212-03	Air filter		A40310-021	Left side panel, AC
8	03-1419-26	Screw	16	02-4824-01	Spacer
9	02-4820-01	Trim strip	17	03-3836-02	Screw
10	03-1735-03	Screw	18	A40311-021	Right side panel
11	02-4224-03	Louvers	19	A30911-015	Machine straps
12	02-4821-02	Bezel with standard door	20	03-1405-15	Screw

# C0330, C0530, C0630, C0830, C1030 Service Parts

## Cabinet - C0830, C1030 - A Series

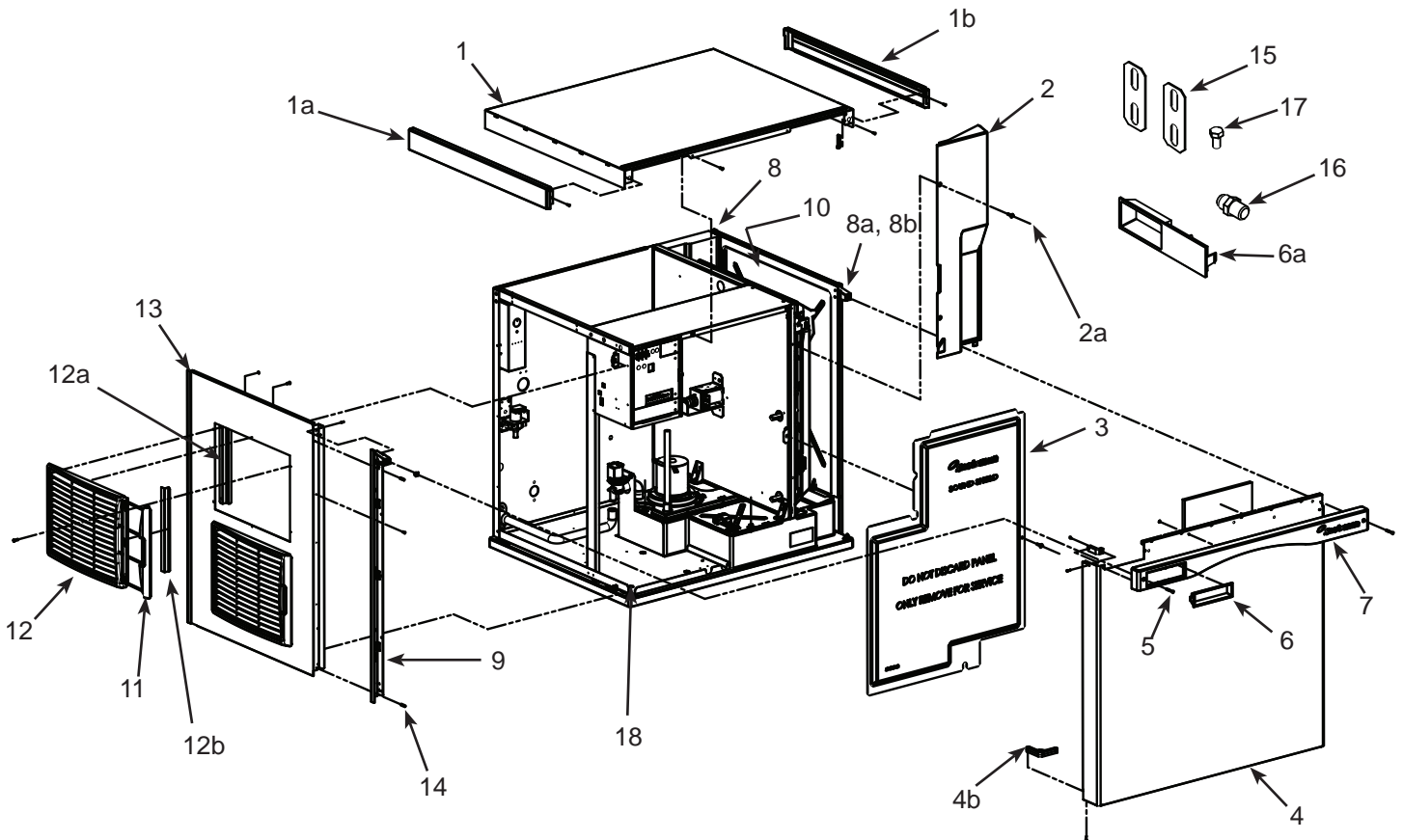

Item Number	Part Number	Description
1*	<a href="#">A38941-022</a>	Top panel, w/trim strips
1a	<a href="#">02-4221-01</a>	Left trim strip
1b	<a href="#">02-4221-02</a>	Right trim strip
2	<a href="#">02-4240-02</a>	Evaporator cover
2a	<a href="#">03-0727-05</a>	Screw
3	<a href="#">02-4218-02</a>	Sound shield - discontinued late 2008
4*	<a href="#">A38552-023</a>	Front panel assembly, includes trim strip, gussets and labels.
4a	<a href="#">02-4216-01</a>	Top gusset
4b	<a href="#">02-4217-01</a>	Bottom gusset
5	<a href="#">03-1735-03</a>	Screw, front panel
6	<a href="#">02-4284-01</a>	Bezel, full window
6a	<a href="#">02-4284-02</a>	Bezel, partial window
7	<a href="#">02-4214-02</a>	Trim strip (no spacers needed)
8*	<a href="#">A38553-022</a>	Right side panel assy
8a	<a href="#">02-4215-01</a>	Receptacle
8b	<a href="#">03-3804-01</a>	Screw receptacle
9	<a href="#">02-4067-03</a>	Side panel support for water cooled and remote models
	<a href="#">02-4067-04</a>	Side panel support for air cooled models
10	<a href="#">02-4336-02</a>	Right side panel liner
11	<a href="#">02-4212-01</a>	Air filter
12	<a href="#">02-4224-01</a>	Louver panel
12a	<a href="#">A39222-001</a>	Filter guide
12b	<a href="#">A39238-001</a>	Louver bracket
13*	<a href="#">A38551-023</a>	Left side panel, AC
	<a href="#">A38551-024</a>	Left side panel WC, RC
14	<a href="#">03-1404-12</a>	Screw
15	<a href="#">A30911-015</a>	Machine straps
16	<a href="#">16-0355-00</a>	Inlet water fitting, flare
17	<a href="#">03-1405-15</a>	Screw
18	<a href="#">A38611-001</a>	Compressor deck

\*Note: All panels supplied complete as used on unit.

# C0330, C0530, C0630, C0830, C1030 Service Parts

## Cabinet - C0830, C1030 - B Series

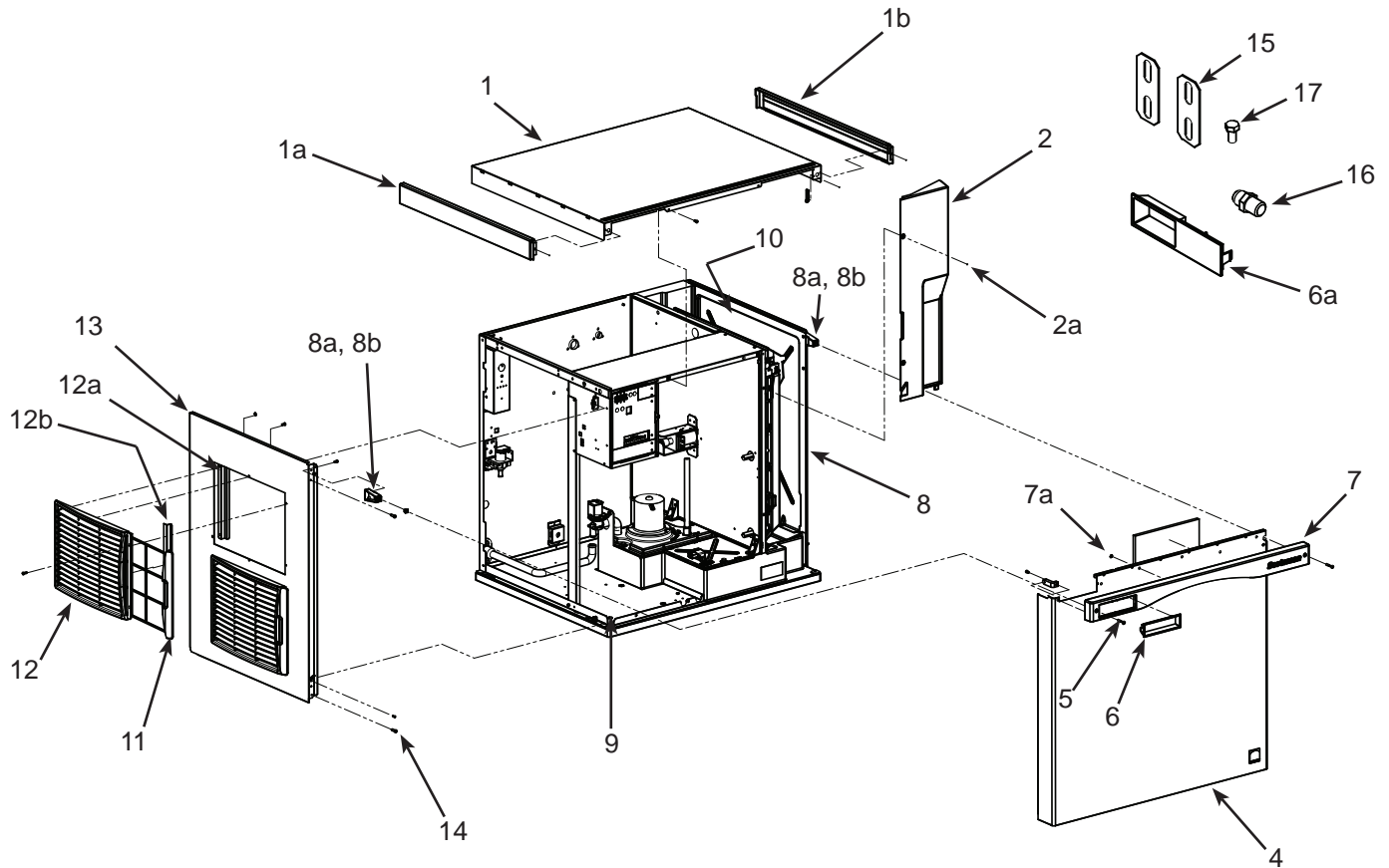

Item Number	Part Number	Description	Part Number	Description
1	A39579-022	Top panel	8b	03-3804-01 Screw receptacle
1a	02-4221-01	Left trim strip**	9	A38611-001 Compressor deck
1b	02-4221-02	Right trim strip**	10	02-4336-02 Right side panel liner
2	02-4240-02	Evaporator cover	11	02-4212-01 Air filter
2a	03-0727-05	Screw	12	02-4224-01 Louver panel
3	A39571-001	Side panel clip	12a	A39238-001 Louver bracket
4*	A39578-023	Front panel assembly, includes trim strip and labels.	13*	A39580-023 Left side panel, AC
4a	02-4216-01	Top gusset		A39580-024 Left side panel WC, RC
5	03-1735-03	Screw, front panel	14	03-1404-12 Screw
6	02-4284-01	Bezel, full window	15	A30911-015 Machine straps
6a	02-4284-02	Bezel, partial window***	16 1	6-0355-00 Inlet water fitting, flare***
7	02-4214-02	Trim strip	17	03-1405-15 Screw
	03-1731-02	Push nut		
8*	A39581-022	Right side panel assy		
8a	02-4215-01	Receptacle		

\*Note: All panels supplied complete as used on unit, except top panels do not have trim strips.

\*\* Trim strips discontinued mid 2011

\*\*\* Bezel and fitting discontinued from production 2/8/2012.

# C0330, C0530, C0630, C0830, C1030 Service Parts

## Cabinet - C0830, C1030 D and E Series

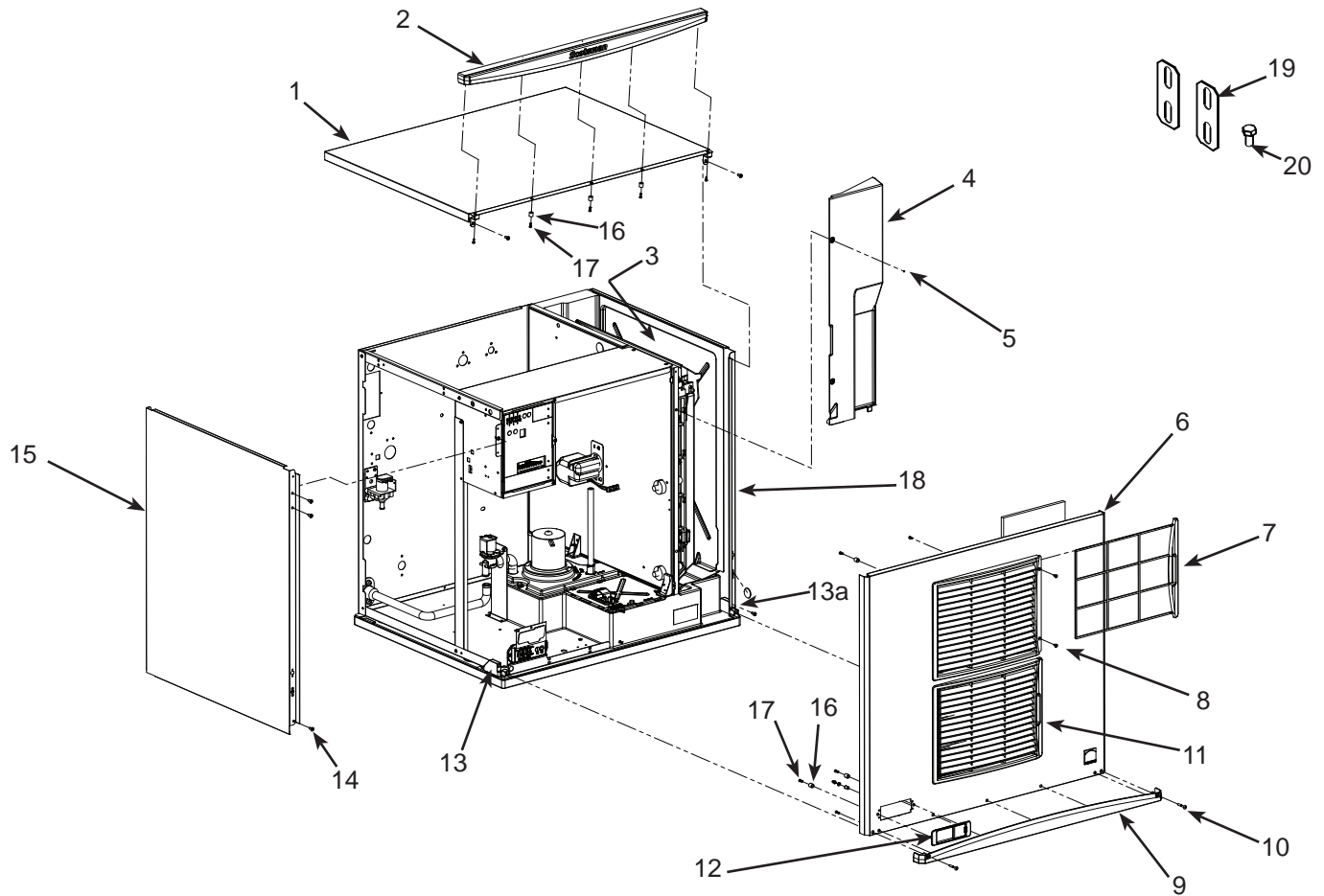

Item Number	Part Number	Description
1	A40309-021	Top panel, includes item 2
2	02-4819-01	Trim strip
3	02-4336-02	Right side liner
4	02-4240-02	Evaporator cover
5	03-0727-05	Thumbscrew
6	A40308-023	Front panel, AC. Includes items 7, 8, 9, 10, 11, 12
	A40308-024	Front panel, WC or RC. Includes items 9, 10, 12
7	02-4212-03	Air filter
8	03-1419-26	Screw
9	02-4820-01	Trim strip
10	03-1735-03	Screw
11	02-4224-03	Louvers
12	02-4821-02	Bezel with standard door
12a	02-4822-02	Door, bezel secure
13	02-4823-21	*Panel mount kit, left
13a	02-4823-22	*Panel mount kit, right
		*Includes both screw receptacles
14	03-1404-10	Screw
15	A40310-024	Left side panel, AC
	A40310-022	Left side panel, WC & RC
16	02-4824-01	Spacer
17	03-3836-02	Screw
18	A40311-022	Right side panel
19	A30911-015	Machine straps
20	03-1405-15	Screw

# C0330, C0530, C0630, C0830, C1030 Service Parts

## Interior Parts

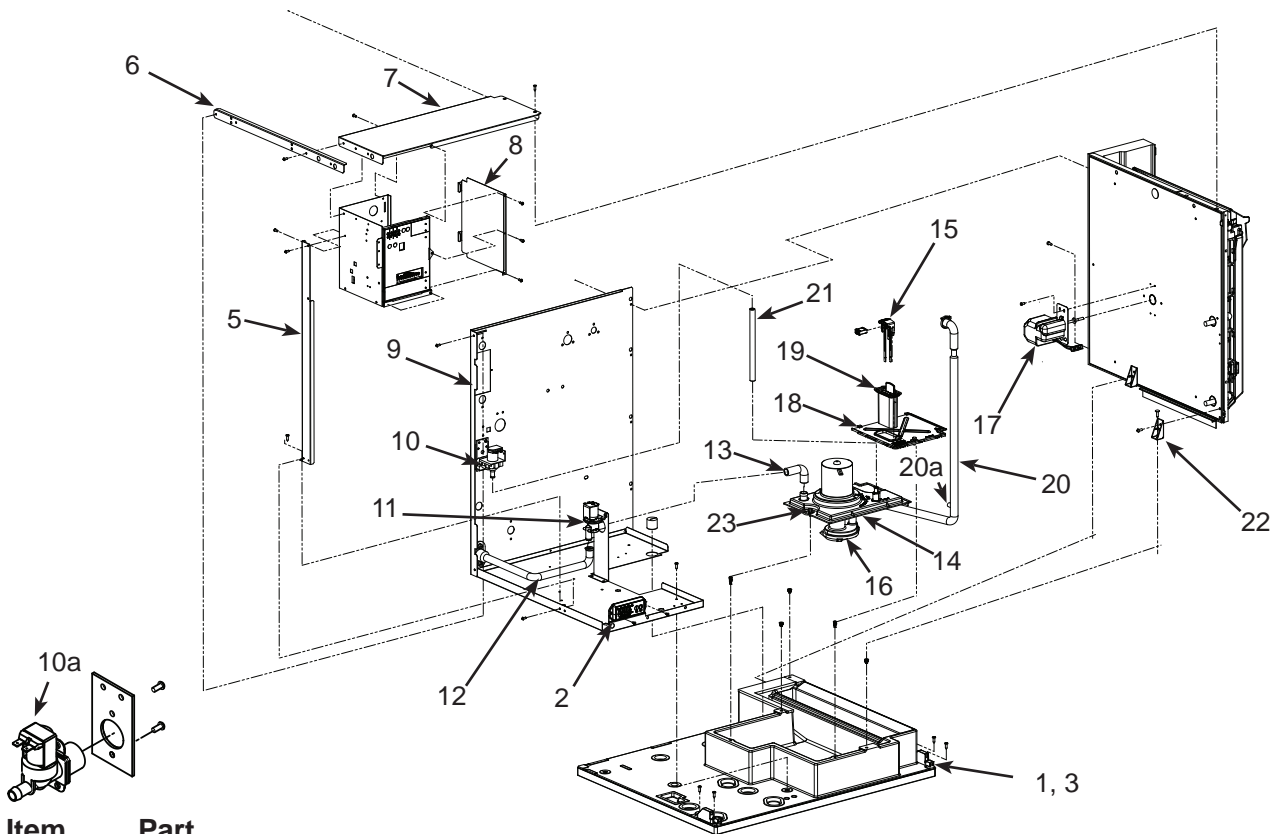

Item Number	Part Number	Description
1	15-0411-00	Strike (A series only)
2	11-0622-21	Light & switch panel
3	See page 4	Item # 13.13a.and 13b
4	A38732-001	Side panel mount A-C model
5	A38607-001	Strut, 0330-630
	A38629-001	Strut, 0830, C1030
6	A38582-001	Brace A thru C
	A40282-001	Brace D
7	A38539-002	Control box top A thru C
	A40283-001	Control box top, D
8	A38537-001	Control box side
9		Back panel, see page 14-15
10	12-3124-01	Inlet water sol vlv, 115 volt
	12-3124-02	Inlet water sol vlv, 230 volt
	12-2912-01	Water valve rebuild kit
10a	11-0568-02	Inlet water sol vlv, CE mod
11	11-0564-01	Purge valve, 115 volt
	11-0564-02	Purge valve, 230 volt
12	A38860-002	Drain tube
13	A38860-001	Drain hose

14	02-4164-01	Water pump bracket
15	A39030-021	Water level sensor
16	see table	Water pumps

Models	115 volt	208-230/60	50 Hz
0330, 0530	12-2919-21	12-2919-22	12-2919-26
0630	-	12-2919-22	12-2919-26
0830, 1030	-	12-2920-23	12-2920-25

17	see table	Harvest assist mechanism
----	-----------	--------------------------

Models	115 volt	208-230 volt
0330, 0530	12-3060-21	12-3060-22
0630, 0830, 1030	-	12-3060-22

18	02-4647-01	Sump cover, use/w item 19
19	02-4646-01	WLS guard, use/w item 18
20	02-4154-03	Pump hose, 0830-1030
	02-4154-02	Pump hose, 0530-0630
	02-4154-01	Pump hose, 0330
20a	11-0515-21	Temp sensor set
21	13-0674-02	Fill hose order by ft
	15-0821-01	Fill hose, -6 CE models
22	02-4152-01	Gusset
23	03-0727-05	Thumbscrew

# C0330, C0530, C0630, C0830, C1030 Service Parts

## Evaporator Compartment

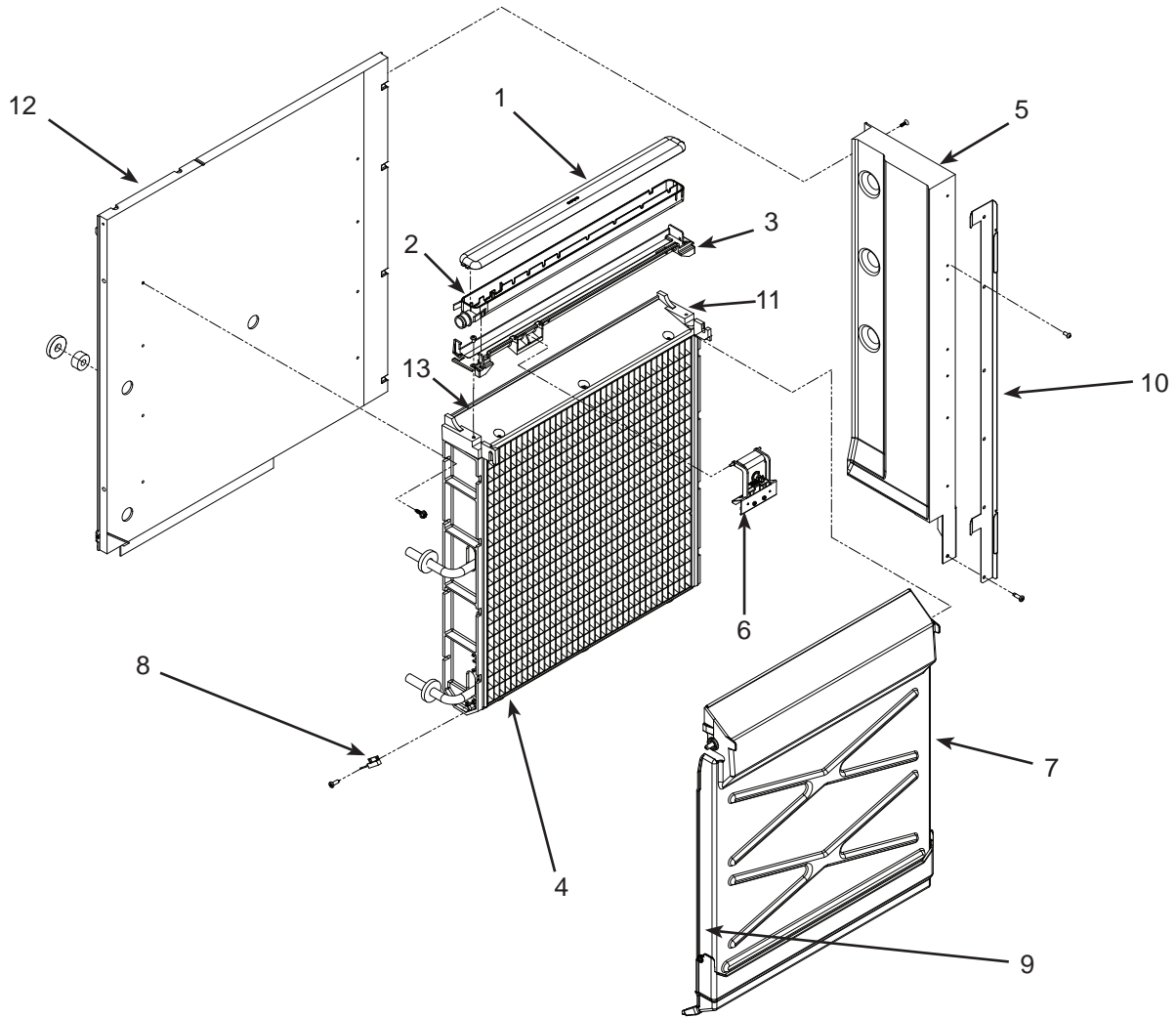

Item Number	Part Number	Description
1	02-4065-01	Water distributor cover
2	02-4064-01	Water distributor
3	02-4205-01	Mounting bracket
4	see table	Evaporator
5	A38596-001	Back wall, 0330, 0530, 0630
	A38598-001	Back wall, 0803, 1030
6	A39031-021	Ice thickness sensor
7	02-4100-31	Curtain, 0330
	02-4100-32	Curtain, 0530, 0630
7a	02-4611-21	Curtain, 0830, 1030
8	11-0563-01	Curtain switch
9	11-0563-02	Curtain switch magnet
10	02-4067-01	Side panel support short A*
	A39560-001	Liner retainer, short B & C*
	02-4067-03	Side panel support, long A*
	A39584-001	Liner retainer long B*
11	03-1418-30	Mounting screw
12	13-0943-01	Gasket tape
13	02-4156-21	Spillway replacement kit

Note: Item 7 includes item 9, shipped loose.

Item 7a magnet is molded into curtain.

Short is 0330, 0530, 0630. Long is 0830 & 1030.

# C0330, C0530, C0630, C0830, C1030 Service Parts

## Air Cooled Refrigeration System

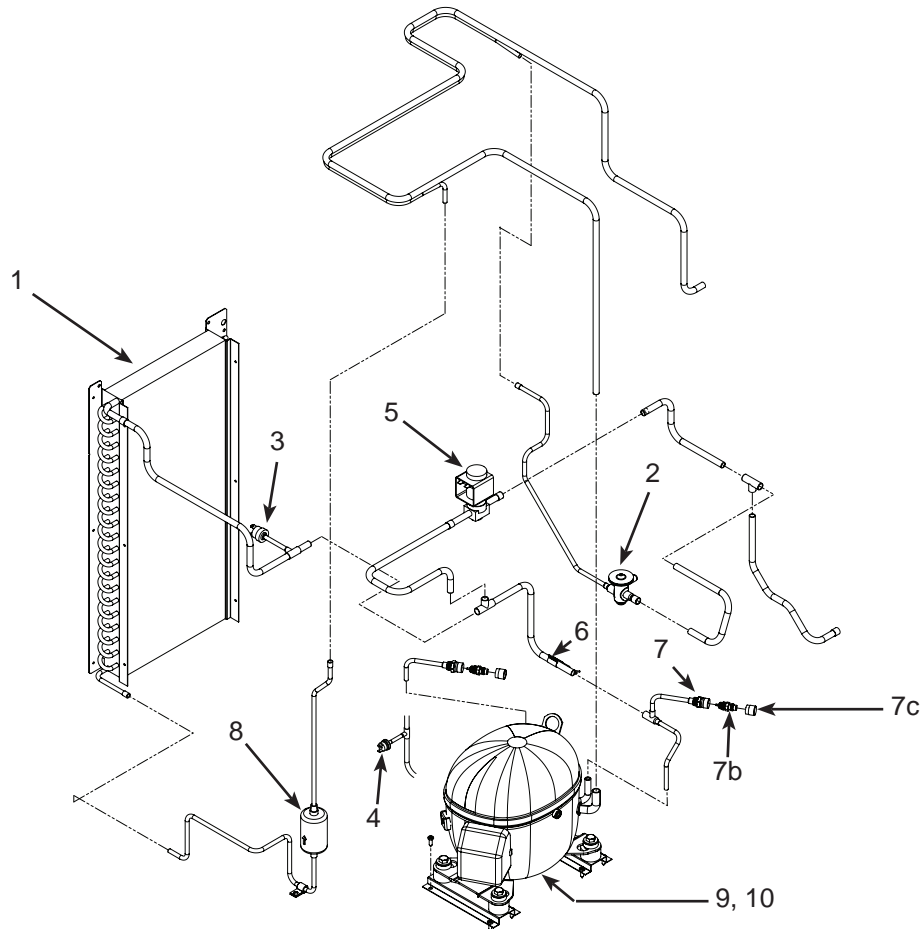

Item Number	Part Number	Description	Item Number	Part Number	Description
1	18-8890-01	Condenser, AC, 0330	5	11-0493-02	Hot gas valve, 115 volt
	18-8920-01	Cond, AC, C0530 - A series		12-2719-21	115 volt coil
	18-8935-01	Cond, AC, 0530 - B - D series		11-0493-01	Hot gas valve, 230 volt
	18-8896-01	Condenser, AC, 0630		12-2719-22	230 volt coil
	18-8895-01	Condenser, AC, 0830, 1030	6	12-2733-30	HGV rebuild kit
2	16-1182-02	TXV, C0530 A or B Series	6	11-0515-21	Thermistor
	16-1184-01	TXV, 0530 C, D, or E series	7	16-1137-01	3/8" Valve body
	16-1182-01	TXV, 0630	7a	16-1138-01	1/4" Valve body
	16-1183-02	TXV, 0330	7b	16-1139-01	Core
	16-1142-01	TXV, 0830, 1030	7c	16-1140-01	Cap
	19-0599-06	Insulation, TXV	8	02-3319-01	Dryer 0330 thru 0630
3	11-0566-21	Fan cycle pressure sw.	8	02-3319-02	Dryer 0830 & 1030
4	11-0501-05	Hi pressure cut out, 0330 A-B series, 0530 A-B series and 0630	9	see page 17	Compressors
			10	see page 17	Compressor mounting hdw
			11	11-0515-21	Temp sensor set
					Access valve changed 4-08. Prior valve:
				16-0832-20	Access valve
				16-0832-03	Port cap
				16-0832-02	Stem cap

# C0330, C0530, C0630, C0830, C1030 Service Parts

## Fan and Condenser Area C0330

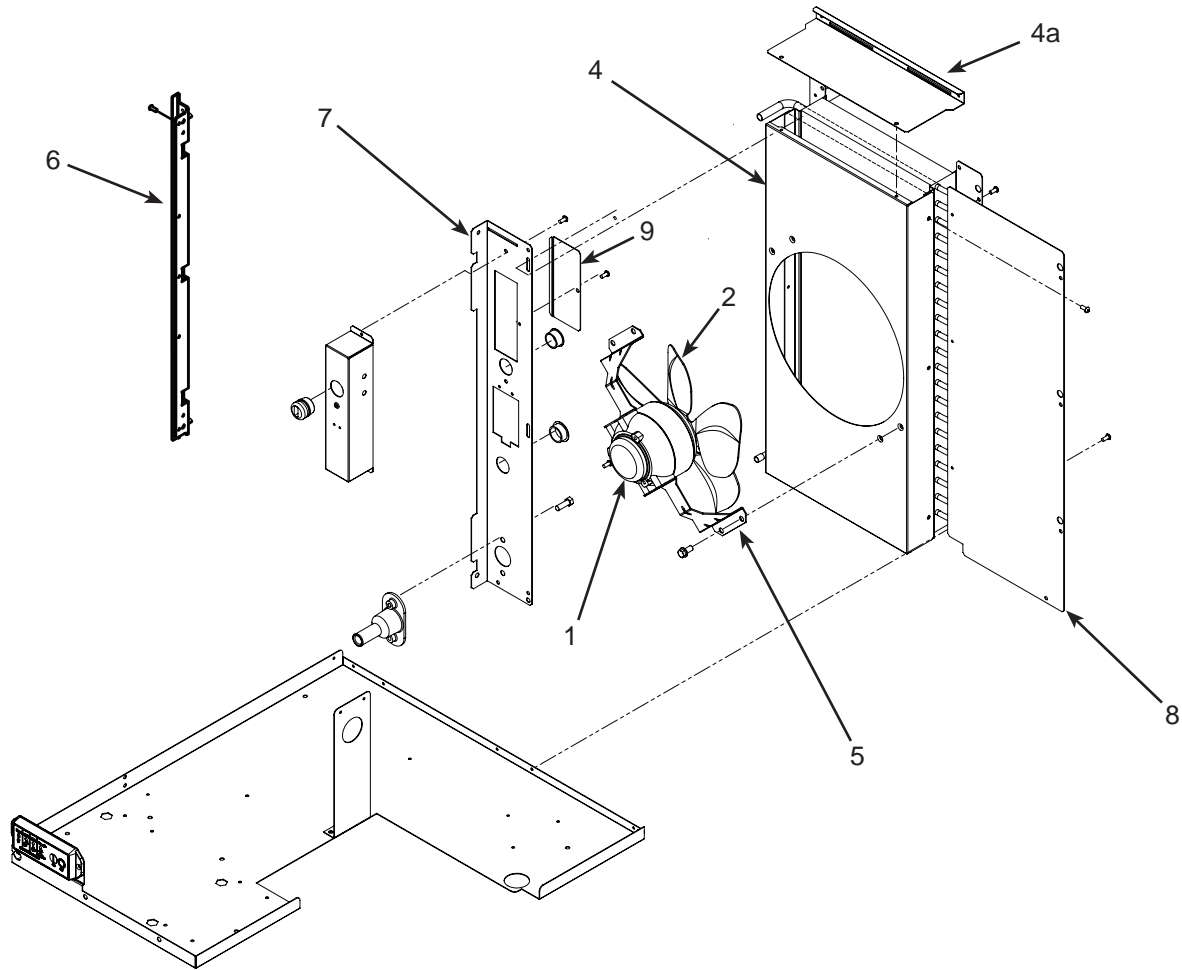

Item Number	Part Number	Description	Item Number	Part Number	Description
1	<a href="#">12-1681-23</a>	Fan motor, 0330, 115 volt	10		
	<a href="#">12-1681-04</a>	Fan motor, 0330, 230 volt			
2	<a href="#">18-8836-01</a>	Fan blade, 0330			
3	<a href="#">02-3692-21</a>	Drain adapter - also for WC and RC			
4	<a href="#">A38841-001</a>	Fan shroud, 330 A Series			
	<a href="#">A39350-001</a>	Fan shroud, 0330 B,C,D,E Series			
4a	<a href="#">A39593-001</a>	Fan shroud top, B,C,D,E series			
5	<a href="#">A38480-001</a>	Fan motor bracket, 0330			
6	<a href="#">02-4067-02</a>	Side panel support, 0330, 0530, 0630 A Series Only			
7	<a href="#">A38791-001</a>	Utility channel, (Air Cooled) A series			
	<a href="#">A40418-001</a>	Utility channel, (Air Cooled) B,C,D,E			
8	<a href="#">A39606-001</a>	Back panel, B,C,D,E series			
9	<a href="#">A38548-002</a>	Junction box cover			

# C0330, C0530, C0630, C0830, C1030 Service Parts

## Fan and Condenser Area C0530 thru C0830

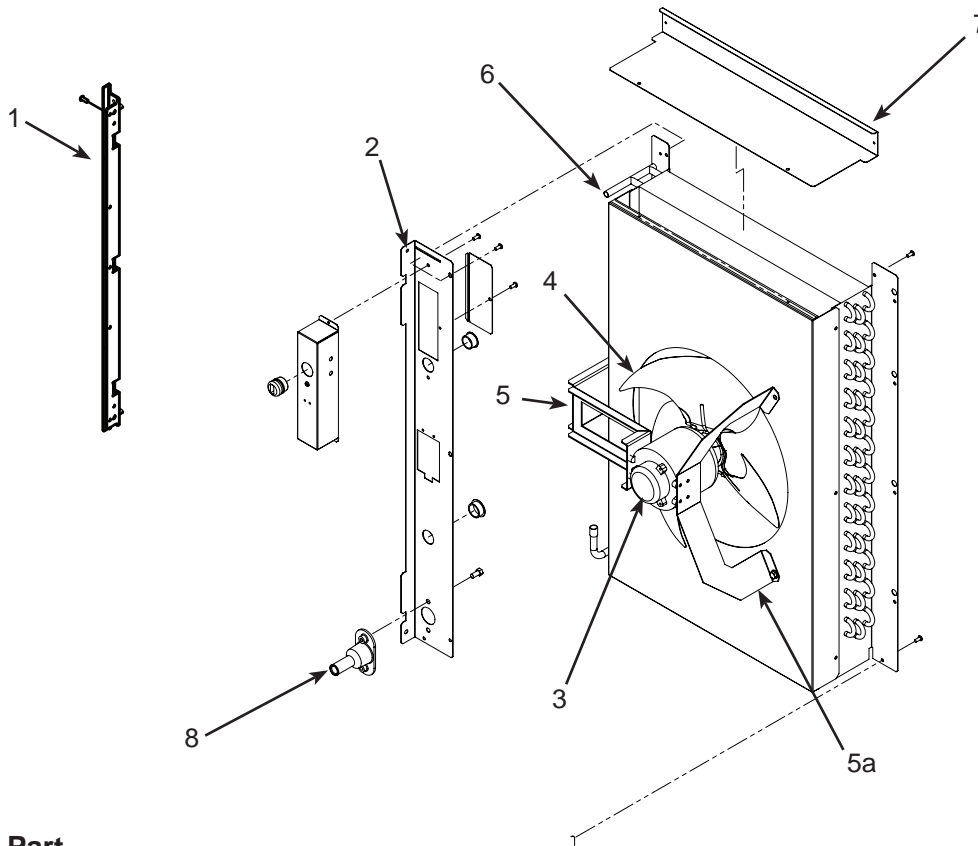

Item Number	Part Number	Description	Voltage/Hz	Fits Model	Fits series
1	02-4067-02	Side panel support		C0330-0630	A only
	02-4067-04	Side panel support		C0830-1030	A only
2	A38791-001	Utility channel		C0330-0630	A
	A40420-001	Utility channel		C0830-1030	B-D
3	18-8926-01	Fan motor	115/60	C0530-1	A-D
	18-8927-01	Fan motor	208-230/60	C0530, C0630, C0830-32,-3	A-D
4	18-8882-01	Fan blade		C0530, C0630, C0830	A-D
5	A38554-001	Fan motor bracket		C0530, C0630, C0830	A-C*
	A40156-001	Fan motor bracket, right		C0530, C0630, C0830	C**-D
5a	A40148-001	Fan motor bracket, left		C0530, C0630, C0830,	C**-D
6	A39607-001	Fan shroud		C0530, C0630	A-C*
	A36603-001	Fan shroud		C0830	A-C*
	A40146-001	Fan shroud		C0530, C0630	C**-D
	A40147-001	Fan shroud		C0830	C**-D
7	A39608-001	Shroud top		C0530, C0630	B-D
	A39601-001	Shroud top		C0830	B-D
8	02-3692-21	Drain adapter		all	

\* Up to serial number 13031320011477. Fan blade flush with end of motor shaft.

\*\* Beginning serial number 13031320011477. Then fan blade is .25" from end of shaft.

# C0330, C0530, C0630, C0830, C1030 Service Parts

## Fan and Condenser Area C1030

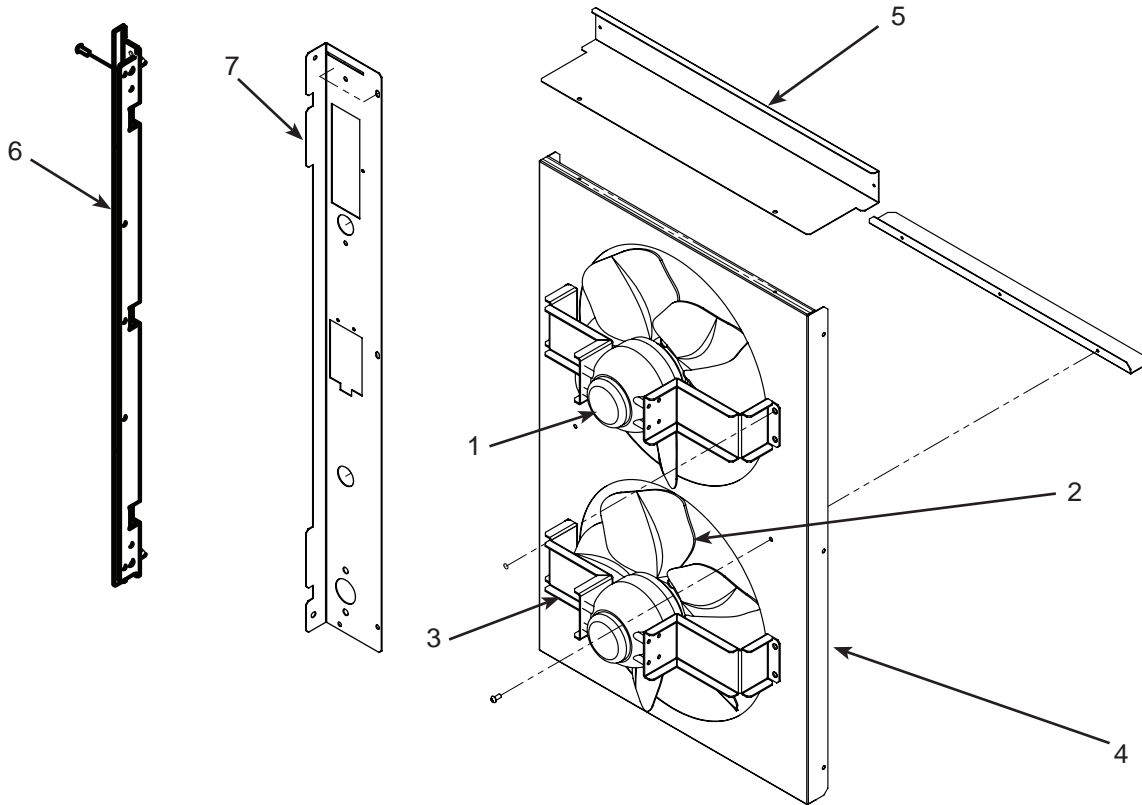

Item Number	Part Number	Description	Voltage/Hz	Fits Model	Fits series
1	<a href="#">18-8899-01</a>	Fan motor	208-230/60	C1030-32, -3	A-D
	<a href="#">18-8899-06</a>	Fan motor	230/50	C1030-6	A-D
2	<a href="#">18-8900-01</a>	Fan blade	-	C1030	A-D
3	<a href="#">A38655-001</a>	Fan motor bracket		C1030	A-D
4	<a href="#">A38624-001</a>	Fan shroud		C1030	A-D
5	<a href="#">A39610-001</a>	Fan shroud top		C1030	B-D
6	<a href="#">02-4067-04</a>	Side panel support		C0830-1030	A only
7	<a href="#">A40420-001</a>	Utility channel		C0830-1030	B-D

# C0330, C0530, C0630, C0830, C1030 Service Parts

## Water Cooled Refrigeration System

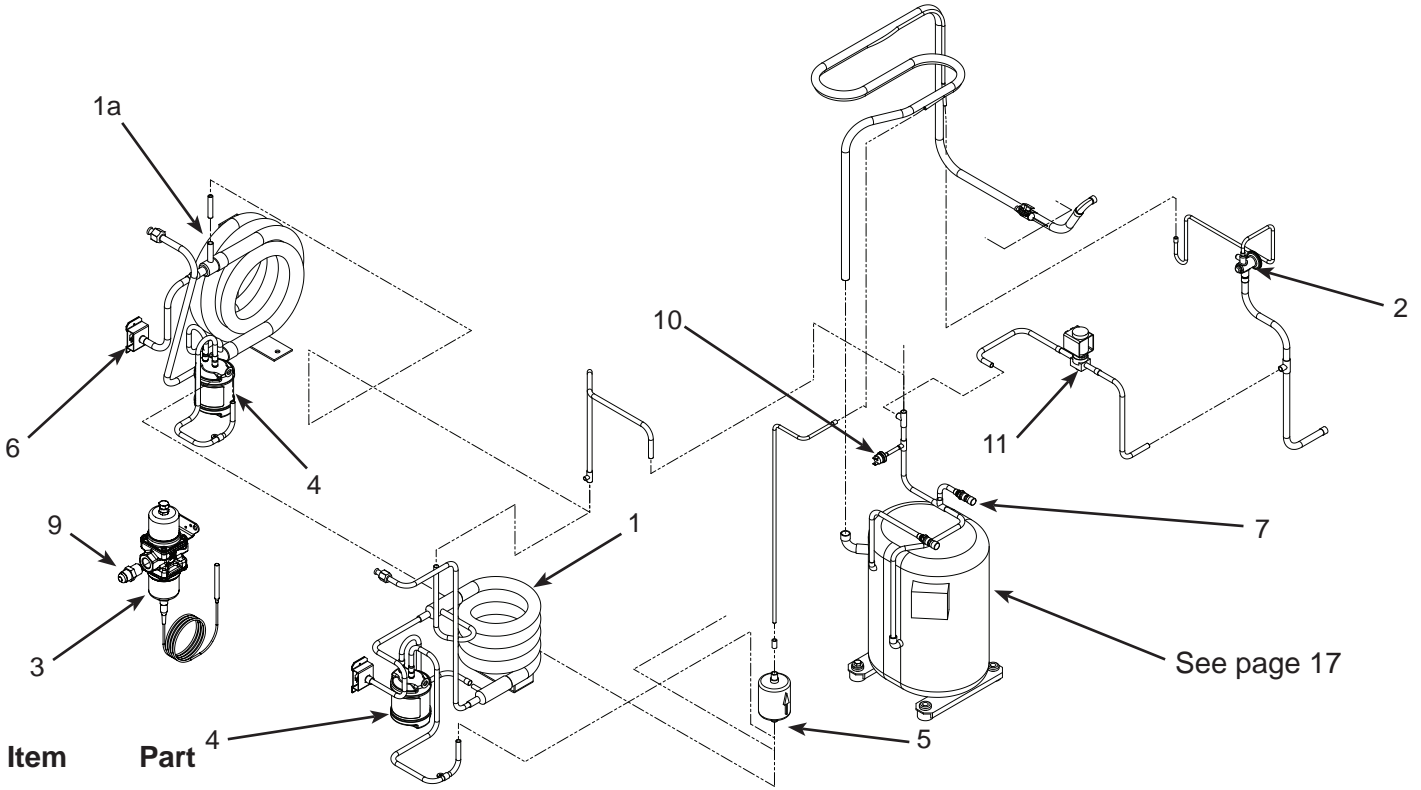

Item Number	Part Number	Description
1	<a href="#">18-8871-21</a>	Condenser, WC, C0330, C0530, C0630, C0830
1a	<a href="#">18-8893-21</a>	Condenser, WC, C1030
2	<a href="#">16-1182-02</a>	TXV, C0530 A or B series
	<a href="#">16-1184-01</a>	TXV, C0530 C series
	<a href="#">16-1182-01</a>	TXV, C0630
	<a href="#">16-1183-02</a>	TXV, C0330
	<a href="#">16-1142-01</a>	TXV, C0830, C1030
3	<a href="#">19-0599-06</a>	Insulation TXV
	<a href="#">11-0608-21</a>	Water regulating valve
4	<a href="#">16-0874-01</a>	Receiver, C0830, C1030
5	<a href="#">02-3319-01</a>	Dryer, C0330 thru C0630
	<a href="#">02-3319-02</a>	Dryer, C0830 - C1030
6	<a href="#">A31828-002</a>	Condenser drain
7	<a href="#">16-1137-01</a>	Valve body 3/8"
7a	<a href="#">16-1138-01</a>	Valve body 1/4"
8	<a href="#">16-1063-01</a>	Strainer no longer used
9	<a href="#">16-0355-00</a>	Half union
10	<a href="#">11-0501-21</a>	High pressure cut out
10	<a href="#">11-0501-21</a>	High pressure cut out
11	<a href="#">11-0493-02</a>	Hot gas valve, 115 volt
	<a href="#">11-0493-01</a>	Hot gas valve, 230 volt
	<a href="#">12-2719-22</a>	230 volt coil
	<a href="#">12-2733-30</a>	HGV rebuild kit
12	<a href="#">16-1063-01</a>	Strainer no longer used
	<a href="#">A38634-001</a>	Back pnl, WC - A Series 23"
	<a href="#">A38625-001</a>	Back pnl, WC - A Series 29"
	<a href="#">A39561-001</a>	Back pnl, WC - B/C series 23"
	<a href="#">A39573-001</a>	Back pnl, WC - B Series 29"
	<a href="#">A40417-001</a>	Back pnl, WC - D series 23"
	<a href="#">A40515-001</a>	Back pnl, WC - E series 23"
	<a href="#">A40654-001</a>	back pnl. cover WC - E series
	<a href="#">A40419-001</a>	Back pnl, WC - D series 29"
	<a href="#">A40522-001</a>	Back pnl, WC - E series 29"
	<a href="#">16-0832-20</a>	Access valve (for hex wrench)
	<a href="#">16-0832-03</a>	Port cap
	<a href="#">16-0832-02</a>	Stem cap
	<a href="#">16-1139-01</a>	Core (for item #7)
	<a href="#">16-1140-01</a>	Cap (for item #7)

Not Illustrated

# C0330, C0530, C0630, C0830, C1030 Service Parts

## Remote Refrigeration System

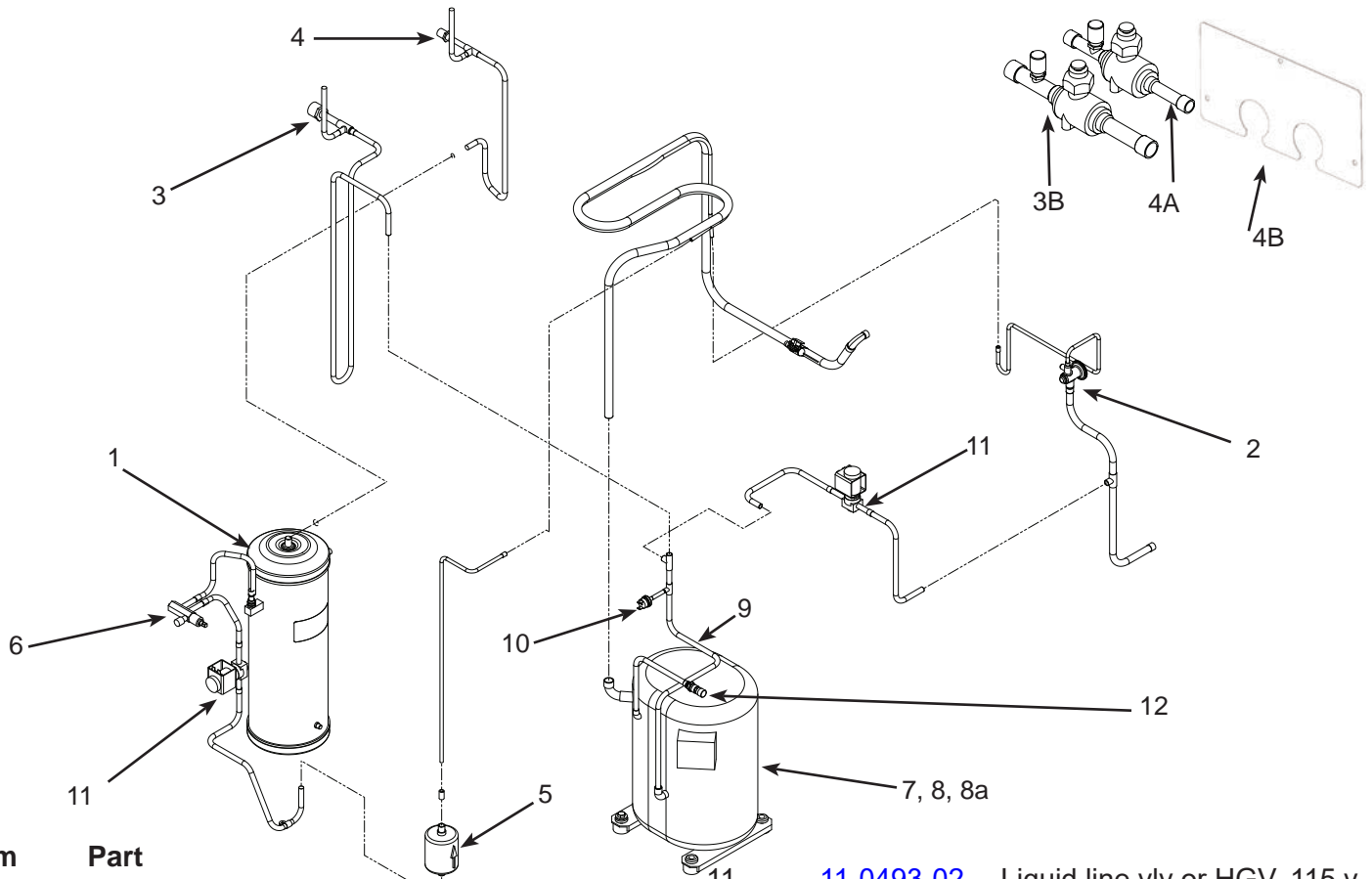

Item Number	Part Number	Description
1	16-1176-01	Receiver, C0530, C0630
	16-1175-01	Receiver, C0830, C1030
2	16-1182-02	TXV, C0530 A or B series
	16-1184-01	TXV, C0530 C series
	16-1182-01	TXV, C0630
	16-1142-01	TXV, C0830, C1030
	19-0599-06	Insulation, TXV
3	16-0850-01	Discharge quick connect
3A	16-1208-02	Discharge Isolation valve E Series
4	16-0850-03	Liquid quick connect
4A	16-1208-01	Liquid Isolation valve E Series
4B	A40508-001	Cover Isolation valves E Series
5	02-3319-02	Drier
6	16-1030-01	Liquid line access valve
7	see page 17	Compressors
8	see page 17	Compressor mounting hdw
8a	see page 17	Crankcase heater
9	11-0515-21	Thermistor
10	11-0501-22	High pressure cut out
	11	11-0493-02 Liquid line vlv or HGV, 115 v
		11-0493-01 Liquid line vlv or HGV, 230 v
	12	16-1137-01 3/8" Valve body
	12a	16-1138-01 1/4 Valve body
		16-1140-01 Cap (for #12)
		16-1139-01 Core (for #12)
		16-1063-01 Strainer - no longer used
		A37211-001 Top receiver bracket
		A37212-001 Bottom receiver bracket
		A38664-001 Back pnl, RC - A series 23"
		A38665-001 Back pnl, RC - A series 29"
		A39561-001 Bck pnl, RC - B/C series 23"
		A39573-001 Back pnl, RC - B Series 29"
		A40416-001 Back pnl, RC - D series, 23"
		A40419-001 Back pnl, RC - D series, 29"
		A40522-001 Back pnl. RC/WC - E Series. 29"
		A40507-001 Isolation Valve bracket E Series

Not Illustrated

# C0330, C0530, C0630, C0830, C1030 Service Parts

## Electrical and Control Box

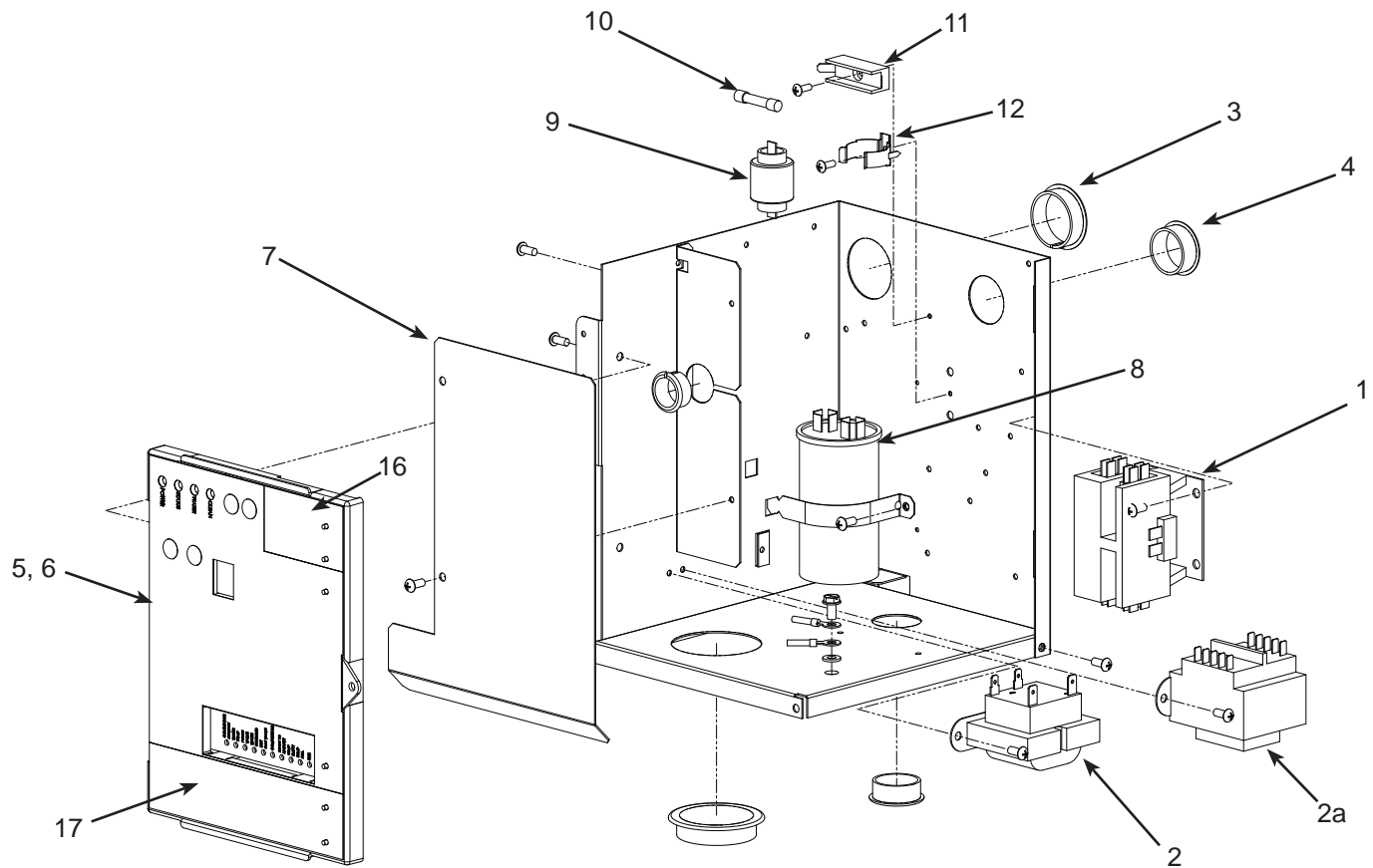

Item Number	Part Number	Description
1	12-2469-03	Contactor, 115 volt
	12-2469-02	Contactor, 230, single ph
	12-2533-02	Contactor, three phase
2	12-2924-01	Transformer, 115 volt
	12-2924-02	Transformer, 230 volt
2a	12-2639-01	Transformer, 50 Hz
3	12-1213-11	Snap bushing
4	12-1213-15	Snap bushing
5	11-0550-28	Service controller, thru C series
	11-0621-21	Service controller, fits all Prodigy cubers
6	02-4076-01	Control box door
	02-4189-01	Overlay label
7	A39216-001	Barrier
8		see next page Run capacitor
9		see next page PTCR -
10	12-2686-01	Fuse, 50 Hz only
11	12-2687-01	Fuse holder
12	18-8835-02	Bracket
Wiring Harnesses (not illustrated)		
13	12-2931-01	Power harness, A & W
	12-2931-02	Power harness, Remote
Power harness connects to J1 on controller		
14	12-2932-01	Hi voltage harness, A & W
	12-2933-01	Hi voltage harness, Rem
	12-3064-01	Hi voltage, 50 Hz A & W
Hi voltage harness has the 8 pin connector		
15	12-2928-02	WLS harness
16	KVS	Vari-smart ice level control
17	KSBU-N	
Items 16 and 17 standard on CB models.		

# C0330, C0530, C0630, C0830, C1030 Service Parts

## Compressors

Model	Series	Electrical	Compressor	Overload	Run Capacitor	PTCR
C0330-1	A or B	115/60/1	18-8897-21	18-8897-23*	18-1902-69*	18-8835-01*
C0330-6	A or B	230/50	18-8897-26	18-8897-28*	18-1902-57*	18-8835-01*
C0330-32	A or B	208-230/60/1	18-8897-22	18-8897-27*	18-1902-57*	18-8835-01*
C0330-1	C-E	115/60/1	18-8948-21	18-8948-50*	18-1902-64*	18-8835-01*
C0330-6	C-E	230/50	18-8948-22	18-8948-51*	18-1902-65*	18-8835-01*
C0330-32	C-E	208-230/60/1	18-8948-23	18-8948-51*	18-1902-30*	18-8835-01*
C0530-1	A or B	115/60/1	18-8921-21	18-8921-23*	18-1902-45*	18-8835-01*
C0530-6	A or B	230/50	18-8921-26	18-8774-27*	18-1902-68*	18-8835-01*
C0530-32	A or B	208-230/60/1	18-8921-22	18-8774-28*	18-1902-68*	18-8835-01*
C0530-1	C-E	115/60/1	18-8948-21	18-8948-50*	18-1902-64*	18-8835-01*
C0530-6	C-E	230/50	18-8948-22	18-8948-51*	18-1902-65*	18-8835-01*
C0530-32	C-E	208-230/60/1	18-8948-23	18-8948-51*	18-1902-30*	18-8835-01*
C0630-32	A-D	208-230/60/1	18-8922-22	18-8922-27*	18-1902-57*	18-8835-01*
C0630-32	E	208-230/60/1	18-8955-22	internal	18-1902-67*	18-8835-01*
C0630-6	A-D	230/50	18-8922-26	internal	18-1902-71*	18-8835-01*
C0630-6	E	230/50	18-8990-26	internal	18-1902-63*	18-8835-01*
C0830-32	all	208-230/60/1	18-8813-23	internal	18-1902-69*	18-8835-01*
C0830-6	all	230/50	18-8813-27	internal	18-1902-69*	18-8835-01*
C0830-3	all	208-230/60/3	18-8813-25	internal	-	-
C0830-63	B	440/50/3	18-8813-08	internal	-	-
C1030-32	A-D,F	208-230/60/1	18-8726-23	internal	18-1902-69*	18-8835-01*
C1030-32	E	208-230/60/1	18-8980-21	internal	18-1902-70*	18-8835-01*
C1030-6	All	230/50	18-8726-27	internal	18-1902-69*	18-8835-01*
C1030-3	A-D,F	208-230/60/3	18-8726-25	internal	-	-
C1030-3	E	208-230/60/3	18-8980-22	internal	-	-
CA1030-6	B	230/50/1	18-8749-27	internal	18-1902-70*	18-8835-01*

\* Replacement compressors include selected components and a filter dryer. They may also include other components used only on other models. CS type compressors include fittings to adapt to prior tubing sizes.

# C0330, C0530, C0630, C0830, C1030 Service Parts

## Compressor Mounting Hardware / Crankcase Heater

Model	Series	Bolt	Washer	Grommet	Sleeve
C/CB 0330	all	<a href="#">03-1405-20</a>	<a href="#">03-1407-07</a>	<a href="#">18-4700-28</a>	<a href="#">18-0108-41</a>
C0530	A or B	<a href="#">03-1405-20</a>	<a href="#">03-1407-07</a>	<a href="#">18-4700-28</a>	<a href="#">18-0108-41</a>
C/CB 0330 or 0530	C,D,E	<a href="#">03-1405-20</a>	<a href="#">03-1407-07</a>	<a href="#">18-2200-28</a>	<a href="#">18-2200-27</a>
C/CB 0630	all	<a href="#">03-1405-20</a>	<a href="#">03-1407-07</a>	<a href="#">18-4700-28</a>	<a href="#">18-0108-41</a>
C0630	E	<a href="#">03-1405-20</a>	<a href="#">03-1407-07</a>	<a href="#">18-2200-28</a>	<a href="#">18-2200-27</a>
C/CB 0830 or 1030	all	<a href="#">03-1405-20</a>	<a href="#">03-1407-07</a>	<a href="#">18-2300-27</a>	<a href="#">18-2300-26</a>

Model		Crankcase heater	
C0530R	A or B Series	<a href="#">12-2942-01</a>	
C0530R	C Series	<a href="#">12-3043-01</a>	
C0630R	A-D	<a href="#">12-2942-02</a>	
C0630R	E	<a href="#">12-3043-02</a>	
C0830R or C1030R	A-D	<a href="#">18-2308-01</a> internal	<a href="#">12-3043-03</a> * external
C1030R	E	<a href="#">12-1868-05</a> external	

\* Replacement compressors include selected components and a filter dryer. They may also include other components used only on other models. CS type compressors include fittings to adapt to prior tubing sizes.

# C0330, C0530, C0630, C0830, C1030 Service Parts

## Remote Condenser, ERC111, ERC211 and ERC311

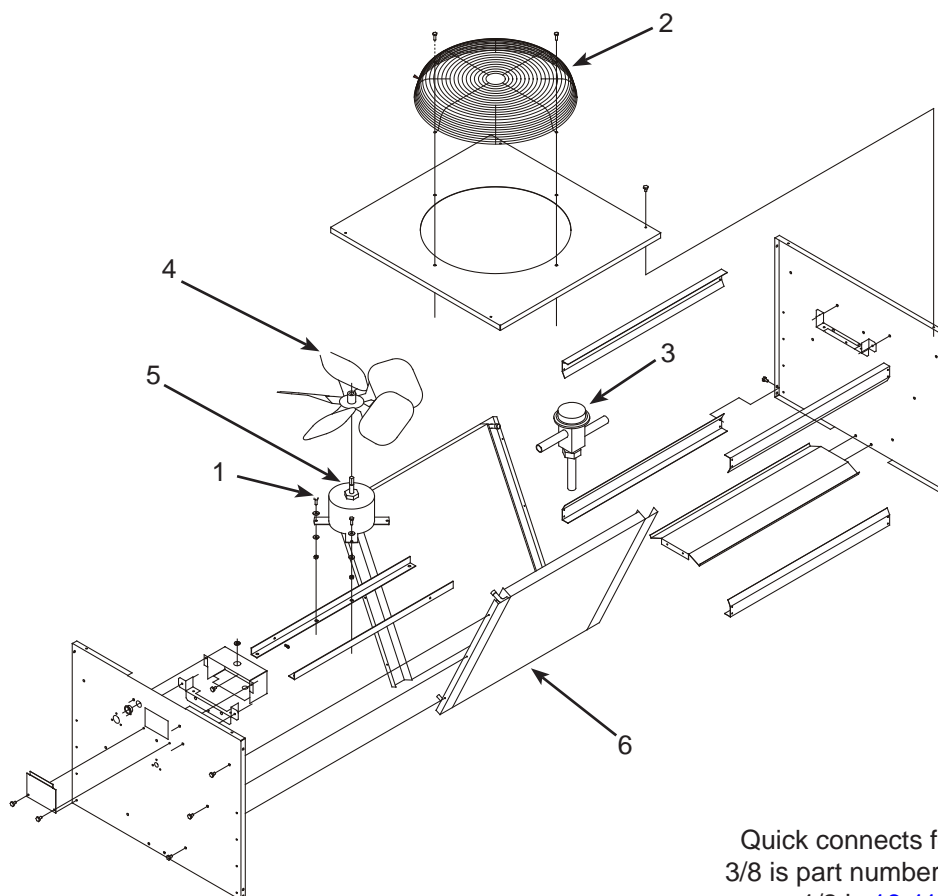

Quick connects for line sets:  
 3/8 is part number [16-1100-08](#);  
 1/2 is [16-1100-09](#).

Item Number	Part Number	Description
1	<a href="#">03-1405-08</a>	Screw
2	<a href="#">02-3575-01</a>	Fan guard
3	<a href="#">11-0422-22</a>	Headmaster
4	<a href="#">18-8816-01</a>	Fan blade
5	<a href="#">12-2651-01</a>	Fan motor - 230 volt (ERC311)
	<a href="#">12-2651-02</a>	Fan motor - 115 volt (ERC111 and ERC211)
6	<a href="#">18-8815-01</a>	Coil, ERC111
	<a href="#">18-8827-01</a>	Coil, ERC311

Not Shown:

<a href="#">A37169-001</a>	Leg
<a href="#">A37170-001</a>	Leg brace
<a href="#">03-1645-01</a>	Screw for legs
<a href="#">16-0850-01</a>	Quick connect, discharge
<a href="#">16-0850-03</a>	Quick connect, liquid