

Undercounter Freezer Manual

Model – USCF-27

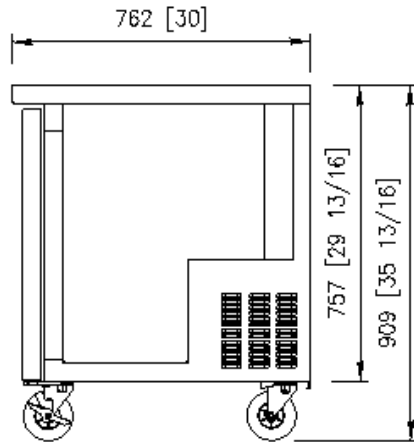
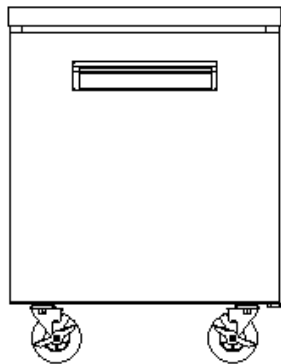
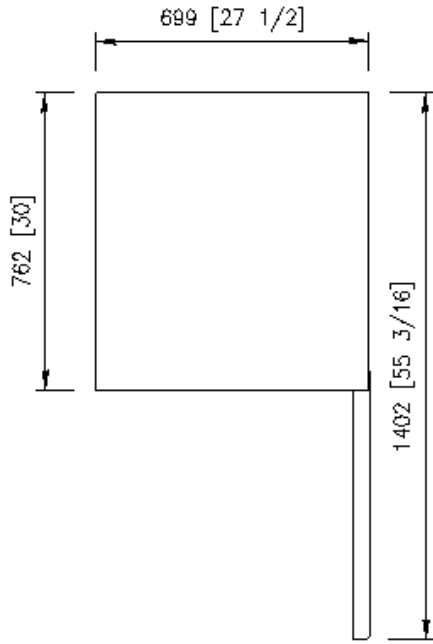

1. Technical Specifications		
Amp	115V	5.3A
Connection		15 amp plug
Refrigerant	Name	R134a
	Q'ty (oz)	3.9
	Q'ty (gram)	110
	HP	3/8 HP
Compressor	Samsung	SK1A1C-L2W
2. Function Specifications		
Temp Range	°F	Below 0°F
Capacity	Cubic Feet	7
Climate Class		N
Max Ambient Temp	°F	89.6°F
Min Ambient Temp	°F	59°F
Castors	5"	4EA
Shelves		2EA
Doors		1EA
Exterior Finish		Stainless Steel
Interior Finish		Stainless Steel
3. Sizes		
Exterior Dimensions	Width(Inches)	27 1/2 inch
	Depth (Inches)	30 inch
	Height (Inches)	35 13/16 inch
Weight	LBS	150 lb

Model – USCF-36

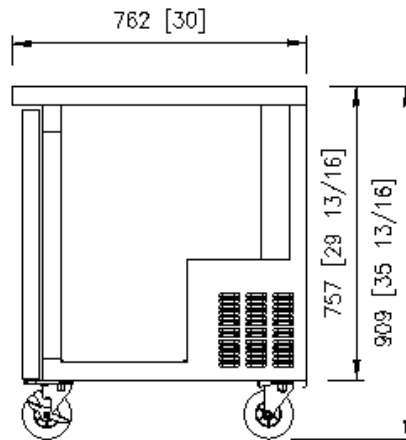
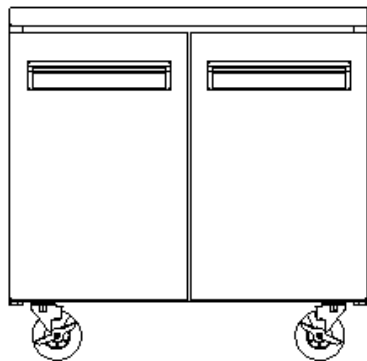
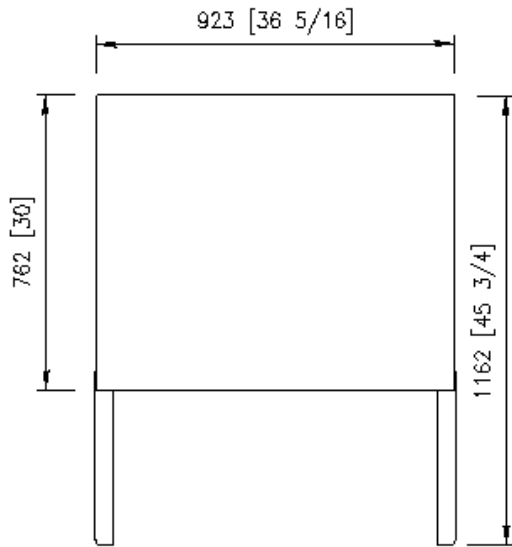

1. Technical Specifications

Amp	115V	7.5A
Connection		15 amp plug
Refrigerant	Name	R404a
	Q'ty (oz)	4.2
	Q'ty (gram)	120
Compressor	HP	1/2 HP
	Danfoss	SC12CLX.2

2. Function Specifications

Temp Range	°F	Below 0°F
Capacity	Cubic Feet	9
Climate Class		N
Max Ambient Temp	°F	89.6°F
Min Ambient Temp	°F	59°F
Castors	5"	4EA
Shelves		4EA
Doors		2EA
Exterior Finish		Stainless Steel
Interior Finish		Stainless Steel

3. Sizes

Exterior Dimensions	Width(Inches)	36 5/16inch
	Depth (Inches)	30 inch
	Height (Inches)	35 13/16 inch
Weight	LBS	187 lb

Model – USCF-48

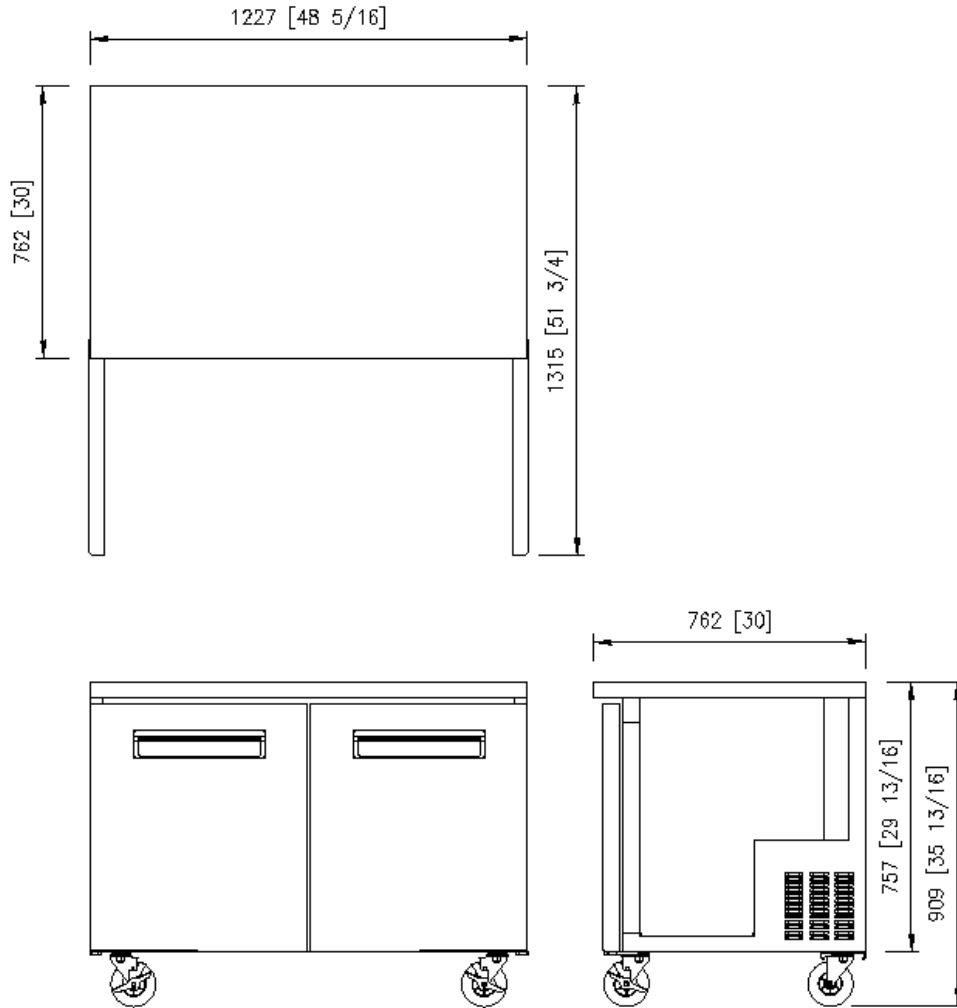

1. Technical Specifications		
Amp	115V	7.5A
Connection		15 amp plug
Refrigerant	Name	R404a
	Q'ty (oz)	10.2
	Q'ty (gram)	290
	HP	1/2 HP
Compressor	Danfoss	SC12CLX.2
2. Function Specifications		
Temp Range	°F	Below 0°F
Capacity	Cubic Feet	12
Climature Class		N
Max Ambient Temp	°F	89.6°F
Min Ambient Temp	°F	59°F
Castors	5"	4EA
Shelves		4EA
Doors		2EA
Exterior Finish		Stainless Steel
Interior Finish		Stainless Steel
3. Sizes		
Exterior Dimensions	Width(Inches)	48 5/16 inch
	Depth (Inches)	30 inch
	Height (Inches)	35 13/16 inch
Weight	LBS	209 lb

■ Model – USCF-60

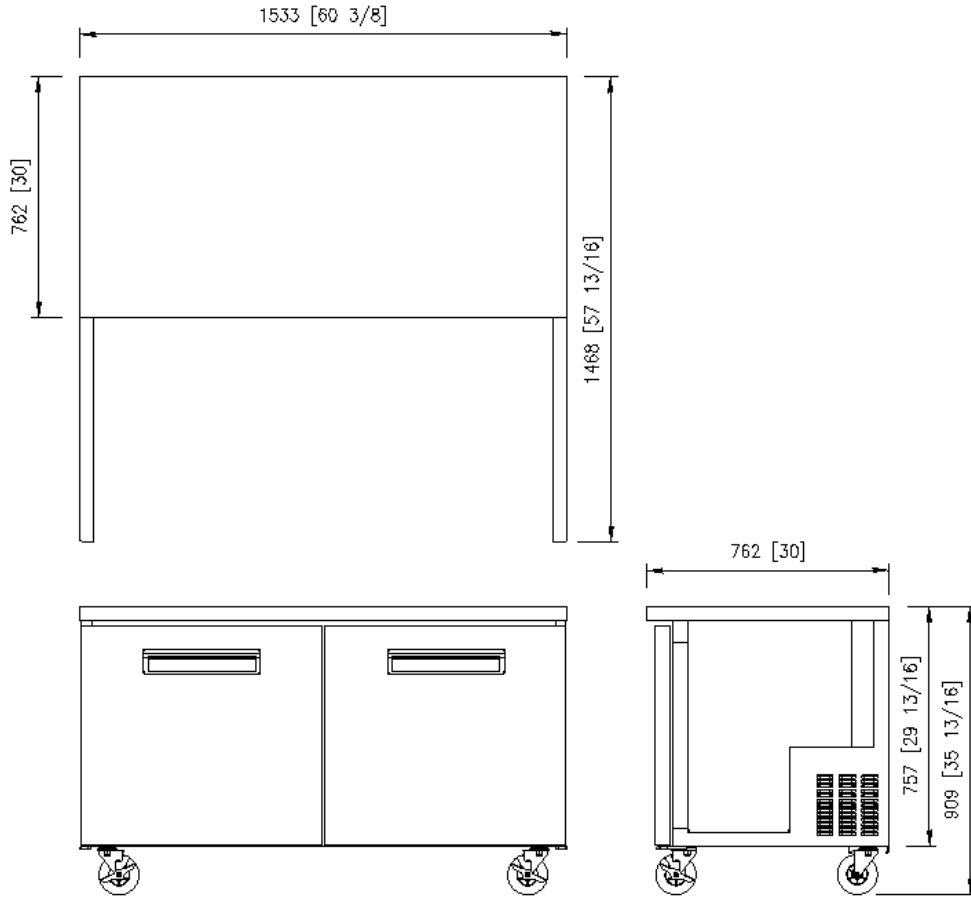

1. Technical Specifications

Amp	115V	7.5A
Connection		15 amp plug
Refrigerant	Name	R404a
	Q'ty (oz)	10.9
	Q'ty (gram)	310
	HP	1/2 HP
Compressor	Danfoss	SC12CLX.2

2. Function Specifications

Temp Range	°F	Below 0°F
Capacity	Cubic Feet	16
Climate Class		N
Max Ambient Temp	°F	89.6°F
Min Ambient Temp	°F	59°F
Castors	5"	4EA
Shelves		4EA
Doors		2EA
Exterior Finish		Stainless Steel
Interior Finish		Stainless Steel

3. Sizes

Exterior Dimensions	Width(Inches)	60 3/8inch
	Depth (Inches)	30 inch
	Height (Inches)	35 13/16 inch
	Weight	LBS

Model – USCF-72

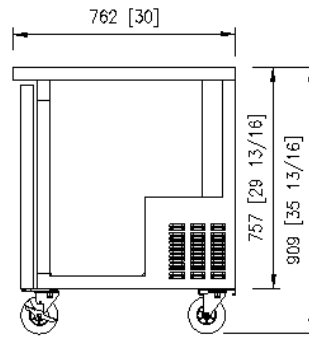
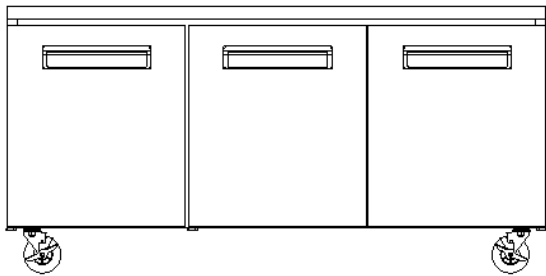
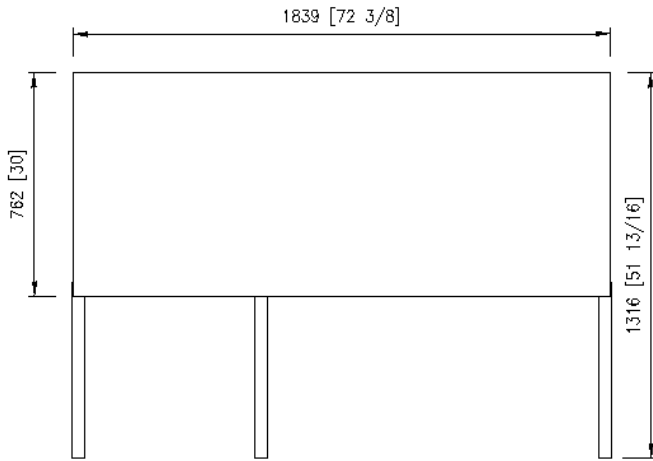

1. Technical Specifications

Amp	115V	7.8A
Connection		15 amp plug
Refrigerant	Name	R404a
	Q'ty (oz)	12
	Q'ty (gram)	340
	HP	1/2 HP
Compressor	Danfoss	SC12CLX.2

2. Function Specifications

Temp Range	°F	Below 0°F
Capacity	Cubic Feet	20
Climate Class		N
Max Ambient Temp	°F	89.6°F
Min Ambient Temp	°F	59°F
Castors	5"	4EA
Shelves		6EA
Doors		3EA
Exterior Finish		Stainless Steel
Interior Finish		Stainless Steel

3. Sizes

Exterior Dimensions	Width(Inches)	72 3/8inch
	Depth (Inches)	30 inch
	Height (Inches)	35 13/16 inch
Weight	LBS	280 lb

■ Cabinet - 1

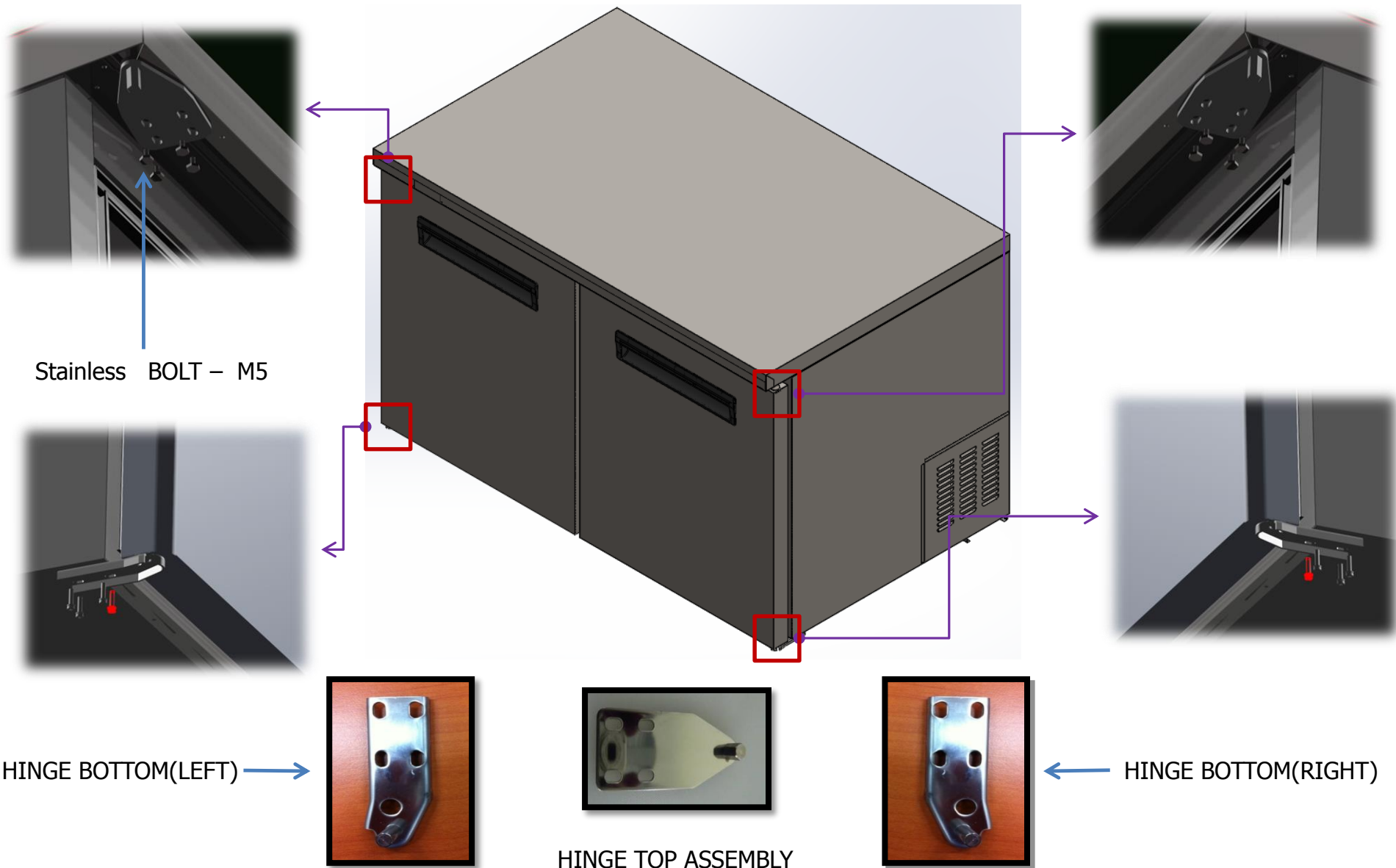

■ DOOR

HINGE SHAFT

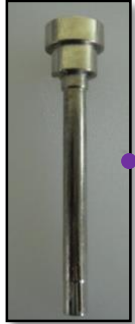

SPRING LEFT

DOOR GASKET

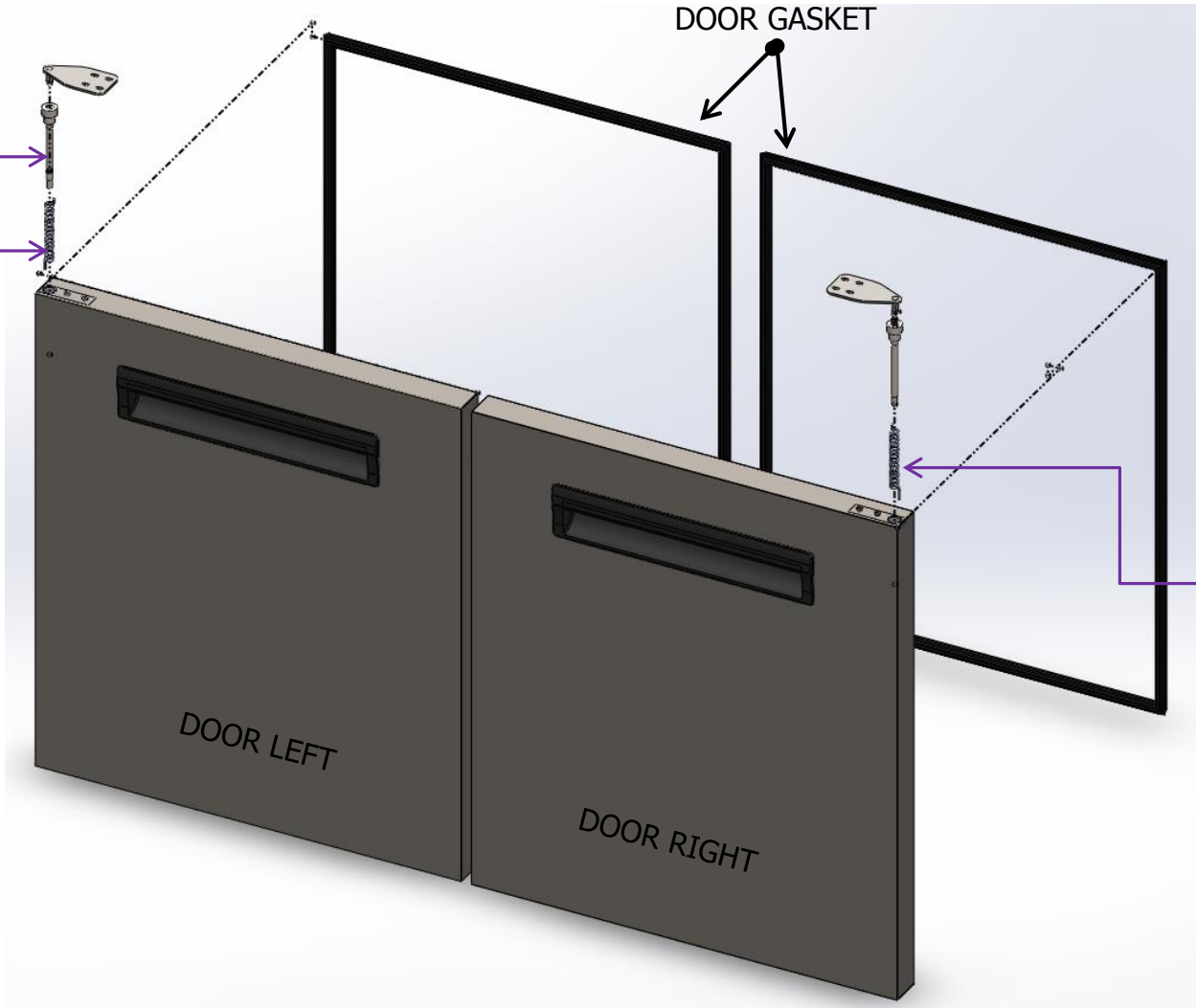

SPRING RIGHT



■ Cabinet - 2

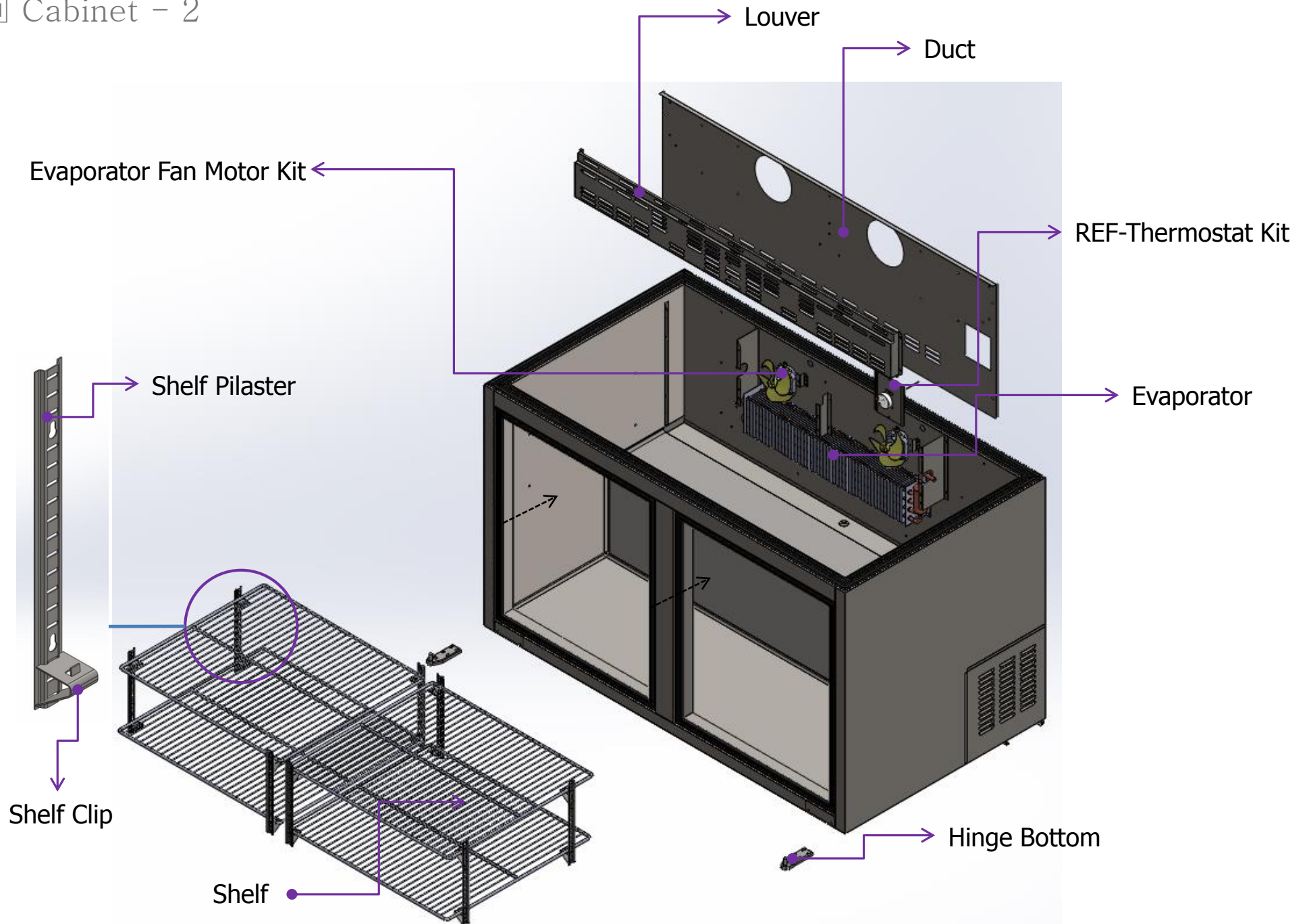

■ Machine room (Freezer)-1

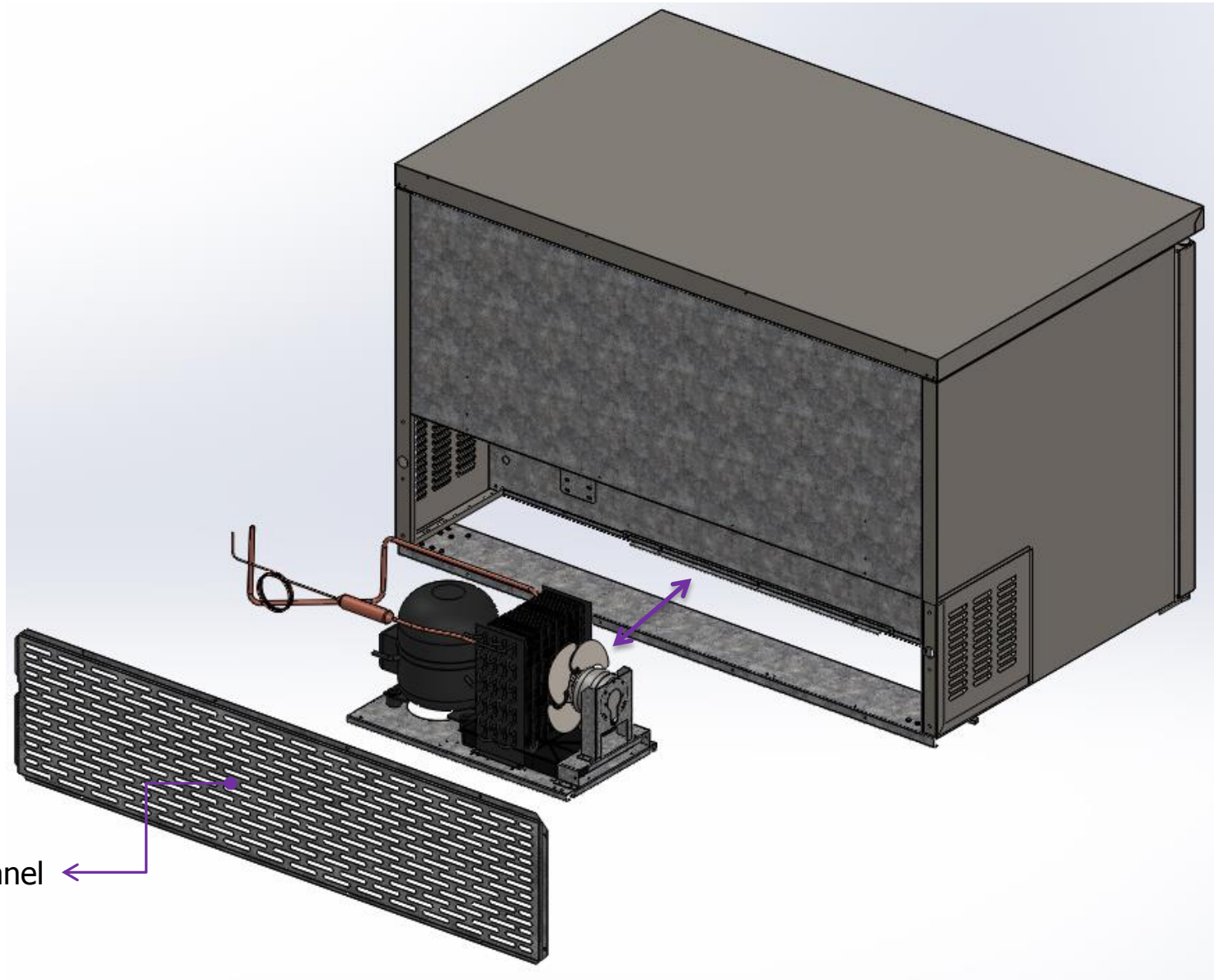

Back Panel

Machine room (Freezer)-2
Condensing Unit Disassembly - USCF-27 / 36

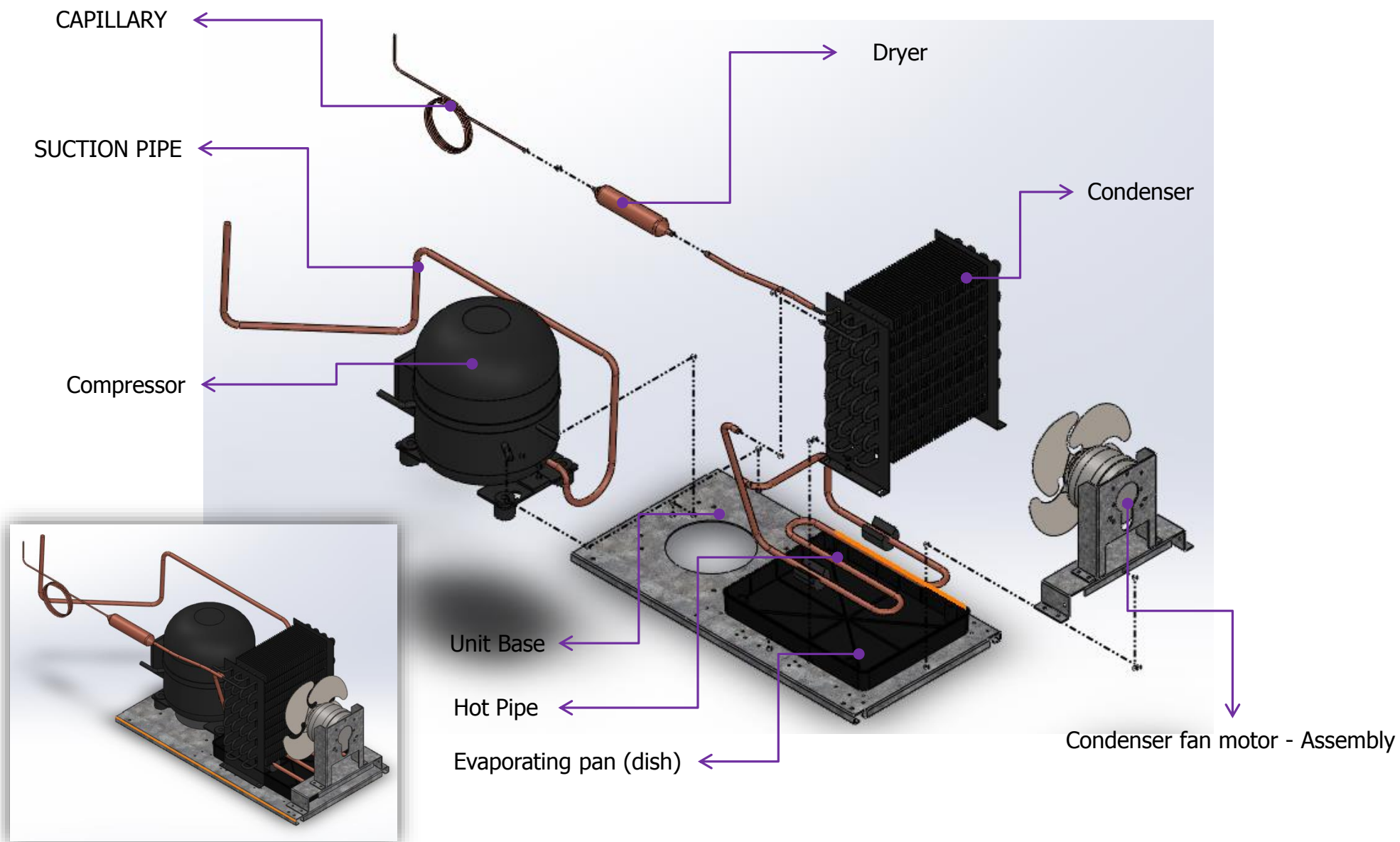

Machine room (Freezer)-3

Condensing Unit Disassembly - USCF-48 / 60 / 72

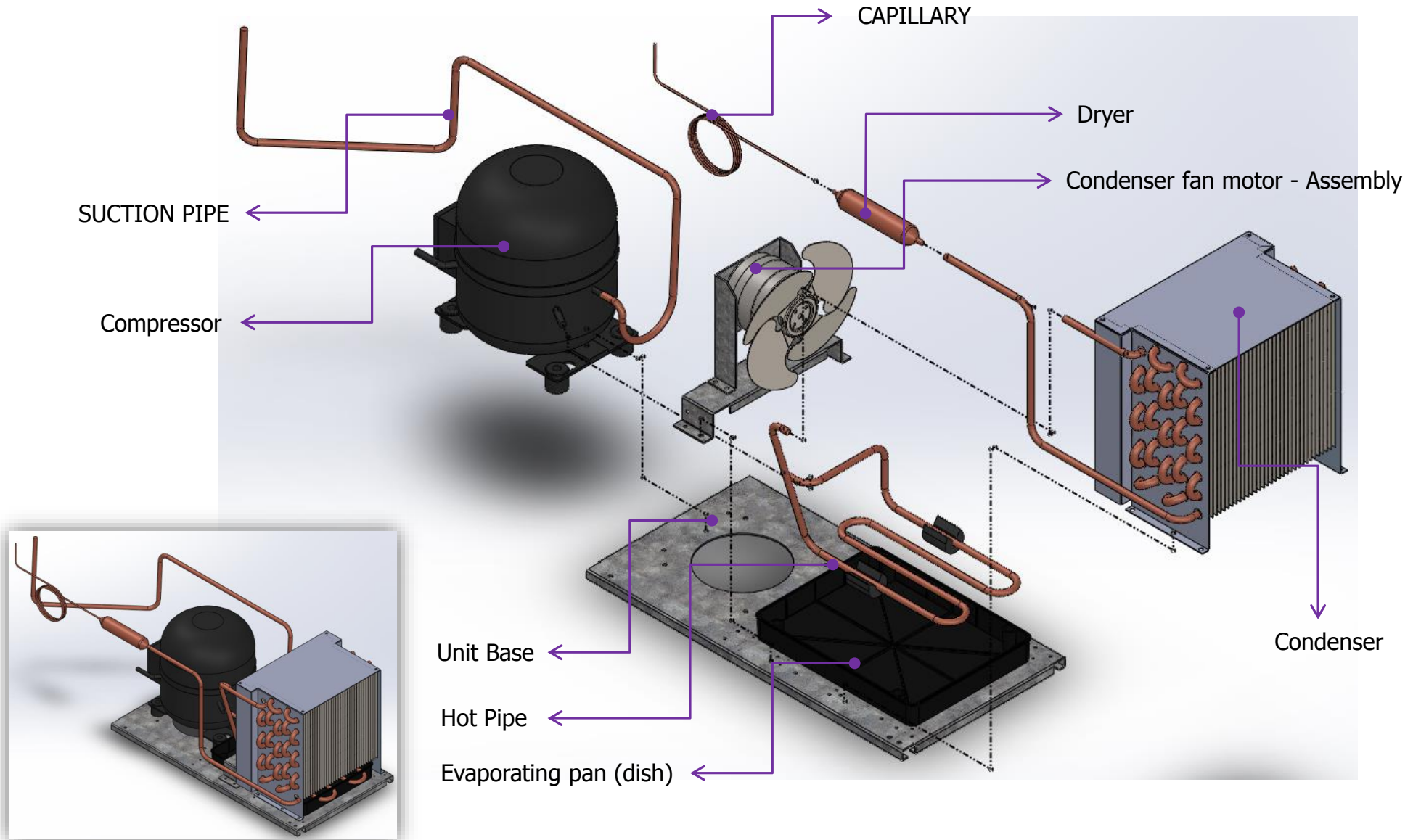

Compressor Wiring - SK1A1C-L2W [USCF-27]

Overload Protector
4TM795TFBZZ-53



PTC Relay -
J531Q34E220M350-3

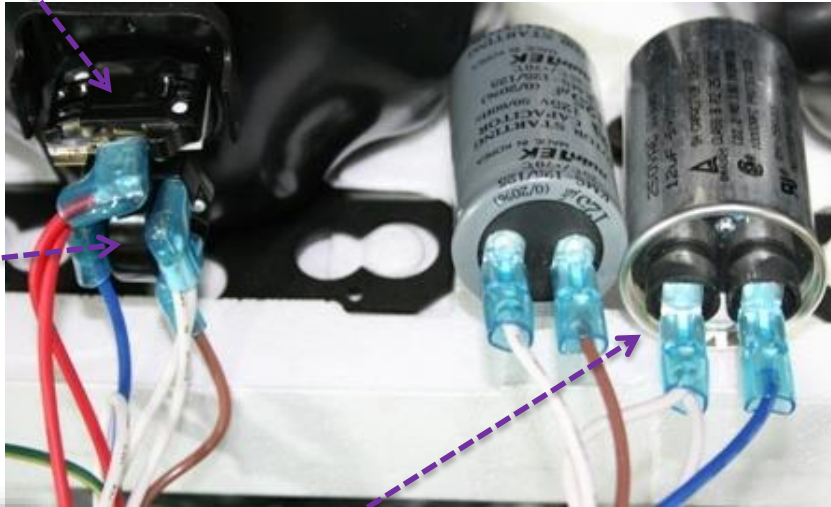

Running Capacitor
250VAC-12 μ F
Starting Capacitor
125VAC-125 μ F

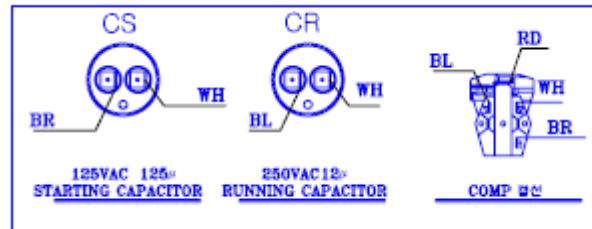

WIRE COLOR
WH : WHITE
BK : BLACK
RD : RED
BR : BROWN
BL : BLUE

■ Compressor Wiring - Scl2clx.2
[USCF-36, USCF-48, USCF-60, USCF-72]



■ Wiring Diagram
[USCF-27]

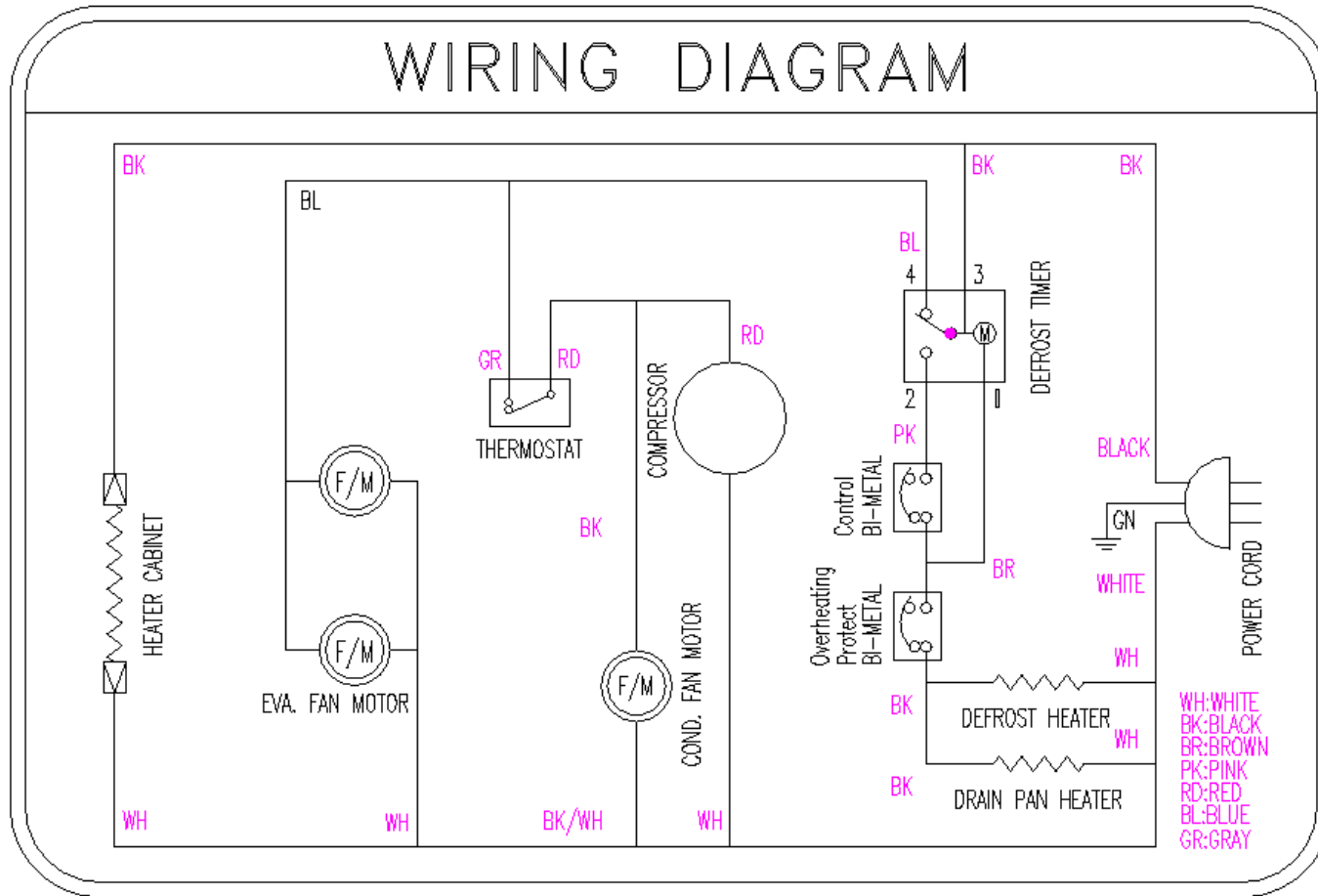

HARNESS COMP
Compressor Type [SD162C-L1U]



HARNESS MAIN



POWER CORD



■ Wiring Diagram

[USCF-36, USCF-48, USCF-60, USCF-72]

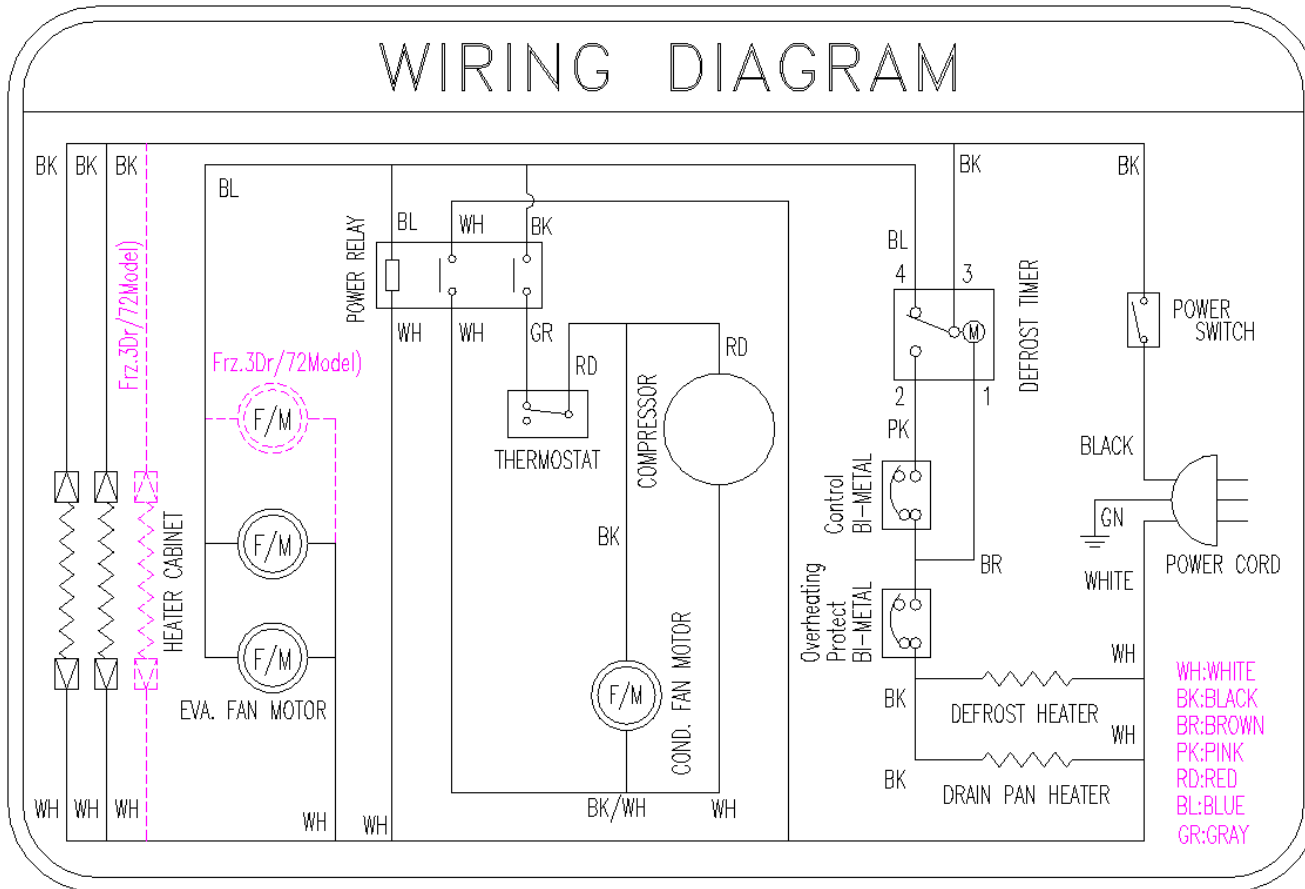

HARNESS COMP
Compressor Type [[SK1A1C-L1U2]



HARNESS MAIN



POWER CORD

