

Sandwich Prep. Table Manual

Model – SUSS-27-8

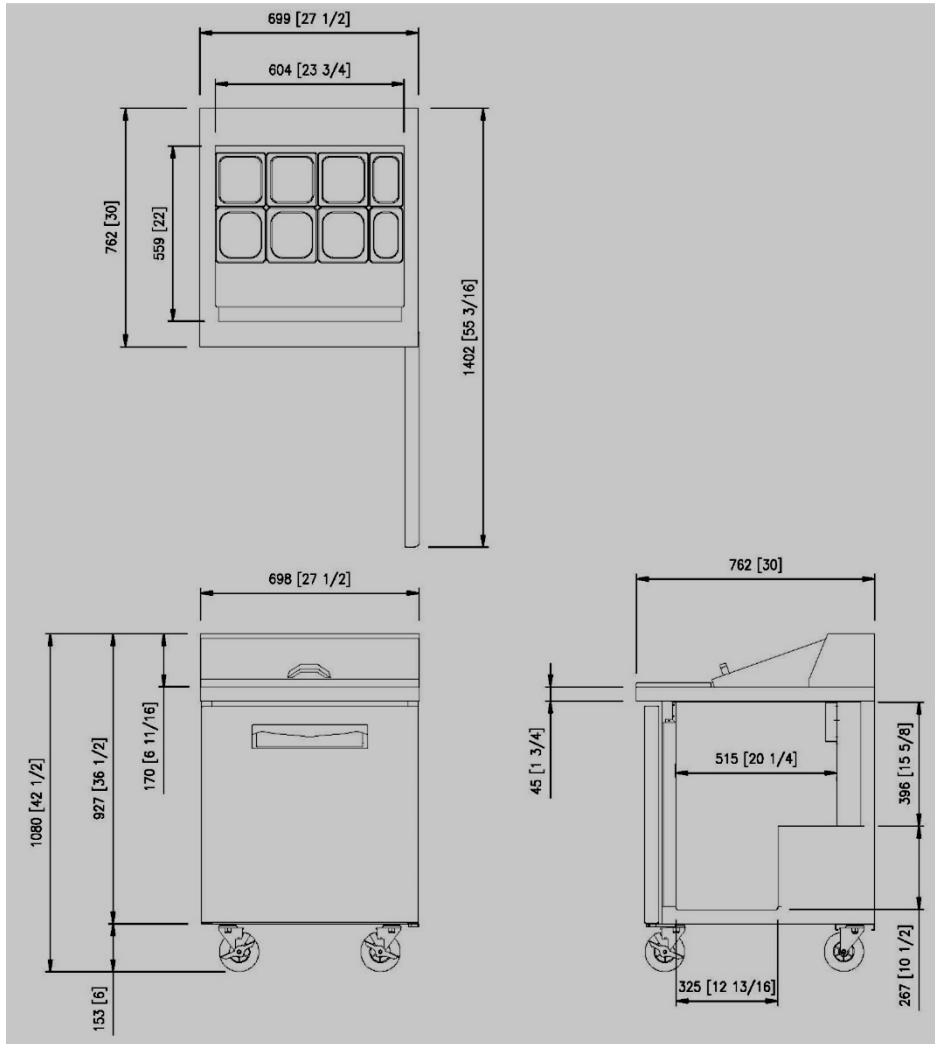

1. Technical Specifications

Amp	115V	3.4A
Connection		15 amp plug
Refrigerant	Name	R134a
	Q'ty (oz)	3.2
	Q'ty (gram)	90
	HP	1/5 HP
Compressor	Samsung	SD162C-L1U2

2. Function Specifications

Temp Range	°F	32°F ~ 40°F
Capacity	Cubic Feet	7
Climate Class		N
Max Ambient Temp	°F	89.6°F
Min Ambient Temp	°F	59°F
Castors	5"	4EA
Shelves		1EA
Doors		1EA
Max No Of Pans	Option	6(1/6"), 2(1/9")
Exterior Finish		Stainless Steel
Interior Finish		Stainless Steel

3. Sizes

Exterior Dimensions	Width(Inches)	27 1/2 inch
	Depth (Inches)	30 inch
	Height (Inches)	42 1/2 inch
Weight	LBS	157 lb

Model – SUSS-36-10

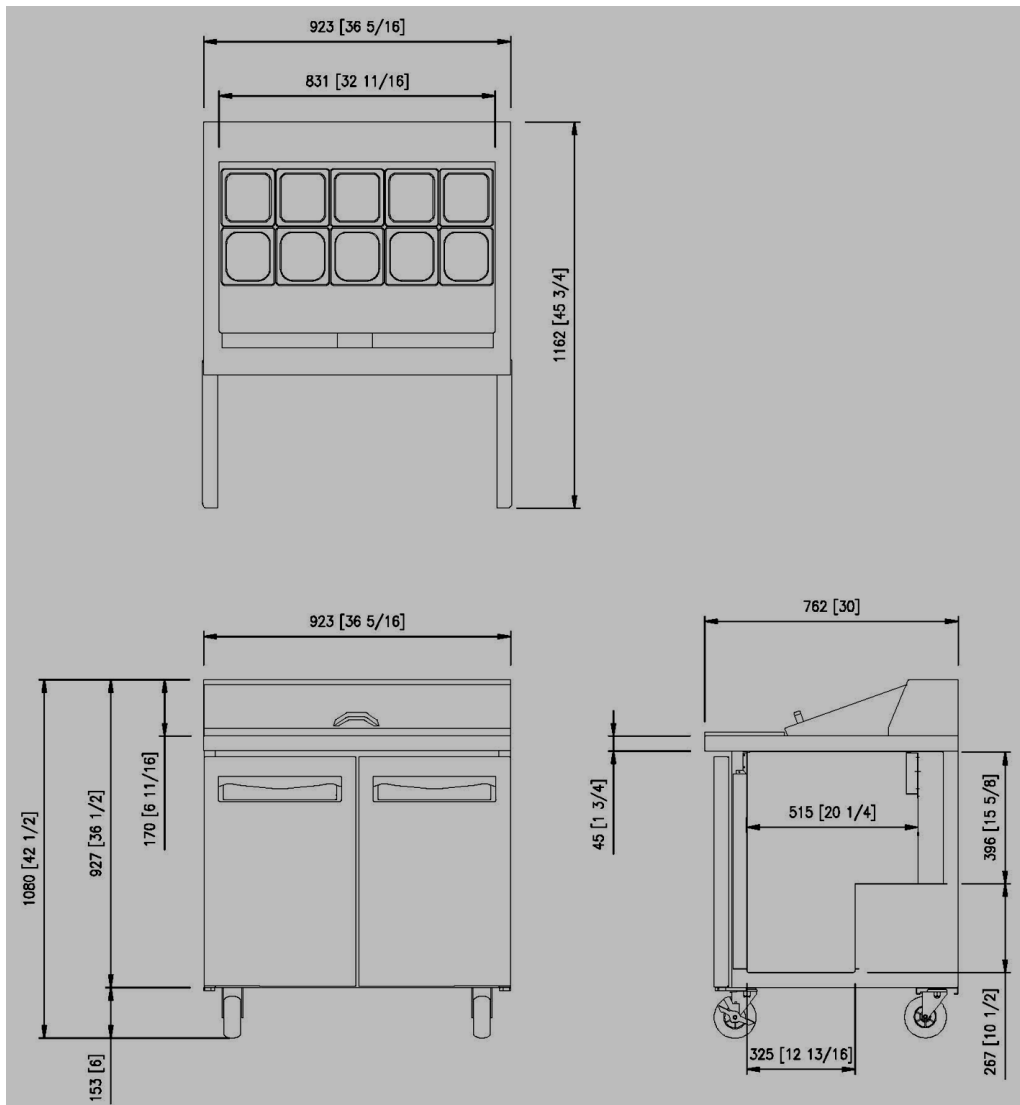

1. Technical Specifications		
Amp	115V	3.4A
Connection		15 amp plug
Refrigerant	Name	R134a
	Q'ty (oz)	3.2
	Q'ty (gram)	90
	HP	1/5 HP
Compressor	Samsung	SD162C-L1U2
2. Function Specifications		
Temp Range	°F	32°F ~ 40°F
Capacity	Cubic Feet	9
Climate Class		N
Max Ambient Temp	°F	89.6°F
Min Ambient Temp	°F	59°F
Castors	5"	4EA
Shelves		2EA
Doors		2EA
Max No Of Pans	Option	10(1/6")
Exterior Finish		Stainless Steel
Interior Finish		Stainless Steel
3. Sizes		
Exterior Dimensions	Width(Inches)	36 5/16inch
	Depth (Inches)	30 inch
	Height (Inches)	42 1/2 inch
Weight	LBS	190 lb

Model – SUSS-48-12

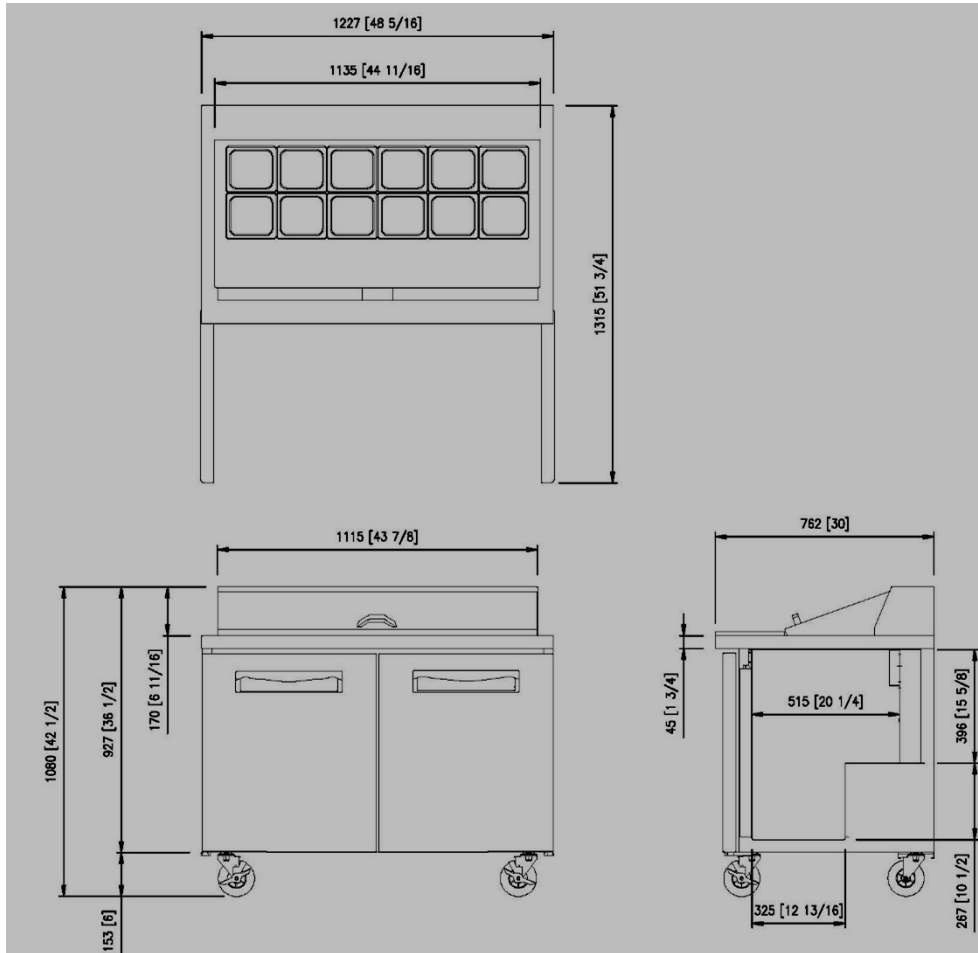

1. Technical Specifications

Amp	115V	6.0A
Connection		15 amp plug
Refrigerant	Name	R134a
	Q'ty (oz)	3.5
	Q'ty (gram)	100
Compressor	HP	3/8 HP
	Samsung	SK1A1C-L2W

2. Function Specifications

Temp Range	°F	32°F ~ 40°F
Capacity	Cubic Feet	12
Climate Class		N
Max Ambient Temp	°F	89.6°F
Min Ambient Temp	°F	59°F
Castors	5"	4EA
Shelves		2EA
Doors		2EA
Max No Of Pans	Option	12(1/6")
Exterior Finish		Stainless Steel
Interior Finish		Stainless Steel

3. Sizes

Exterior Dimensions	Width(Inches)	48 5/16 inch
	Depth (Inches)	30 inch
	Height (Inches)	42 1/2 inch
Weight	LBS	216 lb

Model – SUSS-60-16

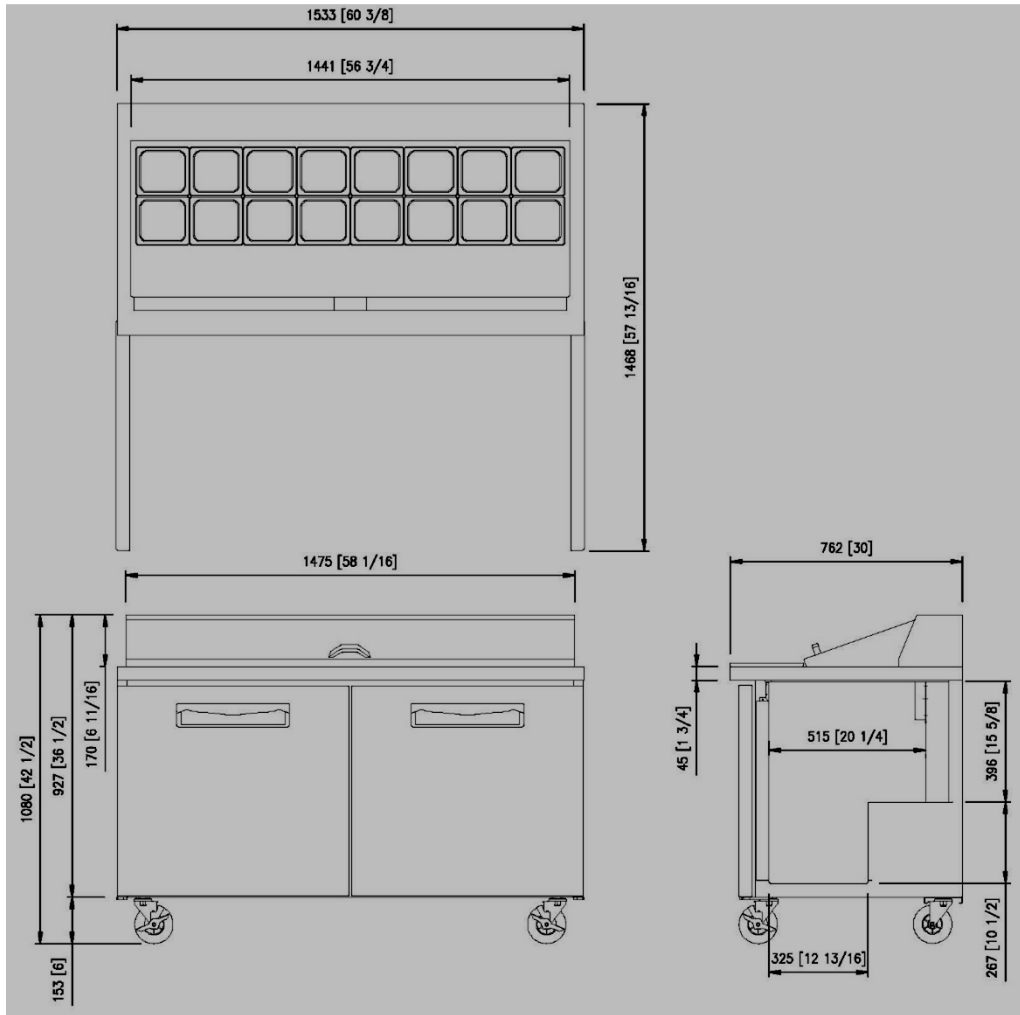

1. Technical Specifications

Amp	115V	6.0A
Connection		15 amp plug
Refrigerant	Name	R134a
	Q'ty (oz)	3.5
	Q'ty (gram)	100
	HP	3/8 HP
Compressor	Samsung	SK1A1C-L2W

2. Function Specifications

Temp Range	°F	32°F ~ 40°F
Capacity	Cubic Feet	16
Climate Class		N
Max Ambient Temp	°F	89.6°F
Min Ambient Temp	°F	59°F
Castors	5"	4EA
Shelves		2EA
Doors		2EA
Max No Of Pans	Option	16(1/6")
Exterior Finish		Stainless Steel
Interior Finish		Stainless Steel

3. Sizes

Exterior Dimensions	Width(Inches)	60 3/8inch
	Depth (Inches)	30 inch
	Height (Inches)	42 1/2 inch
Weight	LBS	260 lb

Model – SUSS-72-18

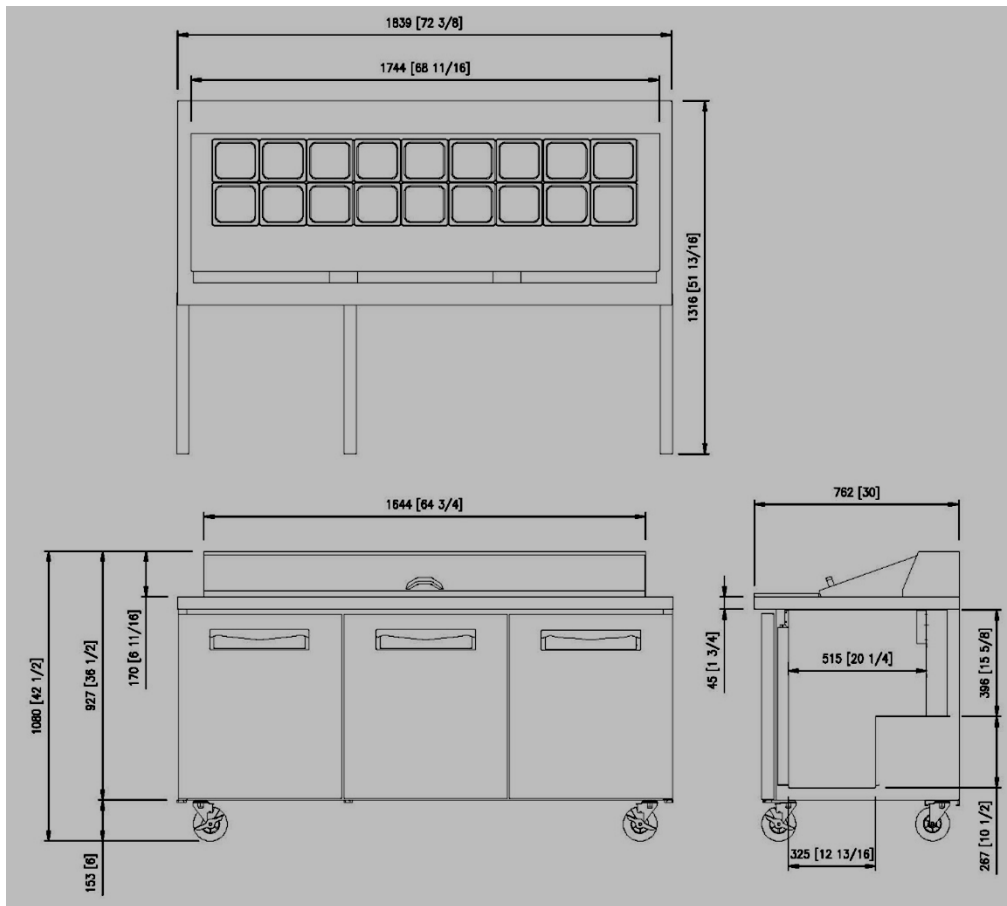

1. Technical Specifications

Amp	115V	6.1A
Connection		15 amp plug
Refrigerant	Name	R134a
	Q'ty (oz)	14.8
	Q'ty (gram)	420
	HP	3/8 HP
Compressor	Samsung	SK1A1C-L2W

2. Function Specifications

Temp Range	°F	32°F ~ 40°F
Capacity	Cubic Feet	20
Climate Class		N
Max Ambient Temp	°F	89.6°F
Min Ambient Temp	°F	59°F
Castors	5"	4EA
Shelves		3EA
Doors		3EA
Max No Of Pans	Option	20(1/6")
Exterior Finish		Stainless Steel
Interior Finish		Stainless Steel

3. Sizes

Exterior Dimensions	Width(Inches)	72 3/8inch
	Depth (Inches)	30 inch
	Height (Inches)	42 1/2 inch
Weight	LBS	298 lb

■ Cabinet - 1

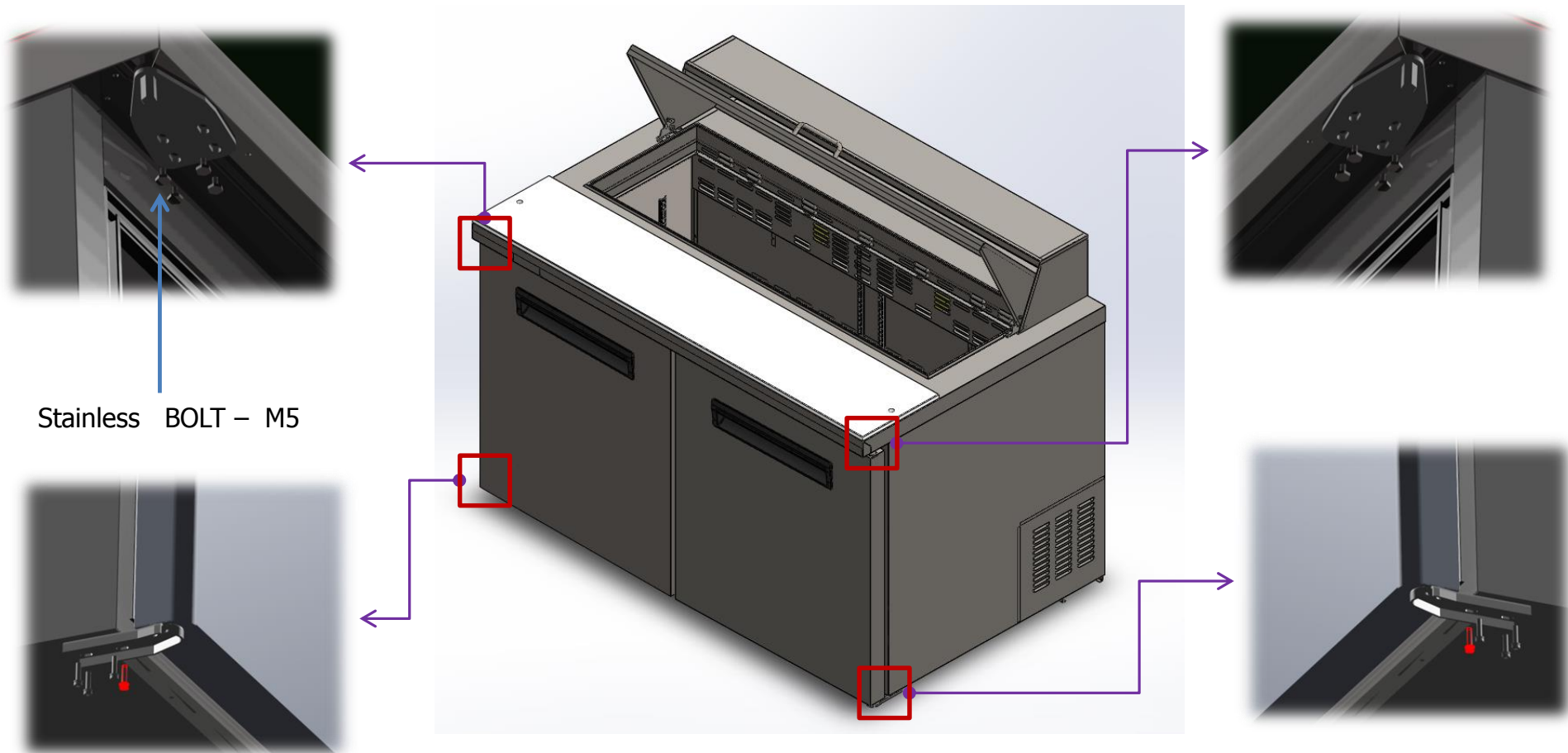

Stainless BOLT - M5

HINGE BOTTOM(LEFT)

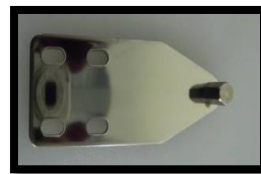

HINGE TOP ASSEMBLY



HINGE BOTTOM(RIGHT)

■ DOOR

HINGE SHAFT

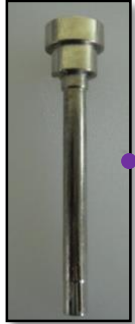

SPRING LEFT

DOOR GASKET

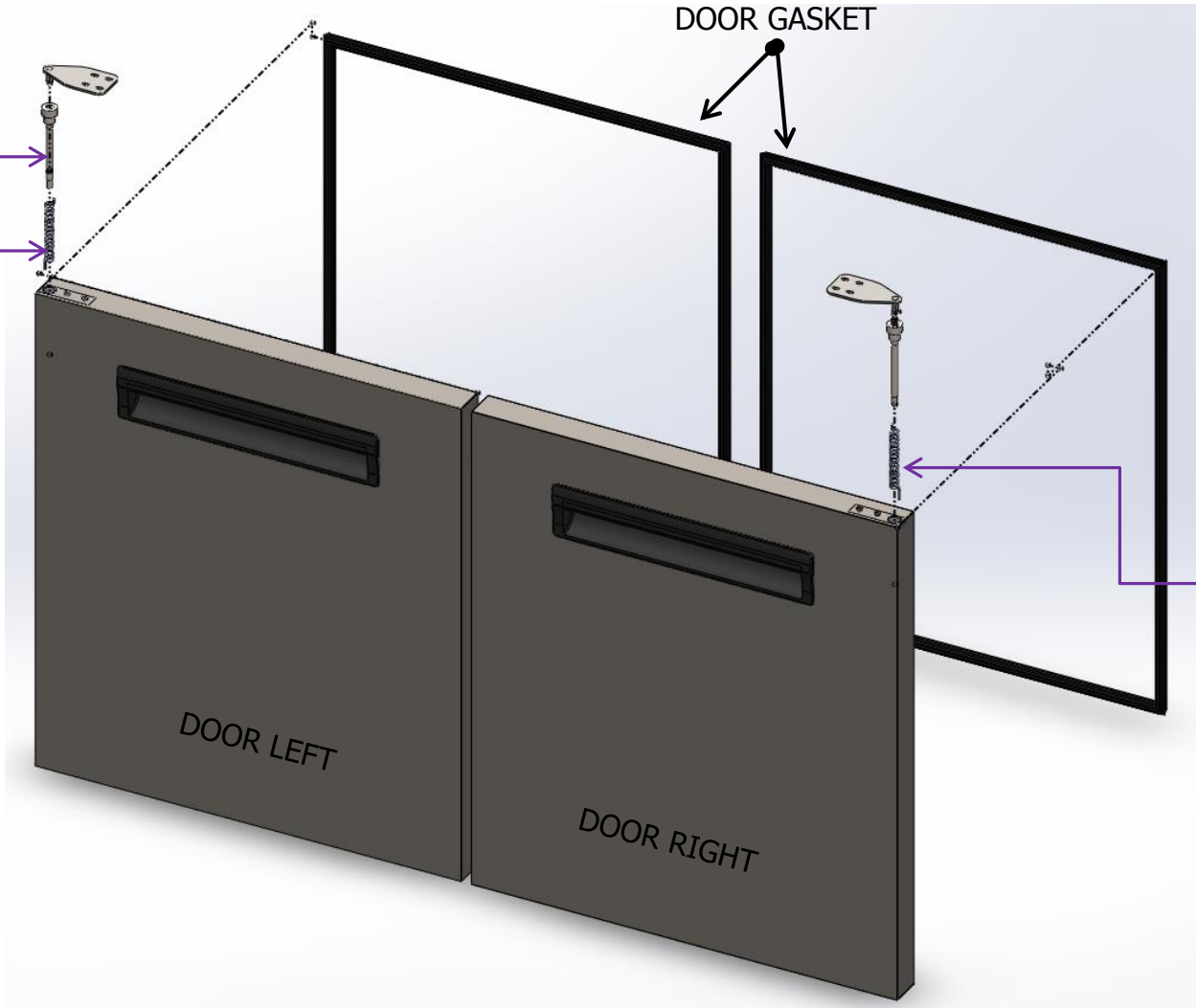

SPRING RIGHT

■ Top

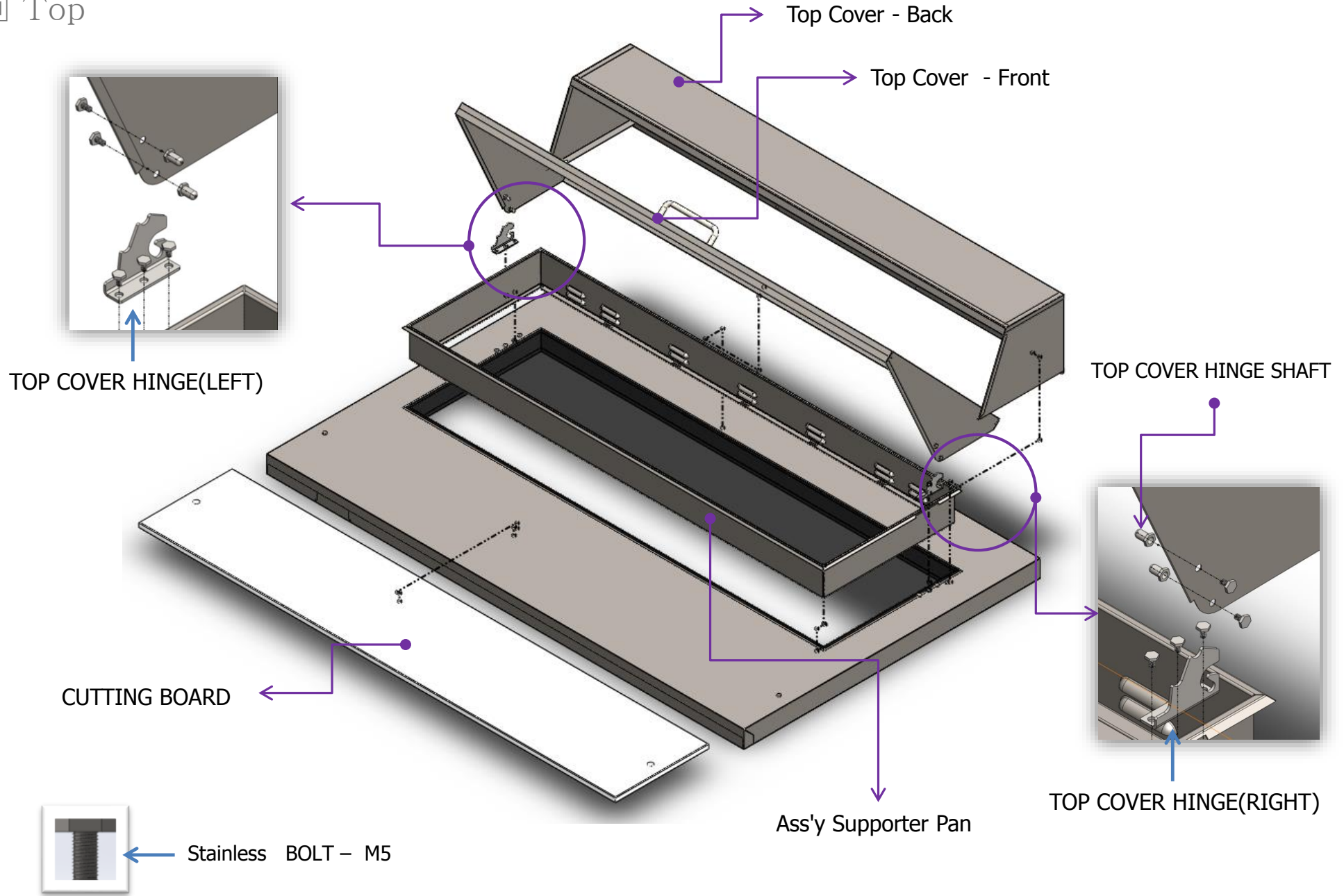

■ Cabinet - 2

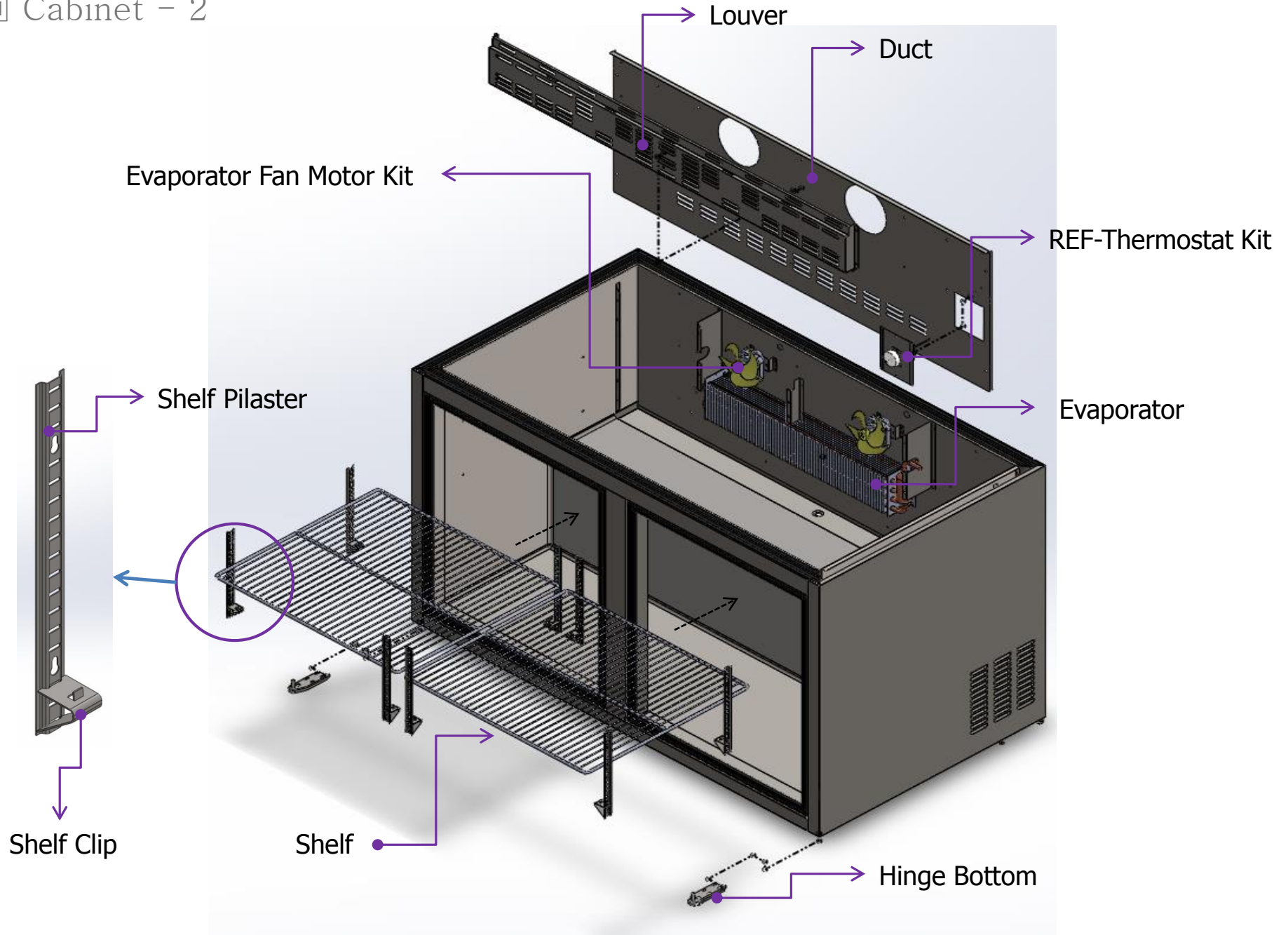

■ Machine room (Refrigeration)-1

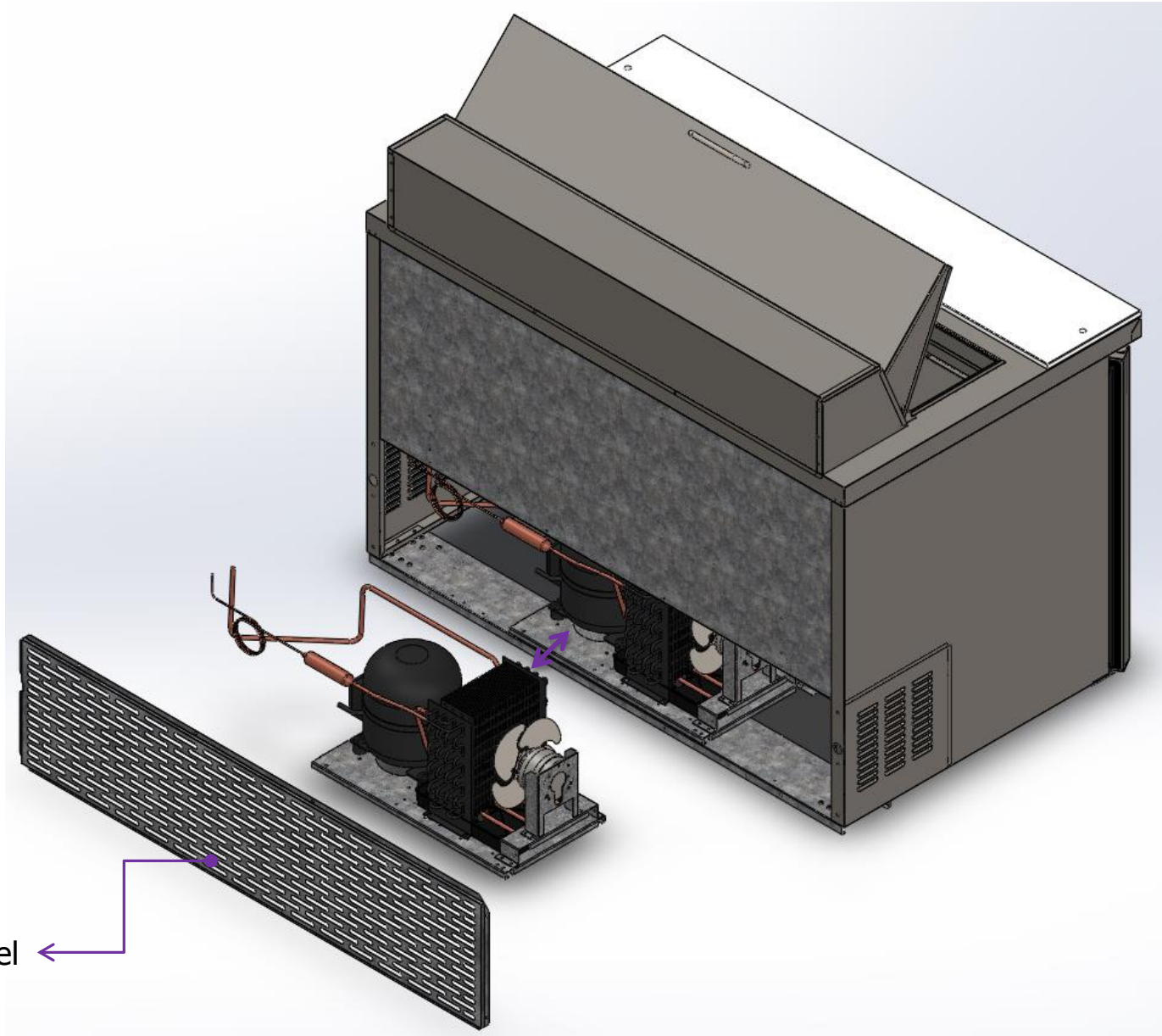

Back Panel

Machine room (Refrigeration)-2

Condensing Unit Disassembly - SUSS-27-8/ 36-10/ 48-12/ 60-16

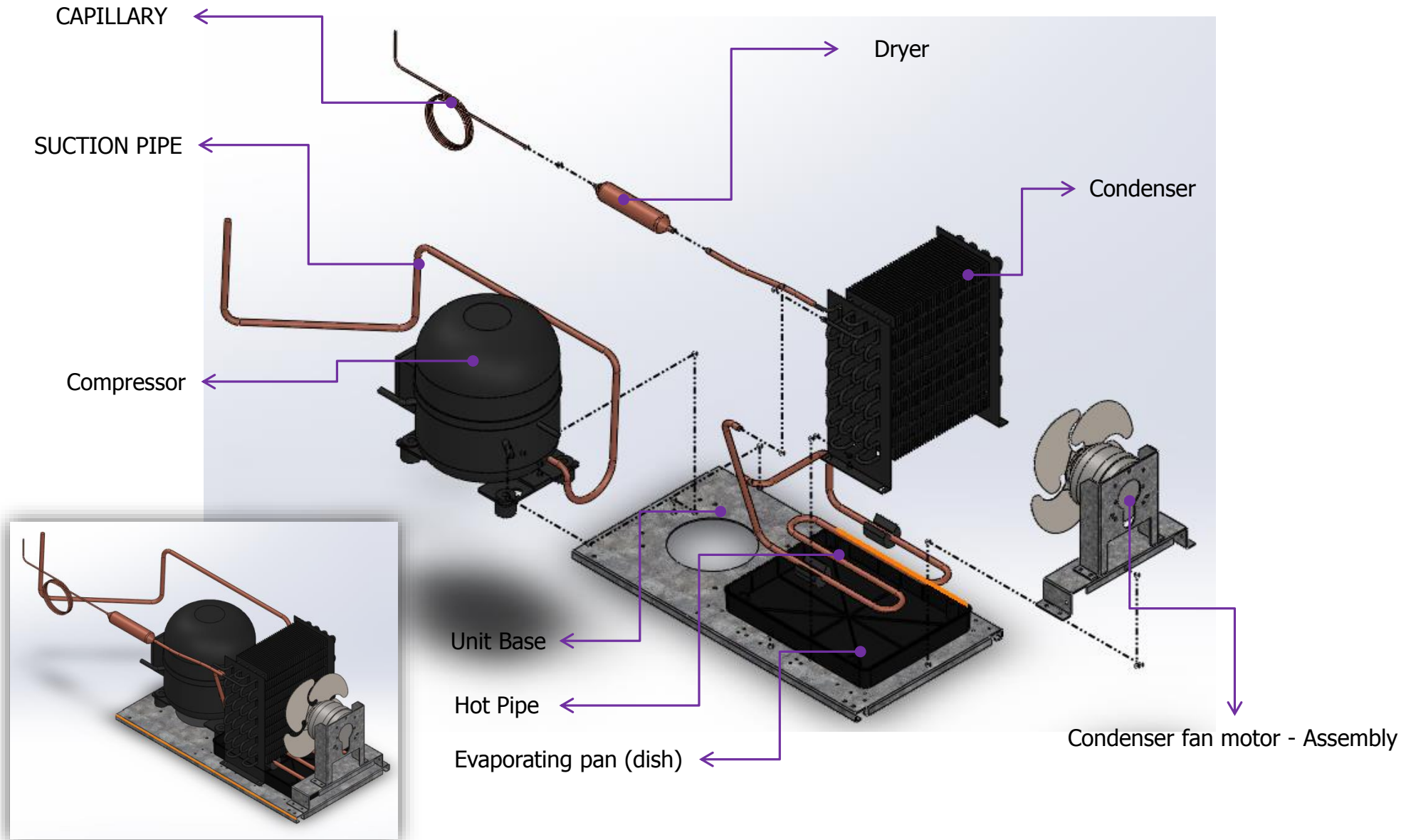

Machine room (Refrigeration)-3
Condensing Unit Disassembly - SUSS-72-18

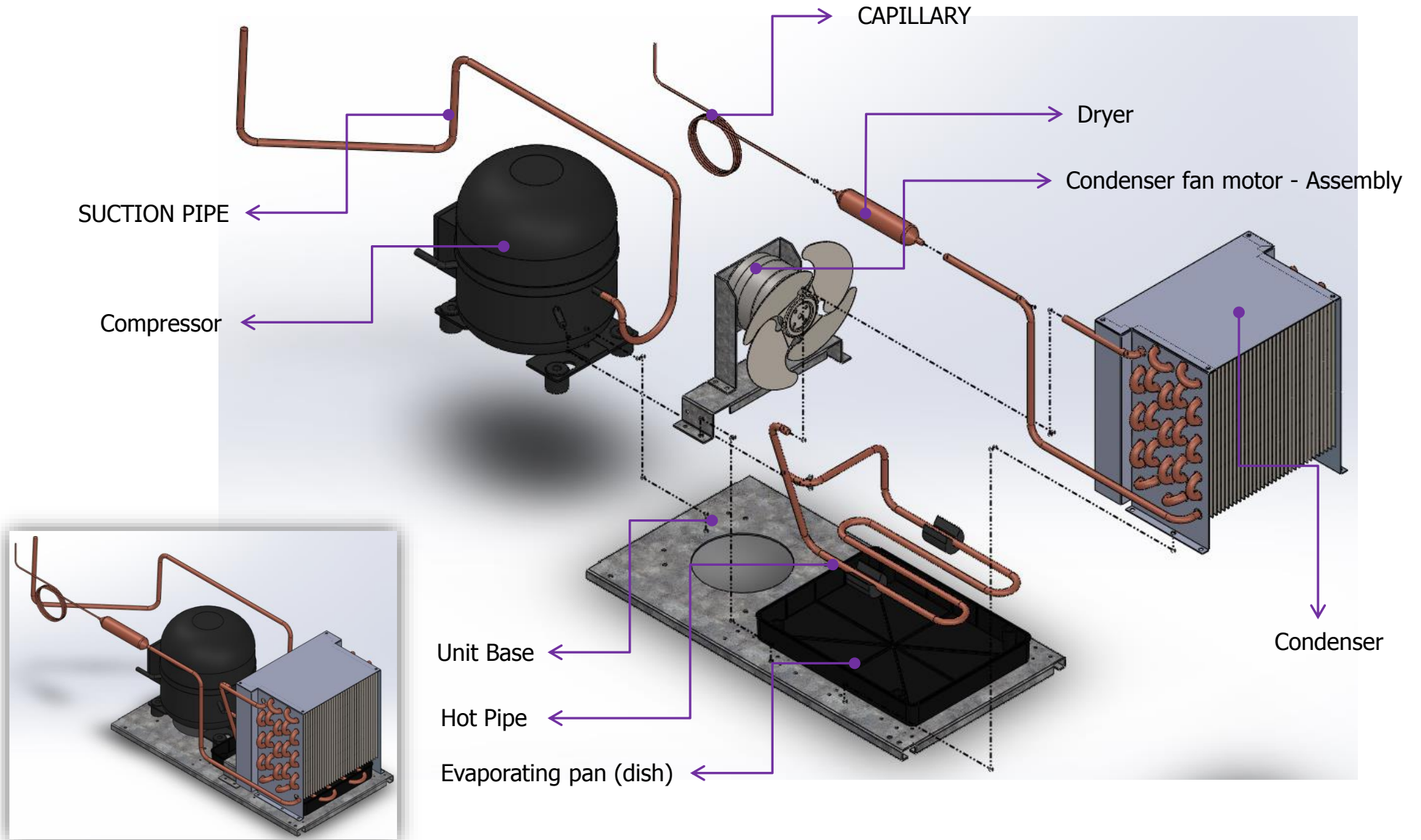

Compressor Wiring - SD162C-L1U [SUSS-27-8, SUSS-36-10]

Overload Protector
4TM427PHBY-53



PTC Relay -
J531Q33E100M200-2



Running Capacitor
250VAC-12 μ F

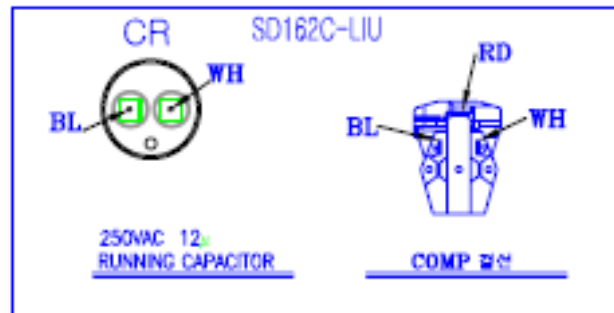
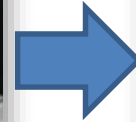

Compressor Wiring - SK1A1C-L2W [SUSS-48-12, SUSS-60-16, SUSS-72-18]

Overload Protector
4TM795TFBZZ-53



PTC Relay -
J531Q34E220M350-3

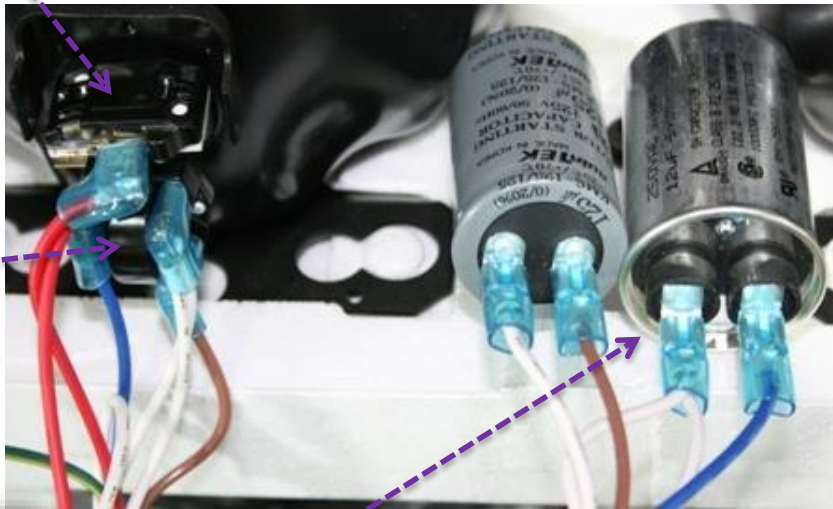

Running Capacitor
250VAC-12µF
Starting Capacitor
125VAC-125µF

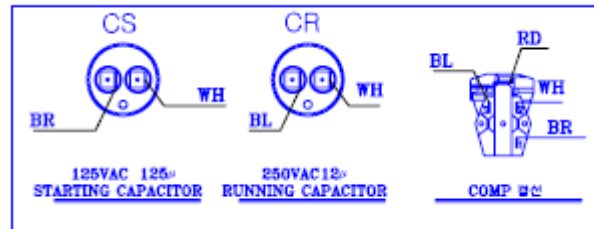

WIRE COLOR
WH : WHITE
BK : BLACK
RD : RED
BR : BROWN
BL : BLUE

■ Wiring Diagram
[SUSS-27-8, SUSS-36-10]

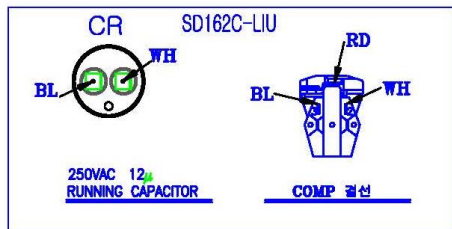
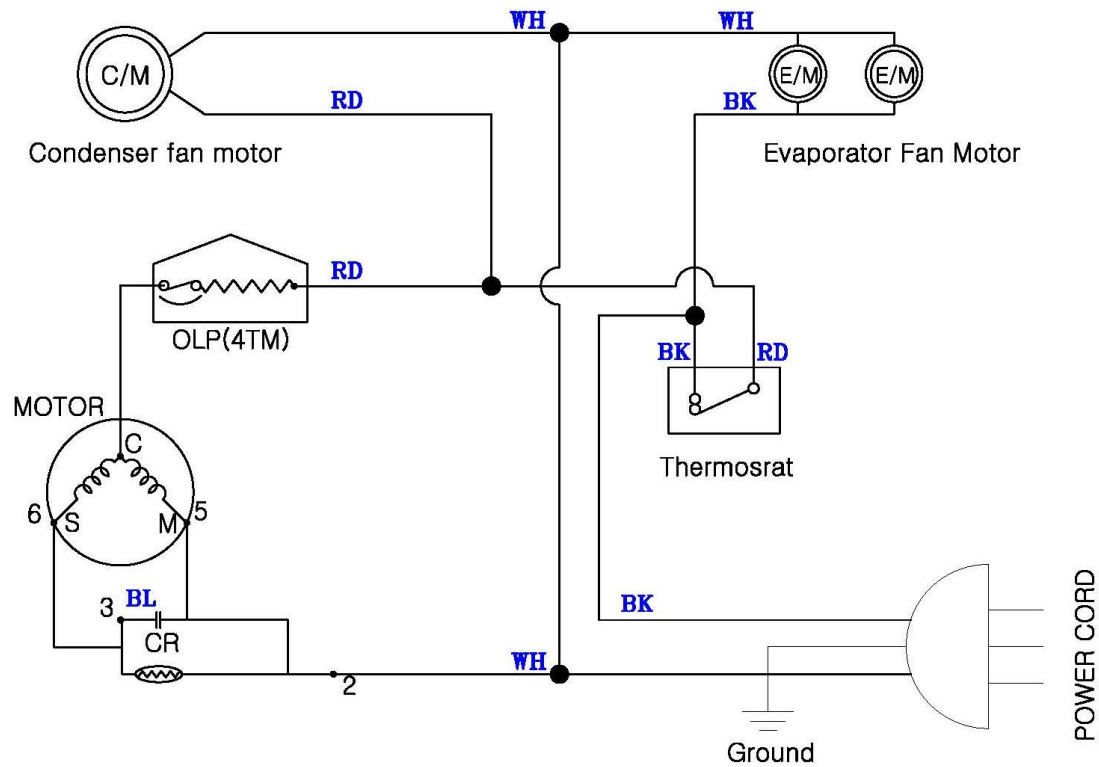

WIRE COLOR
WH : WHITE
BK : BLACK
RD : RED
BR : BROWN
BL : BLUE

HARNESS COMP
Compressor Type [SD162C-L1U]



HARNESS MAIN



POWER CORD



■ Wiring Diagram

[SUSS-48-12, SUSS-60-16, SUSS-72-18]

Ref.3Dr/72Model

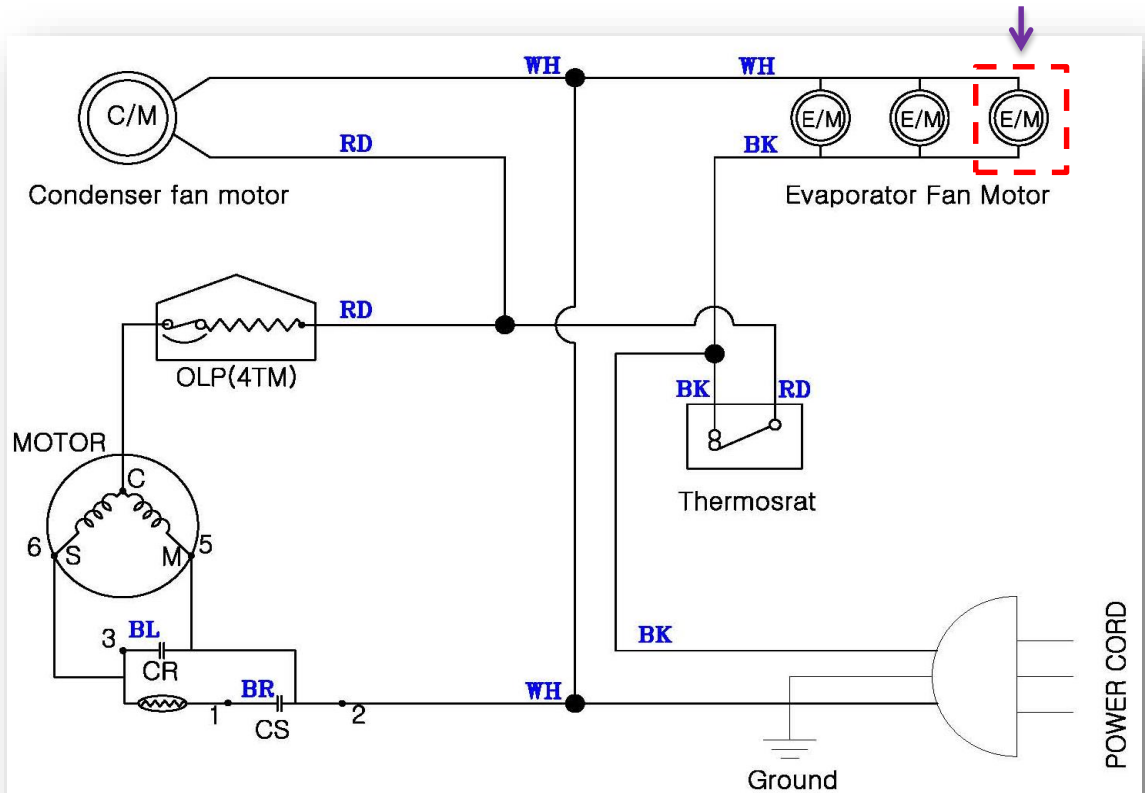

HARNESS COMP
Compressor Type [[SK1A1C-L1U2]



HARNESS MAIN



POWER CORD

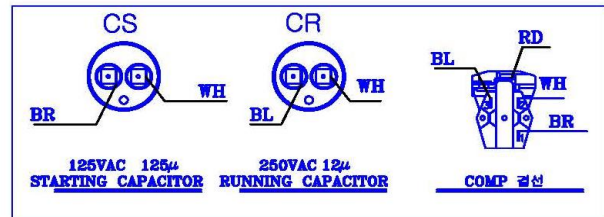
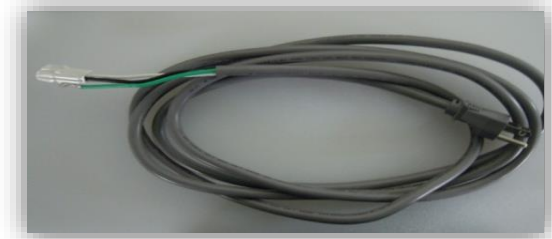

WIRE COLOR
WH : WHITE
BK : BLACK
RD : RED
BR : BROWN
BL : BLUE