

# Salvajor ScrapMaster®

## PARTS BREAKDOWN for Model SM & PSM

For Serial Numbers starting at  
3903 for Model SM and  
at 3690 for Model PSM

### Model SM & PSM System Components

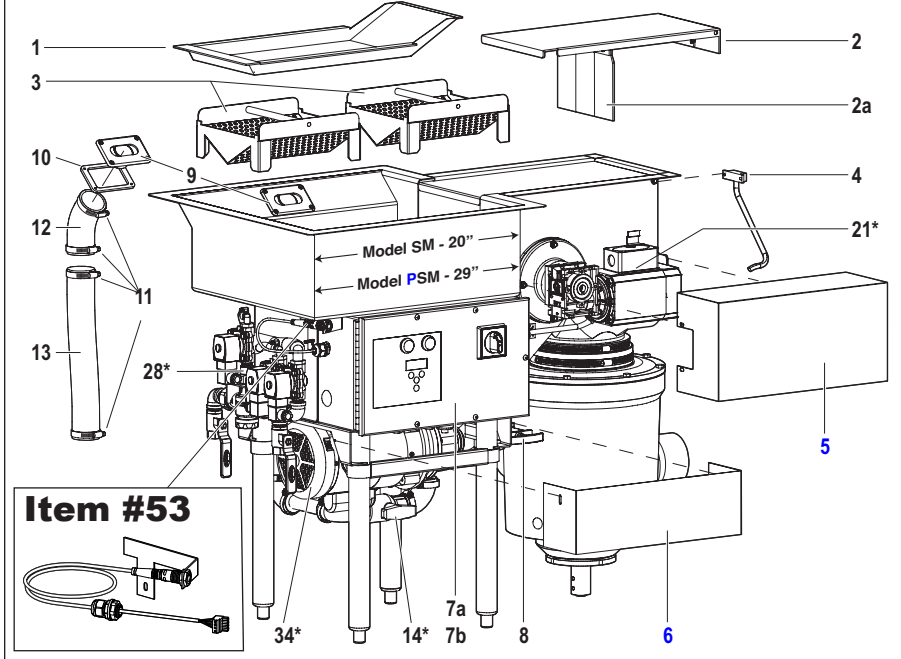

#### Item #53

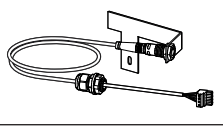

#### Item #14

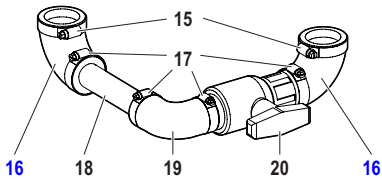

#### Item #28

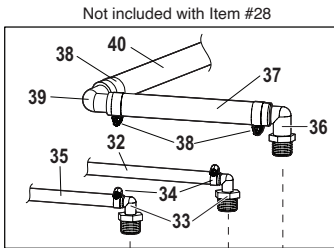

#### Item #21

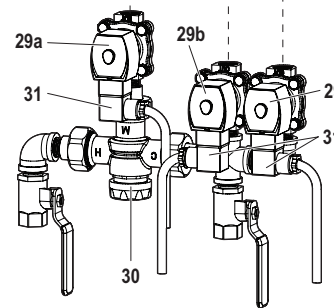
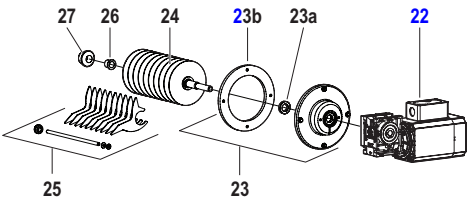

#### Item #41

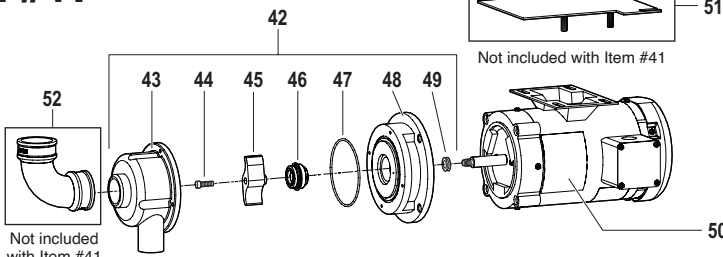

ITEM	PART NO.	DESCRIPTION
1	980145	Salvage Basin
2	980140	Door Assembly w/Proximity Magnet
2a	SM47X5	Rubber Door Gasket (included with 980140)
3	980085	Screen Assembly (2 pc.)
4	980558	Proximity Switch Retrofit Kit
5	980147	Service Cover
6	982230	Pump Cover
7a	007UL	Control Panel 208-230V 3PH
7b	009UL	Control Panel 460V 3PH
8	998058	Slip Valve
9	980146	Gusher Plate
10	996057	Gusher Plate Gasket
11	M32	Clamp S.S.
12	986053	Recirculation Hose 5"
13	986054	Recirculation Hose 13"
14	980559	Pump Plumbing Assy. (includes 15-20)
15	S24	Clamp S.S.
16	S914PDE	Elbow 3/4" x 1" Rubber
17	B16	Clamp S.S.
18	982019	Nipple Pump Valve 6"
19	S914PIE	Elbow Rubber 3/4" x 3/4"
20	75BV	Recirculation Valve
21	980121R	Gearmotor Assy. 208-230/460V 3PH (includes 22-27)
22	981002	Gearmotor 208-230/460V 3PH
23	980060	Separator Cap Assy. (includes 23a-23b)
23a	995007	Seal
23b	SM52G	Gasket
24	980059	Separator Assembly
25	980046	Separator Cleaner Assembly
26	995005	Bearing
27	SM4RBC	Bearing Carrier
28	980191	Water Harness Assembly (includes 29-31)
29a	AS8245DIN	Solenoid Valve Assy 24V (5 GPM Flow Control)
29b	AS8242DIN	Solenoid Valve Assy 24V (2 GPM Flow Control)
29c	AS824DIN	Solenoid Valve Assy 24V (Unrestricted Quick Fill)
30	998124	Tempering Valve
31	994395	DIN Cord Pigtail
32	998022	Water Supply 3/8" Hose - 40.5" (Disposer)
33	998046	Adaptor 3/8" 90 Deg Barb x 1/2" NPT
34	997001	Clamp SS 1/4" to 11/16"
35	998022	Water Supply 3/8" Hose - 37" (Blended)
36	998131	Adaptor 3/4" 90 Deg Barb x 1/2" NPT
37	998130	Water Supply 3/4" Hose - 8.5" (Quick Fill)
38	997183	Clamp SS 1/2" to 1-1/16"
39	998133	Adaptor 3/4" Barb 90 Elbow
40	998130	Water Supply 3/4" Hose - 33" (Quick Fill)
41	980077	Pump and Motor Assy. (includes 41-50)
42	980074	Pump Assembly (includes 41-49)
43	988010	Pump Housing
44	997089	Cap Screw
45	996027	Impeller
46	ECK511	Seal Kit
47	996028	O-Ring
48	988009	Pump Base
49	996030	V-Ring
50	991061	Pump Motor 3-Phase
51	982199	Tank Motor Base Bracket (sold separately)
52	15X90QEL	Elbow 1-1/2" x 90 Rubber (sold separately)
53	980607	Sensor Kit for SM-PSM

U.S. Pat. No. 7,815,134

# SALVAJOR®

# Salvajor ScrapMaster®

## PRE-WIRED CONTROL PANEL PARTS BREAKDOWN

### Model SM & PSM Control Components

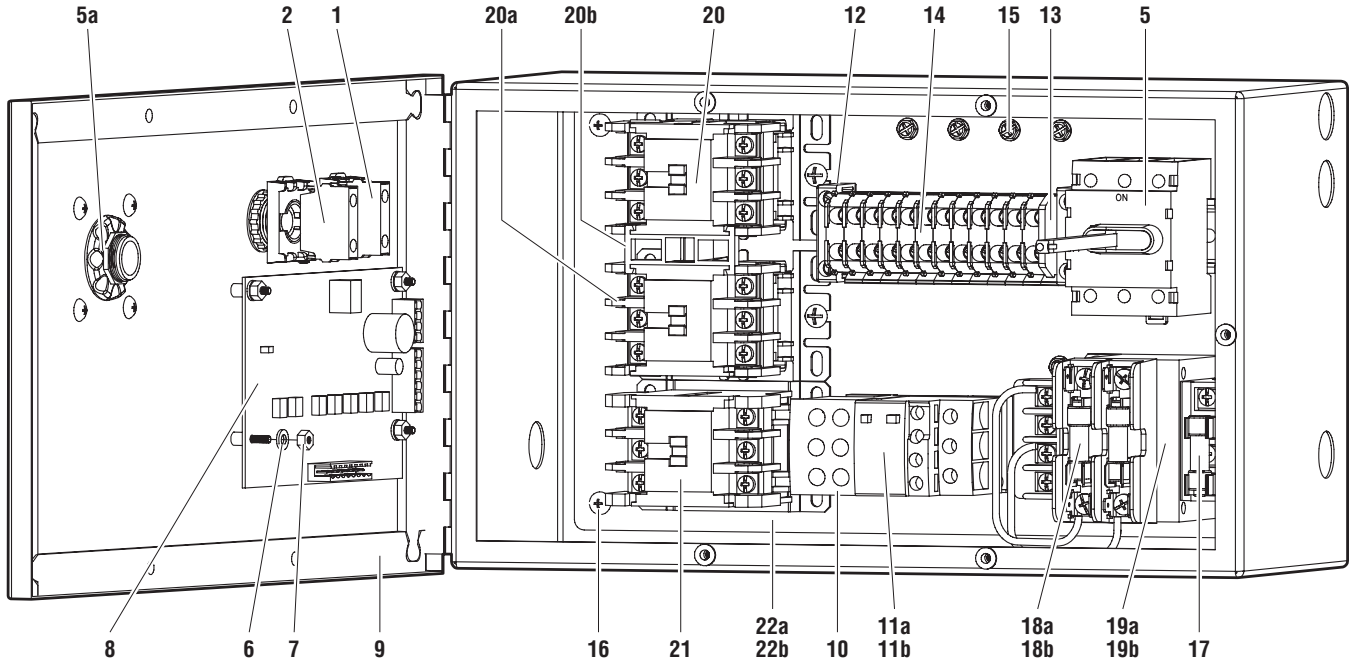

Item Numbers		
VOLTAGE	PHASE	ITEM NO.
208 or 230	3	007UL
460	3	009UL

### Control Box Assembly

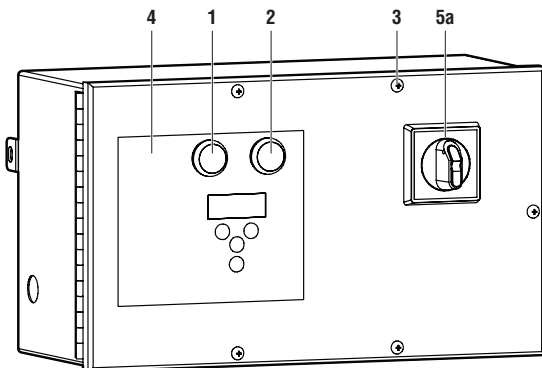

### ITEM PART NO. DESCRIPTION

1	ABD100B	Start Button Assembly
2	ABD200A	Stop Button Assembly
3	997032	Screw 10-32 x 5/8"
4	999258	Control Overlay
5	994177	Line Disconnect Assembly (includes 5a)
5a	984016	Line Disconnect Handle (included with 994177)
6	997161	Flat Washer 6-32
7	997160	Hex Nut 6-32
8	994392	Solid State Control Panel
9	9155GA	Gasket Assembly 9" x 15.5" (4 P.c.)
10	994123	Overload Mounting Base
11a	994291	Overload .8 Amps (for 208-230V 3PH)
11b	994108	Overload .4 Amps (for 460V 3PH)
12	994294	Terminal End Clamp
13	994293	Terminal End Barrier
14	994292	Terminal Block
15	SCR1032	Ground Screw 10-32
16	997093	Screw 10-32 x 3/8"
17	994397	Secondary Fuse 3 Amp
18a	994095	Fuse 1 Amp (for 208-230V 3PH, 2 required)
18b	994112	Fuse 1/2 Amp (for 460V 3PH, 2 required)
19a	994115C	Transformer with 208-230V 3PH (with fuses)
19b	994115D	Transformer with 460V 3PH (with fuses)
20	994380	Contactors 24V Assembly (includes 20a & 20b)
20a	994174	Contactors 24V
20b	994302	Interlock Mechanical
21	994174	Contactors 24V
22a	007ULIP	Inner Panel SS System 208-230V 3PH (incls all electrical components)
22b	009ULIP	Inner Panel SS System 460V 3PH (incls all electrical components)

# SALVAJOR®

4530 East 75th Terrace Kansas City, MO 64132-2081, USA  
 Toll Free: 1.888.725.8256 | Fax: 1.800.832.9373  
 service@salvajor.com | www.salvajor.com