

Commercial Power Direct Vent Water Heater

USE & CARE MANUAL WITH INSTALLATION INSTRUCTIONS FOR THE CONTRACTOR

MULTI-FLUE COMMERCIAL MODELS

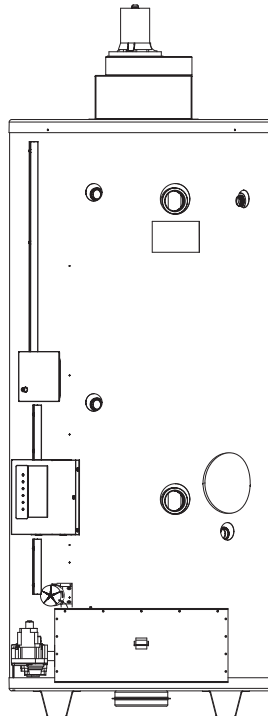

Recognize this symbol as an Indication of Important Safety Information!



Do Not Destroy this Manual. Please read carefully and keep in a safe place for Future Reference.



NOTICE: This water heater is designed for use in a commercial application and the installation and maintenance of it should be performed by a qualified, licensed service personnel. If the foregoing assumption is not appropriate, then we recommend that you obtain and retain our Residential Use & Care Manual.



CALIFORNIA PROPOSITION 65 WARNING: This product contains chemicals known to the State of California to cause cancer, birth defects or other reproductive harm.



WARNING: If the information in these instructions are not followed exactly, a fire or explosion may result causing property damage, personal injury or death.

⚠ FOR YOUR SAFETY!

- Do not store or use gasoline or other flammable vapors or liquids or other combustible materials in the vicinity of this or any other appliance. To do so may result in an explosion or fire.
- WHAT TO DO IF YOU SMELL GAS
 - Do not try to light any appliance.
 - Do not touch any electrical switch; do not use any phone in your building.

- Immediately call your gas supplier from a neighbor's phone. Follow the gas supplier's instructions.
- If you cannot reach your gas supplier, call the fire department.
- Do not return to your building until authorized by the gas supplier or fire department.
- Improper installation, adjustment, alteration, service or maintenance can cause injury, property damage or death. Refer to this manual. Installation and service must be performed by a qualified installer, service agency or the gas supplier.

TABLE OF CONTENTS

Safety Information

Safety Precautions 3-4, 16

Introduction

Local Installation Regulations 5

Water Heater Location 5

Installation Instructions

Inspect Shipment 6

Water Supply Connections 6

Gas Supply 6

Typical Installation 7

Vent Installation 8 - 12

Wiring 13

Installation Checklist 13

Operating Instructions

Lighting Instructions 14-15

Water Temperature 16

Emergency Shut Down 17

Care and Cleaning

Burner Inspection 17

Venting Inspection 17

Routine Maintenance 18

Anode Inspection 18

Seasonal Operation 18

Troubleshooting

System Sentinel Diagnosis 20- 24

Customer Service

Parts List 25

Wiring Diagrams 26-27

How to Obtain Service Assistance 28

READ THE SAFETY INFORMATION

Your safety and the safety of others are very important. There are many important safety messages in this manual and on your appliance. Always read and obey all safety messages.



This is the safety alert symbol. Recognize this symbol as an indication of Important Safety Information! This symbol alerts you to potential hazards that can kill or hurt you and others.

All safety messages will follow the safety alert symbol and either the word “DANGER”, “WARNING”, “CAUTION” or “NOTICE”.

These words mean:

▲ DANGER

An imminently hazardous situation that will result in death or serious injury.

▲ WARNING

A potentially hazardous situation that could result in death or serious injury and/or damage to property.

▲ CAUTION

A potentially hazardous situation that may result in minor or moderate injury.

Notice: Attention is called to observe a specified procedure or maintain a specific condition.

⚠ General Safety Precautions

To meet commercial water use needs, the thermostat on this water heater is adjustable up to 180°F. However, water temperatures over 125°F. can cause severe burns instantly or death from scalds. This is the preferred starting point for setting the control for supplying general purpose hot water.

Safety and energy conservation are factors to be considered when setting the water temperature on the thermostat. The most energy efficient operation will result when the temperature setting is the lowest that satisfies the needs consistent with the application.

The following chart details the relationship of water temperature and time with regard to scald injury and may be used as a guide in determining the safest water temperature for your applications.

Temperature	Time to Produce Serious Burn
120° F	More than 5 minutes
125° F	1½ to 2 minutes
130° F	About 30 seconds
135° F	About 10 seconds
140° F	Less than 5 seconds
145° F	Less than 3 seconds
150° F	About 1½ seconds
155° F	About 1 second

Table courtesy of Shriners Burn Institute

TIME / TEMPERATURE RELATIONSHIPS IN SCALDS

The temperature of the water in the heater can be regulated by setting the temperature dial on front of the thermostat. To comply with safety regulations the thermostat was set at its lowest setting before water heater was shipped from the factory. The illustration below illustrates the thermostat and how to adjust the water temperature.

⚠ DANGER



Water temperature over 125°F can cause severe burns instantly or death from scalds.

Children, disabled and elderly are at highest risk of being scalded.

See instruction manual before setting temperature at water heater.

Feel water before bathing or showering.

Temperature limiting valves are available, see manual.

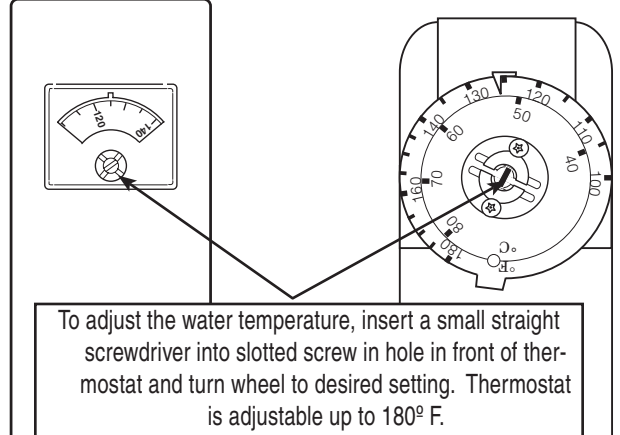

To adjust the water temperature, insert a small straight screwdriver into slotted screw in hole in front of thermostat and turn wheel to desired setting. Thermostat is adjustable up to 180° F.

CAUTION!! - Hotter water increases the risk of SCALDING!



Honeywell



White-Rodgers

NOTICE: Each water heater will contain one (1) of the above thermostats. Refer to actual unit to determine which one.

⚠ DANGER

Hotter water increases the Potential for Hot Water SCALDS.

NOTICE: Mixing valves are available for reducing point of use water temperature by mixing and cold water in branch water lines. Contact a licensed plumber or the local plumbing authority for further information.

Maximum water temperatures occur just after burner has shut off. To find hot water temperature being delivered, turn on a hot water faucet and place a thermometer in the hot water stream and read the thermometer.

⚠ General Safety Precautions

Be sure to read and understand the entire Use & Care Manual before attempting to install or operate this water heater. Pay particular attention to the following General Safety Precautions. Failure to follow these warnings could result in a fire or explosion, causing property damage, bodily injury or death. Should you have any problems understanding the instructions in this manual, STOP, and get help from a qualified installer or service technician or the gas supplier.

⚠ WARNING

Gasoline, as well as other flammable materials and liquids (adhesives, solvents, etc.), and the vapors they produce, are extremely dangerous. DO NOT handle, use or store gasoline or other flammable or combustible materials anywhere near or in the vicinity of a water heater. Be sure to read and follow the warning label pictured below and other labels on the water heater, as well as the warnings printed in this manual. Failure to do so can result in property damage, bodily injury, or death.

⚠ DANGER

Failure to properly vent the water heater to the outdoors as outlined in the Venting Section of this manual can result in unsafe operation of the water heater. To avoid the risk of fire, explosion, or asphyxiation from carbon monoxide, never operate this water heater unless it is properly vented and has an adequate air supply for proper operation. Be sure to inspect the vent system for proper installation at initial start-up; and at least annually thereafter. Refer to Maintenance section of this manual for more information regarding vent system inspections.

⚠ DANGER

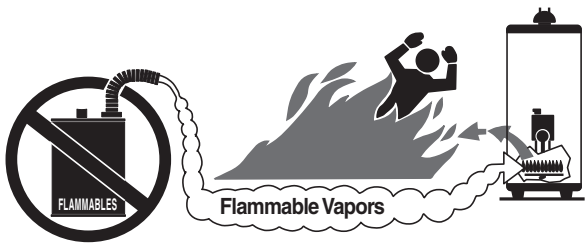

Flammable Vapors

<p>⚠ Vapors from flammable liquids will explode and catch fire causing death or severe burns.</p> <p>Do not use or store flammable products such as gasoline, solvents or adhesives in the same room or area near the water heater.</p> <p>Keep flammable products:</p> <ol style="list-style-type: none">1. far away from heater,2. in approved containers,3. tightly closed and4. out of children's reach.	<p>Water heater has a main burner and pilot flame. The pilot flame:</p> <ol style="list-style-type: none">1. which can come on at any time and2. will ignite flammable vapors. <p>Vapors:</p> <ol style="list-style-type: none">1. cannot be seen,2. are heavier than air,3. go a long way on the floor and4. can be carried from other rooms to the pilot flame by air currents.
---	---

Installation:
Do not install water heater where flammable products will be stored or used unless the main burner and pilot flames are at least 18" above the floor. This will reduce, but not eliminate, the risk of vapors being ignited by the main burner or pilot flame.

Read and follow water heater warnings and instructions. If owners manual is missing, contact the retailer or manufacturer.

⚠ DANGER

LIQUEFIED PETROLEUM MODELS – Propane, or LP gas, must be used with great caution.

- It is heavier than air and will collect first in lower areas making it hard to detect at nose level.
- Make sure to look and smell for LP leaks before attempting to light appliance. Use a soapy solution to check all gas fittings and connections. Bubbling at a connection indicates a leak that must be corrected. When smelling to detect an LP leak, be sure to sniff near the floor too.
- Gas detectors are recommended in LP applications and their installation should be in accordance with the manufacturer's recommendations and/or local laws, rules, regulations or customs.
- It is recommended that more than one method be used to detect leaks in LP applications.

IF LP GAS IS PRESENT OR SUSPECTED:

- DO NOT attempt to find the cause yourself;
- DO NOT try to light any appliance;
- DO NOT touch any electrical switch;
- DO NOT use any phone in your building.
- Leave the house immediately and make sure your family and pets leave also.
- Leave the doors open for ventilation and contact the gas supplier, a qualified service agency or the fire department.
- Keep the area clear until the service call has been made, the leak is corrected, and a qualified agency has determined the area to be safe.

⚠ WARNING

Both LP and natural gas have an odorant added to help detection. Some people may not physically be able to smell or recognize this odorant. If unsure or unfamiliar about the smell associated with LP or natural gas, ask the gas supplier. Other conditions, such as "Odorant Fade", which causes the odorant to "fade", or diminish in intensity can also hide or camouflage a gas leak.

⚠ DANGER

Water heaters utilizing Liquefied Petroleum gas (LP) are different from natural gas models. A natural gas heater will not function safely on LP gas and vice versa. No attempt should ever be made to convert a heater from natural gas to LP gas. To avoid possible equipment damage, personal injury or fire: DO NOT connect this water heater to a fuel type not in accordance with unit data plate. Propane for propane units. Natural gas for natural gas units. These units are not certified for any other type fuel.

⚠ WARNING

LP appliances should not be installed below-grade (for example, in a basement) if such installation is prohibited by federal, state and/or local laws, rules, regulations or customs.

Introduction

WARNING

Read and Review this entire Manual with special emphasis on the Venting Sections (Pages 8-12) and Operation Section (Pages 14-17) prior to any installation work.

LOCAL INSTALLATION REGULATIONS

This water heater must be installed in accordance with these instructions, local codes, utility company requirements and/or, in the absence of local codes, the latest edition of the National Fuel Gas Code, ANSI Z223.1 in the United States, or CGA/CAN B149 Installation Codes in Canada.

LOCATION

A. This water heater is of the direct vent design. All air for combustion and all products of combustion are routed through the venting system, directly from and to the outside of the building.

The water heater should be installed in a clean, dry location as close as practical to the gas vent terminals. Long hot water lines should be insulated to conserve water and energy. The water heater and water lines should be protected from exposure to freezing temperatures.

B. A gas fired water heater should not be installed in a space where liquids which give off flammable vapors are to be used or stored. Such liquids include gasoline, LP gas (butane and propane), paint or adhesives and their thinners, solvents or removers. Because of natural air movement in a room or other enclosed space, flammable vapors can be carried some distance from where their liquids are being used or stored. The open flame of the water heater's intermittent pilot or main burner can ignite these vapors causing an explosion or fire which may result in severe burns or death to those in range, as well as property damage. For these reasons, installation of a gas fired water heater in a garage is not desirable.

WARNING

If a location in a garage is the only alternative, the gas water heater should be installed so that the open flame of the pilot and main burner are no less than 18 inches above the garage floor. The water heater must be located or protected so it is not subject to physical damage by moving vehicles or area flooding. Raising the gas fired water heater will reduce BUT NOT eliminate the possibility of lighting the vapor of any flammable liquids which may be improperly stored or accidentally spilled.

C. All models are certified for installation on combustible floors and in alcoves. The minimum side and top clearance to walls and ceiling for providing protection of combustible materials are shown on the water heater's rating label. A front clearance of 18 inches (46 cm) should be provided for adequate inspection and servicing.

If the water heater must be installed on carpeting, place a metal or wood panel beneath water heater extending beyond its full width and depth at least 3 inches (7.6 cm) in all directions. If the water heater is installed in an alcove, the entire floor must be covered by the panel.

The water heater should not be located in an area where leakage of the tank or connections will result in damage to the area adjacent

CAUTION

to it or to lower floors of the structure. When such areas cannot be avoided, it is recommended that a suitable catch pan, adequately drained, be installed under the water heater. The pan MUST NOT restrict the flow of combustion air flow to bottom of water heater.

NOTICE: Auxiliary catch pan installation MUST conform to the applicable local codes.

D. RESTAURANTS — If the water heater is to be installed in a restaurant or other location where the floor is frequently cleaned, it must be elevated to provide at least six inches (15 cm) of clearance from the floor to comply with NSF International recommendations.

E. CORROSIVE ATMOSPHERES — The heater should not be installed near an air supply containing halogenated hydrocarbons. For example, the air in beauty shops, dry cleaning establishments, photo processing labs, and storage areas for liquid and powdered bleaches or swim pool chemicals often contain such hydrocarbons. The air there may be safe to breathe, but when it passes through a gas flame, corrosive elements are released that will shorten the life of any gas burning appliance. Propellants from common spray cans or gas leaks from refrigeration equipment are highly corrosive after passing through a flame. The limited warranty is voided when failure of water heater is due to a corrosive atmosphere. (Refer to the Certificate of Limited Warranty for complete terms and conditions.)

Installation

WARNING

The manufacturer's warranty does not cover any damage or defect caused by installation, or attachment, or use of any special attachment such as energy saving devices (other than those authorized by the manufacturer) into, onto, or in conjunction with the water heater. The use of such unauthorized devices may shorten the life of the water heater and may endanger life and property. The manufacturer disclaims any responsibility for such loss or injury resulting from the use of such unauthorized devices.

1. INSPECT SHIPMENT — for possible damage. The manufacturer's responsibility ceases upon delivery of goods to the carrier in good condition. Any claims for damage, shortage in shipments, or non-delivery must be filed immediately against carrier by consignee.
2. THERMAL EXPANSION — Determine if a check valve exists in the inlet water line. It may have been installed in the cold water line as a separate back flow preventer, or it may be part of a pressure reducing valve, water meter or water softener. A check valve located in the cold water inlet line can cause what is referred to as a "closed water system". A cold water inlet line with no check valve or back flow prevention device is referred to as an "open" water system.

As water is heated, it expands in volume and creates an increase in the pressure within the water system. This action is referred to as "thermal expansion". In an "open" water system, expanding water which exceeds the capacity of the water heater flows back into the city main where the pressure is easily dissipated.

A "closed water system", however, prevents the expanding water from flowing back into the main supply line, and the result of "thermal expansion" can create a rapid, and dangerous pressure increase in the water heater and system piping. This rapid pressure increase can quickly reach the safety setting of the relief valve, causing it to operate during each heating cycle. Thermal expansion, and the resulting rapid, and repeated expansion and contraction of components in the water heater and piping system can cause premature failure of the relief valve, and possibly the heater itself. Replacing the relief valve will not correct the problem!

The suggested method of controlling thermal expansion is to install an expansion tank in the cold water line between the water heater and the check valve. The expansion tank is designed with an air cushion built in that compresses as the system pressure increases, thereby relieving the over pressure condition and eliminating the repeated operation of the relief valve. Other methods of controlling thermal expansion are also available. Contact your installing contractor, water supplier, or plumbing inspector for additional information regarding this subject.

If a recirculation line is installed, the return connection should be made to a tee close to the inlet connection on the water heater. A check valve should always be installed in the recirculation line to prevent cold water from entering.

WATER CONNECTIONS — This water heater may be connected individually, in multiples with others, or with an external hot water storage tank.

Inlet water connections are made to the lower coupling on the heater, and outlet water connections are made to the upper coupling.

Each water heater is supplied with the necessary components (Diffuser tubes) to make the water connections that will ensure proper performance. The components are supplied in a bag attached to the water

heater. If special instructions are required for any specific water heater, they will be included in the bag.

Cap or plug unused connections. Use only clean, new galvanized steel, copper or approved plastic pipe for water connections. Local codes or regulations shall govern the exact type of material to be used. The installation of unions on the inlet and outlet water lines and a shut-off valve in at least the cold water inlet line is recommended, so the water heater may be easily disconnected for servicing. Dielectric unions are not required for protection of water heater.

When this water heater is supplying general purpose hot water requirements for use by individuals, a thermostatically controlled mixing valve is recommended to reduce the risk of scald injury. Contact a licensed plumber or the local plumbing authority for further information.

Thermometer(s) should be installed so that they indicate the temperature of the water at or near the outlet of the water heater and storage tank(s) if provided. See Fig. 4 on page 7.

3. RELIEF VALVE — A new factory installed combination pressure and temperature relief valve, complying with the Standard for Relief Valves and Automatic Gas Shutoff Devices for Hot Water Supply Systems, ANSI Z21.22, or Standard CAN1-4.4, Temperature, Pressure, Temperature and Pressure Relief Valves and Vacuum Relief Valves is provided with the water heater. No valve is to be placed between the relief valve and the water heater. For a circulating tank installation, the separate storage tank(s) must have similar protection. The pressure rating of the relief valve must not exceed 150 psi (160 psi for ASME models), the maximum working pressure as marked on front of the water heater.

The Btu/h rating of the relief valve must equal or exceed the Btu/h input of the water heater as marked on its rating plate.

Connect the outlet of the relief valve to a suitable open drain. The discharge line must pitch downward from the valve to allow complete draining (by gravity) of the relief valve and discharge line, and be no smaller than the outlet of the valve. The end of the discharge line should not be threaded or concealed and should be protected from freezing. No valve of any type, restriction or reducer coupling should be installed in the discharge line. Local codes shall govern the installation of relief valves.

4. GAS SUPPLY — The inlet gas pressure to the water heater must not exceed 10.5" w.c. (2.6 kPa) for Natural gas. For purposes of input adjustment, the minimum inlet gas pressure (with main burner on) is shown on the rating plate. Check to see if high or low gas pressure is present and then contact the gas company for correction.

The gas line should be of adequate size to prevent undue pressure drop. Sizing based upon Table 1 (on pg. 13) is recommended. No additional allowance is necessary for an ordinary number of fittings.

A ground joint union and manual shutoff valve should be installed in the gas line near the water heater so that the burner assembly may be easily removed. The shut-off valve must be readily accessible for turning on or off. See Fig. 4 on page 7.

A sediment trap must be installed at the bottom of the gas line. See Fig. 4 on page 7.

LEAK TESTING — The water heater and its gas connections MUST be leak tested at normal operating pressure before it is placed in operation. Turn ON the manual gas shut-off valve near the water heater. Use a soapy water solution to test for gas leaks at all connections and fittings. Bubbles indicate a gas leak that must be corrected. The water heater factory connections to the gas valve should also be leak tested after placing the water heater in operation.

Figure 4. — Typical Installation Drawing.

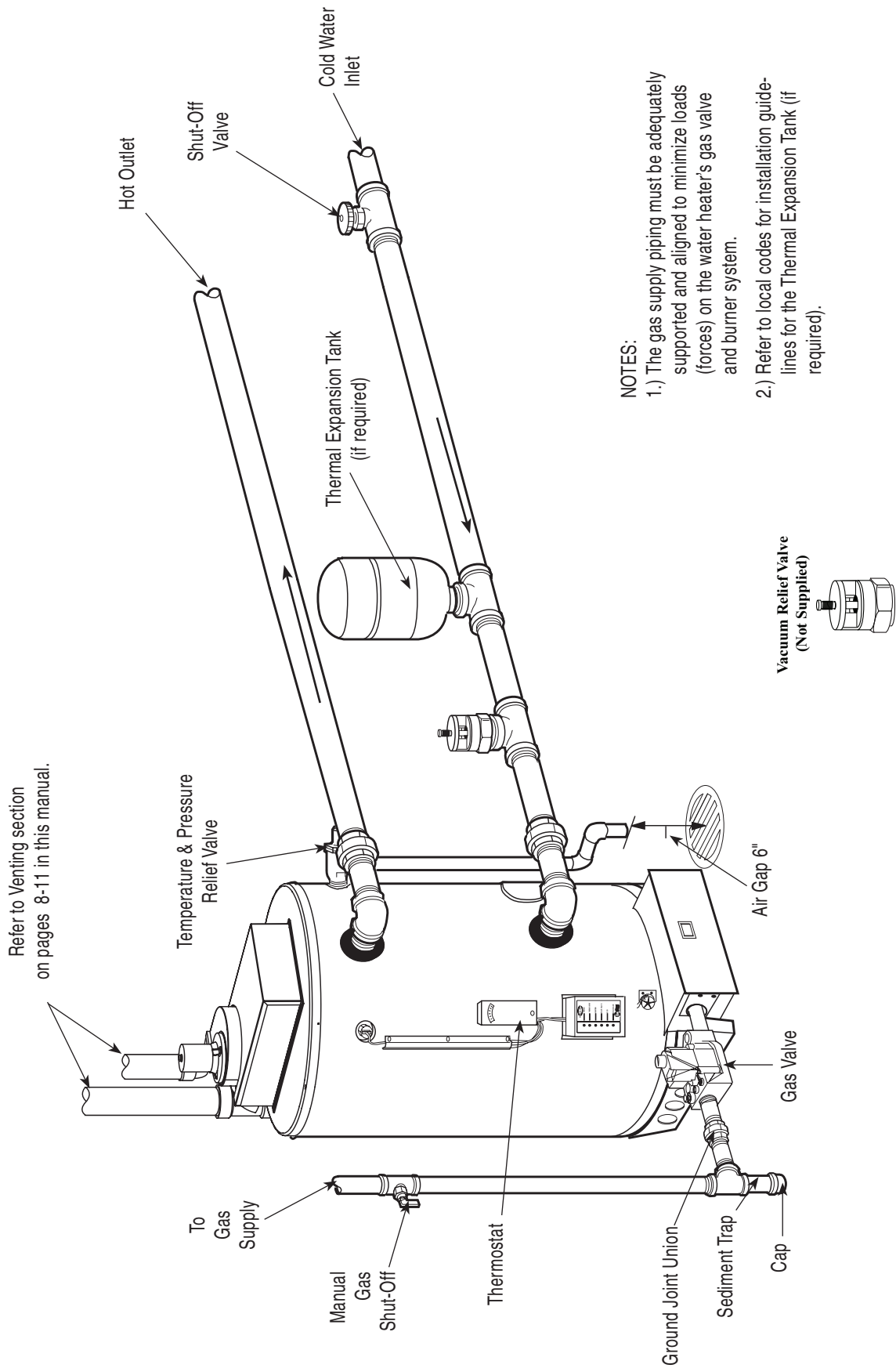

Installation

WARNING

NEVER use open flame to test for gas leaks, as bodily injury or property damage could result.

PRESSURE TESTING THE GAS SUPPLY SYSTEM — The water heater and its manual gas shut-off valve **MUST** be disconnected from the gas supply piping system during any high pressure testing of that system at pressures in excess of 1/2 psi (14" w.c. / 3.5 kPa).

The water heater **MUST** be isolated from the gas piping system by closing the manual gas shut-off valve during any pressure testing of the gas supply piping at pressures equal to or less than 1/2 psi (14" w.c. / 3.5 kPa).

5. VENTING —

WARNING

The water heater must be vented to the outdoors as described in these instructions. DO NOT connect this water heater to an existing Vent or Chimney it must be vented separately from all other appliances.

WARNING

Failure to properly vent the water heater to the outdoors as outlined above and in the following section can result in unsafe operation of the water heater causing bodily injury, explosion, fire or death.

WARNING

To avoid the risk of fire, explosion or asphyxiation from carbon monoxide, NEVER operate this water heater unless it is properly vented and has an adequate air supply for proper operation. The vent pipe must overlap a minimum of 1" on each connection. It is important that the vent pipe engages fully into any pipe fitting and be kept in that position until the adhesive has fully cured. DO NOT drill or punch holes in the plastic pipe or fittings.

NOTICE: This unit can be vented using only the following recommended pipe material. Use only 3- or 4-inch diameter pipe.

- PVC (Schedule 40, ASTM D-1785)
- CPVC (Schedule 40, ASTM F-441)
- ABS (Schedule 40, ASTM D-2661)

The fittings, other than the VENT TERMINAL, should be equivalent to the following:

- PVC (Schedule 40 DWV, ASTM D-2665)
- CPVC (Schedule 40 DWV, ASTM F-438)
- ABS (Schedule 40 DWV, ASTM D-2661)

The unit may be vented horizontally through a wall or vertically through the roof. Pipe runs must be adequately supported along both vertical and horizontal runs. Maximum unsupported span is recommended to be no more than 4 feet. It is imperative that the first hanger be located on the horizontal run immediately adjacent to the first 90-degree elbow from the vertical rise or at the blower outlet in the case of a horizontal blower position. Support method used should isolate the vent pipe from floor joists or other structural members to help prevent the transmission of noise and vibration. Do not support, pin or otherwise secure the venting system in a way that restricts the normal thermal expansion and contraction of the chosen venting material.

If the water heater is being installed as a replacement for an existing power vented water heater, a thorough inspection of the existing venting system must be performed prior to any installation work. Verify that the correct materials, as detailed above have been used, and that the minimum or maximum vent length and terminal locations as detailed in this manual have been met. Carefully inspect the entire venting system for any signs of cracks or fractures, particularly at the joints between elbows or other fittings and the straight runs of vent pipe. Check the system for signs of sagging or other stresses in the joints as a result of misalignment of any components in the system. If any of these conditions are found, they must be corrected in accordance with the venting instructions in this manual before completing the installation and putting the water heater into service.

VENT PIPE CONNECTION —

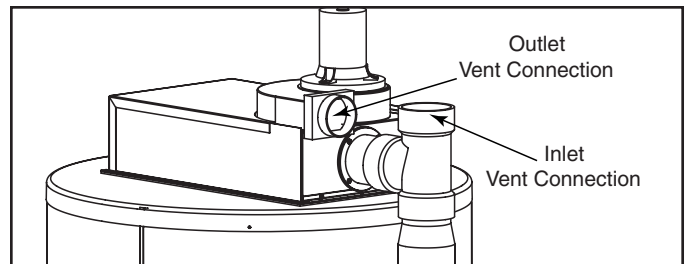

Figure 5. — Vent Pipe Connection Locations

The blower assembly is preinstalled at the factory, so all that is required for connecting the vent system is attaching the vent pipe to the blower and the PVC Tee. Before starting the vent installation, careful planning should be given to the routing and termination of the vent pipe. The length of the vent pipe (inlet and outlet) should be kept to a minimum. Also, see page 10 & 12 for vent terminal placement. The GP100-150 & GP100-200 model can be vented using either 3 inch or 4 inch Schedule 40 PVC pipe and fittings.

To use 3 inch PVC, you can connect directly to the blower outlet (rubber coupling provided for outlet connection) and PVC Tee. Make sure that clamps on rubber coupling are tight, after the pipe is installed. The inlet vent pipe should be cemented into the PVC Tee.

If 4 inch PVC pipe is going to be used, then it will be necessary to have a short piece (at least 3 inches long) of 3 inch PVC pipe to join into the coupling and tee. Then a 4 X 3 reducer would need to be joined to the short piece of pipe, so that the 4 inch pipe could be used. The 4 inch pipe will then need to be stepped back down, using a 4 X 3 reducer, to 3 inch PVC. To install the vent terminals, a short length of 3 inch (maximum of 16 inches long) pipe will need to be used. (Refer to Figure 9b on page 10.)

The GP100-250 model can only be vented using 4 inch Schedule 40 PVC pipe and fittings. The 4 inch pipe can be connected directly to the blower coupling and 4 inch tee.

MINIMUM AND MAXIMUM VENT LENGTHS

Charts are for installation from 0 - 2000 ft. elevation ONLY. (Please see supplement sheet for installations above 2000 feet.)

NOTICE: Be sure to mount inlet vent terminal 6 inches higher than the outlet vent terminal. Vent terminals need to be a minimum of 7 inches (center to center) horizontally apart and a maximum of 24 inches apart.

GP100-150 & GP100-200

Venting Information for 3" Vents

Number of 90° Elbows with Vent Terminal		Number of 45° Elbows	Minimum Pipe Length required (Ft)	Maximum Pipe Length (Ft)
Inlet Vent	Outlet Vent			
One (1)	One (1)	None	5.0	40.0
One (1)	One (1)	One (1)	2.5	37.5
Two (2)	Two (2)	None	5.0	35.0
Two (2)	Two (2)	One (1)	2.5	32.5
Three (3)	Three (3)	None	5.0	30.0
Three (3)	Three (3)	One (1)	2.5	27.5
Four (4)	Four (4)	None	5.0	25.0
Four (4)	Four (4)	One (1)	2.5	22.5

Vent lengths for the inlet and the outlet pipes should not have a difference of more than five (5) equivalent feet.

Venting Information for 4" Vents

Number of 90° Elbows with Vent Terminal		Number of 45° Elbows	Minimum Pipe Length Required (Ft)	Maximum Pipe Length (Ft)
Inlet Vent	Outlet Vent			
One (1)	One (1)	None	10.0	50.0
One (1)	One (1)	One (1)	9.5	47.5
Two (2)	Two (2)	None	5.0	45.0
Two (2)	Two (2)	One (1)	2.5	42.5
Three (3)	Three (3)	None	5.0	40.0
Three (3)	Three (3)	One (1)	2.5	37.5
Four (4)	Four (4)	None	5.0	35.0
Four (4)	Four (4)	One (1)	2.5	32.5

Vent lengths for the inlet and the outlet pipes should not have a difference of more than five (5) equivalent feet.

NOTICE: 3" and 4" vent pipe should not be mixed, other than to reduce the 4" vent for the 3" PVC Vent Terminal. This unit is supplied with two (2) 3-inch Schedule 40 PVC 45° vent terminals.

The 4" vent pipe can use up to 16 inches of 3" PVC, preceding the vent terminal. This unit uses the same vent terminals (supplied with the unit) for both 3" and 4" pipe. A 4" to 3" reducer will be required to go from 4" to 3" pipe.

GP100-250

Venting Information for 4" Vents

Number of 90° Elbows with Vent Terminal		Number of 45° Elbows	Minimum Pipe Length Required (Ft)	Maximum Pipe Length (Ft)
Inlet Vent	Outlet Vent			
One (1)	One (1)	None	10.0	45.0
One (1)	One (1)	One (1)	7.5	42.5
Two (2)	Two (2)	None	5.0	40.0
Two (2)	Two (2)	One (1)	2.5	37.5
Three (3)	Three (3)	None	5.0	35.0
Three (3)	Three (3)	One (1)	2.5	32.5
Four (4)	Four (4)	None	5.0	30.0
Four (4)	Four (4)	One (1)	2.5	27.5

Vent lengths for the inlet and the outlet pipes should not have a difference of more than five (5) equivalent feet.

GP100-250 can only be vented with four (4) inch PVC pipe and fittings. Use only the vent terminals supplied with the water heater

HORIZONTAL VENT TERMINAL LOCATION - The location of the vent terminal depends on the minimum clearances and considerations shown in the charts on pages 11 and 12..

Installation

GP100-150 & GP100-200

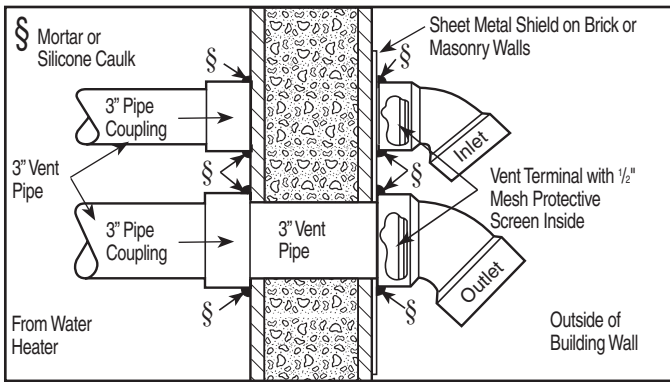

Figure 9a – Typical Horizontal 3” Vent Installation

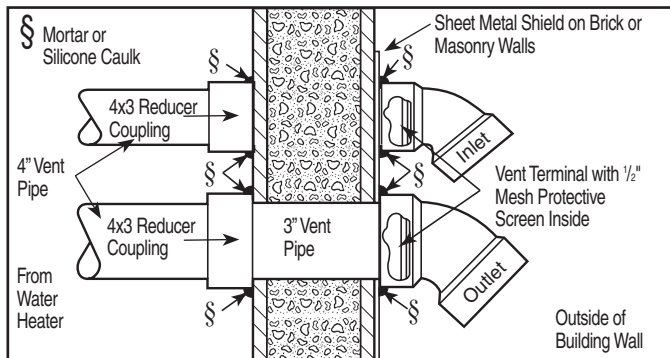

Figure 9b – Typical Horizontal 4” Vent Installation

GP100-250

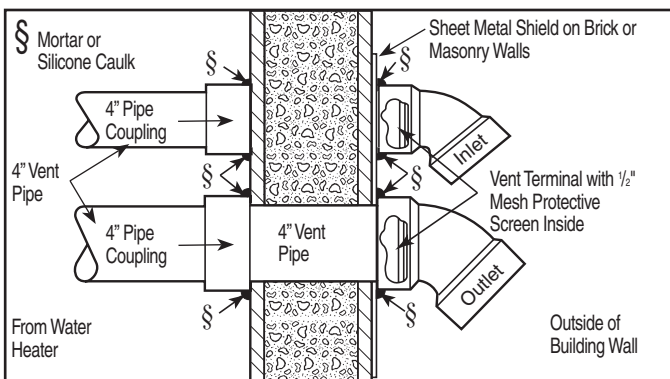

Figure 9c – Typical Horizontal 4” Vent Installation

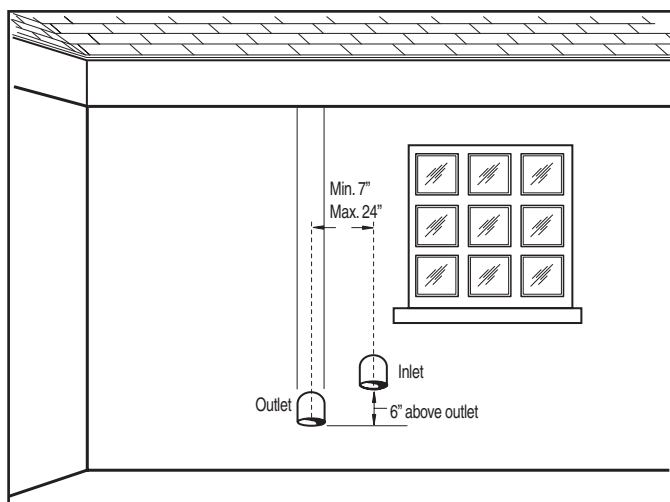

Figure 6

Additional Considerations (See Figure 9)

1. Do Not install vent terminal under any patio or deck.
2. To help prevent moisture from freezing on walls and under eaves, do not locate vent terminal on the side of a building with prevailing winter winds.
3. Do Not terminate vent pipe directly on brick or masonry surfaces. Use a rust-resistant sheet metal backing plate behind vent. (See Figure 9.)
4. Do Not locate vent terminal too close to shrubbery, since flue gases may damage them.
5. Caulk all cracks, seams and joints within six (6) feet of vent terminal.
6. All painted surfaces should be primed to lessen the chance of physical damage. Painted surfaces will require maintenance.
7. Insulate vent pipe exposed to cold conditions (attics, crawl spaces, etc.) to help prevent moisture from accumulating in vent pipe.

WARNING

Moisture in the flue gas will condense as it leaves the vent terminal. In cold weather this condensate can freeze on the exterior wall, under the eaves and on surrounding objects. Some discoloration to the exterior of the building is to be expected. However, improper location or installation can result in severe damage to the structure or exterior finish of the building.

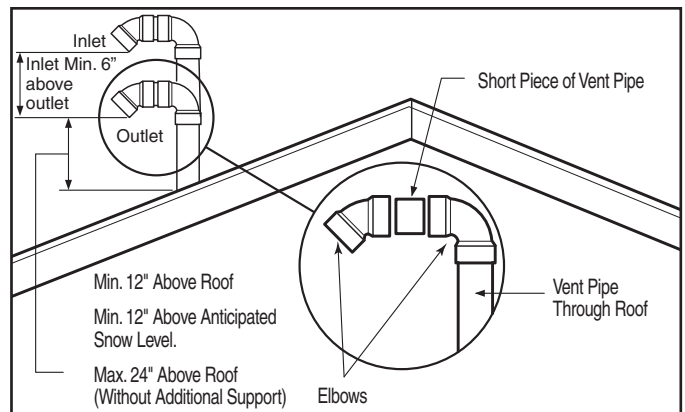

Figure 8 – Vertical Vent Terminal Location

HORIZONTAL VENT INSTALLATION – Once the vent terminal location has been determined, make a hole through the exterior wall to accommodate the vent pipe. Vent pipe must exit exterior wall horizontally only. (See Figures 9a and 9b.)

Insert a small length of vent pipe through the wall and connect the coupling as shown in Figure 9. Connect terminal as shown to the vent pipe on the exterior of the building. Seal any opening around the vent pipe or fittings with mortar or silicone caulk as shown in Figures 9a and 9b.

Complete the rest of the vent pipe installation to the water heater’s vent connector fitting on the blower outlet. If necessary support horizontal run as previously mentioned.

Installation

VERTICAL VENT INSTALLATION – Once the vent terminal location has been determined, make a hole through the roof and interior ceiling to accommodate the vent pipe. Complete the vent pipe installation to the water heater's vent connector fitting on the blower outlet. Support vertical or horizontal runs as previously mentioned.

Install adequate flashing where the vent pipe passes through the roof. Determine the vent terminal height and cut vent pipe accordingly. Refer to Fig. 8 for proper vent terminal height. Connect vent elbow onto vertical pipe through roof. Connect short piece of vent pipe (approximately 3" long) to elbow, then join terminal to the short piece of vent pipe.

VERTICAL VENT TERMINAL LOCATION – The location of vertical vent terminal depends on the following considerations (see Figure 8):

1. Minimum twelve (12) inches above roof.
2. Minimum twelve (12) inches above anticipated snow level.

3. Maximum twenty-four (24) inches above roof level without additional support for vent pipe.
4. Four (4) feet from any gable, dormer or other roof structure with building interior access (i.e., vent, window, etc.).
5. Ten (10) feet from any forced air inlet to the building. Any fresh or make-up air inlet such as a dryer or furnace area is considered to be a forced air inlet.
6. The inlet is a minimum of six (6) inches vertically above the outlet.
7. Terminals are a minimum of seven (7) inches horizontally apart with a maximum of twenty-four (24) inches.

VENT INSTALLATION – Before proceeding, make certain you understand the procedure and cautions covered in the section "Joining Pipes and Fittings."

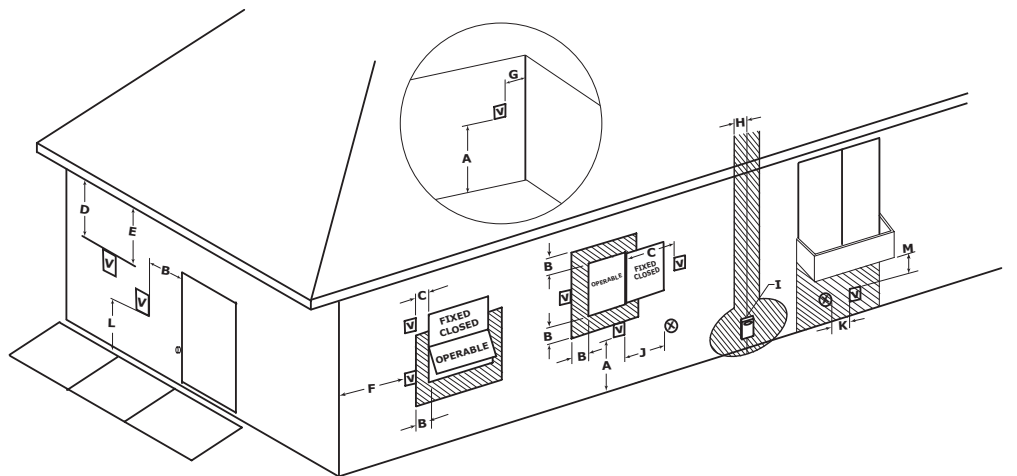

V VENT TERMINAL
 X AIR SUPPLY INLET
 AREA WHERE TERMINAL IS NOT PERMITTED

Horizontal Vent Terminal Location

The following information should be used for determining the proper location of the vent terminal for direct vent water heaters.

	Canadian Installations ¹	US Installations ²
A= Clearance above grade, veranda, porch, deck or balcony.	12 inches (30 cm) above anticipated snow level.	12 inches (30 cm) above anticipated snow level.
B= Clearance to window or door that may be opened.	6 inches (15 cm) for appliances ≤ 10,000 Btuh (3 kW), 12 inches (30 cm) for appliances > 10,000 Btuh (3kW) and ≤ 100,000 Btuh (30kW), 36 inches (91 cm) for appliances > 100,000 Btuh (30kW).	6 inches (15 cm) for appliances ≤ 10,000 Btuh (3 kW), 9 inches (23 cm) for appliances > 10,000 Btuh (3 kW) and ≤ 50,000 Btuh (15 kW), 12 inches (30 cm) for appliances > 50,000 Btuh (15 kW).
C= Clearance to permanently closed window.	*	*
D= Vertical Clearance to ventilated soffit located above the terminal within a horizontal distance of 2 feet (61 cm) from the center line of the terminal.	3 feet (91 cm)	3 feet (91 cm)
E= Clearance to unventilated soffit.	*	*
F= Clearance to outside corner.	*	*
G= Clearance to inside corner.	18 inches (46 cm)	18 inches (46 cm)

Figure 9 - Horizontal Vent Terminal Location

Canadian Installations ¹

US Installations ²

H = Clearance to each side of center line extended meter/regulator assembly above	3 feet (91 cm) within a height 15 feet (4.57 m) above the meter/regulator assembly.	*
I = Clearance to service regulator vent outlet.	3 feet (91 cm)	*
J = Clearance to nonmechanical air supply inlet to the combustion air inlet to any building or other appliance.	6 inches (15 cm) for appliances ≤ 10,000 Btuh (3 kW), 12 inches (30 cm) for appliances > 10,000 Btuh (3kW) and ≤ 100,000 Btuh (30kW), 36 inches (91 cm) for appliances > 100,000 Btuh (30kW).	4 feet (1.2 m) below or to side of opening; 1 foot (300 mm) above opening.
K = Clearance to mechanical air supply inlet.	6 feet (1.83 m)	3 feet (91 cm) above if within 10 feet (3 m) horizontally.
L = Clearance above paved side walk or paved driveway located on public property.	7 feet (2.13 m)	7 feet (2.13 m)
M = Clearance under veranda, porch, deck or balcony.	Not Allowed	Not Allowed

¹ In accordance with current CAN/CGA-B149 Installation Codes.

² In accordance with current ANSI Z223.1/ NFPA 54 National Fuel Gas Code.

+ A vent shall not terminate directly above a sidewalk or paved driveway that is located between two single family dwellings and serves both dwellings.

* If clearances are not specified then follow local installation codes and the requirement of the gas supplier.

DRAINING THE CONDENSATE – In certain conditions, installations in unconditioned space or having long horizontal or vertical runs may accumulate condensate. In order to prevent condensate from draining back into the blower, we recommend that it be drained. This unit is provided with a special fitting on the blower that allows for the draining of condensate formed in the vent. The drain hose should have two (2) loops formed, to act as traps. Before operation of the water heater, both loops should have water placed in them. Support the traps so that they remain horizontal. Condensate is known to be acidic; refer to local, state or federal codes for proper handling methods.

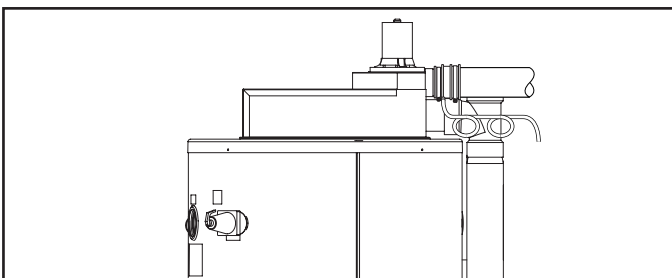

Figure 10 - Draining the Condensate

JOINING PIPES AND FITTINGS – All pipe, fittings, solvent cement, primers and procedures must conform to American National Standards Institute and American Society for Testing and Materials (ANSI/ASTM) standards.

CEMENTING JOINTS – All joints in the vent piping must be properly sealed and we recommend using the following material:

PVC materials should use ASTM D-2564 grade cement.
 CPVC materials should use ASTM F-493 grade cement.
 ABS materials should use ASTM D-2235 grade cement.

Cleaner-Primer and Medium Body Solvent Cement

1. Cut pipe end square, remove jagged edges and burrs. Chamfer end of pipe, then clean fitting socket and pipe joint area of all dirt, grease or moisture.
2. After checking pipe and socket for proper fit, wipe socket and pipe with cleaner-primer. Apply a liberal coat of primer to inside surface of socket and outside of pipe. Do not allow primer to dry before applying cement.
3. Apply a thin coat of cement evenly in the socket. Quickly apply a heavy coat of cement to the pipe end and insert pipe into fitting with a slight twisting motion until it bottoms out.
 NOTICE: Cement must be fluid; if not, recoat.
4. Hold the pipe fitting for 30 seconds to prevent the tapered socket from pushing the pipe out of the fitting.
5. Wipe all excess cement from the joint with a rag. Allow 15 minutes before handling. Cure time will vary according to fit, temperature and humidity.

NOTICE: Stir the solvent cement frequently while using. Use a natural bristle brush or the dauber supplied with the can. The proper brush size is one inch.

FOR PROPER INSTALLATION:

CAUTION

- **DO NOT use solvent cement that has become curdled, lumpy or thickened.**
- **DO NOT thin solvent cement. Observe shelf precautions printed on the containers.**
- **For applications below 32°F use only low temperature type solvent cement.**
- **Appropriate solvent and cleaner must be used for the type of vent pipe used (PVC, CPVC or ABS).**

WARNING

DANGER OF FIRE OR BODILY INJURY – Solvent cements and primers are highly flammable. Provide adequate ventilation and do not assemble near heat source or open flame. Do not smoke.

Avoid skin or eye contact. Observe all cautions and warnings on material containers.

6. **WIRING** — A polarized 120V 50/60 Hz power supply, with suitable disconnect means, must be connected to the black and white leads provided. The current draw by the Power Direct Vent unit is 1.5 Amps. The water heater, when installed, must be electrically grounded in accordance with local codes, or, in the absence of local codes, with the National Electrical Code, ANSI/NFPA 70 in the United States; or CSA C22.1 Electrical Code, in Canada. Refer to Fig. 14 on page 26 & 27 of this manual for water heater internal wiring diagrams.

NOTICE: DO NOT use in conjunction with a GFCI.

Installation Check List

A. Water Heater Location

- Close to area of vent.
- Indoors and protected from freezing temperatures.
- Proper clearance from combustible surfaces observed and water heater not installed on carpeted floor.
- Air supply free of corrosive elements and flammable vapors.
- Provisions made to protect area from water damage.
- Sufficient room to service heater.

B. Water Supply

- Water heater completely filled with water.
- Water heater and piping air vented.
- Water connections tight and free of leaks.

C. Gas Supply

- Gas line equipped with shut-off valve, union, and sediment trap/drip leg.
- Approved pipe joint compound used.
- Soap and water solution used to check all connections and fittings for possible gas leak.
- Gas Company inspected installation (if required).

D. Relief Valve

- Discharge line run to open drain.
- Discharge line protected from freezing.

E. Venting

- All pipe connections are secure (at blower, vent terminals and for each pipe joint connection)
- Vent terminals mounted properly and in correct location.
- Condensate tube has water in both loops.

TABLE 1
Maximum Capacity of Pipe in Cubic Feet of Gas per Hour for Gas Pressures of
-----0.5 psig or Less and a Pressure Drop of 0.3 Inch Water Column
Based on a 0.60 Specific Gravity Natural Gas; If 1.5 Specific Gravity L.P. Gas is used, multiply capacity by 0.63

Nominal Iron Pipe Size, Inches	Internal Diameter Inches	Length of Pipe, Feet													
		10	20	30	40	50	60	70	80	90	100	125	150	175	200
1/2	.622	132	92	73	63	56	50	46	43	40	38	34	31	28	26
3/4	.824	278	190	152	130	115	105	96	90	84	79	72	64	59	55
1	1.049	520	350	285	245	215	195	180	170	160	150	130	120	110	100
1 1/4	1.380	1,050	730	590	500	440	400	370	350	320	305	275	250	225	210
1 1/2	1.610	1,600	1,100	890	760	670	610	560	530	490	460	410	380	350	320
2	2.067	3,050	2,100	1,650	1,450	1,270	1,150	1,050	990	930	870	780	710	650	610
2 1/2	2.469	4,800	3,300	2,700	2,300	2,000	1,850	1,700	1,600	1,500	1,400	1,250	1,130	1,050	980
3	3.068	8,500	5,900	4,700	4,100	3,600	3,250	3,000	2,800	2,600	2,500	2,200	2,000	1,850	1,700
4	4.026	17,500	12,000	9,700	8,300	7,400	6,800	6,200	5,800	5,400	5,100	4,500	4,100	3,800	3,500

Operation

Before operating this water heater, be sure to read and follow the instructions on the label pictured below and all other labels on the water heater, as well as the warnings printed in this manual. Failure to do so can result in unsafe operation of the water heater resulting in property damage, bodily injury, or death. Should you have any problems reading or following the instructions in this manual, STOP, and get help from a qualified person.

1. LIGHTING PROCEDURE - Lighting procedures are outlined on the label pictured below. This label is also located on the water heater near the thermostat.

NOTICE: The Gas Valve supplied with this water heater may vary from the one pictured on the label below, but the Lighting Instructions are the same for all types of valves supplied with this model water heater.

FOR YOUR SAFETY READ BEFORE OPERATING

WARNING: If you do not follow these instructions exactly, a fire or explosion may result causing property damage, personal injury or loss of life

- A. This appliance is equipped with an ignition device which automatically lights the pilot. DO NOT try to light the pilot by hand.
- B. BEFORE OPERATING smell all around the appliance area for gas. Be sure to smell next to the floor because some gas is heavier than air and will settle on the floor.
- WHAT TO DO IF YOU SMELL GAS**
- Do not try to light any appliance
 - Do not touch any electrical switch; do not use any phone in your building.
 - Immediately call your gas supplier from a neighbor's phone. Follow the gas supplier's instructions.
- If you cannot reach your gas supplier, call the fire department.
- C. Use only your hand to turn the gas control knob. Never use tools. If the knob will not turn by hand, don't try to repair it, call a qualified service technician. Force or attempt to repair may result in a fire or explosion.
- D. Do not use this appliance if any part has been under water. Immediately call a qualified service technician to inspect the appliance and to replace any part of the control system and any gas control which has been under water.

OPERATING INSTRUCTIONS

1. STOP! READ THE SAFETY INFORMATION ABOVE ON THIS LABEL.
2. USING A SLOTTED SCREW DRIVER — INSERT INTO TEMPERATURE ADJUSTMENT OPENING. TURN SCREW CLOCKWISE TO THE LOWEST SETTING
3. TURN OFF ALL ELECTRIC POWER TO THE APPLIANCE.
4. THIS APPLIANCE IS EQUIPPED WITH AN IGNITION DEVICE WHICH AUTOMATICALLY LIGHTS THE PILOT. DO NOT TRY TO LIGHT THE PILOT BY HAND.
5. TURN THE "GAS COCK KNOB" CLOCKWISE TO "OFF."
6. WAIT FIVE (5) MINUTES TO CLEAR OUT ANY GAS. IF YOU THEN SMELL GAS, STOP! FOLLOW "B" IN THE SAFETY INFORMATION ABOVE ON THIS LABEL. IF YOU DON'T SMELL GAS, GO TO NEXT STEP.
7. TURN "GAS COCK KNOB" COUNTER-CLOCKWISE TO "ON".
8. TURN ON ALL ELECTRIC POWER TO THE APPLIANCE.
9. SET THERMOSTAT TO DESIRED SETTING
10. IF THE APPLIANCE WILL NOT OPERATE, FOLLOW THE INSTRUCTIONS "TO TURN OFF GAS TO APPLIANCE" AND CALL YOUR SERVICE TECHNICIAN OR GAS SUPPLIER.

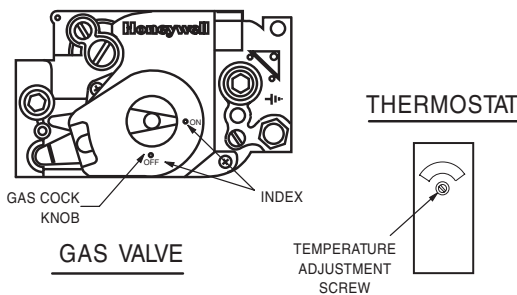

TO TURN OFF GAS TO APPLIANCE

1. SET THE THERMOSTAT TO LOWEST SETTING.
2. TURN OFF ALL ELECTRIC POWER TO THE APPLIANCE IF SERVICE IS TO BE PERFORMED.
3. TURN THE "GAS COCK KNOB" CLOCKWISE TO "OFF".

Operation

Before operating this water heater, be sure to read and follow the instructions on the label pictured below and all other labels on the water heater, as well as the warnings printed in this manual. Failure to do so can result in unsafe operation of the water heater resulting in property damage, bodily injury, or death. Should you have any problems reading or following the instructions in this manual, STOP, and get help from a qualified person.

1. LIGHTING PROCEDURE - Lighting procedures are outlined on the label pictured below. This label is also located on the water heater near the thermostat.

NOTICE: The Gas Valve supplied with this water heater may vary from the one pictured on the label below, but the Lighting Instructions are the same for all types of valves supplied with this model water heater.

FOR YOUR SAFETY READ BEFORE OPERATING

WARNING: If you do not follow these instructions exactly, a fire or explosion may result causing property damage, personal injury or loss of life.

- A. This appliance is equipped with an ignition device which automatically lights the pilot. **DO NOT** try to light the pilot by hand.
 - B. BEFORE OPERATING smell all around the appliance area for gas. Be sure to smell next to the floor because some gas is heavier than air and will settle on the floor.
WHAT TO DO IF YOU SMELL GAS
 - Do not try to light any appliance
 - Do not touch any electric switch; do not use any phone in your building.
 - Immediately call your gas supplier from a neighbor's phone. Follow the gas supplier's instructions.
 - C. Use only your hand to turn the gas control knob. Never use tools. If the knob will not turn by hand, don't try to repair it, call a qualified service technician. Force or attempted repair may result in a fire or explosion.
 - D. Do not use this appliance if any part has been under water. Immediately call a qualified service technician to inspect the appliance and to replace any part of the control system and any gas control which has been under water.
- If you cannot reach your gas supplier, call the fire department.

OPERATING INSTRUCTIONS

1. STOP! READ THE SAFETY INFORMATION ABOVE ON THIS LABEL.
2. REMOVE OUTER COVER. USING A SLOTTED SCREWDRIVER - INSERT INTO SLOT IN CENTER OF DIAL. TURN DIAL COUNTERCLOCKWISE TO THE LOWEST SETTING.
3. TURN OFF ALL ELECTRIC POWER TO THE APPLIANCE.
4. THIS APPLIANCE IS EQUIPPED WITH AN IGNITION DEVICE WHICH AUTOMATICALLY LIGHTS THE PILOT. **DO NOT** TRY TO LIGHT THE PILOT BY HAND.
5. TURN THE "GAS CONTROL KNOB" CLOCKWISE TO "OFF".
6. WAIT FIVE (5) MINUTES TO CLEAR OUT ANY GAS. IF YOU THEN SMELL GAS, STOP! FOLLOW "B" IN THE SAFETY INFORMATION ABOVE ON THIS LABEL. IF YOU DON'T SMELL GAS, GO TO NEXT STEP.
7. TURN THE "GAS CONTROL KNOB" COUNTERCLOCKWISE TO "ON".
8. TURN ON ALL ELECTRIC POWER TO THE APPLIANCE.
9. SET THERMOSTAT TO DESIRED SETTING. INSTALL OUTER COVER.
10. IF THE APPLIANCE WILL NOT OPERATE, FOLLOW THE INSTRUCTIONS "TO TURN OFF GAS TO APPLIANCE" AND CALL YOUR SERVICE TECHNICIAN OR GAS SUPPLIER.

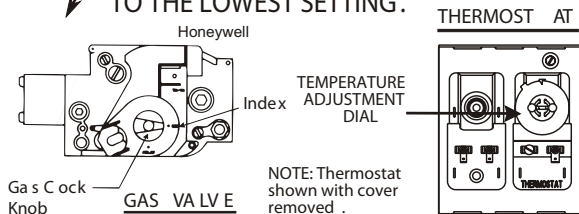

TO TURN OFF GAS TO APPLIANCE

1. TURN OFF ALL ELECTRIC POWER TO THE APPLIANCE IF SERVICE IS TO BE PERFORMED.
2. SET THE THERMOSTAT TO LOWEST SETTING.
3. TURN THE "GAS CONTROL KNOB" CLOCKWISE TO "OFF".

Operation

SAFETY PRECAUTIONS

- A. Do not turn off manual gas shut-off valve if water heater has been subjected to over heating, fire, flood, physical damage or if gas supply fails to shut off.
- B. Do Not turn on water heater unless it is filled with water.
- C. Do Not turn on water heater if cold water supply shut-off valve is closed.
- D. Do Not store or use gasoline or other flammable vapors and liquids, such as adhesives or paint thinner, in vicinity of this or any other appliance. If such flammables must be used, open doors and windows for ventilation, and all gas burning appliances in vicinity should be shut off, including their pilot lights, to avoid vapors igniting.

NOTICE: Flammable vapors may be drawn by air currents from surrounding areas to the water heater.

- E. Do not allow combustible materials such as newspaper, rags or mops to accumulate near water heater.
- F. If there is any difficulty in understanding or following the OPERATION or MAINTENANCE instructions, it is recommended that a qualified person or serviceman perform the work.

CAUTION

Hydrogen gas can be produced in a hot water system served by this water heater that has not been used for a long period of time (generally two weeks or more). **HYDROGEN GAS IS EXTREMELY FLAMMABLE!!** To dissipate such gas and to reduce risk of injury, it is recommended that the hot water faucet be opened for several minutes at the kitchen sink before using any electrical appliance connected to the hot water system. If hydrogen is present, there will probably be an unusual sound such as air escaping through the pipe as the water begins to flow. Do not smoke or use an open flame near the faucet at the time it is open.

WARNING

When this water heater is supplying general purpose hot water requirements for individuals, a thermostatically controlled mixing valve for reducing point of use water temperature is recommended. Contact a licensed plumber or the local plumbing authority for further information.

Outlet water temperature will vary during normal operating cycles. Reliable temperature readings should be taken shortly after main burner cycles off during a period of little or no use.

- 3. GAS MANIFOLD PRESSURE — With the gas valve supplied with this water heater, main burner ignition occurs at a low or step manifold pressure, which will then automatically build up to its normal operating level. The rated operating manifold pressure is listed on the water heater rating plate. For purposes of input adjustment, the minimum inlet gas pressure (with main burner on) is also shown on the rating plate. A 1/8" NPT tapping is provided on the outlet side of the gas valve for connecting a manometer to check this pressure. If necessary, adjust the pressure to the proper value by turning regulator adjustment screw clockwise to increase pressure or counterclockwise to decrease pressure.

- 4. CHECK INPUT — Consult the local Gas Company to determine the heating value of the gas supplied. Check input by clocking gas meter with all other gas appliances turned off. Use the following formula:

$$\text{INPUT (btu/h)} = \frac{(3,600) \times (\text{Heating Value}) \times (\text{Number of Cubic Feet Timed})}{\text{Seconds Clocked}}$$

WARNING

DO NOT exceed Input shown on the water heater's rating plate!

- 2. TEMPERATURE SETTINGS — The thermostat is adjusted to its lowest temperature position when shipped from the factory. To meet commercial water use needs, it is adjustable up to 180°F (82°C). However, water temperatures over 125°F (52°C) can cause severe burns instantly or death from scalds. This is the preferred starting point for setting the control for supplying general purpose hot water.

Safety and energy conservation are factors to be considered when setting the water temperature on the thermostat. The most energy efficient operation will result when the temperature setting is the lowest that satisfies the needs consistent with the application.

Hotter water increases the Potential for Hot Water SCALDS.

DANGER

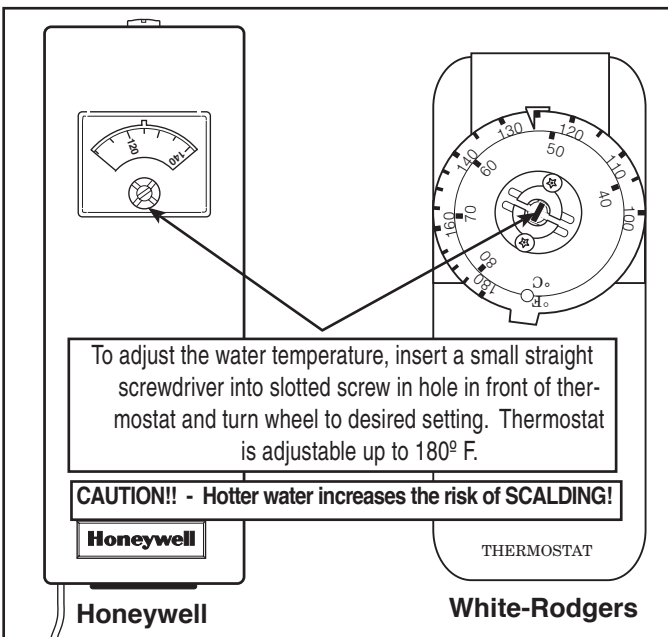

Figure 11. — Thermostat adjustment

Operation

To insure accuracy for rating, clock enough cubic feet of gas so that the clocked time is at least 60 seconds.

Small adjustments can be made by varying the manifold pressure from the designated settings mentioned above.

5. INTERMITTENT PILOT FLAME ADJUSTMENT — No adjustment is required with normal inlet gas pressures. The pilot flame adjustment valve is pre-set, and does not normally require re-adjustment.
6. HIGH ALTITUDE — Ratings of gas appliances are based on installation and operation at sea level of elevations of 2000 feet. Factory prepared high altitude models are available and are specifically rated for installation at elevation up to 8000 feet. Refer to rating plate on the front of the water heater for number and altitude specifications. Also refer to the supplement sheet for information on venting high altitude models.

7. EMERGENCY SHUTDOWN —

⚠ WARNING

Should overheating occur or the gas supply fail to shut off, turn off the manual gas control valve to the appliance.

⚠ WARNING

DO NOT use this appliance if any part has been under water. Immediately call a qualified service technician to inspect the appliance and to replace any part of the control system and any gas control which has been under water.

If the water heater has been subjected to fire or physical damage, turn off gas at the manual gas control (shut-off) valve. Do not operate the water heater again until it has been checked out by a qualified service technician.

Maintenance

Properly maintained, this water heater will provide years of dependable, trouble free service. It is strongly suggested that a regular routine maintenance program be established and followed by the owner. It is further recommended that a periodic inspection of the blower, thermostat, burner, relief valve, internal flueway, draft hood / damper assembly and venting system should be made by service technicians qualified in gas appliance repair.

1. ROUTINE PREVENTIVE MAINTENANCE

- A. BURNERS — Visually inspect the main burner flame and the pilot flame at least every three months. Refer to Figures 12 and 13 for normal flame pattern. Fallen scale can usually be dislodged from the tops of the burners with a thin rod, then vacuumed or brushed from the bottom of the burner box. If a more thorough cleaning is deemed necessary to restore a normal flame pattern, the burner tray assembly should be removed and the burners cleaned individually.

⚠ CAUTION

For your safety, removal and cleaning of burner tray and individual burners should be performed ONLY by a qualified service technician, as it involves disconnection of gas piping and leak testing.

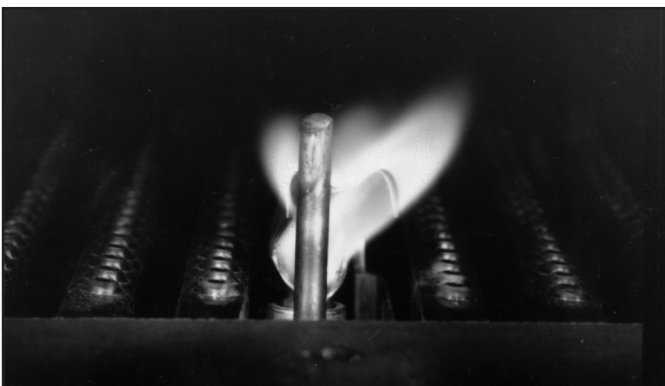

Figure 12. — Pilot Flame Pattern

TO REMOVE BURNER TRAY:

1. Turn off manual gas shut-off valve.
 2. Disconnect gas pipe union and wiring to gas valve and pilot.
 3. Remove retaining screws from plate on the same side as the gas valve.
 4. Slide burner tray assembly out. When reinstalling the burner tray assembly, make certain it is pushed in all the way so that the plate lines up with the holes in the plenum side. Then reinstall the retaining screws.
 5. Reconnect gas pipe union and wiring to gas valve and pilot, turn on manual gas shut-off valve and test for gas leak.
- B. VENTING SYSTEM — Inspect venting system at least yearly to make certain the passageways are free and unobstructed, and that the vent connector from the water heater's blower assembly is properly positioned and securely attached. Remove any obstructions in vent connector or vent terminal.
 - C. CONTROLS — The manifold pressure and controls should be checked at least yearly by a qualified service technician.

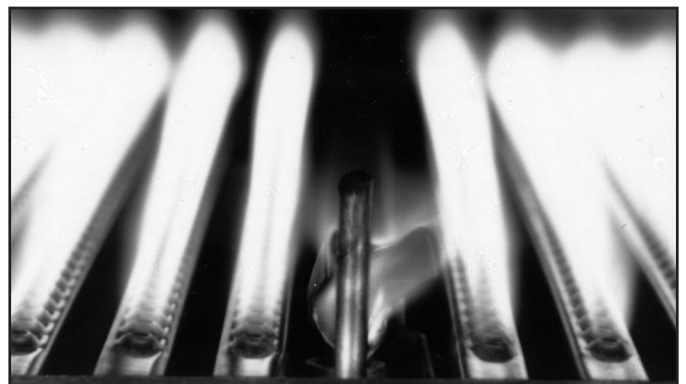

Figure 13. — Pilot & Main Burner Flame Pattern

Maintenance

- D. BLOWER — Clean the blower periodically to remove any buildup of lint or dirt. Remove the inlet plate and blow out any lint or dirt on the wheel and on the screen of the inlet plate. Before operation, re-install the inlet plate to the blower.
- E. PRESSURE SWITCH — Inspect the inlet to the pressure switch and the tubing for debris or blockage. Clean out the tubing periodically to prevent buildup of debris.
- F. EMERGENCY CUT-OFF — This water heater is equipped with a combination thermostat/temperature limiting device (ECO) that should be checked annually by qualified service personnel.
- G. THERMAL CUTOFF SWITCH — Some units are equipped with a thermal cutoff switch which will shut down the unit if the flue gas temperature is above permissible limits. The switch is a manual reset type.

CAUTION

Label all wires prior to disconnection when servicing controls. Wiring errors can cause improper and dangerous operation. VERIFY PROPER OPERATION AFTER SERVICING!

- G. RELIEF VALVE — The Temperature and Pressure Relief Valve must be free to operate properly. Check (at least once a year) by lifting the handle fully and allowing several gallons of water to flush through the discharge line. Make certain the discharged water is directed to a suitable drain.

DANGER

Before manually operating the relief valve, make certain no one will be exposed to the danger of coming in contact with the hot water released by this valve. The water may be hot enough to create a SCALD hazard. The water released should be directed to a suitable drain to prevent injury or damage.

NOTICE: If the temperature and pressure relief valve on the water heater discharges periodically, this may be due to thermal expansion in a "closed" water system. Contact the water supplier or local plumbing inspector on how to correct this. DO NOT plug the relief valve outlet.

- H. TANK— Good maintenance requires that the tank be cleaned of deposits. Unless the water supply is soft (0 to 5 grains hardness), scale or lime deposits will accumulate in the tank. Hard water scale is deposited at an increasingly high rate in proportion to increased water temperature. Accumulation of these deposits may reduce efficiency, and shorten the life of the water heater.

Any new installation should have a tank inspection program set up initially for frequent inspection. The first inspection should be within a six month period. Once the scaling tendencies have been established, the inspection program can be modified to suit the water conditions. Cleaning should be performed if the scale has accumulated above the drain valve opening.

A wet-dry shop vac with a nozzle fashioned from 1" and/or 3/4" polyethylene pipe makes a good tool for scraping and removing scale.

TO CLEAN OR INSPECT TANK:

1. Shut off gas valve and drain tank.
2. Remove tank clean-out cover on jacket and with pocket knife cut and remove a circular plug of insulation the full size of jacket opening.
3. Loosen nut on seal plate assembly enough to twist yoke sideways. Hold assembly securely and push inward, then remove from tank.
4. Remove as much built-up scale from flue tubes and tank bottom as practical. Do not attempt to clean so thoroughly that the tool used damages the glass lining.
5. Clean the seal plate and install a new gasket. Wipe clean the interior surface of the tank that contacts the gasket. Reinstall the seal plate and tighten in position. Fill tank with water and check for leaks. If no leaks are found, install insulation plug and clean-out cover on jacket and re-light the water heater.

If chemical lime dissolving cleaners are preferred, cautiously follow the instructions supplied with the cleaner. DO NOT use a muriatic or hydrochloric acid (HCl) base cleaner.

2. ANODE INSPECTION — The water supply in certain areas contains very aggressive elements. In these areas, periodic inspection of the anode is recommended to determine if replacement is necessary. The anode(s) supplied in this water heater is slowly consumed, thereby eliminating or minimizing corrosion and protecting the glass lined tank. The anode(s) should be replaced when more than 6 inches (15 cm) of core wire is exposed at either end.
3. SEASONAL OPERATION — If the water heater is to remain idle for an extended period (60 days or more) the heater should be turned off. The water heater and piping should be drained if they might be subjected to freezing temperatures. It is recommended that the water heater's operation is thoroughly checked (by a qualified service technician) before it is placed back in service. NOTICE: Refer to Hydrogen Gas caution notation on page 16.

“System Sentinel” Diagnostic System

The “System Sentinel” Diagnostic system on this water heater provides the user or service technician with a visual representation of the operational status of the various sections of the water heater’s control system. A quick glance at the System Sentinel panel on the front of the heater will give an indication of where to begin trouble shooting of a non operational heater.

The LED’s (light emitting diodes) on the panel are arranged from top to bottom based on their function in the normal sequence of operation, and their function is explained as follows:

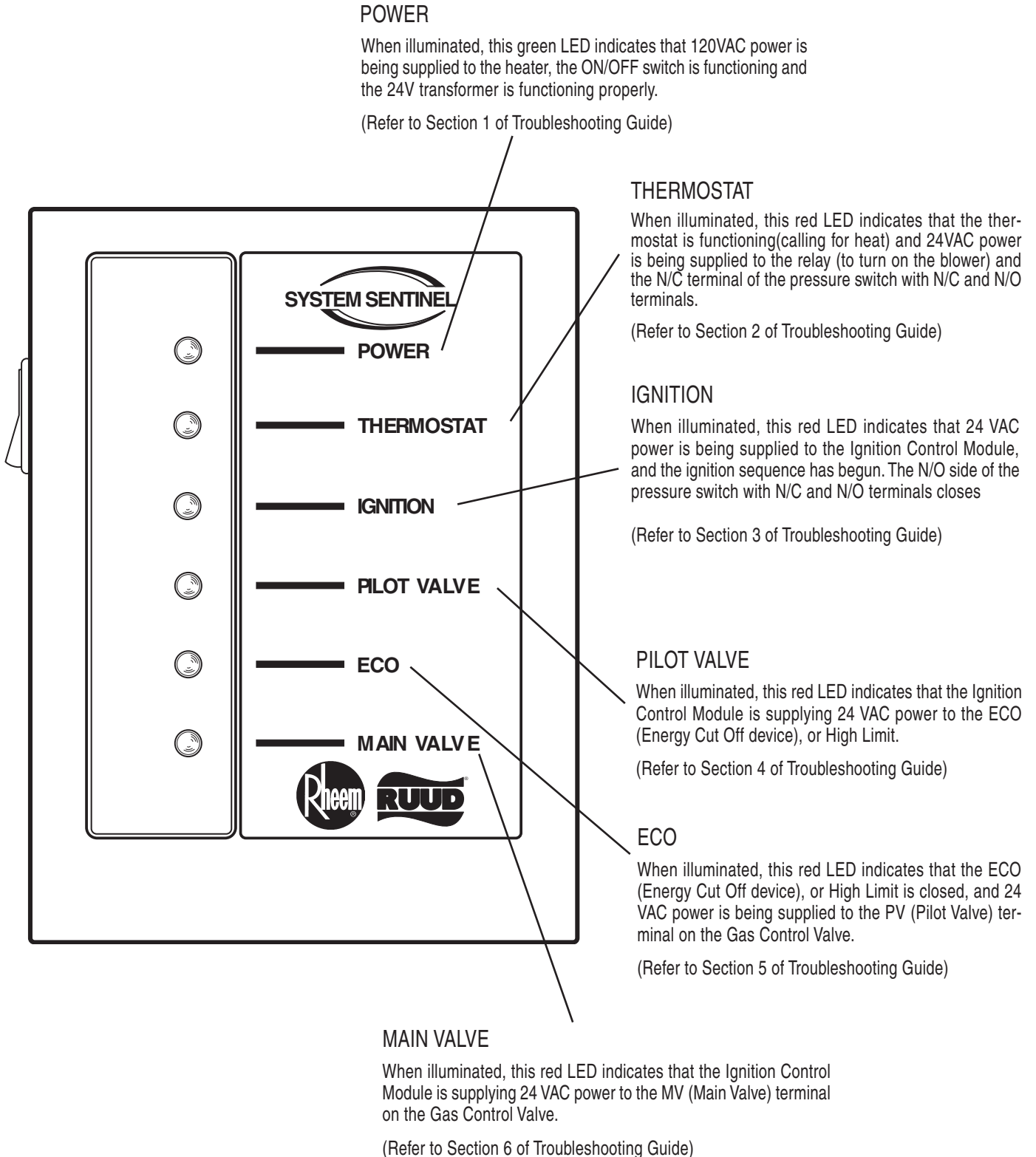

“System Sentinel” Troubleshooting Guide

Section 1... the “POWER” LED

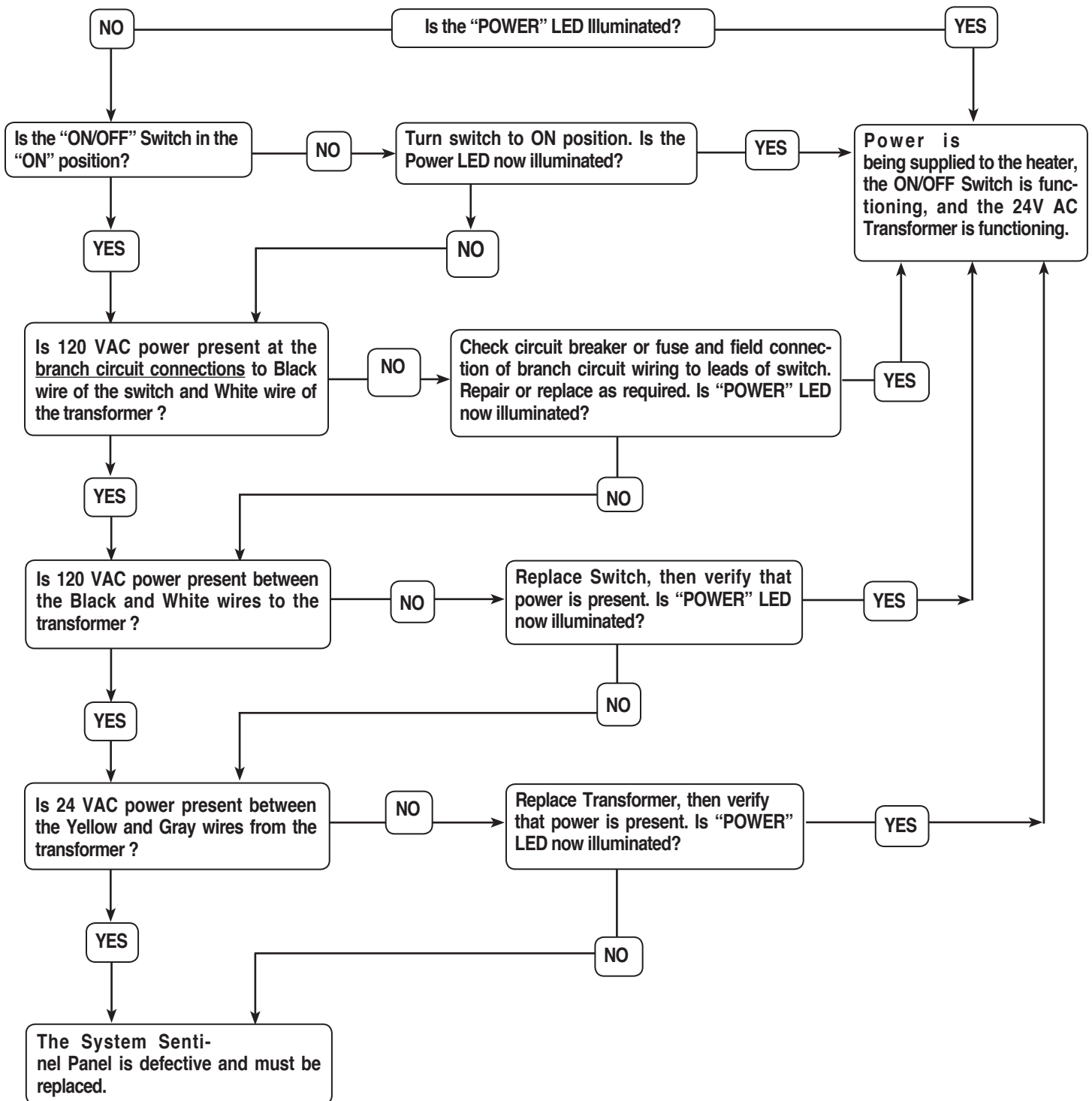

CAUTION

Label all wires prior to disconnection when servicing controls. Wiring errors can cause improper and dangerous operation. VERIFY PROPER OPERATION AFTER SERVICING!

“System Sentinel” Troubleshooting Guide

Section 2... the “THERMOSTAT” LED

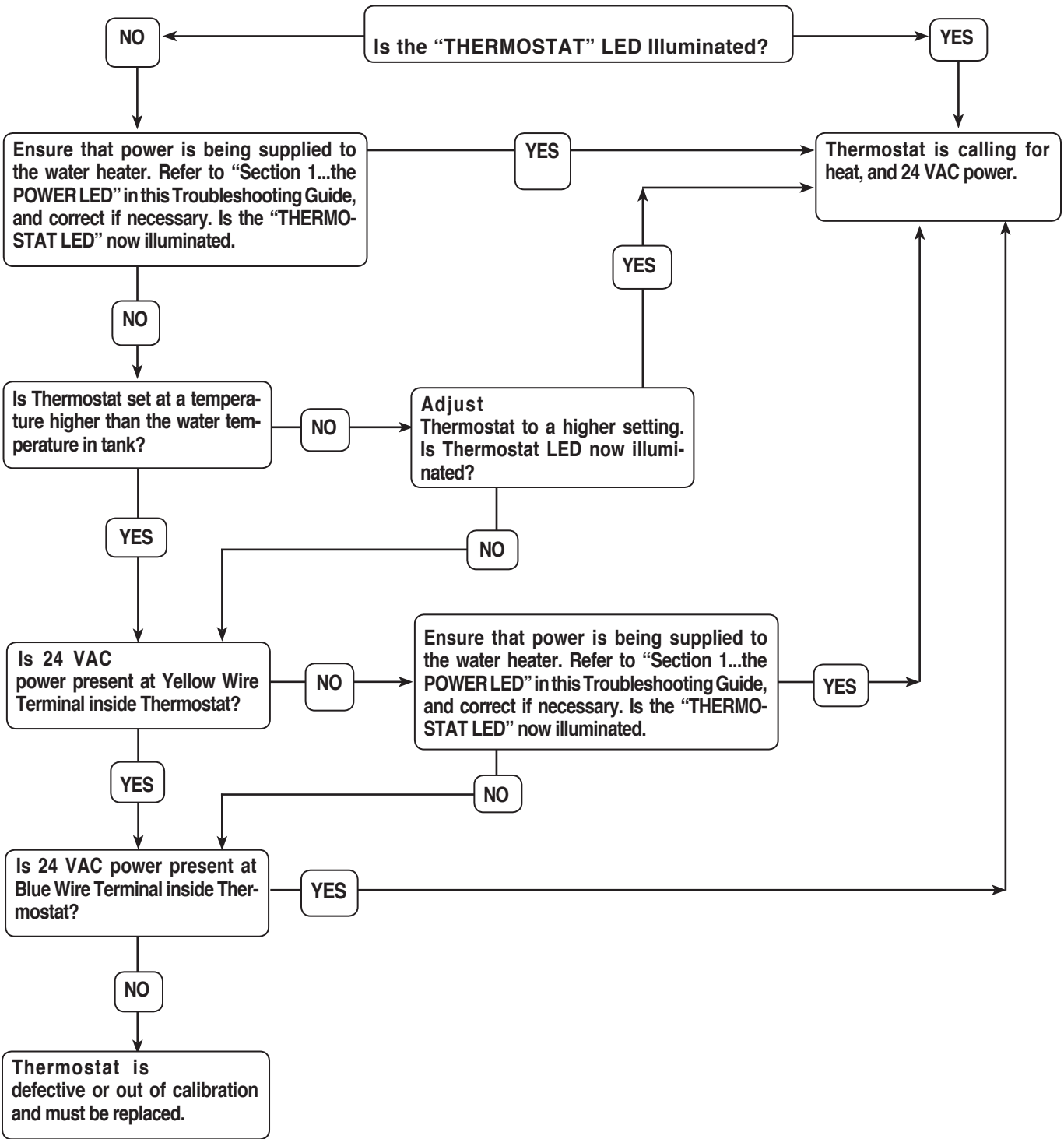

CAUTION

Label all wires prior to disconnection when servicing controls. Wiring errors can cause improper and dangerous operation. VERIFY PROPER OPERATION AFTER SERVICING!

“System Sentinel” Troubleshooting Guide

Section 4... the “PILOT VALVE” LED

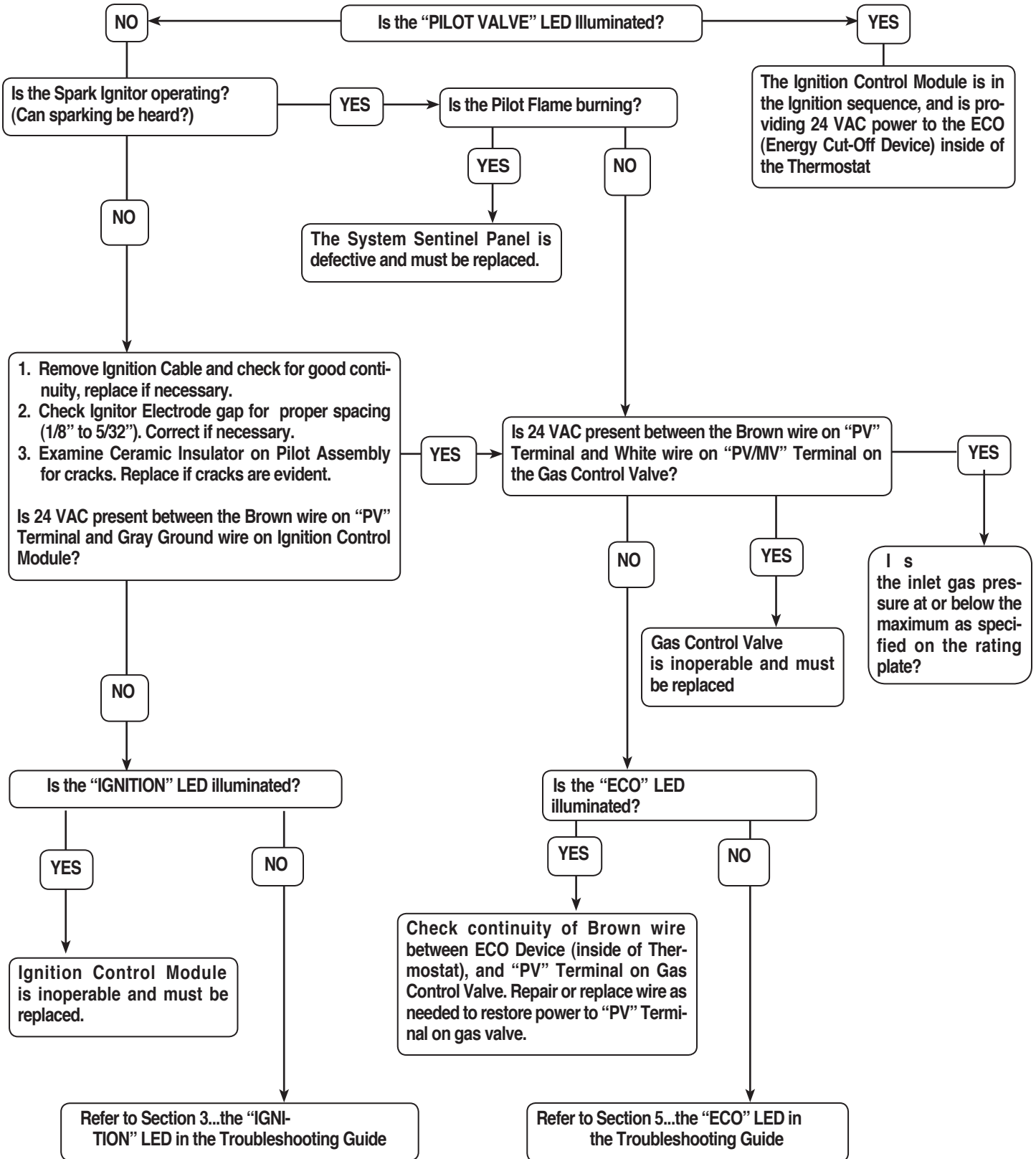

Label all wires prior to disconnection when servicing controls. Wiring errors can cause improper and dangerous operation. VERIFY PROPER OPERATION AFTER SERVICING!

“System Sentinel” Troubleshooting Guide

Section 5... the “ECO” LED

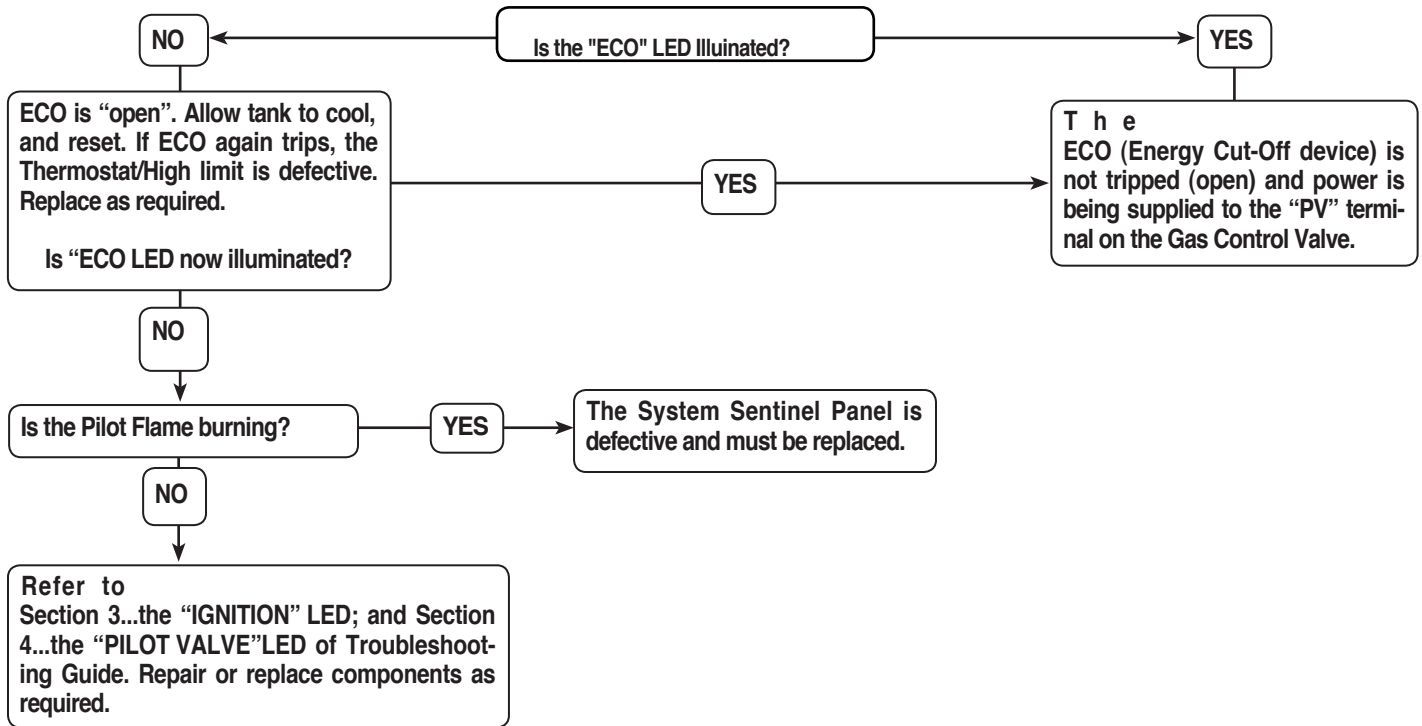

Section 6... the “MAIN VALVE” LED

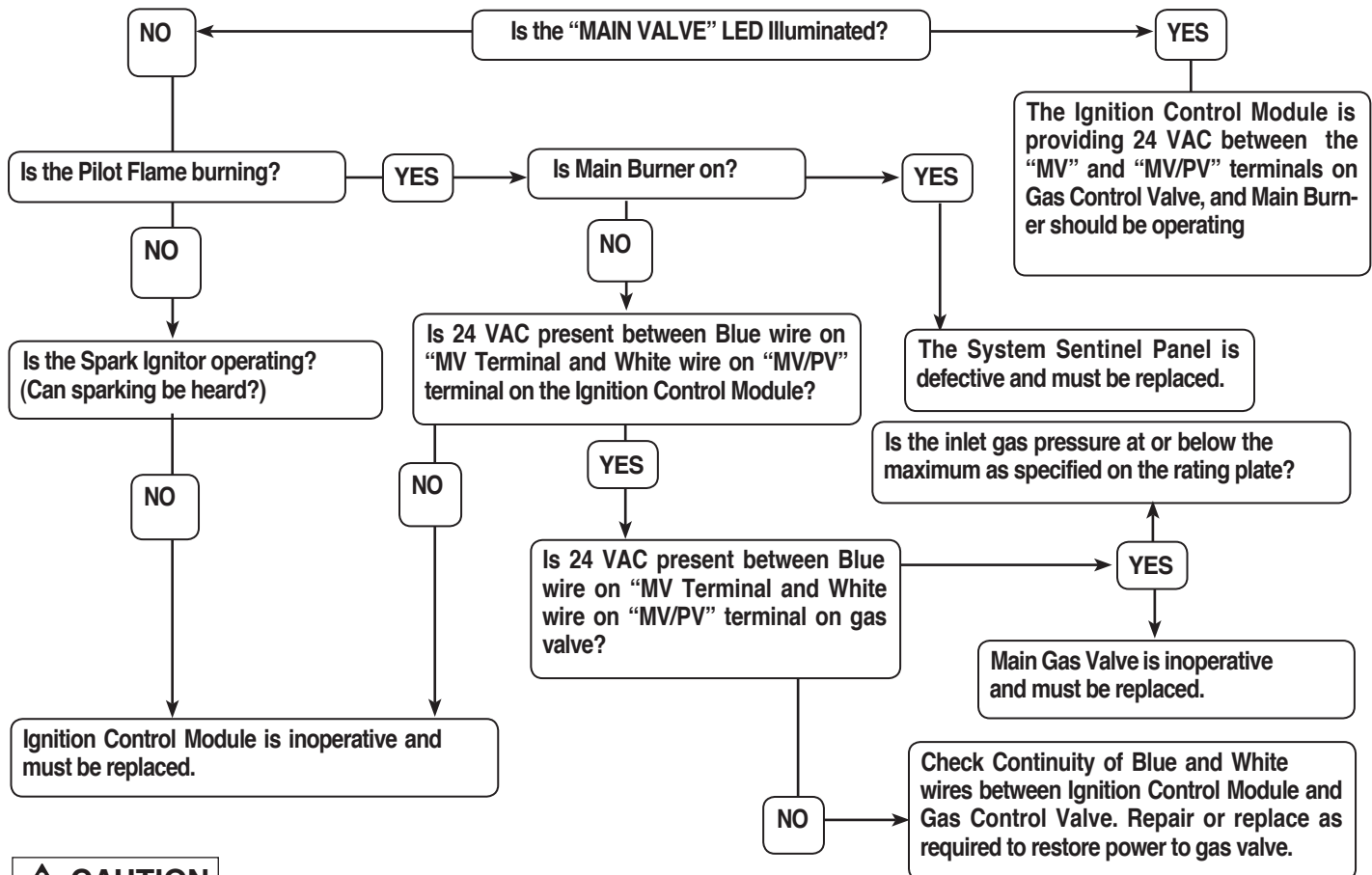

CAUTION

Label all wires prior to disconnection when servicing controls. Wiring errors can cause improper and dangerous operation. VERIFY PROPER OPERATION AFTER SERVICING!

Replacement Parts

INSTRUCTIONS FOR PLACING A PARTS ORDER

All parts orders should include:

The model and serial number of the water heater from the rating plate.

Specify type of gas (natural or LP) as marked on the rating plate.

Part description (as noted below) and number of parts desired.

⚠ CAUTION: For your safety **DO NOT** attempt repair of gas piping, gas control (thermostat), burners, vent connectors or other safety devices. Refer repairs to qualified service personnel.

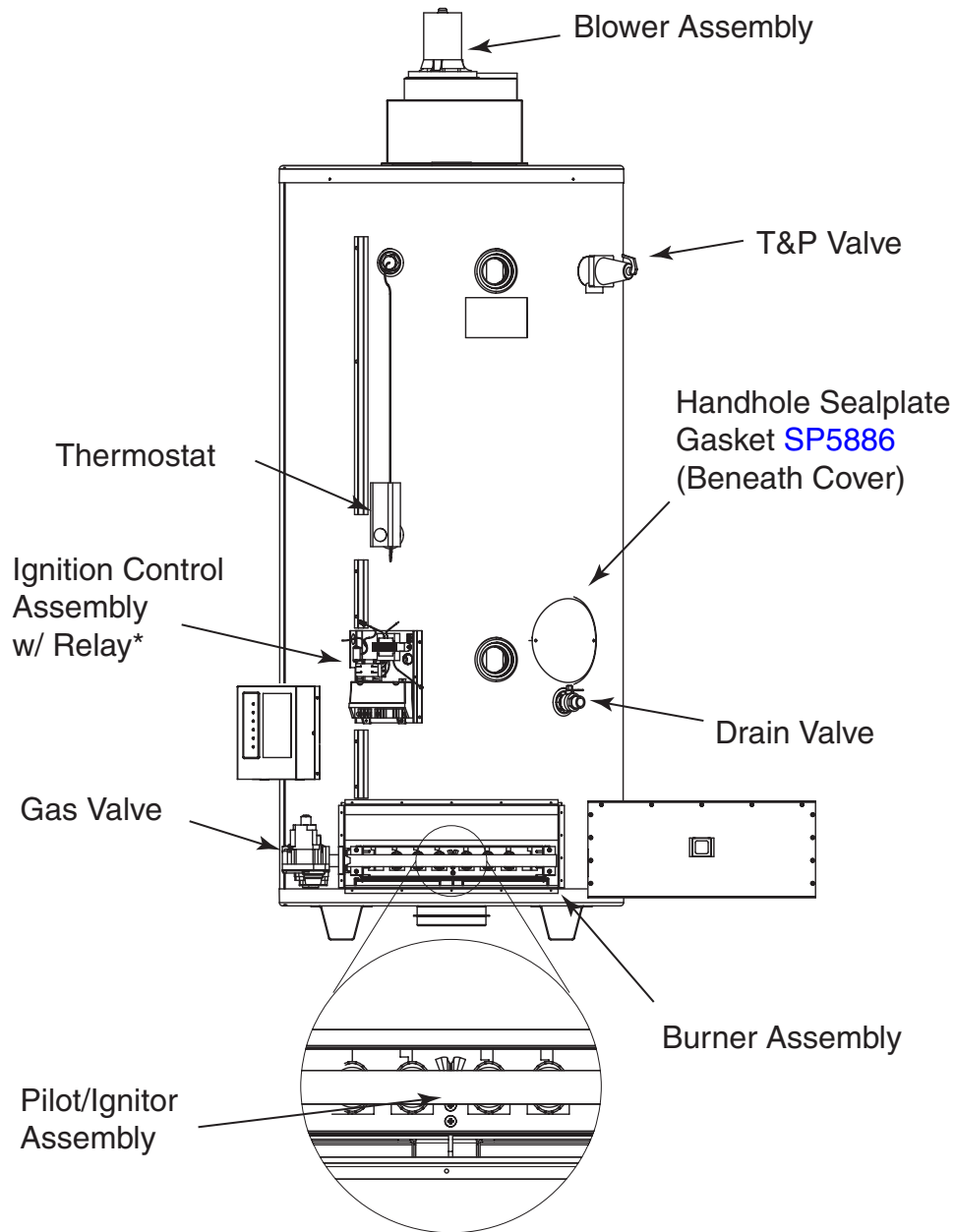

*Some assembly components are available individually (Control Module, Transformer, and ON/OFF Switch).

Wiring and Schematic Diagrams

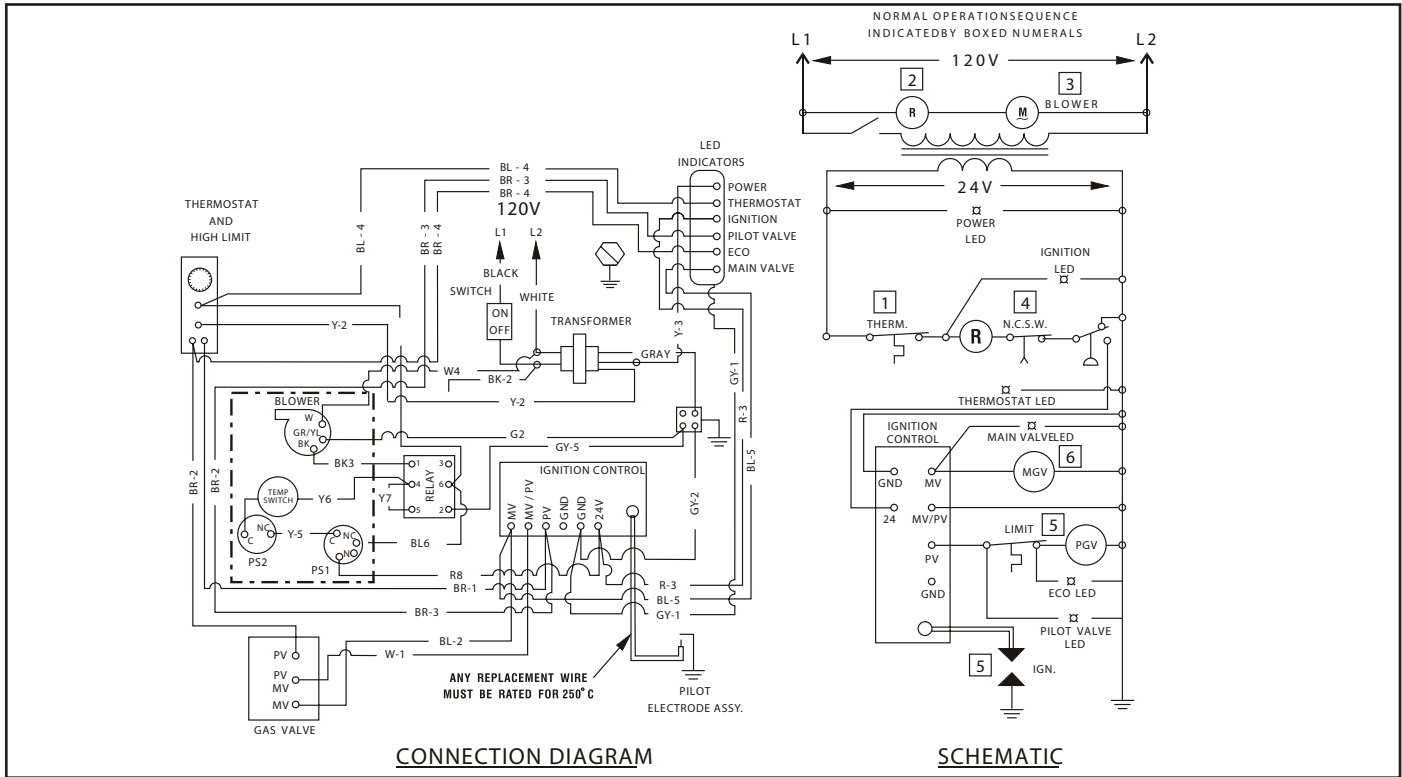

Figure 14. — Diagrams for units supplied with Honeywell VR8304P or VR8304M Gas Valve and Honeywell S8600M Ignition Control, Honeywell Thermostat and Temperature Limiting Switch for vent pipe..

NOTICE: If any of the original wire as supplied with this appliance must be replaced, it **MUST** be replaced with 18 GA., 600V, 105°C wire or its equivalent, unless otherwise noted.

CAUTION! Label all wires prior to disconnection when servicing controls. Wiring errors can cause improper and dangerous operation. **VERIFY PROPER OPERATION AFTER SERVICING!**

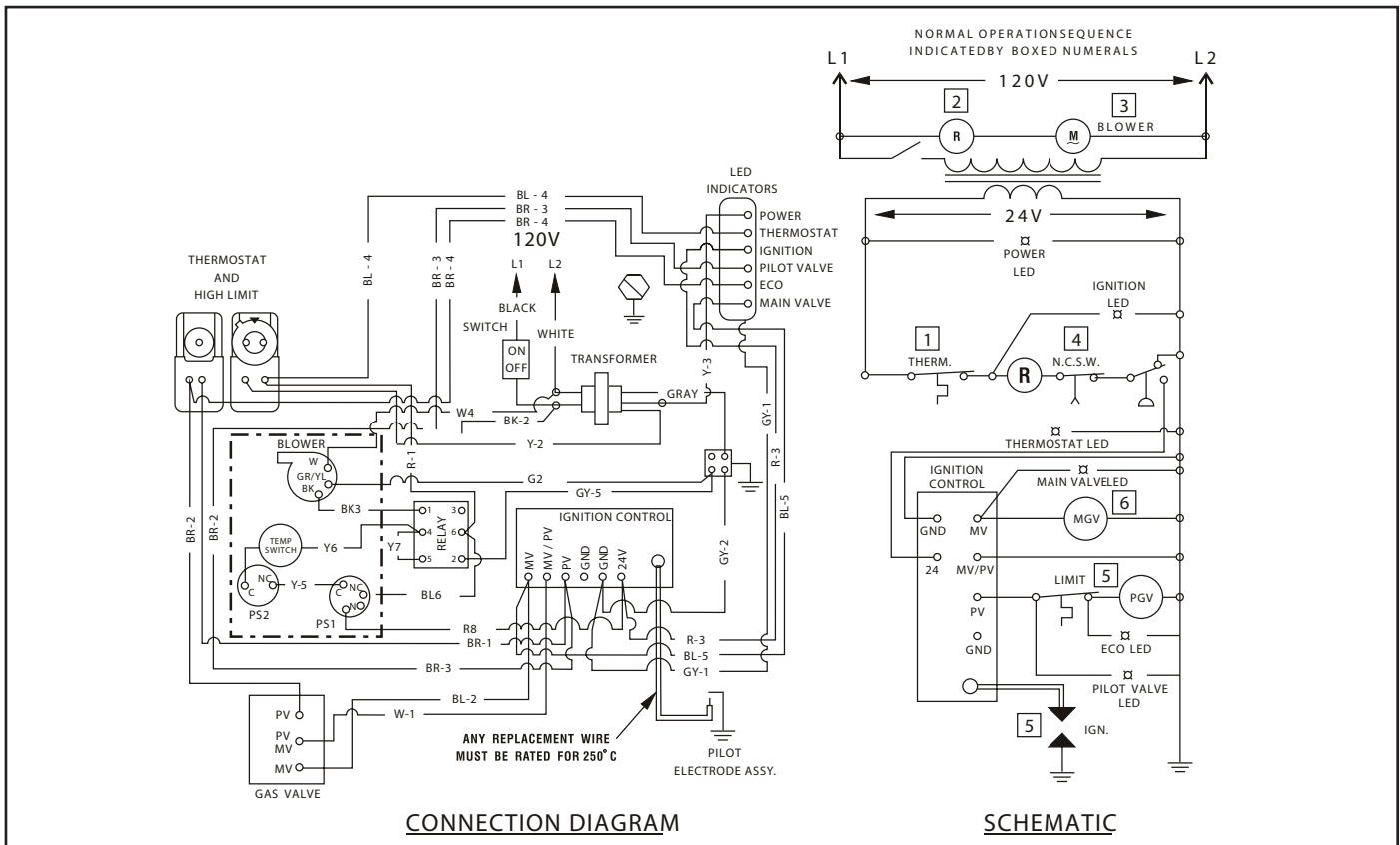
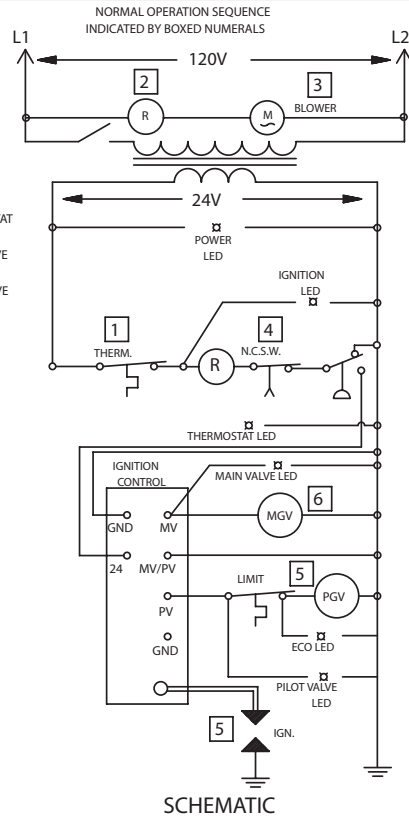
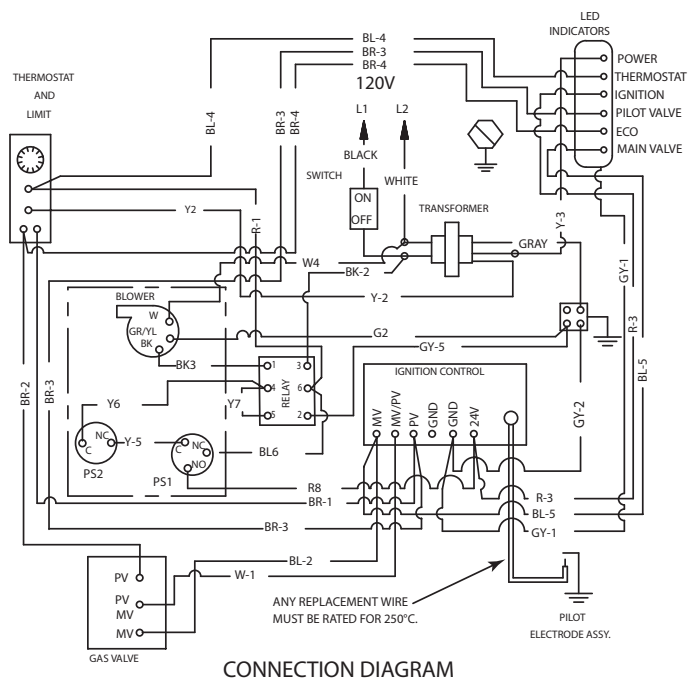

Figure 14. — Diagrams for units supplied with Honeywell VR8304P or VR8304M Gas Valve and Honeywell S8600M Ignition Control, White-Rodgers Thermostat and Temperature Limiting Switch for vent pipe..

Wiring and Schematic Diagrams

NOTICE: If any of the original wire as supplied with this appliance must be replaced, it **MUST** be replaced with 18 GA., 600V, 105°C wire or its equivalent, unless otherwise noted.



CAUTION! Label all wires prior to disconnection when servicing controls. Wiring errors can cause improper and dangerous operation. **VERIFY PROPER OPERATION AFTER SERVICING!**

Figure 14. — Diagrams for units supplied with Honeywell VR8304P or VR8304M Gas Valve and Honeywell S8600M Ignition Control.

How to Obtain Service Assistance

1. Should you have any questions about your new water heater, or if it requires adjustment, repair, or routine maintenance, it is suggested that you first contact your installer, plumbing contractor or previously agreed upon service agency. In the event that the firm has moved, or is unavailable, refer to the telephone directory commercial listings or local utility for qualified service assistance.
2. Should your problem not be solved to your complete satisfaction, you should then contact the Manufacturer's National Service Department at one of the following address:

In The U.S.A.:

Rheem Manufacturing Co., Water Heater Division
800 Interstate Park Drive
Montgomery, Alabama 36109
Phone: 1-800-432-8373.

In CANADA:

Rheem Canada, Ltd. / Ltée
P.O. Box 2846
Hamilton, ON L8N 3P3
Phone: 1-800-268-6966.

When contacting the manufacturer, the following information should

The following Gaskets are required for Normal Maintenance for all Models:

[SP5886](#) Tank Handhole Sealplate Gasket

All other Parts can be ordered by providing the following information:

1. Description of Part(s), such as:
 - Main Gas Valve
 - Pilot Burner
 - Main Burner
 - Thermostat
 - Blower Assembly
 - Anode Rod
 - Or other parts as required.
2. Quantity of each part required.
3. Complete models number and name of the water heater.
4. Serial Number of water heater.
5. Specify Type of Gas.
6. Address Parts Orders to your distributor or dealer.

be made available:

- a. Model and serial numbers of the water heater as shown on the rating plate attached to the jacket of the heater.
- b. Address where water heater is located and can be seen.
- c. Name and address of installer and any service agency who performed service on the water heater.
- d. Date of original installation and dates any service work was performed.
- e. Details of the problem as you can best describe them.
- f. List of people, with dates, who have been contacted regarding your problem.