



ELECTRIC ROTISSERIE

« OLYMPIA GRANDES FLAMMES RANGE »

**Ref.: 1375.60xE 975.60xE
 1375.40xE 975.40xE
 975.20xE**

INSTRUCTIONS FOR : INSTALLATION USE MAINTENANCE



Membre de la Chaîne des Rôtisseurs

1450 W 228th Street, Unit 10, TORRANCE, CA 90501 USA.- E-mail : info@rotisolusa.com
FRANCE Tél.: (331) 6421 8019 - Fax : (331) 6426 1685 - E-mail : export@rotisol.com

1. PRESENTATION DE L'APPAREIL

1.1. GENERALITES

Rotisserie range " MASTERFLAME ELECTRICAL" functioning with electricity with a power of 208/ 230V ~ 60 Hz three phases + earth.

Reference	Lenght (inch)	depth (inch)	Height (inch)	weight (Lbs)	Capacity	Electrical power (kw)
1375.6OxE	53 3/4	28	78 3/8	783	30/36	37
1375.4OxE	53 3/4	28	53 5/8	419	20/24	25,8
9756.OxE	38	28	78 3/8	640	12/18	26,5
9754.OxE	38	28	53 3/4	386	8/12	18,5
9752.OxE	38	28	38 5/8	275	4/6	10,4

The device is for professional use and should be used by qualified personnel.

Before starting any operation, please see these instructions. Carefully keep available near the rotisserie.

The upgrading of premises are at users expense.

Every cooking appliance generates heat and particles of fat.

The unit should be installed in accordance within norm's and regulations in force in a well-ventilated area. With sufficient mechanical extraction and fire prevention. Would recommend that you call upon a qualified company for the work to be done according to the local norm's extraction, gas connection, building work.

We recommend that you call upon a qualified installer for the connection of the unit to the electrical supplies.

Interventions on the electrical parts must be performed by qualified personnel accordance with the standards.

The company is not liable for damages if:

- improper use of the device
- non-compliance with standards
- incorrect installation
- non compliance with guidance on maintenance
- unauthorized modification
- installation of non-original spare parts
- installation and use of the rotisserie different than those provided by the manufacturer

The plate is located at the bottom left of the unit..

1.2. DESCRIPTION OF THE DEVICE

Ref: 1375.60E

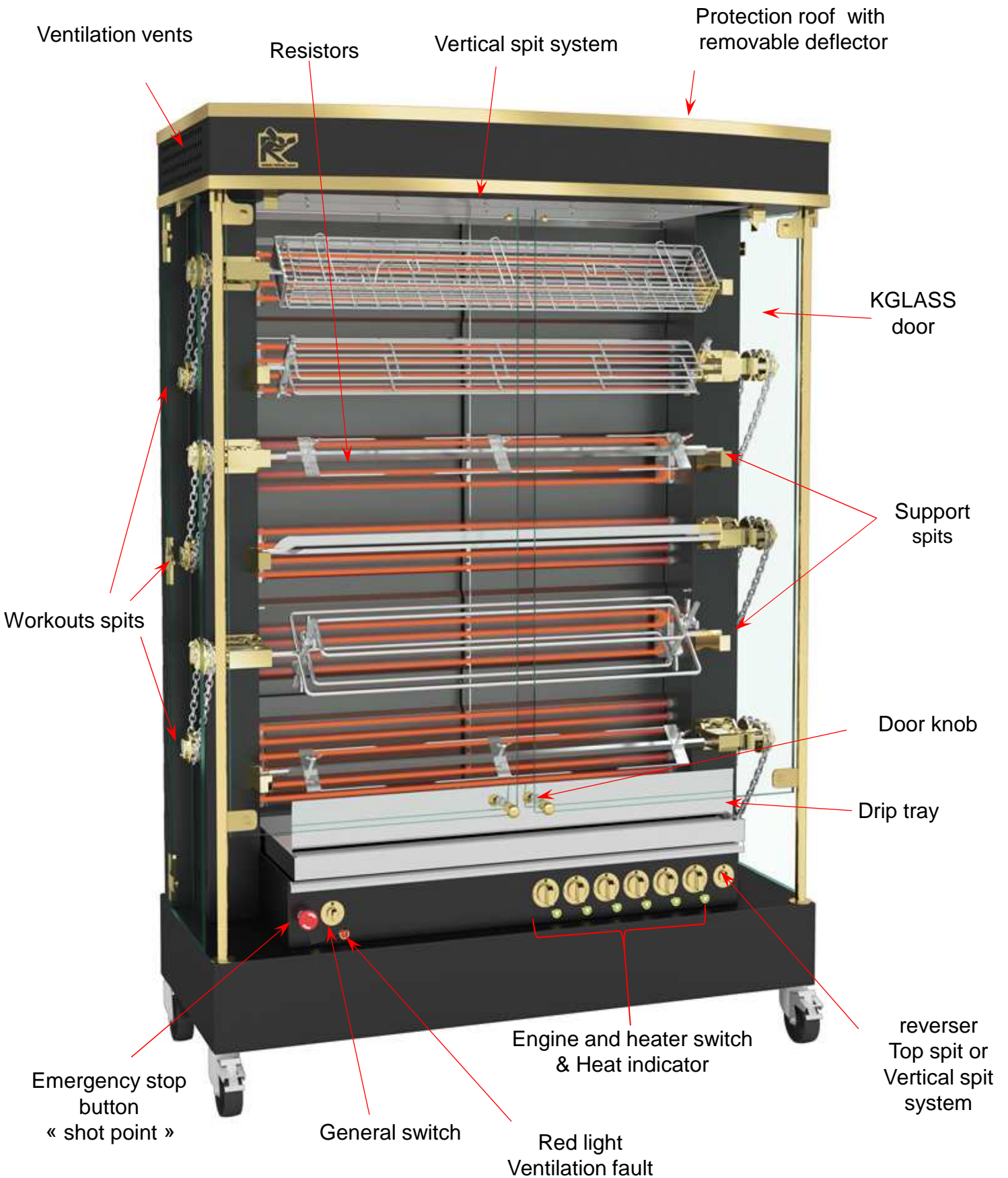

1.3. DESIGN

- Black enamel + brass or stainless steel fittings for luxury version.
- Stainless steel + brass or stainless steel fittings for luxury stainless steel version.
- Luxury version Email black + brass or stainless steel fittings.
- 6 or 4 pins that can be used in 2 different positions with chains and pulleys.
- 1 integrated string system.
- 1 individual motor ventilated for each spit and for the vertical spit system.
- 1 red safety light for the operation of motor fans.
- Shielded resistors
- Removable parables for cleaning.
- Electrical safety by emergency button "punch".
- Protective glass K.GLASS (against heat) with locking on opening and closing.
- Interior lighting with halogen lamps.
- Juice trays equipped with a drain plug.
- Protective roof with ventilation openings.
- Deflector with removable louvers on the upper part for fat removal.
- Base with 4 swivel castors including 2 with brakes for 6-spit models.

1.4. ACCESSORIES – OPTIONS

- Specific color Enamel.
- Storage or heating basements with doors or drawers for 4 or 2-spit models
- Various spits (spit cuissanpics, poultry spit, etc ...).
- Dropout spits.
- Raised rack for storing meat in juice tray.

1.5. BASE CABINET - OPTIONS

- Basements storage or heating equipped with a removable shelf and a shelf.
- Basements heating equipped with a storage shelf and storage drawers for poultry on spits.
- Undercarriage with heated drawers with independent thermostatic regulation and hygrometry.
- Undercarriage special storage racking.
- Base with 4 swivel castors including 2 with brakes

2. INSTALLATION

Before connecting and starting the rotisserie, please make sure that the electrical reservations are made. This work remains the responsibility of the user, who must have them executed, by approved companies, near the location of the rotisserie.

2.1. SETTING UP

Move the rotisserie by qualified personnel to using a lift of sufficient power in relation to the weight. Unpack the furniture which is circled, filmed and fixed on a pallet. Dispose of packaging according to local regulations.

2.2. ELECTRICAL CONNECTION

Power supply: 208/ 230V ~ 60 Hz three phases + earth.

Check that the mains voltage corresponds to the electrical characteristics indicated on the nameplate.

In any case, connect the earth electrode. Do not put the power cable in the waypoints.

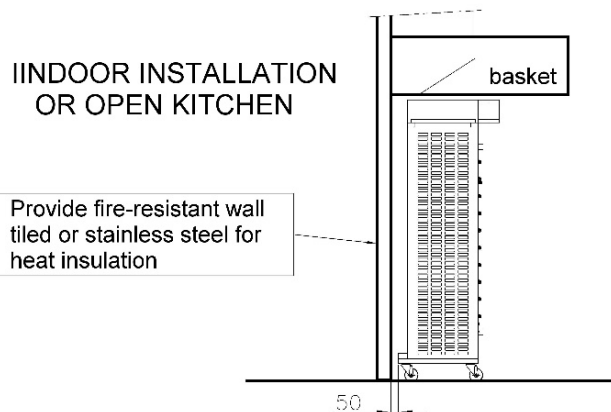

2.3. INSTALLATION OF A BACKGROUND PARABLE

Upon delivery, you must mount the parables as follows, starting with **the bottom one**.

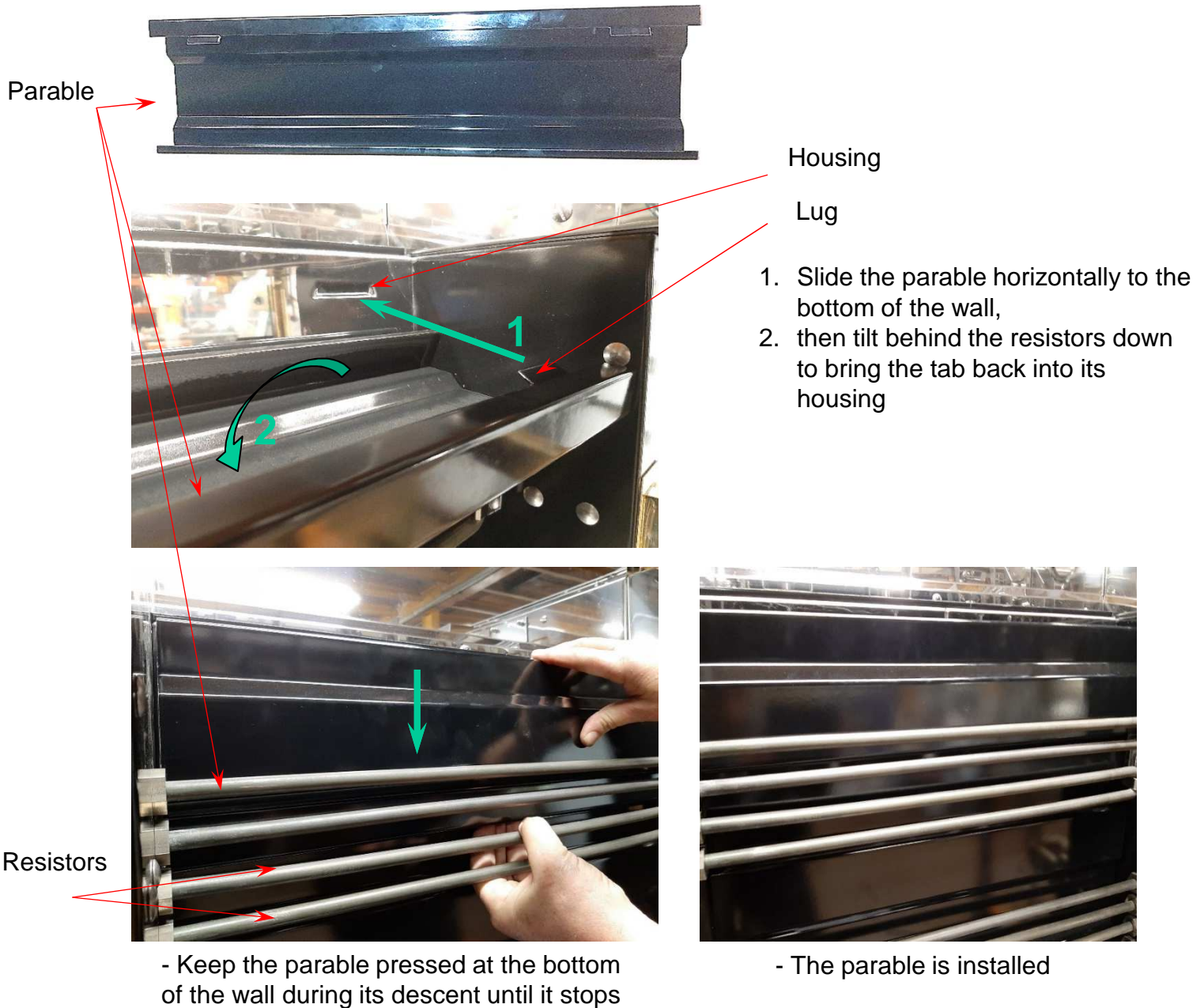

Proceed in the same way for the other parables.

2.4. INSTALLATION OF THE VENTILATION HATCH

Upon delivery, you must mount the ventilation hatch.

- On top of the rotisserie, slide the hatch in the two guides to the bottom of the stopper.



3. COMMISSIONING – USE

3.1. RECOMMENDATIONS FOR USE

- The appliance must not be installed close to steam, grease (deep fat fryer, ...), splashing water, high temperature or any other harmful condition.
- The rotisserie must be used by qualified personnel.
 - **Put water in the juice container about 5/8”.. There must always be water in the tank.**
- In the case of using an intermediate juice tray, it is also imperative to put water in this one, about 1.5 cm. Similarly, there must always be water in the tank.
- In order to prevent greasy splashes and for the proper functioning of the appliance, the doors must be closed.
- Light your resistors 15 minutes before cooking.
- It is recommended to wear gloves, an apron and a cap for the use of the rotisserie
- By opening the doors the rotation of the spits stops which allows to put and remove the spits.
- Skewer your chickens and position the spits inside the rotisserie:
first introduce the hex end of the spindle into the side drive bracket chain, then place the cylindrical end of the spit on the opposite support.
- The red light indicates that the engines are no longer ventilated, contact your dealer.

3.1.1. OPERATING INSTRUCTIONS

1. Check the power connection of the rotisserie to the mains.
2. Check if the machine is turned on, white light is on.
3. Set the main switch to the "o" position (ventilation & lighting)
The red light comes on for a few seconds
4. To rotate a spit, set the corresponding switch to the "o" position.
5. Switch on the heating elements with reduced power: position "oo".
6. Switch on all heating resistances total power: "ooo" position.
7. Stop the general, set the main switch to the "□" position.

3.1.2. OPERATION

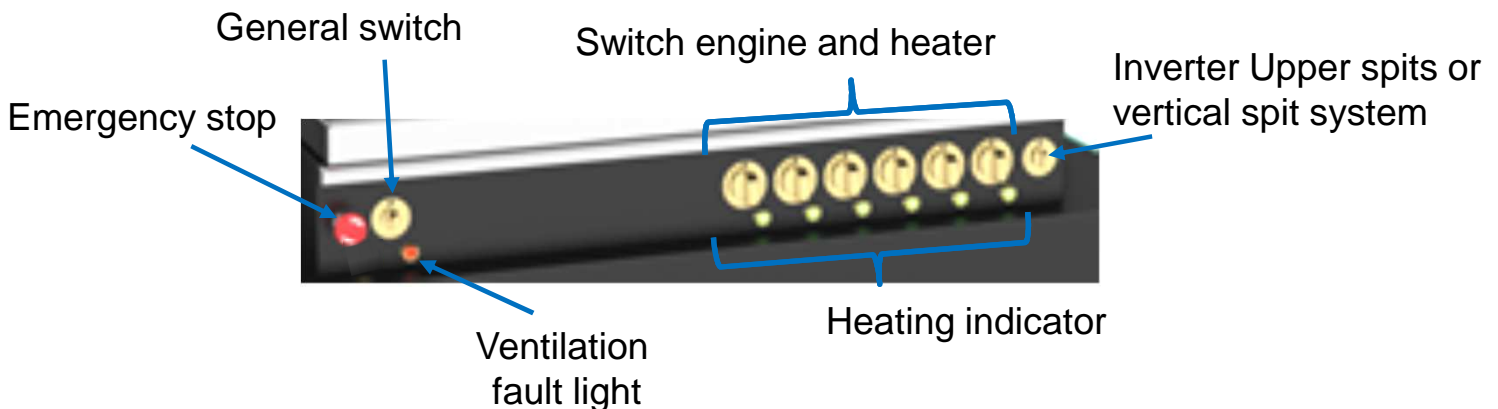

3.1.2. GENERAL SWITCH :

Make sure the emergency stop is not engaged,

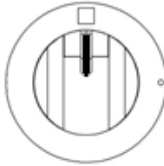
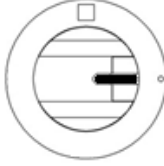

(Turn to the right)

POSITION 0	POSITION 1
	
General Stop	Lighting & General Power

3.1.3. ROTATION & HEATING: 1 switch per spit
 1375.6OE & 975.6OE : 6 switches
 1375.4OE & 975.4OE : 4 switches

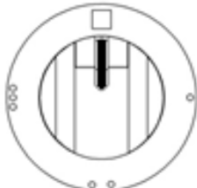
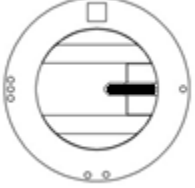
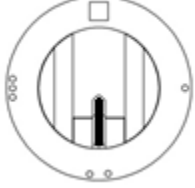
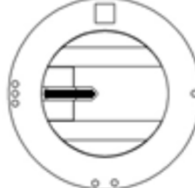
POSITION 0	POSITION 1	POSITION 2	POSITION 3
			
Engine stop and heater	•Rotation of the spit	Rotation & Reduced power	Rotation & Total Power

3.1.4. VERTICAL SPIT SYSTEM

Warm up the upper level
 (the penultimate floor can also be warmed up)
 Turn the switch to position 2
 The rotation of the motors of the upper spit as well as the last but one stop.

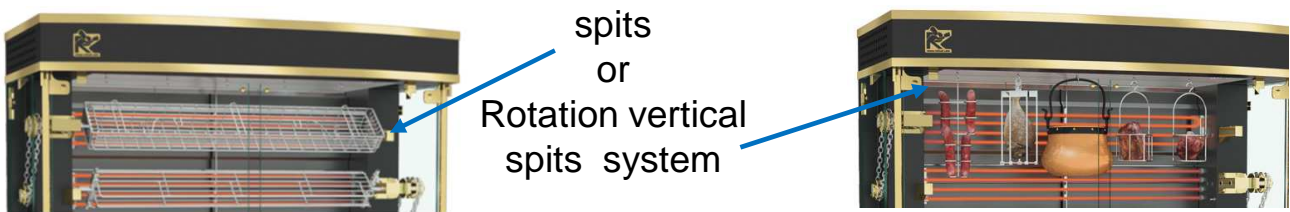

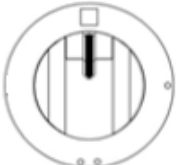
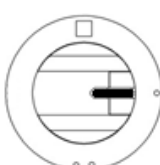
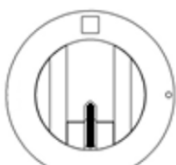
POSITION 0	POSITION 1	POSITION 2
		
Upper spits & Vertical spit system	Vertical spit system	Upper spits

3.1.5. LIGHTING

The lighting is controlled by the general switch.

Replacement halogen lamp

Cut off the power

Loosen the screw holding the access hatch on top of the rotisserie

Remove the old lamp and replace the new one without touching it

Replace the hatch and the screw

Reconnect the rotisserie

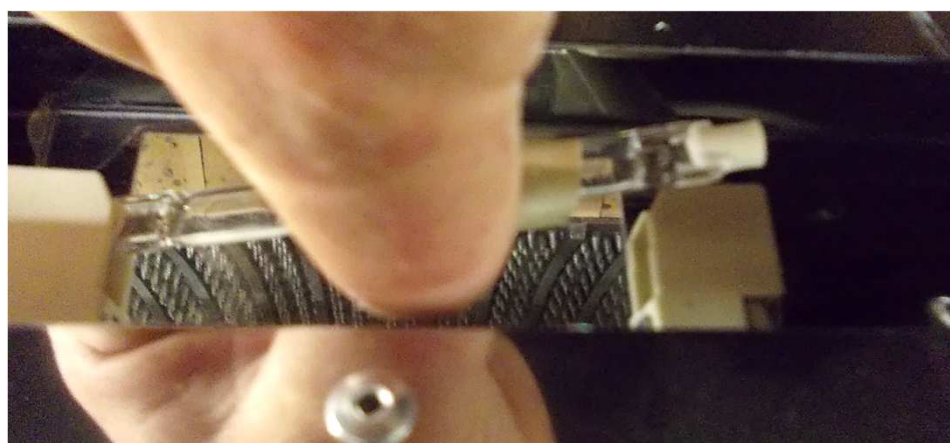
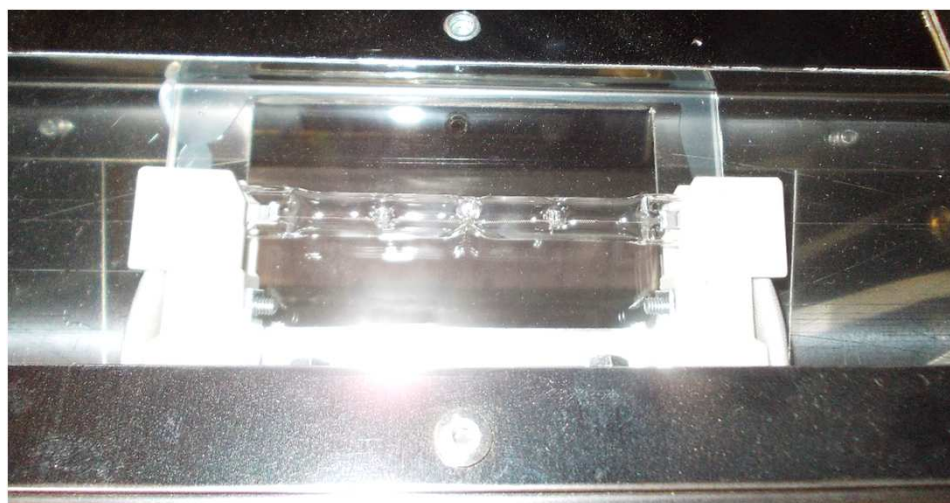

3.2. RECOMMENDATIONS

3.2.1. WHAT HAS TO BE DONE

Always put water in the juice tray, about 5/8".

Use heat-resistant gloves to skewer and unplug.

Clean windows, baffles and interior panels daily with a non-abrasive detergent.

Ice creams are expensive, do not forget to insure them (they are not guaranteed).

Unplug the rotisserie before any intervention.

3.2.2. WHAT YOU SHOULD NOT DO

Never use the juice tray with resistances in operation below. The temperature would be too high and the grease could catch fire. Locating it below the first resistance heats it at a sufficient distance.

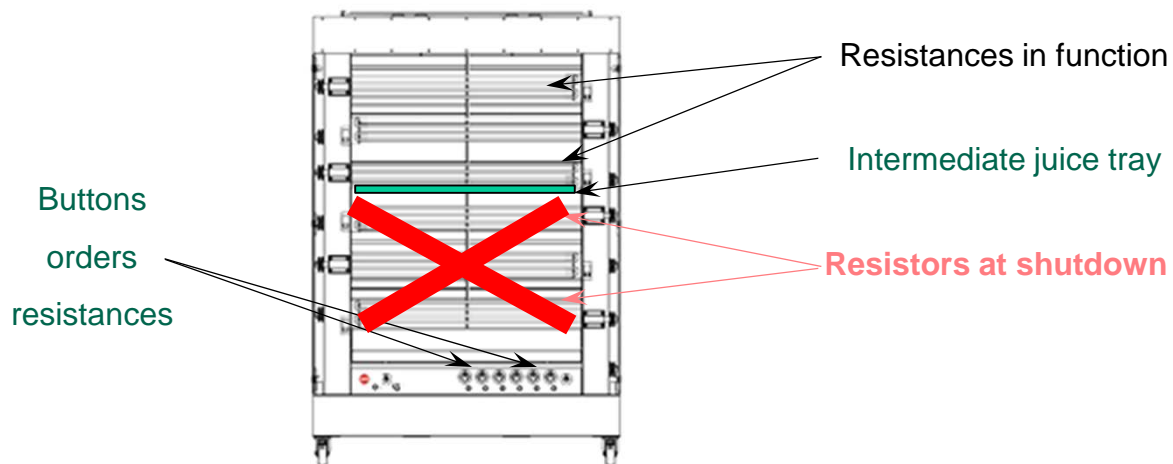

- Never leave fat spill tray juice. Empty it regularly. Grease could catch on fire
- Do not touch the "HALOGENES" lamps with your fingers.
- Do not cover the gill plate (on the top of the rotisserie).

3.3. COOKING TIPS

The cooking time varies depending on the size of your poultry between 45 and 60 minutes.

You can, after cooking, let your spits turn, as long as you turn off the resistors.

4. CLEANING – MAINTENANCE

4.1. DAILY

- It is very important that your rotisserie is cleaned after each use. Soak spits, spit spikes and juice tray for easier cleaning.
- Exterior enamelled panels should be cleaned with a non-abrasive detergent (see MEGACLEAN SPITS),

4.2. EVERY MONTH

Apply MEGACLEAN OVEN to the right side motor spits drive in your rotisserie. Rotate for 15 to 20 minutes and rinse with clean water.

**FOR BETTER SERVICE, WE RECOMMEND AN INTERVIEW
PERIODIC TO BE CARRIED OUT BY A QUALIFIED INSTALLER.**

4.3. EVERY 6 MONTHS

Check and check the cleanliness of the whole.

5. CHECKING OF THE GOODS

The product travels at the risk of the buyer. He should check the good condition.

On receiving the goods, one should proceed as follows:

- **Check in the presence of the carrier**, and quantity of the goods. If there are any abnormalities call your insurance company to make a claim or make a claim directly with the transport company.
- If the carrier does not remain present for this control, focus on the delivery order
- "REFUSAL TO ATTEND THE CARRIER UNPACKING" and prevent those responsible for the shipping company.
- Reservations must be confirmed to the carrier within three days, by registered letter with return receipt requested, with copies to Rotisol.
- Failure to follow this procedure relieves the carrier's liability and the expense of the recipient Rotisol.

6. GARANTEE

Rotisol guarantee for a period of 12 months from the invoice date to the specification by Rotisol manufacturing.

In case of manufacturing defect, the procedure for exchange or repair of products recognized as defective.

The exchange of parts under warranty requires the buyer to provide a copy of the original invoice of the goods.

The cost and risks of transportation, the cost of dismantling, reassembling, spare parts and repair costs on site (staff, accommodation and equipment) are the responsibility of the buyer.

The warranty does not cover defects that come from the non-compliance of the installation, the product (improper installation, connection error, overvoltage, lightning, ect...), and incorrectly used modification or intervention by the purchaser or a third party.

Are excluded from the benefit of the guarantee the following items: mirrors, glass, quartz halogen lamps, granite, light bulbs, gaskets. We advise our clients to take out insurance « broken windows ».

To obtain warranty, all defective parts must be returned to 8 days. The parts under warranty are sent out at costs to the customer and are reimbursed upon receipt of defective parts, after inspection in our workshops.

Products replaced under warranty are guaranteed themselves for the remaining term to run under the original warranty.

Past 12 month warranty, all new parts replaced or shipped, pay the postage or labor force and displacement and **will be guaranteed three months from the date of invoice.**

In case of dispute the customer will be required to provide the original invoice, the absence of this document will void the warranty.

Any technical assistance from Rotisol will be bill to the customer.

7. ELECTRIC DIAGRAMS

8. SPARE PARTS

8.1. EXPLODED ROTISSERIE 1375.6OE

8.2. NOMENCLATURE SPARE PARTS ROTISSERIE 1375.6OE

Electrical diagram of the Rotisserie "OLYMPIA" range Ref.: 1375.20E – 975.20E Electrical



N° SE1375.2.0E-975.2.0E

Switching phases

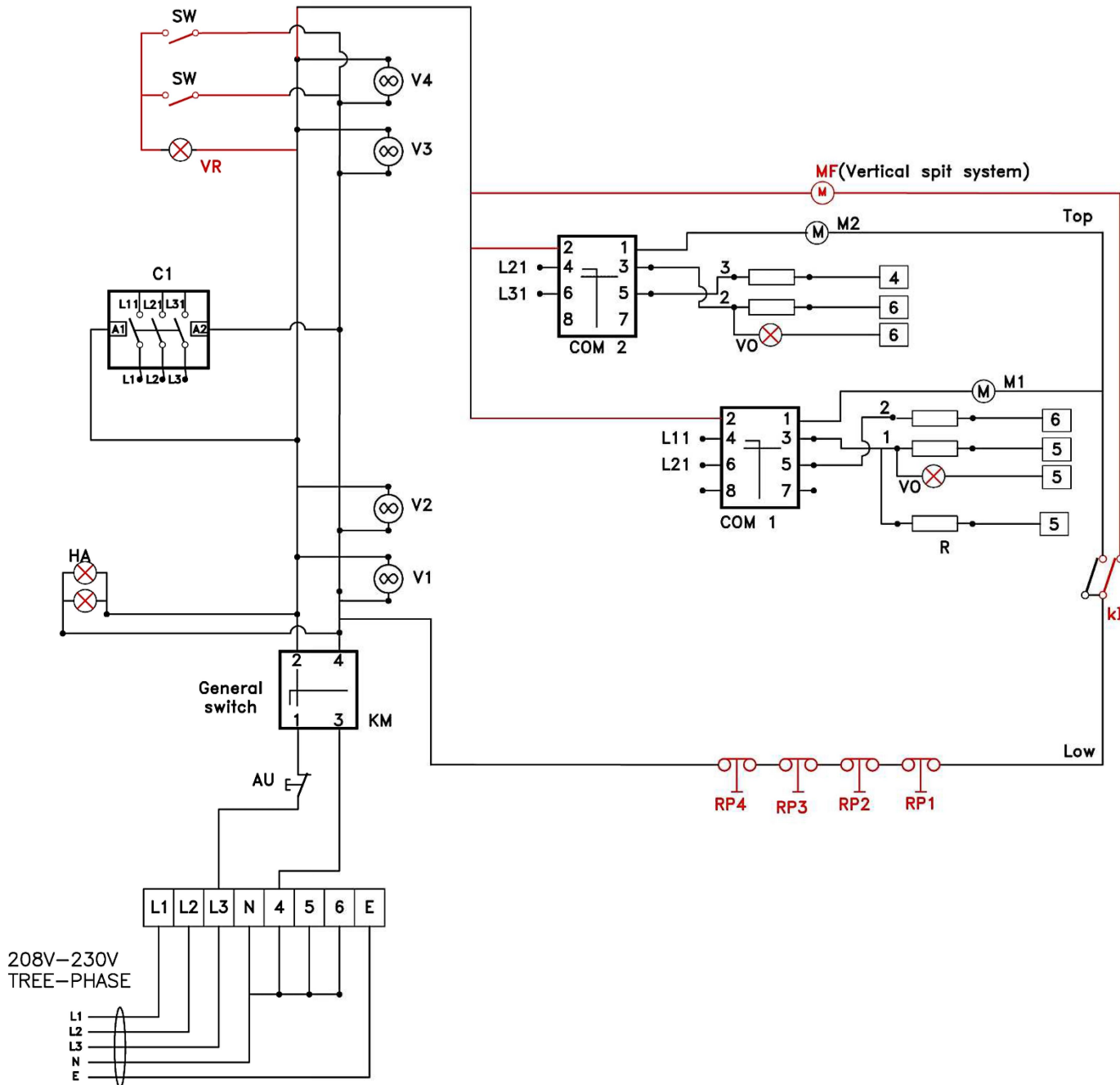
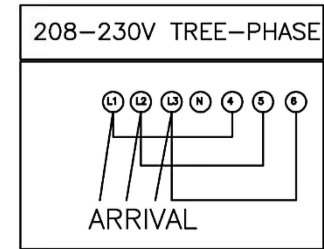

	975.20E	1375.20E
HA – Halogen Ref: LA150119	1x150W	2x150W
R – Resistors	5x 2000W RESI61055	5x2800W RESI61054
Power :	10,4kW	14,6kW

COM – 2 Switches power 4 positions (Ref: CH10-4F-A033)

C – 1 Switch Ref.: CONGMS

M – 2 Motors Olymp + 1 standard motor (MF)

AU – 1 emergency stop Ref.: TETAR

VO – 2 Heat indicators

KM – 1 switch 2 positions for
the main power supply, motors and lighting

RP – 4 Door disconnect switch

KI – reverser

SW – Fan safety switch

VR – faulty ventilation indicator

V – 4 fans

Electrical diagram of the Rotisserie "OLYMPIA" range Ref.: 1375.40E – 975.40E Electrical



N° SE1375.4.0E-975.4.0E

Switching phases

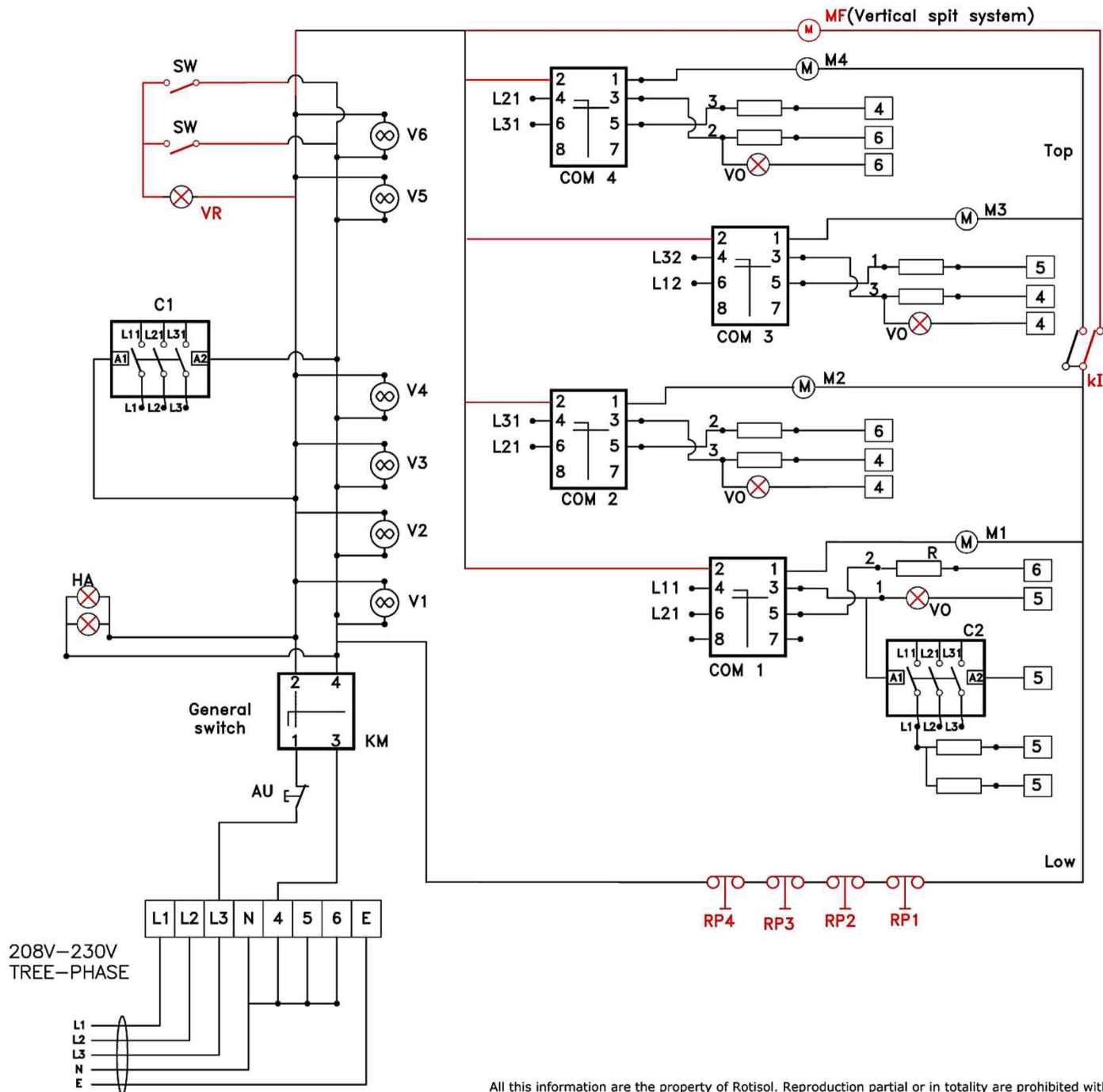
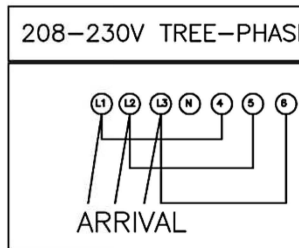

	975.40E	1375.40E
HA - Halogen Ref: LA150119	1x150W	2x150W
R - Resistors	9x 2000W RESI61055	9x2800W RESI61054
Power :	18,5kW	25,8kW

- COM - 4 Switches power 4 positions (Ref: CH10-4F-A033)
- C - 1 Switch Ref.: CONGMS
- C2 - 1 Switch Ref.: CONGMS for 1375.40E
- M - 4 Motors Olymp + 1 standard motor (MF)
- AU - 1 emergency stop Ref.: TETAR
- VO - 4 Heat indicators
- KM - 1 switch 2 positions for the main power supply, motors and lighting
- RP - 4 Door disconnect switch
- kI - reverser
- SW - Fan safety switch
- VR - faulty ventilation indicator
- V - 6 fans

Electrical diagram of the Rotisserie "OLYMPIA" range Ref.: 1375.60E – 975.60E Electrical



N° SE1375.6.0E-975.6.0E

Switching phases

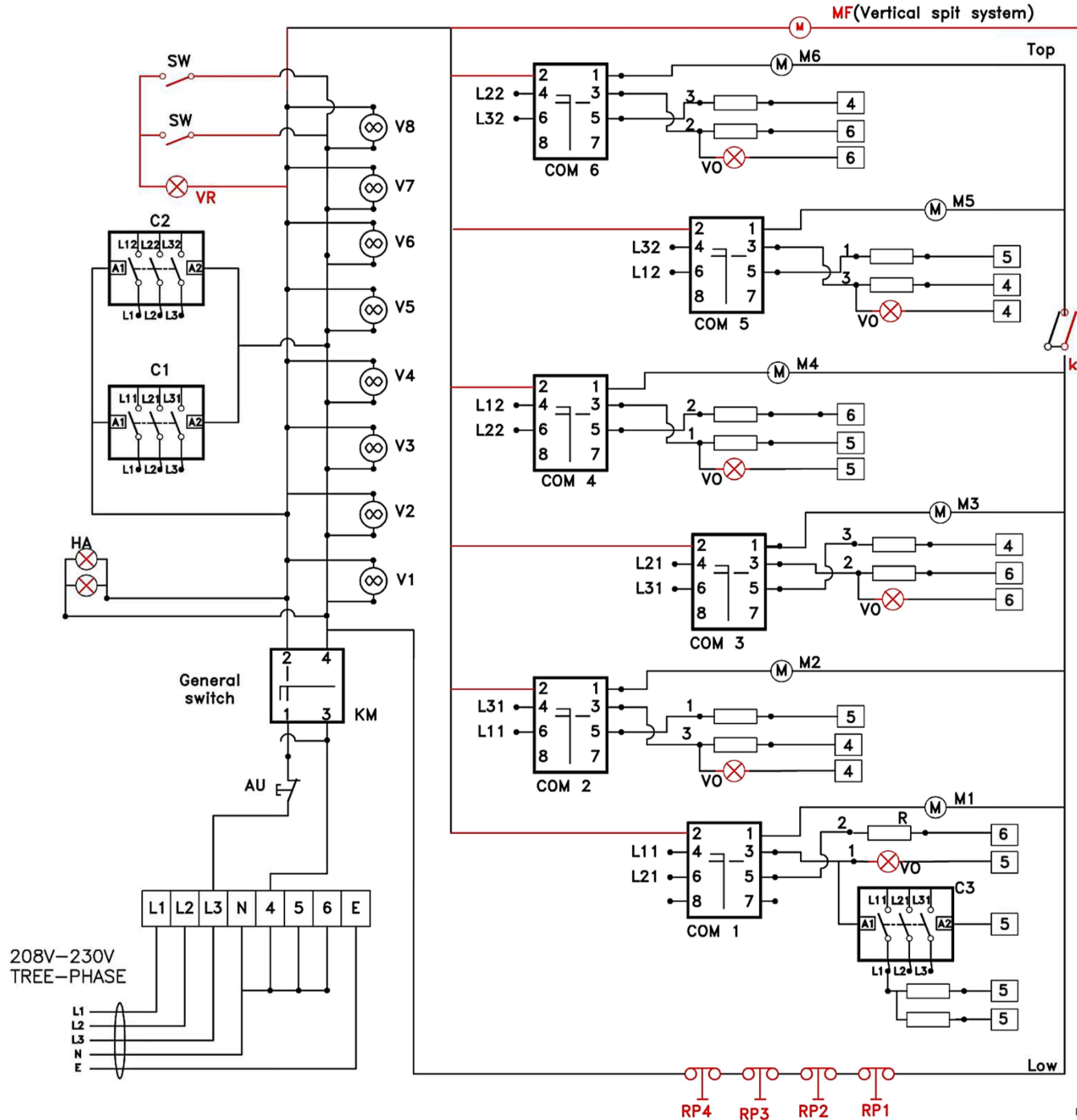
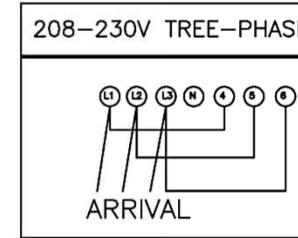

975.60E | 1375.60E

HA - Halogen
Ref: LA150119

1x150W

2x150W

R - Resistors

13x2000W
RESI61055

13x2800W
RESI61054

Power :

26,5kW

37kW

COM - 6 Switches power 4 positions (Ref: CH10-4F-A033)

C1 ; C2 - 2 Switches Ref.: CONGMS

C3 - 1 Switch Ref.: CONGMS for 1375.60E

M - 6 Motors Olymp + 1 standard motor (MF)

AU - 1 emergency stop Ref.: TETAR

VO - 6 Heat indicators

KM - 2 switches à 2 positions for
the main power supply, motors and lighting

RP - 4 Door disconnect switch

KI - reverser

SW - Fan safety switch

VR - faulty ventilation indicator

V - 8 fans

COOKING TIME

Products	Cooking time	Temperature. in °F
CHICKEN 1,3KG 1,5KG	1H	423°F
Spareribs 250G cooked	30 mn	423°F
Mice lamb cooked	30 mn	423°F
Knuckle's 600G cooked	45 mn	423°F
Jarretton cooked	45 mn	423°F
Roast pork cooked	45 mn	423°F
Cooked pork	45 mn	423°F
Spareribs cooked	45 mn	423°F
Brisket cooked	1H	423°F
Boiled knuckle	45 mn	423°F
Ham cooked on a spit	45 mn	423°F
Preheating	15 mn	423°F

All this information are the property of Rotisol.

Reproduction partial or in totality are prohibited without authority prior written of company Rotisol.