

MANUFACTURING

NUMBERS:

9210212

9210223

roundup

by A.J. Antunes & Co. ®

VERTICAL CONTACT TOASTER

Model VCT-2000 (Wide Mouth)



P/N 1010875 Rev. D 10/15



Owner's Manual

TABLE OF CONTENTS

Owner Information	2	Temperature Adjustments.....	8
Warranty Information	2	Temperature control panel.....	9
Service/Technical Assistance	3	Hi-Limit Reset Button	10
Important Safety Information	3	Fault Codes	11
Specifications	5	Maintenance	12
Electrical Ratings.....	5	Daily.....	12
Electrical Cord & Plug Configuration.....	5	Replacing Black and Silver Release Sheet (Every 4 to 6 weeks).....	13
Dimensions.....	5	Replacing Belt Wraps (Every 3 to 6 months).....	13
Installation	6	Conveyor Belt Chains (Every 3 to 6 months).....	14
Unpacking.....	6	Adjusting conveyor belt Chains.....	14
Equipment Setup.....	6	Roller Tensioners (Every 3 to 6 months).....	15
Assembling the Unit	6	Troubleshooting	16
Operation	8	Replacement Parts	20
Operating Instructions	8	Wiring Diagram	25
		Limited Warranty	28

OWNER INFORMATION

General

The Vertical Contact Toaster Model VCT-2000 is designed for contact toasting of buns. The toaster design allows the operator to place buns on both sides of the heated platen at the same time. Buns are placed into the top of the toaster and uniform, golden brown, warm buns are then retrieved at the base of the toaster.

This manual provides the safety, installation, and operating procedures for the Vertical Contact Toaster Model VCT-2000. We recommend that all information contained in this manual be read prior to installing and operating the unit.

Your Vertical Contact Toaster Model VCT-2000 is manufactured from the finest materials available and is assembled to Roundup's strict quality standards. This unit has been tested at the factory to ensure dependable trouble-free operation.

Warranty Information

Please read the full text of the Limited Warranty in this manual.

If the unit arrives damaged, contact the carrier immediately and file a damage claim with them. Save all packing materials when filing a claim. Freight damage claims are the responsibility of the purchaser and are NOT covered under warranty.

The warranty does NOT extend to:

- Damages caused in shipment or damage as result of improper use.
- Installation of electrical service.
- Normal maintenance as outlined in this manual.
- Malfunction resulting from improper maintenance.
- Damage caused by abuse or careless handling.
- Damage from moisture into electrical components.
- Damage from tampering with, removal of, or changing any preset control or safety device.

IMPORTANT! Keep these instructions for future reference. If the unit changes ownership, be sure this manual accompanies the equipment.

OWNER INFORMATION (continued)

Service/Technical Assistance

If you experience any problems with the installation or operation of your unit, contact your local Authorized Service Agency.

Fill in the information below and have it handy when calling your Authorized Service Agency for assistance. The serial number is on the specification plate located on the rear of the unit.

Purchased From: _____

Date of Purchase: _____

Model No.: _____

Serial No.: _____

Mfg. No.: _____

Refer to the service agency directory included with your unit.

Authorized Service Agency

Name: _____

Phone No.: _____

Address: _____

Use only genuine Roundup replacement parts in this unit. Use of replacement parts other than those supplied by the manufacturer will void the warranty. Your Authorized Service Agency has been factory trained and has a complete supply of parts for this toaster.

You may also contact the factory at **1-877-392-7854** (toll Free in the U.S.) or **630-784-1000** if you have trouble locating the nearest Authorized Service Agency.

IMPORTANT

A.J. Antunes & Co. reserves the right to change specifications and product design without notice. Such revisions do NOT entitle the buyer to corresponding changes, improvements, additions or replacements for previously purchased equipment.

IMPORTANT SAFETY INFORMATION

Throughout this manual, you will find the following safety words and symbols that signify important safety issues with regards to operating or maintaining the equipment.



WARNING

GENERAL WARNING. Indicates information important to the proper operation of the equipment. Failure to observe may result in damage to the equipment and/or severe bodily injury or death.



WARNING

ELECTRICAL WARNING. Indicates information relating to possible shock hazard. Failure to observe may result in damage to the equipment and/or severe bodily injury or death.



CAUTION

GENERAL CAUTION. Indicates information important to the proper operation of the equipment. Failure to observe may result in damage to the equipment.



WARNING

HOT SURFACE WARNING. Indicates information important to the handling of equipment and parts. Failure to observe caution could result in personal injury.

IMPORTANT SAFETY INFORMATION (continued)

In addition to the warnings and cautions in this manual, use the following guidelines for safe operation of the unit:

- Read all instructions before using equipment.
- For your safety, the equipment is furnished with a properly grounded cord connector. Do NOT attempt to defeat the grounded connector.
- Install or locate the equipment only for its intended use as described in this manual. Do NOT use corrosive chemicals in this equipment.
- Do NOT operate this equipment if it has a damaged cord or plug, if it is not working properly, or if it has been damaged or dropped.
- This equipment should be serviced by qualified personnel only. Contact the nearest Authorized Service Agency for adjustment or repair.
- Do NOT block or cover any openings on the unit.
- Do NOT immerse cord or plug in water.
- Keep cord away from heated surfaces.
- Do NOT allow cord to hang over edge of table or counter.

The following warnings and cautions appear throughout this manual and should be carefully observed.

- Turn the power off, unplug the power cord, and allow unit to cool down before performing any service or maintenance.
- The toaster should be grounded according to local electrical codes to prevent the possibility of electrical shock. It requires a grounded receptacle with separate electrical lines protected by fuses or a circuit breaker of the proper rating.

- Bread may burn. Therefore toasters must not be used near or below curtains or other combustible walls and materials. Failure to maintain safe operating distances may cause discoloration or combustion.
- When installing conveyor Belt Wrap, be careful not to wrap it over the upper and lower support rods or permanent damage to belt will occur. Make sure Belt Wrap is positioned UNDER the upper and lower support rods.
- Make sure both ends of Belt Wrap are aligned evenly before installing Belt Wrap Pin.
- Failure to use Release Sheets may result in damage to the equipment and loss of warranty coverage.
- Do NOT clean this appliance with a water jet.
- If supply cord is damaged, it must be replaced by the manufacturer or its service agent, or a similarly qualified person.
- All electrical connections must be in accordance with local electrical codes and any other applicable codes.
- **WARNING, ELECTRICAL SHOCK HAZARD. FAILURE TO FOLLOW THESE INSTRUCTIONS COULD RESULT IN SERIOUS INJURY OR DEATH.**
 - Electrical ground is required on this unit.
 - Do NOT modify the power supply cord plug. If it does not fit the outlet, have a proper outlet installed by a qualified electrician.
 - Do NOT use an extension cord with this appliance.
 - Check with a qualified electrician if you are unsure if the unit is properly grounded.

SPECIFICATIONS

Electrical Ratings

Model & Mfg. No.	Voltage	Watts	Amps	Hz.
VCT-2000 9210212 9210223	220 - 240	3019 - 3593	13.7 - 15	50

Electrical Cord & Plug Configuration

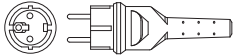
Model & Mfg. No.	Description	Configuration
VCT-2000 9210212 9210223	CEE 7/7, 16 Amp., 250 VAC	

⚠ WARNING ⚠

ELECTRICAL SHOCK HAZARD. FAILURE TO FOLLOW THE INSTRUCTIONS IN THIS MANUAL COULD RESULT IN SERIOUS INJURY OR DEATH.

- Electrical ground is required on this appliance.
- Do NOT modify the power supply cord plug. If it does not fit the outlet, have a proper outlet installed by a qualified electrician.
- Do NOT use an extension cord with this unit.
- Check with a qualified electrician if you are unsure if the appliance is properly grounded.

⚠ CAUTION ⚠

All electrical connections must be in accordance with local electrical codes and any other applicable codes.

Dimensions

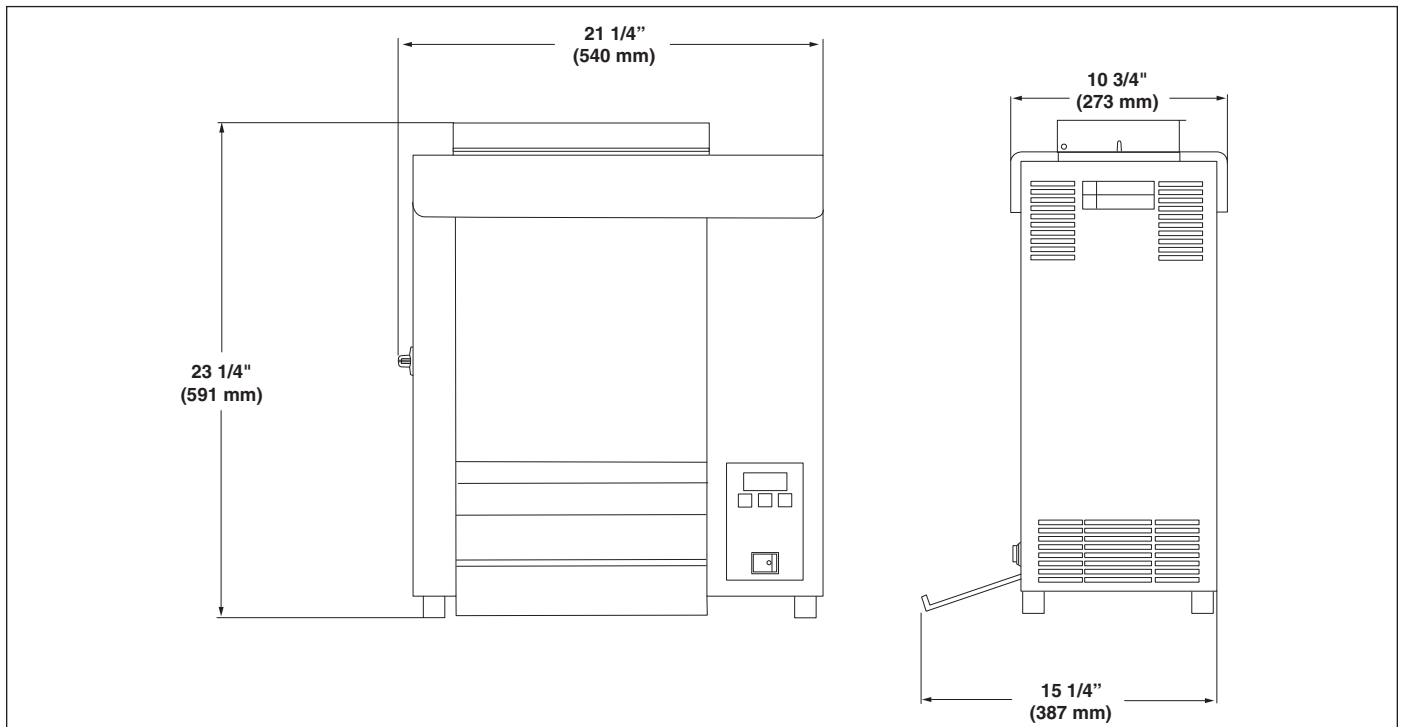

INSTALLATION

Unpacking

1. Remove the unit and all packing materials from shipping carton.
2. Open the included large box. It should contain the following:
 - Bun Chute (Figure 1).
 - Bun Feeder (Figure 1).
 - Two Release Sheets (Figure 1).
 - Owner's Manual.
 - Maintenance Card.
 - Authorized Service Agency Directory.
3. Remove all shipping tape and protective coverings from the unit and parts.

NOTE: If any parts are missing or damaged, contact Antunes Technical Service IMMEDIATELY at 1-877-392-7854 (toll free in the U.S.) or 630-784-1000.

Equipment Setup

Before placing the toaster into service, pay attention to the following guidelines:

- Make sure power to the unit is off and the toaster is at room temperature.
- Do NOT block or cover any openings on the unit.
- Do NOT immerse cord or plug in water.
- Keep cord away from heated surfaces.
- Do NOT allow cord to hang over edge of table or counter.
- Connect the unit to the proper power supply. Refer to the specification plate for the proper voltage.

Assembling the Unit

NOTE: The factory has pre-installed a Release Sheet over the Platen (Figure 1). Verify that it is properly in place before proceeding.

1. Remove Bun Chute and Bun Feeder from the box and install (Figure 1).

NOTE: Make sure Heat Shield Assembly is activating the Conveyor Safety Interlock Switch (Figure 1). The conveyors will not rotate unless the Heat Shield is in place and Conveyor Safety Interlock Switch is activated.

WARNING

Failure to use Release Sheets may result in damage to the unit and loss of warranty coverage.

CAUTION

Bread may burn. Therefore toasters must not be used near or below curtains or other combustible walls and materials. Failure to maintain safe operating distances may cause discoloration or combustion.

WARNING

ELECTRICAL SHOCK HAZARD. FAILURE TO FOLLOW THE INSTRUCTIONS IN THIS MANUAL COULD RESULT IN SERIOUS INJURY OR DEATH.

- Electrical ground is required on this appliance.
- Do NOT modify the power supply cord plug. If it does not fit the outlet, have a proper outlet installed by a qualified electrician.
- Do NOT use an extension cord with this unit.
- The toaster should be grounded according to local electrical codes to prevent the possibility of electrical shock. It requires a grounded receptacle with separate electrical lines protected by fuses or a circuit breaker of the proper rating.
- Check with a qualified electrician if you are unsure if the appliance is properly grounded.

CAUTION

All electrical connections must be in accordance with local electrical codes and any other applicable codes.

INSTALLATION (continued)

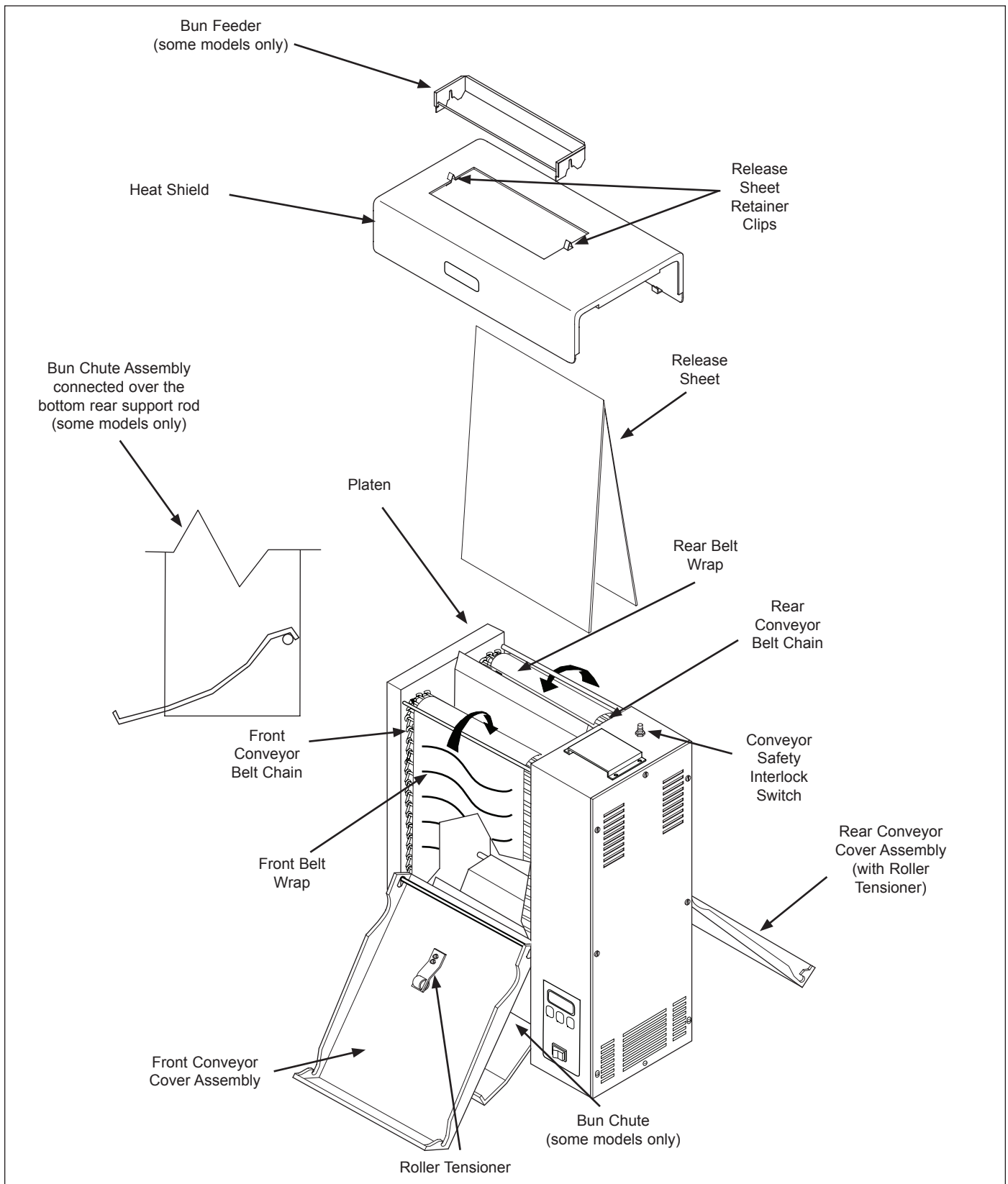

Figure 1. VCT-2000 Toaster

OPERATION

Operating Instructions

1. Set the Bun Thickness Adjustment Controls (Figure 3) to desired setting.

NOTE: Recommended settings are #2 for heel and #6 for crown.

2. Turn the Rocker Switch on. (Figure 2). Allow the toaster to warm up for 30 minutes.

NOTE: The temperature display (Figure 2) will flash “LO” until the toaster reaches its preset operating temperature. When the toaster approaches the pre-set temperature of 600°F (315°C), “USE” appears in the temperature display and the unit is ready to toast buns. If “USE” does not appear in the window after a warm-up period of approximately 30 minutes, contact your Authorized Service Agency.

3. Drop Crowns and Heels into the slot (Figure 2). Cut sides of heel and crown must face each other.
4. Toasted buns will drop into the bun landing area (Figure 2) in approximately 10 seconds.
5. Test at least four buns before putting the toaster into service.
6. Turn the Rocker Switch off when finished toasting for the day and proceed with the **Daily Cleaning** as outlined in the Maintenance section of this manual.

Temperature Adjustments

The VCT-2000 uses a Platen Heater and two Auxiliary Air Heaters. The Platen Heater consists of a heating element built into the Platen to toast the cut side of the bun. The two Auxiliary Heaters assist in providing additional heat to the buns. The first Auxiliary Air Heater is located between the conveyor in the front of the toaster. The second Auxiliary Heater is located between the conveyor at the rear of the unit.

RECOMMENDED TEMPERATURES

Recommended temperature setting for the Platen Heater is 600°F (315°C).

Recommended temperature setting for the Auxiliary Air Heaters is 400°F (204°C).

NOTE: The toaster is tested and shipped with the heaters set at the above recommended temperatures.

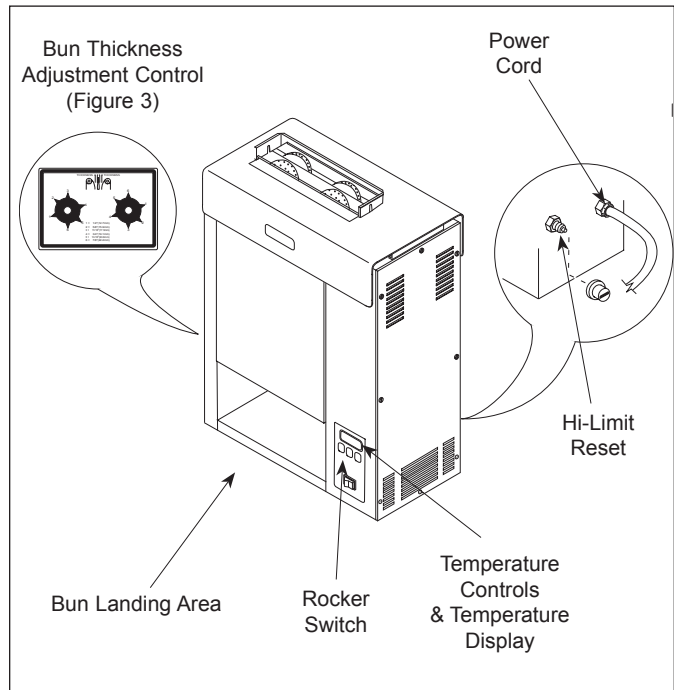

Figure 2. VCT-2000 Toaster

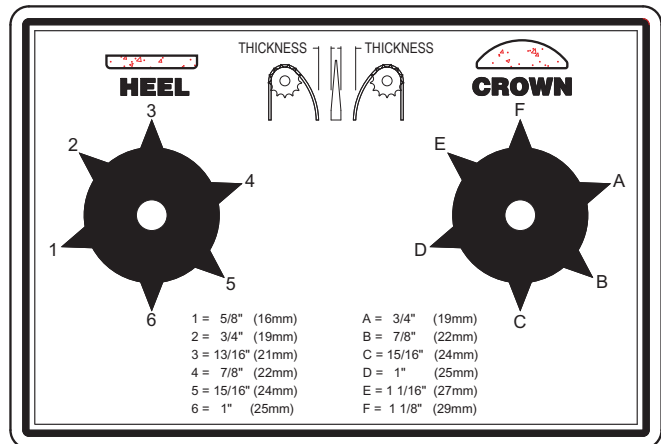

Figure 3. Bun Thickness Adjustment Controls

OPERATION (continued)

Temperature control panel

NOTE: The term “setpoint temperature” refers to the desired temperature setting.

To display the actual Platen temperature—providing it is over 440°F (227°C)—press the **TEMP UP** button.

To display the actual Auxiliary Air Heater temperature—providing it is over 360°F (182°C)—press the **TEMP DOWN** button.

To switch the temperature display between Fahrenheit (°F) and Celsius (°C), press and hold the **TEMP SCALE** button for 5 seconds.

PLATEN HEATER TEMPERATURE ADJUSTMENT

1. Turn the Rocker Switch on and wait for the Temperature Display to finish the power-up sequence (Figure 4).
2. Press and hold both **TEMP UP** and **TEMP DOWN** buttons for over 1 second until the display flashes the Platen setpoint temperature, then release (Figure 5).
3. Press the **TEMP UP** button to raise the setpoint temperature or press the **TEMP DOWN** button to lower the setpoint temperature.

NOTE: The Maximum Platen Setpoint Temperature is 600°F (315°C). If no change in temperature is made within 5 seconds, the display reverts back to the previous setpoint.

4. Release the button when the desired setpoint is displayed.

AUXILIARY AIR HEATER TEMPERATURE ADJUSTMENT

1. Turn the Rocker Switch on and wait for the Temperature Display to finish the power-up sequence (Figure 4).
2. Press and hold both **TEMP UP** and **TEMP SCALE** buttons for over 1 second until the display flashes the setpoint temperature, then release (Figure 6).
3. Press the **TEMP UP** button to raise the setpoint temperature or press the **TEMP DOWN** button to lower the setpoint temperature.

NOTE: The maximum Auxiliary Air Heater Setpoint Temperature is 400°F (204°C).

4. Release the button when the desired setpoint is displayed.

NOTE: If no change in temperature is made within 5 seconds, the display reverts back to the previous setpoint.

“Heat On” LED will blink on/off during warm-up and when either platen or auxiliary air heaters are calling for heat.

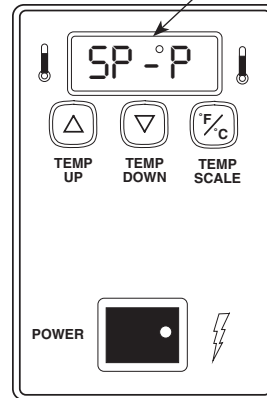

1. “SP-P” (Setpoint Platen) is displayed.

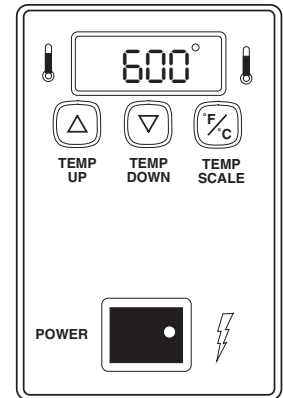

2. Current Platen Setpoint Temperature setting is shown.

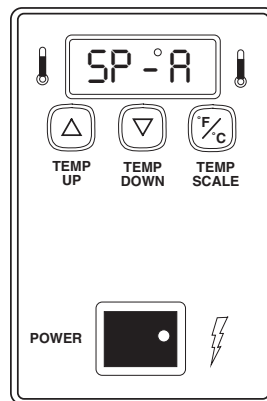

3. “SP-A” (Setpoint Auxiliary) is displayed.

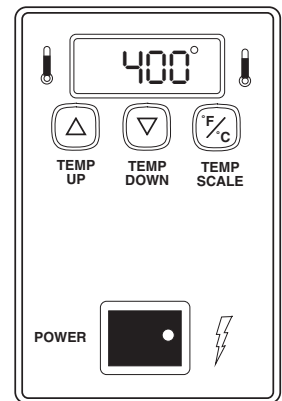

4. Current Auxiliary Air Setpoint Temperature is shown.

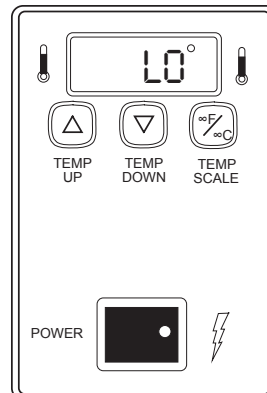

5. “LO” is displayed until platen temperature rises above 550°F (288°C).

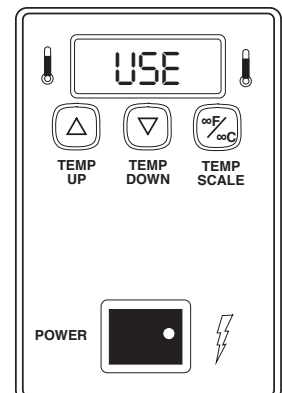

6. USE is displayed when Platen Setpoint Temperature* is reached

* Platen setpoint temperature must be between 460°F (238°C) and 600°F (315°C).

Figure 4. Temperature Power Up Sequence

OPERATION (continued)

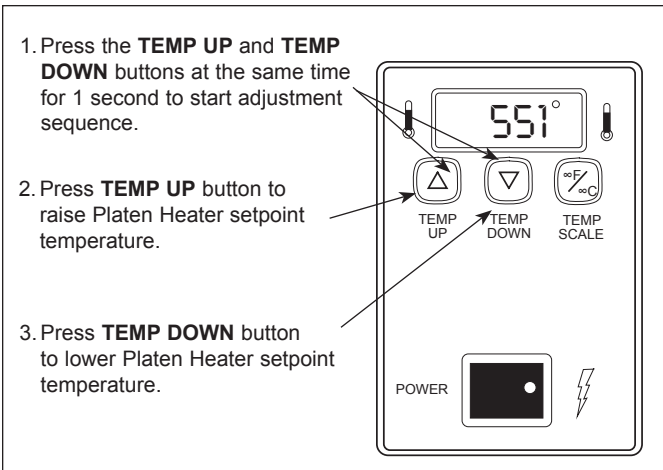

Figure 5. Platen Heater Setpoint Temperature

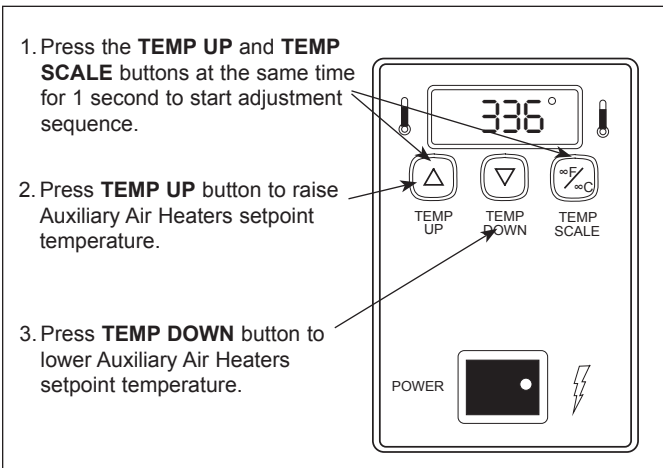

Figure 6. Auxiliary Air Heaters Setpoint Temperature

Hi-Limit Reset Button

A Hi-Limit Control turns off electrical power to the heater and control circuits if the Platen overheats. To reset the control, allow sufficient time (10-15 minutes) for the unit to cool, then locate the Reset Button at the rear of the unit. Remove the black protective cap, press the Reset Button, and reinstall the protective cap (Figure 2).

NOTE: If the unit requires continuous resetting, contact your Authorized Service Agency.

OPERATION (continued)

Fault Codes

	<p>If the toaster control board resembles the OLD style shown here, refer to the Fault Message in Table 1.</p>
FAULT CODE ON DISPLAY	FAULT CODE DESCRIPTION
"HI" Flashes on display	The platen thermocouple is disconnected or open or the platen relay is shorted. Call for service.
"HI" and "LO" flashes at cold start up	The auxiliary thermocouple is disconnected or open. Call for service.
"HI" and "USE" flashes after 30 minutes of pre-heat time	The auxiliary thermocouple is disconnected or open or the auxiliary relay is shorted. Call for service.
"CHEC"	The electrical compartment ambient temperature is above 140° F (60° C). All heaters will shut off. Check for proper airflow. Call for service.
"PO"	The incoming voltage has dropped below 175 VAC. All heaters will shut off. Call for service.

Table 1

	<p>If the toaster control board resembles the NEW style shown here, refer to the Fault Message in Table 2.</p>
FAULT CODE ON DISPLAY	POSSIBLE CAUSE(S)
Err 1	Failed Control Board (Call for Service)
Err 2	Failed Control Board (Call for Service)
Err 3	The programming dip switches were not adjusted upon installation of the universal control board. The dip switches must be adjusted to match the toaster Mfg #. Refer to document P/N 1011052 for specific settings.
Err 4	Platen Thermocouple is shorted to chassis ground (Call for Service)
Err 5	Platen Thermocouple is Loose or Disconnected or Open (Call for Service)
Err 6	Failed Control Board (Call for Service)
Err 7	Failed Control Board (Call for Service)
Err 8	Failed Control Board (Call for Service)
Err 9	The programming dip switches were not adjusted upon installation of the universal control board. The dip switches must be adjusted to match the toaster Mfg #. Refer to document P/N 1011052 for specific settings. NOTE: If the dip switches were adjusted correctly, then the AC Isolator Board or its wiring is faulty. (Call for Service)
Err 10	Failed Control Board (Call for Service)
CHEC	Ambient in electrical compartment has exceeded 140 F (60 C). Check for proper airflow. (Call for Service)

Table 2

MAINTENANCE

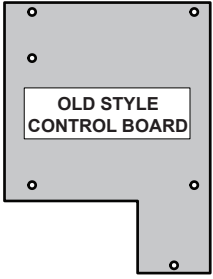
⚠ WARNING ⚠

Turn the power off, unplug the power cord, and allow the unit to cool down 30 minutes before performing any service or maintenance.

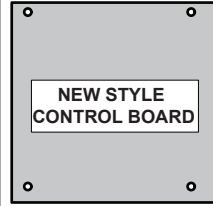
⚠ CAUTION ⚠

To prevent damage to the unit, do not use abrasive cleaners on the Release Sheet or Belt Wrap.

⚠ CAUTION ⚠

Failure to use Release Sheets may result in damage to the unit and loss of warranty coverage.

Daily

CLEANING THE BLACK AND SILVER RELEASE SHEET, CONVEYOR BELT WRAPS, AND TOASTER

Tools Required:

- Heat-resistant gloves
- Clean towels
- Multipurpose Detergent Solution
- Sanitizer Solution

1. Turn the Rocker Switch off, unplug the power cord, and allow the unit to cool for 30 minutes.
2. Put on heat-resistant gloves. Remove the Bun Feeder, Heat Shield, and Bun Chute (Figure 1). Wipe them with a damp sanitized towel and allow them to air dry.
3. Remove the Release Sheet and place it on a clean, flat dry surface. Wipe the silver side with a **clean** towel dampened with **Multipurpose Detergent Solution** immediately followed by a second clean towel dampened with sanitizer and allow it to air dry before continuing. Repeat this step on the black side of the Release Sheet once the silver side is dry.
4. Open the front Conveyor Cover and firmly wipe the black Belt Wrap from left to right and top to bottom with a clean towel dampened with **Multipurpose Detergent Solution** immediately followed by a second clean towel dampened with sanitizer.
5. Close the front Conveyor Cover, open the rear Conveyor Cover, and clean the Belt Wrap as described in Step 4.

6. Close the rear Conveyor Cover and reinstall the Heat Shield. Then plug in the power cord, turn the power on, count 10 seconds, turn the power off and unplug the power cord.
7. Open the rear Conveyor Cover again, clean the newly exposed section of the Belt Wrap in the same manner as before. Close the Conveyor Cover.
8. Open the front Conveyor Cover again and clean the newly exposed section of the Belt Wrap in the same manner as before.
9. Close the front Conveyor Cover and wipe down the outside of the toaster with a clean, damp, sanitized towel.
10. Install the Release Sheet by draping it over both sides of the Platen with the crease centered on the Platen.

NOTE: Rotate the Release Sheet from the black side to the silver side daily or weekly to prolong the life of the Release Sheet.

11. Install the Bun Chute so the hooks are installed over the lower Support Rod. Install the Heat Shield with the Release Sheet Retainer clips securely over the Release Sheet and Platen.
12. Reinstall the Bun Feeder and plug the power cord into the appropriate outlet.

NOTE: Make sure the Heat Shield is activating the Conveyor Safety Interlock Switch. The conveyors will not rotate unless the Heat Shield is in place and the Conveyor Safety Interlock Switch is activated.

NOTE: Check the Release Sheet to make sure it is not caught in the Conveyor. Additional Release Sheets can be obtained through your Authorized Service Agency under P/N 7000249 (3 Pack) or 7000250 (10 Pack).

MAINTENANCE (continued)

Replacing Black and Silver Release Sheet (Every 4 to 6 weeks)

NOTE: Depending on toaster usage and on how well it is cleaned daily, the black and silver Release Sheet should last between 45–60 days.

1. Remove and discard the Release Sheet.
2. Lay a new Release Sheet on a clean, dry surface and fold it in half lengthwise and gently crease it at the fold using only your fingers (Figure 7).
3. Install the Release Sheet.

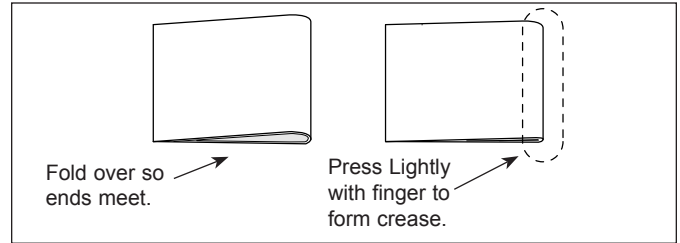

Figure 7. Folding Release Sheet

Replacing Belt Wraps (Every 3 to 6 months)

NOTE: Depending on toaster usage and how well they are cleaned daily, the Belt Wraps should last between 3–6 months. Additional Belt Wraps may be purchased from your Authorized Service Agency.

1. Turn the Rocker Switch off, unplug the power cord, and allow the unit to cool.
2. Remove the Bun Feeder and Heat Shield and set the Compression Control Knobs to 6 and F.
3. Open both Conveyor Covers and pull the Belt Wrap Pin out of the “zipper” (Figure 8).
4. Remove and discard the old Belt Wrap(s).
5. Clean both Conveyor Belt Chains just as you would clean the Belt Wraps during daily cleaning.
6. Install the new Belt Wrap(s) around the Conveyor Belt Chains inside the rods with the “zipper” flap exposed and hanging down (Figures 9 & 10).
7. Close the Conveyor Cover(s), set the Compression Control Knobs back to their normal settings and reinstall the Heat Shield and Bun Feeder.

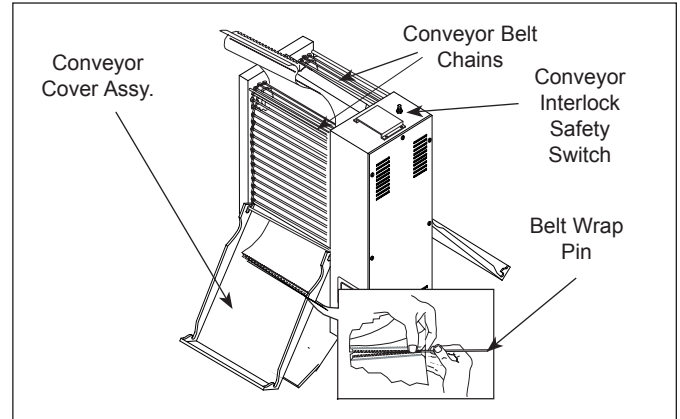

Figure 8. Removing Belt Wrap

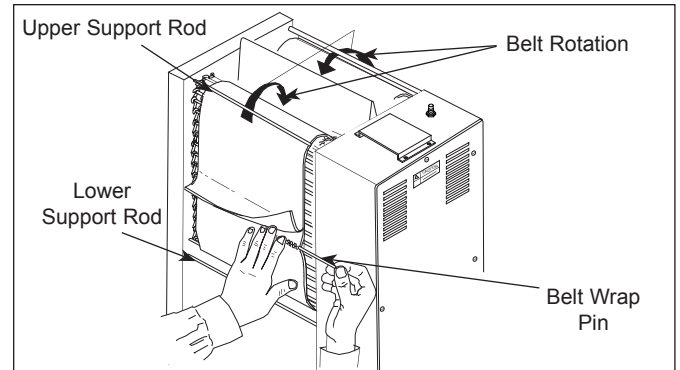

Figure 9. Installing Belt Wrap

⚠ CAUTION ⚠

Align the ends of the Belt Wrap properly (Figure 14) or the Belt Wrap may be damaged. Position the Belt Wrap between the upper and lower Support Rods or damage to the unit may occur.

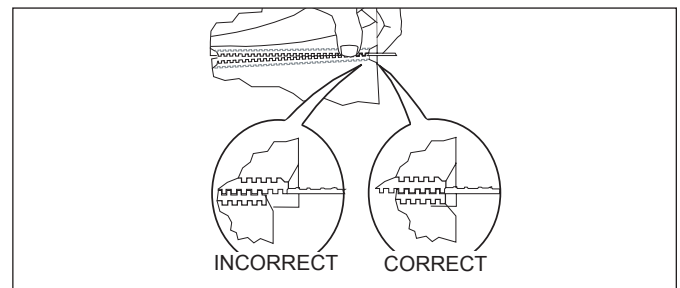

Figure 10. Aligning Belt Teeth

MAINTENANCE (continued)

⚠ WARNING ⚠

Turn the power off, unplug the power cord and allow the unit to cool down before performing any service or maintenance.

Conveyor Belt Chains (Every 3 to 6 months)

MEASURING CONVEYOR BELTS CHAINS

1. Set the compression knobs to 6 and F.
2. Open the Front Conveyor Cover and locate the approximate center point of the Conveyor Chain.
3. Pull the Conveyor Belt Chain away from the edge of the toaster.
4. Stand a U.S. Dime 11/16" (18 mm) coin on end between the frame and the chain (Figure 11).
5. If the gap is significantly than the coin, adjust the Conveyor Belt Chain as described below.
6. Use the same steps to check the rear Conveyor Chain.

ADJUSTING CONVEYOR BELT CHAINS

After a time, the Conveyor Chain links will wear and the Conveyor Belt chain will stretch, eventually skipping on the sprockets. This is easily remedied by removing one or more conveyor links from each side of the belt. There are two 1/2" small links on each side of the conveyor belt. The others are large, 3/4" long (Figure 12).

1. Turn the Rocker Switch off, unplug the power cord, and allow the unit to cool.
2. Remove the Bun Feeder and Heat Shield and set the Compression Control Knobs to 6 and F.
3. Open both Conveyor Covers and pull the Belt Wrap Pin out of the "zipper" (Figure 8).
4. Remove and the Belt Wrap(s).
5. Disconnect the Conveyor Belt Chain by squeezing any two links together and unhooking both ends of one link (Figure 12).
3. To shorten a stretched Conveyor Belt Chain, remove one 1/2" link from the belt.
4. Reassemble the Conveyor Belt Chain onto the sprockets as described below.

NOTE: If the belt is too short to be reassembled, remove an additional 1/2" small link and install a 3/4" large link. This will shorten the belt 1/4" overall.

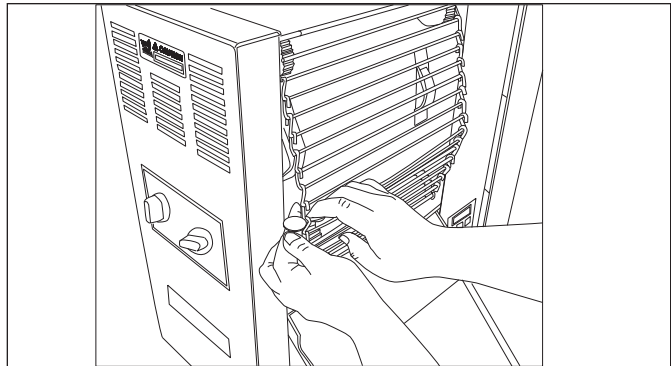

Figure 11. Removing Conveyor Belt Chains

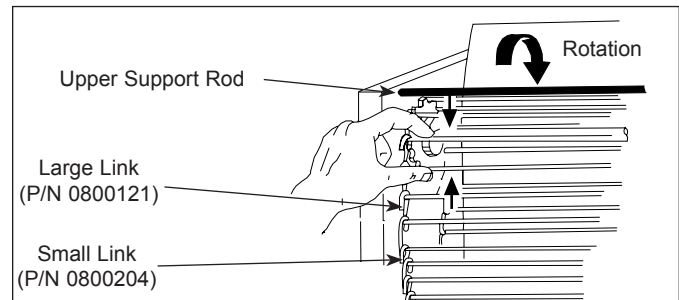

Figure 12. Removing Conveyor Belt Chains

REPLACING CONVEYOR BELT CHAINS

1. Turn the Rocker Switch off, unplug the power cord, and allow the unit to cool.
2. Remove the Bun Feeder and Heat Shield and set the Compression Control Knobs to 6 and F.
3. Open both Conveyor Covers and pull the Belt Wrap Pin out of the "zipper" (Figure 8).
4. Remove and the Belt Wrap(s).
5. Disconnect the Conveyor Belt Chain by squeezing any two links together and unhooking both ends of one link (Figure 12).
6. Remove the Conveyor Belt Chain.
7. Place the new Conveyor Belt Chain on the top sprockets with hook ends down. Check for correct positioning (Figure 12).

NOTE: The ends of the hooks must point down. (Figure 12).

8. Wrap the Conveyor Belt Chain around lower sprockets and connect by hooking both ends together.

NOTE: Make sure the Conveyor Belt Chain is installed under the upper Support Rod and over the lower Support Rod.

MAINTENANCE (continued)

Roller Tensioners (Every 3 to 6 months)

MEASURING ROLLER TENSIONERS

1. Measure the Roller Tensioner on both inner Conveyor Covers (Figure 13). The space between the inner Conveyor Cover and bottom of the tensioner wheel should be $13/16$ " (2.1 cm) or the height of a U.S. Nickel. Adjust or replace any damaged ones as recommended.

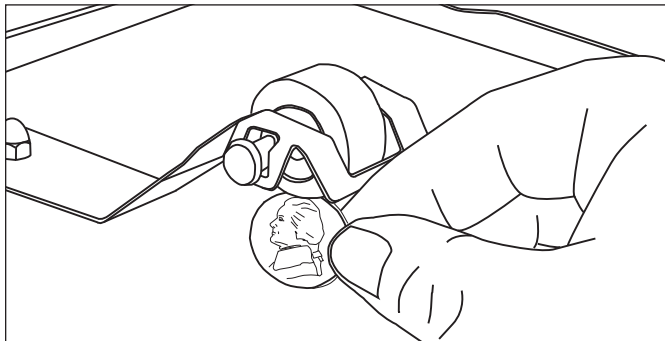

Figure 13. Measuring Roller Tensioner Assy.

REPLACING ROLLER TENSIONERS

1. Remove the Acorn Nuts and old Roller Tensioner Assembly (Figure 14).
2. Replace with the new Roller Tensioner Assembly, and reassemble.
3. Make sure the spacers are placed inside the tensioner arm. The spacers are smaller than the holes to allow the tensioner to pivot freely.

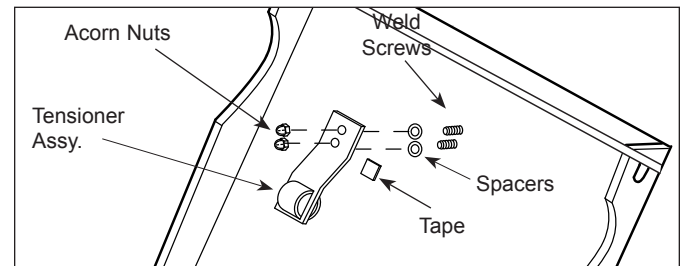

Figure 14. Replacing Roller Tensioner Assy.

TROUBLESHOOTING

⚠ WARNING ⚠

To avoid possible personal injury and/or damage to the unit, inspection, test and repair of electrical equipment should be performed by qualified service personnel. The unit should be unplugged when servicing, except when electrical tests are required. Use extreme care during electrical circuit tests. Live circuits will be exposed.

Problem	Possible Cause	Corrective Action
Control Display flashes “LO” continuously Buns not toasting properly.	Platen temperature is below 440°F (226°C).	Allow the unit to warm up for 30 minutes and then recheck. If the Control Display still reads “LO” contact your maintenance person or Authorized Service Agency for service.
Control Display flashes “LO” continuously. Buns burn.	Failed Platen Thermocouple.	Contact your maintenance person or Authorized Service Agency for service.
	Failed Control Board.	
Temperature Display flashes “PH”.	The Heat Shield is not fully engaging the Conveyor Safety Interlock Switch.	Reposition the Heat Shield so that it fully engages the Conveyor Safety Interlock Switch.
	Loose wiring between the phase control and A/C isolator boards.	Contact your maintenance person or Authorized Service Agency.
Control Display flashes “PO” continuously.	The power to the unit is below 190 volts.	Turn the Rocker Switch off and then back on. If the display still shows “PO” check the power cord, plug, and outlet for damage.
	Failed Control Board.	Reset the Circuit Breakers.
	Failed Transformer.	Contact your maintenance person, Authorized Service Agency, or electrician for service.
Control Display flashes “CHEC” continuously.	Control Compartment temperature is above 140°F (60°C).	Verify side vents on toaster are unblocked and not near other heating appliances. If problem still persists, contact your maintenance person or Authorized Service Agency for service.
	Failed Cooling Fan.	
	Failed Control Board.	
Control Display flashes “HI” continuously. Buns burn.	Failed Platen Solid State Relay.	Contact your maintenance person or Authorized Service Agency for service.
	Failed Control Board.	
	Failed Platen Thermocouple.	
Control Display flashes “HI” continuously. Buns not toasting properly.	Loose Platen Thermocouple connection on Control Board or the Platen Thermocouple is open.	Re-secure the Platen Thermocouple connection to the Control Board. If the Control Display still reads “HI” check the Thermocouple for continuity. Contact your maintenance person or Authorized Service Agency for service.
	Failed Control Board.	
Control Display flashes “HI” & “LO” at cold start up, then “HI” & “USE” after 20–30 minutes.	Loose Auxiliary Thermocouple connection on Control Board or Thermocouple is open.	Re-secure the Auxiliary Thermocouple connection to the Control Board. If the Control Display still reads “HI” & “LO” or “HI” & “USE”, check Thermocouple for continuity. Contact your maintenance person or Authorized Service Agency for service.

TROUBLESHOOTING (continued)

Problem	Possible Cause	Corrective Action
No Control Display.	Unit not plugged in.	Plug unit into the proper electrical outlet.
	Hi-Limit control has tripped.	Allow unit to cool and reset the Hi-Limit control. If it trips again, contact your maintenance person or Authorized Service Agency.
	Circuit Breakers turned off or tripped. Damaged electrical outlet, plug, or cord. Power On/Off Rocker Switch damaged.	Reset Circuit Breakers. If they trip again, check the cord, plug, and outlet for damage. Contact your maintenance person, Authorized Service Agency, or electrician.
Conveyor does not turn.	Safety Interlock Switch is not activated.	Reposition the Heat Shield properly.
	Heat Shield is bent or damaged.	Replace Heat Shield (P/N 0011528).
	Damaged or Missing Roller Tensioner(s).	Adjust or replace Roller Tensioner(s).
	Conveyor Belt/Chain has stretched. Chain skipping on sprockets.	Measure and adjust the Conveyor Belt Chains as described in the Maintenance section of this manual.
	Motor Drive Chain came off Sprocket(s).	Reinstall Drive Chain.
	Drive Chain needs lubrication.	Lubricate chain with Lubit-8 (P/N 2190152).
	Drive Motor has overheated.	Allow unit to cool and check Conveyor(s) for obstructions or binding at sprockets. Measure and adjust Conveyor Belt(s) as described in the Maintenance section of this manual.
	Drive Motor has failed.	Contact your maintenance person or Authorized Service Agency for service.
Buns not toasting adequately	Compression Settings are incorrect.	Use the recommended settings. Set Heel to 2 and Crown to 6.
	Temperature Setting is incorrect.	Verify that the Platen (SP-P) is set to 600°F (320°C) and the Auxiliary (SP-A) is set to 400°F (204°C). For making changes in the setpoint temperature, see the Installation section of this manual.
	Release Sheet is worn or needs cleaning (replace every 4–6 weeks).	Inspect Release Sheet for cleanliness, worn spots, tears, or wrinkles. Clean or replace Release Sheet as described in the Maintenance section of this manual.
	Belt Wraps are worn or need cleaning (replace every 3–6 months).	Replace or clean Belt Wraps as described in the Maintenance section of this manual.
	Belt Wraps are not tacky/sticky.	Clean or replace Belt Wraps as described in the Maintenance section of this manual.
	Buns do not meet specifications.	Contact your bun supplier.
	Non-OEM Release Sheets used.	Use only OEM Release Sheets (P/N 7000249 or 7000250).

TROUBLESHOOTING (continued)

Problem	Possible Cause	Corrective Action	
Crowns and/or Heels must be forced into the toaster. Buns sticking and burning.	Belt Wraps not being cleaned properly.	Clean Belt Wraps as described in the Maintenance section of this manual.	
	Conveyor Belt Wraps are not tacky/ sticky (replace every 3–6 months).	Clean Belt Wraps. If the Belt Wraps are too worn, replace them as described in the Maintenance section of this manual.	
	Belt Wraps are dirty, worn, or damaged (replace every 3–6 months).	Clean or replace Belt Wraps as described in the Maintenance section of this manual.	
	Release Sheet is not being cleaned properly.	Clean both sides of the black and silver Release Sheet as described in the Maintenance section of this manual.	
	Release Sheet is not being reversed as required.	Reverse the Release Sheet or replace Release Sheet as described in the Maintenance section of this manual.	
	Release Sheet is dirty, worn, or damaged (replace every 4–6 weeks).	Clean or replace Release Sheet as described in the Maintenance section of this manual.	
	Conveyor Belt Chains are skipping on Sprockets.	Measure and adjust the Conveyor Belt Chains as described in the Maintenance section of this manual.	
	Conveyor Safety Interlock Switch is not being activated by the Heat Shield.	Heat Shield is ajar. Reposition Heat Shield.	
		Heat Shield is damaged. Replace if necessary. If the Conveyor Safety Interlock Switch is damaged, contact your maintenance person or Authorized Service Agency for service.	
	Belt Wraps slipping over Conveyor Belt Chains.	Remove Belt Wraps and clean the Conveyor Belt Chain links and Belt Wraps as described in the Maintenance section of this manual.	
	Roller Tensioner(s) damaged or missing.	Reinstall or replace Roller Tensioner(s) as described in the Maintenance section of this manual.	
	Drive Motor stalls intermittently.	Contact your maintenance person or an Authorized Service Agency for service.	
	Compression Settings are incorrect.	Use the recommended settings. Set Heel to 2 and Crown to 6.	
	Buns are not inserted into the toaster properly.	Buns must be inserted with the cut sides facing each other on the correct Heel or Crown side.	
Using incorrect or damaged Belt Wraps.	Replace with OEM P/N 7000192 only.		
New Conveyor Belt Wraps do not fit.	Compression Settings are incorrect.	Set Compression Knobs to 6 and F when replacing Belt Wraps or when adjusting Conveyor Belt Chains.	
	Belt Wraps not installed correctly.	Install Belt Wraps inside the Rods with the “zipper flap” exposed and hanging down.	
	Using incorrect or damaged Belt Wraps.	Replace with OEM P/N 7000192 only.	

TROUBLESHOOTING (continued)

Problem	Possible Cause	Corrective Action
Toaster makes unusual sounds.	Compression Settings are too tight.	Set Compression Settings to the correct (or larger) setting.
	Conveyor Belt Wrap is installed incorrectly.	Belt Wraps must be installed as described in the Maintenance section of this manual.
	Belt Wrap Pin rubbing on housing.	Center the Pin in the Belt Wrap "zipper."
	Roller Tensioner(s) bent or missing.	Measure, adjust, or replace the Roller Tensioner(s) as described in the Maintenance section of this manual.
	Conveyor Belt Chains have stretched.	Measure and adjust the conveyor Belt Chains as described in the Maintenance section of this manual.
	Conveyor Belt Chains adjusted incorrectly.	
	Sugar and/or carbon has accumulated inside the Conveyor Belt Wrap and between the Conveyor Belt Chain and Tensioner Slide Rails.	Remove Belt Wraps, clean conveyor Belt Chain links just as you clean the Belt Wraps daily, and then clean the Slide Rails on the Tensioners. Next, clean the Belt Wrap on both sides before reinstalling it.
	Motor Drive Chain needs lubrication.	Lubricate the Drive Chain carefully with Lubit-8 (P/N 2140152) at least once a year.
	A Conveyor Shaft bearing is binding.	Contact your maintenance person or Authorized Service Agency for service.

REPLACEMENT PARTS

Parts Identification

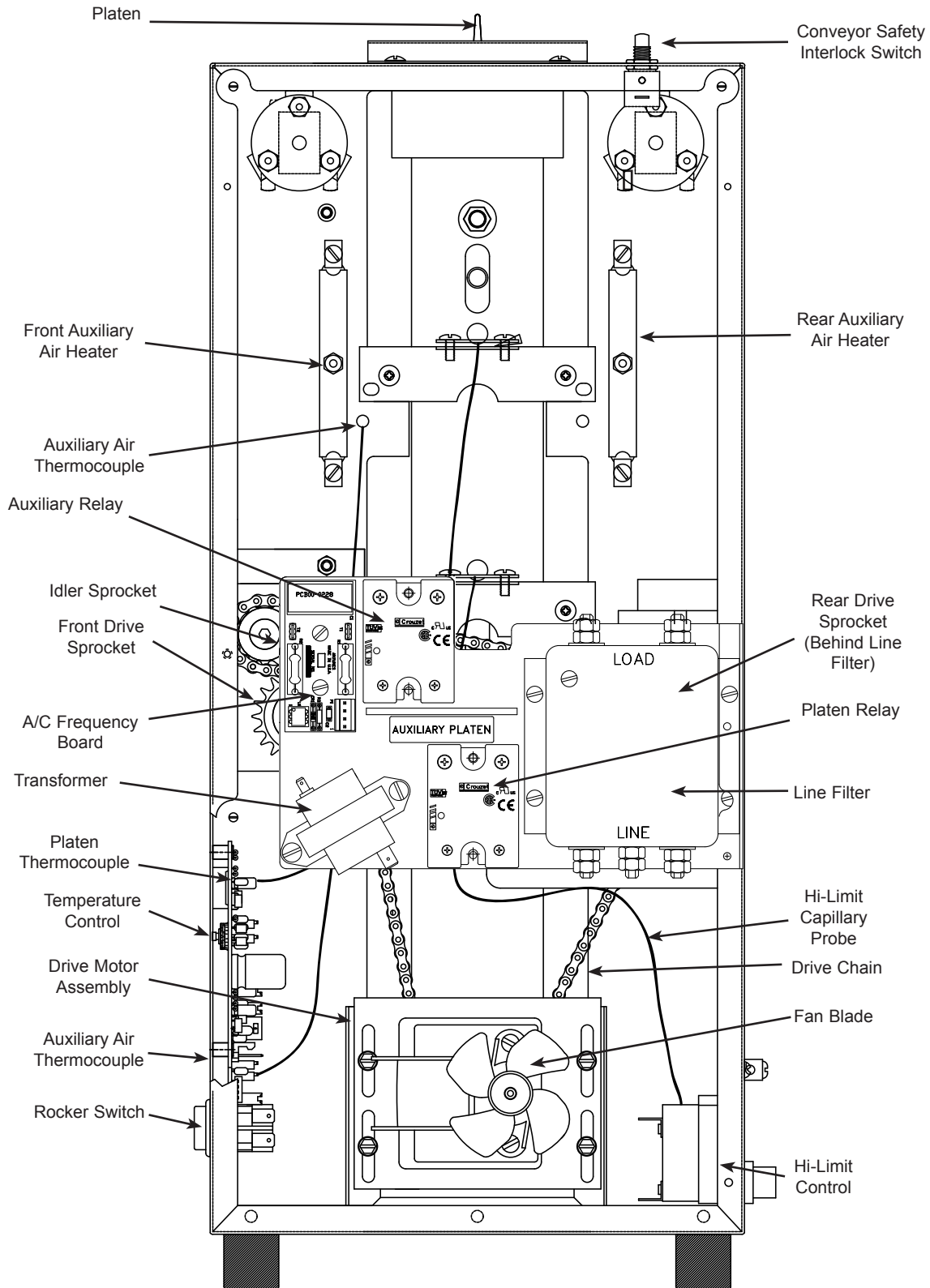

REPLACEMENT PARTS (continued)

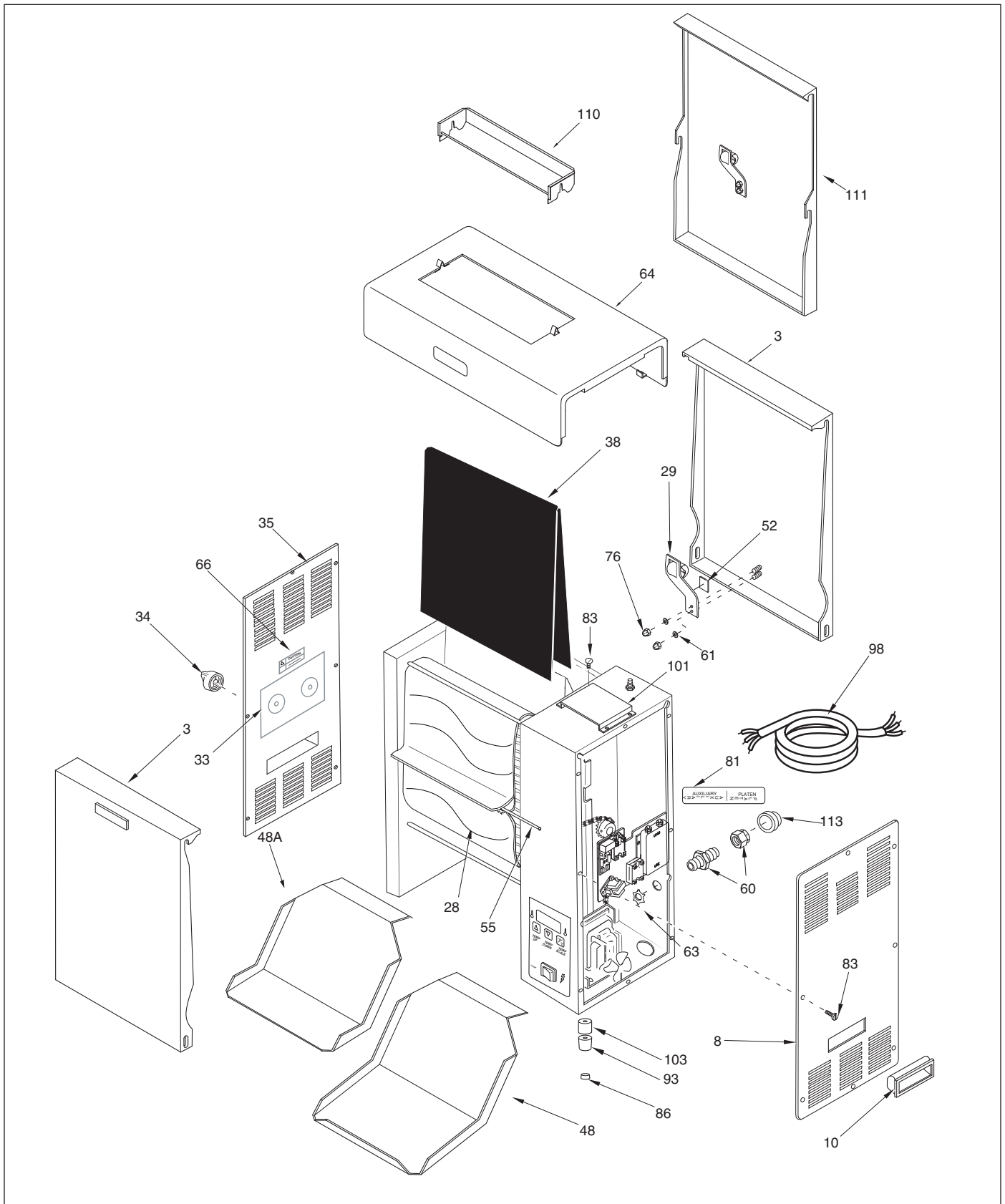

REPLACEMENT PARTS (continued)

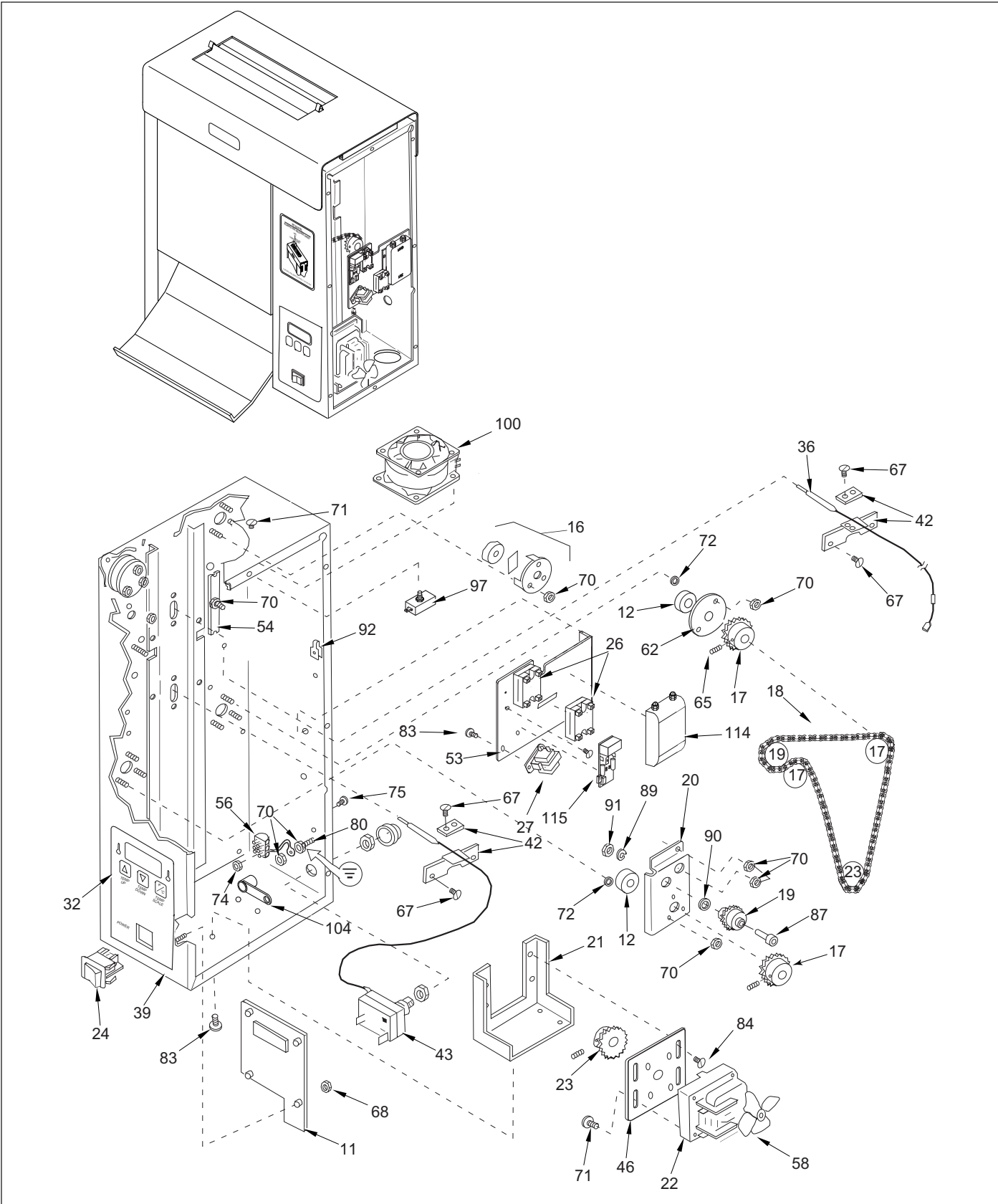

REPLACEMENT PARTS (continued)

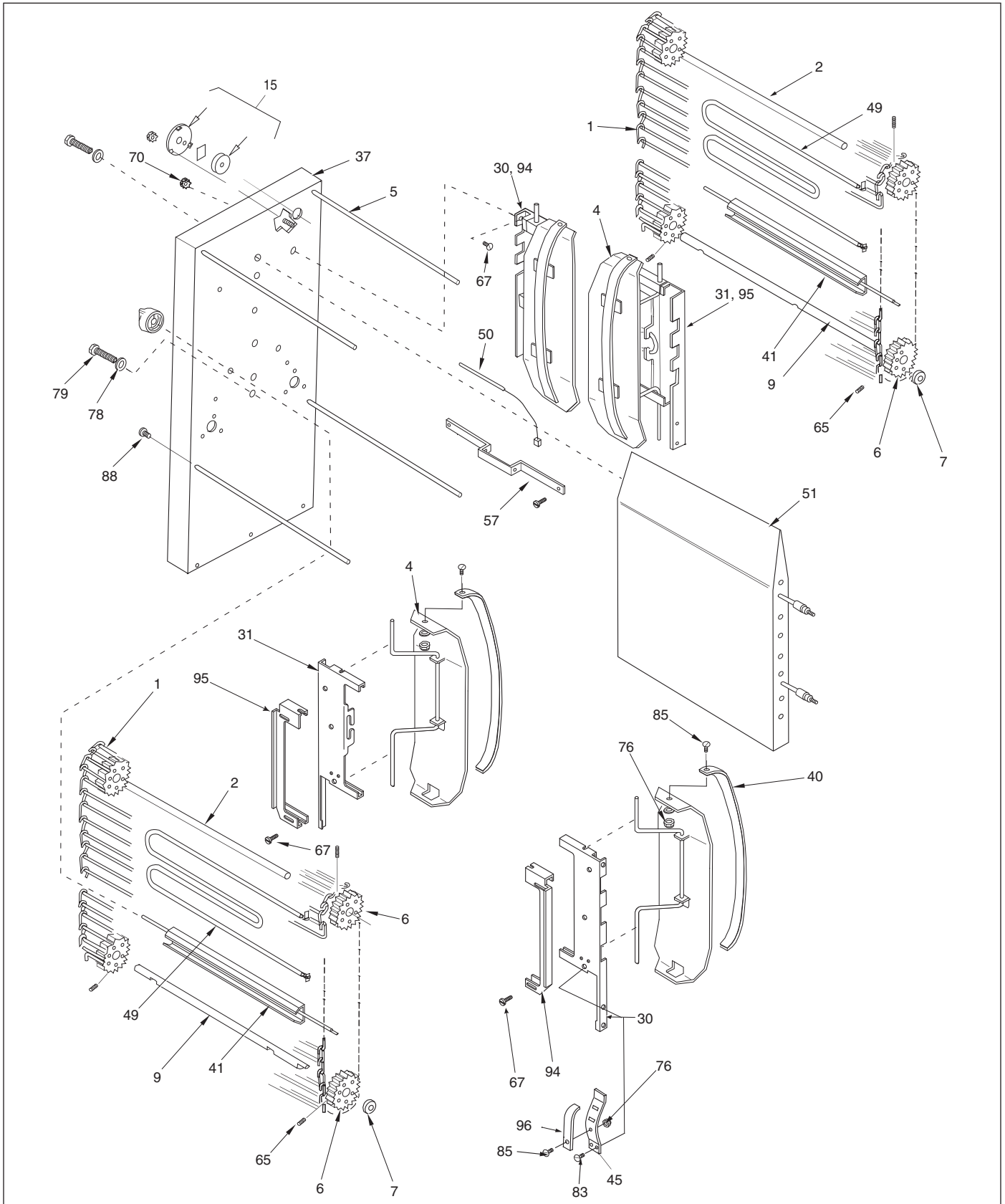

REPLACEMENT PARTS (continued)

Item	Part No.	Description	Qty.
1	0011266	Conveyor Belt (Incl. items below)	2
	0800204	1/2" Pitch Link, Small	2
	0800121	3/4" Pitch Link, Large	38
2	2150117	Idler Shaft	2
3	7000322	Conveyor Cover Assy. (Incl. #29, 52, 61 & 76)	2
4	0010475	Tensioner Assy. (Incl. #40, 76 & 85)	4
5	7000644	Rod, Conveyor Cover	4
6	7000207	Sprocket w/ Setscrew	8
7	7000199	Spacer Kit	1
8	0011444	Control Housing Cover Assy.	1
9	2150118	Drive Shaft	2
10	2100212	Handle	2
11	7000739	Control Board Kit	1
12	7000296	Ball Bearing (Pack of 2)	1
15	7000167	Bearing & Retainer Kit	6
15A	7000224	Bearing & Retainer Kit (Incl. six of #15)	1
16	7000539	Bearing & Spacer Kit (Incl. #11, 12, & 15)	1
17	2150181	Drive Sprocket	2
18	2150187	Drive Chain (Mfg. No. 9210212)	1
	2150215	Drive Chain (Mfg. No. 9210223)	1
19	0011299	Idler Sprocket & Bearing	1
20	0011300	Bracket, Idler Sprocket Assy. (Incl. #19, 87, 89, 90 & 91)	1
21	0503589	Bracket, Motor Mounting	1
22	7000240	Drive Motor Kit, Dual Frequency 50/60 Hz (Incl. #58) (Mfg. No. 9210212)	1
	0013281	Gearmotor Assembly, 230V/3RPM (Mfg. No. 9210223)	1
23	2150211	Sprocket w/Setscrew, 22 Tooth (Mfg. No. 9210212)	1
	2150120	Sprocket, w/Setscrew, 32 Tooth (Mfg. NO. 9210223)	1
24	7000542	Rocker Switch, On/Off (250 VAC)	1
26	7000370	Relay, Solid State	2
27	4010187	Transformer	1
28	7000416	Conveyor Belt Wrap (Pack of 2)	1
29	7000186	Roller Tensioner Assy. (Pack of 2) (Incl. #52, 61 & 76)	1
30	0503496	Tensioner Bracket, Right	2
31	0503497	Tensioner Bracket, Left	2
32	1001006	Label, Control	1
33	1001144	Label, Dial Compression	1
34	2100253	Knob, Control	2
35	0011445	End Housing Cover Assy.	1
36	4050214	Thermocouple Platen Assy.	1
37	0021170	Weldment, End Housing	1
38	7000249	Release Sheet (Pack of 3)	-
	7000250	Release Sheet (Pack of 10)	-
39	0021169	Control Housing	1
40	7000121	Slide Rail Kit (Includes two Slide Rails for tensioners)	2
41	0021207	Conveyor Cam	2
42	7000176	Thermocouple Retainer Kit	2
43	4030332	High Limit Control	1
45	0503455	Tension Spring, Inner	4
46	0503590	Bracket, Motor	1
47	0700651	Wire Set (not shown)	1
48	0503385	Bun Chute	1
48A	0503677	Bun Chute	1
49	4030348	Auxiliary Heater, 675W/230V	2

Item	Part No.	Description	Qty.
50	7000165	Auxiliary Thermocouple Kit	1
51	7000289	Platen (230V)	1
52	2100252	Slip Strip	4
53	0504067	Bracket, Line Filter	1
54	0503150	Heater Clip	2
55	303P127*	Hinge Pin, Belt Wrap	2
56	4060355	Terminal Block	1
57	0503533	Bracket, Auxiliary Thermocouple	1
58	4000170	Fan Blade, Motor	1
60	0400315	Strain Relief (International)	1
61	05P2199*	Spacer	4
62	0500464	Retainer, Bearing	1
63	040P138*	Locknut, 1/2"	1
64	0011793	Heat Shield Assy.	1
65	325P163*	Setscrew, 1/4-28 x 5/16"	8
66	1001192	Label, Caution Hot	1
67	308P183*	Screw, Hex, #8-32 x 3/8"	2
68	304P105*	Nut, #4-40, "KEPS"	4
69	406P107*	Cable Tie	1
70	308P143*	Nut, #8-32, "KEPS"	6
71	310P103*	Screw, Hex, #10-32 x 1/4"	4
72	310P157*	Washer, #10	6
73	308P101*	Nut, #8-32	3
74	306P101*	Nut, Hex, #6-32	2
75	306P123*	Screw, #6-32 x 7/8"	2
76	308P145*	Nut, Hex Acorn, #8-32	14
77	100P900*	Label, Service	1
78	325P104*	Washer, 1/4"	4
79	325P109*	Screw, 1/4-20 x 1/2"	4
80	308P124*	Screw, 1-Way, #8-32 x 1/2"	1
81	10P1022*	Label, Heaters	1
82	310P180*	Screw, #10-32 x 1-3/4"	4
83	308P133*	Screw, #8-32 x 1/4"	1
84	308P157*	Screw, Tap, #8-32 x 3/8"	20
85	308P181*	Screw, Flat Hd., #8-32 x 3/8"	4
86	218P145*	Cover, Leg, Bumper	4
87	331P103*	Shoulder Bolt, 5/16-18 x 1"	1
88	306P105*	Screw, #6-32 x 1/2"	8
89	331P106*	Lockwasher, 5/16"	1
90	212P118*	Flat Washer, 5/16"	1
91	331P101*	Nut, Hex, 5/16 x 18"	1
92	300P102*	Nut, Tinnerman	2
93	210K230	Bumper, Recess Leg, 1" (qty. of 4)	1
94	0503495	Retainer, Tensioner Bracket, RH	1
95	0503507	Retainer, Tensioner Bracket, LH	1
96	2100259	Slide Bar	4
97	7000400	Interlock Switch	1
98	0700453	Power Cord	1
99	306P104*	Screw, #6-32 x 1/4"	6
100	4000202	Fan	1
101	0503775	Duct, Fan	1
102	1001056	Label, Crown & Heel	1
103	2120147	Leg Spacers	4
104	4060374	Ground Lug	1
106	7000397	Base Heater	1
109	1001023	Label, Caution HOT	1
110	7000450	Bun Feeder Kit	1
111	0011675	Extended Rear Cover	1
113	2180128	7/8" Hole Plug	1
114	4050229	Line Filter	1
115	7000391	A/C Frequency Board Kit	1
116	2140152	Lubit-8® Lubricant (not shown)	1

* Sold only as packages of 10.

WIRING DIAGRAM

Pictorial Wiring Diagram Heated Base Units

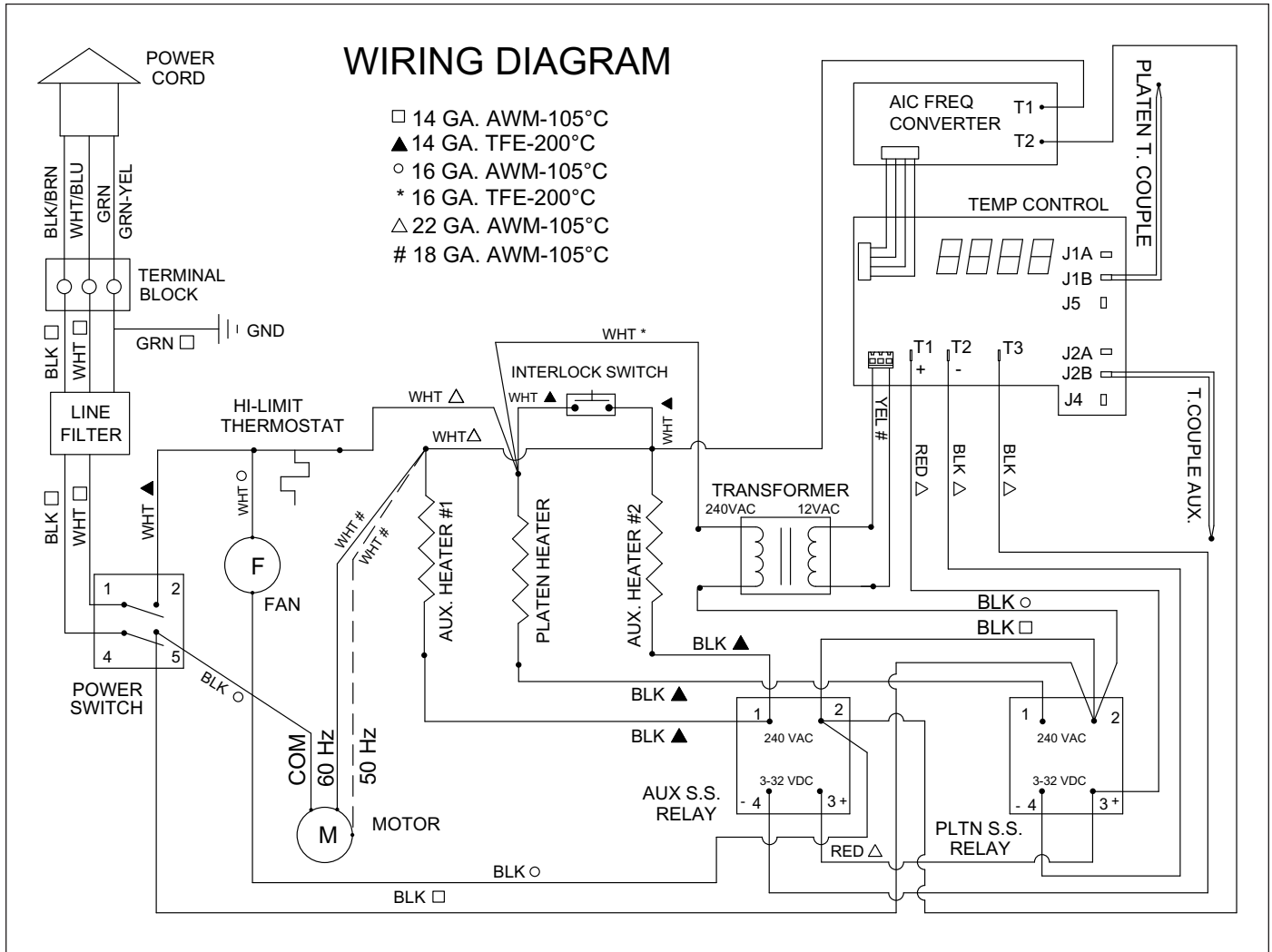

WIRING DIAGRAM (continued)

Pictorial Wiring Diagram Non-Heated Base Units

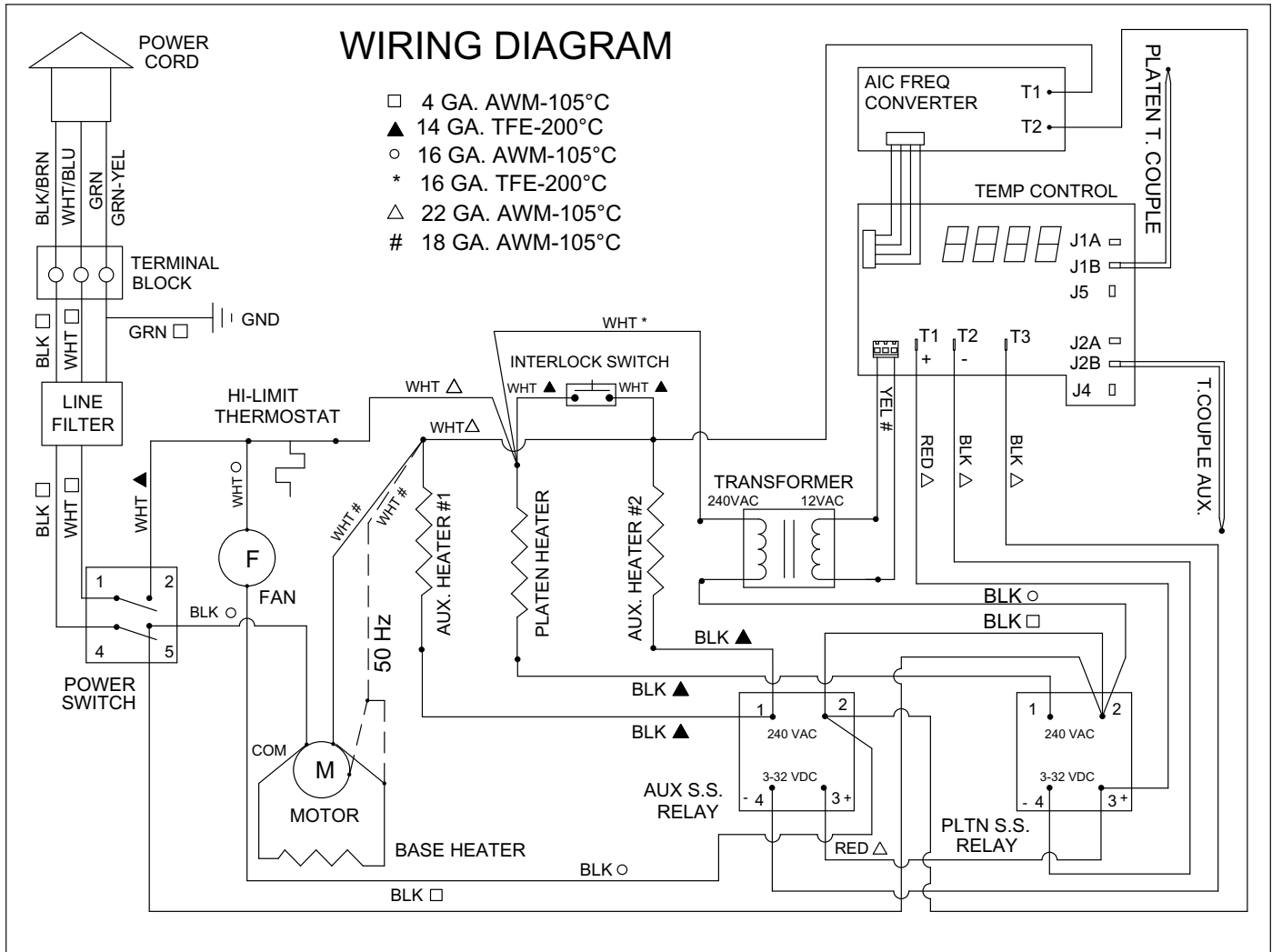

WIRING DIAGRAM (continued)

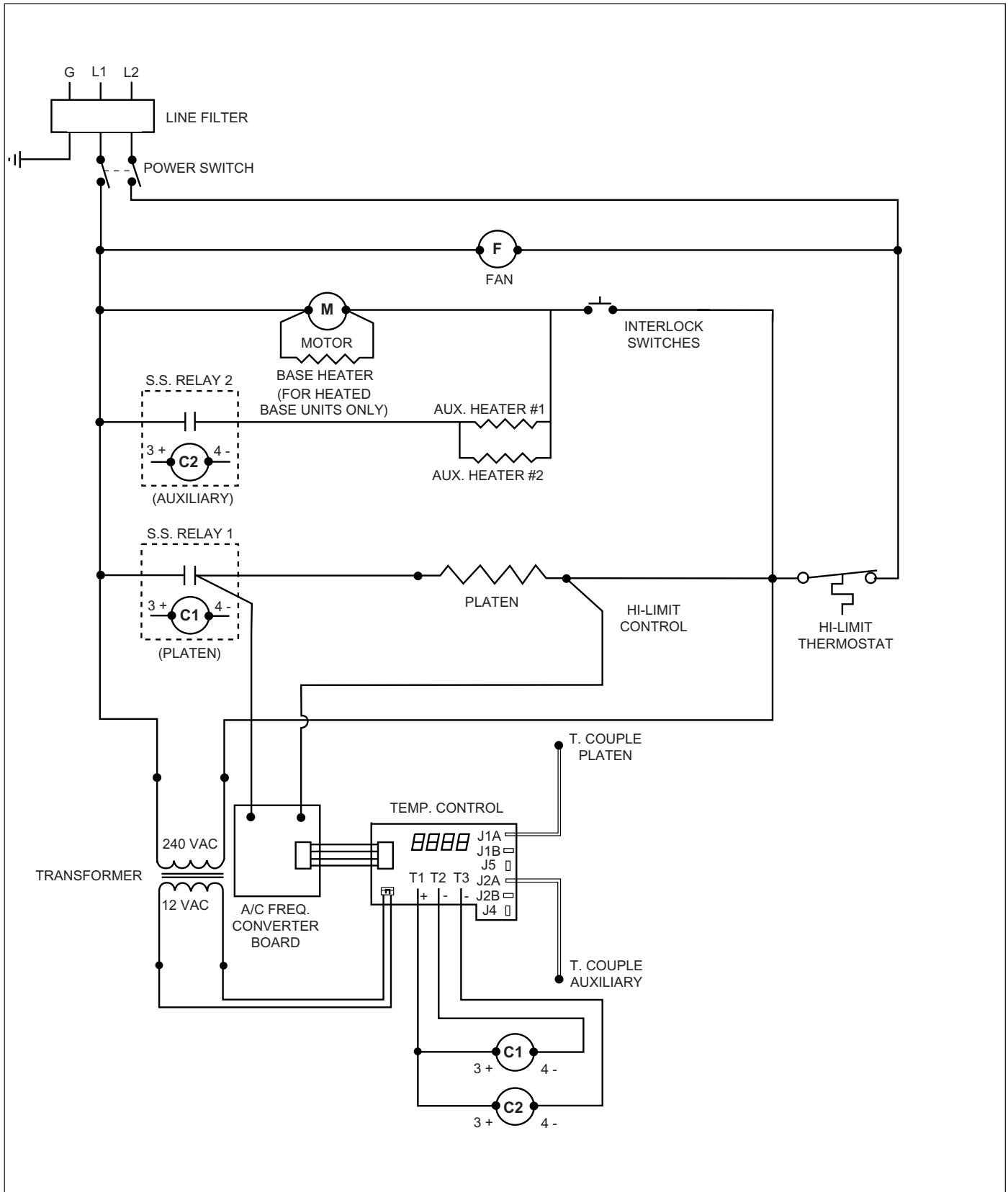

LIMITED WARRANTY

Equipment manufactured by Roundup Food Equipment Division of A.J. Antunes & Co. has been constructed of the finest materials available and manufactured to high quality standards. These units are warranted to be free from electrical and mechanical defects for a period of one (1) year from date of purchase under normal use and service, and when installed in accordance with manufacturer's recommendations. To insure continued operation of the units, follow the maintenance procedures outlined in the Owner's Manual. During the first 12 months, electro-mechanical parts, non-overtime labor, and travel expenses up to 2 hours (100 miles/160 km), round trip from the nearest Authorized Service Center are covered.

1. This warranty does not cover cost of installation, defects caused by improper storage or handling prior to placing of the Equipment. This warranty does not cover overtime charges or work done by unauthorized service agencies or personnel. This warranty does not cover normal maintenance, calibration, or regular adjustments as specified in operating and maintenance instructions of this manual, and/or labor involved in moving adjacent objects to gain access to the equipment. This warranty does not cover consumable/wear items. This warranty does not cover damage to the Load Cell or Load Cell Assembly due to abuse, misuse, dropping of unit/shock loads or exceeding maximum weight capacity (4 lbs). This warranty does not cover water contamination problems such as foreign material in water lines or inside solenoid valves. It does not cover water pressure problems or failures resulting from improper/incorrect voltage supply. This warranty does not cover Travel Time & Mileage in excess of 2 hours (100 miles/160 km) round trip from the nearest authorized service agency.
2. Roundup reserves the right to make changes in design or add any improvements on any product. The right is always reserved to modify equipment because of factors beyond our control and government regulations. Changes to update equipment do not constitute a warranty charge.
3. If shipment is damaged in transit, the purchaser should make a claim directly upon the carrier. Careful inspection should be made of the shipment as soon as it arrives and visible damage should be noted upon the carrier's receipt. Damage should be reported to the carrier. This damage is not covered under this warranty.
4. Warranty charges do not include freight or foreign, excise, municipal or other sales or use taxes. All such freight and taxes are the responsibility of the purchaser.
5. THIS WARRANTY IS EXCLUSIVE AND IS IN LIEU OF ALL OTHER WARRANTIES, EXPRESSED OR IMPLIED, INCLUDING ANY IMPLIED WARRANTY OR MERCHANTABILITY OR FITNESS FOR A PARTICULAR PURPOSE, EACH OF WHICH IS HEREBY EXPRESSLY DISCLAIMED. THE REMEDIES DESCRIBED ABOVE ARE EXCLUSIVE AND IN NO EVENT SHALL ROUNDUP BE LIABLE FOR SPECIAL CONSEQUENTIAL OR INCIDENTAL DAMAGES FOR THE BREACH OR DELAY IN PERFORMANCE OF THIS WARRANTY.



A.J. Antunes & Co.
Headquarters/Manufacturing
Carol Stream, Illinois 60188 USA
Phone: (630) 784-1000
Toll Free: (800) 253-2991
Fax: (630) 784-1650

Antunes Equipment
Manufacturing (Suzhou) Ltd.,
Suzhou, Jiangsu, China 215011
Phone: 86-512-6841-3637
Toll Free: 400-0-7878-22
Fax: 86-512-6841-3907

www.ajantunes.com