

Place this manual in the Toaster section  
of your Equipment Manual.  
Manufactured exclusively for  
McDONALD'S®

BY  
A.J. ANTUNES & CO.  
180 KEHOE BLVD.  
CAROL STREAM, ILLINOIS 60188, U.S.A.  
PHONE: 1-630-784-1000  
TOLL FREE: 1-877-392-7854  
FAX: 1-630-784-1650  
www.ajantunes.com



A.J. Antunes & Co.



UTX-200 & CTX-200

Scan with mobile device or enter URL  
for product and service information.

<http://tiny.cc/ajaUTX-CTX>

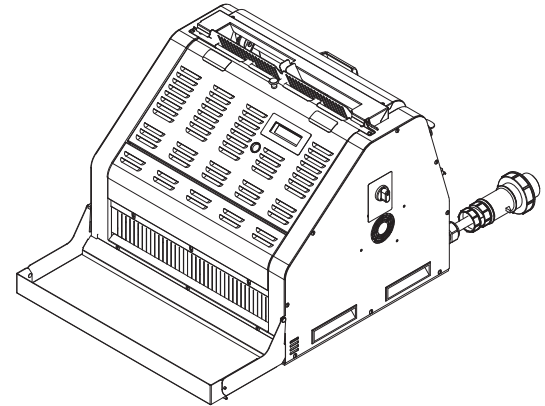

**TABLE OF CONTENTS**

<b>Owner Information</b> .....	<b>2</b>	Adjusting Toasting Quality .....	<b>10</b>
General .....	2	Viewing the Program Mode Settings .....	11
Warranty Information .....	2	Universal Toaster Settings .....	11
Service/Technical Assistance .....	2	UTX-200L Unit Status Mode .....	12
<b>Specifications</b> .....	<b>3</b>	Changing the Display Language .....	12
Electrical Specifications & Plug Configuration .....	3	Purging Products from the Toaster .....	12
Pass Through Time .....	3	Shutting down the UTX-200L .....	13
Dimensions .....	3	Reset to Factory Defaults .....	13
<b>Important Safety Information</b> .....	<b>4</b>	Adjusting the Upper and Lower I.R. ....	14
<b>Installation</b> .....	<b>5</b>	<b>Maintenance</b> .....	<b>15</b>
<b>Operation</b> .....	<b>7</b>	DAILY: Cleaning the Accessories, Release Sheet, and Vertical Conveyor Belt .....	15
Operating Instructions .....	7	WEEKLY & SEMI ANNUALLY: Clean Cooling Fans 16	
Switching Between Muffin and Bagel Mode .....	7	<b>Troubleshooting</b> .....	<b>17</b>
Breakfast to Lunch Change-over.....	8	<b>Replacement Parts</b> .....	<b>19</b>
Product Labels and Toasting Product .....	9		
Bun Thickness Compression Control Knob Settings	10		

**LIMITED WARRANTY**

The Antunes Food Service Equipment Division of A.J. Antunes & Co. provides the following limited warranty to the original purchaser of all McDonald's Equipment. All components are warranted against defects in the material and workmanship for a period of two (2) years from date of original installation.

If any part becomes defective during the period of this Warranty, Antunes Food Service will pay labor costs to an Authorized Service Agent to replace the part plus travel expenses.

**WARRANTY EXCLUSIONS**

- The cost of Installation.
- Equipment that has been damaged due to shipment. Purchaser should make damage claim directly upon carrier.
- Alteration, misuse, abuse.
- Improper storage or handling.
- Improper maintenance.
- Failure to follow proper Installation instructions, including electrical connection.
- Improper or unauthorized repairs.
- Scheduled Maintenance procedures as outlined in your MRC Card.
- This Warranty does not cover Consumable items. **NOTE: The Conveyor Belt wraps are consumable items that can be easily adjusted or replaced according to the Maintenance Section of this product's Owner's Manual.**
- Water pressure problems or contamination problems such as foreign material in water lines or inside solenoid valves due to an incoming water source.
- Freight, foreign, excise, municipal or other sales or use taxes.
- Consequential damages such as loss of profit, loss of time, the cost of repairing or replacing other property which is damaged, or any other incidental damage of any kind.

Antunes Food Service reserves the right to make changes in design or add improvements on any products. The right is always reserved to modify Equipment because of factors beyond our control and government regulation. Changes to Equipment do not constitute a warranty charge. This warranty is exclusive and is in lieu of all other warranties, expressed or implied, including any implied warranty of merchantability or fitness for a particular purpose, each of which is expressly disclaimed. The remedies described above are exclusive, and in no event shall A.J. Antunes & Co. or any of its Divisions be liable for special consequential or incidental damages for the breach or delay in the performance of this warranty.

**This manual is for the exclusive use of licensees and employees of McDonald's Systems, Inc..**

**© McDonald's Corporation All Rights Reserved**

**OWNER INFORMATION**

**General**

**This manual is produced for the Universal Toaster.**

The Universal Toaster is designed to toast a variety of buns (crowns and heels), bagels, and muffins. Its unique design allows the toaster to automatically switch temperatures and conveyors based on the choice of toasting zones made by the user. The Universal Toaster uses a combination of contact, impingement, and radiant toasting technologies to provide an evenly toasted product.

This manual provides the safety, installation, and operating procedures for the Universal Toaster. We recommend that this manual be read prior to installing and operating the unit.

The Universal Toaster is manufactured from the finest materials available and assembled to Roundup's strict quality standards. This unit has been tested at the factory to ensure dependable trouble-free operation.

**Warranty Information**

Please read the full text of the Limited Warranty in this manual.

If the unit arrives damaged, contact the carrier immediately and file a damage claim with them. Save all packing materials when filing a claim. Freight damage claims are the responsibility of the purchaser and are not covered under warranty.

The warranty does NOT extend to:

- Damages caused in shipment or damage as a result of improper use.
- Installation of electrical service.
- Normal maintenance as outlined in this manual.
- Malfunction resulting from improper maintenance.
- Damage caused by abuse or careless handling.
- Damage from moisture into electrical components.
- Damage from tampering with, removal of, or changing any preset control or safety device.

**Service/Technical Assistance**

If you experience any problems with the installation or operation of your unit, contact your Authorized Service Agency.

Fill in the information below and have it handy when calling your Authorized Service Agency for assistance. The serial number is on the specification plate located on the rear of the unit.

Purchased From: \_\_\_\_\_

Date of Purchase: \_\_\_\_\_

Model No.: \_\_\_\_\_

Serial No.: \_\_\_\_\_

Mfg. No.: \_\_\_\_\_

Network ID Number: \_\_\_\_\_

Refer to the service agency directory packaged with your manual and fill in the information below:

Authorized Service Agency

Name: \_\_\_\_\_

Phone No.: \_\_\_\_\_

Address: \_\_\_\_\_



Use only genuine Roundup replacement parts in this unit. Use of replacement parts other than those supplied by the manufacturer will void the warranty. Your Authorized Service Agency has been factory trained and has a complete supply of parts for this toaster.

You may also contact the factory at 1-877-392-7854 (North America only), or 630-784-1000 if you have trouble locating your nearest Authorized Service Agency.

**IMPORTANT! Keep these instructions for future reference. If the unit changes ownership, be sure this manual accompanies the equipment.**

## SPECIFICATIONS

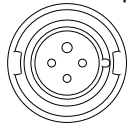
### Electrical Specifications & Plug Configuration

Model & Mfg. No	Line Voltage	Phase	Power	Max Amps/ Line	Freq.	Plug Description and Configuration
UTX-200L 9210805	208 V	3	8.6 kW	24	60	Pin & Sleeve 3 phase 
	240 V	3	10 kW	24	60	
UTX-200L 9210806	208 V	3	8.6 kW	24	60	NEMA L15-30P 
	240 V	3	10 kW	24	60	

### Pass Through Time

For all UTX-200 units the pass through time is 22 seconds (+/- 2 seconds).

### Dimensions

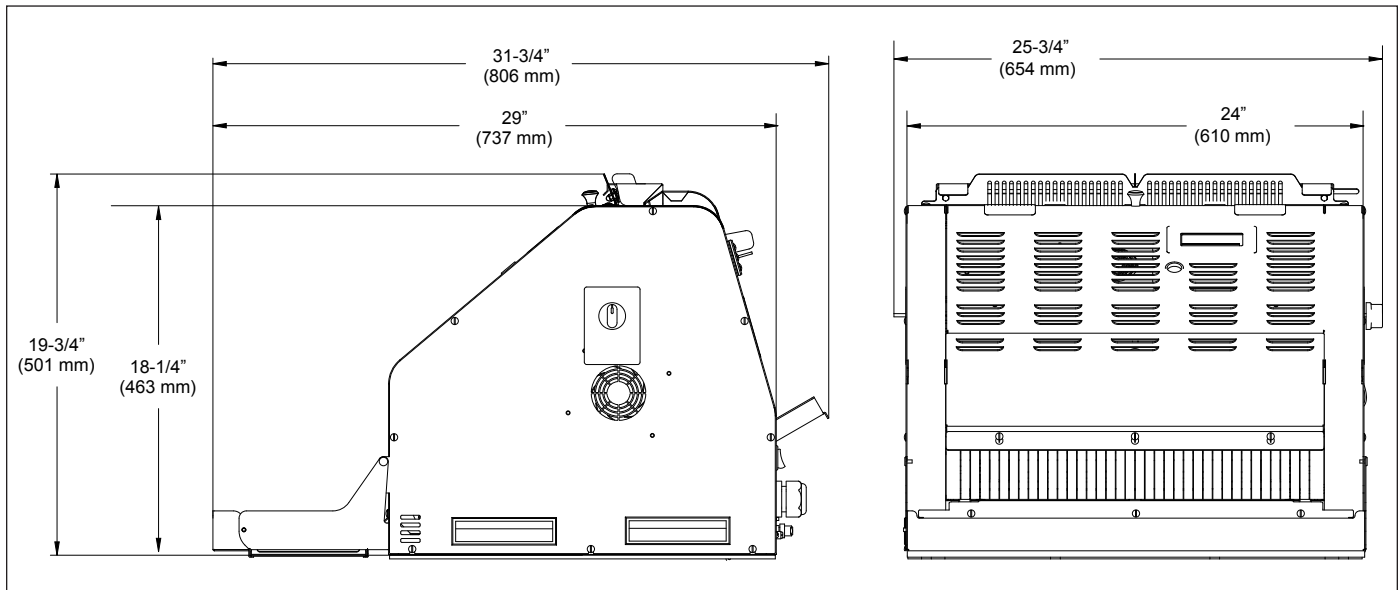

#### ⚠ WARNING ⚠

**ELECTRICAL SHOCK HAZARD. FAILURE TO FOLLOW THE INSTRUCTIONS IN THIS MANUAL COULD RESULT IN SERIOUS INJURY OR DEATH.**

- Electrical ground is required on this appliance.
- Do NOT modify the power supply cord plug. If it does not fit the outlet, have a proper outlet installed by a qualified electrician.
- Do NOT use an extension cord with this appliance.
- Check with a qualified electrician if you are unsure if the appliance is properly grounded.

#### ⚠ CAUTION ⚠

**All electrical connections must be in accordance with local electrical codes and any other applicable codes.**

**IMPORTANT SAFETY INFORMATION**

Throughout this manual, you will find the following safety words and symbols that signify important safety issues with regards to operating or maintaining the equipment.

**WARNING**

**GENERAL WARNING.** Indicates information important to the proper operation of the equipment. Failure to observe may result in damage to the equipment, severe bodily injury or even death.

**WARNING**

**ELECTRICAL WARNING.** Indicates information relating to possible shock hazard. Failure to observe may result in damage to the equipment and/or severe bodily injury or death.

**CAUTION**

**GENERAL CAUTION.** Indicates information important to the proper operation of the equipment. Failure to observe may result in damage to the equipment.

**WARNING**

**HOT SURFACE WARNING.** Indicates information important to the handling of equipment and parts. Failure to observe caution could result in personal injury.

In addition to the warnings and cautions in this manual, use the following guidelines for safe operation of the unit.

- Read all instructions before using equipment.
- For your safety, the equipment is furnished with a properly grounded cord connector. Do NOT attempt to defeat the grounded connector.
- Install or locate the equipment only for its intended use as described in this manual. Do NOT use corrosive chemicals in this equipment.
- Do NOT operate this equipment if it has a damaged cord or plug, if it is not working properly, or if it has been damaged or dropped.
- This equipment should be serviced by qualified personnel only. Contact the nearest Authorized Service Agency for adjustment or repair.
- Do NOT block or cover any openings on the unit.
- Do NOT immerse cord or plug in water.
- Keep cord away from heated surfaces.
- Do NOT allow cord to hang over edge of table or counter.
- Do NOT operate unit on a combustible counter top.
- Do NOT clean this appliance with a water jet.

The following warnings and cautions appear throughout this manual and should be carefully observed.

- Turn the power off, wait for the cool-down procedure to complete its cycle (45 minutes), and unplug the power cord before performing any service or maintenance on the unit.

**NOTE:** Turning off the power switch does NOT turn off all power to the unit. When the unit is plugged in and turned off, an LED light will flash to indicate that the power cord is plugged in.

- The procedures in this chapter may include the use of chemical products. These chemical products will be highlighted with bold face letters followed by the abbreviated **HCS** (Hazard Communication Standard). See Hazard Communication Standard manual for the appropriate Material Safety Data Sheets (MSDS).
- The equipment should be grounded according to local electrical codes to prevent the possibility of electrical shock. It requires a grounded receptacle with separate electrical lines, protected by fuses or circuit breaker of the proper rating.
- Bread may burn. Therefore toasters must not be used near or below curtains or other combustible walls and materials. Failure to maintain safe operating distances may cause discoloration or combustion.



**This equipotentiality symbol shows external functional grounding connection.**

**WARNING**

**To avoid possible personal injury and/or damage to the unit, all inspections, tests, and repair of electrical equipment should be performed by QUALIFIED SERVICE PERSONNEL. The unit MUST be shut down and UNPLUGGED before any internal servicing, except when electrical tests are required. Use extreme care during electrical circuit tests. Live circuits will be exposed.**

## INSTALLATION

**1**

Release Sheet (2)  
Bun Buffer  
Breakfast Chute  
Owner's Manual

**DO NOT DISCARD ACCESSORIES BOX!**

Open the Large Box. Remove and open the Accessory Box. Set accessories, parts, and manual aside.

**2**

Remove UTX-200L from box. Place in desired location. Wipe down the entire unit with a clean damp cloth.

**3**

**NOTE: Wash all metal accessories prior to installation!**

Bun Buffer

Wash all metal accessories in hot, soapy water and allow to air dry. Attach Bun Buffer to front of unit.

**4**

Breakfast Chute  
Crumb Tray

Insert Breakfast Chute over Crumb Tray **TAB END FIRST**. Hook the chute over the top of Crumb Tray. Slide Crumb Tray fully into unit.

**5**

Remove the knob closest to the CTX-200

Plug the Power Cord into the appropriate outlet

**NOTE:** CTX-200 can be placed to the left or right of UTX-200

Plug the power cord into the appropriate outlet.  
**If CTX-200L is present:** Remove Compression Knob from side of the UTX-200L closest to the CTX-200.  
Do NOT discard the knob.

**NOTE:** If any parts are missing or damaged, contact Technical Service **IMMEDIATELY** at 1-877-392-7854 (North America only), or 630-784-1000.

**CAUTION**

1. Provide at least 1 inch (25.4 mm) clearance on both sides of the UTX-200L (or CTX-200L if used with the UTX-200L) from any combustible wall or surface. Leave front and back open.
2. Do **NOT** operate unit on a combustible surface or counter top.

**WARNING**

Use caution while the unit is operating. The unit and accessories will be hot to the touch. Use Heat Resistant Gloves when removing any accessories while the unit is operating. Personal injury may result.

**INSTALLATION (continued)**

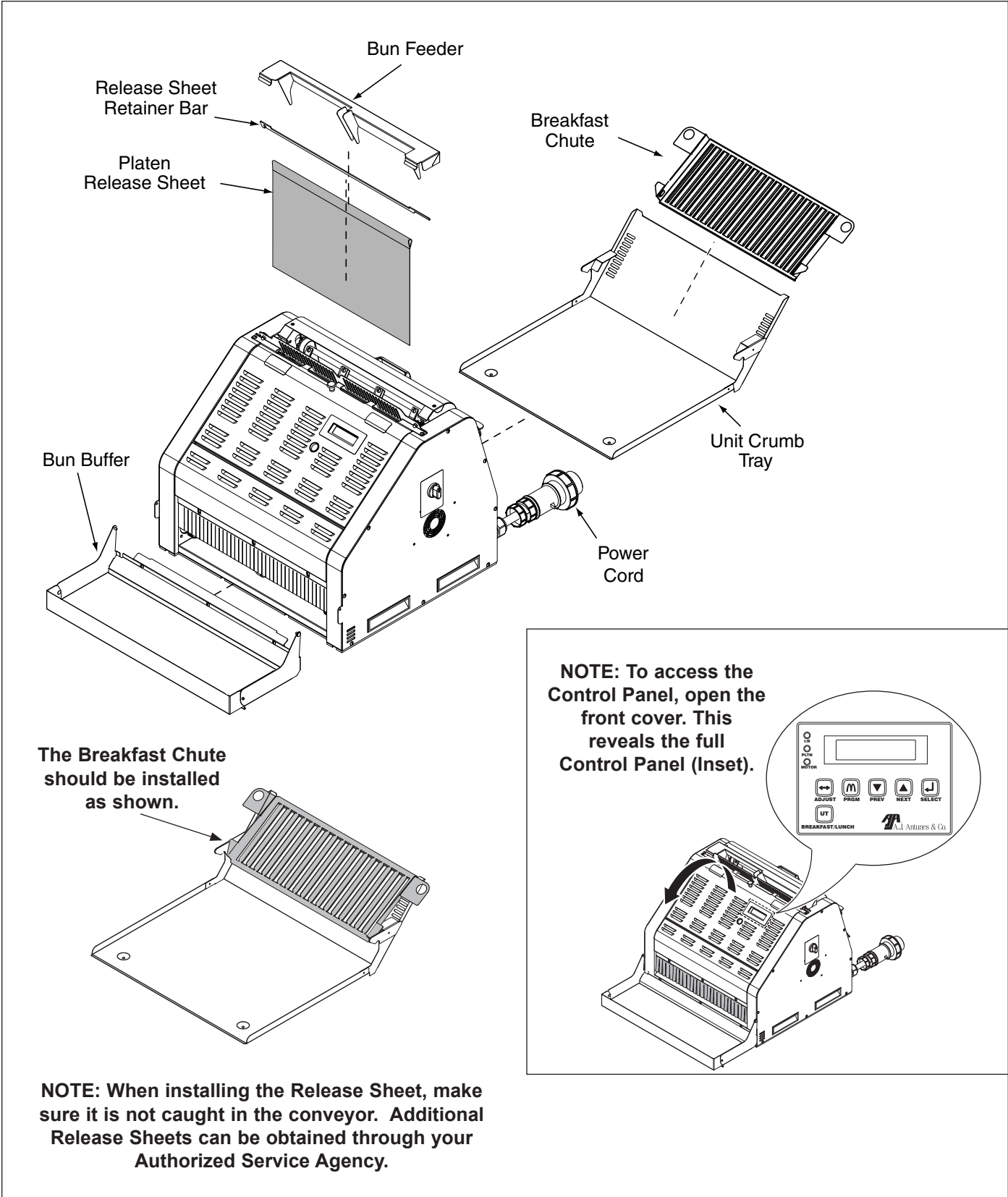

Figure 1. Universal Toaster Components

## OPERATION

### Operating Instructions

**NOTE:** To ensure proper operation, toast some test product at the start of each day or whenever the unit mode is changed.

**NOTE:** The UTX-200L has three operational modes: Bagel and Muffin (breakfast) and Lunch (crowns and heels). The unit always starts up in Muffin Mode.

**NOTE:** If the toasting quality needs adjustment, refer to *Adjusting Toasting Quality* in the Operation section of this manual.

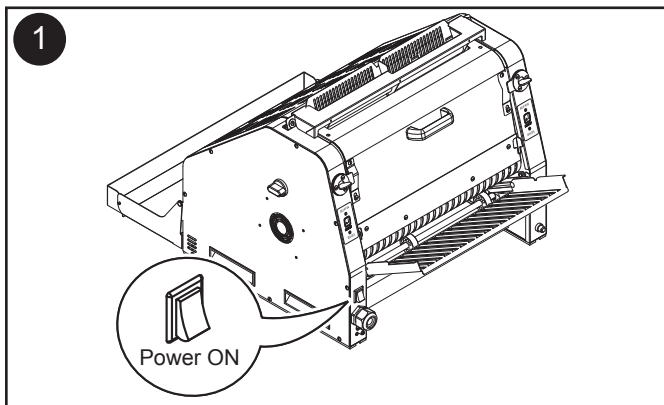

Turn the Power Switch On.  
The unit “clicks” three times. This is normal.

2

The unit displays this message for approximately 2 seconds.

The bottom line refers to the current software version

The unit performs a 20 second system check.

The bottom line refers to the current software version

The unit start up mode includes a 20-second system check.

3

Muffin Wait

After the system check, the unit displays the Muffin Wait message. The Muffin Wait message means the unit is warming up. This stage lasts approximately 20 minutes.

4

Muffin Ready

The unit displays the Muffin Ready message when it reaches proper operating temperature for Breakfast.

### Switching Between Muffin and Bagel Mode

1

MUFFIN

BAGEL

POWER ON

POWER OFF

Press one of the Muffin/Bagel Selector buttons to switch between Muffin and Bagel mode.

**OPERATION (continued)**

**Breakfast to Lunch Change-over**

Follow these steps to change from Breakfast mode to Lunch mode:

**NOTE: Do NOT toast any lunch products until the unit displays the Lunch Ready message.**

**1** Location of the UT Breakfast/Lunch Button

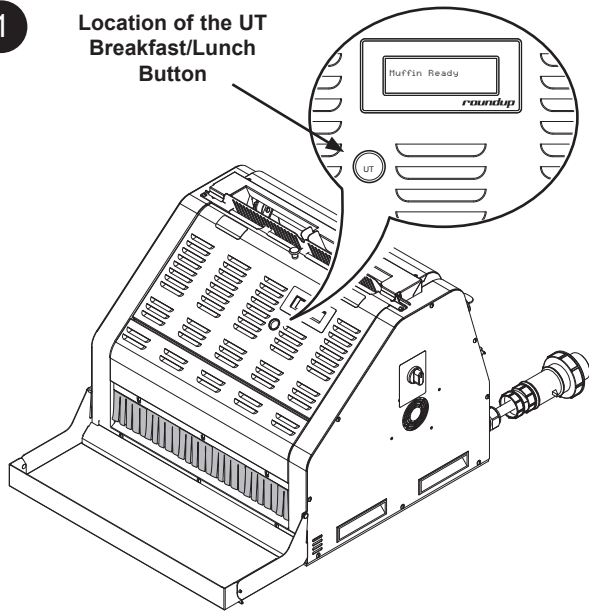

Press the UT Breakfast/Lunch button once to prepare the unit for Lunch mode.

**2** **COMPRESSION**

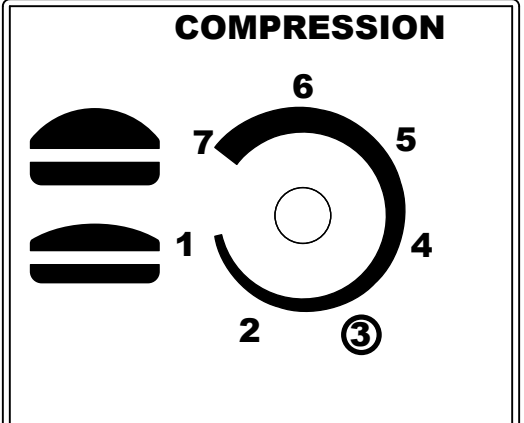

Set the Bun Thickness Compression Control knob to 3. This is used in Lunch mode ONLY.

**3**

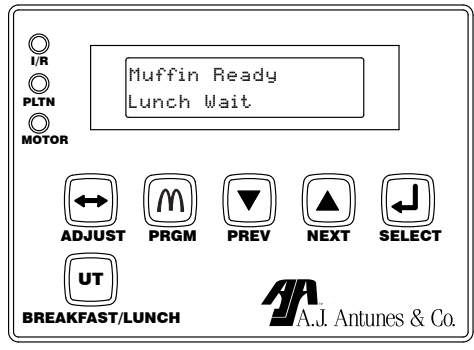

The unit warms up the toaster Platen for Lunch mode. The unit display the Muffin Ready / Lunch Wait message.

**4**

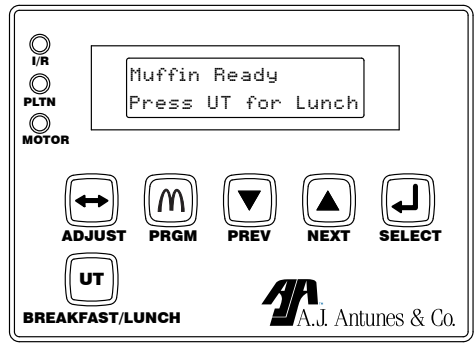

When the unit reaches lunch operating temperature, it displays the message above. Press the UT Breakfast/Lunch to start Lunch mode.

**5**

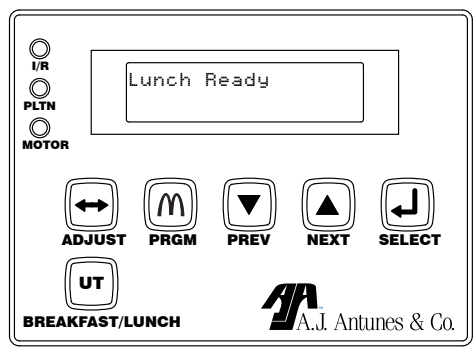

The unit is ready for lunch operation when the Lunch Ready message appears.

## OPERATION (continued)

### Product Labels and Toasting Product

The UTX-200L can toast Bagels, Muffins, Bun Crowns, and Bun Heels, but not all products are inserted into the toaster the same way.

Product Labels are placed on the toaster to illustrate where and how specific products should be inserted for proper toasting.

If the Product Label reads:	Then insert the product as follows:
Heel	Insert Heel with the cut side <b>facing</b> the Platen. Refer to the appropriate Product Label
Crown	Insert Crown with the cut side <b>facing</b> the Platen. Refer to the appropriate Product Label
Muffin	Insert the Muffin into the Breakfast Chute with the cut side face <b>UP</b> .
Bagel	Insert the Bagel into the Breakfast Chute with the cut side face <b>UP</b> .

Items 1, 2, and 3 in this section show how to insert product and product toasting routes.

**NOTE:** Always toast some test product at the start of each day or whenever the unit mode is changed to ensure proper toasting operation.

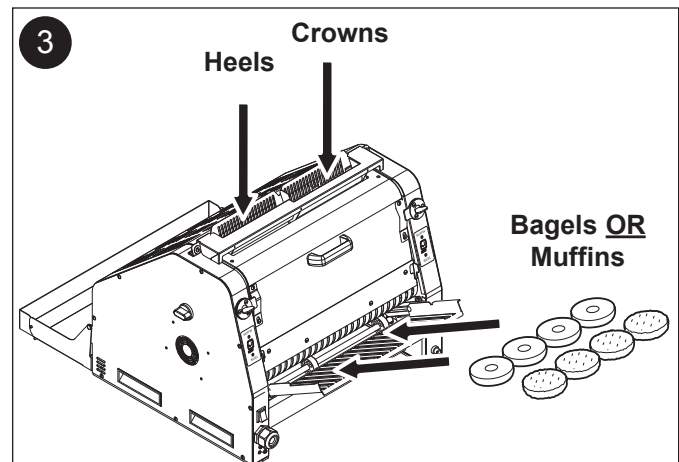
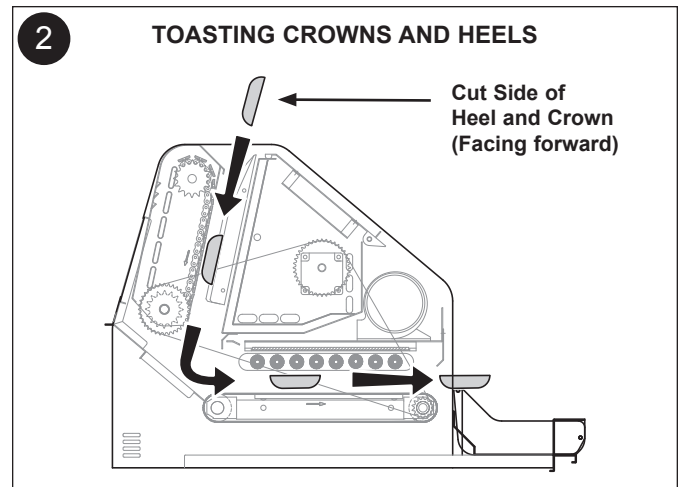
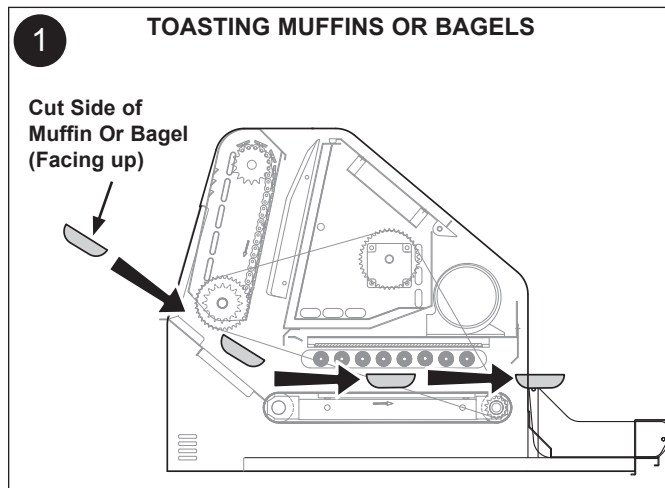

Insert Heels on the left side of the toaster only. Insert Crowns on the right side only.

### ⚠ IMPORTANT ⚠

The unit can toast 4 bagels or muffins across at a time. However, bagels and muffins should **NOT** be placed in the unit together. Use the Muffin Bagel Selector buttons to enter the appropriate mode for bagels or muffins.

**NOTE:** For all UTX-200 units, the product pass-through time is 22 seconds (+/- 2 seconds).

**OPERATION (continued)**

**Bun Thickness Compression Control Knob Settings**

During Lunch operation only, the UTX-200L uses a Bun Thickness Compression Control Knob for proper toasting of heels and crowns (Figure 2).

For best toasting quality, set the Bun Thickness Compression Control Knob to 3.

**NOTE: The Bun Thickness Compression Control Knob is NOT used during breakfast mode.**

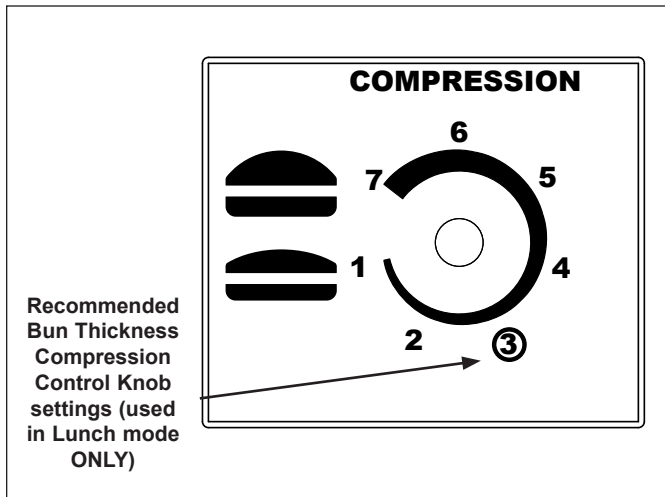

**Figure 2. Bun Thickness Compression Control**

The UTX-200L and the CTX-200L are designed to sit side by side. The CTX-200L can be placed on the right or left side of the UTX-200L by putting the Bun Thickness Compression Control Knob on the side of the UTX-200L that is NOT flush against the CTX-200L.

This allows you to customize unit placement to your preference by placing the Bun Thickness Compression Control Knob on either side of the UTX-200L. If used, the CTX-200L must be placed on the opposite side of the UTX-200L Bun Thickness Compression Control Knob.

**Adjusting Toasting Quality**

The toasting quality of the UTX-200L can be adjusted to provide a lighter or more darkly toasted product. Follow these steps to adjust toasting quality:

1. Open the Front Cover to access the Control Panel (Figures 3 and 4).

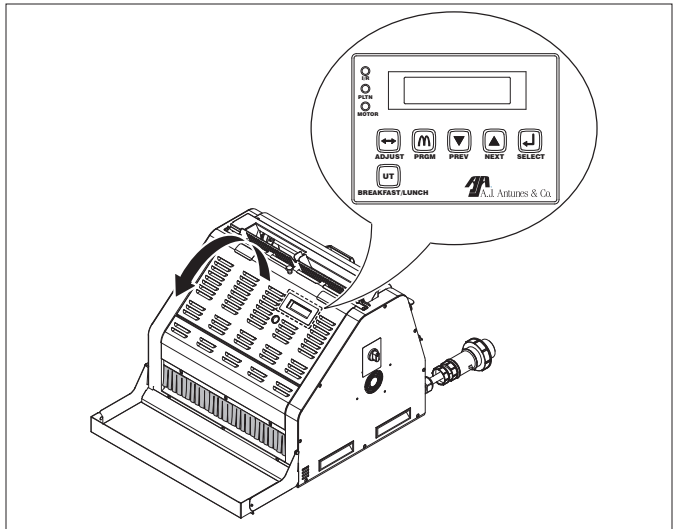

**Figure 3. Accessing the UTX-200L Control Panel**

2. Press and release the **ADJUST** button (Figure 4).
3. Use the **PREV** and **NEXT** buttons to adjust the toasting quality to lighter or darker respectively (Figure 4).

**NOTE: Pressing the PREV button decreases toasting darkness. Pressing the NEXT button increases toasting darkness. There are ten adjustment increments in each direction. Two bars will be lit when the adjustment is in the center.**

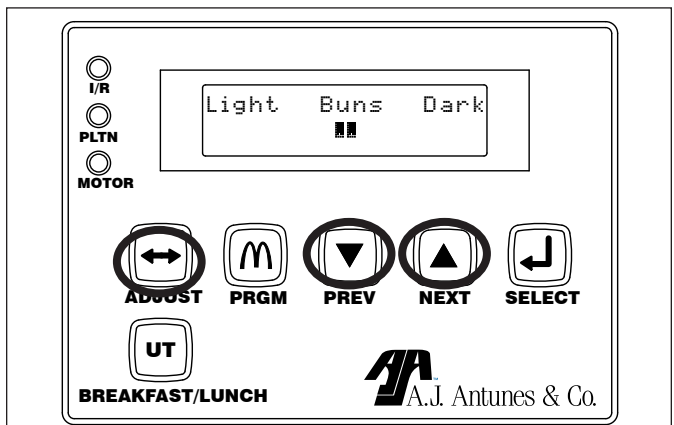

**Figure 4. Adjusting Toasting Quality**

## OPERATION (continued)

4. Test one or two buns to verify that the product is toasting with the desired quality.
5. If the toasting quality needs further adjustment, repeat Steps 2 through 4 as necessary.
6. Press the **PRGM** button when the adjustment is complete to return to Ready mode.

**NOTE: This setting is maintained when the unit is powered off.**

7. Press the **PRGM** button to exit.

### Viewing the Program Mode Settings

Follow these steps to view the Program Mode:

**NOTE: Do NOT change these settings.**

1. From any operation mode (Bagel Ready, Bagel Wait, Muffin Ready, Muffin Wait, Lunch Ready or Lunch Wait) open the Front Cover and press and hold the **PRGM** button for 3 seconds.
2. The following appears on the display:  

```
Program Muffin (Or Bagel Or Lunch)
Press Select
```
3. Press the **SELECT** button and use the **NEXT** or **PREV** buttons to scroll through the following categories (Refer to the *Universal Toaster Settings* section for more information on these categories):
  - Speed
  - Platen Mode (Default setting is Always On)
  - Units (F/C) (Default setting is F)
  - Platen Temp
  - IR Lower %
  - IR Upper %
4. When you reach the desired category, press the **Select** button **ONCE**. This causes the value to blink, indicating the value is in Edit mode.
5. Press the **PREV** or **NEXT** button while the value is blinking, to change the setting.
6. When you are finished viewing settings, press the **PRGM** button or wait 10 seconds and the unit will return to the Operation Mode (Bagel Ready, Bagel Wait, Muffin Ready, Muffin Wait, Lunch Ready or Lunch Wait).

**NOTE: The unit will exit the Program Mode after 10 seconds of inactivity.**

### ⚠ WARNING ⚠

**Do NOT press the NEXT or PREV buttons at this time. This may change the default settings and affect the normal operation of the unit!**

The Bagel and Muffin Program use the following three settings:

- Speed
- IR Lower%
- IR Upper %

The Lunch Program uses the following four settings:

- Speed
- Platen Temp
- IR Lower %
- IR Upper %

### Universal Toaster Settings

The following tables shows the recommended settings for the UTX-200L Universal Toaster:

#### LUNCH

Setting	Value
Bun Thickness Compression Control knob	3
Platen Temperature	570°F (299°C)
IR Percent Upper	60%
IR Percent Lower	0%
Lunch Speed (22 Seconds)	5720

#### MUFFIN

Setting	Value
IR Percent Upper	80%
IR Percent Lower	50%
Muffin toasting speed (95 seconds).	200

#### BAGEL

Setting	Value
IR Percent Upper	80%
IR Percent Lower	50%
Bagel toasting speed (55 seconds)	340

**NOTE: It is recommended that these settings remain unchanged.**

**OPERATION (continued)**

**UTX-200L Unit Status Mode**

This mode provides feedback on how the unit's systems are performing. No adjustments can be made in this mode. Also, the display will remain on the selected screen in this mode until you switch screens or exit Unit Status Mode.

Follow these steps to view the Unit Status mode.

1. From any operation mode (Bagel Ready, Bagel Wait, Muffin Ready, Muffin Wait, Lunch Ready or Lunch Wait), open the Front Cover and press and hold the **ADJUST** button for 3 seconds.
2. The following appears on the display in sequence (use the **NEXT** and **PREV** buttons to scroll through these items):
  - **Temp-Platen-Set Pt**
  - **Run Time**
  - **Blower Temp**  
(temperature of the air coming out of the blower)
  - **Controls Temp**  
(air temperature inside the electrical enclosure)
  - **Fan Speed % of Normal**  
L: (Left Fan), C: (Center Fan), R: (Right Fan)
  - **Speed-Motor-Set-Pt**
  - **Lower IR**  
(The set point current value appears on the top line. The actual current value appears on the lower line)
  - **Upper IR**  
(The set point current value appears on the top line. The actual current value appears on the lower line)
  - **Smart Kitchen Network Not Detected**
3. Press the **PRGM** button once. This exits the Unit Status Mode and returns to the current operation mode screen.

**Changing the Display Language**

Follow these steps to change the display language between English and Spanish:

1. At any time during power off (but connected to power), cool down, warm-up, or normal operation, press the **SELECT** button.
2. Press the **NEXT** button to select the desired language and then release the button.
3. After 3 seconds, the change is stored into memory.

**Purging Products from the Toaster**

**NOTE: The unit must be in a READY or WAIT mode in order to purge products.**

There are two ways to purge products from the unit:

1. **FACING FRONT OF UNIT:**  
With the unit in any READY or WAIT mode, open the Front Cover. Press and hold the **NEXT** arrow button until the product is purged from the unit (Figure 5).  
Once the product is purged, release the **NEXT** button and the unit will return to normal operating speed.

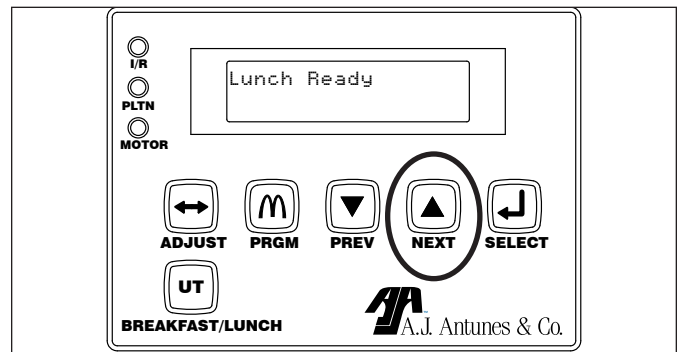

**Figure 5. Purging Products: Front of Unit**

2. **FACING REAR OF UNIT:**  
With the unit in a READY or WAIT mode, you can also press and hold BOTH **MUFFIN/BAGEL** selector buttons together to purge product from the unit. These buttons are located at the rear of the unit (Figure 6).

Once the product is purged, release both **MUFFIN/BAGEL** selector buttons.

These procedures temporarily speed up the unit to purge products out to the front of the toaster.

## OPERATION (continued)

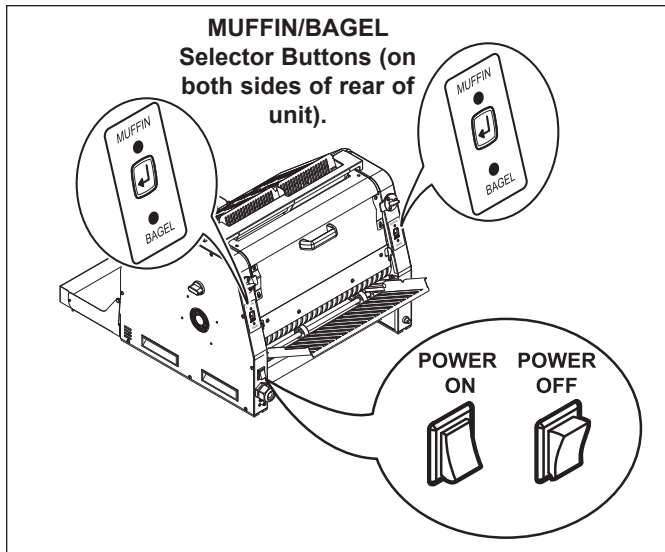

Figure 6. Purging Products: Rear of Unit

**NOTE:** Product is always purged out of the front of the Toaster using the NEXT button or the MUFFIN/BAGEL selector buttons. It is NOT possible to purge product backwards through the unit.

### Shutting down the UTX-200L

Follow these steps to shut down the toaster:

1. Turn the Power Switch off.
2. The unit enters cool down mode and displays OK to Clean. The fans continue to run. This cool down mode continues for 45 minutes and shuts the unit down automatically when complete.

#### ⚠ IMPORTANT ⚠

Do NOT unplug the power cord when the unit is in cool down mode. Wait for the 45-minute cool down period to complete before unplugging the power cord.

#### ⚠ WARNING ⚠

To avoid possible personal injury and/or damage to the unit, all inspections, tests, and repair of electrical equipment should be performed by QUALIFIED SERVICE PERSONNEL. The unit MUST be shut down and UNPLUGGED before performing any internal service, except when electrical tests are required. Use extreme care during electrical circuit tests. Live circuits will be exposed.

### Reset to Factory Defaults

Inadvertent changes to the settings of the UTX-200 could affect how the unit operates. If a fault message appears, it is recommended that you first attempt to restore the settings to the factory defaults. This will restore all settings and parameters to McDonald's corporate specifications.

**NOTE:** The UTX-200 should NOT be unplugged during normal operation or during the 45-minute cool down period.

Follow these steps to reset the Factory Defaults:

1. Turn the Power Switch off. The red light on the switch turns off.
2. Turn the Power Switch on.
3. Listen for the unit to click three times, then immediately press and hold the **PREV** and **NEXT** buttons until the display reads `Factory Defaults Set.`

**NOTE:** The display will then go blank.

4. Turn the Power Switch off and then back on.
5. Wait for the 20-second countdown to complete.

**NOTE:** The unit will then display `Muffin Wait.`

6. Preheat the unit and test for proper operation.

**NOTE:** If after resetting the Factory Defaults the unit continues to display a fault/error message, turn the power off and unplug the power cord. Wait a few seconds and then plug the power cord back in. Then repeat steps 2 through 6. If the unit still displays a fault/error message, immediately call your Authorized Service Agency for assistance.

**OPERATION (continued)**

**Adjusting the Upper and Lower I.R.**

If toasted muffins and/or bagels are too light and the toasting quality is at the darkest setting, you may need to increase the Upper and Lower I.R. percentages from their default settings.

**NOTE: The Muffin and Bagel modes must always have the same Upper and Lower I.R. settings.**

1. While in Muffin Ready mode, open the Front Cover and press and hold the **PRGM** button for 3 seconds to go into Program mode.

**NOTE: The unit will exit Program mode after 10 seconds of inactivity.**

2. The following appears on the display:

```
Program Muffin
Press Select
```

3. Press the **SELECT** button and then press the **NEXT** button once to display the Upper I.R. setting. It should read 80%.
4. Press the **SELECT** button once to go into Edit mode. The value should start blinking.
5. Press the **NEXT** button twice to increase the Upper I.R. setting to 84%.
6. Press the **SELECT** button to store the new Upper I.R. setting.
7. Press the **NEXT** button once to display the Lower I.R. setting. It should read 50%.
8. Press the **SELECT** button once to go into Edit mode. The value should start blinking.
9. Press the **NEXT** button twice to increase the Lower I.R. setting to 54%.
10. Press the **SELECT** button to store the new Lower I.R. setting.
11. Press the **PRGM** button to exit Program mode.
12. Press the Bagel Selector button on the rear of the toaster to select Bagel mode.
13. While in Bagel Ready mode, press and hold the **PRGM** button for 3 seconds to go into Program mode.
14. The following appears on the display:

```
Program Bagel
Press Select
```

15. Repeat steps 3 through 11 to adjust the Upper I.R. setting to 84% and the Lower I.R. setting to 54%.

16. Once outside of Program mode, press the **ADJUST** button (Figure 7).
17. Use the **PREV** and **NEXT** buttons to bring the toasting quality indicator into the center of the range (Figure 7).

**NOTE: Two bars will be lit when the adjustment is in the center (Figure 7).**

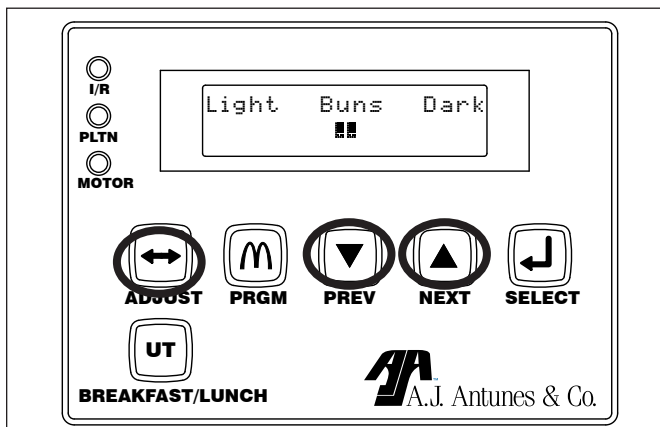

**Figure 7. Adjusting Toasting Quality**

18. Press the **PRGM** button when the adjustment is complete to return to Ready mode.
19. Close the Front Cover and allow the unit to warm up for 10 to 20 minutes.
20. Test one or two muffins and bagels to ensure the product is toasting with the desired quality.
21. If these settings do not give the desired results, you may use the same steps to increase or decrease the Upper and Lower I.R. settings, or you may use the **ADJUST** button to make the toasting quality lighter or darker.

**NOTE: If the unit is reset to the factory default, these new Upper and Lower I.R. settings will need to be re-entered.**

### MAINTENANCE

#### **⚠ WARNING ⚠**

The unit will remain hot to the touch while it is cooling down. Personal injury and burns may result from touching the unit before it is finished cooling down. Wear Heat Resistant Gloves!

#### **DAILY: Cleaning the Accessories, Release Sheet, and Vertical Conveyor Belt**

**NOTE: Do NOT wash accessories in the Power Soak machine.**

#### **CLEANING THE ACCESSORIES AND TOASTER**

1. Turn the Power Switch off. The red light on the switch turns off (if present).
2. The unit enters cool down mode and displays **OK to Clean**. The fans continue to run. This cool down mode continues for 45 minutes and shuts the unit down automatically when complete.

**NOTE: You do NOT need to wait for the count down to complete. Continue with the cleaning steps as soon as you see **OK to Clean**.**

3. Wearing Heat Resistant Gloves, remove the following items from the unit (refer to Figure 1):
  - Breakfast Chute (Rear of unit)
  - Bun Feeder (Top of unit)
  - Bun Buffer (Front of unit)
  - Unit Crumb Tray (Rear of unit)
  - Release Sheet Retainer Bar and Release Sheet (Top of unit)

#### **⚠ WARNING ⚠**

Do NOT wash any of the accessories in a Power Soak Machine or any other mechanical washer. Damage to the accessories may result. Wash all accessories by hand in the sink.

4. Set the Release Sheet Retainer Bar and the Release Sheet aside.
5. Wash the Breakfast Chute, Bun Feeder, Bun Buffer, and Crumb Tray in the three compartment sink.
6. Wipe down the outside of the toaster with a clean, sanitized towel dampened with **KAYQUAT II™ Sanitizer Solution (HCS)**.

#### **CLEANING THE RELEASE SHEET**

1. Remove the Release Sheet from the Release Sheet Retainer Bar and inspect both sides of the Release sheet.

**NOTE: Replace the Release Sheet if it is overly worn, creased, or torn.**

2. Lay the release sheet on a clean, flat, dry surface. Spray **EXCEED Glass and Multi-Purpose Cleaner (HCS)** on a clean, dry towel.
3. Wipe the Release Sheet firmly from top to bottom over its entire surface.
4. Immediately repeat this procedure with a clean, dry towel dampened with water.
5. Finally, wipe the entire Release Sheet with a clean towel dampened with **KAYQUAT II™ Sanitizer Solution (HCS)** and allow to air dry.
6. Turn the Release Sheet over and repeat Steps 2 through 5 on the reverse side.

#### **CLEANING THE VERTICAL CONVEYOR BELT**

**NOTE: Wear Heat Resistant Neoprene Gloves.**

1. Face the rear of the unit. Turn the two Back Panel Release Latches (Figure 8) to the vertical position and open the Back Panel.

#### **⚠ WARNING ⚠**

The Horizontal Conveyor Belt and the Vertical Conveyor Belt continue to turn during Cleaning mode. To stop the belts, press the **UT** button. To temporarily advance the belts during cleaning, press and hold both **MUFFIN/BAGEL** buttons as desired. Release to stop the belts again. Be sure to press **UT** again to resume.

**MAINTENANCE (continued)**

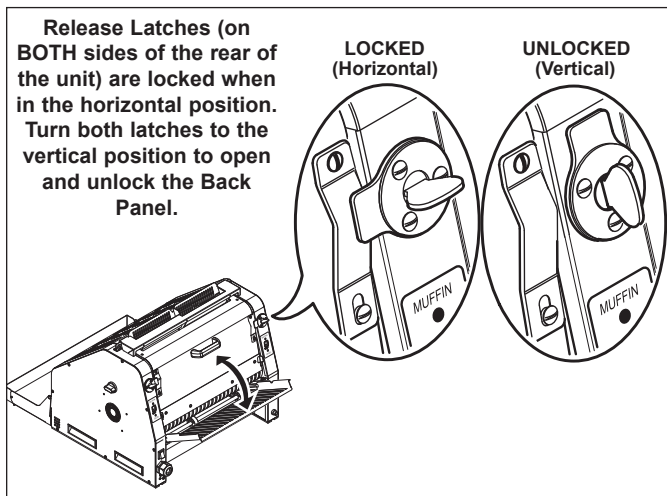

**Figure 8. Back Panel Release Latches**

- Apply **McD<sup>®</sup> Heavy Duty Degreaser (HCS)** on a *clean, sanitizer soaked grill cloth*. Wipe the exposed part of the Conveyor Belt with the grill cloth from side to side. Use the master links for reference (Figure 9).

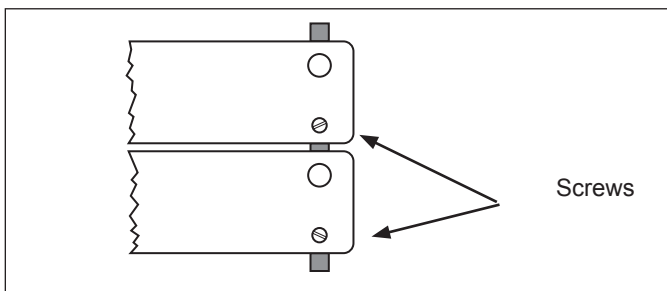

**Figure 9. Master Links**

- Press and hold both **MUFFIN/BAGEL** selector buttons on the back of the unit (Figure 6) until to uncleaned portion of the belt is exposed. Repeat Step 2 on the uncleaned portion of the belt.
- Rinse/wipe the vertical Conveyor Belt with the grain (Side to side) using **KAYQUAT II™ Sanitizer Solution (HCS)** and allow to air dry.

**NOTE: Do NOT leave the Back Panel open any longer than it takes to complete these cleaning procedures. Refer to the cleaning label located on the back of the unit.**

- Follow this step only if the vertical conveyor belt does not become clean after steps 2 through 4:
  - Open a packet of **McD Hi-Temp Grill Cleaner (HCS)**. Empty the contents on an entrée base.

- Use a no-scratch pad to spread a light coating of grill cleaner over the entire exposed part of the conveyor belt.
  - Lightly scrub the belt with the non-scratch pad until clean.
- Install the Release Sheet onto the Release Sheet Retainer Bar and install onto unit.

**NOTE: Rotate the Release Sheet from side to side daily to extend the life of the Release Sheet.**

- Reattach all accessories to the unit (Figure 1).

**NOTE: Check the Release Sheet to make sure it is draped properly over the Platen.**

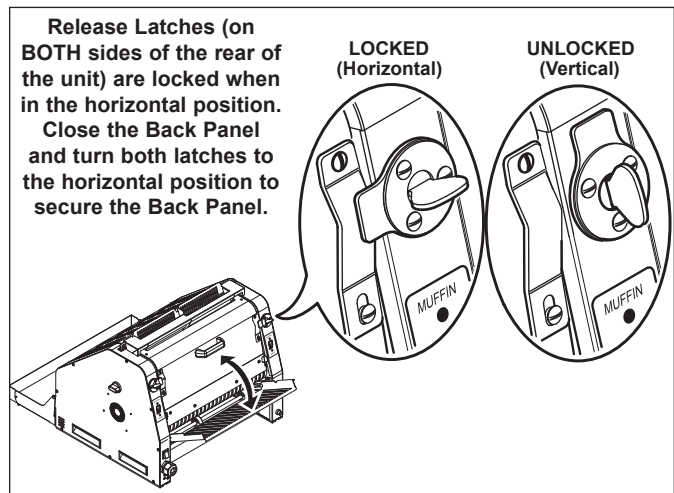

**Figure 10. Back Panel Release Latches**

- Verify that the Bun Thickness Compression Control knob is set to 3 (Figure 2).
- Close the Back Panel and lock the Back Panel Release Latches (Figure 10).
- Place the toaster back into operation.

**WEEKLY & SEMI ANNUALLY: Clean Cooling Fans**

Refer to the document **UTX-200 Cooling Fan and Blower Motor Cleaning Instructions (P/N 1011059)** and follow the directions in that document to clean the cooling fans, blower motor, and electrical compartment. This document provides Weekly & Semi-annual tasks.

**NOTE: It is very important to keep the cooling fans, blower motor, and electrical compartment clean and in top operational mode. Do not ignore these cleaning steps.**

## TROUBLESHOOTING

### ⚠ CAUTION ⚠

To avoid possible personal injury and/or damage to the unit, all inspections, tests, and repair of electrical equipment should be performed by **QUALIFIED SERVICE PERSONNEL**. The unit **MUST** be shut down and UNPLUGGED before servicing, except when electrical tests are required. Use extreme care during electrical circuit tests. Live circuits will be exposed.

Problem	Possible Cause	Corrective Action
No Display and/or no light on the Power Switch.	Unit not plugged in.	Plug the power cord into the appropriate outlet.
	Hi-Limit thermostat is tripped.	Reset Hi-Limit.
	Circuit Breaker tripped.	Reset Circuit Breaker.
	Power Cord and/or plug are damaged.	Contact your maintenance person or Authorized Service Agency.
	Inoperable Power Switch.	
Unit displays one of the following messages:  Upper IR Heater Fault or Lower IR Heater Fault	Failed heater.	Allow about 10 minutes for the toaster to self adjust.
	Wire disconnected in IR circuit.	
	Control wires to the Solid State Relay are disconnected.	Adjust the toast quality setting. Refer to the Operation section of this manual.
	The Solid State Relay has failed.	
Unit displays the following message:  Conveyor Motor Fault	Retainer Ring not locked on plug.	Plug power cord in tightly and lock the Retainer Ring.
	Product is getting stuck in the conveyor system or the conveyor system is jammed.	Check and clear the vertical and horizontal conveyors for any stuck product. Refer to the Operation and Maintenance sections of this manual for proper compression settings and cleaning procedures.
Unit displays the following message:  SSR Failure - System Stopped	The motor controller circuit has failed or is inoperable.	Call your Authorized Service Agency for service.
	A relay has failed preventing proper heater control.	The toaster cannot be operated with this kind of failure. Contact your Authorized Service Agency for service.
Unit displays the following message:  Platen Temp Fault	A heater or relay in the Platen circuit has failed.	The conveyors will continually adjust speed to compensate for low Platen temperature. If the Platen cannot maintain 525°F (274°C), the unit will signal an error and stop operating. If this happens, contact your Authorized Service Agency for service.

**TROUBLESHOOTING**

<b>Problem</b>	<b>Possible Cause</b>	<b>Corrective Action</b>
Unit displays the following message: Platen Fail  NOTE: A Thermocouple which has become grounded will cause erratic controller behavior.	The Thermocouple in the Platen circuit has failed.	The toaster cannot be operated in Lunch mode with this type of failure. Contact your Authorized Service Agency for service.
Unit displays the following message: Platen SSR Fail	A control relay has a short or the Thermocouple is not pushed into Platen correctly.	The toaster will open the C1 contactor, disabling the toaster. Contact your Authorized Service Agency for service.
The overtemp thermocouple temperature is greater than 250°F (121°C) but less than 350°F (177°C). Unit displays the following message: Main Blower Fault	There is a problem with the main convection blower.	Unit will operate normally but this issue should be addressed by an Authorized Service Agency.
The overtemp thermocouple temperature is greater than 350°F or an open thermocouple condition exists. Unit displays the following message: IR Sensor Fail	There is a problem with the main convection blower.	The toaster will shut down. Allow the toaster to cool and the restart. If this condition persists, contact your Authorized Service Agency for service.
Cooling fan speed error. Unit displays one or more of the following messages: Left Fan Fault Ctrl Hsg Fan Fault Right Fan Fault	Cooling fan failure.	The toaster will operate normally until the compartment ambient temperature exceeds 150°F (66°C). At this point the toaster will shut down. Contact your Authorized Service Agency for service.
Product sticking in vertical conveyor or product not toasted properly.	Dirty Release Sheet.	Clean the Release Sheet according to the Maintenance section of this manual.
	Bun Thickness Compression Control knob is set incorrectly.	Set the Bun Thickness Compression Control knob is set to 3.
	Product inserted incorrectly into vertical conveyor.	Refer to the Operation section in this manual for proper operation procedures. Also refer to the product labels on the unit.
	Unit may not be in the proper operation mode.	When toasting Muffins or Bagels, the unit must be in Breakfast Mode. When toasting Buns, the unit must be in Lunch Mode. Refer to the Operation section of this manual.
Unit displays the following message: WARNING! Power Fault Unplug now!!!	Contactors and control relay failures. Unit has detected IR current or rising Platen temperature with the power off.	Immediately unplug the power cord and call your Authorized Service Agency for service. The unit must not be operated with this kind of failure.

### REPLACEMENT PARTS

#### ⚠ CAUTION ⚠

To avoid possible personal injury and/or damage to the unit, all inspections, tests, and repair of electrical equipment should be performed by **QUALIFIED SERVICE PERSONNEL**. The unit **MUST** be shut down and UNPLUGGED before servicing, except when electrical tests are required. Use extreme care during electrical circuit tests. Live circuits will be exposed.

#### UTX-200L Components

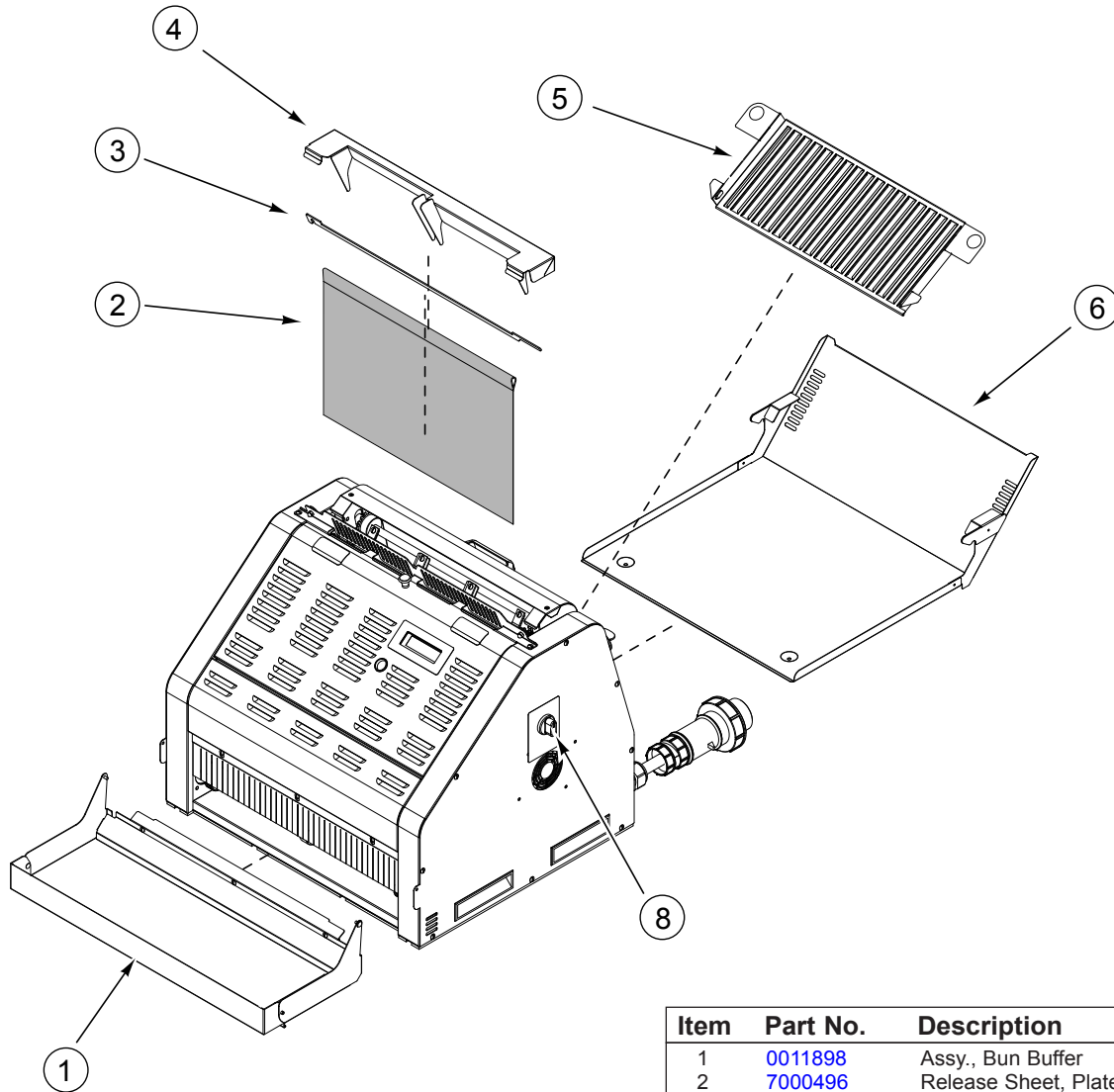

For additional replacement parts, contact your Authorized Service Agency.

You may also contact the factory at 1-877-392-7854 (North America only), or 630-784-1000.

Item	Part No.	Description	Qty.
1	0011898	Assy., Bun Buffer	1
2	7000496	Release Sheet, Platen	1
3*	7000495	Release Sheet, Platen (package of 10)	1
3	0504310	Bar, Holding	1
4	0021500	Bun Feeder Weldment	1
5	0504371	Breakfast Chute	1
6	0021497	Crumb Tray Weldment	1
7	0700698	Power Cord Assy., 3 Ph 250V, 30A (Mfg. No. 9210805 only)	1
	0700711	Power Cord Assy, 3 Ph, Twist Lock L15-30P (Mfg. No. 9210806 only)	1
8	2100253	Knob, 1/4" Shaft, Push-On	2
* Not Shown			



**A.J. Antunes & Co.**  
We exist to make our customers successful.

---

**A.J. Antunes & Co.**  
Headquarters/Manufacturing  
Carol Stream, Illinois 60188 USA  
Phone: (630) 784-1000  
Toll Free: (800) 253-2991  
Fax: (630) 784-1650

**Antunes Equipment**  
Manufacturing (Suzhou) Ltd.,  
Suzhou, Jiangsu, China 215011  
Phone: 86-512-6841-3637  
Toll Free: 400-0-7878-22  
Fax: 86-512-6841-3907

**[www.ajantunes.com](http://www.ajantunes.com)**