

MANUFACTURING

NUMBERS:

9700460
9700462
9700470
9700472

vizion™

by A.J. Antunes & Co.

WATER FILTRATION SYSTEM

UFL-420/440 Series



Tested and Certified
by NSF International against
NSF/ANSI Standard 53 for
cyst reduction.

P/N 1010864 Rev. C 03/12



Owner's Manual

TABLE OF CONTENTS

Owner Information	2	LED Display	12
General	2	Operation	12
Warranty Information	2	Starting the System	12
Important Safety Information	3	Programming Timer During Startup.....	13
Service/Technical Assistance	3	Setting the Flush Interval (Fi).....	13
Electrical Cord & Plug Configurations	5	Setting Flush Duration (FD).....	13
Electrical Ratings.....	5	Manual Flushing	14
Specifications	5	Checking the Timer Program.....	15
Dimensions.....	5	Changing the Cartridges	15
Performance Data Sheet	7	Maintenance	15
Filter Cartridge Capacities	7	System Sanitization	15
System Capacities.....	7	Troubleshooting	16
Performance Claims for Percent Reduction	7	Wiring Diagram	17
Installation	8	Replacement Parts UFL-420/440	19
Unpacking.....	8	LIMITED WARRANTY	Back Cover
Equipment Setup.....	8		
Locating and Mounting the System.....	9		
Filtration Process.....	12		

OWNER INFORMATION

General

Antunes Filtration Technologies, Division of A.J. Antunes & Co., has partnered with companies from around the globe to produce the UFL-Series water filtration systems. The UFL-Series removes bacteria and provides a substantial reduction of viruses that can enter a typical water supply. This patented technology is now available to you, sized for your particular application. All filter configurations utilize NeoH capillary membranes, providing the latest innovation in reusable surface filtration technology.

This manual provides the safety, installation and operating procedures for the UFL-Series water filtration systems. We recommend that all information contained in this manual be read prior to installing and operating the unit.

Your UFL-Series unit is manufactured from the finest materials available and is assembled to AFT's strict quality standards. This unit has been tested at the factory to ensure dependable trouble-free operation.

Warranty Information

Please read the full text of the Limited Warranty in this manual.

If the unit arrives damaged, contact the carrier immediately and file a damage claim with them. Save all packing materials when filing a claim. Freight damage claims are the responsibility of the purchaser and are not covered under warranty.

The warranty **does not** extend to:

- Damages caused in shipment or damage as result of improper use.
- Installation of electrical service.
- Normal maintenance as outlined in this manual.
- Malfunction resulting from improper maintenance.
- Damage from moisture leaking into electrical components.
- Normal maintenance as outlined in this manual.
- Damage from tampering with, removal of, or changing any preset control or safety device.

IMPORTANT! Keep these instructions for future reference. If the unit changes ownership, be sure this manual accompanies the equipment.

OWNER INFORMATION (continued)

Service/Technical Assistance

If you experience any problems with the installation or operation of your unit, contact Antunes Filtration Technologies at **1-630-784-1000**, or toll free in the United States at **1-800-253-2991**.

Fill in the information in the next column and have it handy when calling for assistance. The serial number is on the specification plate located on the unit.

Purchased From: _____

Date of Purchase: _____

Model No.: _____

Serial No.: _____

Mfg. No.: _____

IMPORTANT

A.J. Antunes and Company reserves the right to change specifications and product design without notice. Such revisions do not entitle the buyer to corresponding changes, improvements, additions or replacements for previously purchased equipment.

IMPORTANT SAFETY INFORMATION

Throughout this manual, you will find the following safety words and symbols that signify important safety issues with regards to operating or maintaining the unit.

In addition to the warnings and cautions in this manual, use the following guidelines for safe operation of the unit.



GENERAL WARNING. Indicates information important to the proper operation of the equipment. Failure to observe may result in damage to the equipment and/or severe bodily injury or death.



ELECTRICAL WARNING. Indicates information relating to possible shock hazard. Failure to observe may result in damage to the equipment and/or severe bodily injury or death.



GENERAL CAUTION. Indicates information important to the proper operation of the equipment. Failure to observe may result in damage to the equipment.

- Read all instructions before using equipment.
- For your safety, the equipment is furnished with a properly grounded cord connector. Do not attempt to defeat the grounded connector.
- Install or locate the equipment only for its intended use as described in this manual. Do not use corrosive chemicals in this equipment.
- Do not operate this equipment if it has a damaged cord or plug; if it is not working properly, or if it has been damaged or dropped.
- This equipment should be serviced by qualified personnel only. Contact Antunes Filtration Technologies for repair.
- Do not immerse cord or plug in water.
- Keep cord away from heated surfaces.

IMPORTANT SAFETY INFORMATION (continued)

The following warnings and cautions appear throughout this manual and should be carefully observed.

- Turn the unit off and disconnect the power source before performing any service or maintenance on the unit.
- The equipment should be grounded according to local electrical codes to prevent the possibility of electrical shock. It requires a grounded receptacle with separate electrical lines, protected by fuses or circuit breaker of the proper rating.
- All electrical connections must be in accordance with local electrical codes and any other applicable codes.
- **WARNING ELECTRICAL SHOCK HAZARD. FAILURE TO FOLLOW THESE INSTRUCTIONS COULD RESULT IN SERIOUS INJURY OR DEATH.**
 - Electrical ground is required on this appliance.
 - Do not modify the power supply cord plug. If it does not fit the outlet, have a proper outlet installed by a qualified electrician.



- Do not use an extension cord with this appliance.
- Check with a qualified electrician if you are in doubt as to whether the appliance is properly grounded.
- If the supply cord is damaged, it must be replaced by the manufacturer or its service agent or a similarly qualified person.
- This equipment is to be installed to comply with the local plumbing code and any other applicable code.
- Water pressure must not exceed the membrane burst pressure of 100 psig (690 kPa). To reduce water pressure, install a water pressure regulator and set water pressure to suit application. Note that trans membrane pressure (inlet water pressure minus the permeate water pressure) must be .5 - 2.5 bar (7 - 36 psi).

SPECIFICATIONS

Electrical Ratings

Model & Mfg. No.	Voltage	Watts	Amps	Hertz
UFL-420 9700460	120	10	.085	50/60
UFL-420 9700462	230	10	.04	50/60
UFL-440 9700470	120	10	.085	50/60
UFL-440 9700472	230	10	.04	50/60

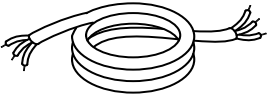
Electrical Cord & Plug Configurations

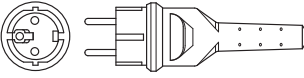
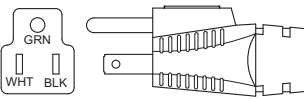
Letter Code*	Description	Configuration
C	Commercial Cord	
H	Harmonized Cord	
(H)C**	CEE 7/7, 16 Amp., 250 VAC (Assembly Only).	
(C)F***	5-15P, 15 Amp., 120 VAC., Non – Locking (Assembly Only).	

* Used in Model Designation

** Indicates that the Plug comes with a Harmonized Cord

*** Indicates that the Plug comes with a Commercial Cord

⚠ CAUTION ⚠

All electrical connections must be in accordance with local electrical codes and any other applicable codes.

Dimensions

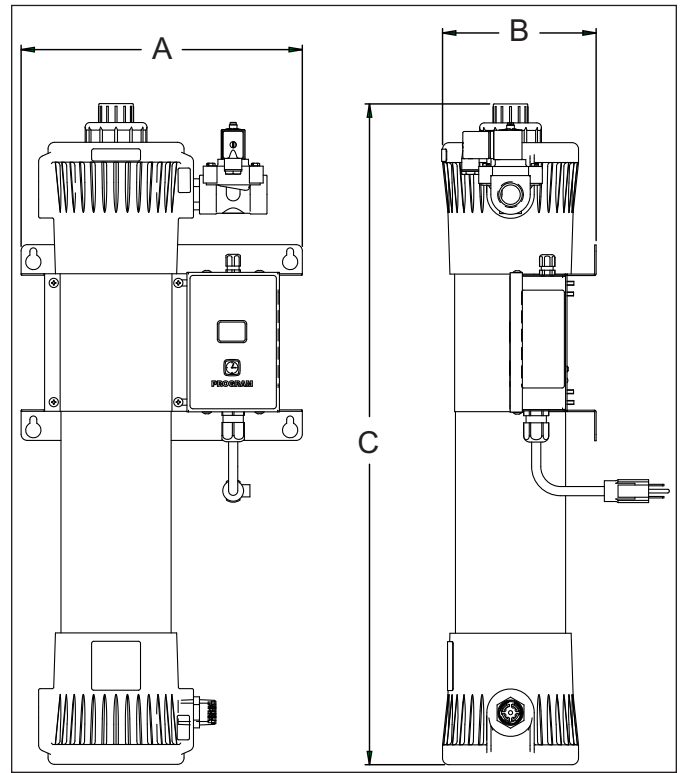

Figure 1. Dimensions

UFL-420

A Width	B Depth	C Height	Operating Weight (w/water) (lbs)	Min. Clearance for Cartridge Change above or below unit (inches)
11.5 in	6 in	28 in	28 lbs.	19 in

UFL-440

A Width	B Depth	C Height	Operating Weight (w/water) (lbs)	Min. Clearance for Cartridge Change above or below unit (inches)
11.5 in	6 in	47 in	42 lbs.	38 in

REPLACEMENT CARTRIDGE

UFL-420	L-420 (P/N 7000411)
UFL-440	L-440 (P/N 7000412)

SPECIFICATIONS (continued)

Components

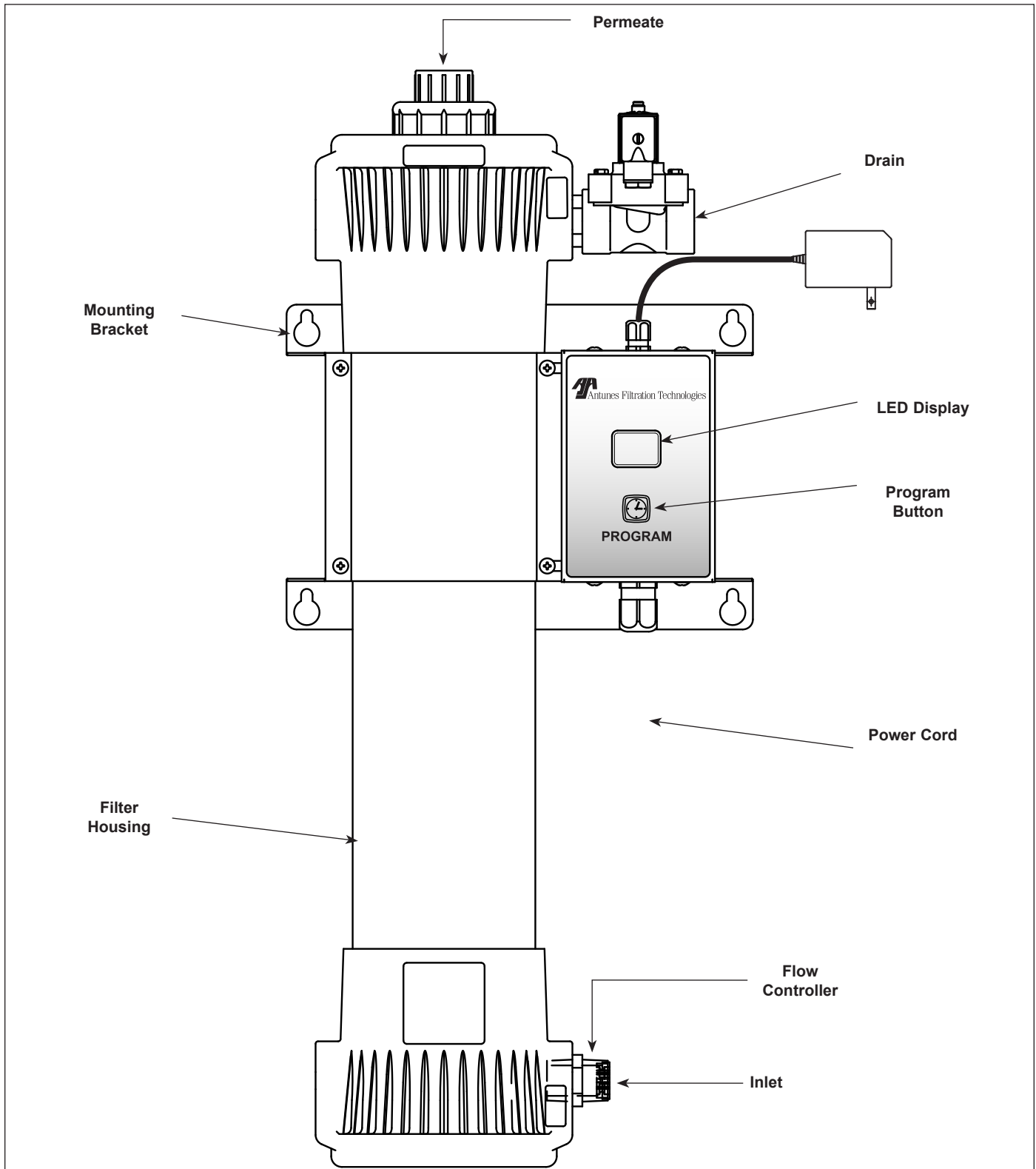

Figure 2. Components

PERFORMANCE DATA SHEET

Filter Cartridge Capacities

Maximum Operating Pressure	100 psig (690 kPa)
Maximum Operating Temp.	104°F (40°C)
Trans Membrane Pressure	0.5-2.5 Bar (7-36 psi)
pH Range	3-10
MWCO	100 kD



Tested and Certified
by NSF International
against NSF/ANSI Standard
53 for cyst reduction.

System Capacities

Series	UFL-420	UFL-440
Liters per hour	1045	2089
Liters per minute	17	35
Gallons per hour	276	552
Gallons per minute	4.6	9.2

This system has been tested according to NSF/ANSI Standard 53 for reduction of the substances listed below. The concentration of the indicated substances in water entering the system was reduced to a concentration less than or equal to the permissible limit for water leaving the system, as specified in NSF/ANSI 53. While testing was performed under standard laboratory conditions, actual performance may vary.

Performance Claims for Percent Reduction

Substance	Influent Challenge Concentration	Reduction Requirement
cyst ²	minimum 50,000/L	99.95%

²based on the use of microspheres or *Cryptosporium parvum* oocysts

INSTALLATION

Unpacking

1. Remove the system and all packing materials from the shipping carton.
2. Remove all packing materials and protective coverings from the system
3. Remove the information packet. To prevent any delay in obtaining warranty coverage, fill out and mail the warranty card.

NOTE: If any parts are damaged, contact Antunes Filtration Technologies IMMEDIATELY at 1-800-253-2991 or 1-630-784-1000.

Equipment Setup

GENERAL

When placing the unit into service, pay attention to the following guidelines:

- Do not immerse cord or plug in water.
- Keep cord away from heated surfaces.

ELECTRICAL

Ensure that the line voltage corresponds to the stated voltage on the units specification label. Make sure that the plug on the power cord from the system and the outlet match. For proper operation, and to ensure the highest quality water from the system, make sure that the system is not connected to a switched electrical outlet.

PLUMBING

NOTE: This unit is designed to use tap water not to exceed 100°F (38°C) or 100 psig (690 kPa).

The UFL-420 and UFL-440 systems use the following connections (Figure 1):

- | | |
|----------------------------|----------|
| • Water Inlet | 3/4" NPT |
| • Permeate (Product Water) | 3/4" NPT |
| • Drain | 3/4" NPT |

When making a plumbing connection to the system, remember to use a back-up wrench on the supporting plumbing. Always use a good quality, approved pipe sealant or thread seal tape on pipe threads. Be careful not to get the pipe sealant inside the pipe when making the connections.

DO NOT over tighten the connections. It is recommended that plastic fittings be used when connecting to the plastic connections of the system. This will reduce the possibility of cracking the connections due to over-tightening.

If soldered plumbing is used, do not apply heat to, or near, the filtration system. The use of union (O-ring seal) connections is highly recommended for ease of installation and future servicing.

SUGGESTED TOOLS AND SUPPLIES FOR INSTALLATION

The following tools and supplies are suggested to make the installation easier:

- | | |
|---------------------|---------------------------------------|
| • Screwdriver | • Adjustable wrenches |
| • Drill with bits | • Pipe wrenches |
| • Strap wrench | • Level |
| (up to 6" diameter) | • Pipe dope or thread seal tape |
| • Tape measure | |
| • Two gallon bucket | • Fresh 5 1/4% liquid chlorine bleach |

⚠ CAUTION ⚠

This equipment is to be installed to comply with the basic plumbing code of the Building Officials and Code Administrators, Inc. (BOCA) and the Food Service Sanitation Manual of the Food and Drug Administration (FDA).

⚠ CAUTION ⚠

Water pressure must not exceed a membrane burst pressure of 100 psig (690 kPa). To reduce water pressure, install a water pressure regulator and set water pressure to suit application. Note that the trans membrane pressure must be 0.5 - 2.5 bar (7 - 36 psi).

FLOW REGULATOR ASSEMBLY

Your filtration system uses a water Flow Regulator Assembly that controls the flow of water into the unit. This assembly consists of a white threaded male connector and a color-coded Flow Regulator (Figure 3). The unit **MUST** be operated with the appropriate Flow Regulator Assembly.

- UFL-420 Units: Use a **GREEN** and WHITE Flow Regulator Assembly (5 gallons per minute).
- UFL-440 Units: Use a **BLACK** and WHITE Flow Regulator Assembly (10 gallons per minute).

⚠ CAUTION ⚠

Flow Regulator Assemblies are NOT interchangeable. Operating the system with the wrong Flow Regulator or without a Flow Regulator can damage the system, cause personal injury, and will void the warranty!

INSTALLATION (continued)

Locating and Mounting the System

Consider these points before mounting the system:

- Note the location of the water supply, drain, and an appropriate electrical outlet when choosing a mounting location.
- Remember to allow for access to the timer/ programmer controls.
- Do not mount the system above any electrical equipment, or items that may be damaged if they get wet.
- Install the system in a location that will allow for future service access. Cartridge replacement will be either through the top or bottom of the housing.

NOTE: Be sure to allow access to both the top and bottom of the housing.

- Mount the system on a wall using appropriate mounting hardware.
- Remember to consider the operating weight of the system when choosing mounting hardware. Depending on the type of wall the system is being mounted to, wall reinforcement may be necessary.

Mount the filtration unit using the Mounting Bracket (Figure 2) using 1/4" by 1" bolts or bolts of the metric equivalent.

INLET WATER PLUMBING

It is recommended that the inlet water plumbing line be 3/4" NPT or larger. A shutoff valve (not supplied) should be installed in the line leading to the system. The valve should be mounted close to the system inlet and sized properly for the inlet plumbing line.

It is also recommended that a "T" or Cross Fitting (with cap or plug) be installed between the inlet valve and the system Inlet. This fitting can be used for draining and sanitizing the system and downstream plumbing.

The system should only be connected to the cold water line.

To ensure that the highest quality water is produced from the system, the plumbing leading to the filter system must be flushed clear of all debris before the system is hooked up. Before making the connection to the inlet of the filter system, hold a bucket or other container at the inlet water line and slowly open the inlet water valved. Allow the pipe to flush until all debris is removed.

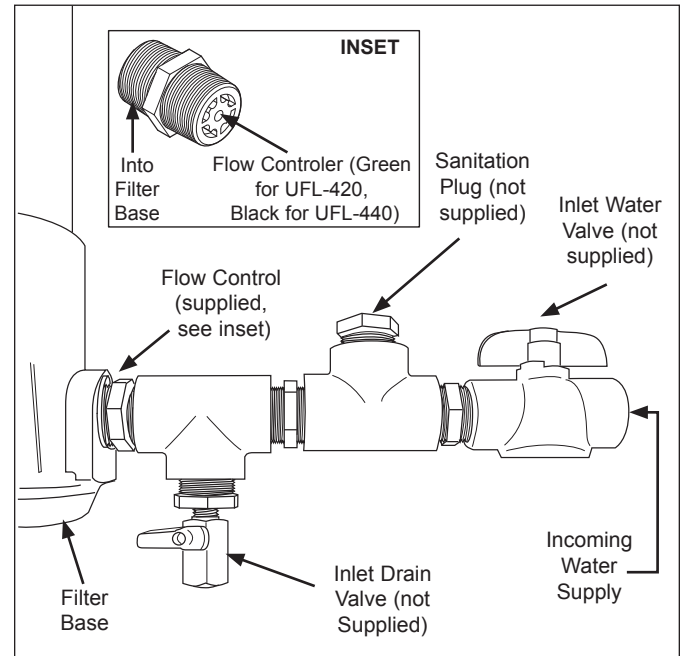

Figure 3. Inlet Water Plumbing

PERMEATE LINE PLUMBING

To ensure the highest quality and safest water, it is recommended that a check valve (to prevent backflow) be installed in the water line after the permeate connection. This will help prevent possible contamination of the filter system due to other equipment downstream. The check valve (not supplied) should be mounted close to the system outlet, and sized properly for the plumbing line. Check with local codes for the proper specification.

A shutoff valve (not supplied) should be installed in the filtered water line leading from the system. The valve should be mounted close to the system outlet and sized

INSTALLATION (continued)

properly for the plumbing line. This valve will allow for easier servicing and future cartridge change out.

DRAIN LINE PLUMBING

The drain line is used to flush away the particle buildup when cleaning the filter. The drain line must be able to support the flow rate when the system flushes. The flow rate from the flush depends on the inlet water pressure, inlet pipe size, and system selected. It is recommended that the drain line be as large as, or larger than, the inlet plumbing line. The drain line should be as short as possible, sloping downward without kinks or loops. Be sure that the drain used is not blocked or restricted.

The filter system must be protected from possible back contamination by the installation of an air gap between the drain connection of the system and the drain (Figure 4). This gap in the line, with no physical contact between the system and sewer, prevents contamination of the system in the event of a backed-up sewer.

NOTE: Make sure that the end of the drain line is positioned and secured at least 2 inches above the drain so that the water flow is directed into the drain, without splashing.

INSTALL THE CARTRIDGE

Install the cartridge into the housing by following the instructions on page 15 in the Changing the Cartridges area of the Maintenance section in this manual. Make sure that all O-rings are lubricated with a food-grade silicone lubricate before assembling

FLUSHING THE SYSTEM

To ensure that the highest quality water is produced from the system, the plumbing leading from the filter system must be flushed clear of all debris after the system is hooked up. After making the connection to the outlet of the filter system, open a faucet or tap closest to the filter system, then slowly open the inlet water valve. Allow the pipe to flush until all debris is removed.

The unit also must be flushed to remove air and the shipping/storage solution. For maximum quality, the permeate water produced during the flushing procedure must be discarded. Direct this permeate water to drain.



Ingesting the protective solution may cause irritation of the gastrointestinal tract, colic, diarrhea, or other similar symptoms

1. Plug the power cord into the appropriate electrical outlet. The unit will power on and the LED display will display the following for about two seconds each:

- 8.8
- F0 followed by its time settings in seconds
- F1 and its time setting in minutes or hours.

The F and F sequence repeats for about 20 seconds after which the switches to Flush Mode (FL) before returning to the Flush Interval Mode (F). The time setting for F1 will be displayed and the decimal point will flash in one second intervals.

2. Open the tap or faucet closest downstream to the filter system.
3. Slowly open the inlet water valve and allow water to enter the system.
4. Press and hold the Program button. After 6-7 seconds, the drain valve will open and F1 will appear on the display.
5. Continue holding the Program button down for at least 60 seconds to keep the drain valve open. This flushes air out of the center of the hollow fibers. The drain will remain open as long as the Program button is pressed. Check to make sure that the drain water is directed into the drain without splashing.
6. Release the Program button. This closes the drain valve. Water should continue to flow through the system and out of the open tap. Allow water to flow out of the tap for at least 15 minutes at maximum flow rate.
7. Close the tap and let the system stand without water flow for 15 minutes to allow any trapped air to come out of the hollow fibers. Check for leaks at all fittings.
8. After 15 minutes without water flow, open the tap for 5 minutes to allow any trapped air to be flushed out. Close the tap.
9. Once again, press and hold the Program button for at least 60 seconds to flush out any remaining air from the system.
10. Release the Program button. Flushing is complete.

INSTALLATION (continued)

SANITIZING THE SYSTEM AND LINES

The plumbing must be sanitized to eliminate possible contamination that may have occurred during the installation process. Chlorine bleach can be used to sanitize the plumbing. The amount of bleach to use depends on the system installed and the amount of plumbing downstream of the filter system. Generally, one ounce (30 ml) of bleach will be sufficient to sanitize the system.

1. Make sure that the system has been flushed of air and debris as described in the Flushing and Starting up the System section of this manual.
2. Open the tap closest downstream to the filter system.
3. Close the inlet water valve and allow the system to depressurize.
4. Place a bucket under the "T" or cross fitting at the inlet connection to the system. Open the inlet drain valve or unscrew the cap to drain the system.
5. Press and hold the Program button to help drain the system.

6. When the water flow out of the inlet fitting stops, close the inlet drain valve and pour the liquid bleach into the inlet connection fitting. Be careful not to spill bleach onto clothing or skin. You may want to add the bleach using a cup. Reattach the cap on the fitting.
6. Slowly open the inlet water valve and allow water to flow out of the tap until the smell of bleach is present.
7. Close the tap and let the system stand with no water flow for at least 15 minutes to allow the bleach to sanitize the pipes.
8. After 15 minutes without water flow, open the tap and flush until the presence of bleach is gone. All other taps should be opened to flush any bleach from the plumbing. Close the taps.
9. Press and hold the Program button for at least 60 seconds to complete the flushing process.
10. Sanitation is complete.

Program the timer following the procedure outlined in the Operation section of this manual.

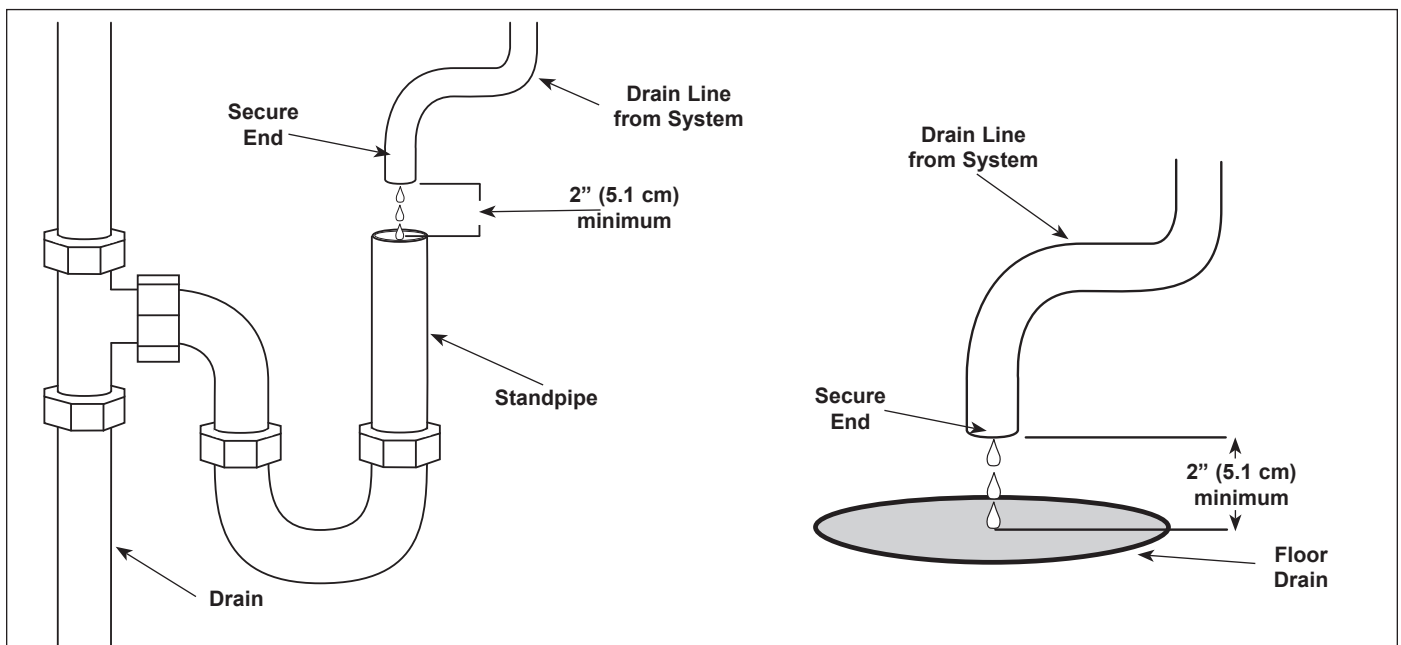

Figure 4. Proper Draining

OPERATION

Filtration Process

Water filtration in the UFL Series is accomplished using two modes:

- Flush Interval (F_I on the LED display)
- Flush Duration (F_D on LED display).

During the Flush Interval mode, water enters the inlet and flows through the filter element before exiting the Permeate outlet as usable product water. After a certain period of time, depending upon water quality, the filter has to be cleaned. This is accomplished through the Flush Duration Mode. During this mode, the drain valve opens and flushes the membrane to remove debris collected inside the membrane walls.

NOTE: Both the Flush Interval Mode and the Flush Duration Mode can be automated by programming the timer. During the Flush Interval Mode, the valve is not powered in order to keep water filtering during a power outage.

LED Display

F_I - Flush Interval Mode is the time between flushings and is displayed in minutes or hours.

F_D - Flush Duration Mode is the amount of time used to flush and remove debris from filter cartridge and is displayed in seconds.

FL - Manual Flush Mode operation, solenoid is manually activated by the user.

Starting the System

Power up the unit.

The LED read-out displays the following for about two seconds each:

1. 8.8
2. F_D followed by its time settings in seconds.
3. F_I and its time setting, in minutes or hours.

The F_D and F_I sequence repeats for 30 seconds after which, the unit automatically returns to the Flush Interval Mode (F_I). The time setting for F_I will be displayed and the decimal point will flash in one second intervals.

NOTE: The timer can be programmed immediately after start-up or while in Flush Interval Mode.



Figure 5. LED Display, Front Panel

OPERATION (continued)

Programming Timer During Startup

NOTE: Once the unit is powered up, the LED display cycles through the default or current settings: Flush Duration (Fd) and its setting will be followed by Flush Interval (Fi) and its settings. At any time during this sequence, which lasts approximately 30 seconds the unit can be programmed.

Setting the Flush Interval (Fi)

1. When Fi (Figure 5) is displayed, press and release the Program button to view current setting .
2. To make a change, press and hold the Program button to scroll through settings - release the button at desired setting (Figure 5).
3. The unit automatically returns to the Flush Interval Mode if the Program button is not pressed within 10 seconds..

NOTE: Fi times are displayed in ten minute intervals, after fifty minutes they are displayed in hours (Table A).

Setting Flush Duration (FD)

2. When Fd is displayed, press and release the Program button to view current setting (Figure 8).
3. To make a change, press and hold the Program button to scroll through settings - release the button at desired setting (Figure 9).
4. The unit automatically returns to the Flush Interval Mode if the Program button is not pressed within 10 seconds.

NOTE: Fd times are displayed in 5 second intervals up to 60 seconds (Table A).

Fi - Flush Interval Mode	Fd - Flush Duration Mode
1- 10 minutes	5 5 seconds
5- 50 Minutes	10 10 seconds
01 1 Hour	15 15 Seconds
12 12 Hours	30 30 Seconds
24 24 hours	60 60 Seconds

Table A. LED Display Settings

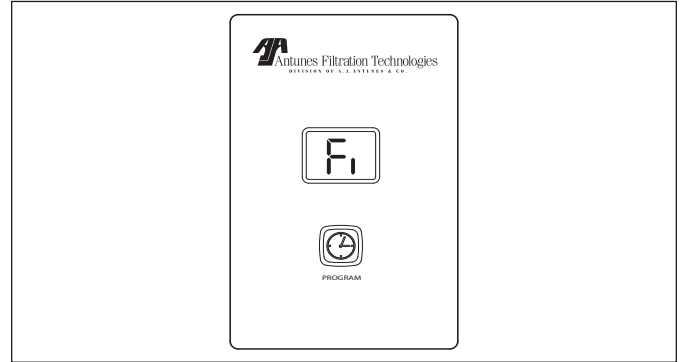

Figure 6. LED Display for Flush Interval Mode



Figure 7. Time Setting Fi Mode (22 Hours)

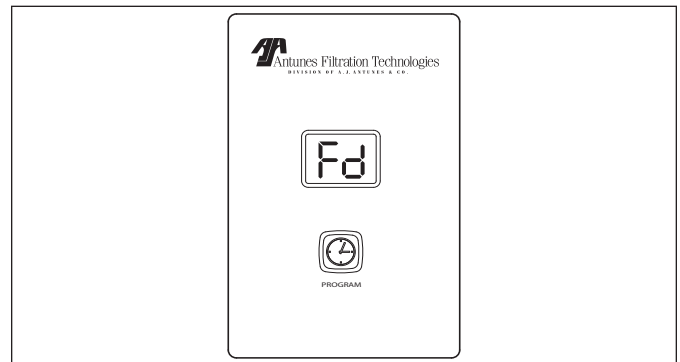

Figure 8. LED Display for Flush Duration Mode

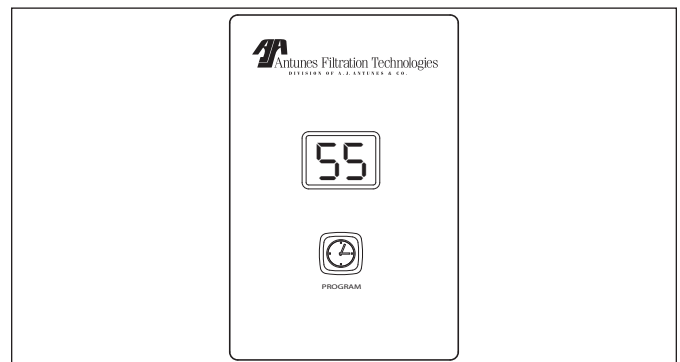

Figure 9. Time Setting Fd Mode (55 Seconds)

OPERATION (continued)

Programming Timer While Unit is in Flush Interval (Fi) Mode

TO SET Fi - FLUSH INTERVAL MODE

NOTE: After power-up and cycling - Fi time setting displays a flashing decimal point.

1. Press and hold the Program button for four seconds. Release the button and the LED will display Fi followed by its setting.
2. When Fi (Figure 10) is displayed, press and release the Program button to view current setting.
3. To make a change, press and hold the Program button to scroll through settings - release the button at desired setting (Figure 11).
4. The unit automatically returns to the Flush Interval Mode if the Program button is not pressed within 10 seconds.

NOTE: Fi times are displayed in ten minute intervals, after fifty minutes they are displayed in hours (Table B).

TO SET Fd - FLUSH DURATION MODE

1. Press and hold the Program button for four seconds. Release the button, the LED displays Fd.
2. When Fd is displayed (Figure 12), press and release button to view current setting .
3. To make a change, press and hold down start button to scroll through settings - release button at desired setting (Figure 13).
4. After ten seconds, if start button is not pressed unit automatically returns to Flush Interval Mode.

NOTE: Fd times are displayed in 5 second intervals up to 60 seconds (Table B).

Fi - Flush Interval Mode	Fd - Flush Duration Mode
1- 10 minutes	5 5 seconds
5- 50 Minutes	10 10 seconds
01 1 Hour	15 15 Seconds
12 12 Hours	30 30 Seconds
24 24 hours	60 60 Seconds

Table B. LED Display Settings



Figure 10. Fi - LED Display for Flush Interval Mode

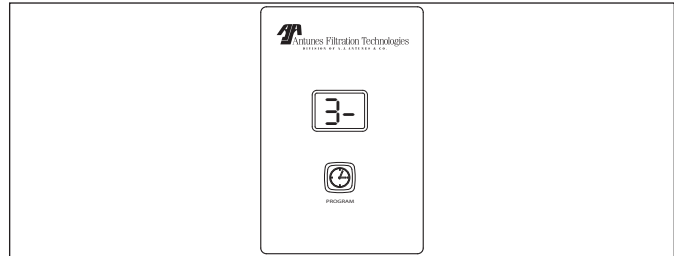

Figure 11. Time display for Fi Mode (30 Minutes)

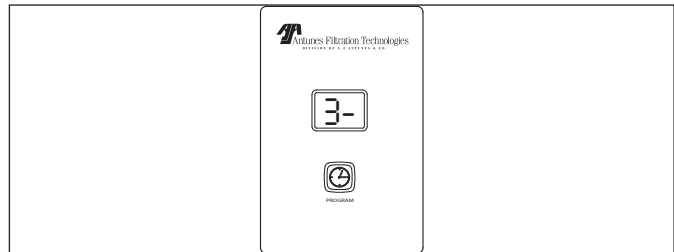

Figure 12. LED Display for Flush Duration

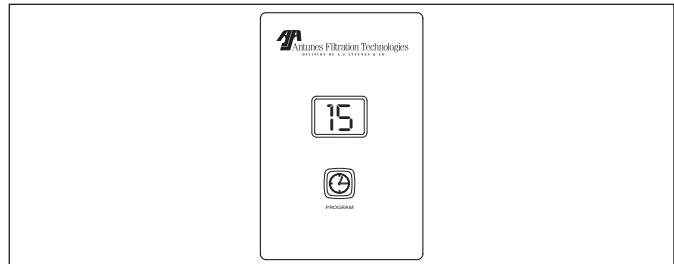

Figure 13. Time Display for Fd Mode (15 Seconds)

Manual Flushing

NOTE: Manual flushing only works when unit is in Flush Interval Mode (Fi).

While the unit is in Flush Interval Mode (decimal point flashing), hold the Program button down for 6-7 seconds until the LED displays FL (Figure 14). Continue holding the button down to keep the drain open. Drain will remain open for as long as Program button is depressed. (FL will flash on LED.) Releasing the button closes the drain and puts the unit back into startup mode. After ten seconds, if the Program button is not pressed the unit automatically returns to the Flush Interval Mode (Fi).

MAINTENANCE

The filtration system is designed to require very little maintenance. To ensure that the water is of the highest quality, occasionally some service is required.

Checking the Timer Program

During normal operation, the system displays the time setting for the Flush Interval Mode (FI) and the decimal will flash in one second intervals. This is the time between flushing, not a time of day setting.

Over time, it is possible that the time that the system flushes occurs at a time of high water use. If this creates a problem, the timer can be reset by unplugging the power cord, waiting for 5 seconds, and plugging the power cord in again. The timer then begins timing from the point power is restored to the system. Follow the procedures within the Operation section of this manual to check and set the timer settings.

Changing the Cartridges

While the filtration system is designed for long life, eventually the cartridges will need to be replaced.

NOTE: Do NOT operate the system without the Flow Regulator Assembly or the unit will be damaged, physical injury may occur, and the warranty will be voided.

1. Open the faucet or tap closest downstream to the filtration system.
2. Close the inlet water valve and allow the system to depressurize.
3. Place a bucket under the "T" or cross fitting at the inlet connection to the system. Open the valve or unscrew the cap to drain the system.
4. Press and hold the Start button to help drain the system.
5. Close the inlet drain valve or reattach the cap on the "T" fitting when the water flow stops.

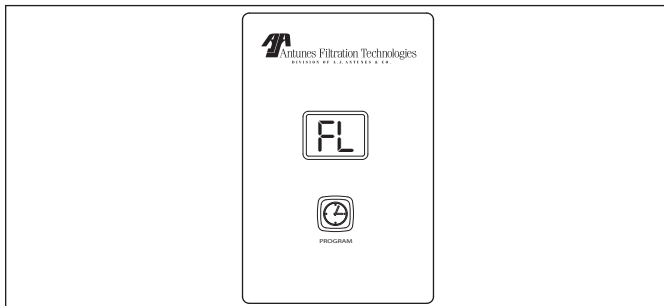

Figure 14. Manual Flush

6. Unplug the system.
7. **Make sure there is enough room below the housing to remove the cartridge.**
8. Remove the snap ring on the end of the housing. Grab the raised lug with your fingers or a pair of pliers and pull towards the center of the end cap and away. The ring should lift out of its groove.
9. The end cap, end cap O-ring, and cartridge should easily drop down out of the housing. If not, pull gently on the end cap to remove.
10. Inspect the cartridge O-rings and end cap O-ring for nicks or cuts. Replace as needed.
11. Lubricate all O-rings with a food-grade silicone lubricant. Apply a light coating of lubricant to the inside center tube at both ends of the new cartridge..
12. Place the end cap O-ring on the end cap and insert the end cap into the end of the new cartridge. Position the new cartridge and end cap below the housing and gently insert into the housing. Press the end cap into position until the end cap is fully seated and the snap ring groove is visible.
13. Install the snap ring by guiding the non-lugged end into the groove first, pushing outward and working around the ring until it snaps into place.

NOTE: Make sure that the snap ring is fully seated before turning the water on.

14. Follow the Flushing and Starting the System and Sanitizing the System and Lines procedures in the Installation section of this manual to complete the cartridge change.

If the cartridge does not easily come out of the housing, the opposite end cap can also be removed for assistance during Step 8. Remember to inspect and reinstall the O-rings at each end in the proper order.

System Sanitization

Over time and use, the plumbing downstream from the system may require sanitization. It is recommended that the system and downstream plumbing be sanitized at least once a year. When necessary, follow the Sanitizing the System and Lines procedure in the Installation section of this manual.

TROUBLESHOOTING

Problem	Possible Cause	Corrective Action
Unit does not have power.	The power cord is not correctly plugged in.	Plug power cord in correctly.
The Control Display is blank.	The power cord is not correctly plugged in.	Plug power cord in correctly.
	Control Board is inoperable.	Contact your maintenance person or Authorized Service agency.
	Transformer is inoperable.	
No water comes out of the filter system	Inlet Valve closed	Open the Inlet Valve
	Inlet Strainer is plugged	Clean/replace Inlet Strainer
	End of the capillaries plugged	Clean/replace Filter Cartridge
Low water flow/pressure out of system	See above.	See above.
	The system may be in a flush cycle.	Wait for the flush cycle to end.
	Flushing program not set correctly for water conditions.	Decrease the flush interval and increase the flush duration (refer to the Operation section of this manual).
	Drain Valve is stuck open.	Replace/rebuild the Drain Valve.
	The inlet water pressure is too low.	Boost the inlet water pressure/replace pipes.
Water tastes bad.	Storage/shipping solution not completely flushed out of system.	Flush system for a longer period of time.
	Biological growth in pipes.	Sanitize plumbing.
	Water conditions changed.	Consider installing taste and odor filtration.
	Broken capillary in Filter Cartridge.	Replace Filter Cartridge.
Flush runs continuously.	Drain Valve stuck open.	Replace/rebuild the Drain Valve.
	Controller sending continuous signal to valve.	Replace the controller.
Flush runs too long.	Program duration set too long.	Re-program the unit to flush for a shorter duration of time.
Flush occurs at time of high water usage.	The Flush Interval is set to interfere with water use.	Change Flush Interval/reprogram time. Unplug unit and plug in at a time of lower water usage.
Water splashes at drain during flush.	Drain line not positioned properly.	Reposition the end of the drain line.
Water leaks at the ends of the Filter Cartridge after changing cartridges.	Cartridge end connections are not tight enough.	Tighten with strap wrench if necessary.
	O-rings not lubricated.	Lubricate O-rings with food-grade lubricant.
	O-rings are split, cut, or twisted	Replace O-rings.
Water leaks from Permeate port.	Permeate port is not tight enough	Tighten, with strap wrench if necessary.
	O-ring not lubricated.	Lubricate O-ring with food-grade lubricant.
	O-ring split, cut, or twisted.	Replace O-ring.
Water leaks from system fitting or connection.	Fitting broken or loose.	Retighten or replace the fitting.
	Not enough pipe thread sealant used.	Redo the fitting with the proper amount of sealant.

WIRING DIAGRAM

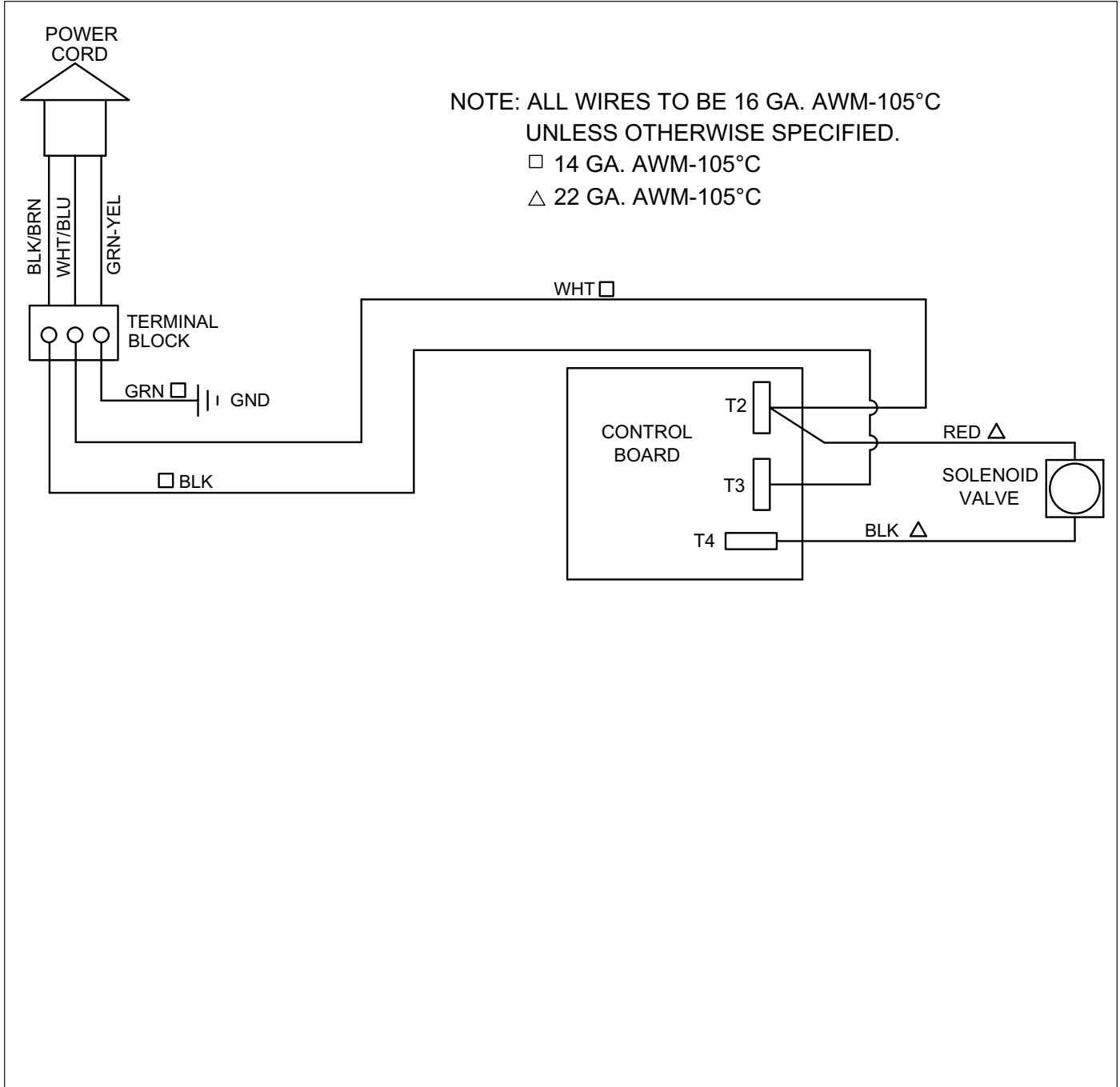

REPLACEMENT PARTS UFL-420/440 (continued)

Replacement Parts can be purchased from an authorized dealer. Contact Antunes Filtration Technologies at 1-630-754-1000 or toll free in the United States at 1-800-253-2991

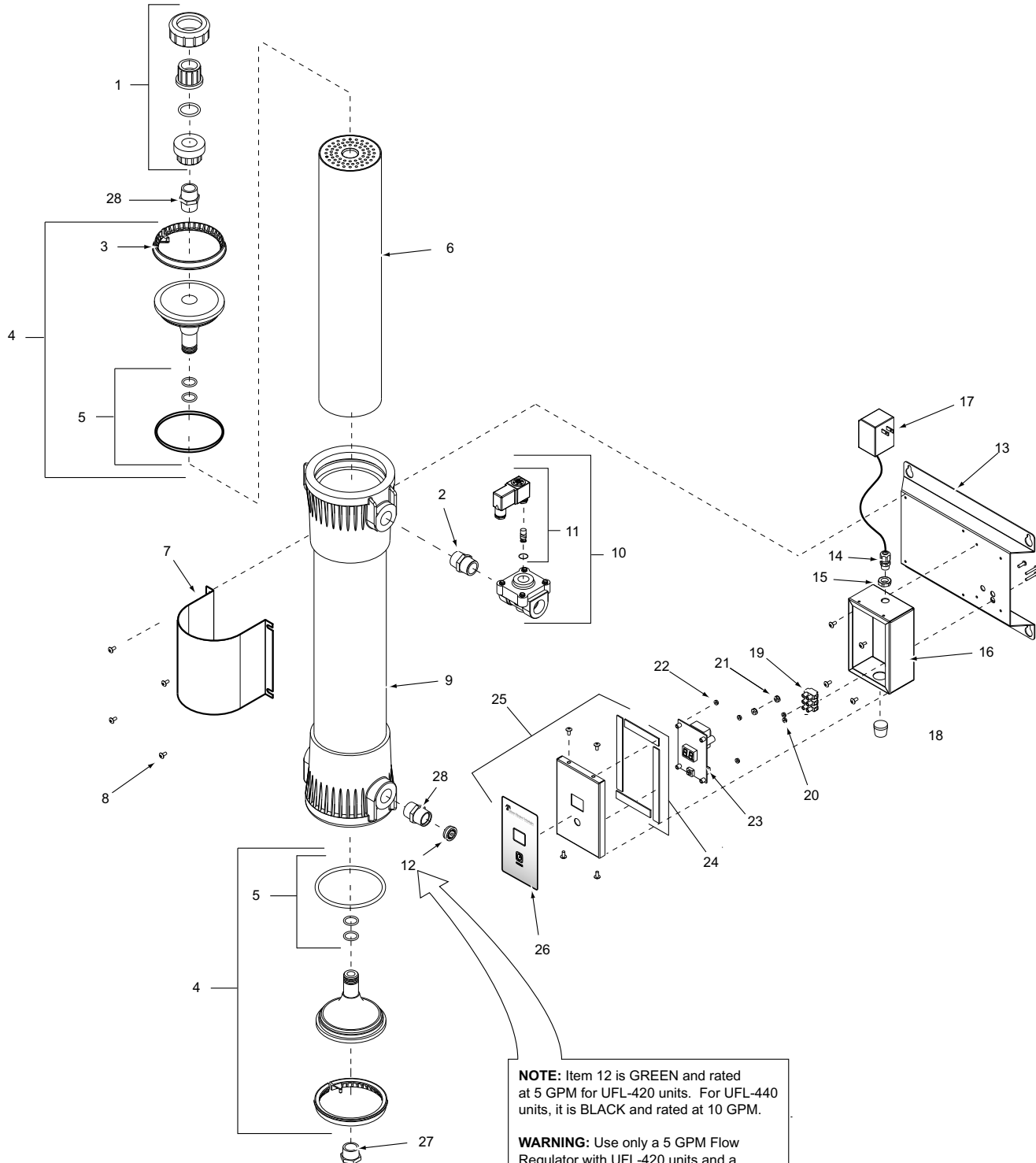

NOTE: Item 12 is GREEN and rated at 5 GPM for UFL-420 units. For UFL-440 units, it is BLACK and rated at 10 GPM.

WARNING: Use only a 5 GPM Flow Regulator with UFL-420 units and a 10 GPM Flow Regulator for UFL-440 units. Use of the wrong Flow Regulator will void the system warranty.

REPLACEMENT PARTS UFL-420/440

Replacement Parts can be purchased from an authorized dealer. Contact Antunes Filtration Technologies at 1-630-754-1000 or toll free in the United States at 1-800-253-2991

Item	Part No.	Description	Qty.
1	2190141	Union Assembly	1
2	2190144	Nipple, Hex 3/4" NPT x 1 1/2" LG	2
3	2180181	Ring, Lock	2
4	7000431	End Cap Kit Incl. 1 of P/N 7000413, 1 of P/N 2180181, and 1 of P/N 2180182	1
5	7000413	O-ring Replacement Kit Incl. 4 of PN 0200236, 2 of PN 0200235, and 1 of PN 2140153	1
6	7000411	Cartridge Replacement Kit UFL-420 Only (Includes O-ring Replacement Kit P/N 7000413)	1
	7000412	Cartridge Replacement Kit UFL-440 Only (Includes O-ring Replacement Kit P/N 7000413)	1
7	0504065	Clamp, 4" Filter	1
8	308P157	Screw, Tap #8-32 x 3/8" **	12
9	2180188	Housing, Filter UFL-420	1
	2180180	Housing, Filter UFL-440	1
10	4040173	Solenoid Valve 120V NC 3/4" NPT	1
	4040174	Solenoid Valve 230V NC 3/4" NPT	1
11	7000357	Solenoid Valve/Coil Kit 120 V	1
	7000358	Solenoid Valve/Coil Kit 230V	1
12	0021335	Flow Regulator Assembly *** 5 GPM - UFL-420 (Green)	1
	0021336	Flow Regulator Assembly *** 10 GPM - UFL-440 (Black)	1

Item	Part No.	Description	Qty.
13	0504033	Bracket, Mounting	1
14	0400334	Strain Relief - Small	1
15	040P333	Nut, Lock **	1
16	0503983	Control Housing	1
17	0700463	Power Cord, NEMA 5-15P, 120V	1
	0700634	Power Cord, CEE 7/7, 16 Amp, 250 VAC	1
18	040K251	Strain Relief Kit	1
19	4060355	Terminal Block, 3-Pole	1
20	306P101	Nut, Hex #6-32 **	2
21	308P143	Nut, Hex KEPS #8-32**	2
22	304P105	Nut, Hex KEPS #4-40 **	4
23	7000432	Timer, 115V	1
	7000433	Timer, 230V	1
24	7000359	Cover Gasket Kit	1
25	7000362	Control Housing Cover Kit Incl. items 24 and 26	1
26	1001116	Label, Timer	1
27	2190135	Plug, Pipe 3/4" NPT	2
33*	2140153	Lubricant, High-vacuum grease	1
34*	2140102	Sealant, Pipe	1
35*	2140144*	Tape, Pipe Thread	1
36*	0700636	Wire Set	1
37*	0700637	Wire Harness	1
38*	1001101	Label, Wiring Diagram	1
39*	1001133	Label, Inlet **	1
40*	1001135	Label, Drain **	1
41*	1001134	Label, Permeate **	1
42*	1010864	Owner's Manual	1

* Not Shown

** Only available in packages of 10.

*** **WARNING: Use only a 5 GPM Flow Regulator with UFL-420 units and a 10 GPM Flow Regulator for UFL-440 units. Use of the wrong Flow Regulator will void the system warranty.**

LIMITED WARRANTY

Equipment manufactured by Antunes Filtration Technologies, Division of A.J. Antunes & Co. has been constructed of the finest materials available and manufactured to high quality standards. These units are warranted to be free from mechanical and electrical defects for a period of one year from date of purchase or 18 months from shipment from factory, whichever occurs first, under normal use and service, and when installed in accordance with manufacturer's recommendations.

To insure continued proper operation of the units, follow the maintenance procedure outlined in the Owner's Manual.

1. This warranty does not cover cost of installation, defects caused by improper storage or handling prior to placing of the equipment. This warranty does not include overtime charges or work done by unauthorized service agencies or personnel. This warranty does not cover normal maintenance, calibration, or regular adjustments as specified in operating and maintenance instructions of this manual, and/or labor involved in moving adjacent objects to gain access to the Equipment. This warranty does not cover consumable items such as filtration membranes. **This warranty does not pay travel, mileage, or any other charges for an authorized service agency to reach the equipment location.**
2. Antunes Filtration Technologies reserves the right to make changes in design or add any improvements on any product. The right is always reserved to modify equipment because of factors beyond our control and government regulations. Changes to update equipment do not constitute a warranty charge.
3. **If shipment is damaged in transit, the purchaser should make a claim directly upon the carrier. Careful inspection should be made of the shipment as soon as it arrives and visible damage should be noted upon the carrier's receipt. Damage should be reported to the carrier. This damage is not covered under this warranty.**
4. Warranty charges do not include freight or foreign, excise, municipal or other sales or use taxes. All such freight and taxes are the responsibility of the purchaser.
5. THIS WARRANTY IS EXCLUSIVE AND IS IN LIEU OF ALL OTHER WARRANTIES, EXPRESSED OR IMPLIED, INCLUDING ANY IMPLIED WARRANTY OR MERCHANTABILITY OR FITNESS FOR A PARTICULAR PURPOSE, EACH OF WHICH IS HEREBY EXPRESSLY DISCLAIMED. THE REMEDIES DESCRIBED ABOVE ARE EXCLUSIVE AND IN NO EVENT SHALL ROUNDUP BE LIABLE FOR SPECIAL CONSEQUENTIAL OR INCIDENTAL DAMAGES FOR THE BREACH OR DELAY IN PERFORMANCE OF THIS WARRANTY.



A.J. Antunes & Co.

We exist to make our customers successful.

A.J. Antunes & Co.
Headquarters/Manufacturing
Carol Stream, Illinois 60188 USA
Phone: (630) 784-1000
Toll Free: (800) 253-2991
Fax: (630) 784-1650

Antunes Equipment
Manufacturing (Suzhou) Ltd.,
Suzhou, Jiangsu, China 215011
Phone: 86-512-6841-3637
Toll Free: 400-0-7878-22
Fax: 86-512-6841-3907

www.ajantunes.com