

MANUFACTURING

NUMBERS:

9700440
9700442
9700443
9700450
9700452
9700453

vizion™
by A.J. Antunes & Co.

***WATER FILTRATION
SYSTEM***

UF-420/440 Series



P/N 1010827 Rev. E 03/12

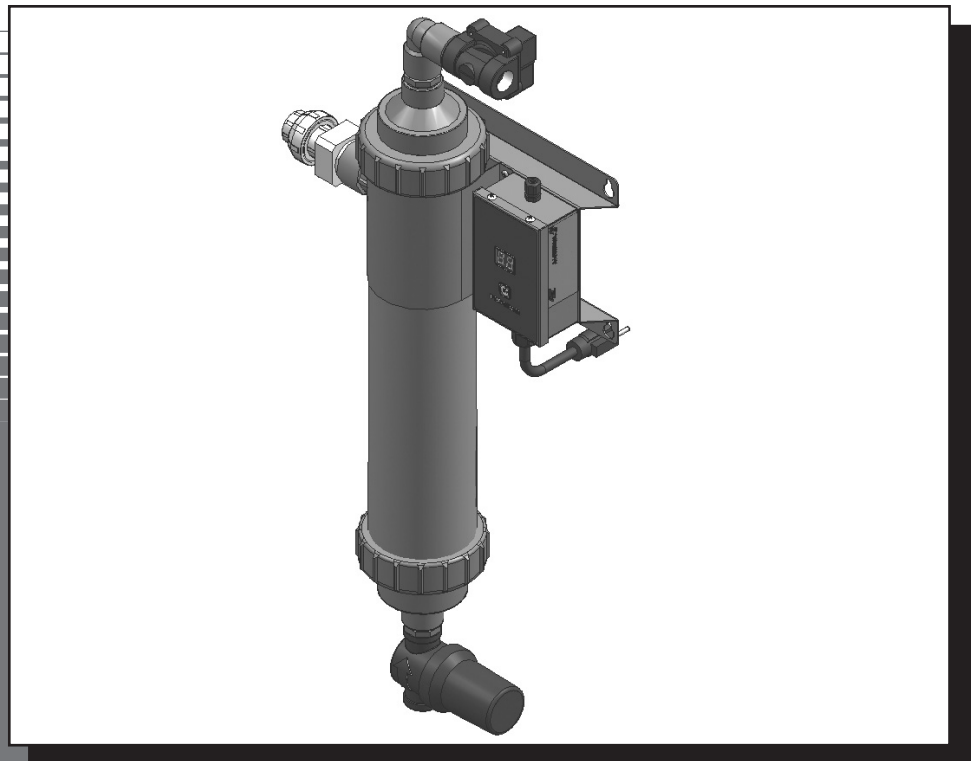

Owner's Manual

TABLE OF CONTENTS

Owner Information	2	Filtration Process.....	9
General.....	2	LED Display.....	9
Warranty Information	2	Operation.....	9
Service/Technical Assistance	2	Starting the System	9
Important Safety Information	3	Programming Timer During Startup.....	10
Specifications	4	Programming Timer During Interval (FI) Mode.....	10
Electrical Ratings.....	4	Manual Flushing	11
Electrical Cord & Plug Configurations	4	Maintenance.....	12
Dimensions	4	Checking the Timer Program.....	12
Specifications (Filter Cartridges)	4	Changing the Cartridges	12
Components	5	Troubleshooting	13
Installation.....	6	Replacement Parts UF-420/440	14
Unpacking.....	6	Wiring Diagram	14
Equipment Setup	6	LIMITED WARRANTY	Back Cover
Locating and Mounting the system	6		

OWNER INFORMATION

General

Antunes Filtration Technologies, a Division of A.J. Antunes & Company, has partnered with companies from around the globe to produce the UF-Series water filtration systems. The UF-Series removes bacteria and provides a substantial reduction of viruses that can enter a typical water supply. This patented technology is now available to you, sized for your particular application. All filter configurations utilize NeoH capillary membranes, providing the latest innovation in reusable surface filtration technology.

This manual provides the safety, installation and operating procedures for the UF-Series water filtration systems. We recommend that all information contained in this manual be read prior to installing and operating the unit.

Your UF-Series unit is manufactured from the finest materials available and is assembled to AFT's strict quality standards. This unit has been tested at the factory to ensure dependable trouble-free operation.

Warranty Information

Please read the full text of the Limited Warranty in this manual.

If the unit arrives damaged, contact the carrier immediately and file a damage claim with them. Save all packing materials when filing a claim. Freight damage claims are the responsibility of the purchaser and are not covered under warranty.

IMPORTANT! Keep these instructions for future reference. If the unit changes ownership, be sure this manual accompanies the equipment.

OWNER INFORMATION (continued)

Service/Technical Assistance

If you experience any problems with the installation or operation of your unit, contact Antunes Filtration Technologies at **1-630-784-1000**, or toll free in the United States only at **1-800-253-2991**.

Fill in the information in the next column and have it handy when calling for assistance. The serial number is on the specification plate located on the unit.

Purchased From: _____

Date of Purchase: _____

Model No.: _____

Serial No.: _____

Mfg. No.: _____

IMPORTANT

A.J. Antunes and Company reserves the right to change specifications and product design without notice. Such revisions do not entitle the buyer to corresponding changes, improvements, additions or replacements for previously purchased equipment.

Throughout this manual, you will find the following safety words and symbols that signify important safety issues with regards to operating or maintaining the unit.

In addition to the warnings and cautions in this manual, use the following guidelines for safe operation of the unit.

WARNING

GENERAL WARNING. Indicates information important to the proper operation of the equipment. Failure to observe may result in damage to the equipment and/or severe bodily injury or death.

WARNING

ELECTRICAL WARNING. Indicates information relating to possible shock hazard. Failure to observe may result in damage to the equipment and/or severe bodily injury or death.

CAUTION

GENERAL CAUTION. Indicates information important to the proper operation of the equipment. Failure to observe may result in damage to the equipment.

- Read all instructions before using equipment.
- Install or locate the equipment only for its intended use as described in this manual. Do not use corrosive chemicals in this equipment.
- Do not operate this equipment if it has a damaged cord or plug; if it is not working properly, or if it has been damaged or dropped.
- This equipment should be serviced by qualified personnel only. Contact Everpure for repair.
- Do not immerse cord or plug in water.
- Keep cord away from heated surfaces.

IMPORTANT SAFETY INFORMATION (continued)

The following warnings and cautions appear throughout this manual and should be carefully observed.

- Disconnect the power source before performing any service or maintenance on the unit.
- All electrical connections must be in accordance with local electrical codes and any other applicable codes.
- **WARNING ELECTRICAL SHOCK HAZARD. FAILURE TO FOLLOW THESE INSTRUCTIONS COULD RESULT IN SERIOUS INJURY OR DEATH.**
 - Do not modify the power supply cord plug. If it does not fit the outlet, have a proper outlet installed by a qualified electrician.
 - Do not use an extension cord with this appliance.
- If the supply cord is damaged, it must be replaced by the manufacturer or its service agent or a similarly qualified person.
- This equipment is to be installed to comply with the local plumbing code and any other applicable code.

IMPORTANT SAFETY INFORMATION

- Water pressure must not exceed the membrane differential pressure of 45 psig (3.1 bar). To reduce water pressure, install a water pressure regulator and set system inlet water pressure to 45 psi (3.1 bar).

Protect from becoming dry

If the membrane dries out, irreversible damage to the membrane may result. Protect the filter from becoming dry by keeping it wet and sealed at all times.

Protect from freezing

If the membrane freezes during operation or storage, irreversible damage to the membrane and brittle cracking of the cartridge or housing may result.

Protect from direct sunlight or other UV sources

Avoid long-term exposure to direct sunlight or other UV sources. The filter should be stored in a dark spot.

Protect from high temperatures or abrupt variation in temperature

The maximum operating temperature is 100oF (40oC). Avoid abrupt variations in temperature. Any temperature variation should be made slowly.

Protect from rough handling or dropping

Mechanical damage, external breakage, and/or internal breakage of the filter can result if the system is dropped or bumped. Handle with care at all times during transportation and installation.

Protect from organic solvents and concentrated acids

Prevent any and all contact of the membrane with strong solvents, solvents containing chlorine, or concentrated acids. Do not use strong solvents or concentrated acids on any plastic parts of the filter system. Examples of some solvents to avoid: acetone, methyl acetate (nail polish remover); hexane (spot removers); turpentine, toluene (paint thinners); dry cleaning solutions, insecticides.

Protect from abrasive material

The membranes must be protected from abrasive materials like shavings left in a pipe. Abrasive materials in contact with the membrane can cause irreversible damage to the membrane. All pipes must be flushed clean before installing the filter. All plastic parts of the filter system must be protected from sharp objects like knives, sand paper or other tools. Cutting or nicking a plastic part can weaken it and cause a leak. Do not use abrasive cleansers on any plastic parts.

Protect from water hammer

The system must be protected from shock, pressure surges, or pulsation that may occur inside water pipes. Water hammer occurs in pipes when a valve or faucet shuts quickly. Install a water hammer arrestor (pressure vessel containing compressed air separated from the water by a diaphragm) to reduce pressure shock.

WATER CONDITION EQUIPMENT GUIDELINES

The following table describes the required or recommended equipment and suggested flush programming to be used with your filtration system based on the Inlet Water Pressure, Inlet Turbidity, and daily water use.

Inlet Water Pressure (psi)	Inlet Turbidity (NTU)	Required Additional Equipment Installed	Water Use (Gallons Per Day)	Flush Program
Less than 45 psi	Less than 1 NTU	<i>Required:</i> No additional equipment <i>Recommended:</i> Inlet water strainer (150 micron/ 100 mesh screen) <i>Recommended:</i> Permeate Tank	Less than 300 GPD	Flush Program: Interval: 6 hour Duration: 15 seconds
			Greater than 300 GPD	Flush Program: Interval: 1 hour Duration: 15 seconds
Greater than 45 psi	Less than 1 NTU	<i>Required:</i> Pressure regulator <i>Recommended:</i> Inlet water strainer (150 micron/ 100 mesh screen) <i>Recommended:</i> Permeate Tank	Less than 300 GPD	Flush Program: Interval: 6 hour Duration: 15 seconds
			Greater than 300 GPD	Flush Program: Interval: 1 hour Duration: 15 seconds
Less than 45 psi	Greater than 1 NTU	<i>Required:</i> Inlet water strainer (150 micron/ 100 mesh screen) <i>Required:</i> Permeate Tank	Any	Flush Program: Interval: 1 hour Duration: 15 seconds
Greater than 45 psi	Greater than 1 NTU	<i>Required:</i> Pressure regulator <i>Required:</i> Inlet water strainer (150 micron/ 100 mesh screen) <i>Required:</i> Permeate Tank	Any	Flush Program: Interval: 1 hour Duration: 15 seconds

SPECIFICATIONS

Electrical Ratings

Model	Voltage	Watts	Hertz
UF-420	120	10	50/60
UF-440	230	10	50/60

Electrical Cord & Plug Configurations

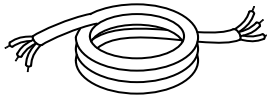
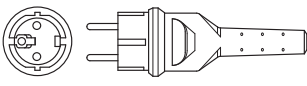
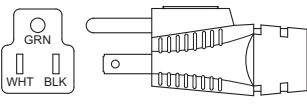
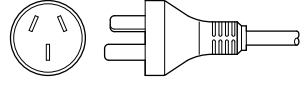
Letter Code*	Description	Configuration
C	Commercial Cord	
H	Harmonized Cord	
(H)C**	CEE 7/7, 16 Amp., 250 VAC (Assembly Only).	
(C)F***	5-15P, 15 Amp., 120 VAC., Non – Locking (Assembly Only).	
(H)K	Chinese/Australian, 10 Amp., 250 VAC. (Assembly only)	

* Used in Model Designation

** Indicates that the Plug comes with a Harmonized Cord

** Indicates that the Plug comes with a Commercial Cord

Filter Cartridge Capacities

Maximum Operating Pressure	100 psig (690 kPa)
Maximum Operating Temp.	104°F (40°C)
Minimum Operating Temp.	40° F (4° C)
Maximum Membrane Differential Pressure	45 psi
pH Range	3-10
MWCO	100 kD

System Capacities

Series	UF-420	UF-440
Liters per hour	1500	2000
Liters per minute	25	33.3
Gallons per hour	396	528
Gallons per minute	6.6	8.8

⚠ WARNING ⚠

ELECTRICAL SHOCK HAZARD.

FAILURE TO FOLLOW THE INSTRUCTIONS IN THIS MANUAL COULD RESULT IN SERIOUS INJURY OR DEATH.

- Electrical ground is required on this appliance.
- Do not modify the power supply cord plug. If it does not fit the outlet, have a proper outlet installed by a qualified electrician.
- Do not use an extension cord with this appliance.
- Check with a qualified electrician if you are in doubt as to whether the appliance is properly grounded.

⚠ CAUTION ⚠

All electrical connections must be in accordance with local electrical codes and any other applicable codes.

SPECIFICATIONS (continued)

Dimensions

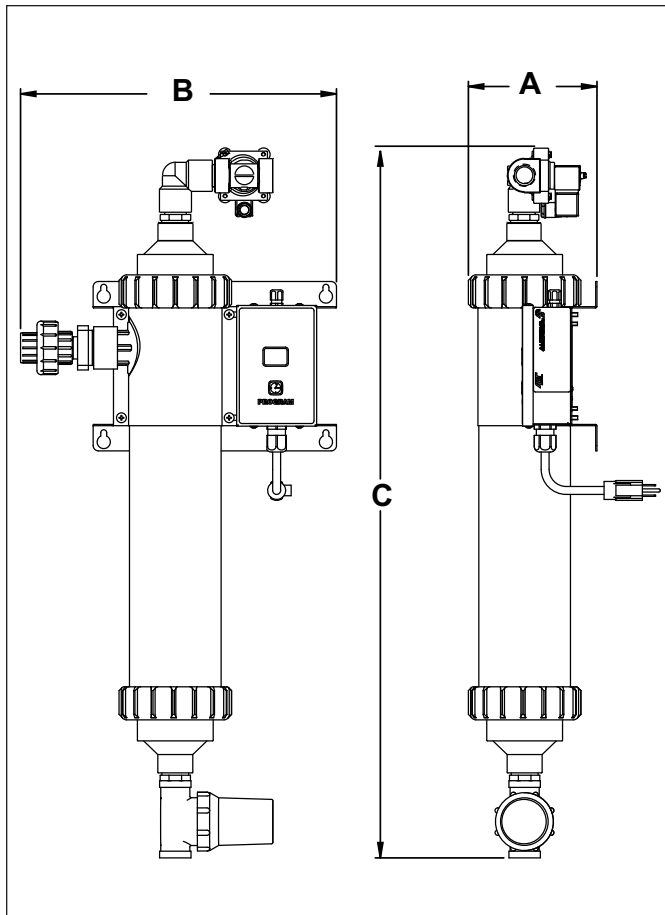

Figure 1. Dimensions

Unit	A Width (inches)	B Depth (inches)	C Height (inches)	Operating Weight (w/water) (lbs)
UF-420	6-1/16	14-7/8	33-7/8	30
UF-440	6-1/16	14-27/32	53-17/32	51

Components

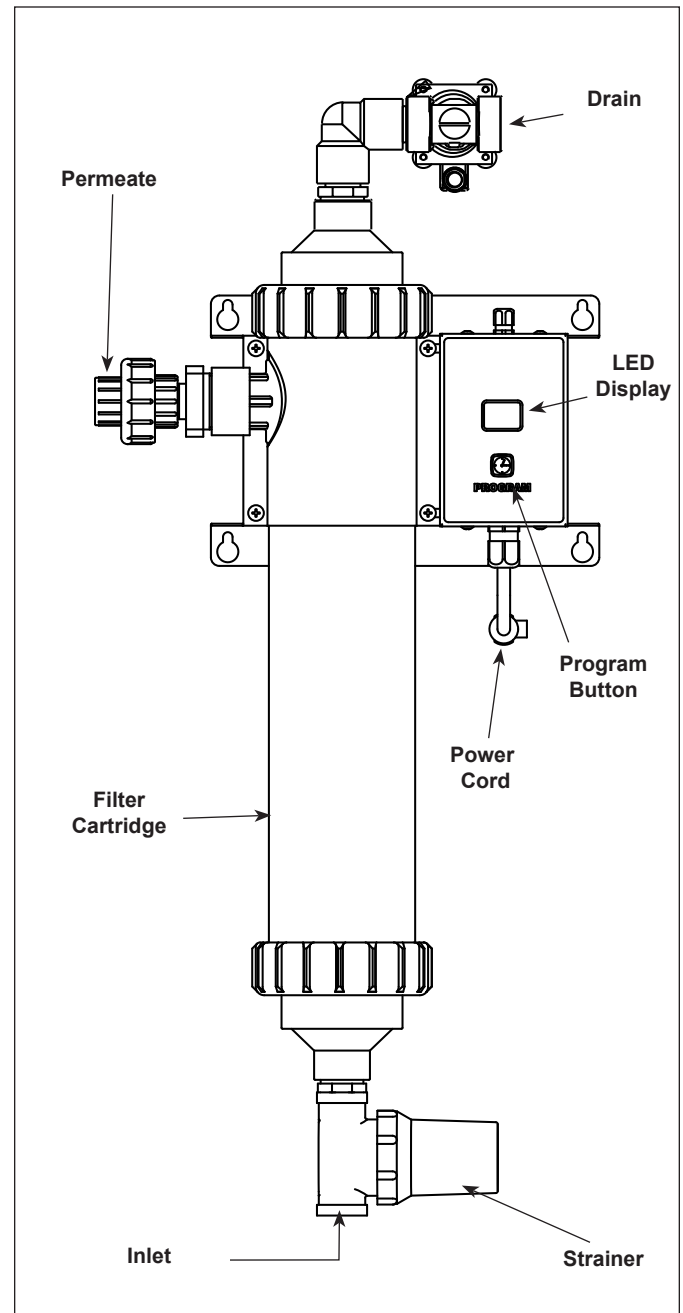

Figure 2. Components

INSTALLATION

Unpacking

1. Remove the system and all packing materials from the shipping carton.
2. Remove all packing materials and protective coverings from the system
3. Remove the information packet. To prevent any delay in obtaining warranty coverage, fill out and mail the warranty card.

NOTE: If any parts are damaged, contact Antunes Filtration Technologies IMMEDIATELY at 1-800-253-2991 (in the U.S. only) or 1-630-784-1000.

Equipment Setup

GENERAL

When placing the unit into service, pay attention to the following guidelines:

- Make sure power to the unit is off.
- Do not immerse cord or plug in water.
- Keep cord away from heated surfaces.

ELECTRICAL

Ensure that the line voltage corresponds to the stated voltage on the units specification label. Make sure that the plug on the power cord from the system and the outlet match. For proper operation, and to ensure the highest quality water from the system, make sure that the system is not connected to a switched electrical outlet.

PLUMBING

NOTE: This unit is designed to use tap water not to exceed 104°F (40°C).

The UF-420 and UF-440 systems use the following connections (Figure 1):

- Water Inlet 3/4" NPT
- Permeate (Product Water) 3/4" NPT
- Drain 3/4" NPT

When making a plumbing connection to the system, remember to use a back-up wrench on the supporting plumbing. Always use a good quality, approved, pipe sealant or thread seal tape on pipe threads. Be careful not to get the pipe sealant inside the pipe when making the connections.

Do not over-tighten the connections. It is recommended that plastic fittings be used when connecting to the

plastic connections of the system. This will reduce the possibility of cracking the connections due to overtightening.

If soldered plumbing is used, do not apply heat to, or near, the filtration system. The use of union (O-ring seal) connections is highly recommended for ease of installation and future servicing.

SUGGESTED TOOLS AND SUPPLIES FOR INSTALLATION

The following tools and supplies are suggested to make the installation easier:

- Screwdriver
- Drill with bits
- Strap wrench (up to 6" diameter)
- Tape measure
- Two gallon bucket
- Fresh 5 1/4% liquid chlorine bleach
- Adjustable wrenches
- Pipe wrenches
- Level
- Pipe dope or thread seal tape

⚠ CAUTION ⚠

This equipment is to be installed to comply with the basic plumbing code of the Building Officials and Code Administrators, Inc. (BOCA) and the Food Service Sanitation Manual of the Food and Drug Administration (FDA).

⚠ CAUTION ⚠

Water pressure must not exceed a membrane burst pressure of 7 bar (100 psi). To reduce water pressure, install a water pressure regulator and set water pressure to suit application. Note that the trans membrane pressure must be .5 - 2.5 bar (7 - 36 psi).

Locating and Mounting the system

Consider these points before mounting the system:

- Note the location of the water supply, drain, and an appropriate electrical outlet when choosing a mounting location.
- Remember to allow for access to the timer/ programmer controls.
- Do not mount the system above any electrical equipment, or above items that may be damaged if they get wet.

INSTALLATION (continued)

- Install the system in a location that will allow for future service access.
- Mount the system on a wall using appropriate mounting hardware.
- Remember to consider the operating weight of the system when choosing mounting hardware. Depending on the type of wall the system is being mounted to, wall reinforcement may be necessary.

Mount the filtration unit using the Mounting Bracket (Figure 3) using 1/4" by 1" bolts or bolts of the metric equivalent.

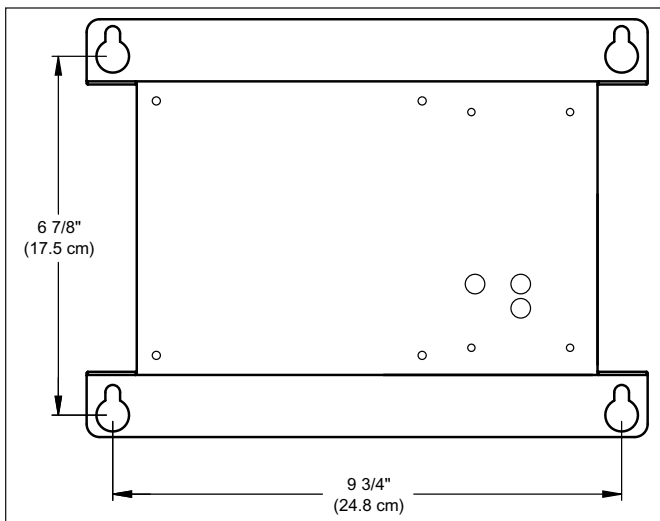

Figure 3. Mounting Bracket (Front View)

INLET WATER PLUMBING

It is recommended that the inlet water plumbing line be 3/4" NPT or larger. A shutoff valve (not supplied) should be installed in the line leading to the system. The valve should be mounted close to the system inlet and sized properly for the inlet plumbing line. This valve will allow for easier servicing and future cartridge change-out. The system should only be connected to the cold water line.

To ensure that the highest quality water is produced from the system, the plumbing leading to the filter system must be flushed clear of all debris before the system is hooked up. Before making the connection to the inlet of the filter system, hold a bucket or other container at the inlet water line and slowly open the inlet water valve. Allow the pipe to flush until all debris is removed.

PERMEATE LINE PLUMBING

To ensure the highest quality and safest water, it is recommended that a check valve (to prevent backflow) is installed in the water line after the permeate connection. This helps prevent possible contamination of the filter system due to other equipment downstream. The check valve (not supplied) should be mounted close to the system outlet and sized properly for the plumbing line. Check with local codes for the proper specification.

DRAIN LINE PLUMBING

The drain line is used to flush away the particle buildup when cleaning the filter. The drain line must be able to support the flow rate when the system flushes. The flow rate from the flush depends on the inlet water pressure, inlet pipe size, and system selected. It is recommended that the drain line be as large as, or larger than, the inlet plumbing line. The drain line should be as short as possible, sloping downward without kinks or loops. Be sure that the drain used is not blocked or restricted.

The filter system must be protected from possible back contamination by the installation of an air gap between the drain connection of the system and the drain (Figure 4). This gap in the line, with no physical contact between the system and sewer, prevents contamination of the system in the event of a backed-up sewer.

NOTE: Make sure that the end of the drain line is positioned and secured at least 2 inches above the drain so that the water flow is directed into the drain, without splashing.

FLUSHING AND STARTING THE SYSTEM

To ensure that the highest quality water is produced from the system, the plumbing leading from the filter system must be flushed clear of all debris after the system is hooked up. After making the connection to the outlet of the filter system, open a faucet or tap closest to the filter system, then slowly open the inlet water valve. Allow the pipe to flush until all debris is removed.

The unit also must be flushed to remove air and the shipping/storage solution. For maximum quality, the permeate water produced during the flushing procedure must be discarded. Direct this permeate water to drain.

INSTALLATION (continued)

1. Plug the power cord into the appropriate electrical outlet. The unit will power up and the LED display will display the following for about two seconds each:

- 8.8
- F8 followed by its time settings in seconds
- Fi and its time setting in minutes or hours.

The F8 and Fi sequence repeats for 30 seconds after which the unit automatically returns to the Flush Interval Mode (Fi). The time setting for Fi will be displayed and the decimal point will flash in one second intervals.

CAUTION

Ingesting the protective solution may cause irritation of the gastrointestinal tract, colic, diarrhea, or other similar symptoms

2. Open the tap or faucet closest downstream to the filter system.
3. Slowly open the inlet water valve and allow water to enter the system.
4. Press and hold the Start button. After 6-7 seconds, the drain valve will open and FL will appear on the display.
5. Continue holding the Start button down for at least 30 seconds to keep the drain open. This flushes air out of the center of the hollow fibers of the cartridge filter. The drain will remain open as long as the Start button is pressed. Check to make sure that the drain water is directed into the drain without splashing.
6. Release the Start button. This closes the drain valve. Water should continue to flow through the system and out of the open tap. Allow water to flow out of the tap for at least 15 minutes at maximum flow rate.
7. Close the tap and let the system stand without water flow for 15 minutes to allow any trapped air to come out of the hollow fibers. Check for leaks at all fittings.
8. After 15 minutes without water flow, open the tap for 5 minutes to allow any trapped air to be flushed out.
9. Close the tap. Flushing is complete.

SANITIZING THE SYSTEM AND LINES

The plumbing must be sanitized to eliminate possible contamination that may have occurred during the installation process. Chlorine bleach can be used to sanitize the plumbing. The amount of bleach used depends on the size of the system installed and the amount of plumbing downstream of the filter system. Generally, one ounce (30 ml) of bleach will be sufficient to sanitize the system.

1. Make sure that the system has been flushed of air and debris as described in the Flushing and Starting up the System section of this manual.
2. Open the tap closest downstream to the filtration system and close the inlet water valve and allow the system to depressurize.
3. Place a bucket under the strainer at the inlet connection to the system. Open the strainer by unscrewing the cap. Water will flow out of the strainer as the system drains.
4. When the water flow from the strainer stops, pour the liquid bleach into the strainer. Be careful not to spill bleach onto clothing or skin. Re-attach the cap on the strainer.
5. Slowly open the inlet water valve and allow water to flow out of the tap until the smell of bleach is present.
6. Close the tap and let the system stand without water flow for at least 15 minutes to allow the bleach to sanitize the pipes.
7. After 15 minutes without water flow, open the tap and flush until the presence of bleach is gone. All other taps should be opened to flush any bleach from the plumbing.
8. Close the tap. The sanitization is complete.

Program the timer following the procedure outlined in the Operation section of this manual.

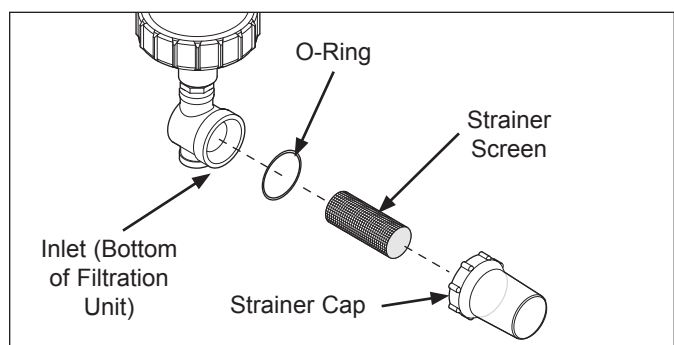

Figure 4. Sanitizing the System

INSTALLATION (continued)

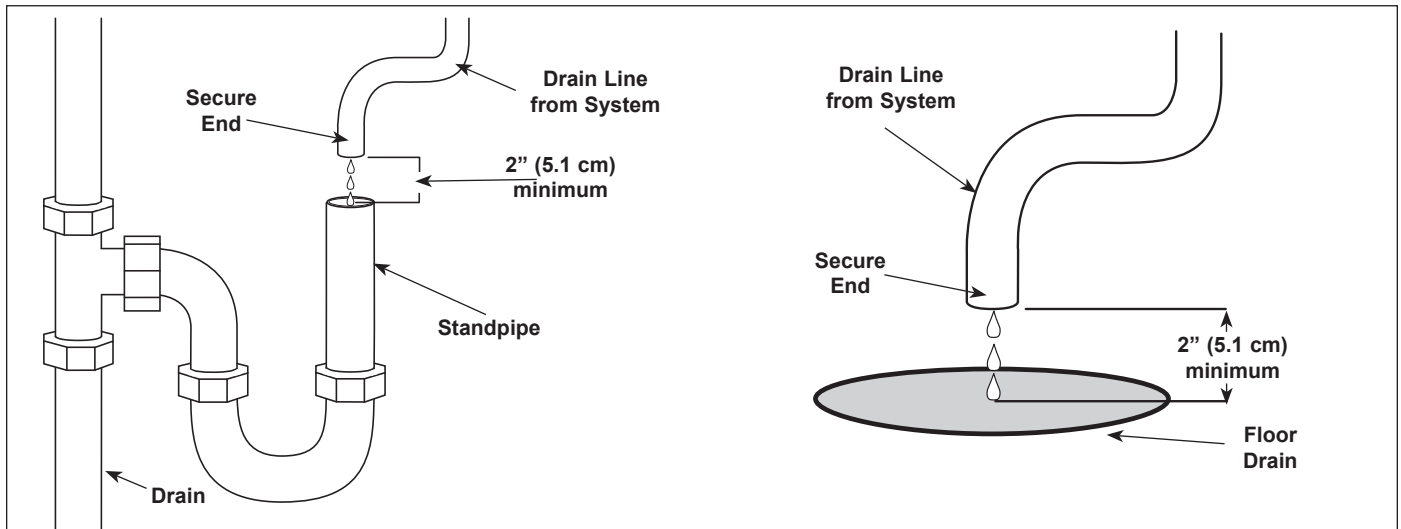

Figure 4. Proper Draining

OPERATION

Filtration Process

Water filtration in the UF Series is accomplished using two modes:

- Flush Interval (F_i on the LED display)
- Flush Duration (F_d on LED display).

During the Flush Interval mode, water enters the inlet and flows through the filter element before exiting the Permeate outlet as usable product water. After a certain period of time, depending upon water quality, the filter has to be cleaned. This is accomplished through the Flush Duration Mode. During this mode, the drain valve opens and flushes the membrane to remove debris collected inside the membrane walls.

NOTE: Both the Flush Interval Mode and the Flush Duration Mode can be automated by programming the timer. During the Flush Interval Mode, the valve is not powered in order to keep water filtering during a power outage.

LED Display

F_i - Flush Interval Mode is the time between flushings and is displayed in minutes or hours.

F_d - Flush Duration Mode is the amount of time used to flush and remove debris from filter cartridge and is displayed in seconds.

FL - Manual Flush Mode operation, solenoid is manually activated by the user.

Starting the System

Power up the unit.

The LED read-out displays the following for about two seconds each:

1. 8.8
2. F_d followed by its time settings in seconds.
3. F_i and its time setting, in minutes or hours.

The F_d and F_i sequence repeats for 30 seconds after which, the unit automatically returns to the Flush Interval Mode (F_i). The time setting for F_i will be displayed and the decimal point will flash in one second intervals.

NOTE: The timer can be programmed immediately after start-up or while in Flush Interval Mode.

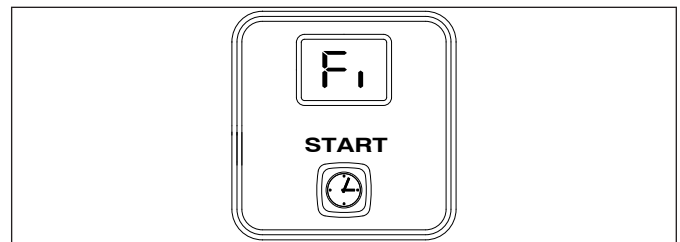

Figure 5. LED Display, Front Panel

OPERATION (continued)

Programming Timer During Startup

NOTE: Once the UF unit is powered up, the LED display cycles through the default or current settings: Flush Duration (Fd) and its setting will be followed by Flush Interval (Fi) and its settings. At any time during this sequence (which lasts approximately 30 seconds) the UF unit can be programmed.

SETTING THE FLUSH INTERVAL (FI)

1. When Fi (Figure 5) is displayed, press and release the Start button to view the current setting.
2. To make a program change, press and hold the Start button to scroll through settings - release the Start button at the desired setting (Figure 5).
3. If, after ten seconds, the Start button is not pressed, the unit automatically returns to the Flush Interval Mode.

NOTE: Flush Interval times are displayed in ten minute intervals. After fifty minutes, Flush Interval times are displayed in hours (Table A).

SETTING FLUSH DURATION (FD)

2. When Fd is displayed, press and release the Start button to view the current setting (Figure 8).
3. To make a program change, press and hold the Start button to scroll through settings - release the Start button at the desired setting (Figure 9).
4. After ten seconds, unless button is depressed, unit automatically returns to Flush Interval Mode.

NOTE: Fd times are displayed in 5 second intervals up to 60 seconds (Table A).

Fi - Flush Interval Mode	Fd - Flush Duration Mode
1- (10 minutes)	5 (5 seconds)
5- (50 Minutes)	10 (10 seconds)
01 (1 Hour)	15 (15 Seconds)
12 (12 Hours)	30 (30 Seconds)
24 (24 hours)	60 (60 Seconds)

Table A. LED Display Settings

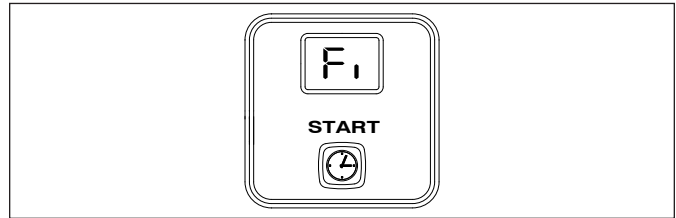

Figure 6. LED Display for Flush Interval Mode

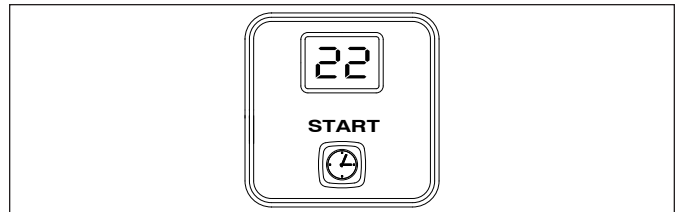

Figure 7. Time Setting Fi Mode (22 Hours)

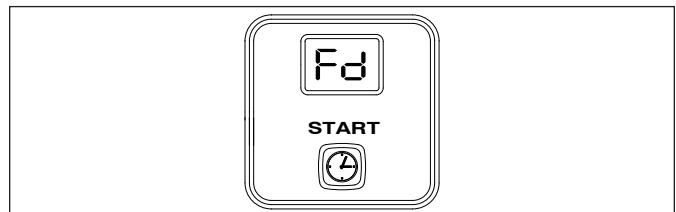

Figure 8. LED Display for Flush Duration Mode

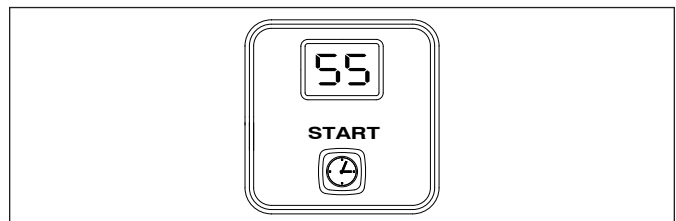

Figure 9. Time Setting Fd Mode (55 Seconds)

Programming Timer During Interval (FI) Mode

TO SET FI - FLUSH INTERVAL MODE

NOTE: After power-up and cycling - Fi time setting displays a flashing decimal point.

1. Press and hold down start button for four seconds. Release button, LED will display Fd followed by its setting.
2. When Fi (Figure 10) is displayed, press and release button to view current setting.
3. To make a change, press and hold down the start

OPERATION (continued)

button to scroll through settings - release button at desired setting (Figure 11).

4. After ten seconds, if start button is not pressed, unit automatically returns to Flush Interval Mode.

NOTE: Fi times are displayed in ten minute intervals, after fifty minutes they are displayed in hours (Table B).

TO SET FD - FLUSH DURATION MODE

1. Press and hold the Start button for four seconds. Release button, LED will display Fd.
2. When Fd is displayed (Figure 12), press and release the Start button to view the current setting
3. To make a change, press and hold the Start button to scroll through settings - release the Start button at desired setting (Figure 13).
4. If, after ten seconds, the Start button is not pressed, the unit automatically returns to the Flush Interval Mode.

NOTE: Fd times are displayed in 5 second intervals up to 60 seconds (Table B).

Fi - Flush Interval Mode	Fd - Flush Duration Mode
1- (10 minutes)	5 (5 seconds)
5- (50 Minutes)	10 (10 seconds)
01 (1 Hour)	15 (15 Seconds)
12 (12 Hours)	30 (30 Seconds)
24 (24 hours)	60 (60 Seconds)

Table B. LED Display Settings

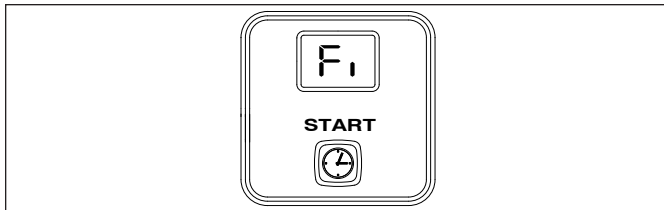

Figure 10. Fi - LED Display for Flush Interval Mode

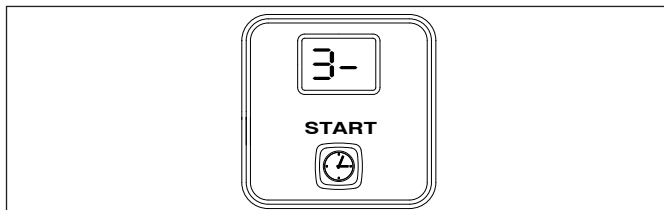

Figure 11. Time display for Fi Mode (30 Minutes)

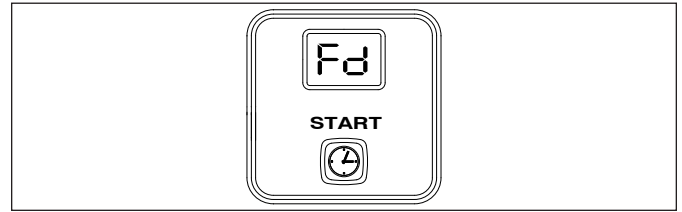

Figure 12. LED Display for Flush Duration

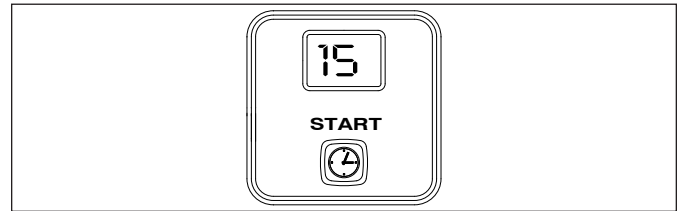

Figure 13. Time Display for Fd Mode (15 Seconds)

Manual Flushing

NOTE: Manual flushing only works when unit is in Flush Interval Mode (Fi).

While the unit is in Flush Interval Mode (decimal point flashing), hold the start button down for 6-7 seconds until the LED displays FL (Figure 14). Continue holding the button down to keep the drain open. Drain will remain open for as long as start button is depressed. (FL will flash on LED.) Releasing the button closes the drain and puts the unit back into startup mode. After ten seconds, if the start button is not pressed the unit automatically returns to the Flush Interval Mode (Fi).

MAINTENANCE

The filtration system is designed to require very little maintenance. To ensure that the water is of the highest quality, occasionally some service is required.

Checking the Timer Program

During normal operation, the system displays the time setting for the Flush Interval Mode (FI) and the decimal will flash in one second intervals. This is the time between flushing, not a time of day setting.

Over time, it is possible that the time that the system flushes occurs at a time of high water use. If this creates a problem, the timer can be reset by unplugging the power cord, waiting for 5 seconds, and plugging the power cord in again. The timer then begins timing from the point power is restored to the system. Follow the procedures within the Operation section of this manual to check and set the timer settings.

Changing the Cartridges

While the filtration system is designed for long life, eventually the cartridges will need to be replaced.

1. Open the faucet or tap closest downstream to the filtration system.
2. Close the inlet water valve and allow the system to depressurize.
3. Place a bucket under the strainer at the inlet connection to the system. Open the strainer by unscrewing the cap. Water will flow out of the strainer as the system drains.
4. Press and hold the Start button to help drain the system.
5. Reattach the cap on the strainer when the water flow stops. Unplug the power cord.

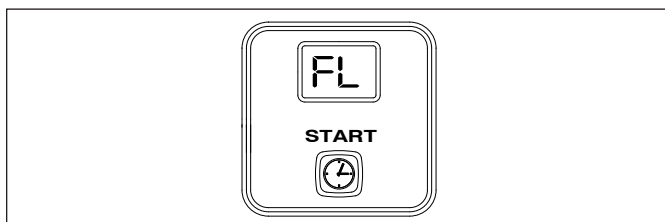

Figure 14. Manual Flush

6. Using a strap wrench (up to 6" capacity), loosen the top and bottom end caps. **DO NOT** remove the top and bottom End Caps yet.
7. Disconnect the permeate port connection.

8. Using a screwdriver, remove the screws from the cartridge bracket and set the bracket and screws aside.
9. Unscrew the cartridge end caps from the cartridge, being careful to retain the O-rings from each cap. Set the O-rings aside.
10. Install a new cartridge to the system using the cartridge bracket and screws saved from Step 8.
11. Connect the permeate port connection.
12. Inspect the O-rings to make sure they are clean and are not splitting or cut. For all O-rings, make sure they are lubricated with an approved food grade lubricant acceptable for drinking water use.
13. For each end cap, position the O-ring between the end of the cartridge and cap and screw the cap onto the cartridge. Tighten with strap wrench as necessary.
14. Follow the Flushing and Starting the System and Sanitizing the System and Lines procedures in the Installation section of this manual to complete the cartridge change.

System sanitization

Over time and use, the plumbing downstream from the system may require sanitization. It is recommended that the system and downstream plumbing be sanitized at least once a year. When necessary, follow the **Sanitizing the System and Lines** procedure in the Installation section of this manual.

TROUBLESHOOTING

Problem	Possible Cause	Corrective Action
Unit does not have power.	The power cord is not correctly plugged in.	Plug power cord in correctly.
The Control Display is blank.	The power cord is not correctly plugged in.	Plug power cord in correctly.
	Control Board is inoperable.	Contact your maintenance person or Authorized Service agency.
	Transformer is inoperable.	
No water comes out of the filter system	Inlet Valve closed	Open the Inlet Valve
	Inlet Strainer is plugged	Clean/replace Inlet Strainer
	End of the capillaries plugged	Clean/replace Filter Cartridge
Low water flow/pressure out of system	See above.	See above.
	The system may be in a flush cycle.	Wait for the flush cycle to end.
	Flushing program not set correctly for water conditions.	Decrease the flush interval and increase the flush duration (refer to the Operation section of this manual).
	Drain Valve is stuck open.	Replace/rebuild the Drain Valve.
	The inlet water pressure is too low.	Boost the inlet water pressure/replace pipes.
Water tastes bad.	Storage/shipping solution not completely flushed out of system.	Flush system for a longer period of time.
	Biological growth in pipes.	Sanitize plumbing.
	Water conditions changed.	Consider installing taste and odor filtration.
	Broken capillary in Filter Cartridge.	Replace Filter Cartridge.
Flush runs continuously.	Drain Valve stuck open.	Replace/rebuild the Drain Valve.
	Controller sending continuous signal to valve.	Replace the controller.
Flush runs too long.	Program duration set too long.	Re-program the unit to flush for a shorter duration of time.
Flush occurs at time of high water usage.	The Flush Interval is set to interfere with water use.	Change Flush Interval/reprogram time. Unplug unit and plug in at a time of lower water usage.
Water splashes at drain during flush.	Drain line not positioned properly.	Reposition the end of the drain line.
Water leaks at the ends of the Filter Cartridge after changing cartridges.	Cartridge end connections are not tight enough.	Tighten with strap wrench if necessary.
	O-rings not lubricated.	Lubricate O-rings with food-grade lubricant.
	O-rings are split, cut, or twisted	Replace O-rings.
Water leaks from Permeate port.	Permeate port is not tight enough	Tighten, with strap wrench if necessary.
	O-ring not lubricated.	Lubricate O-ring with food-grade lubricant.
	O-ring split, cut, or twisted.	Replace O-ring.
Water leaks from system fitting or connection.	Fitting broken or loose.	Retighten or replace the fitting.
	Not enough pipe thread sealant used.	Redo the fitting with the proper amount of sealant.

WIRING DIAGRAM

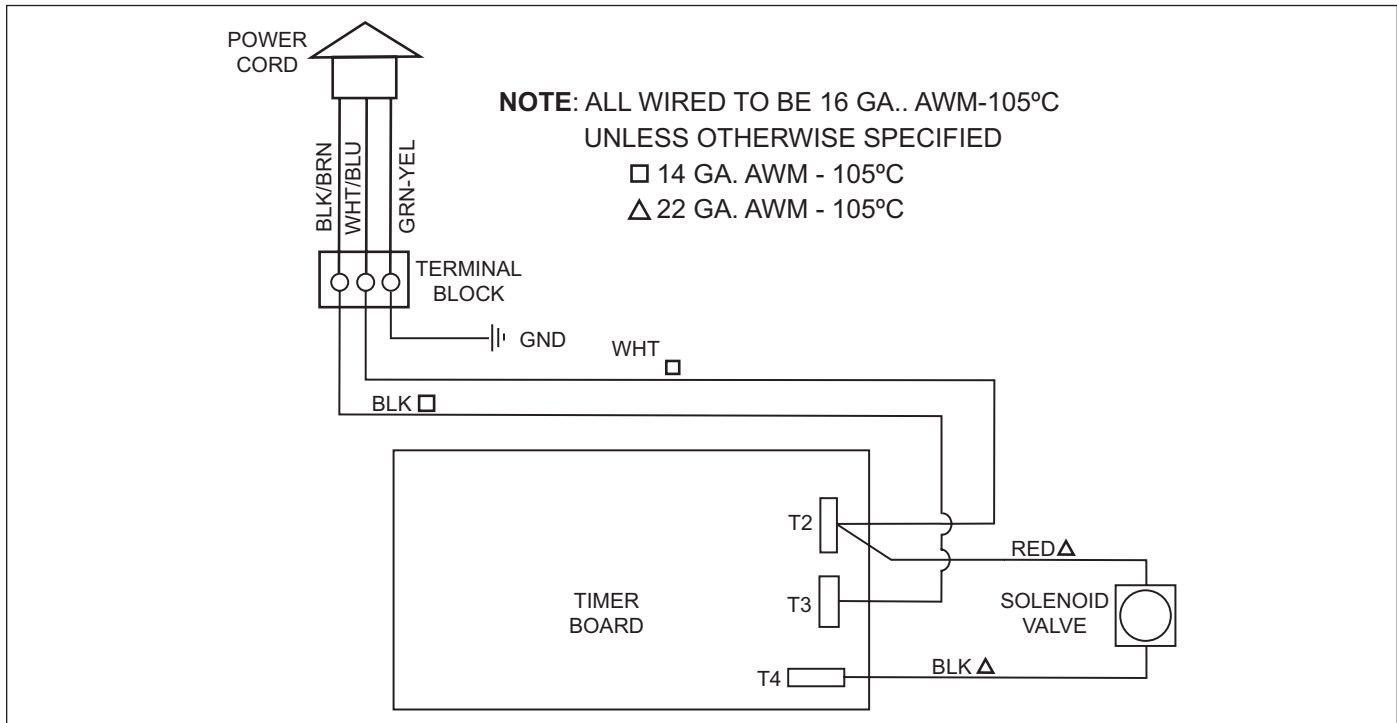

REPLACEMENT PARTS UF-420/440

Item No.	Part No.	Description	Qty.
1	7000432	Timer, 120V (For Mfg. #s 9700440 & 9700450)	1
	7000433	Timer, 230V (For Mfg. #s 9700442 & 9700452)	1
2	1001116	Label, Timer	1
3	0700463	Power Cord 5-15P (CF) (For models 9700440 & 9700450)	1
	0700634	Power Cord CEE 7/7 (HC) (For Mfg. #s 9700442 & 9700452)	1
	0700354	Power Cord Chinese/Australian, 10 Amp., 250 VAC. (Assembly only) (for Mfg. # 9700443 & 9700453 only)	1
4	040K251	Strain Relief, Power Cord	1
5	4060355	Terminal Block	1
6	0503983	Control Housing	1
7	7000359	Cover Gasket Kit	1
8	7000362	Cover, Control Housing Kit (Incl. Items 2 & 7)	1
9	4040173	Solenoid Valve 120V NC 3/4" NPT (For Mfg. #s 9700440 & 9700450)	1
	4040174	Solenoid Valve 230V NC 3/4" NPT (For Mfg. #s 9700442 & 9700452)	1
10	7000357	Solenoid Valve/Coil Kit 120 V (For Mfg. #s 9700440 & 9700450)	1

Item No.	Part No.	Description	Qty.
	7000358	Solenoid Valve/Coil Kit 230V (For Mfg. #s 9700442 & 9700452)	1
13	0504034	Clamp, Filter 4"	1
14	0504033	Mounting Bracket 4"	1
15	2090122	Cartridge, Filter 4" x 20" (For Mfg. #s 9700440 and 9700442)	1
	2090123	Cartridge, Filter 4" x 40" (For Mfg. #s 9700450 and 9700452)	1
16	0011911	Connector, End Cap 4"	2
17	2180177	Cap, End 2"	2
18	0200224	"O" Ring 4"	2
19	2190134	Tee Strainer 3/4" NPT	1
20	2090133	Screen, Tee Strainer 3/4" NPT	1
21	0200223	Gasket, Tee Strainer 3/4" NPT	1
22	2070117	Close Nipple 3/4" NPT	1
23	2190126	90° Elbow 3/4" NPT	1
24	2190141	Union 3/4"	1
25	2190131	Adaptor 1.25" to 3/4"	1
26	7000361	Strain Relief Kit	1
28	1001101	Label - Wiring Diagram	1
29	308P157	Screw Tap #8-32 x 3/8"	12
30	308P143	Nut Keps #8-32	2
31	306P101	Nut Hex #6-32	2
32	304P105	Nut Keps #4-40	4
33	308P124	One Way Screw #8-32	1
34	06P123	Screw #6-32 x 7/8"	2

REPLACEMENT PARTS UF-420/440 (continued)

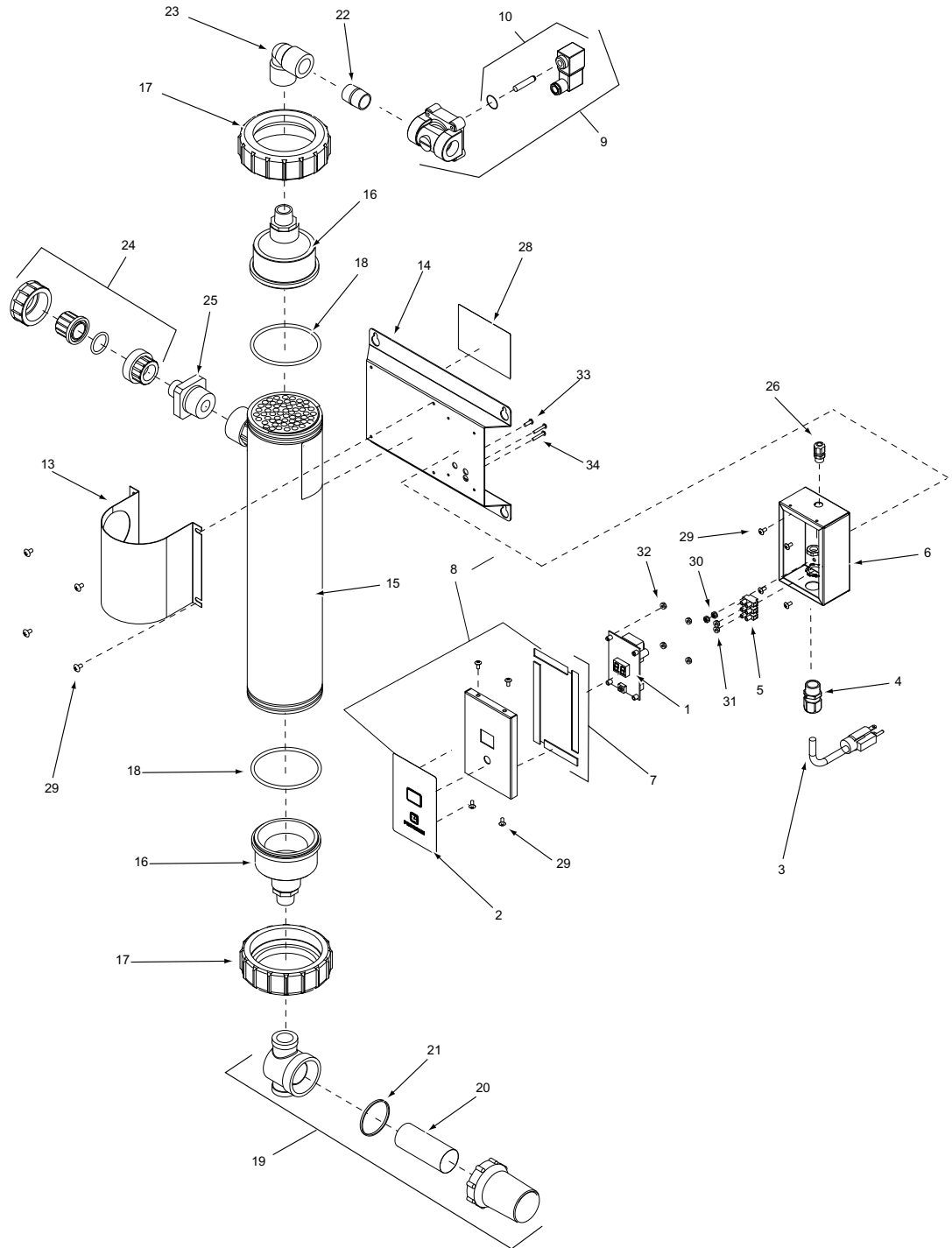

LIMITED WARRANTY

Equipment manufactured by A.J. Antunes & Co. has been constructed of the finest materials available and manufactured to high quality standards. These units are warranted to be free from defects in materials and workmanship for a period of one year from date of purchase under normal use and service, and when installed in accordance with manufacturer's recommendations*. The ultra filtration membrane cartridge is warranted under the same terms and conditions on a prorated basis for 24 months from date of purchase.

*To ensure continued proper operation of the units, follow the maintenance procedure outlined in the Owner's Manual.

1. This warranty does not cover failures due to improper system installation, defects caused by improper storage or handling prior to placing of the equipment into service. This warranty does not include overtime charges or work done by unauthorized service agencies or personnel. This warranty does not cover normal maintenance, calibration, or regular adjustments as specified in operating and maintenance instructions of this manual, and/or labor involved in moving adjacent objects to gain access to the Equipment.
2. A.J. Antunes & Co. reserves the right to make changes in design or add any improvements on any product. The right is always reserved to modify equipment because of factors beyond our control and government regulations. Changes to update equipment do not constitute a warranty charge.
3. **If shipment is damaged in transit, the purchaser should make a claim directly upon the carrier. Careful inspection should be made of the shipment as soon as it arrives and visible damage should be noted upon the carrier's documentation. Damage should be reported to the carrier. This damage is not covered under this warranty.**
4. THIS WARRANTY IS EXCLUSIVE AND IS IN LIEU OF ALL OTHER WARRANTIES, EXPRESSED OR IMPLIED, INCLUDING ANY IMPLIED WARRANTY OR MERCHANTABILITY OR FITNESS FOR A PARTICULAR PURPOSE, EACH OF WHICH IS HEREBY EXPRESSLY DISCLAIMED. THE REMEDIES DESCRIBED ABOVE ARE EXCLUSIVE AND IN NO EVENT SHALL A.J. ANTUNES & CO. BE LIABLE FOR SPECIAL CONSEQUENTIAL OR INCIDENTAL DAMAGES FOR THE BREACH OR DELAY IN PERFORMANCE OF THIS WARRANTY.

Prices and specifications are subject to change without notice.



A.J. Antunes & Co.
We exist to make our customers successful.

A.J. Antunes & Co.
Headquarters/Manufacturing
Carol Stream, Illinois 60188 USA
Phone: (630) 784-1000
Toll Free: (800) 253-2991
Fax: (630) 784-1650

Antunes Equipment
Manufacturing (Suzhou) Ltd.,
Suzhou, Jiangsu, China 215011
Phone: 86-512-6841-3637
Toll Free: 400-0-7878-22
Fax: 86-512-6841-3907

www.ajantunes.com