

Place this manual in the Small Equipment/Miscellaneous section of your Equipment Manual.

**Manufactured exclusively for  
McDONALD'S®**

**BY  
A.J. ANTUNES & CO.  
180 KEHOE BLVD.  
CAROL STREAM, ILLINOIS 60188, U.S.A.  
PHONE: 1-630-784-1000  
TOLL FREE: 1-877-392-7854  
FAX: 1-630-784-1650  
www.ajantunes.com**



MEC-600

MEC-1200

**TABLE OF CONTENTS**

<b>Owner Information .....</b>	<b>2</b>	<b>Operation.....</b>	<b>7</b>
General.....	2	Preparing Unit.....	7
Warranty Information .....	2	Egg Cooking Procedure .....	7
Service/Technical Assistance .....	2	Bacon Timer* .....	8
<b>Important Safety Information .....</b>	<b>3</b>	<b>Maintenance.....</b>	<b>9</b>
<b>Specifications .....</b>	<b>4</b>	Daily Cleaning .....	9
Electrical Ratings.....	4	Checking Cycle Times (Monthly).....	9
Shipping Weight .....	4	Checking Grill Platen Temperature.....	10
Electrical Cord & Plug Configurations .....	4	<b>Troubleshooting .....</b>	<b>11</b>
Net Weight.....	4	Control Board LEDs .....	12
Dimensions .....	5	Green LED Blink Codes .....	12
<b>Installation.....</b>	<b>6</b>	<b>Wiring Diagram.....</b>	<b>13</b>
Unpacking.....	6	<b>Replacement Parts .....</b>	<b>14</b>
Equipment Setup .....	6	<b>NOTES .....</b>	<b>16</b>

**LIMITED WARRANTY**

The Antunes Food Service Equipment Division of A.J. Antunes & Co. provides the following limited warranty to the original purchaser of all McDonald's Equipment. All components are warranted against defects in the material and workmanship for a period of two (2) years from date of original installation, not to exceed 30 months from date of shipment from our factory.

If any part becomes inoperable during the first two (2) years after the original installation date, Antunes Food Service will pay negotiated straight time labor costs to an Authorized Service Agent to replace the part, plus travel expenses up to 50 miles/80 km, 1 hour each way (100 miles/160 km, 2 hours round trip).

Antunes Food Service reserves the right to make changes in design or add improvements on any products. The right is always reserved to modify Equipment

**WARRANTY EXCLUSIONS**

- The cost of Installation.
- Equipment that has been damaged due to shipment. Purchaser should make damage claim directly upon carrier.
- Alteration, misuse, abuse.
- Improper storage or handling.
- Improper maintenance.
- Failure to follow proper Installation instructions, including electrical connection.
- Improper or unauthorized repairs.

- Scheduled Maintenance procedures as outlined in your MRC Card.
- Consumables such as Grill Covers (Release Sheets), gaskets, Conveyor Belt Wraps, O-Rings, and light bulbs.
- Overtime or Holiday charges.
- Mileage over 50 miles/80 km (100 miles/160 km round-trip), or travel time over two (2) hours.
- Freight, foreign, excise, municipal or other sales or use taxes.
- Consequential damages such as loss of profit, loss of time, the cost of repairing or replacing other property which is damaged, or any other incidental damage of any kind.

because of factors beyond our control and government regulation. Changes to Equipment do not constitute a warranty charge.

This warranty is exclusive and is in lieu of all other warranties, expressed or implied, including any implied warranty of merchantability or fitness for a particular purpose, each of which is expressly disclaimed. The remedies described above are exclusive, and in no event shall A.J. Antunes & Co. or any of its Divisions be liable for special consequential or incidental damages for the breach or delay in the performance of this warranty.

This manual is for the exclusive use of licensees and employees of McDonald's Systems, Inc.. © McDonald's Corporation All Rights Reserved

## OWNER INFORMATION

### General

This product cooks/steams a maximum of six or twelve eggs (refrigerated) in approximately 150 seconds. Eggs, within the Egg Rings, are cooked with a combination of heat and steam. With the cover closed, water is poured into a trough on the cover and drips onto a hot Platen producing steam, cooking the eggs and heating the Canadian Bacon for the "Egg McMuffin Sandwich."

The unit is equipped with audio/visual signals for operation.

This manual provides the safety, installation and operating procedures. We recommend that all information contained in this manual be read prior to installing and operating the unit.

Your MEC-600/1200 is manufactured from the finest materials available, assembled to Roundup's strict quality standards, and tested at the factory to ensure dependable trouble-free operation.

### Warranty Information

**Please read the full text of the Limited Warranty printed on the front cover of this manual.**

**If the unit arrives damaged, contact the carrier immediately and file a damage claim with them. Save all packing materials when filing a claim. Freight damage claims are the responsibility of the purchaser and not covered under warranty.**

The warranty **does not** extend to:

- Damages caused in shipment or damage as result of improper use.
- Installation of electrical service.
- Installation, calibration, or adjustment.
- Normal maintenance outlined in this manual.
- Consumable parts such as Egg Rings, gaskets, rubber feet, labels, O-rings, light bulbs, etc.
- Malfunction resulting from improper service or maintenance.
- Damage caused by improper installation, abuse, or careless handling.

- Damage from moisture getting into electrical components.
- Damage from tampering with, removal of, or changing any preset control or safety device.
- Damage caused by parts or components not provided by A.J. Antunes & Co.

### Service/Technical Assistance

If you experience any problems with the installation or operation of your unit, contact your local A.J. Antunes Authorized Service Agency. They can be found in the service agency directory packaged with the equipment.

Fill in the information below and have it handy when calling your authorized service agency for assistance. The serial number is on the specification plate located on the side of the unit.

Purchased From: \_\_\_\_\_

Date of Purchase: \_\_\_\_\_

Model No.: \_\_\_\_\_

Serial No.: \_\_\_\_\_

Mfg. No.: \_\_\_\_\_

Refer to the service agency directory and fill in the closest Authorized Service Agency information below:

Authorized Service Agency

Name: \_\_\_\_\_

Phone No: \_\_\_\_\_

Address: \_\_\_\_\_

Use only genuine A.J. Antunes replacement parts in this unit. Use of replacement parts other than those supplied by the manufacturer will void the warranty. Your Authorized Service Agency has been factory trained and has a complete supply of parts for this unit.

You may contact the factory at **1-877-392-7854, (toll free in the U.S.A.) or 630-784-1000** if you have trouble locating your local authorized service agency or need technical assistance.

**IMPORTANT! Keep these instructions for future reference. If the unit changes ownership, be sure this manual accompanies the equipment.**

### IMPORTANT SAFETY INFORMATION

Throughout this manual, you will find the following safety words and symbols that signify important safety issues with regards to operating or maintaining the equipment.

#### **WARNING**

**GENERAL WARNING.** Indicates information important to the proper operation of the equipment. Failure to observe may result in damage to the equipment and/or severe bodily injury or death.

#### **WARNING**

**ELECTRICAL WARNING.** Indicates information relating to possible shock hazard. Failure to observe may result in damage to the equipment and/or severe bodily injury or death.

#### **CAUTION**

**GENERAL CAUTION.** Indicates information important to the proper operation of the equipment. Failure to observe may result in damage to the equipment.

#### **WARNING**

**HOT SURFACE WARNING.** Indicates information important to the handling of equipment and parts. Failure to observe caution could result in personal injury.

In addition to the warnings and cautions in this manual, use the following guidelines for safe operation of the unit.

- Read all instructions before using equipment.
- Install or locate the equipment only for its intended use as described in this manual.
- Do not use corrosive chemicals in this equipment.
- Do not operate this equipment if it has a damaged cord or plug; if it is not working properly, or if it has been damaged or dropped.
- This equipment should be serviced by qualified personnel only. Contact the nearest Roundup authorized service facility for adjustment or repair.
- Do not block or cover any openings on the unit.
- Do not immerse cord or plug in water.
- Keep cord away from heated surfaces.
- Do not allow cord to hang over edge of table or counter.

The following warnings and cautions appear throughout this manual and should be carefully observed.

- Turn the unit off, disconnect the power source and allow unit to cool down before performing any service or maintenance on the unit.
- The procedures in this chapter may include the use of chemical products. These chemical products will be highlighted with bold face letters followed by the abbreviated HCS (Hazard Communication Standard). See your Hazard Communication Standard manual for the appropriate Material Safety Data Sheets (MSDS).
- The equipment should be grounded according to local electrical codes to prevent the possibility of electrical shock. This requires a grounded receptacle with separate electrical lines to be protected by fuse(s) or circuit breaker(s) of the proper rating.
- All electrical service connections must be in accordance with local and/or other applicable electrical codes.
- Do not clean this appliance with a water jet.
- Do not use a sanitizing solution or abrasive materials. The use of these may cause damage to the stainless steel finish.

**SPECIFICATIONS**

**⚠ CAUTION ⚠**

All electrical connections must be in accordance with local electrical codes and any other applicable codes.

- Chlorides or phosphates in cleansing agents (e.g. bleach, sanitizers, degreasers or detergents) could cause permanent damage to stainless steel equipment. The damage is usually in the form of discoloration, dulling of metal surface finish, pits, voids, holes or cracks. This damage is permanent and not covered by warranty:

The following tips are recommended for maintenance of your stainless steel equipment,

- Always use soft, damp cloth for cleaning, rinse with clear water and wipe dry. When required, always rub in direction of metal polish lines.
- Finger marks and smears should be rubbed off using soap and water.
- Hard water spots should be sponged using a vinegar solution.

**Electrical Ratings**

Model Number	Mfg. Number	Volts	Watts	Amp	Hertz
MEC-1200HI	9300561	230	2900	12.6	50/60
MEC-600HI	9300550	230	2900	12.6	50/60
MEC-600HC	9300552	230	2900	12.6	50/60
MEC-600HB	9300554	230	2900	12.6	50/60
MEC-1200HI	9300560	230	2900	12.6	50/60
MEC-600HI	9300548	230	2900	12.6	50/60
MEC-1200HC	9300562	230	2900	12.6	50/60
MEC-1200HB	9300564	230	2900	12.6	50/60
MEC-600HI	9300551	230	2900	12.6	50/60

**Electrical Cord & Plug Configurations**

Model & Mfg. No.	Description	Configuration
MEC-600HB 9300554 MEC-1200HB 9300564	Marechal, Pin & Sleeve, 32 Amp, 250 VAC (Australia) (Assembly Only)	
MEC-600HC 9300552 MEC1200HC 9300562	CEE 7/7, 16 Amp., 250 VAC (Assembly Only).	
MEC-600HI 9300550 MEC-1200HI 9300560	IEC-309, 16 Amp., 250 VAC., Pin & Sleeve (Assembly Only).	
MEC-600HI 9300548 MEC-1200HI 9300561	IEC-309 230 VAC Non-Molded Plug (China Only)	
MEC-600HI 9300551	IEC 309-Plug, 32 Amp., 230 VAC Three pin.	

**Shipping Weight**

- MEC-600: 48 lbs (21.7 kg)
- MEC-1200: 50 lbs (22.6 kg)

**Net Weight**

- MEC-600: 41 lbs (18.6 kg)
- MEC-1200: 43 lbs (19.5 kg)

**IMPORTANT!** A.J. Antunes & Co. reserves the right to change specifications and product design without notice. Such revisions do not entitle the buyer to corresponding changes, improvements, additions or replacements for previously purchased equipment.

### SPECIFICATIONS (continued)

#### Dimensions

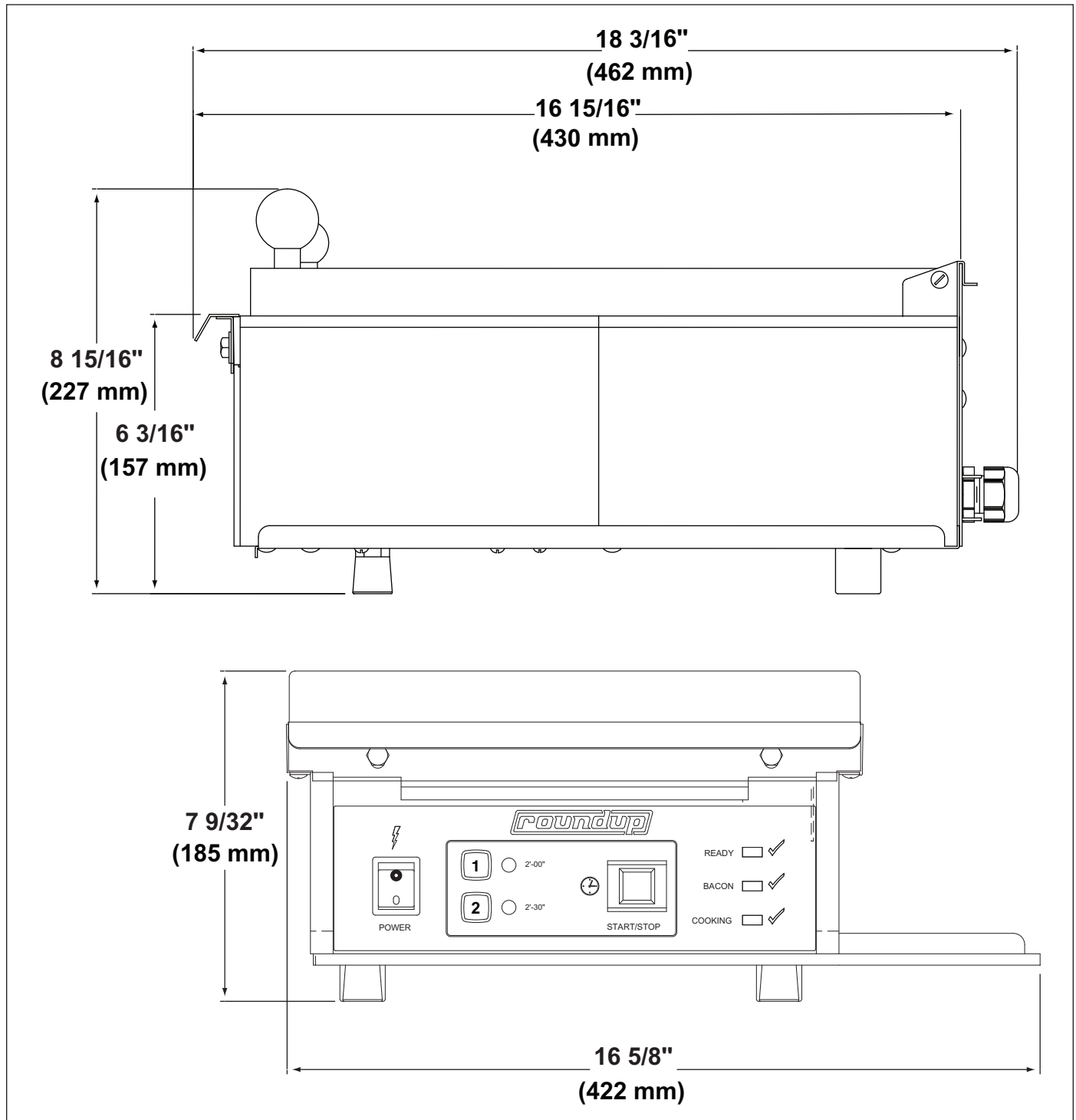

**INSTALLATION**

**Unpacking**

1. Remove unit and all packing materials from shipping carton.

**NOTE: If any parts are missing or damaged, contact Antunes Technical Service IMMEDIATELY at 1-877-392-7854 (Toll free in the U.S. and Canada) or 630-784-1000.)**

2. Remove information packet.
3. Remove all packing materials and protective coverings from the unit.
4. Wipe all surfaces of the unit with a hot damp cloth.

**NOTE: Do not use a dripping wet cloth. Wring it out before use.**

5. Clean the Egg Rings, Egg Rack, cover and service pans in hot, soapy water. Rinse in clear water and allow to air dry.
6. Reassemble all parts to unit.

**Equipment Setup**

When placing the unit into service, pay attention to the following guidelines:

- Make sure power to the unit is off and the unit is at room temperature.
- Do not block or cover any openings on the unit.
- Do not immerse cord or plug in water.
- Keep cord away from heated surfaces.
- Do not allow cord to hang over edge of table or counter.
- Place the unit on a sturdy, level table or other work surface. Turn off the Rocker Switch (power On/Off) before proceeding.
- **Ensure that the line voltage corresponds to the stated voltage on the unit's specification label. If unsure, have an electrician confirm correct line voltage before connecting unit.**

**⚠ CAUTION ⚠**

All electrical service connections must be in accordance with local electrical codes and any other applicable codes.

**⚠ IMPORTANT ⚠**

When installing the unit, use a leveler to ensure that the table/cart is level and that the unit is level when placed. If necessary, adjust the two front bottom legs of the unit to level it. Failure to level the table and/or unit may result in unevenly cooked product.

**⚠ WARNING ⚠**

**ELECTRICAL SHOCK HAZARD.**

**FAILURE TO FOLLOW THE INSTRUCTIONS IN THIS MANUAL COULD RESULT IN SERIOUS INJURY OR DEATH.**

- Electrical ground is required on this appliance.
- Do not modify the power supply cord plug. If it does not fit the outlet, have a proper outlet installed by a qualified electrician.
- Do not use an extension cord with this appliance.
- The unit should be grounded according to local electrical codes to prevent the possibility of electrical shock. It requires a grounded receptacle with separate electrical lines, protected by fuses or circuit breaker of the proper rating.
- Check with a qualified electrician if you are in doubt as to whether the appliance is properly grounded.

## OPERATION

### Preparing Unit

1. Turn the Rocker Switch (power On/Off) to ON (Figure 2).
2. Place Egg Ring into Egg Rack (Figure 3).
3. Vertically place the pins of the Egg Rack into the slots that are attached to the cover.
4. Check to see that all Egg Rings are seated flat on the Platen surface.
5. Ensure that the Egg Rack and cover are in the down position while the cooker warms up.
6. Put melted butter (or equivalent) in one Service Pan (if desired) and slide Service Pan into tray on right side of unit.
7. Slide second Service Pan into tray for use as Platen scrapings collector (if desired).
8. Allow the unit to preheat for approximately 20-30 minutes.

**NOTE: The Ready Indicator Light will flash while the unit is heating up and will stay on after the unit reaches operating temperature.**

### Egg Cooking Procedure

Read these instructions prior to cooking eggs.

1. Ensure that the unit is set on a level surface.
2. Verify that the unit itself is level so that water does not run from one side to the other. Adjust the legs as needed to level the unit.

3. Make sure the grill is clean and free of all extra butter, oils, or egg product.
4. Raise the Top Cover and brush the Egg Rings and Grill surface with melted butter or equivalent.
5. Crack the eggs into the Egg Rings from right to left as shown in Figure 1 below, starting at the row closest to the front of the unit.

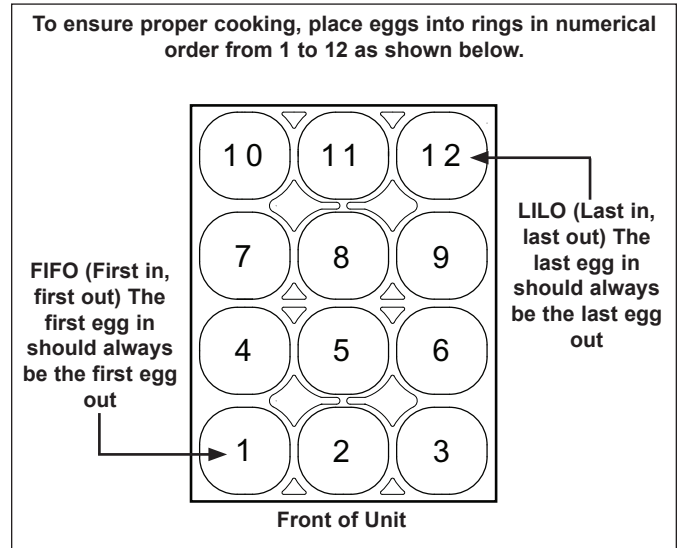

Figure 1. Egg Cooking Procedure

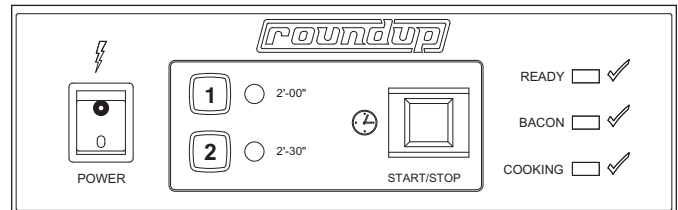

Figure 2. Operating Controls

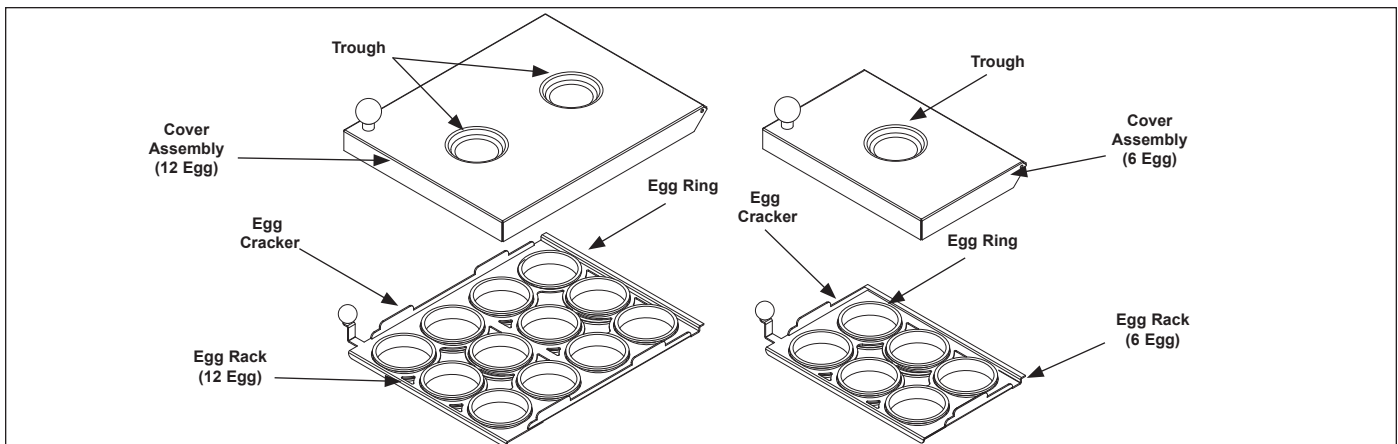

Figure 3. Cover Assembly (12 and 6 Egg)

**OPERATION (continued)**

6. Continue to crack the eggs, placing them in order, until all six Egg Rings (or 12 shown above) contain an egg.
7. Break the egg yolks with the yellow Hutzler flat spatula.
8. Close the Top Cover.
9. Fill the two troughs on the Top Cover with warm water until they are **completely full**. This is very important to get a completely cooked egg with a jelled yolk. Using less water results in under-cooked eggs.
10. Select the 2 (two) minute cycle for room temperature eggs or the 2.5 (two and a half) minute cycle for refrigerated eggs.
11. Press the Start/Stop button to initiate the cooking cycle.

**NOTE: The cooking indicator light will light when the Start/Stop switch is pressed and released.**

12. **MEC-600 units only:** If desired, place sliced meat (Canadian bacon, ham, etc.) on front part of Platen when "Bacon" indicator light begins to flash and the audio signal sounds (see **Bacon Timer** in the Operation section of this manual).
13. At the end of the cycle, when the "Cooking" indicator light turns off and the audio signal sounds, press the "Start/Stop" switch to turn off the audio signal.
14. **All MEC units:** Open the cover and raise the Egg Rack about 1 inch (26 mm), then drop the rack to loosen the eggs.
15. Raise the Egg Rack completely off the eggs and remove the eggs starting with the **FIRST** egg added (far right of the first row of rings closest to the front of the unit) (Figure 1). Continue removing the eggs in the order they were added until all eggs have been removed.
16. Use the scraper provided to clean the Grill surface and move waste into the Service Pan.
17. Lower the Egg Rack and Top Cover. The unit is ready for further cooking.

**Bacon Timer\***

If, during the standby mode, the blue Bacon LED light is not lit, it means that the Bacon Timer is disabled. To enable the Bacon timer, with the unit turned on, press the Time 1 and Time 2 buttons simultaneously for 3 or more seconds. The blue Bacon LED light will light up. The Bacon Timer is now enabled.

To disable the Bacon Timer, press the Time 1 and Time 2 buttons simultaneously for 3 or more seconds. The blue Bacon LED light will turn off. The Bacon Timer is now disabled.

If the Bacon Timer is enabled, an audio signal will sound for a few seconds and the blue Bacon LED light will begin to flash 30 seconds before the end of the Cooking cycle. During this time, the product should be placed on the front part of the grill so that it will heat for 30 seconds. The Bacon LED light will continue to flash until the end of the cooking cycle.

\*MEC-600 units are designed to operate with the Bacon Timer enabled.

MEC-1200 units are designed to operate with the Bacon Timer disabled.

### MAINTENANCE

#### ⚠ WARNING ⚠

Turn the unit off, disconnect the power source and allow the unit to cool down before performing any service or maintenance on the unit.

#### ⚠ CAUTION ⚠

Chlorides or phosphates in cleansing agents (e.g. bleach, sanitizers, degreasers or detergents) could cause permanent damage to stainless steel equipment. The damage is usually in the form of discoloration, dulling of metal surface finish, pits, voids, holes or cracks. This damage is permanent and not covered by warranty. The following tips are recommended for maintenance of your stainless steel equipment:

- Always use soft, damp cloth for cleaning, rinse with clear water and wipe dry. When required, always rub in direction of metal polish lines.
- Stains and spots should be sponged using a vinegar solution.
- Finger marks and smears should be rubbed off using soap and water.
- Hard water spots should be sponged using a vinegar solution.

#### ⚠ CAUTION ⚠

Do not use a sanitizing solution or abrasive materials. The use of these may cause damage to the stainless steel finish.

#### ⚠ CAUTION ⚠

If a chemical cleaner is used, be sure it is safe to use on cast aluminum. Observe all precautions and warnings on product label.

### Daily Cleaning

1. Turn the Rocker Switch (Power On/Off) to OFF, unplug the power cord, and allow the unit to cool down.
2. Remove the Top Cover, Egg Rings, and Service Pans.
3. Clean the Top Cover, Egg Rings, and Service Pans in hot detergent water. Rinse in sanitized water and allow to air dry.
4. If needed, apply McD® Grill Cleaner (HCS) according to the instructions on the container. Using the grill cloth, wipe the unit in a back to front motion. Use a fresh grill cloth and rinse the grill surface with water to remove all traces of the grill cleaner.
5. Spray McD® All-Purpose Super Concentrate (APSC) (HCS) onto a clean, dry towel and clean the entire unit. Use a clean, dry towel to wipe the unit dry.
6. Reinstall the Top Cover, Egg Rings, and Service Pans. Plug the power cord into the appropriate outlet.

### Checking Cycle Times (Monthly)

**CAUTION: Grill surfaces will be hot. Care should be taken when operating this piece of equipment.**

**NOTE: A stopwatch is required for this procedure.**

1. Turn the Rocker Switch (power On/Off) to ON. Allow the unit to preheat for 30 minutes.
2. Ensure that the #1 Time Selector Button (2'-00") is lit. If not, press and release the #1 button. This button should now be lit.
3. With the stopwatch in hand, press and release the Start/Stop cycle switch and start the stopwatch.
4. Record the time when the Bacon light begins to flash (if the Bacon Timer is enabled). Then, record the time when the Cooking light turns off.

**MAINTENANCE (continued)**

5. Repeat this test with the Time Selector button set at 2'-30".

When set at 2'-00", the Bacon light should flash at 1 minute and 30 seconds (90 seconds), and the Cooking light should turn off at 2 minutes (120 seconds).

When set at 2'-30", the Bacon light should flash at 2 minutes (120 seconds), and the Cooking light should turn off at 2 minutes and 30 seconds (150 seconds).

All times are to be within +/- five (5) seconds.

6. Turn the Rocker Switch (Power On/Off) to OFF.

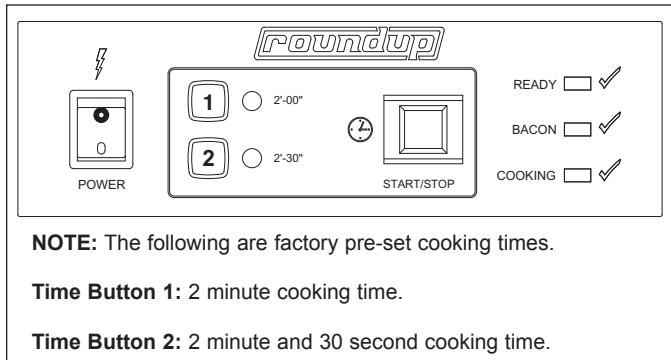

**Figure 4. Time Selector Switch**

**Checking Grill Platen Temperature**

**NOTE:** A pyrometer is required for this procedure.

**WARNING**

**This procedure exposes you to hot surfaces. Use extreme care when performing procedure to avoid personal injury.**

1. Move the cover and the Egg Rack by lifting the whole assembly until clear of the base.
2. Turn the Rocker Switch (power On/Off) to the ON position. Allow 30 minutes for the unit temperature to stabilize.
3. Using a pyrometer, measure the temperature at the middle of the Platen surface (Figure 5). The temperature should be 250° F (121° C) to 300° F (149° C)

If temperature is within range, proceed to Step 4.

If temperature is above or below the range, call your Authorized Service Agency.

4. Turn the Rocker Switch (power On/Off) to the OFF position.
5. Reinstall cover and Egg Rack and cover.



**Figure 5. MEC-600 Shown**

### TROUBLESHOOTING

#### **⚠ WARNING ⚠**

To avoid possible personal injury and/or damage to the unit, inspection, test and repair of electrical equipment should be performed by qualified service personnel. The unit should be unplugged when servicing.

Problem	Possible Cause	Corrective Action
Unit fails to operate and control panel lights fail to signal on.	No power/low power.	Make sure Rocker Switch (power On/Off) is ON and power cord is locked into place. Check main circuit breakers.
	Inoperable electrical outlet.	Plug into different outlet of same amperage rating.
	Inoperable rocker (power On/Off) switch.	Contact your maintenance person or an Authorized Service Agency.
	Inoperable power cord.	
	Loose Connections.	
Unit fails to heat.	Loose connections.	Contact your maintenance person or an Authorized Service Agency.
	Inoperable Platen.	
	Low voltage.	
	Inoperable hi-limit thermostat.	
	Inoperable thermocouple.	
	Inoperable solid state relay.	
Eggs do not cook properly.	Using refrigerated eggs and time selector switch set for 2' 00".	Set time selector switch to 2' 30" when using refrigerated eggs.
	Time selector switch is set for 2' 30" (eggs overcooked).	Set time selector switch to 2' 00" when using room temperature eggs.
	Incorrect amount of water added to trough in cover.	Fill trough in cover with water before starting time cycle.
	Platen Temperature is too low or too high.	Check temperature according to the Maintenance section of this manual.
	Loose connections.	Contact your Authorized Service Agency.
	Unit/table is not level.	Level the table and unit as necessary.
Eggs sticking to Platen.	Dirty Platen.	Clean Platen.
	Insufficient butter being used.	See the Operating section of this manual.
Eggs sticking to Egg Rings.	Insufficient butter being used.	See the Operating section of this manual.
	Dirty Egg Rings.	Do not use an abrasive scrubbing pad to clean Egg Rings.
	Inoperable Egg Ring.	Replace Egg Ring.
Not signaling on "Bacon" or "Ready".	Inoperable indicator light or audio signal.	Contact your maintenance person or an Authorized Service Agency.
	Inoperable control board.	
	Loose connection.	
	Bacon Timer is disabled.	Enable Bacon Timer according to the Operating Section of this manual.

If the troubleshooting steps listed do not solve your problem, contact an A.J. Antunes Authorized Service Agency for further assistance.

**TROUBLESHOOTING (continued)**

**Control Board LEDs**

The Control Board has three on board LEDs (Figure 6) to determine the status of the unit and to assist in troubleshooting.

**Green (Diagnostic):** This LED should be off in normal operation, however if any of the 5 potential faults are detected by the Control Board, this LED will repeatedly blink 1 through 5 times with a 2 second pause in between. See **Green LED Blink Codes** below.

**Yellow (Audio):** When lit, this LED indicates that the Control Board is supplying approximately 10-15 VDC to the audio signal. The audio signal should sound when this LED is lit.

**Red (Heat):** When lit, this LED indicates that the Control Board is calling for heat by supplying VDC to terminals 3(+) and 4(-) of the Solid State Relay. When off, it means that the grill platen is up to operating temperature and satisfied.

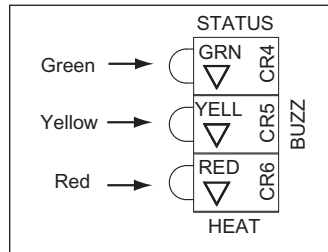

**Figure 6. Control Board LEDs**

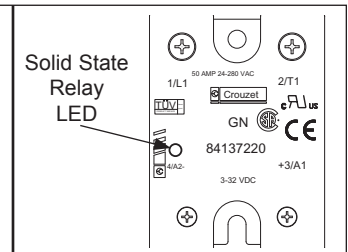

**Figure 7. Solid State Relay**

**NOTE:** During heat mode, this Red LED is very dim, so it may be difficult to verify if the Control Board is, or is not, calling for heat. It is recommended that you observe the small round green LED on the Solid State Relay (Figure 7) for mode and diagnostic purposes. When the green LED on the Solid State Relay is on, it means that the Control Board is calling for heat. When off, it means that the Control Board is NOT calling for heat.

**Green LED Blink Codes**

Number of Blinks	Cause(s)	Unit's State
The Green LED blinks on and off 1 time, pauses for 2 seconds, and repeats.	The EEPROM memory on the Control Board is corrupted.	In this state, the unit turns off the control signal to the Solid State Relay and disables all front buttons and lights. The unit will not heat up. This continues until the defaults are reloaded into memory. To reload the defaults, turn the unit off, press and hold the Time 2 button, turn the unit back on, and release the button.
The Green LED blinks on and off 2 times, pauses for 2 seconds, and repeats.	The ambient temperature within the control compartment has exceeded 155° F (68 C). Verify that there is proper air ventilation around the unit and that it is not near a significant heat source.	In this state, the unit turns off the control signal to the Solid State Relay and disables all front buttons and lights. The unit will not heat up. This continues until the ambient temperature drops below 140° F (60° C) and the unit is turned off and back on.
The Green LED blinks on and off 3 times, pauses for 2 seconds, and repeats.	Open or disconnected Thermocouple.	In this state, the unit turns off the control signal to the Solid State Relay and disables all front buttons and lights. The unit will not heat up. This continues until the Thermocouple is reconnected or replaced and the unit is turned off and back on.
The Green LED blinks on and off 4 times, pauses for 2 seconds, and repeats.	The supply voltage to the unit is below 160 VAC or above 265 VAC.	In this state, the unit turns off the control signal to the Solid State Relay and disables all front buttons and lights. The unit will not heat up. This continues until the supply voltage is within the limit and the unit is turned off and back on.
The Green LED blinks on and off 5 times, pauses for 2 seconds, and repeats.	The 50/60 Hz signal has been lost due to a loose, disconnected, or an open wire harness/wiring on the AC Isolator Board, or from the AC Isolator Board to the Control Board.	In this state, the unit turns off the control signal to the Solid State Relay and disables all front buttons and lights. The unit will not heat up. This continues until the 50/60 Hz signal is reapplied and the unit is turned off and back on.



**REPLACEMENT PARTS**

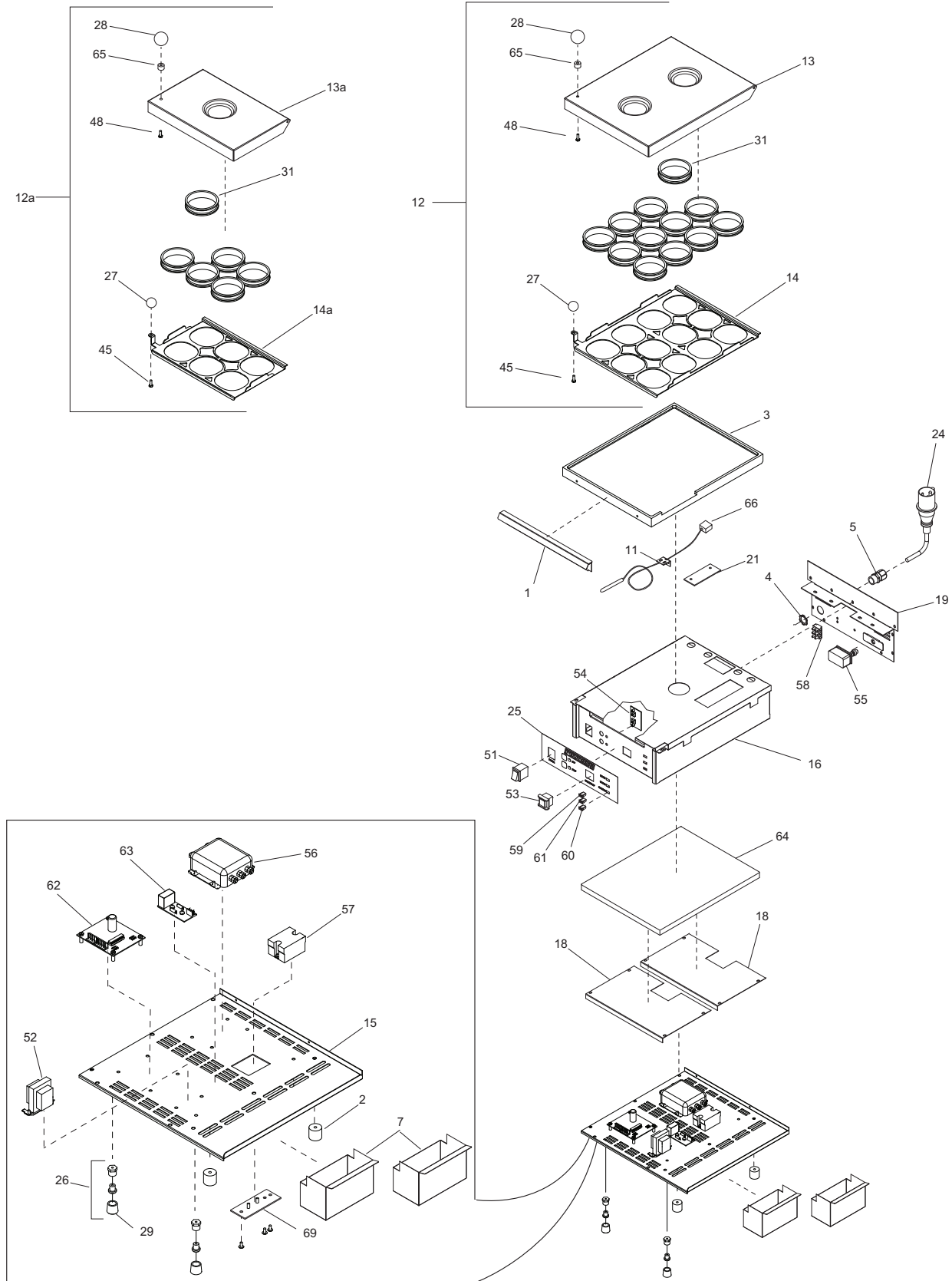

### REPLACEMENT PARTS (continued)

Item	Part No.	Description	Qty.
1	0021327	Nose Piece Weldment	1
2	210K230	Bumper, Recess Leg 1" (Set of 4 including 4 screws)	1
3	7000379	Grill Platen	1
4	040P138*	Lock-nut, Conduit - 1/2" NPT	1
5	0400315	Strain Relief - Cord Connector	1
7	0010192	Service Pan	2
11	0502900	Bracket, Sensor	1
12	7000363	Cover, Rack, & Ring Assembly	1
12a	7000261	Cover, Rack, & Ring Assembly	1
13	7000451	Cover, 12 Egg (Includes 28, 48, 65)	1
13a	7000453	Cover, 6 Egg (Includes 28, 48, & 65)	1
14	7000452	Rack, 12 Egg Ring (Includes 27 & 45)	1
14a	7000454	Rack, 6 Egg Ring (Incl. 27 & 45)	1
15	0021324	Panel, Base	1
16	0021325	Housing, Main	1
18	0504075	Cover, Insulation	2
19	0021326	Rear Panel Weldment	1
21	0504078	Bracket, Hi-Limit	1
24	0700437	Power Cord, Harmonized 16 Amp, IEC 309 (Mfg. No. 9300550 & 560)	1
	0700453	Power Cord, Harmonized 16 Amp, CEE 7/7 (Mfg. No. 9300552 & 562)	1
	0700587	Power Cord, Harmonized w/ Marechal 132 Amp. Pin & Sleeve (Mfg. No. 9300554 & 564)	1
	0700442	Power Cord Assy. Harmzd 2.5 mm cord w/ IEC-309 non-molded plug (Mfg. No. 9300548 & 561))	1
	0700588	IEC 309-Plug, 32 Amp., 230 VAC Three pin. (Mfg. No. 9300551 Only)	1
25	1001100	Label, Control	1
26	210K122	Adj. Leg Kit (4 pack)	1
27	2100137	Knob Ball	1
28	2100138	Knob-Ball	1
29	210K108	Rubber Tip Kit (4 Pack)	1
31	2130111	Egg Ring (single)	12/6
	213K101	Egg Ring (Pkg. of 6)	1/2
33	300P102*	Nut, Speed #8-32 "U"	1
37	306P113*	Screw, Mach. #6-32 x 5/8" Sltrshd	2

Item	Part No.	Description	Qty.
38	306P123*	Screw, Mach. #6-32 x 7/8" Sltrshd	4
39	306P130*	Nut, Hex KEPS #6-32	6
40	308P102*	Washer, Int. Tooth #8	1
41	308P104*	Scr, Mach #8-32 x 3/8" Sltrshd	1
42	308P143*	Nut, Hex KEPS #8-32	1
43	308P157*	Screw, Tap #8-32 x 3/8"	1
44	310P102*	Washer, Int Tooth-lock #10	2
45	310P109*	Scr, Mach #10-32 x 3/8" Sltrshd	1
46	310P136*	Scr, Mach. #10-32 x 1 and 1/4" Slpanhd	1
47	310P149*	Scr, Mach. #10-32 x 7/8" Slpanhd	1
48	325P103*	Scr, HXCAP 1/4-20 x 3/4"	1
49	325P104*	Washer, Flat 1/4" S/S	1
50	325P109*	Scr, Hxcap 1/4-20 x 3/4"	1
51	4010137	Switch, Rocker (25A-250V)	1
52	4010187	Transformer, Stepdown (240V/12)	1
53	4010190	Switch, Momentary	1
54	4010193	PC-Board, Switch-Two Button	1
55	7000272	Thermostat, Hi-Limit	1
56	4050229	Line Filter	1
57	7000370	Solid State Relay	1
58	7000136	Terminal Block, 3-Pole	1
59	4060362	LED, Snap-in (Green - Ready)	1
60	4060363	LED, Snap-in (Yellow - Cooking)	1
61	4060385	LED, Snap-in (Blue - Bacon)	1
62	7000390	Control Board	1
63	7000391	A/C Line Isolator Board	1
64	0400337	Insulation	1
65	2120111	Spacer	1
66	4050214	Thermocouple	1
67	2180111	Plastic Dispensing Bottle (not shown)	1
68	213K115	Spatula, Scraper and Brush Kit (not shown)	1
69	0011251	Heat Sink Assembly	1
70	0700648	Wire Set, Main (not shown)	1
71	0700655	Wire Harness/PCB-LEDs (not shown)	1
72	0700656	Wire Harness/PCB-Isoloator BD (not shown)	1
73	0700657	Wire Harness/PCB-2 Button Bd (not shown)	1

\* Available only packages of 10.

