

INSTALLATION INSTRUCTIONS

FOR CASED/UNCASED COILS FOR GAS AND OIL FURNACES:

(-)CFA: featuring R-22 Refrigerant

(-)CFL: featuring Earth-Friendly R-410A Refrigerant 

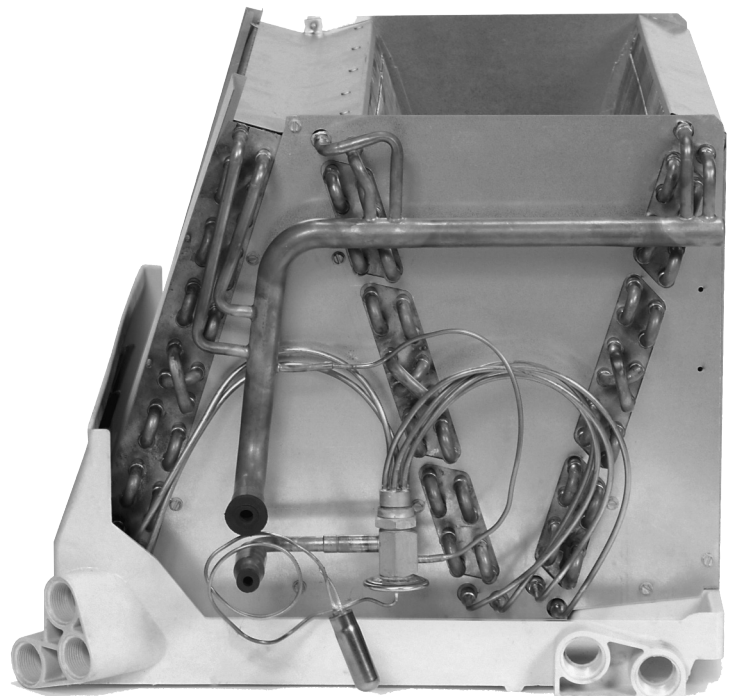

RECOGNIZE THIS SYMBOL AS AN INDICATION OF IMPORTANT SAFETY INFORMATION!

WARNING

These instructions are intended as an aid to qualified licensed service personnel for proper installation, adjustment and operation of this unit. Read these instructions thoroughly before attempting installation or operation. Failure to follow these instructions may result in improper installation, adjustment, service or maintenance possibly resulting in fire, electrical shock, property damage, personal injury or death.



ISO 9001:2000

Certificate Number: 30164

DO NOT DESTROY THIS MANUAL

PLEASE READ CAREFULLY AND KEEP IN A SAFE PLACE FOR FUTURE REFERENCE BY A SERVICEMAN

TABLE OF CONTENTS

1.0	Safety Information	3
2.0	General Information	4
2.1	Inspection	4
2.2	Codes & Regulations	4
2.3	Replacement Parts	5
2.4	Model Number Explanation	5
2.5	Coil Specifications	6
2.5A	Coil Specifications: Dimensions & Weights	6
2.5B	Coil Specifications: Airflow Pressure Drop	7
3.0	Installation	7
3.1	Applications	7
3.2	Refrigerant Connections	9
3.3	TEV Sensing Bulb	9
3.4	Condensate Drain Tubing	9
3.5	Duct Flanges	10
4.0	Maintenance	11
4.1	Air Filter	11
4.2	Indoor Coil - Drain Pan - Drain Line	11
5.0	Accessories	12
5.1	Plenum Adapter Accessory	12
5.2	Horizontal Flow Accessory	12
5.3	RXBC- Indoor Coil Casing	13

1.0 SAFETY INFORMATION

WARNING

These instructions are intended as an aid to qualified licensed service personnel for proper installation, adjustment and operation of this unit. Read these instructions thoroughly before attempting installation or operation. Failure to follow these instructions may result in improper installation, adjustment, service or maintenance possibly resulting in fire, electrical shock, property damage, personal injury or death.

WARNING

PROPOSITION 65: This appliance contains fiberglass insulation. Respirable particles of fiberglass are known to the State of California to cause cancer.

All manufacturer products meet current Federal OSHA Guidelines for safety. California Proposition 65 warnings are required for certain products, which are not covered by the OSHA standards.

California's Proposition 65 requires warnings for products sold in California that contain or produce any of over 600 listed chemicals known to the State of California to cause cancer or birth defects such as fiberglass insulation, lead in brass, and combustion products from natural gas.

All "new equipment" shipped for sale in California will have labels stating that the product contains and/or produces Proposition 65 chemicals. Although we have not changed our processes, having the same label on all our products facilitates manufacturing and shipping. We cannot always know "when, or if" products will be sold in the California market.

You may receive inquiries from customers about chemicals found in, or produced by, some of our heating and air-conditioning equipment, or found in natural gas used with some of our products. Listed below are those chemicals and substances commonly associated with similar equipment in our industry and other manufacturers.

- Glass Wool (Fiberglass) Insulation
- Carbon Monoxide (CO).
- Formaldehyde
- Benzene

More details are available at the websites for OSHA (Occupational Safety and Health Administration), at www.osha.gov and the State of California's OEHHA (Office of Environmental Health Hazard Assessment), at www.oehha.org. Consumer education is important since the chemicals and substances on the list are found in our daily lives. Most consumers are aware that products present safety and health risks, when improperly used, handled and maintained.

CAUTION

For horizontal applications, the horizontal drain pan must be located under the indoor coil. Failure to place the pan under the coil can result in property damage.

CAUTION

It is recommended that an auxiliary/secondary drain pan be installed under units containing evaporator coils that are located in any area of a structure where damage to the building or building contents may occur as a result of an overflow of the coil drain pan or a stoppage in the primary condensate drain piping.

2.0. GENERAL INFORMATION

2.1. INSPECTION

Immediately upon receipt, all cartons, and contents should be inspected for transit damage. Units with damaged cartons should be opened immediately. If damage is found, it should be noted on the delivery papers and a damage claim filed with the last carrier. Shipping damage is not covered by the warranty.

- After unit has been delivered to job site, remove carton taking care not to damage unit.
- Check the unit rating plate to be sure equipment matches what is required for the job specification.
- Read the entire instructions before starting the installation. This is particularly important if this is the first installation for this specific model series.
- Many installation steps done prior to installing the unit can save time and simplify the installation.

2.2. CODES/REGULATIONS

Units should be installed in accordance with any local or national codes which may apply. Latest editions are available from: "National Fire Protection Association, Inc., Batterymarch Park, Quincy, MA 02269."

These publications are:

- *ANSI/NFPA Latest Edition (NEC) National Electrical Code.*
- *NFPA90A Installation of Air conditioning and Ventilating Systems.*
- *NFPA90B Installation of Warm Air Heating and Air Conditioning Systems.*

2.3. REPLACEMENT PARTS

Any replacement part must be the same as or an approved alternate to the original part supplied. The manufacturer will not be responsible for replacement parts not designed to physically fit or operate within the design parameters the original parts were selected for.

When ordering replacement parts, it is necessary to order by part number and include the complete model number and serial number from the coil rating plate. (See parts list for unit component part numbers. Parts are available through the local distributor.)

2.4 MODEL NUMBER EXPLANATION

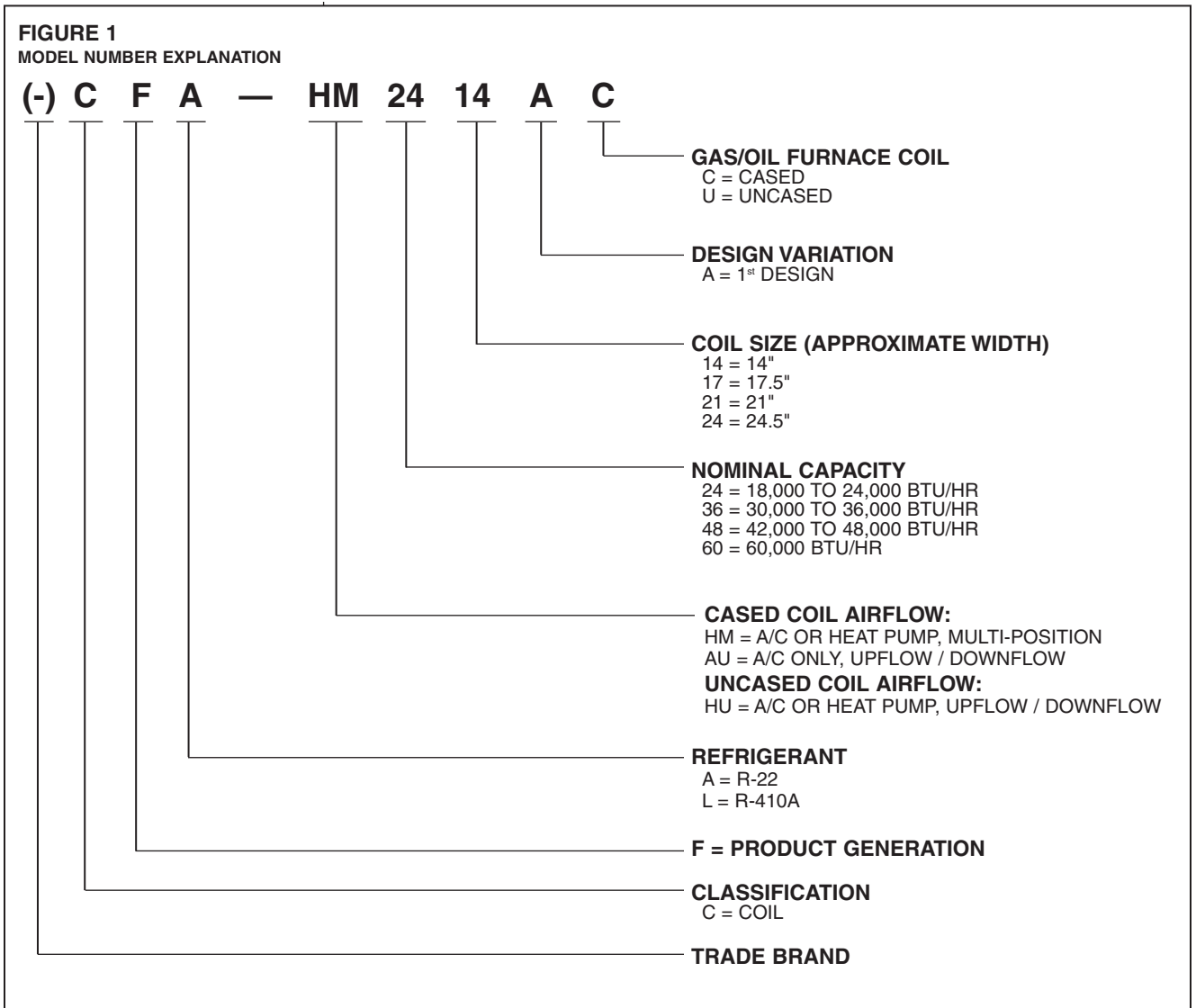

2.5 COIL SPECIFICATIONS

2.5A Coil Specifications: Dimensions & Weights (See Figure 2)

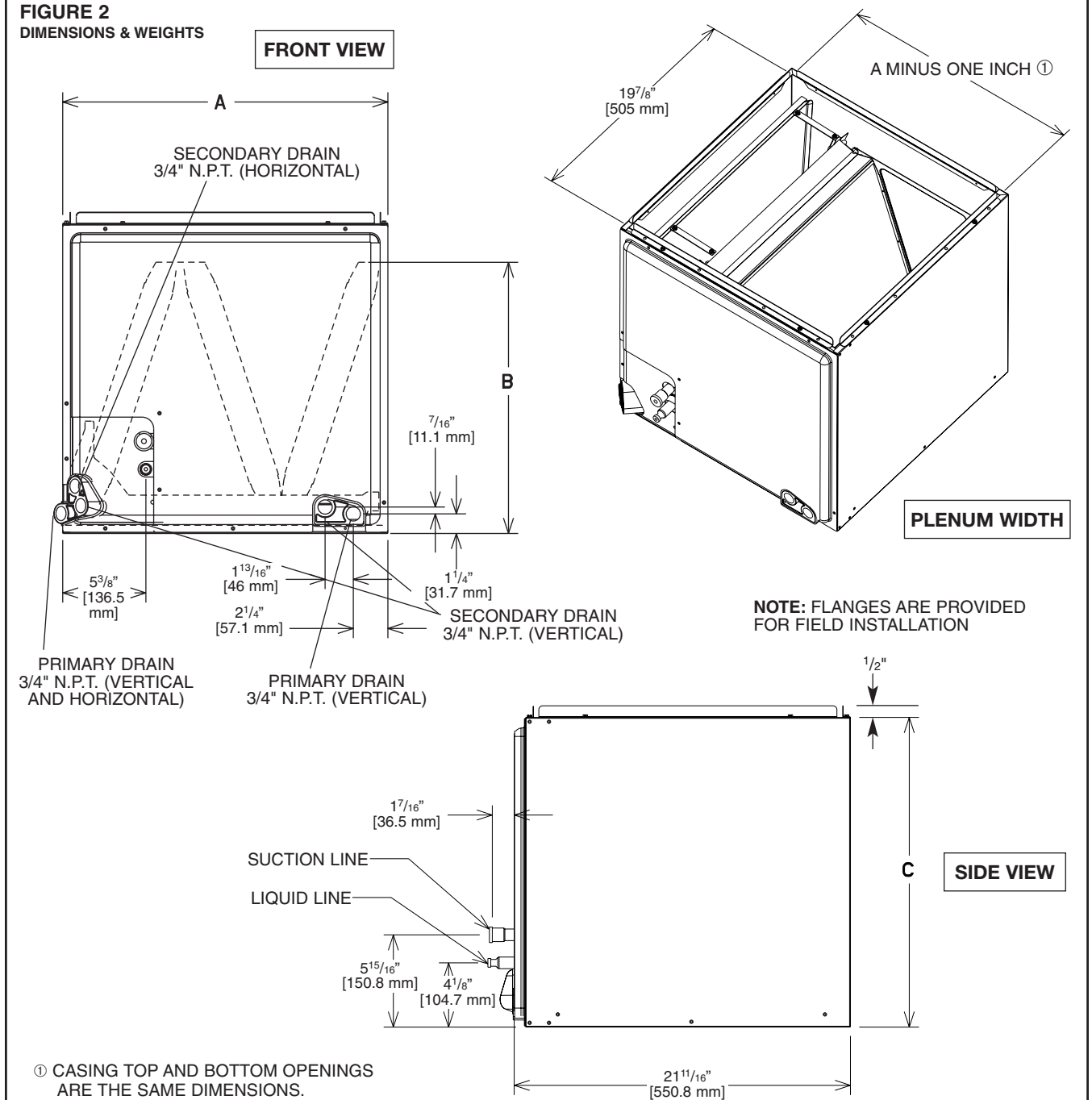

DIMENSIONS AND WEIGHTS DATA

Coil Model	Connections I.D.		Cased Coil Dimensions (in.) [mm]			Weight	
	Sweat (in) [mm]		A	B	C	Coil Weight (lbs.) [Kg]	Shipping Weight (lbs.) [Kg]
	Liquid	Suction					
2414	3/8 [9.53]	3/4 [19.05]	14 [356]	21 [533]	23 3/16 [589]	46 [21]	50 [23]
2417	3/8 [9.53]	3/4 [19.05]	17 1/2 [445]	14 1/2 [368]	20 [508]	46 [21]	51 [23]
3617	3/8 [9.53]	3/4 [19.05]	17 1/2 [445]	17 7/8 [454]	20 [508]	52 [24]	57 [26]
3621	3/8 [9.53]	3/4 [19.05]	21 [533]	17 1/2 [445]	20 [508]	54 [24]	60 [27]
4821	3/8 [9.53]	7/8 [22.23]	21 [533]	25 7/8 [657]	28 [711]	76 [34]	83 [38]
4824	3/8 [9.53]	7/8 [22.23]	24 1/2 [622]	25 3/8 [645]	32 [812]	89 [40]	99 [45]
6024	3/8 [9.53]	7/8 [22.23]	24 1/2 [622]	30 1/4 [768]	32 [812]	108 [49]	118 [54]

2.5B Coil Specifications: Airflow Pressure Drop

TABLE 1
AIRFLOW PRESSURE DROP

Coil Model	Approx. Design Air Flow CFM [L/s] Range	Face Area Sq. Ft. [m ²]	Fins-in./ Rows Deep	Static Pressure Drop Through Wet Cooling Coil [kPa] (Inches W.C.) CFM [L/s]													
				600 [283]	700 [330]	800 [378]	900 [425]	1000 [472]	1100 [519]	1200 [566]	1300 [614]	1400 [661]	1500 [708]	1600 [755]	1700 [802]	1800 [850]	1900 [897]
HIGH EFFICIENCY COOLING COILS																	
2414	600/1000 [283/472]	4.56 (0.42)	16/2	.17 [.043]	.21 [.053]	.25 [.063]	.31 [.080]	.40 [.100]	.46 [.117]	—	—	—	—	—	—	—	—
2417	600/1000 [283/472]	4.56 [0.42]	16/2	.15 [.039]	.19 [.049]	.23 [.059]	.30 [.076]	.38 [.096]	.45 [.113]	—	—	—	—	—	—	—	—
3617	900/1400 [424/661]	5.70 [0.53]	16/2	—	—	.17 [.043]	.21 [.053]	.26 [.064]	.31 [.080]	.36 [.092]	.41 [.103]	—	—	—	—	—	—
3621	900/1400 [424/661]	5.70 [0.53]	16/2	—	—	.15 [.038]	.18 [.047]	.23 [.058]	.27 [.069]	.31 [.080]	.37 [.094]	—	—	—	—	—	—
4821	1200/1800 [566/850]	8.55 [0.79]	16/2	—	—	—	—	—	—	.22 [.056]	.25 [.063]	.28 [.071]	.32 [.081]	.36 [.092]	.41 [.103]	—	—
4824	1200/1800 [566/850]	8.55 [0.79]	16/2	—	—	—	—	—	—	.22 [.056]	.25 [.063]	.28 [.071]	.32 [.081]	.32 [.081]	.41 [.103]	—	—
6024	1600/1900 [755/897]	9.98 [0.93]	14/3	—	—	—	—	—	—	—	—	—	—	.27 [.070]	.30 [.076]	.34 [.084]	.37 [.094]

NOTE: Represents Coil-Only Airflow Ratings.

[] Designates Metric Conversion

3.0 INSTALLATION

3.1 APPLICATIONS

(-)CFA-HM and (-)CFL-HM coils can be applied in upflow, downflow, horizontal right and horizontal left applications without modifications. (-)CFA-AU, (-)CFA-HU, (-)CFL-AU and (-)CFL-HU coils can only be applied in upflow and downflow applications (See Table 2 and Figure 3). For horizontal applications, installation of a horizontal drip shield is required. (See Section 5.2: Horizontal Adapter Kit.)

TABLE 2
COIL APPLICATION

Coil Model	Furnace Width (In.) [mm]	
	Oil	Gas
2414, 2417, 3617	—	14 [356]
2417	21 [533]	17½ [444]
3617		14 [356]
3621	21 [533]	21 [533]
4821		17½ [444]
4824	24½ [622]	24½ [622]
6024		21 [533]

NOTE: Due to the proximity of the drain pan to the high temperature oil furnace drum, a horizontal left application is not permitted on all oil furnaces.

CAUTION

For horizontal applications, the horizontal drain pan must be located under the indoor coil. Failure to place the pan under the coil can result in property damage.

For coils that are **two** sizes larger than the furnace, for example, a 21" wide coil on a 14" furnace, a tapered adaptor with a minimum height of 6" is required to evenly distribute airflow. See Figure 4. For coils that are **one** size larger than the furnace; for example a 21" wide coil on a 17½" furnace, seal the gap between the two units with sheet metal, or use the specified adaptor kit (RXBA-AC). See Figure 5.

FIGURE 3
COIL INSTALLATION OPTIONS

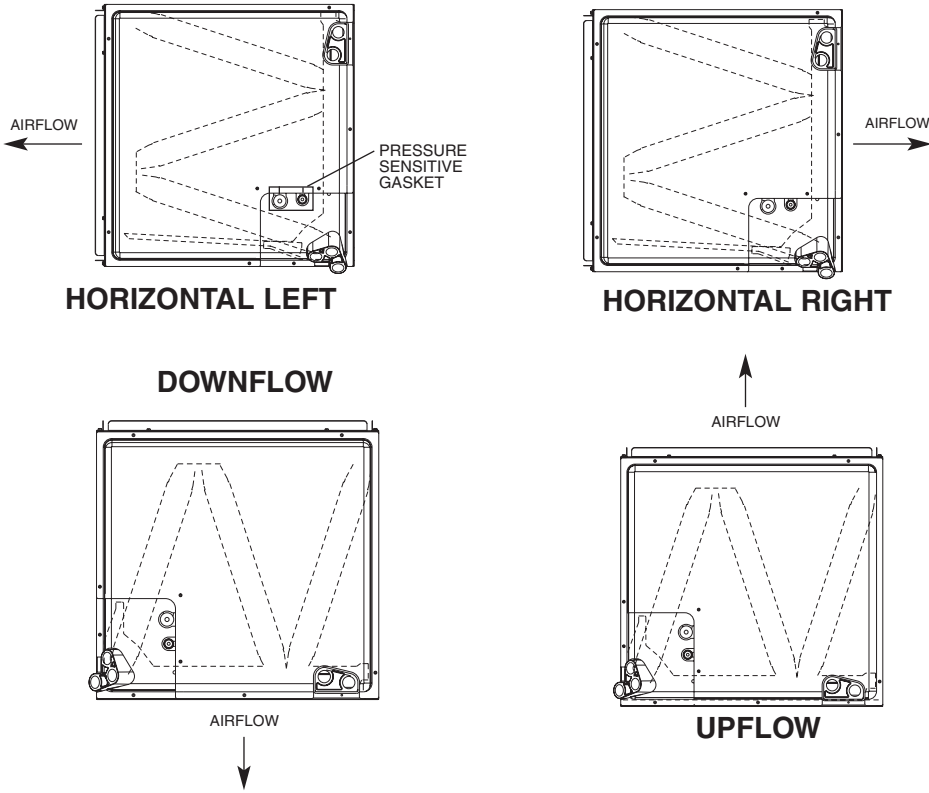

IMPORTANT: Coil must be installed on the supply airflow side of a gas or oil furnace.

FIGURE 4
INSTALLATION OF COIL MATCHED WITH A FURNACE TWO SIZES SMALLER

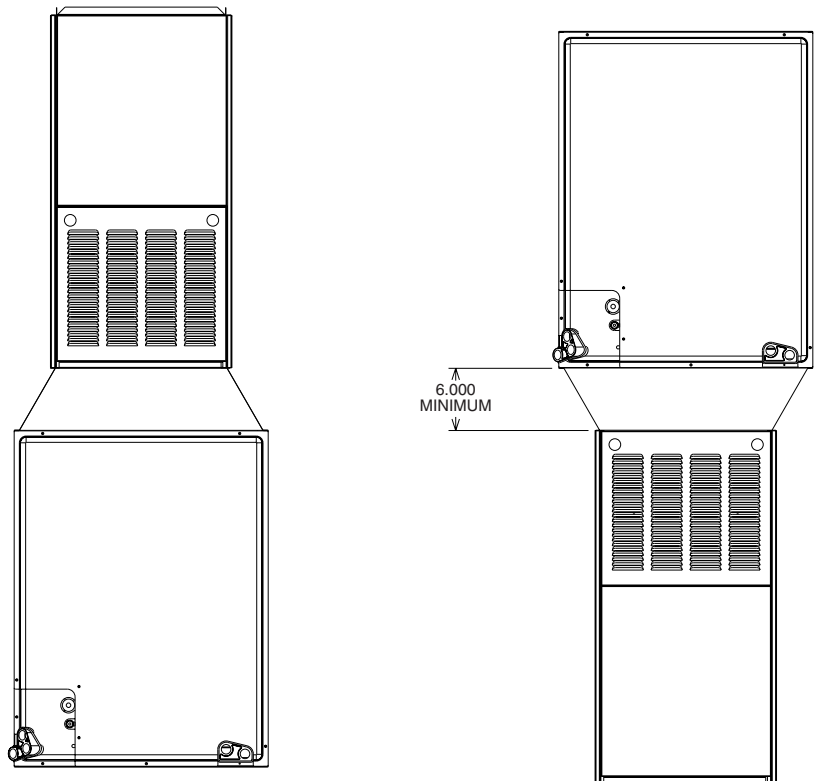
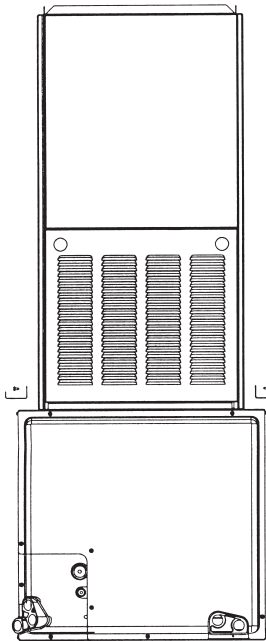
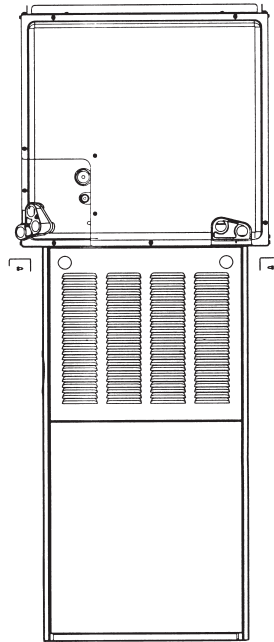

FIGURE 5
INSTALLATION OF COIL MATCHED WITH
A FURNACE OF SMALLER SIZE

**DOWNFLOW OR
HORIZONTAL
RIGHT APPLICATION**



RXBA-AC
PLENUM
ADAPTER



**UPFLOW OR HORIZONTAL
LEFT APPLICATION**

When a cooling coil is matched with a gas furnace of one smaller size, always center coil over the furnace.

IMPORTANT: Seal the gap between the two units with appropriate sheet metal parts, or use the adapter kit RXBA-AC (Upflow/Horizontal).

3.2 REFRIGERANT CONNECTIONS

Keep the coil connections sealed until refrigerant connections are to be made. See the Installation Instructions for the outdoor unit for details on line sizing, tubing installation, and charging information.

Coil is shipped with a low (5 - 10 PSIG) pressure charge of dry nitrogen. Evacuate the system before charging with refrigerant.

Install refrigerant tubing so that it does not block service access to the front of the unit.

Nitrogen should flow through the refrigerant lines while brazing.

Use a brazing shield to protect the cabinet's paint from being damaged by torch flames.

After the refrigerant connections are made, seal the gap around the connections with pressure sensitive gasket. If necessary, cut the gasket into two pieces for a better seal (See Figure 3.)

3.3 TEV SENSING BULB

IMPORTANT: DO NOT perform any soldering with the TEV bulb attached to any line.

After soldering operations have been completed, clamp the TEV bulb securely on the suction line at the 10 to 2 o'clock position with the strap provided in the parts bag.

Insulate the TEV sensing bulb and suction line with the provided pressure sensitive insulation (size 4" x 7") and secure with provided wire ties.

IMPORTANT: TEV sensing bulb should be located on a horizontal section of suction line, just outside of coil box.

3.4 CONDENSATE DRAIN TUBING

Consult local codes or ordinances for specific requirements.

IMPORTANT: When making drain fitting connections to the drain pan, use a thin layer of Teflon paste, silicone or Teflon tape and install hand tight.

IMPORTANT: When making drain fitting connections to drain pan, do not overtighten. Overtightening fittings can split pipe connections on the drain pan.

- Install drain lines so they do not block service access to front of the unit. Minimum clearance of 24 inches is required for filter, coil or blower removal and service access.
- Make sure unit is level or pitched slightly toward primary drain connection so that water will drain completely from the pan. (See Figure 6.)
- Do not reduce drain line size less than connection size provided on condensate drain pan.
- All drain lines must be pitched downward away from the unit a minimum of 1/8" per foot of line to ensure proper drainage.
- Do not connect condensate drain line to a closed or open sewer pipe. Run condensate to an open drain or outdoors.
- The drain line should be insulated where necessary to prevent sweating and damage due to condensate forming on the outside surface of the line.
- Make provisions for disconnecting and cleaning of the primary drain line should it become necessary. Install a 3 in. trap in the primary drain line as close to the unit as possible. Make sure that the top of the trap is below connection to the drain pan to allow complete drainage of pan (See Figure 6).

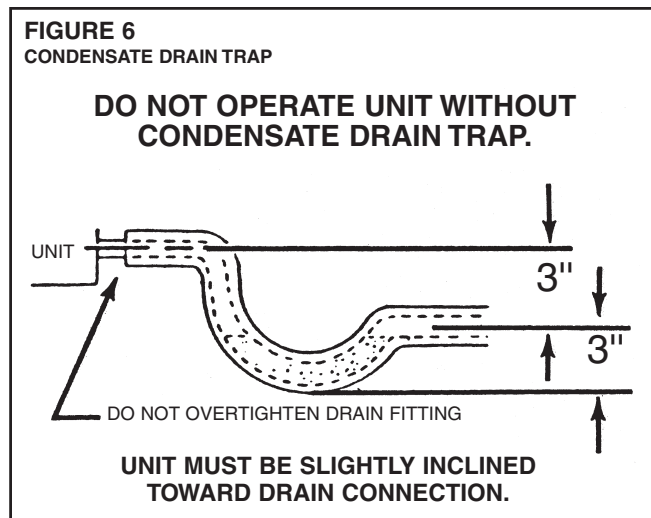

- Auxiliary drain line should be run to a place where it will be noticeable if it becomes operational. Occupant should be warned that a problem exists if water should begin running from the auxiliary drain line.
- Plug the unused drain connection with the plugs provided in the parts bag, using a thin layer of teflon paste, silicone or teflon tape to form a water tight seal.
- Test condensate drain pan and drain line after installation is complete. Pour water into drain pan, enough to fill drain trap and line. Check to make sure drain pan is draining completely, no leaks are found in drain line fittings, and water is draining from the termination of the primary drain line.

3.5 DUCT FLANGES

Field-installed duct flanges (4 pieces) are shipped with units. Install duct flanges as needed on top or bottom of the coil casing. (See Figure 7.)

CAUTION

It is recommended that an auxiliary/secondary drain pan be installed under units containing evaporator coils that are located in any area of a structure where damage to the building or building contents may occur as a result of an overflow of the coil drain pan or a stoppage in the primary condensate drain piping.

4.0 MAINTENANCE

WARNING

These instructions are intended as an aid to qualified licensed service personnel for proper installation, adjustment and operation of this unit. Read these instructions thoroughly before attempting installation or operation. Failure to follow these instructions may result in improper installation, adjustment, service or maintenance possibly resulting in fire, electrical shock, property damage, personal injury or death.

For continuing high performance and to minimize possible equipment failure, it is essential that annual maintenance be performed on this equipment. Consult your local dealer as to the availability of a maintenance contract.

4.1 AIR FILTER

Check the system filter every ninety days or as often as found to be necessary and if obstructed, clean or replace at once.

IMPORTANT: Do not operate the system without a filter in place.

4.2 INDOOR COIL - DRAIN PAN - DRAIN LINE

Inspect the indoor coil once each year for cleanliness and clean as necessary. In some cases, it may be necessary to remove the filter and check the return side of the coil with a mirror and flashlight.

IMPORTANT: Do not use caustic household drain cleaners or bleach in the condensate pan or near the indoor coil. Drain cleaners will quickly damage the indoor coil.

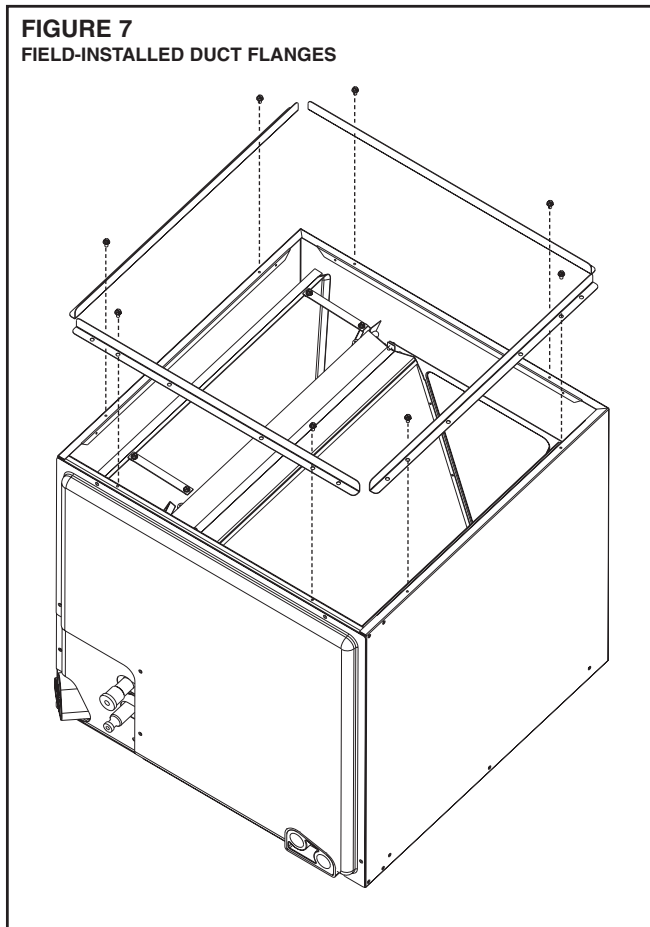

5.0 ACCESSORIES

5.1 PLENUM ADAPTER ACCESSORIES

RXBA-AE

This plenum adapter accessory is for use with the 24-1/2" wide cased indoor cooling and heat pump coils. This allows a 24-1/2 wide cased coil to be installed on a 28" wide oil furnace. This is a field-installed accessory only.

RXBA-AC

This plenum adapter accessory is for installation on cased indoor cooling and heat pump coils. This allows a nominal size cased coil to be installed on the next smaller size gas or oil furnace. **NOTE: This accessory is for installation on coil casings to fit gas or oil furnaces only - this accessory must not be used on electric furnaces or heat pump air handlers.** Consult the installation instructions packaged with the accessory for proper installation.

5.2 HORIZONTAL ADAPTER KIT

RXHH- (See Figure 8)

This horizontal adapter kit is used to convert an upflow or downflow coil for a horizontal application. See Table 3 to order the proper horizontal adapter kit.

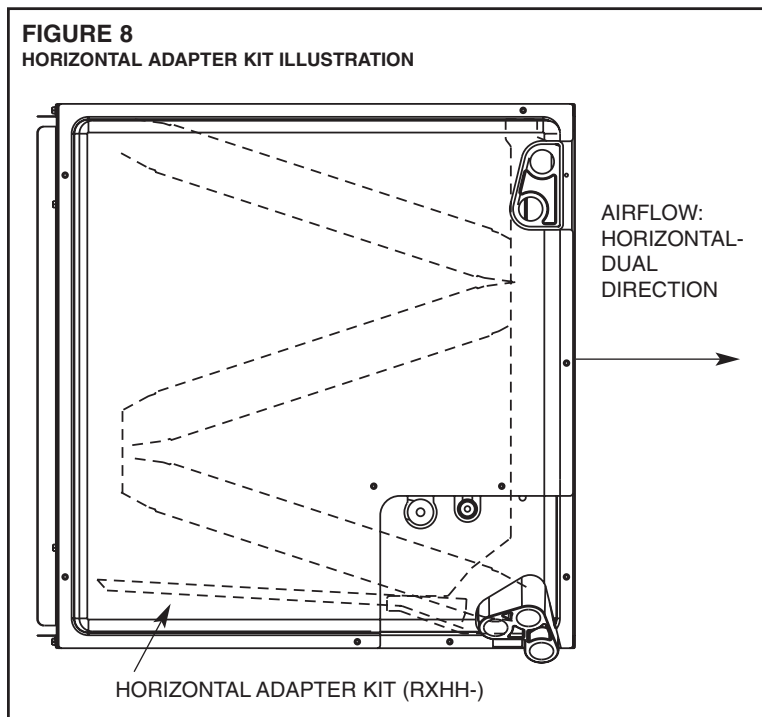

TABLE 3
HORIZONTAL ADAPTER KIT

Coil Model	Horizontal Adapter Kit Model No.
2414	RXHH-A01
2417	RXHH-A02
3617/3621	RXHH-A03
4821/4824	RXHH-A04
6024	RXHH-A05

5.3 INDOOR COIL CASING RXBC - (See Figure 9 & Table 4)

FIGURE 9
MODEL NUMBER EXPLANATION

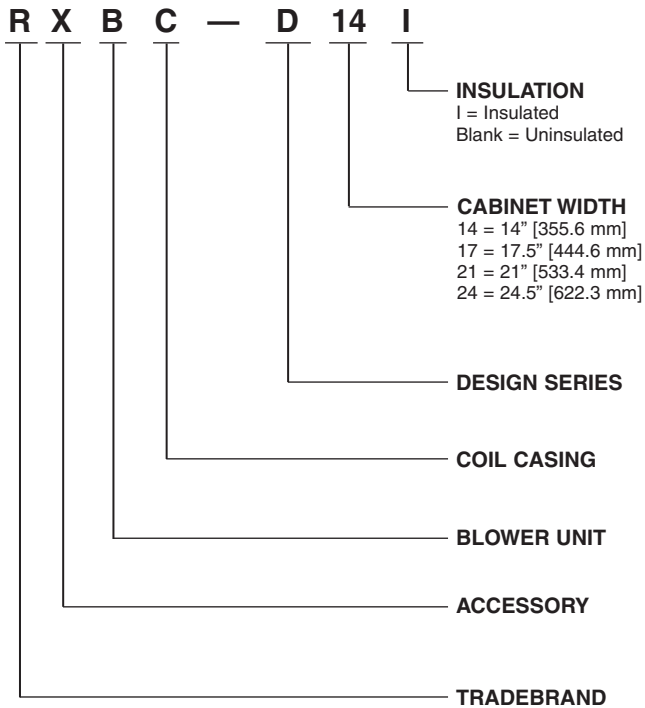

TABLE 4
UNIT DIMENSIONS & WEIGHTS — RXBC- INDOOR COIL CASINGS

Indoor Coil Casing Model Number	Width In.	Height In.	Depth In.	Weight	Shipping Weight	Supply Air/Return Air Openings	
				Lbs [Kg]	Lbs [Kg]	Width In.	Depth In.
RXBC-D14AI	14	23 ³ / ₁₆	21-5/8	19 [9]	23 [10]	13	19 ³¹ / ₃₂
RXBC-D17AI	17½	20		18 [8]	23 [10]	16½	
RXBC-D21AI	21	20		20 [9]	26 [12]	20	
RXBC-D21BI	21	28		27 [12]	36 [17]	20	
RXBC-D24AI	24½	32½		34 [16]	44 [20]	23½	

