



# RQPM

Parts List  
23-February-2021



*This parts list is current as of the above revision date.  
See <http://www.rheempartslists.net/92-42800-RQPM.pdf> for the current revision.*

Package Heat Pumps

# Table of Contents

Model Explanation .....	Page 3
<b>Parts Numbers</b>	
Panels - Miscellaneous (Granite-Steel Gray) 024-043 .....	Page 4
Panels - Miscellaneous (Neutra Green) 024-043 .....	Page 5
Panels - Miscellaneous (Granite-Steel Gray) 048-060 .....	Page 6
Panels - Miscellaneous (Neutra Green) 048-060 .....	Page 7
Electrical Group .....	Page 8
Fan Group .....	Page 9
Blower Group .....	Page 9
Coil Parts .....	Page 10
Compressor Group .....	Page 11
Heater Kits .....	Page 12
Accessories .....	Page 12
<b>Drawings/Photographs</b>	
Exploded View .....	Page 13
Control Panel .....	Page 14
Blower Assembly .....	Page 15
Coil Assembly .....	Page 16
Compressor and Refrigeration Group .....	Page 17
Notes/Disclaimer .....	Page 18

**MODEL NUMBER EXPLANATION**

<b>R</b>	<b>Q</b>	<b>P</b>	<b>M</b>	<b>-</b>	<b>A</b>	<b>0</b>	<b>2</b>	<b>4</b>	<b>J</b>	<b>K</b>	<b>0</b>	<b>0</b>	<b>0</b>
<b>1</b>	<b>2</b>	<b>3</b>	<b>4</b>		<b>5</b>		<b>6</b>		<b>7</b>	<b>8</b>		<b>9</b>	

<b>1</b>	<b>TRADEBRAND</b>	<b>7</b>	<b>ELECTRICAL DESIGNATION</b> J = 208-230/1/60 C = 208-230/3/60
<b>2</b>	<b>PRODUCT CLASSIFICATION</b>		
<b>3</b>	<b>EFFICIENCY DESIGNATION</b> P = 14 SEER	<b>8</b>	<b>DRIVE PACKAGE</b> K = Direct Drive
<b>4</b>	<b>DESIGN SERIES</b> M = R410A	<b>9</b>	<b>HEATING CAPACITY (ELECTRIC HEAT)</b> 000 = No Resistance Heat 005 = 5 kW 007 = 7 kW 010 = 10 kW 015 = 15 kW 020 = 20 kW
<b>5</b>	<b>TECHNICAL VARIATION</b>		
<b>6</b>	<b>COOLING CAPACITY (BTU/HR)</b> 024 = 24,000 030 = 30,000 036/037 = 36,000 042/043 = 42,000 048/049 = 48,000 060 = 60,000		

**SERIAL NUMBER EXPLANATION (Units Produced before Sept. 2013)**

<b>7</b>	<b>1</b>	<b>5</b>	<b>4</b>	<b>F</b>	<b>2</b>	<b>7</b>	<b>0</b>	<b>4</b>	<b>9</b>	<b>9</b>	<b>9</b>	<b>9</b>	<b>9</b>
	<b>1</b>			<b>2</b>	<b>3</b>		<b>4</b>				<b>5</b>		

<b>1</b>	<b>COMPRESSOR IDENTIFICATION NUMBER</b>
<b>2</b>	<b>PRODUCTION LOCATION</b> F = Fort Smith, AR
<b>3</b>	<b>WEEK OF PRODUCTION</b>
<b>4</b>	<b>YEAR OF PRODUCTION</b>
<b>5</b>	<b>PRODUCTION NUMBER</b>

**SERIAL NUMBER EXPLANATION (Units Produced after Sept. 2013)**

<b>W</b>	<b>0</b>	<b>8</b>	<b>1</b>	<b>3</b>	<b>9</b>	<b>9</b>	<b>9</b>	<b>9</b>
(1)	(2)		(3)			(4)		

<b>(1)</b>	<b>PLANT CODE</b> W = Nuevo Laredo (West)
<b>(2)</b>	<b>WEEK OF PRODUCTION</b>
<b>(3)</b>	<b>YEAR OF PRODUCTION</b>
<b>(4)</b>	<b>PRODUCTION NUMBER</b>

**Note: For Compressor Identification Number, see Compressor Code on Rating Plate**

No.	Notes	MODEL TECHNICAL VARIATION COOLING CAPACITY ELECTRICAL DESIGNATION HEATING CAPACITY	RQPM A 024 J 000-010	RQPM A 030 J 000-015	RQPM A 036 C/J 000-015	RQPM A 037 C/J 000-015	RQPM A 042 C/J 000-020	RQPM A 043 C/J 000-020
<b>PANELS, MISCELLANEOUS PARTS (Granite Steel Gray - After F4411)</b>								
1		Panel - Louver	AS-100830-02H	AS-100830-02H	AS-100830-02H	AS-100830-02H	AS-100830-04H	AS-100830-04H
2		Corner Post	AS-100822-01H	AS-100822-01H	AS-100822-01H	AS-100822-01H	AS-100822-02H	AS-100822-02H
3		Front Post	AS-100821-01H	AS-100821-01H	AS-100821-01H	AS-100821-01H	AS-100821-02H	AS-100821-02H
4		Panel - Louver	AS-100830-01H	AS-100830-01H	AS-100830-01H	AS-100830-01H	AS-100830-03H	AS-100830-03H
5		Insulation Retainer	AE-100831-02	AE-100831-02	AE-100831-02	AE-100831-02	AE-100831-03	AE-100831-03
6		Front Access Panel	AS-100823-01H	AS-100823-01H	AS-100823-01H	AS-100823-01H	AS-100823-02H	AS-100823-02H
7		Drainpan	See Coil Group					
8		Air Stop - Drainpan	AE-100825-01	AE-100825-01	AE-100825-01	AE-100825-01	AE-100825-01	AE-100825-01
9		Air Stop - Drainpan	AE-100825-02	AE-100825-02	AE-100825-02	AE-100825-02	AE-100825-02	AE-100825-02
10		Drain Pan Tray	AS-100809-01H	AS-100809-01H	AS-100809-01H	AS-100809-01H	AS-100809-01H	AS-100809-01H
11		Control Access Panel	AS-100824-01H	AS-100824-01H	AS-100824-01H	AS-100824-01H	AS-100824-02H	AS-100824-02H
12		Control Panel Assembly	AS-100807-01	AS-100807-01	AS-100807-01	AS-100807-01	AS-100807-02	AS-100807-02
13		Base Rail (2) - Before F2208	N/A	N/A	N/A	N/A	N/A	N/A
13		Base Rail (2) - After F2208	AE-102792-01	AE-102792-01	AE-102792-01	AE-102792-01	AE-102792-01	AE-102792-01
14		Base Rail (2) - Before F2208	N/A	N/A	N/A	N/A	N/A	N/A
15		Base Pan	AS-100804-01H	AS-100804-01H	AS-100804-01H	AS-100804-01H	AS-100804-01H	AS-100804-01H
16		Right Panel Assembly	AS-100820-01H	AS-100820-01H	AS-100820-01H	AS-100820-01H	AS-100820-02H	AS-100820-02H
17		Blower Support	AE-100818-02	AE-100818-02	AE-100818-02	AE-100818-02	AE-100818-02	AE-100818-02
		Insulation Retainer (2)	AE-100831-01	AE-100831-01	AE-100831-01	AE-100831-01	AE-100831-01	AE-100831-01
		Duct Ring - 14 in.	58-100850-01	58-100850-01	58-100850-01	58-100850-01	58-100850-01	58-100850-01
18		Transition Bottom	AE-100815-01	AE-100815-01	AE-100815-01	AE-100815-01	AE-100815-01	AE-100815-01
19		Transition Top	AE-100815-02	AE-100815-02	AE-100815-02	AE-100815-02	AE-100815-02	AE-100815-02
20		Block Off Plate	AE-100816-01	AE-100816-01	AE-100816-01	AE-100816-01	AE-100816-01	AE-100816-01
21		Rear Panel Assembly	AS-100814-01H	AS-100814-01H	AS-100814-01H	AS-100814-01H	AS-100814-02H	AS-100814-02H
22		Rear Air Stop	AE-100810-01	AE-100810-01	AE-100810-01	AE-100810-01	AE-100810-02	AE-100810-02
23		Top Panel Assembly (Indoor)	AS-100828-01H	AS-100828-01H	AS-100828-01H	AS-100828-01H	AS-100828-01H	AS-100828-01H
24		Top Panel (Outdoor)	AS-100829-01H	AS-100829-01H	AS-100829-01H	AS-100829-01H	AS-100829-01H	AS-100829-01H
25		Grille	95-100906-07	95-100906-07	95-100906-07	95-100906-07	95-100906-07	95-100906-07
28		Blower Support	AE-100818-01	AE-100818-01	AE-100818-01	AE-100818-01	AE-100818-01	AE-100818-01
29		Bulkhead Cap Assembly	AS-100826-01H	AS-100826-01H	AS-100826-01H	AS-100826-01H	AS-100826-01H	AS-100826-01H
30		Bulkhead Assembly	AS-100812-01	AS-100812-01	AS-100812-01	AS-100812-01	AS-100812-02	AS-100812-02
38		Low Voltage Mount	AE-100839-01	AE-100839-01	AE-100839-01	AE-100839-01	AE-100839-01	AE-100839-01
39		Low Voltage Cover	AE-100839-02	AE-100839-02	AE-100839-02	AE-100839-02	AE-100839-02	AE-100839-02
44		Heater Kit Delete Plate (Mounted in Control Box)	AE-100842-01	AE-100842-01	AE-100842-01	AE-100842-01	AE-100842-01	AE-100842-01
51		Gaugeport Enclosure	AE-101352-01	AE-101352-01	AE-101352-01	AE-101352-01	AE-101352-01	AE-101352-01

No.	Notes	MODEL TECHNICAL VARIATION COOLING CAPACITY ELECTRICAL DESIGNATION HEATING CAPACITY	RQPM A 024 J 000-010	RQPM A 030 J 000-015	RQPM A 036 C/J 000-015	RQPM A 037 C/J 000-015	RQPM A 042 C/J 000-020	RQPM A 043 C/J 000-020
<b>PANELS, MISCELLANEOUS PARTS (Neutra Green - Before F4411)</b>								
1		Panel - Louver	AS-100830-02A	AS-100830-02A	AS-100830-02A	AS-100830-02A	AS-100830-04A	AS-100830-04A
2		Corner Post	AS-100822-01A	AS-100822-01A	AS-100822-01A	AS-100822-01A	AS-100822-02A	AS-100822-02A
3		Front Post	AS-100821-01A	AS-100821-01A	AS-100821-01A	AS-100821-01A	AS-100821-02A	AS-100821-02A
4		Panel - Louver	AS-100830-01A	AS-100830-01A	AS-100830-01A	AS-100830-01A	AS-100830-03A	AS-100830-03A
5		Insulation Retainer	AE-100831-02	AE-100831-02	AE-100831-02	AE-100831-02	AE-100831-03	AE-100831-03
6		Front Access Panel	AS-100823-01A	AS-100823-01A	AS-100823-01A	AS-100823-01A	AS-100823-02A	AS-100823-02A
7		Drainpan	See Coil Group					
8		Air Stop - Drainpan	AE-100825-01	AE-100825-01	AE-100825-01	AE-100825-01	AE-100825-01	AE-100825-01
9		Air Stop - Drainpan	AE-100825-02	AE-100825-02	AE-100825-02	AE-100825-02	AE-100825-02	AE-100825-02
10		Drain Pan Tray	AS-100809-01A	AS-100809-01A	AS-100809-01A	AS-100809-01A	AS-100809-01A	AS-100809-01A
11		Control Access Panel	AS-100824-01A	AS-100824-01A	AS-100824-01A	AS-100824-01A	AS-100824-02A	AS-100824-02A
12		Control Panel Assembly	AS-100807-01	AS-100807-01	AS-100807-01	AS-100807-01	AS-100807-02	AS-100807-02
13		Base Rail (2) - Before F2208	AE-100803-01	AE-100803-01	AE-100803-01	AE-102792-01	AE-100803-01	AE-102792-01
13		Base Rail (2) - After F2208	AE-102792-01	AE-102792-01	AE-102792-01	AE-102792-01	AE-102792-01	AE-102792-01
14		Base Rail (2) - Before F2208	AE-100803-02	AE-100803-02	AE-100803-02	N/A	AE-100803-02	N/A
15		Base Pan	AS-100804-01A	AS-100804-01A	AS-100804-01A	AS-100804-01A	AS-100804-01A	AS-100804-01A
16		Right Panel Assembly	AS-100820-01A	AS-100820-01A	AS-100820-01A	AS-100820-01A	AS-100820-02A	AS-100820-02A
17		Blower Support	AE-100818-02	AE-100818-02	AE-100818-02	AE-100818-02	AE-100818-02	AE-100818-02
		Insulation Retainer (2)	AE-100831-01	AE-100831-01	AE-100831-01	AE-100831-01	AE-100831-01	AE-100831-01
		Duct Ring - 14 in.	58-100850-01	58-100850-01	58-100850-01	58-100850-01	58-100850-01	58-100850-01
18		Transition Bottom	AE-100815-01	AE-100815-01	AE-100815-01	AE-100815-01	AE-100815-01	AE-100815-01
19		Transition Top	AE-100815-02	AE-100815-02	AE-100815-02	AE-100815-02	AE-100815-02	AE-100815-02
20		Block Off Plate	AE-100816-01	AE-100816-01	AE-100816-01	AE-100816-01	AE-100816-01	AE-100816-01
21		Rear Panel Assembly	AS-100814-01A	AS-100814-01A	AS-100814-01A	AS-100814-01A	AS-100814-02A	AS-100814-02A
22		Rear Air Stop	AE-100810-01	AE-100810-01	AE-100810-01	AE-100810-01	AE-100810-02	AE-100810-02
23		Top Panel Assembly (Indoor)	AS-100828-01A	AS-100828-01A	AS-100828-01A	AS-100828-01A	AS-100828-01A	AS-100828-01A
24		Top Panel (Outdoor)	AS-100829-01A	AS-100829-01A	AS-100829-01A	AS-100829-01A	AS-100829-01A	AS-100829-01A
25		Grille	95-100833-01	95-100833-01	95-100833-01	95-100906-07	95-100833-01	95-100906-07
28		Blower Support	AE-100818-01	AE-100818-01	AE-100818-01	AE-100818-01	AE-100818-01	AE-100818-01
29		Bulkhead Cap Assembly	AS-100826-01A	AS-100826-01A	AS-100826-01A	AS-100826-01A	AS-100826-01A	AS-100826-01A
30		Bulkhead Assembly	AS-100812-01	AS-100812-01	AS-100812-01	AS-100812-01	AS-100812-02	AS-100812-02
38		Low Voltage Mount	AE-100839-01	AE-100839-01	AE-100839-01	AE-100839-01	AE-100839-01	AE-100839-01
39		Low Voltage Cover	AE-100839-02	AE-100839-02	AE-100839-02	AE-100839-02	AE-100839-02	AE-100839-02
44		Heater Kit Delete Plate (Mounted in Control Box)	AE-100842-01	AE-100842-01	AE-100842-01	AE-100842-01	AE-100842-01	AE-100842-01
51		Gaugeport Enclosure	AE-101352-01	AE-101352-01	AE-101352-01	AE-101352-01	AE-101352-01	AE-101352-01

No.	Notes	MODEL TECHNICAL VARIATION COOLING CAPACITY ELECTRICAL DESIGNATION HEATING CAPACITY	RQPM A 048 C/J 000-020	RQPM A 049 C 000-020	RQPM A 049 J 000-020	RQPM A 060 C 000-020	RQPM A 060 J 000-020
<b>PANELS, MISCELLANEOUS PARTS (Granite Steel Gray - After F4411)</b>							
1		Panel - Louver	AS-100830-04H	AS-100830-04H	AS-100830-04H	AS-100830-04H	AS-100830-04H
2		Corner Post	AS-100822-02H	AS-100822-02H	AS-100822-02H	AS-100822-02H	AS-100822-02H
3		Front Post	AS-100821-02H	AS-100821-02H	AS-100821-02H	AS-100821-02H	AS-100821-02H
4		Panel - Louver	AS-100830-03H	AS-100830-03H	AS-100830-03H	AS-100830-03H	AS-100830-03H
5		Insulation Retainer	AE-100831-03	AE-100831-03	AE-100831-03	AE-100831-03	AE-100831-03
6		Front Access Panel	AS-100823-02H	AS-100823-02H	AS-100823-02H	AS-100823-02H	AS-100823-02H
7		Drainpan	See Coil Group				
8		Air Stop - Drainpan	AE-100825-01	AE-100825-01	AE-100825-01	AE-100825-01	AE-100825-01
9		Air Stop - Drainpan	AE-100825-02	AE-100825-02	AE-100825-02	AE-100825-02	AE-100825-02
10		Drain Pan Tray	AS-100809-01H	AS-100809-01H	AS-100809-01H	AS-100809-01H	AS-100809-01H
11		Control Access Panel	AS-100824-02H	AS-100824-02H	AS-100824-02H	AS-100824-02H	AS-100824-02H
12		Control Panel Assembly	AS-100807-02	AS-100807-02	AS-100807-02	AS-100807-02	AS-100807-02
13		Base Rail (2) - Before F2208	N/A	N/A	N/A	N/A	N/A
13		Base Rail (2) - After F2208	AE-102792-01	AE-102792-01	AE-102792-01	AE-102792-01	AE-102792-01
14		Base Rail (2) - Before F2208	N/A	N/A	N/A	N/A	N/A
15		Base Pan	AS-100804-01H	AS-100804-01H	AS-100804-01H	AS-100804-01H	AS-100804-01H
16		Right Panel Assembly	AS-100820-02H	AS-100820-02H	AS-100820-02H	AS-100820-02H	AS-100820-02H
17		Blower Support	AE-100818-02	AE-100818-02	AE-100818-02	AE-100818-02	AE-100818-02
		Insulation Retainer (2)	AE-100831-01	AE-100831-01	AE-100831-01	AE-100831-01	AE-100831-01
		Duct Ring - 14 in.	58-100850-01	58-100850-01	58-100850-01	58-100850-01	58-100850-01
18		Transition Bottom	AE-100815-01	AE-100815-01	AE-100815-01	AE-100815-01	AE-100815-01
19		Transition Top	AE-100815-02	AE-100815-02	AE-100815-02	AE-100815-02	AE-100815-02
20		Block Off Plate	AE-100816-01	AE-100816-01	AE-100816-01	AE-100816-01	AE-100816-01
21		Rear Panel Assembly	AS-100814-02H	AS-100814-02H	AS-100814-02H	AS-100814-02H	AS-100814-02H
22		Rear Air Stop	AE-100810-02	AE-100810-02	AE-100810-02	AE-100810-02	AE-100810-02
23		Top Panel Assembly (Indoor)	AS-100828-01H	AS-100828-01H	AS-100828-01H	AS-100828-01H	AS-100828-01H
24		Top Panel (Outdoor)	AS-100829-01H	AS-100829-01H	AS-100829-01H	AS-100829-01H	AS-100829-01H
25		Grille	95-100906-07	95-100906-07	95-100906-07	95-100906-07	95-100906-07
28		Blower Support	AE-100818-01	AE-100818-01	AE-100818-01	AE-100818-01	AE-100818-01
29		Bulkhead Cap Assembly	AS-100826-01H	AS-100826-01H	AS-100826-01H	AS-100826-01H	AS-100826-01H
30		Bulkhead Assembly	AS-100812-02	AS-100812-02	AS-100812-02	AS-100812-02	AS-100812-02
38		Low Voltage Mount	AE-100839-01	AE-100839-01	AE-100839-01	AE-100839-01	AE-100839-01
39		Low Voltage Cover	AE-100839-02	AE-100839-02	AE-100839-02	AE-100839-02	AE-100839-02
44		Heater Kit Delete Plate (Mounted in Control Box)	AE-100842-01	AE-100842-01	AE-100842-01	AE-100842-01	AE-100842-01
51		Gaugeport Enclosure	AE-101352-01	AE-101352-01	AE-101352-01	AE-101352-01	AE-101352-01

No.	Notes	MODEL TECHNICAL VARIATION COOLING CAPACITY ELECTRICAL DESIGNATION HEATING CAPACITY	RQPM A 048 C/J 000-020	RQPM A 049 C 000-020	RQPM A 049 J 000-020	RQPM A 060 C 000-020	RQPM A 060 J 000-020
<b>PANELS, MISCELLANEOUS PARTS (Neutra Green - Before F4411)</b>							
1		Panel - Louver	AS-100830-04A	AS-100830-04A	AS-100830-04A	AS-100830-04A	AS-100830-04A
2		Corner Post	AS-100822-02A	AS-100822-02A	AS-100822-02A	AS-100822-02A	AS-100822-02A
3		Front Post	AS-100821-02A	AS-100821-02A	AS-100821-02A	AS-100821-02A	AS-100821-02A
4		Panel - Louver	AS-100830-03A	AS-100830-03A	AS-100830-03A	AS-100830-03A	AS-100830-03A
5		Insulation Retainer	AE-100831-03	AE-100831-03	AE-100831-03	AE-100831-03	AE-100831-03
6		Front Access Panel	AS-100823-02A	AS-100823-02A	AS-100823-02A	AS-100823-02A	AS-100823-02A
7		Drainpan	See Coil Group				
8		Air Stop - Drainpan	AE-100825-01	AE-100825-01	AE-100825-01	AE-100825-01	AE-100825-01
9		Air Stop - Drainpan	AE-100825-02	AE-100825-02	AE-100825-02	AE-100825-02	AE-100825-02
10		Drain Pan Tray	AS-100809-01A	AS-100809-01A	AS-100809-01A	AS-100809-01A	AS-100809-01A
11		Control Access Panel	AS-100824-02A	AS-100824-02A	AS-100824-02A	AS-100824-02A	AS-100824-02A
12		Control Panel Assembly	AS-100807-02	AS-100807-02	AS-100807-02	AS-100807-02	AS-100807-02
13		Base Rail (2) - Before F2208	AE-100803-01	AE-102792-01	AE-102792-01	AE-100803-01	AE-100803-01
13		Base Rail (2) - After F2208	AE-102792-01	AE-102792-01	AE-102792-01	AE-102792-01	AE-102792-01
14		Base Rail (2) - Before F2208	AE-100803-02	N/A	N/A	AE-100803-02	AE-100803-02
15		Base Pan	AS-100804-01A	AS-100804-01A	AS-100804-01A	AS-100804-01A	AS-100804-01A
16		Right Panel Assembly	AS-100820-02A	AS-100820-02A	AS-100820-02A	AS-100820-02	AS-100820-02
17		Blower Support	AE-100818-02	AE-100818-02	AE-100818-02	AE-100818-02	AE-100818-02
		Insulation Retainer (2)	AE-100831-01	AE-100831-01	AE-100831-01	AE-100831-01	AE-100831-01
		Duct Ring - 14 in.	58-100850-01	58-100850-01	58-100850-01	58-100850-01	58-100850-01
18		Transition Bottom	AE-100815-01	AE-100815-01	AE-100815-01	AE-100815-01	AE-100815-01
19		Transition Top	AE-100815-02	AE-100815-02	AE-100815-02	AE-100815-02	AE-100815-02
20		Block Off Plate	AE-100816-01	AE-100816-01	AE-100816-01	AE-100816-01	AE-100816-01
21		Rear Panel Assembly	AS-100814-02A	AS-100814-02A	AS-100814-02A	AS-100814-02	AS-100814-02
22		Rear Air Stop	AE-100810-02	AE-100810-02	AE-100810-02	AE-100810-02	AE-100810-02
23		Top Panel Assembly (Indoor)	AS-100828-01A	AS-100828-01A	AS-100828-01A	AS-100828-01	AS-100828-01
24		Top Panel (Outdoor)	AS-100829-01A	AS-100829-01A	AS-100829-01A	AS-100829-01A	AS-100829-01A
25		Grille	95-100833-01	95-100906-07	95-100906-07	95-100833-01	95-100833-01
28		Blower Support	AE-100818-01	AE-100818-01	AE-100818-01	AE-100818-01	AE-100818-01
29		Bulkhead Cap Assembly	AS-100826-01A	AS-100826-01A	AS-100826-01A	AS-100826-01	AS-100826-01
30		Bulkhead Assembly	AS-100812-02	AS-100812-02	AS-100812-02	AS-100812-02	AS-100812-02
38		Low Voltage Mount	AE-100839-01	AE-100839-01	AE-100839-01	AE-100839-01	AE-100839-01
39		Low Voltage Cover	AE-100839-02	AE-100839-02	AE-100839-02	AE-100839-02	AE-100839-02
44		Heater Kit Delete Plate (Mounted in Control Box)	AE-100842-01	AE-100842-01	AE-100842-01	AE-100842-01	AE-100842-01
51		Gaugeport Enclosure	AE-101352-01	AE-101352-01	AE-101352-01	AE-101352-01	AE-101352-01

No.	Notes	MODEL TECHNICAL VARIATION COOLING CAPACITY ELECTRICAL DESIGNATION HEATING CAPACITY	RQPM A 024 J 000-010	RQPM A 030 J 000-010	RQPM A 036 C 000-015	RQPM A 036 J 000-015	RQPM A 037 C 000-020	RQPM A 037 J 000-020
<b>ELECTRICAL GROUP</b>								
CONTROL BOX COMPONENTS:								
40		Terminal Strip	45-23591-01	45-23591-01	45-23591-01	45-23591-01	45-23591-01	45-23591-01
41	Stk	Transformer	46-18788-11	46-18788-11	46-18788-11	46-18788-11	46-18788-11	46-18788-11
43	Stk	Relay	42-21571-08	42-21571-08	42-21571-08	42-21571-08	42-21571-08	42-21571-08
		Wiring Harness - 6 pin to heater kit	45-104222-01	45-104222-01	45-104222-01	45-104222-01	45-104222-01	45-104222-01
47	Stk	Contact	42-42728-03	42-42728-03	42-22464-01	42-42728-03	42-22464-01	42-42478-04
48	Stk	Capacitor - Compressor/Fan	See Compressor Group					
49		Capacitor Strap (Compressor/Fan)	AE-50892-56	AE-50892-56	AE-50892-01	AE-50892-56	AE-50892-01	AE-50892-56
50	Stk,2	Defrost Control Board - Before F1610 (See Notes 2, 4)	47-21517-18	47-21517-18	47-21517-18	47-21517-18	47-102684-03	47-102684-06
50	Stk,4	Defrost Control Board - After F1610 (See Note 4)	47-102685-04	47-102685-04	47-102685-04	47-102685-04	47-102685-04	47-102685-04
	2	Ambient Sensor - After F1808	47-102709-01	47-102709-01	47-102709-01	47-102709-01	47-102709-01	47-102709-01
	2	Coil Sensor - After F1808	47-102710-02	47-102710-02	47-102710-02	47-102710-02	47-102710-02	47-102710-02
	5	Outdoor Fan Control - See Note 5	N/A	N/A	N/A	N/A	See Fan Group	

No.	Notes	MODEL TECHNICAL VARIATION COOLING CAPACITY ELECTRICAL DESIGNATION HEATING CAPACITY	RQPM A 042 C 000-020	RQPM A 042 J 000-020	RQPM A 043 C 000-020	RQPM A 043 J 000-020	RQPM A 048 C 000-020	RQPM A 048 J 000-020
<b>ELECTRICAL GROUP</b>								
CONTROL BOX COMPONENTS:								
40		Terminal Strip	45-23591-01	45-23591-01	45-23591-01	45-23591-01	45-23591-01	45-23591-01
41	Stk	Transformer	46-18788-11	46-18788-11	46-18788-11	46-18788-11	46-18788-11	46-18788-11
43	Stk	Relay	42-21571-08	42-21571-08	42-21571-08	42-21571-08	42-21571-08	42-21571-08
		Wiring Harness - 6 pin to heater kit	45-104222-01	45-104222-01	45-104222-01	45-104222-01	45-104222-01	45-104222-01
47	Stk	Contact	42-22464-01	42-42728-03	42-22464-01	42-42478-04	42-22464-01	42-42728-03
48	Stk	Capacitor - Compressor/Fan	See Compressor Group					
49		Capacitor Strap (Compressor/Fan)	AE-50892-01	AE-50892-56	AE-50892-01	AE-50892-56	AE-50892-01	AE-50892-56
50	Stk,2	Defrost Control Board - Before F1610 (See Notes 2, 4)	47-21517-18	47-21517-18	47-21517-18	47-21517-18	47-21517-18	47-21517-18
50	Stk,4	Defrost Control Board - After F1610 (See Note 4)	47-102685-04	47-102685-04	47-102685-04	47-102685-04	47-102685-04	47-102685-04
	2	Ambient Sensor - After F1808	47-102709-01	47-102709-01	47-102709-01	47-102709-01	47-102709-01	47-102709-01
	2	Coil Sensor - After F1808	47-102710-02	47-102710-02	47-102710-02	47-102710-02	47-102710-02	47-102710-02

No.	Notes	MODEL TECHNICAL VARIATION COOLING CAPACITY ELECTRICAL DESIGNATION HEATING CAPACITY	RQPM A 049 C 000-020	RQPM A 049 J 000-020	RQPM A 060 C 000-020	RQPM A 060 J 000-020		
<b>ELECTRICAL GROUP</b>								
CONTROL BOX COMPONENTS:								
40		Terminal Strip	45-23591-01	45-23591-01	45-23591-01	45-23591-01		
41	Stk	Transformer	46-18788-11	46-18788-11	46-18788-11	46-18788-11		
		Wiring Harness - 6 pin to heater kit	45-104222-01	45-104222-01	45-104222-01	45-104222-01		
43	Stk	Relay	42-21571-08	42-21571-08	42-21571-08	42-21571-08		
47	Stk	Contact	42-22464-01	42-42478-04	42-22464-01	42-42478-02		
48	Stk	Capacitor - Compressor/Fan	See Compressor Group					
49		Capacitor Strap (Compressor/Fan)	AE-50892-01	AE-50892-56	AE-50892-01	AE-50892-56		
50	Stk,2	Defrost Control Board - Before F1610 (See Notes 2, 4)	47-102684-06	47-102684-06	47-21517-18	47-21517-18		
50	Stk,4	Defrost Control Board - After F1610 (See Note 4)	47-102685-04	47-102685-04	47-102685-04	47-102685-04		
	2	Ambient Sensor - After F1808	47-102709-01	47-102709-01	47-102709-01	47-102709-01		
	2	Coil Sensor - After F1808	47-102710-02	47-102710-02	47-102710-02	47-102710-02		
	5	Outdoor Fan Control - See Note 5	See Fan Group		N/A	N/A		

No.	Notes	MODEL TECHNICAL VARIATION COOLING CAPACITY ELECTRICAL DESIGNATION HEATING CAPACITY	RQPM	RQPM	RQPM	RQPM	RQPM	
			A 024 J 000-010	A 030 J 000-010	A 036 C/J 000-015	A 037 C/J 000-015	A 042 C/J 000-020	
<b>FAN GROUP</b>								
26	Stk	Fan Motor	51-100998-24	51-100998-24	51-100998-24	N/A	51-100998-25	
26	Stk	Fan Motor - Includes Outdoor Fan Control (OFC)	N/A	N/A	N/A	51-103329-02	N/A	
27	Stk	Fan Blade	70-100580-08	70-100580-08	70-100580-08	70-101323-20	70-100580-09	
48		Capacitor - Fan Motor	See Compressor Group					

No.	Notes	MODEL TECHNICAL VARIATION COOLING CAPACITY ELECTRICAL DESIGNATION HEATING CAPACITY	RQPM	RQPM	RQPM	RQPM		
			A 043 C/J 000-020	A 048 C/J 000-020	A 049 C/J 000-020	A 060 C/J 000-020		
<b>FAN GROUP</b>								
26	Stk	Fan Motor	51-100998-25	51-100998-25	N/A	51-100998-25		
26	Stk	Fan Motor - Includes Outdoor Fan Control (OFC)	N/A	N/A	51-103329-01	N/A		
27	Stk	Fan Blade	70-100580-09	70-100580-09	70-100580-09	70-100580-09		
48		Capacitor - Fan Motor	See Compressor Group					

No.	Notes	MODEL TECHNICAL VARIATION COOLING CAPACITY ELECTRICAL DESIGNATION HEATING CAPACITY	RQPM	RQPM	RQPM	RQPM	RQPM
			A 024 J 000-010	A 030 J 000-010	A 036 C/J 000-015	A 037 C/J 000-015	A 042 C/J 000-020
<b>BLOWER GROUP</b>							
	Stk	Blower Assembly	AS-100841-09	AS-100841-10	AS-100841-11	AS-100841-11	AS-100841-12
53	Stk	Blower Housing w/Wheel	70-100840-01	70-100840-01	70-100840-01	70-100840-01	70-100840-02
	Stk	Blower Wheel	703017	703017	703017	703017	703016
54		Motor Band	70-19927-03	70-19927-03	70-19927-03	70-19927-03	70-19927-03
55		Blower Arm Assembly	70-19929-09	70-19929-09	70-19929-09	70-19929-09	70-19929-09
56	Stk	Blower Motor - X13	51-101880-07	51-101880-08	51-101880-09	51-101880-09	51-101920-06

No.	Notes	MODEL TECHNICAL VARIATION COOLING CAPACITY ELECTRICAL DESIGNATION HEATING CAPACITY	RQPM	RQPM	RQPM	RQPM	
			A 043 C/J 000-020	A 048 C/J 000-020	A 049 C/J 000-020	A 060 C/J 000-020	
<b>BLOWER GROUP</b>							
	Stk	Blower Assembly	AS-100841-12	AS-100841-13	AS-100841-13	AS-100841-08	
53	Stk	Blower Housing w/Wheel	70-100840-02	70-100840-02	70-100840-02	70-100840-02	
	Stk	Blower Wheel	703016	703016	703016	703016	
54		Motor Band	70-19927-03	70-19927-03	70-19927-03	70-19927-03	
55		Blower Arm Assembly	70-19929-09	70-19929-09	70-19929-09	70-19929-09	
56	Stk	Blower Motor - X13	51-101920-06	51-101920-07	51-101920-07	51-101984-04	

No.	Notes	MODEL TECHNICAL VARIATION COOLING CAPACITY	RQPM A 024	RQPM A 030	RQPM A 036	RQPM A 037	RQPM A 042
<b>COIL GROUP</b>							
<b>CONDENSER COIL:</b>							
32	Stk	Condenser Coil - Outdoor	AS-100793-14	AS-100793-15	AS-100793-15	AS-100793-15	AS-100793-16
		Distributor Assembly	83-102272-01	83-102272-01	83-102272-01	83-102272-01	83-102272-01
<b>EVAPORATOR COIL:</b>							
33	Stk	Evaporator Coil - Indoor	AS-100792-14	AS-100792-15	AS-100792-15	AS-100792-15	AS-100792-16
33	Stk	Evaporator Coil (Indoor) - Tin Plated	AS-104684-14	AS-104684-15	AS-104684-15	AS-104684-15	AS-104684-16
7	Stk	Drain Pan - Evaporator Coil	68-100808-02	68-100808-02	68-100808-02	68-100808-02	68-100808-02
34		Distributor Assembly	83-102278-01	83-102278-02	83-102278-02	83-102278-02	83-102278-03
35		Drain Trap Assembly	68-100846-02	68-100846-02	68-100846-02	68-100846-02	68-100846-02
37	Stk,3	TXV - Sporlan (See Note 3)	61-102211-07	61-102211-09	61-102211-10	61-102211-11	61-102211-11
37	Stk,3	TXV - Emerson (See Note 3)	N/A	61-102213-05	61-102213-03	61-102213-06	61-102213-06
		TXV Bulb Strap Kit	64-101357-01	64-101357-01	64-101357-01	64-101357-01	64-101357-01
<b>REFRIGERATION GROUP:</b>							
	Stk	Charge Compensator	83-25361-01	N/A	N/A	N/A	N/A
36	Stk,1	Reversing Valve w/Coil - See Note 1	61-102498-09	61-102498-09	61-102498-09	61-102498-09	61-101684-06
	Stk	Solenoid Coil - RV	61-101713-01	61-101713-01	61-101713-01	61-101713-01	61-101713-01
	Stk	Wiring Harness - Reversing Valve	61-26149-01	61-26149-01	61-26149-01	61-26149-01	61-26149-01
52		Gaugeport Manifold - Valve Body (2)	61-22369-04	61-22369-04	61-22369-04	61-22369-04	61-22369-04
52		Gaugeport Manifold - Valve Core (2)	61-18551-01	61-18551-01	61-18551-01	61-18551-01	61-18551-01
		Bulkhead Valve Assembly - After F1610	61-101821-02	61-101821-02	61-101821-02	61-101821-02	61-101821-02
	Stk	Low Pressure Control - After F1610	47-102240-04	47-102240-04	47-102240-04	47-102240-04	47-102240-04
	Stk	Filter Drier	83-41714-03	83-41714-03	83-41714-03	83-41714-03	83-41714-01
		Filter Drier Strap	AE-102132-01	AE-102132-01	AE-102132-01	AE-102132-01	AE-102132-01

No.	Notes	MODEL TECHNICAL VARIATION COOLING CAPACITY	RQPM A 043	RQPM A 048	RQPM A 049	RQPM A 060	
<b>COIL GROUP</b>							
<b>CONDENSER COIL:</b>							
32	Stk	Condenser Coil - Outdoor	AS-103414-01	AS-100793-16	AS-100793-16	AS-100793-17	
		Distributor Assembly	83-102272-02	83-102272-01	83-102272-01	83-102272-02	
<b>EVAPORATOR COIL:</b>							
33	Stk	Evaporator Coil - Indoor	AS-100792-16	AS-100792-16	AS-100792-16	AS-100792-17	
33	Stk	Evaporator Coil (Indoor) - Tin Plated	AS-104684-16	AS-104684-16	AS-104684-16	AS-104684-17	
7	Stk	Drain Pan - Evaporator Coil	68-100808-02	68-100808-02	68-100808-02	68-100808-02	
34		Distributor Assembly	83-102278-03	83-102278-03	83-102278-03	83-102278-04	
35		Drain Trap Assembly	68-100846-02	68-100846-02	68-100846-02	68-100846-02	
37	Stk,3	TXV - Sporlan (See Note 3)	61-102211-11	61-102211-12	61-102211-12	61-102211-13	
37	Stk,3	TXV - Emerson (See Note 3)	N/A	61-102213-07	61-102213-07	61-102213-08	
		TXV Bulb Strap Kit	64-101357-01	64-101357-01	64-101357-01	64-101357-01	
<b>REFRIGERATION GROUP:</b>							
36	Stk,1	Reversing Valve w/Coil - See Note 1	61-101684-06	61-101684-06	61-101684-06	61-101684-03	
	Stk	Solenoid Coil - RV	61-101713-01	61-101713-01	61-101713-01	61-101713-01	
	Stk	Wiring Harness - Reversing Valve	61-26149-01	61-26149-01	61-26149-01	61-26149-01	
52		Gaugeport Manifold - Valve Body (2)	61-22369-04	61-22369-04	61-22369-04	61-22369-04	
52		Gaugeport Manifold - Valve Core (2)	61-18551-01	61-18551-01	61-18551-01	61-18551-01	
		Bulkhead Valve Assembly - After F1610	61-101821-02	61-101821-02	61-101821-02	N/A	
	Stk	Low Pressure Control - After F1610	47-102240-04	47-102240-04	47-102240-04	47-102240-04	
	Stk	High Pressure Control	N/A	N/A	47-102290-01	47-102290-01	
	Stk	Filter Drier	83-41714-01	83-41714-01	83-41714-01	83-41714-01	
		Filter Drier Strap	AE-102132-01	AE-102132-01	AE-102132-01	AE-102132-01	

No.	Notes	MODEL TECHNICAL VARIATION COOLING CAPACITY ELECTRICAL DESIGNATION	RQPM A 024 J	RQPM A 030 J	RQPM A 036 C	RQPM A 036 J	RQPM A 037 C	RQPM A 037 J
<b>COMPRESSOR GROUP</b>								
		<b>Compressor ID:</b>	<b>7560</b>	<b>7561</b>	<b>7569</b>	<b>7562</b>	<b>8092</b>	<b>8088</b>
31	Stk	Compressor	55-102045-24S	55-102045-02S	55-102045-05S	55-102045-03S	55-102045-05S	55-102045-03S
48	Stk	Run Capacitor - Fan/Compressor	43-26261-44	43-26261-09	N/A	43-26261-41	N/A	43-101666-37
48	Stk	Run Capacitor - Fan	N/A	N/A	43-100496-04	N/A	N/A	N/A
57	Stk	Compressor Wiring Harness (Plug)	45-100834-80	45-100834-80	45-100834-80	45-100834-80	45-100834-80	45-100834-80
		Low Pressure Control - After F1610	See Coil Group					

No.	Notes	MODEL TECHNICAL VARIATION COOLING CAPACITY ELECTRICAL DESIGNATION	RQPM A 042 C	RQPM A 042 J	RQPM A 043 C	RQPM A 043 J	RQPM A 048 C	RQPM A 048 J
<b>COMPRESSOR GROUP</b>								
		<b>Compressor ID:</b>	<b>7570</b>	<b>7563</b>	<b>8093</b>	<b>8089</b>	<b>7572</b>	<b>7565</b>
31	Stk	Compressor	55-102045-16S	55-102045-12S	55-102045-16S	55-102045-12S	55-102045-11S	55-102045-09S
48	Stk	Run Capacitor - Fan/Compressor	N/A	43-26261-48	N/A	43-26271-48	N/A	43-26261-47
48	Stk	Run Capacitor - Fan	43-100496-12	N/A	43-100496-12	N/A	43-100496-12	N/A
57	Stk	Compressor Wiring Harness (Plug)	45-100834-80	45-100834-80	45-100834-80	45-100834-80	45-100834-80	45-100834-80
		Low Pressure Control - After F1610	See Coil Group					
		<b>Compressor ID:</b>	<b>7571</b>	<b>7564</b>				
31	Stk	Compressor	55-102282-06S	55-102282-05S				
48	Stk	Run Capacitor - Fan/Compressor	N/A	43-26261-38				
48	Stk	Run Capacitor - Fan	43-100496-12	N/A				
57	Stk	Compressor Wiring Harness (Plug)	45-102303-01	45-102303-01				
		Low Pressure Control - After F1610	See Coil Group					

No.	Notes	MODEL TECHNICAL VARIATION COOLING CAPACITY ELECTRICAL DESIGNATION	RQPM A 049 C	RQPM A 049 J	RQPM A 060 C	RQPM A 060 J		
<b>COMPRESSOR GROUP</b>								
		<b>Compressor ID:</b>	<b>8095</b>	<b>8091</b>	<b>7574</b>	<b>7567</b>		
31	Stk	Compressor	55-102045-11S	55-102045-09S	55-102045-27S	55-102045-26S		
48	Stk	Run Capacitor - Compressor	N/A	43-101666-29	N/A	N/A		
48	Stk	Run Capacitor - Fan	N/A	N/A	43-100496-12	N/A		
48	Stk	Run Capacitor - Fan/Compressor	N/A	N/A	N/A	43-26261-47		
57	Stk	Compressor Wiring Harness (Plug)	45-100834-80	45-100834-80	45-100834-80	45-100834-80		
		Low Pressure Control - After F1610	See Coil Group					
		<b>Compressor ID:</b>			<b>7575</b>	<b>7568</b>		
31	Stk	Compressor			55-102282-02S	55-102282-01		
48	Stk	Run Capacitor - Fan/Compressor			N/A	43-26261-47		
48	Stk	Run Capacitor - Fan			43-100496-12	N/A		
57	Stk	Compressor Wiring Harness (Plug)			45-102303-01	45-102303-01		
		Low Pressure Control - After F1610	See Coil Group					
		<b>Compressor ID:</b>				<b>8581</b>		
31	Stk	Compressor				55-102045-26S		
48	Stk	Run Capacitor - Fan/Compressor				43-101665-47		
48	Stk	Run Capacitor - Fan				N/A		
57	Stk	Compressor Wiring Harness (Plug)				45-100834-80		
		Low Pressure Control - After F1610	See Coil Group					

No.	Notes	MODEL TECHNICAL VARIATION COOLING CAPACITY ELECTRICAL DESIGNATION	RQPM A 024 J	RQPM A 030 J	RQPM A 036/037 C	RQPM A 036/037 J	RQPM A 042 C
<b>HEATER KITS</b>							
		Heater Kit (5 kW)	RXQJ-C05J	RXQJ-C05J	RXQJ-C10C	RXQJ-C05J	RXQJ-C10C
		Heater Kit (7 kW)	RXQJ-C07J	RXQJ-C07J	RXQJ-C15C		RXQJ-C15C
		Heater Kit (10 kW)	RXQJ-C10J	RXQJ-C10J		RXQJ-C10J	RXQJ-C20C
		Heater Kit (15 kW)		RXQJ-C15J		RXQJ-C15J	
		Heater Kit (20 kW) - 036 Only				RXQJ-C20J	

No.	Notes	MODEL TECHNICAL VARIATION COOLING CAPACITY ELECTRICAL DESIGNATION	RQPM A 042 J	RQPM A 043 C	RQPM A 043 J	RQPM A 048/049 C	RQPM A 048/049 J
<b>HEATER KITS</b>							
		Heater Kit (5 kW)	RXQJ-C05J	RXQJ-C10C	RXQJ-C05J	RXQJ-C10C	RXQJ-C05J
		Heater Kit (7 kW)	RXQJ-C07J	RXQJ-C15C	RXQJ-C07J	RXQJ-C15C	RXQJ-C07J
		Heater Kit (10 kW)	RXQJ-C10J	RXQJ-C20C	RXQJ-C10J	RXQJ-C20C	RXQJ-C10J
		Heater Kit (15 kW)		RXQJ-C15J		RXQJ-C15J	RXQJ-C15J
		Heater Kit (20 kW)	RXQJ-C20J		RXQJ-C20J		RXQJ-C20J

No.	Notes	MODEL TECHNICAL VARIATION COOLING CAPACITY ELECTRICAL DESIGNATION	RQPM A 060 C	RQPM A 060 J			
<b>HEATER KITS</b>							
		Heater Kit (5 kW)	RXQJ-C10C	RXQJ-C05J			
		Heater Kit (7 kW)	RXQJ-C15C	RXQJ-C07J			
		Heater Kit (10 kW)	RXQJ-C20C	RXQJ-C10J			
		Heater Kit (15 kW)		RXQJ-C15J			
		Heater Kit (20 kW)		RXQJ-C20J			

No.	Notes	MODEL TECHNICAL VARIATION COOLING CAPACITY	RQPM A ALL				
<b>ACCESSORIES</b>							
		Outdoor Thermostat	RXPT-A01				

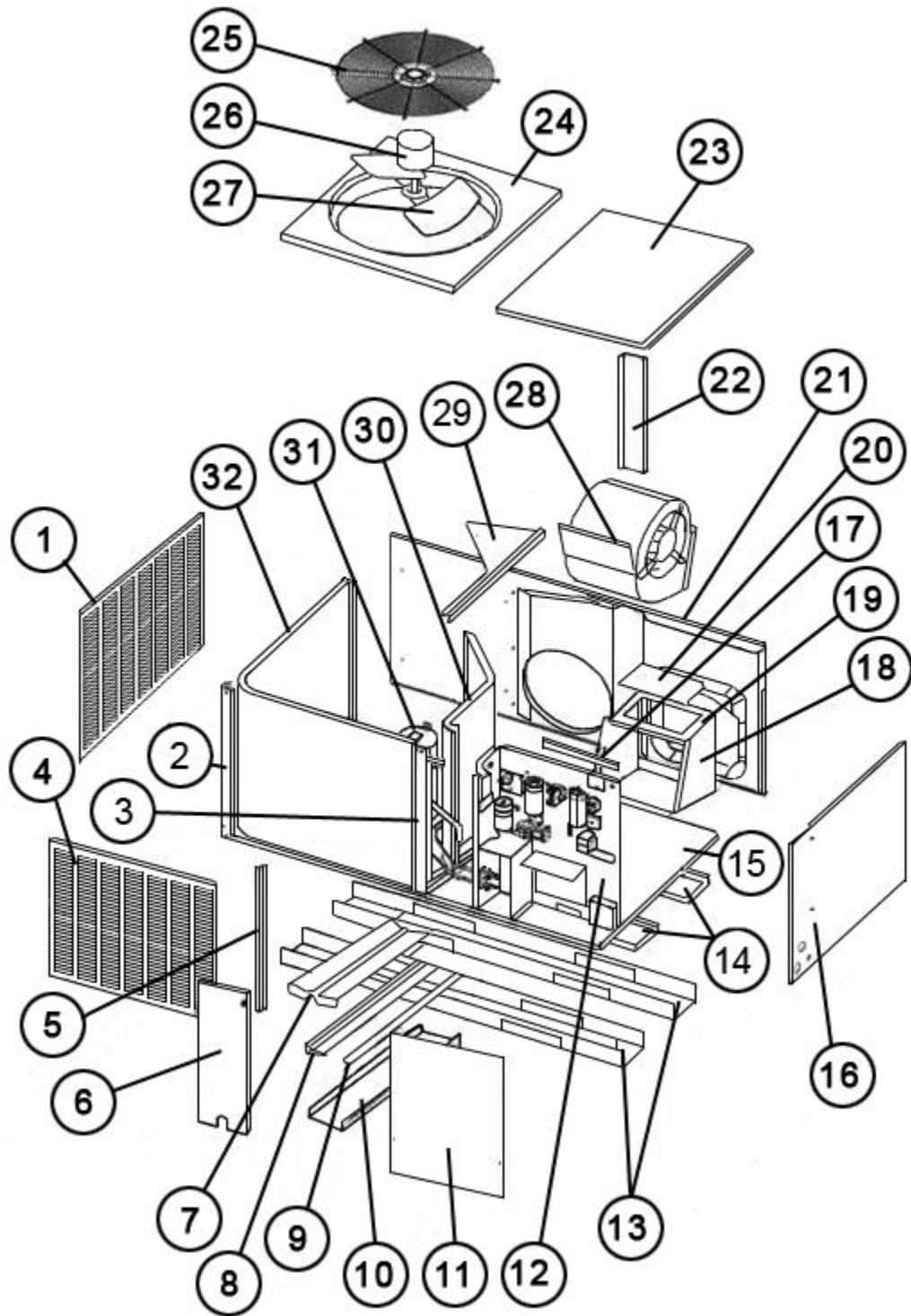

Exploded View

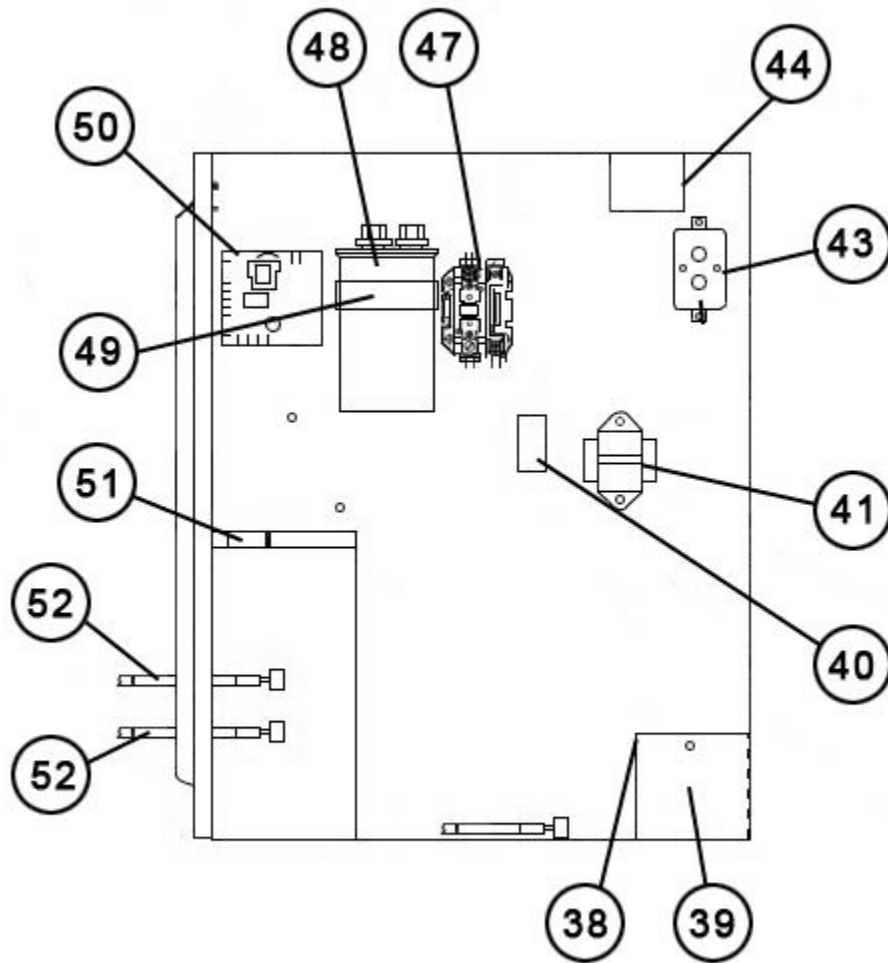

Control Panel

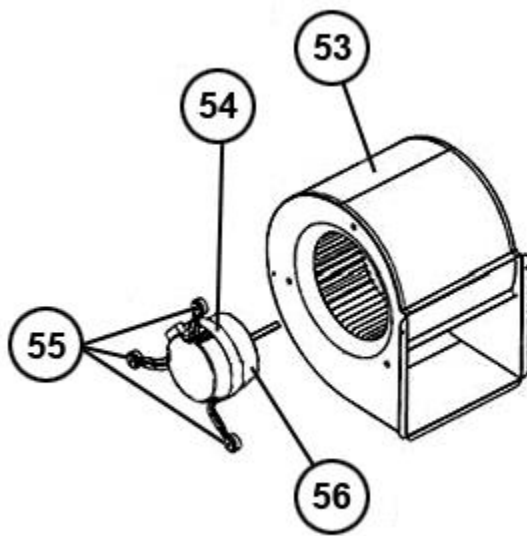

Blower Assembly

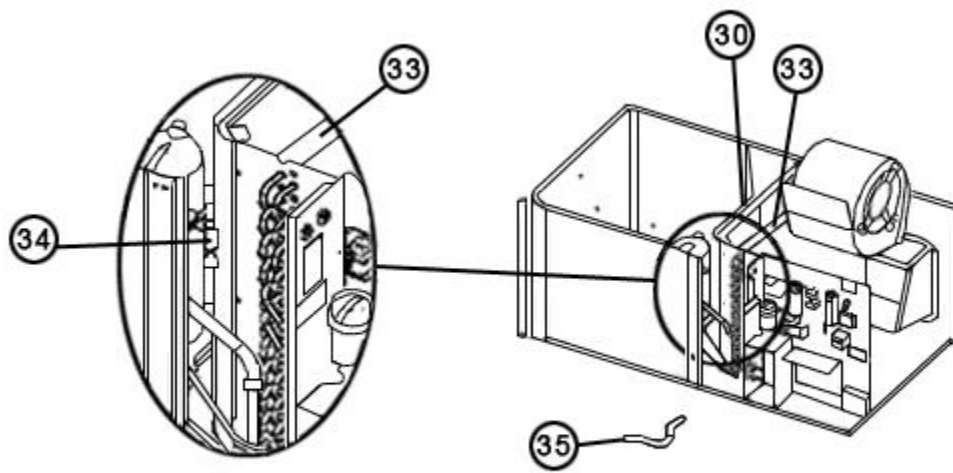

Coil Assembly

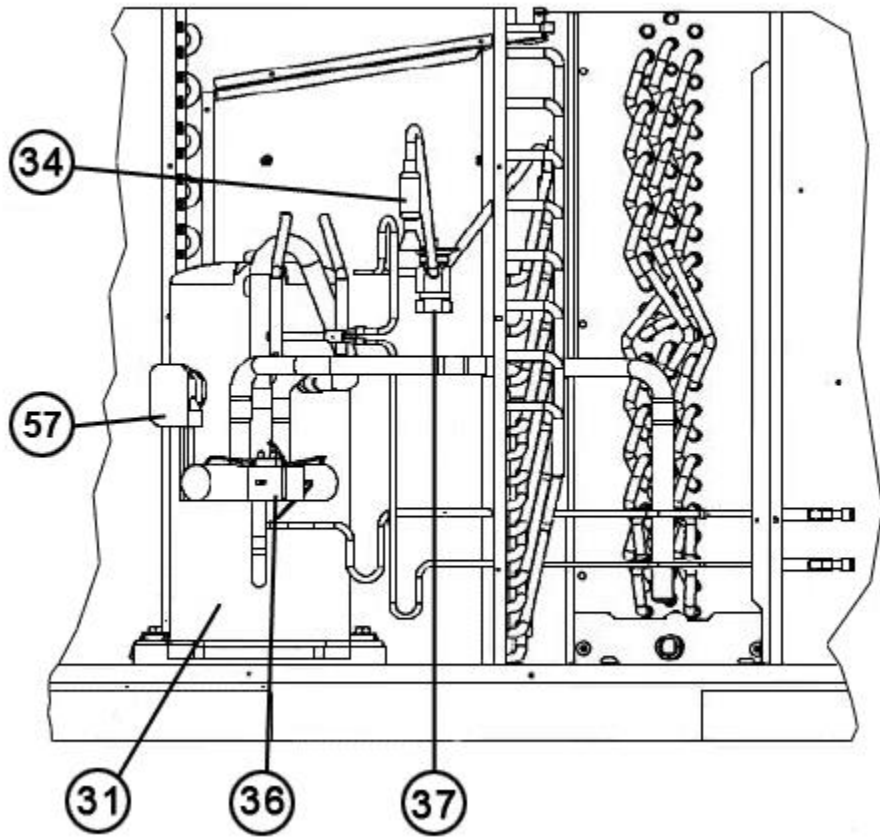

Compressor and Refrigeration Group

# NOTES

Stk It is recommended that stock be maintained for this part.

N/A Not Applicable

- 1 The reversing valve specified for 024, 030, 036, 037, 042, 048 models may be different than the one originally supplied with the equipment. The use of the specified valve is recommended for improved shifting performance.
- 2 The Defrost Control Board before F1808 included integral Ambient and Coil Sensors. Controls used after F1808 have separately replaceable sensors as shown. In all cases, sensors will be included with the replacement board and do not need to be ordered separately when replacing the board.
- 3 The Sporlan and Emerson valves specified for this unit may be interchanged in service. The valves are interchangeable for this specific model only.
- 4 The rectangle-shaped defrost control board used in later production models may be retrofitted in place of the square shaped board used in earlier production. The later defrost board includes support for high and low refrigerant pressure controls and also includes a 30 second compressor delay for noise abatement during defrost. If the unit does not include pressure controls, jumpers will need to be field supplied for these terminals.
- 5 Not available as a separate component.

**DISCLAIMER:** This document is intended to provide general replacement parts information to aid qualified service personnel in the repair of these models. The complete Model and Serial Number of the unit under repair should be specified when selecting and ordering replacement parts. Specifications and illustrations are subject to change without notice. Document 92-42800-RQPM supersedes all previous parts lists for these models. See <http://www.rheempartslists.net/92-42800-RQPM> for the latest revision of this document. The manufacturer assumes no obligation for errors or omissions. Service personnel must verify the proper and safe operation of equipment after the replacement of any original components.