



RP15

Parts List
29-December-2021



*This parts list is current as of the above revision date.
See <http://www.rheempartslists.net/92-42800-RP15.pdf> for the current revision.*

Heat Pumps

Table of Contents

Model Explanation	Page 3
Parts Numbers	
Panels (1)	Page 4
Panels (2)	Page 5
Electrical-Fan Group (1)	Page 6
Electrical-Fan Group (2)	Page 7
Coil Parts (1)	Page 8
Coil Parts (2)	Page 9
Compressor Group (1)	Page 10
Accessories	Page 11
Drawings/Photographs	
Exploded View	Page 12
Control Box (1)	Page 13
Control Box (2)	Page 13
Valve Mounting, Compressor	Page 14
Notes/Disclaimer	Page 15

MODEL NUMBER EXPLANATION

R	P	1	5	1	8	A	J	1	N	A
1	2	3	4	5	6	7	8	9		

- | | |
|---|--|
| <p>(1) Brand</p> <p>(2) Product Category
P = Heat Pump</p> <p>(3) Seer
15 = 15 SEER</p> <p>(4) COOLING CAPACITY (BTU/HR)
018 = 18,000
024 = 24,000
030 = 30,000
036 = 36,000
042 = 42,000
048 = 48,000
060 = 60,000</p> | <p>(5) MAJOR SERIES
A = First Major Design Series
B = Second Major Design Series
C = Third Major Design Series</p> <p>(6) VOLTAGE
J = 208-230/1/60
C = 208-230/3/60
D = 460/3/60</p> <p>(7) TYPE
1 = Single Stage</p> <p>(8) CONTROLS
N = Non-Communicating</p> <p>(9) MINOR SERIES
A = First Design Series</p> |
|---|--|

SERIAL NUMBER EXPLANATION

W	0	8	1	3	9	9	9	9
(1)	(2)	(3)	(4)					

- (1) PLANT CODE**
W = West Nuevo Laredo
- (2) WEEK OF PRODUCTION**
- (3) YEAR OF PRODUCTION**
- (4) PRODUCTION NUMBER**

Note: For Compressor Identification Number, see Compressor Code on Rating Plate

No.	Notes	MODEL COOLING CAPACITY VARIATION	RP15 36 AC1NA	RP15 42 AC1NA	RP15 48 AC1NA	RP15 60 AC1NA	RP15 18 AJ1NA	
SHEET METAL PARTS, MISCELLANEOUS								
1		Front Panel	AE-104456-25	AE-104456-25	AE-104456-43	AE-104456-46	AE-104456-07	
2		Left Panel (Badge Panel)	AE-104456-41	AE-104456-41	AE-104456-56	AE-104456-57	AE-104456-09	
3		Back Panel	AE-104456-26	AE-104456-26	AE-104456-44	AE-104456-47	AE-104456-08	
4		Right Panel	AE-104456-25	AE-104456-25	AE-104456-43	AE-104456-46	AE-104456-10	
5		Base Pan	68-104457-02	68-104457-02	68-104457-03	68-104457-03	68-104457-01	
6		Control Box - Before W1017	AE-104461-01	AE-104461-01	AE-104461-01	AE-104461-01	AE-104461-01	
6		Control Box - On or After W1017	AE-104461-05	AE-104461-05	AE-104461-05	AE-104461-05	AE-104461-05	
7		Control Box Cover	AS-104462-01H	AS-104462-01H	AS-104462-01H	AS-104462-01H	AS-104462-01H	
8		Control Box Bracket	AS-104460-04H	AS-104460-04H	AS-104460-05H	AS-104460-06H	AS-104460-01H	
9		Service Door	AS-104525-01H	AS-104525-01H	AS-104525-01H	AS-104525-01H	AS-104525-01H	
10		Center Post (2)	AS-104459-07H	AS-104459-07H	AS-104459-09H	AS-104459-11H	AS-104459-01H	
		Corner Post - Solid	N/A	N/A	N/A	N/A	AS-104469-08H (1)	
12		Corner Post - Louvered	AS-104469-04H (3)	AS-104469-04H (3)	AS-104469-05H (3)	AS-104469-06H (3)	AS-104469-01H (2)	
13		Top Panel	AS-104458-02H	AS-104458-02H	AS-104458-03H	AS-104458-03H	AS-104458-01H	
14		Venturi	68-104464-06	68-104464-04	68-104464-07	68-104464-05	68-104464-02	
15		Grille	95-104620-05	95-104620-02	95-104620-03	95-104620-03	95-104620-01	
		Center Cap - Blank (for Grille)	91-105471-02	91-101123-00	91-101123-00	91-101123-00	91-101123-00	
		Service Valve - Suction	See Coil Group					
		Service Valve - Liquid	See Coil Group					
		Touch-up Paint - Granite/Steel Gray (Aerosol)	PD523018	PD523018	PD523018	PD523018	PD523018	
		Touch-up Paint - Granite/Steel Gray (Paint Pens)	PD523019	PD523019	PD523019	PD523019	PD523019	

No.	Notes	MODEL COOLING CAPACITY VARIATION	RP15 24 AJ1NA	RP15 30 AJ1NA	RP15 36 AJ1NA	RP15 42 AJ1NA	RP15 48 AJ1NA	RP15 60 AJ1NA
SHEET METAL PARTS, MISCELLANEOUS								
1		Front Panel	AE-104456-07	AE-104456-22	AE-104456-25	AE-104456-25	AE-104456-43	AE-104456-46
2		Left Panel (Badge Panel)	AE-104456-09	AE-104456-24	AE-104456-41	AE-104456-41	AE-104456-56	AE-104456-57
3		Back Panel	AE-104456-08	AE-104456-23	AE-104456-26	AE-104456-26	AE-104456-44	AE-104456-47
4		Right Panel	AE-104456-07	AE-104456-22	AE-104456-25	AE-104456-25	AE-104456-43	AE-104456-46
5		Base Pan	68-104457-01	68-104457-02	68-104457-02	68-104457-02	68-104457-03	68-104457-03
6		Control Box - Before W1017	AE-104461-01	AE-104461-01	AE-104461-01	AE-104461-01	AE-104461-01	AE-104461-01
6		Control Box - On or After W1017	AE-104461-05	AE-104461-05	AE-104461-05	AE-104461-05	AE-104461-05	AE-104461-05
7		Control Box Cover	AS-104462-01H	AS-104462-01H	AS-104462-01H	AS-104462-01H	AS-104462-01H	AS-104462-01H
8		Control Box Bracket	AS-104460-01H	AS-104460-03H	AS-104460-04H	AS-104460-04H	AS-104460-05H	AS-104460-06H
9		Service Door	AS-104525-01H	AS-104525-01H	AS-104525-01H	AS-104525-01H	AS-104525-01H	AS-104525-01H
10		Center Post (2)	AS-104459-01H	AS-104459-05H	AS-104459-07H	AS-104459-07H	AS-104459-09H	AS-104459-11H
12		Corner Post - Louvered	AS-104469-01H (3)	AS-104469-03H (3)	AS-104469-04H (3)	AS-104469-04H (3)	AS-104469-05H (3)	AS-104469-06H (3)
13		Top Panel	AS-104458-01H	AS-104458-02H	AS-104458-02H	AS-104458-02H	AS-104458-03H	AS-104458-03H
14		Venturi	68-104464-02	68-104464-04	68-104464-06	68-104464-04	68-104464-07	68-104464-05
15		Grille	95-104620-01	95-104620-02	95-104620-05	95-104620-02	95-104620-03	95-104620-03
		Center Cap - Blank (for Grille)	91-101123-00	91-101123-00	91-105471-02	91-101123-00	91-101123-00	91-101123-00
		Service Valve - Suction	See Coil Group					
		Service Valve - Liquid	See Coil Group					
		Touch-up Paint - Granite/Steel Gray (Aerosol)	PD523018	PD523018	PD523018	PD523018	PD523018	PD523018
		Touch-up Paint - Granite/Steel Gray (Paint Pens)	PD523019	PD523019	PD523019	PD523019	PD523019	PD523019

No.	Notes	MODEL COOLING CAPACITY VARIATION	RP15 42 BC1NA		RP15 18 BJ1NA	RP15 24 BJ1NA	RP15 30 BJ1NA	RP15 42 BJ1NA
SHEET METAL PARTS, MISCELLANEOUS								
1		Front Panel	AE-104456-43		AE-104456-07	AE-104456-07	AE-104456-22	AE-104456-43
2		Left Panel (Badge Panel)	AE-104456-56		AE-104456-09	AE-104456-09	AE-104456-24	AE-104456-56
3		Back Panel	AE-104456-44		AE-104456-08	AE-104456-08	AE-104456-23	AE-104456-44
4		Right Panel	AE-104456-43		AE-104456-07	AE-104456-07	AE-104456-22	AE-104456-43
5		Base Pan	68-104457-03		68-104457-01	68-104457-01	68-104457-02	68-104457-03
6		Control Box - Before W1017	N/A		AE-104461-01	AE-104461-01	AE-104461-01	N/A
6		Control Box - On or After W1017	AE-104461-05		AE-104461-05	AE-104461-05	AE-104461-05	AE-104461-05
7		Control Box Cover	AS-104462-01H		AS-104462-01H	AS-104462-01H	AS-104462-01H	AS-104462-01H
8		Control Box Bracket	AS-104460-05H		AS-104460-01H	AS-104460-01H	AS-104460-03H	AS-104460-05H
9		Service Door	AS-104525-01H		AS-104525-01H	AS-104525-01H	AS-104525-01H	AS-104525-01H
10		Center Post (2)	AS-104459-09H		AS-104459-01H	AS-104459-01H	AS-104459-05H	AS-104459-09H
12		Corner Post - Solid	N/A		AS-104469-08H (1)	N/A	N/A	N/A
12		Corner Post - Louvered	AS-104469-05H		AS-104469-01H (2)	AS-104469-01H (3)	AS-104469-03H (3)	AS-104469-05H
13		Top Panel	AS-104458-03H		AS-104458-01H	AS-104458-01H	AS-104458-02H	AS-104458-03H
14		Venturi	68-104464-07		68-104464-02	68-104464-02	68-104464-04	68-104464-07
15	1	Grille	95-104620-04		95-104620-01	95-104620-01	95-104620-02	95-104620-04
		Center Cap - Blank (for Grille)	91-105471-02		91-101123-00	91-101123-00	91-101123-00	91-105471-02
		Service Valve - Suction			See Coil Group			
		Service Valve - Liquid			See Coil Group			
		Touch-up Paint - Granite/Steel Gray (Aerosol)	PD523018		PD523018	PD523018	PD523018	PD523018
		Touch-up Paint - Granite/Steel Gray (Paint Pens)	PD523019		PD523019	PD523019	PD523019	PD523019

No.	Notes	MODEL COOLING CAPACITY VARIATION	RP15 18 CJ1NA					
SHEET METAL PARTS, MISCELLANEOUS								
1		Front Panel	AE-104456-07					
2		Left Panel (Badge Panel)	AE-104456-09					
3		Back Panel	AE-104456-08					
4		Right Panel	AE-104456-07					
5		Base Pan	68-104457-01					
6		Control Box - Before W1017	N/A					
6		Control Box - On or After W1017	AE-104461-05					
7		Control Box Cover	AS-104462-01H					
8		Control Box Bracket	AS-104460-01H					
9		Service Door	AS-104525-01H					
10		Center Post (2)	AS-104459-01H					
12		Corner Post - Solid	N/A					
12		Corner Post - Louvered	AS-104469-01H (3)					
13		Top Panel	AS-104458-01H					
14		Venturi	68-104464-02					
15		Grille	95-104620-01					
		Center Cap - Blank (for Grille)	91-101123-00					
		Service Valve - Suction			See Coil Group			
		Service Valve - Liquid			See Coil Group			
		Touch-up Paint - Granite/Steel Gray (Aerosol)	PD523018					
		Touch-up Paint - Granite/Steel Gray (Paint Pens)	PD523019					

No.	Notes	MODEL COOLING CAPACITY VARIATION	RP15 36 AC1NA	RP15 42 AC1NA	RP15 48 AC1NA	RP15 60 AC1NA		RP15 18 AJ1NA
ELECTRICAL/FAN GROUP								
20	Stk	Fan Motor - Before W1017	51-102728-11	51-101774-31	51-102728-13	51-102008-07		51-101774-23
20	Stk	Fan Motor - On or after W1017	51-102728-23	51-101774-31	51-102728-24	51-102008-07		51-101774-23
21	Stk	Fan Blade	70-101323-41	70-101323-34	70-101323-29	70-101323-29		70-101323-26
22	Stk	Contactora	42-102664-14	42-102664-14	42-102664-14	42-102664-14		42-102664-05
23		Capacitor	See Compressor Group					
23a		Capacitor Strap	AE-104562-01	AE-104562-01	AE-104562-01	AE-104562-01		AE-104562-01
24	Stk	Defrost Control Board	47-102685-06	47-102685-06	47-102685-06	47-102685-06		47-102685-06
25		Crankcase Heater	See Compressor Group					
26		Grounding Lug	45-19000-01	45-19000-01	45-19000-01	45-19000-01		45-19000-01
		Low Ambient Control	See Accessories Group					
27	Stk	Low Pressure Control	47-103670-05	47-103670-05	47-103670-05	47-103670-10		47-103670-05
27a		Service Port - Low Pressure Control	61-18542-01	61-18542-01	61-18542-01	61-18542-01		61-18542-01
28	Stk	High Pressure Control	47-103669-01	47-103669-01	47-103669-01	47-103669-01		47-103669-01

No.	Notes	MODEL COOLING CAPACITY VARIATION	RP15 24 AJ1NA	RP15 30 AJ1NA	RP15 36 AJ1NA	RP15 42 AJ1NA	RP15 48 AJ1NA	RP15 60 AJ1NA
ELECTRICAL/FAN GROUP								
20	Stk	Fan Motor - Before W1017	51-102008-17	51-101774-32	51-102728-11	51-101774-32	51-102728-13	51-101774-03
20	Stk	Fan Motor - On or after W1017	51-102008-17	51-101774-32	51-102728-23	51-101774-32	51-102728-24	51-101774-51
21	Stk	Fan Blade	70-101323-33	70-101323-35	70-101323-30	70-101323-34	70-101323-29	70-101323-29
22	Stk	Contactora	42-102664-05	42-102664-05	42-102664-05	42-102664-05	42-102664-10	42-102664-10
23		Capacitor	See Compressor Group					
23a		Capacitor Strap	AE-104562-01	AE-104562-01	AE-104562-01	AE-104562-01	AE-104562-01	AE-104562-01
24	Stk	Defrost Control Board	47-102685-06	47-102685-06	47-102685-06	47-102685-06	47-102685-06	47-102685-06
25		Crankcase Heater	See Compressor Group					
26		Grounding Lug	45-19000-01	45-19000-01	45-19000-01	45-19000-01	45-19000-01	45-19000-01
		Low Ambient Control	See Accessories Group					
27	Stk	Low Pressure Control	47-103670-05	47-103670-05	47-103670-05	47-103670-05	47-103670-05	47-103670-10
27a		Service Port - Low Pressure Control	61-18542-01	61-18542-01	61-18542-01	61-18542-01	61-18542-01	61-18542-01
28	Stk	High Pressure Control	47-103669-01	47-103669-01	47-103669-01	47-103669-01	47-103669-01	47-103669-01

No.	Notes	MODEL COOLING CAPACITY VARIATION	RP15 42 BC1NA		RP15 18 BJ1NA	RP15 24 BJ1NA	RP15 30 BJ1NA	RP15 42 BJ1NA
ELECTRICAL/FAN GROUP								
20	Stk	Fan Motor	51-102728-28		51-102008-18	51-102008-17	51-101774-32	51-102728-28
21	Stk	Fan Blade	70-102345-15		70-101323-26	70-101323-33	70-101323-35	70-102345-15
22	Stk	Contactora	42-104521-14		42-102664-05	42-102664-05	42-102664-05	42-102664-10
23		Capacitor	See Compressor Group					
23a		Capacitor Strap	N/A		AE-104562-01	AE-104562-01	AE-104562-01	AE-104562-01
24	Stk	Defrost Control Board	47-102684-14		47-102685-06	47-102685-06	47-102685-06	47-102684-14
25		Crankcase Heater	See Compressor Group					
26		Grounding Lug	45-19000-01		45-19000-01	45-19000-01	45-19000-01	45-19000-01
		Low Ambient Control	See Accessories Group					
27	Stk	Low Pressure Control	47-103670-05		47-103670-05	47-103670-05	47-103670-05	47-103670-05
27a		Service Port - Low Pressure Control	61-18542-01		61-18542-01	61-18542-01	61-18542-01	61-18542-01
28	Stk	High Pressure Control	47-103669-01		47-103669-01	47-103669-01	47-103669-01	47-103669-01

No.	Notes	MODEL COOLING CAPACITY VARIATION	RP15 18 CJ1NA					
ELECTRICAL/FAN GROUP								
20	Stk	Fan Motor	51-104691-06					
21	Stk	Fan Blade	70-101323-33					
22	Stk	Contactora	42-102664-05					
23		Capacitor	See Compressor Group					
23a		Capacitor Strap	AE-104562-01					
24	Stk	Defrost Control Board	47-102685-07					
25		Crankcase Heater	See Compressor Group					
26		Grounding Lug	45-19000-01					
		Low Ambient Control	See Accessories Group					
27	Stk	Low Pressure Control	47-103670-05					
27a		Service Port - Low Pressure Control	61-18542-01					
28	Stk	High Pressure Control	47-103669-01					

No.	Notes	MODEL COOLING CAPACITY VARIATION	RP15 36 AC1NA	RP15 42 AC1NA	RP15 48 AC1NA	RP15 60 AC1NA	RP15 18 AJ1NA	
COIL GROUP								
30	Stk	Condenser Coil	AS-105093-03	AS-105034-03	AS-105095-03	AS-105214-03	AS-104981-03	
31		Service Valve - Suction	61-104914-03	61-104914-04	61-104914-04	61-104914-04	61-104914-03	
32		Service Valve - Liquid	61-104914-01	61-104914-01	61-104914-01	61-104914-01	61-104914-01	
33		Bulkhead Valve	61-22369-04	61-22369-04	61-22369-04	61-22369-04	61-22369-04	
33a		Valve Core	61-18551-01	61-18551-01	61-18551-01	61-18551-01	61-18551-01	
33b		Valve Cap	83-100635-01	83-100635-01	83-100635-01	83-100635-01	83-100635-01	
		Locknut - Bulkhead Valve	63-22368-01	63-22368-01	63-22368-01	63-22368-01	63-22368-01	
27	Stk	Low Pressure Control	See Electrical Group					
28	Stk	High Pressure Control	See Electrical Group					
	Stk	Filter Drier	83-41719-04	83-41719-04	83-41719-04	83-41719-04	83-41719-04	
		Charge Compensator	N/A	N/A	83-104499-11	83-104499-11	83-104499-01	
29a	Stk	TXV/Distributor Assembly (Before Date Listed)	61-105025-10 (W4021)	61-105025-06	61-105025-12	61-105025-13 (W3821)	61-105025-01	
		TXV/Distributor Assembly (On or After Date Listed)	61-107128-09 (W4021)	61-105025-06	61-105025-12	61-107128-13 (W3821)	61-105025-01	
29b	Stk	Reversing Valve (Before Date Listed)	61-102498-09	61-102498-09	RXTB-A06 (W3018)	RXTB-A05 (W4216)	61-102498-04	
	Stk	Reversing Valve (On or After Date Listed)	61-102498-09	61-102498-09	61-102498-06 (W3018)	61-102498-06 (W4216)	61-102498-04	
	Stk	Solenoid Coil - Reversing Valve	61-101713-92	61-101713-92	61-101713-92	61-101713-92	61-101713-92	
		Wiring Harness - Reversing Valve (Before Date Listed)	61-26149-03 (W0917)	61-26149-03 (W0917)	61-26149-03 (W0917)	61-26149-03 (W0917)	61-26149-03 (W0917)	
		Wiring Harness - Reversing Valve (On or After Date Listed)	61-26149-05 (W0917)	61-26149-05 (W0917)	61-26149-05 (W0917)	61-26149-05 (W0917)	61-26149-05 (W0917)	

No.	Notes	MODEL COOLING CAPACITY VARIATION	RP15 24 AJ1NA	RP15 30 AJ1NA	RP15 36 AJ1NA	RP15 42 AJ1NA	RP15 48 AJ1NA	RP15 60 AJ1NA	
COIL GROUP									
30	Stk	Condenser Coil	AS-105088-03	AS-105090-03	AS-105093-03	AS-105034-03	AS-105095-03	AS-105214-03	
31		Service Valve - Suction	61-104914-03	61-104914-03	61-104914-03	61-104914-04	61-104914-04	61-104914-04	
32		Service Valve - Liquid	61-104914-01	61-104914-01	61-104914-01	61-104914-01	61-104914-01	61-104914-01	
33		Bulkhead Valve	61-22369-04	61-22369-04	61-22369-04	61-22369-04	61-22369-04	61-22369-04	
33a		Valve Core	61-18551-01	61-18551-01	61-18551-01	61-18551-01	61-18551-01	61-18551-01	
33b		Valve Cap	83-100635-01	83-100635-01	83-100635-01	83-100635-01	83-100635-01	83-100635-01	
		Locknut - Bulkhead Valve	63-22368-01	63-22368-01	63-22368-01	63-22368-01	63-22368-01	63-22368-01	
27	Stk	Low Pressure Control	See Electrical Group						
28	Stk	High Pressure Control	See Electrical Group						
	Stk	Filter Drier	83-41719-04	83-41719-04	83-41719-04	83-41719-04	83-41719-04	83-41719-04	
		Charge Compensator	N/A	N/A	N/A	N/A	83-104499-11	83-104499-11	
29a	Stk	TXV/Distributor Assembly (Before Date Listed)	61-105025-08	61-105025-09 (W4221)	61-105025-10 (W3519)	61-105025-06	61-105025-12	61-105025-13 (W1621)	
	Stk	TXV/Distributor Assembly (On or After Date Listed)	61-105025-08	61-107128-09 (W4221)	61-107128-10 (W3619)	61-105025-06	61-105025-12	61-108248-13 (W1621)	
29b	Stk	Reversing Valve (Before Date Listed)	61-102498-04	61-102498-09	61-102498-09	61-102498-09	RXTB-A06 (W3018)	RXTB-A05 (W4216)	
	Stk	Reversing Valve (On or After Date Listed)	61-102498-04	61-102498-09	61-102498-09	61-102498-09	61-102498-06 (W3018)	61-102498-06 (W4216)	
	Stk	Solenoid Coil - Reversing Valve	61-101713-92	61-101713-92	61-101713-92	61-101713-92	61-101713-92	61-101713-92	
		Wiring Harness - Reversing Valve (Before Date Listed)	61-26149-03 (W0917)	61-26149-03 (W0917)	61-26149-03 (W0917)	61-26149-03 (W0917)	61-26149-03 (W0917)	61-26149-03 (W0917)	
		Wiring Harness - Reversing Valve (On or After Date Listed)	61-26149-05 (W0917)	61-26149-05 (W0917)	61-26149-05 (W0917)	61-26149-05 (W0917)	61-26149-05 (W0917)	61-26149-05 (W0917)	

No.	Notes	MODEL COOLING CAPACITY VARIATION	RP15 42 BC1NA		RP15 18 BJ1NA	RP15 24 BJ1NA	RP15 30 BJ1NA	RP15 42 BJ1NA
COIL GROUP								
30	Stk	Condenser Coil	AS-105095-03		AS-104981-03	AS-105088-03	AS-105090-03	AS-105095-03
31		Service Valve - Suction	61-104914-04		61-104914-03	61-104914-03	61-104914-03	61-104914-04
32		Service Valve - Liquid	61-104914-05		61-104914-01	61-104914-01	61-104914-01	61-104914-05
33		Bulkhead Valve	61-22369-04		61-22369-04	61-22369-04	61-22369-04	61-22369-04
33a		Valve Core	61-18551-01		61-18551-01	61-18551-01	61-18551-01	61-18551-01
33b		Valve Cap	83-100635-01		83-100635-01	83-100635-01	83-100635-01	83-100635-01
		Locknut - Bulkhead Valve	63-22368-01		63-22368-01	63-22368-01	63-22368-01	63-22368-01
27	Stk	Low Pressure Control	See Electrical Group					
28	Stk	High Pressure Control	See Electrical Group					
	Stk	Filter Drier	83-104825-01		83-41719-04	83-41719-04	83-41719-04	83-104825-01
		Charge Compensator	N/A		83-104499-02	83-104499-01	N/A	N/A
29a	Stk	TXV/Distributor Assembly (Before Date Listed)	61-107128-06		61-105025-01	61-105025-08	61-105025-09 (W3519)	61-107128-06
	Stk	TXV/Distributor Assembly (On or After Date Listed)	61-107128-06		61-105025-01	61-105025-08	61-107128-09 (W3519)	61-107128-06
29b	Stk	Reversing Valve (Before Date Listed)	61-102498-09		RXTB-A11 (W0521)	61-102498-04	61-102498-09	61-102498-09
		Reversing Valve (On or After Date Listed)	61-102498-09		61-102498-04 (W0521)	61-102498-04	61-102498-09	61-102498-09
	Stk	Solenoid Coil - Reversing Valve	61-101713-92		61-101713-92	61-101713-92	61-101713-92	61-101713-92
		Wiring Harness - Reversing Valve (Before Date Listed)	N/A		61-26149-03 (W0917)	61-26149-03 (W0917)	61-26149-03 (W0917)	N/A
		Wiring Harness - Reversing Valve (On or After Date Listed)	61-26149-05		61-26149-05 (W0917)	61-26149-05 (W0917)	61-26149-05 (W0917)	61-26149-05

No.	Notes	MODEL COOLING CAPACITY VARIATION	RP15 18 CJ1NA					
COIL GROUP								
30	Stk	Condenser Coil	AS-105088-03					
31		Service Valve - Suction	61-104914-03					
32		Service Valve - Liquid	61-104914-05					
33		Bulkhead Valve	61-22369-04					
33a		Valve Core	61-18551-01					
33b		Valve Cap	83-100635-01					
		Locknut - Bulkhead Valve	63-22368-01					
27	Stk	Low Pressure Control	See Electrical Group					
28	Stk	High Pressure Control	See Electrical Group					
	Stk	Filter Drier	83-104825-01					
		Charge Compensator	83-104499-01					
29a	Stk	TXV/Distributor Assembly	61-105025-08					
29b	Stk	Reversing Valve	61-102498-04					
	Stk	Solenoid Coil - Reversing Valve	61-101713-92					
		Wiring Harness - Reversing Valve	61-26149-05					

No.	Notes	MODEL COOLING CAPACITY VARIATION	RP15 36 AC1NA	RP15 42 AC1NA	RP15 48 AC1NA	RP15 60 AC1NA	RP15 18 AJ1NA	
COMPRESSOR GROUP								
		Compressor ID:	9038	9039	9040	9041	9012	
40	Stk	Compressor	55-102045-138S	55-102045-133S	55-102045-139S	55-102045-130S	55-102045-120	
		Compressor Grommet (4)	56-18518-04	56-18518-06	56-18518-06	56-18518-06	56-18518-04	
		Compressor Bolt (4)	63-20072-07	63-20072-07	63-20072-07	63-20072-07	63-20072-07	
23	Stk	Capacitor - Compressor/Fan	N/A	N/A	N/A	N/A	43-101665-60	
23	Stk	Capacitor - Fan	N/A	43-101666-65	43-101666-68	43-101666-62	N/A	
23	Stk	Capacitor - Compressor	N/A	N/A	N/A	N/A	N/A	
	Stk	Compressor Wiring Harness (Molded Plug)	45-100834-80	45-100834-80	45-100834-80	45-100834-80	45-100834-80	
25		Crankcase Heater	See Accessories		44-103663-13	44-103663-13	See Accessories	
		Muffler	83-104416-01	83-104416-01	83-104416-01	83-104416-01	83-104416-01	
		Filter Drier	83-41719-04	83-41719-04	83-41719-04	83-41719-04	83-41719-04	
		Charge Compensator	See Coil Group					

No.	Notes	MODEL COOLING CAPACITY VARIATION	RP15 24 AJ1NA	RP15 30 AJ1NA	RP15 36 AJ1NA	RP15 42 AJ1NA	RP15 48 AJ1NA	RP15 60 AJ1NA	
COMPRESSOR GROUP									
		Compressor ID:	9013	9014	9015	9016	9017	9018	
40	Stk	Compressor	55-102045-121	55-102045-123	55-102045-103S	55-102045-126	55-102045-119S	55-102045-101S	
		Compressor Grommet (4)	56-18518-04	56-18518-04	56-18518-04	56-18518-06	56-18518-06	56-18518-06	
		Compressor Bolt (4)	63-20072-07	63-20072-07	63-20072-07	63-20072-07	63-20072-07	63-20072-07	
23	Stk	Capacitor - Compressor/Fan	43-101665-10	43-101665-61	43-101666-68	43-101665-62	43-101666-68	43-101665-58	
	Stk	Compressor Wiring Harness (Molded Plug)	45-100834-80	45-100834-80	45-100834-80	45-100834-80	45-100834-80	45-100834-80	
25		Crankcase Heater	See Accessories				44-103663-13	44-103663-13	
		Muffler	83-104416-01	83-104416-01	83-104416-01	83-104416-01	83-104416-01	83-104416-01	
		Filter Drier	83-41719-04	83-41719-04	83-41719-04	83-41719-04	83-41719-04	83-41719-04	
		Charge Compensator	See Coil Group						

No.	Notes	MODEL COOLING CAPACITY VARIATION	RP15 42 BC1NA		RP15 18 BJ1NA	RP15 24 BJ1NA	RP15 30 BJ1NA	RP15 42 BJ1NA
COMPRESSOR GROUP								
		Compressor ID:	9564		9092	9089	9093	9563
40	Stk	Compressor	55-102045-145S		55-102045-122S	55-102045-148	55-102045-143S	55-102045-144S
		Compressor Grommet (4)	56-18518-06		56-18518-04	56-18518-04	56-18518-04	56-18518-06
		Compressor Bolt (4)	63-20072-07		63-20072-07	63-20072-07	63-20072-07	63-20072-07
23	Stk	Capacitor - Compressor/Fan	N/A		43-101665-60	43-101665-60	43-101665-61	43-101666-68
	Stk	Compressor Wiring Harness (Molded Plug)	45-100834-80		45-100834-80	45-100834-80	45-100834-80	45-100834-80
25		Crankcase Heater	44-103663-13		See Accessories			44-103663-13
		Muffler	83-104416-01		83-104416-01	83-104416-01	83-104416-01	83-104416-01
		Filter Drier	83-104825-01		83-41719-04	83-41719-04	83-41719-04	83-104825-01
		Charge Compensator	See Coil Group					

No.	Notes	MODEL COOLING CAPACITY VARIATION	RP15 18 CJ1NA						
COMPRESSOR GROUP									
		Compressor ID:	9556						
40	Stk	Compressor	55-102045-122S						
		Compressor Grommet (4)	56-18518-04						
		Compressor Bolt (4)	63-20072-07						
23	Stk	Capacitor - Compressor/Fan	43-101665-06						
	Stk	Compressor Wiring Harness (Molded Plug)	45-100834-80						
25		Crankcase Heater	See Accessories						
		Muffler	83-104416-01						
		Filter Drier	83-104825-01						
		Charge Compensator	See Coil Group						

No.	Notes	MODEL COOLING CAPACITY VARIATION	RP15 36 AC1NA	RP15 42 AC1NA	RP15 48 AC1NA	RP15 60 AC1NA		RP15 18 AJ1NA
ACCESSORIES								
		Low Ambient Control	RXAD-A08	RXAD-A08	RXAD-A08	RXAD-A08		RXAD-A08
		Compressor Crankcase Heater	44-17402-44	44-17402-45	See Compressor Group			44-17402-44
		Compressor Sound Cover	68-23427-26	68-23427-25	68-23427-25	68-23427-25		68-23427-26
		Compressor Hard Start Kit	SK-A1	SK-A1	SK-A1	SK-A1		SK-A1

No.	Notes	MODEL COOLING CAPACITY VARIATION	RP15 24 AJ1NA	RP15 30 AJ1NA	RP15 36 AJ1NA	RP15 42 AJ1NA	RP15 48 AJ1NA	RP15 60 AJ1NA
ACCESSORIES								
		Low Ambient Control	RXAD-A08	RXAD-A08	RXAD-A08	RXAD-A08	RXAD-A08	RXAD-A08
		Compressor Crankcase Heater	44-17402-44	44-17402-44	44-17402-44	44-17402-45	See Compressor Group	
		Compressor Sound Cover	68-23427-26	68-23427-26	68-23427-26	68-23427-25	68-23427-25	68-23427-25
		Compressor Hard Start Kit	SK-A1	SK-A1	SK-A1	SK-A1	SK-A1	SK-A1

No.	Notes	MODEL COOLING CAPACITY VARIATION	RP15 42 BC1NA		RP15 18 BJ1NA	RP15 24 BJ1NA	RP15 30 BJ1NA	RP15 42 BJ1NA
ACCESSORIES								
		Low Ambient Control	RXAD-A08		RXAD-A08	RXAD-A08	RXAD-A08	RXAD-A08
		Compressor Crankcase Heater	See Compressor		44-17402-44	44-17402-44	44-17402-44	See Compressor
		Compressor Sound Cover	68-23427-25		68-23427-26	68-23427-26	68-23427-26	68-23427-25
		Compressor Hard Start Kit	SK-A1		SK-A1	SK-A1	SK-A1	SK-A1

No.	Notes	MODEL COOLING CAPACITY VARIATION	RP15 18 CJ1NA					
ACCESSORIES								
		Low Ambient Control	RXAD-A08					
		Compressor Crankcase Heater	44-17402-44					
		Compressor Sound Cover	68-23427-26					
		Compressor Hard Start Kit	SK-A1					

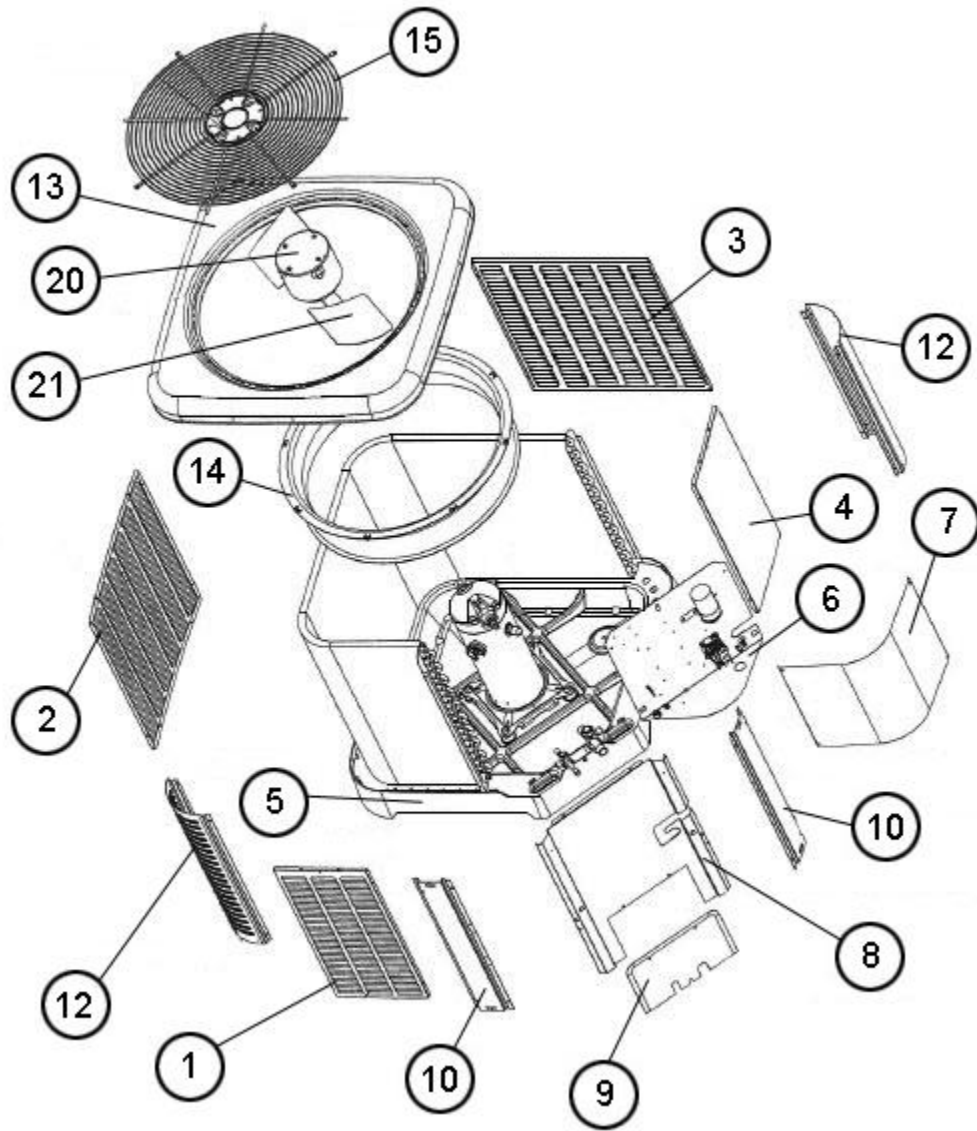

Exploded View

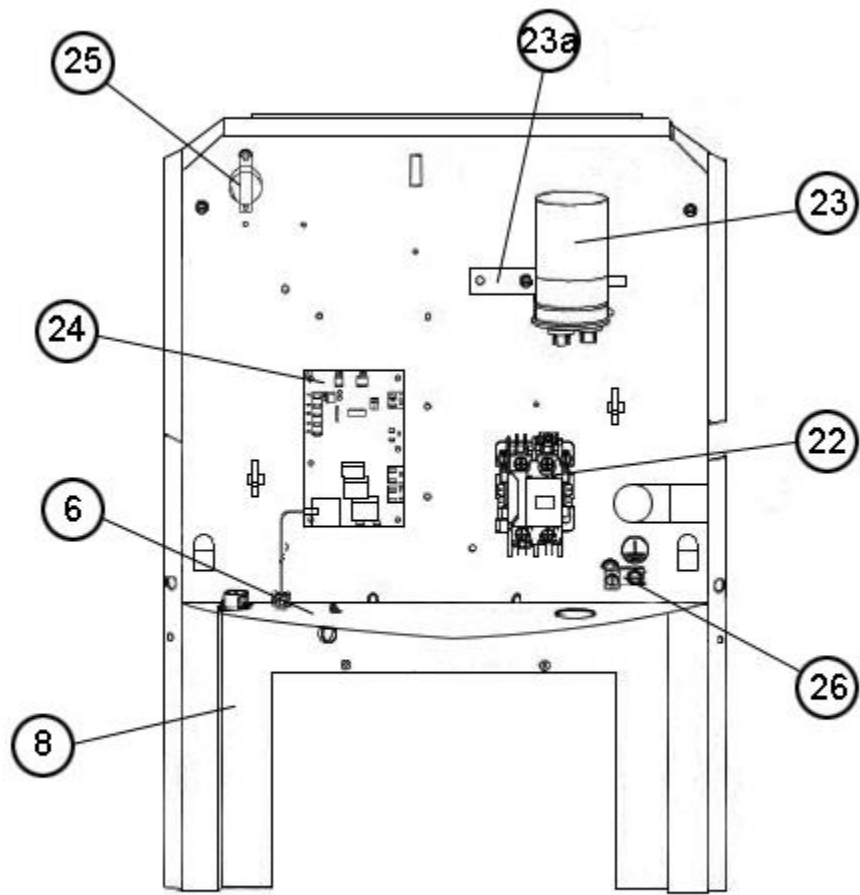

Control Box (1)

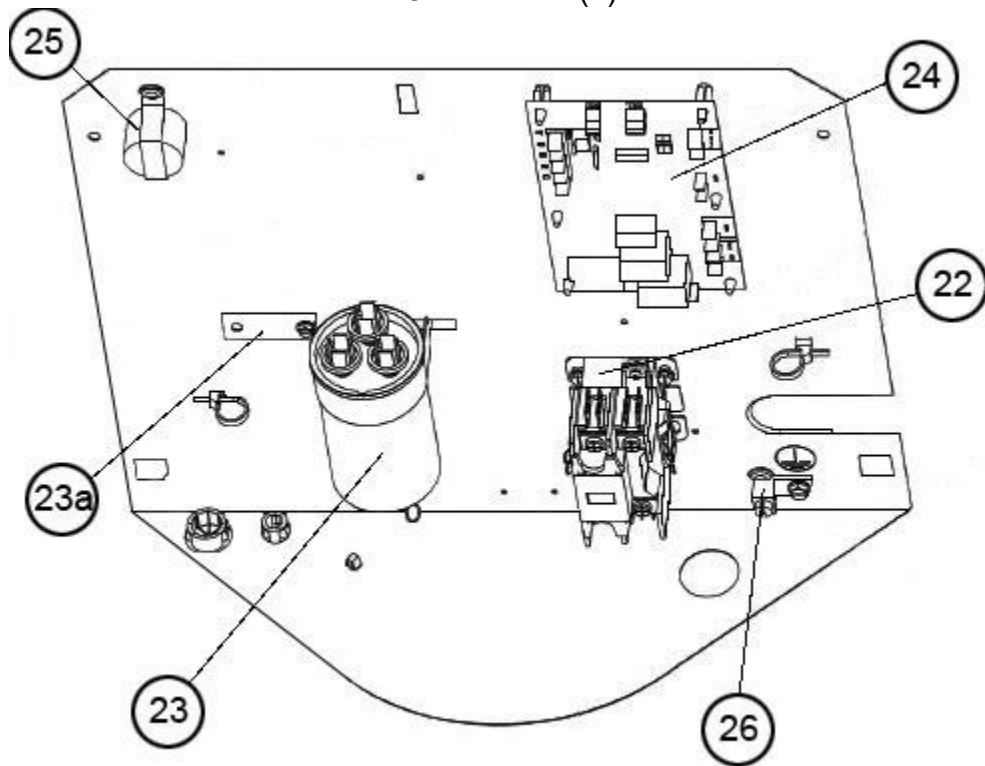

Control Box (2)

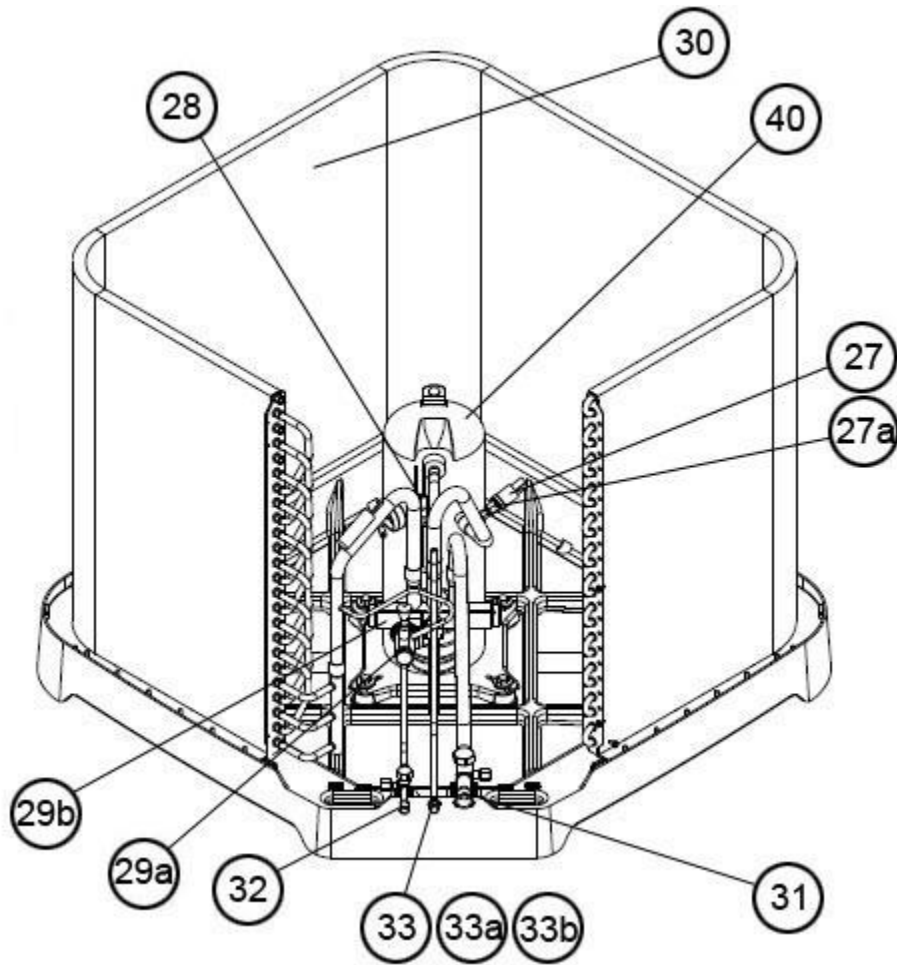

Valve Mounting, Compressor

NOTES

Stk It is recommended that stock be maintained for this part.

N/A Not Applicable

- 1 For units produced before W5120, when replacing the grille assembly you will also need to replace the grille center cap at the same time

DISCLAIMER: This document is intended to provide general replacement parts information to aid qualified service personnel in the repair of these models. The complete Model and Serial Number of the unit under repair should be specified when selecting and ordering replacement parts. Specifications and illustrations are subject to change without notice. Document 92-42800-RP15 supersedes all previous parts lists for these models. See <http://www.rheempartslists.net/92-42800-RP15> for the latest revision of this document. The manufacturer assumes no obligation for errors or omissions. Service personnel must verify the proper and safe operation of equipment after the replacement of any original components.