



RKNL-C

Parts List
24-June-2021



*This parts list is current as of the above revision date.
See <http://www.rheempartslists.net/92-42800-RKNL-C.pdf> for the current revision.*

Package Gas-Electric - Commercial

Table of Contents

Model Explanation.....	Page 3
 Parts Numbers	
Panels - Miscellaneous (Granite-Steel Gray) 036-060.....	Page 4
Panels - Miscellaneous (Granite-Steel Gray) 072-151 (1)	Page 5
Panels - Miscellaneous (Granite-Steel Gray) 072-151 (2)	Page 6
Panels - Miscellaneous (Granite-Steel Gray) 180-300 (1)	Page 7
Panels - Miscellaneous (Granite-Steel Gray) 180-300 (2)	Page 8
Panels - Miscellaneous (Neutra Green) 036-060.....	Page 9
Panels - Miscellaneous (Neutra Green) 072-151 (1)	Page 10
Panels - Miscellaneous (Neutra Green) 072-151 (2)	Page 11
Panels - Miscellaneous (Neutra Green) 180-300 (1)	Page 12
Panels - Miscellaneous (Neutra Green) 180-300 (2)	Page 13
Electrical Group 036-060	Page 14
Electrical Group 072-151 (1)	Page 15
Electrical Group 072-151 (2)	Page 16
Electrical Group 072-151 (3)	Page 17
Electrical Group 180-300 (1)	Page 18
Electrical Group 180-300 (2)	Page 19
Electrical Group 0180-300 (3)	Page 20
Fan Group 036-060	Page 21
Fan Group 072-151	Page 22
Fan Group 180-300	Page 23
Blower Group 036-060	Page 24
Blower Group 072-151 (1)	Page 25
Blower Group 072-151 (2)	Page 26
Blower Group 180-300	Page 27
Coil Parts 036-060	Page 28
Coil Parts 072-151 (1)	Page 29
Coil Parts 072-151 (2)	Page 30
Coil Parts 180-300 Gray	Page 31
Coil Parts 180-300 Green	Page 32
Compressor Group 036-060	Page 33
Compressor Group 072-151 (1)	Page 34
Compressor Group 072-151 (2)	Page 35
Compressor Group 180-300	Page 36
Heat Exchanger-Burner Group 036-060	Page 37
Heat Exchanger-Burner Group 072-085	Page 38
Heat Exchanger-Burner Group 090-150(1)	Page 39
Heat Exchanger-Burner Group 090-150(2)	Page 40
Heat Exchanger-Burner Group 151	Page 41
Heat Exchanger-Burner Group 180	Page 42
Heat Exchanger-Burner Group 210	Page 43
Heat Exchanger-Burner Group 240	Page 44
Heat Exchanger-Burner Group 241	Page 45
Heat Exchanger-Burner Group 300	Page 46
Gas Controls	Page 47
Accessories 036-151	Page 48
Accessories 180-300	Page 49
Orifice Selection Chart.....	Page 50

Drawings/Photographs

Exploded View 036-060.....	Page 51
Top Panel View 036-060	Page 52
Blower Assembly - Belt Drive 036-060	Page 53
Control Box 036-060.....	Page 54
Blower Motor Mount Assembly - Belt Drive 030-060	Page 55
Coil Group Cut-away View 036-060	Page 56
Evaporator Coil - Filter Parts 036-060	Page 56
Heat Exchanger Assembly 036-060	Page 57
One Piece Burner Assembly 036-060	Page 57
Compressor - Refrigeration Group 036-060	Page 58
TXV Identification Guide	Page 59
Exploded View 072-151.....	Page 60
Exterior - Front 072-151	Page 61
Exterior - Back 072-151.....	Page 61
Filter-Coil Assembly 072-151	Page 62
Condenser Coil Assembly 072-151	Page 62
Heat Exchanger Assembly 072-151	Page 63
Front Panel Brackets 072-151.....	Page 63
Filter Frame Assembly 072-151	Page 64
Blower Assembly 072-151	Page 64
Control Box 072-151.....	Page 65
Low Voltage Shields 072-151	Page 66
Exterior - Front 180-300	Page 67
Exterior - Rear 180-300.....	Page 67
Base Pan Assembly 180-300	Page 68
Base Rail Assembly 180-300	Page 68
Front Panel Brackets 180-300.....	Page 69
Interior - Coil 180-300	Page 69
Heat Compartment 180-300	Page 70
Condenser Bulkhead 180-300	Page 70
Filter Frame - Low Voltage Shields 180-300	Page 71
Burner Assembly 180-300	Page 72
Control Box 180-300.....	Page 73

MODEL NUMBER EXPLANATION

R	K	N	L	-	C	0	9	0	C	L	1	5	E	A	A	C
1	2	3	4		5		6		7	8		9	10		11	12

- 1 TRADE NAME** **8 DRIVE PACKAGE**
 L = Belt Drive
- 2 K = PACKAGE GAS / ELECTRIC** **9 HEATING CAPACITY (MBH)**
 Commercial
 M = Belt Drive - High Static
 N = Belt Drive (085, 090)
- 3 EFFICIENCY DESIGNATION** **10 IGNITION SYSTEM**
 N = High Efficiency
 E = Electric Ignition
 X = Electric Ignition, NOx
- 4 DESIGN SERIES** **11 OPTION CODES**
 L = R-410A
 08 = 80,000
 10 = 100,000
 12 = 120,000
 13 = 135,000
 15 = 150,000
 22 = 220,000
 25 = 250,000
- 5 TECHNICAL VARIATION** **12 ECONOMIZER OPTIONS**
 30 = 300,000
 40 = 400,000
 A = No Economizer
 B = Single Enthalpy Economizer with Barometric Relief
 C = Single Enthalpy Economizer with Barometric Relief and Smoke Detector
- 6 COOLING CAPACITY (BTU/HR)**
 036 = 36,000
 042 = 42,000
 048 = 48,000
 060 = 60,000
 072/073 = 72,000
 085 = 85,000
 090 = 90,000
 102 = 102,000
 120 = 120,000
 150 = 150,000
 151 = 150,000
 180 = 180,000
 210 = 210,000
 240/241 = 240,000
 300 = 300,000
- 7 ELECTRICAL DESIGNATION**
 C = 208-230/3/60
 D = 460/3/50
 Y = 575/3/60

SERIAL NUMBER EXPLANATION (Units Produced before Nov. 2013)

2	P	A	1	2	3	4	A	D	A	A	F	0	5	0	9	0	0	0	1
(1)	(2)		(3)			(4)	(5)	(6)	(7)	(8)		(9)		(10)		(11)			

- (1) GAS CODE** **(7) TECHNOLOGY VARIATIONS**
- (2) BLOWER CONTROL BOARD** **(8) PLANT**
 F = Fort Smith, AR
- (3) COMPRESSOR IDENTIFICATION NUMBER** **(9) WEEK**
- (4) IGNITION DEVICE** **(10) YEAR**
- (5) INDUCER BLOWER** **(11) PRODUCTION NUMBER**
- (6) HEAT EXCHANGER**

SERIAL NUMBER EXPLANATION (Units Produced after Nov. 2013)

F	0	8	1	3	9	9	9	9
(1)	(2)		(3)			(4)		

- (1) PLANT CODE**
- (2) WEEK (DATE CODE)**
- (3) YEAR**
- (4) PRODUCTION NUMBER**

**Note: For Compressor Identification Number, see Compressor Code on Rating Plate
 For Gas Code, see Control System Gas Code on Rating Plate**

No.	Notes	MODEL TECHNICAL VARIATION COOLING CAPACITY HEATING CAPACITY	RKNL- C 036-060 08	RKNL- C 036-060 10	RKNL- C 036-060 12	RKNL- C 036-060 13
PANELS, MISCELLANEOUS PARTS (Granite Steel Gray - After F4411)						
1		Base Rail - Side (2)	AE-58900-01	AE-58900-01	AE-58900-01	AE-58900-01
2		Base Rail - Condenser End	AE-58901-01	AE-58901-01	AE-58901-01	AE-58901-01
3		Base Rail - Evaporator End	AE-58902-01	AE-58902-01	AE-58902-01	AE-58902-01
4		Outdoor Coil Base Pan	AS-59051-01H	AS-59051-01H	AS-59051-01H	AS-59051-01H
5		Indoor Coil Base Pan	AS-58910-05	AS-58910-05	AS-58910-05	AS-58910-05
7		Condenser Bulkhead (Does not include Limit Baffle or Tube Support Angles)	AS-103277-02	AS-103277-02	AS-103277-02	AS-103277-01
		Limit Baffle - Attached To Condenser Bulkhead	AE-58913-02	AE-58913-02	AE-58913-02	AE-58913-01
		Tube Support Angle - Attached To The Condenser. Bulkhead	AE-59139-01	AE-59139-01	AE-59139-01	AE-59139-01
8		Blower Bulkhead Assembly (Does not include Blower Extensions, Cover Plate, Insulation Retainer)	AS-103385-01	AS-103385-01	AS-103385-01	AS-103385-01
		Tube Support Angle (Small piece attached to the Blower Bulkhead)	AE-59139-02	AE-59139-02	AE-59139-02	AE-59139-02
9		Blower Extension - Front	AE-58928-01	AE-58928-01	AE-58928-01	AE-58928-01
10		Blower Extension - Back	AE-58928-02	AE-58928-02	AE-58928-02	AE-58928-02
		Insulation Retainer	AE-59059-01	AE-59059-01	AE-59059-01	AE-59059-01
11		Wire Chase Insulation Assembly	AS-103291-01	AS-103291-01	AS-103291-01	AS-103291-01
12a		Corner Post (2)	AS-58965-01H	AS-58965-01H	AS-58965-01H	AS-58965-01H
12b		Center Post	AS-58966-01H	AS-58966-01H	AS-58966-01H	AS-58966-01H
14		Louvered Panel	AS-59028-01H	AS-59028-01H	AS-59028-01H	AS-59028-01H
15		Louvered Panel	AS-59028-03H	AS-59028-03H	AS-59028-03H	AS-59028-03H
16		Louvered Panel	AS-59028-02H	AS-59028-02H	AS-59028-02H	AS-59028-02H
17		Return/Supply Cover Assembly (2)	AS-58992-01H	AS-58992-01H	AS-58992-01H	AS-58992-01H
18		Rear Panel (Includes Insulation, Filler Panel, and Stripping)	AS-58976-01H	AS-58976-01H	AS-58976-01H	AS-58976-01H
19		Filler Panel - Return Air	AE-58974-01	AE-58974-01	AE-58974-01	AE-58974-01
		Filler Panel Stripping	AE-58897-10	AE-58897-10	AE-58897-10	AE-58897-10
20		Blower/Filter Access Panels (2)	AS-58990-01H	AS-58990-01H	AS-58990-01H	AS-58990-01H
21		Post - Left End	AS-58973-01H	AS-58973-01H	AS-58973-01H	AS-58973-01H
22		Front Panel Assembly	AS-59132-01H	AS-59132-01H	AS-59132-01H	AS-59132-01H
23		Grommet	56-22114-06	56-22114-06	56-22114-06	56-22114-06
24		Heating Compartment Access Panel	AS-58988-02H	AS-58988-02H	AS-58988-02H	AS-58988-02H
25		Flue Hood	AS-58882-01	AS-58882-01	AS-58882-01	AS-58882-01
		Flue Hood Gasket	68-23680-03	68-23680-03	68-23680-03	68-23680-03
		Mounting Panel - External Disconnect	AE-59133-01	AE-59133-01	AE-59133-01	AE-59133-01
26		Control Box Access Door	AS-103284-01H	AS-103284-01H	AS-103284-01H	AS-103284-01H
27a		Control Box Insert Panel	AS-103283-01H	AS-103283-01H	AS-103283-01H	AS-103283-01H
27b		Disconnect Plate	AS-90756-05H	AS-90756-05H	AS-90756-05H	AS-90756-05H
27c		Receptacle Plate	AS-90756-02H	AS-90756-02H	AS-90756-02H	AS-90756-02H
28		Front Post	AS-103288-01H	AS-103288-01H	AS-103288-01H	AS-103288-01H
29		Indoor Coil Top Panel Assembly	AS-58979-01H	AS-58979-01H	AS-58979-01H	AS-58979-01H
30a		Condenser Top Panel	AS-58981-01H	AS-58981-01H	AS-58981-01H	AS-58981-01H
30b		Support - Condenser Top Panel	AE-58980-01	AE-58980-01	AE-58980-01	AE-58980-01
32		Wire Grille	95-101660-01	95-101660-01	95-101660-01	95-101660-01
34		Control Box (w/o components)	AS-103281-01	AS-103281-01	AS-103281-01	AS-103281-01

No.	Notes	MODEL TECHNICAL VARIATION COOLING CAPACITY	RKNL- C 072	RKNL- C 073	RKNL- C 090	RKNL- C 102	RKNL- C 120	RKNL- C 150/151
PANELS - RAILS, BASE PANS, INSIDE CABINET (Granite/Steel Gray, After F4411)								
BASE RAILS:								
A		Base Rail - Front	AE-90575-15	AE-90575-15	AE-90575-15	AE-90575-15	AE-90575-15	AE-90575-15
B		Base Rail - Right	AE-90576-03	AE-90576-03	AE-90576-03	AE-90576-03	AE-90576-03	AE-90576-03
C		Base Rail - Rear	AE-90575-04	AE-90575-04	AE-90575-04	AE-90575-04	AE-90575-04	AE-90575-04
D		Base Rail - Left	AE-90576-04	AE-90576-04	AE-90576-04	AE-90576-04	AE-90576-04	AE-90576-04
BASE PANS:								
E		Outdoor Coil Base Pan	AS-90583-03H	AS-90583-03H	AS-90583-05H	AS-90583-05H	AS-90583-05H	AS-90577-14H
F		Indoor Coil Base Pan	AS-90577-12	AS-90577-12	AS-90577-12	AS-90577-12	AS-90577-12	AS-90577-12
INSIDE CABINET:								
G		Entry Plate	AE-90614-01	AE-90614-01	AE-90614-01	AE-90614-01	AE-90614-01	AE-90614-01
H		Entry Plate	AE-90614-01	AE-90614-01	AE-90614-01	AE-90614-01	AE-90614-01	AE-90614-01
J		Heat Compartment Side	AE-90598-07	AE-90598-07	AE-90598-07	AE-90598-07	AE-90598-07	AE-90598-07
K		Blower Deck	AS-90592-09	AS-90592-09	AS-90592-10	AS-90592-10	AS-90592-10	AS-90592-10
L		Wireway	AE-90718-05	AE-90718-05	AE-90718-05	AE-90718-05	AE-90718-05	AE-90718-05
M		Condenser Bulkhead	AS-90592-09	AS-90592-09	AS-90609-15	AS-90609-15	AS-90609-15	AS-90609-19

No.	Notes	MODEL TECHNICAL VARIATION COOLING CAPACITY	RKNL- C 072	RKNL- C 073	RKNL- C 090	RKNL- C 102	RKNL- C 120	RKNL- C 150/151
PANELS - FRONT (Granite/Steel Gray, After F4411)								
1		Control Box Door Assembly - w/Hinges, Latch, Gasket, Insulation	AS-102872-14H	AS-102872-14H	AS-102872-14H	AS-102872-14H	AS-102872-14H	AS-102872-14H
2a		Bracket - Top Panel (Left)	AS-102859-16H	AS-102859-16H	AS-102859-16H	AS-102859-16H	AS-102859-16H	AS-102859-16H
2b		Bracket - Top Panel (Center)	AS-102859-15H	AS-102859-15H	AS-102859-15H	AS-102859-15H	AS-102859-15H	AS-102859-15H
2c		Post - Blower Section	AS-102682-12H	AS-102682-12H	AS-102682-12H	AS-102682-12H	AS-102682-12H	AS-102682-12H
3a		Bracket - Bottom Panel (Left)	AS-102859-17H	AS-102859-17H	AS-102859-17H	AS-102859-17H	AS-102859-17H	AS-102859-17H
3b		Bracket - Blower/Heater Compartment	AS-102859-14H	AS-102859-14H	AS-102859-14H	AS-102859-14H	AS-102859-14H	AS-102859-14H
3c		Bracket - Bottom Panel (Right)	AS-102859-13H	AS-102859-13H	AS-102859-13H	AS-102859-13H	AS-102859-13H	AS-102859-13H
		Latch Assembly - Control Box Door (2)	64-102855-01	64-102855-01	64-102855-01	64-102855-01	64-102855-01	64-102855-01
4		Post Assembly - Indoor Coil Section	AS-90620-18H	AS-90620-18H	AS-90620-17H	AS-90620-17H	AS-90620-17H	AS-90620-17H
5		Control Box Cover	AE-90713-02	AE-90713-02	AE-90713-02	AE-90713-02	AE-90713-02	AE-90713-02
6		Control Mounting Plate	AE-90712-06	AE-90712-06	AE-90712-06	AE-90712-06	AE-90712-06	AE-90712-06
7a		Low Voltage Shield (Before F3512) - Upper Straight	AE-90742-08	AE-90742-08	AE-90742-08	AE-90742-08	AE-90742-08	AE-90742-08
7a		Low Voltage Shield (After F3512) - Upper Angled	AE-90742-12	AE-90742-12	AE-90742-12	AE-90742-12	AE-90742-12	AE-90742-12
7b		Low Voltage Shield (Before F3512) - Lower	AE-90742-03	AE-90742-03	AE-90742-03	AE-90742-03	AE-90742-03	AE-90742-03
7b		Low Voltage Shield (After F3512) - Lower	AE-90742-11	AE-90742-11	AE-90742-11	AE-90742-11	AE-90742-11	AE-90742-11
7c		Low Voltage Shield - Middle Strip	AE-90742-09	AE-90742-09	AE-90742-09	AE-90742-09	AE-90742-09	AE-90742-09
8		Control Box Back Insulation Assembly	AS-90601-06	AS-90601-06	AS-90601-06	AS-90601-06	AS-90601-06	AS-90601-06
9		Mounting Bracket	AE-90779-02	AE-90779-02	AE-90779-02	AE-90779-02	AE-90779-02	AE-90779-02
		Outlet Flue Hood	AS-102966-01	AS-102966-01	AS-102966-01	AS-102966-01	AS-102966-01	AS-102966-01
6		Inlet Flue Hood (2) - See Note 6	AE-90745-04	AE-90745-04	AE-90745-04	AE-90745-04	AE-90745-04	AE-90745-04
12	6	Gas Heat Access Panel Assembly - w/Hinges, Latch, Gasket, Insulation - See Note 6	AS-102872-20H	AS-102872-20H	AS-102872-20H	AS-102872-20H	AS-102872-20H	AS-102872-20H
		Latch Assembly - Electric Heat Door (2)	64-102855-01	64-102855-01	64-102855-01	64-102855-01	64-102855-01	64-102855-01
13		Gas Pipe Support Plate	AS-90774-10H	AS-90774-10H	AS-90774-10H	AS-90774-10H	AS-90774-10H	AS-90774-10H
14		Blower Access Panel Assembly - w/Hinges, Latch, Gasket, Insulation	AS-102872-16H	AS-102872-16H	AS-102872-16H	AS-102872-16H	AS-102872-16H	AS-102872-16H
		Latch Assembly - Blower Access Panel (3)	64-102855-01	64-102855-01	64-102855-01	64-102855-01	64-102855-01	64-102855-01
16		Heat Exchanger Mounting Frame Assembly	AS-90754-01	AS-90754-01	AS-90754-01	AS-90754-01	AS-90754-01	AS-90754-01
17		Condenser Coil Access Panel - Front	AS-90631-10H	AS-90631-10H	AS-90631-09H	AS-90631-09H	AS-90631-09H	AS-90631-11H
18		Front Corner Post	AS-90701-06H	AS-90701-06H	AS-90701-06H	AS-90701-06H	AS-90701-06H	AS-90701-05H

No.	Notes	MODEL TECHNICAL VARIATION COOLING CAPACITY	RKNL- C 072	RKNL- C 073	RKNL- C 090	RKNL- C 102	RKNL- C 120	RKNL- C 150/151	
PANELS - RIGHT, REAR AND LEFT SIDES (Granite/Steel Gray, After F4411)									
RIGHT:									
19		Air Stop	N/A	N/A	N/A	N/A	N/A	N/A	
20		Louver Panel Assembly	AS-90789-01H	AS-90789-01H	AS-90789-01H	AS-90789-01H	AS-90789-01H	N/A	
REAR:									
21		Rear Corner Post	AS-90702-03H	AS-90702-03H	AS-90702-03H	AS-90702-03H	AS-90702-03H	AS-90702-04H	
22		Condenser Coil Access Panel-Rear	AS-90631-03H	AS-90631-03H	AS-90631-05H	AS-90631-05H	AS-90631-05H	AS-90631-12H	
23		Rear Panel	AS-90618-02H	AS-90618-02H	AS-90618-02H	AS-90618-02H	AS-90618-02H	AS-90618-02H	
24		Supply Cover	AS-90626-02H	AS-90626-02H	AS-90626-02H	AS-90626-02H	AS-90626-02H	AS-90626-02H	
25		Return Cover	AS-90628-02H	AS-90628-02H	AS-90628-02H	AS-90628-02H	AS-90628-02H	AS-90628-02H	
LEFT:									
26		Upper Left Panel	AS-90624-03H	AS-90624-03H	AS-90624-03H	AS-90624-03H	AS-90624-03H	AS-90624-03H	
27		Lower Left Panel	AS-90624-04H	AS-90624-04H	AS-90624-04H	AS-90624-04H	AS-90624-04H	AS-90624-04H	
28		Left Corner Panel	AS-90755-07H	AS-90755-07H	AS-90755-07H	AS-90755-07H	AS-90755-07H	AS-90755-07H	
29		Plate - Receptacle	AS-90756-02H	AS-90756-02H	AS-90756-02H	AS-90756-02H	AS-90756-02H	AS-90756-02H	
30		Plate - Disconnect	AS-90756-03H	AS-90756-03H	AS-90756-03H	AS-90756-03H	AS-90756-03H	AS-90756-03H	
31		Button Plug (2)	45-22980-06	45-22980-06	45-22980-06	45-22980-06	45-22980-06	45-22980-06	
32		Button Plug	45-22980-05	45-22980-05	45-22980-05	45-22980-05	45-22980-05	45-22980-05	
TOP:									
33		Top Panel Assembly	AS-90775-38H	AS-90775-38H	AS-90775-38H	AS-90775-38H	AS-90775-38H	AS-90775-38H	
34		Condenser Top Panel	AS-90703-09H	AS-90703-09H	AS-90703-09H	AS-90703-09H	AS-90703-09H	AS-90703-08H	
35		Venturi	AS-90632-03H (2)	AS-90632-03H (2)	AS-90632-03H (2)	AS-90632-03H (2)	AS-90632-03H (2)	AS-90632-03H (2)	
36		Wire Grille	95-100906-09 (2)	95-100906-09 (2)	95-100906-09 (2)	95-100906-09 (2)	95-100906-09 (2)	95-100906-09 (2)	
43		Drain Pan - Removable	See Coil Group						

No.	Notes	MODEL TECHNICAL VARIATION COOLING CAPACITY	RKNL- C 180/210	RKNL- C 240	RKNL- C 241	RKNL- C 300
PANELS - RAILS, BASE PANS, INSIDE CABINET (Granite/Steel Gray, After F4411)						
BASE RAILS:						
A		Front	AS-90827-03	AS-90827-03	AS-90827-03	AS-90827-03
B		Right	AE-90576-06	AE-90576-06	AE-90576-06	AE-90576-06
C		Rear	AS-90827-04	AS-90827-04	AS-90827-04	AS-90827-04
D		Left	AE-90576-05	AE-90576-05	AE-90576-05	AE-90576-05
BASE PANS:						
E		Outdoor Base Pan	AS-90583-09H	AS-90583-09H	AS-90583-09	AS-90583-09H
F		Indoor Coil Base Pan - Return Air	AS-90577-09	AS-90577-09	AS-90577-09	AS-90577-09
G		Indoor Coil Base Pan - Supply Air	AS-90577-10	AS-90577-10	AS-90577-10	AS-90577-10
INSIDE CABINET PANEL/PIECES:						
H1		Entry Plate	AE-90614-01	AE-90614-01	AE-90614-01	AE-90614-01
H2		Entry Plate - Rooftop	AE-90614-01	AE-90614-01	AE-90614-01	AE-90614-01
I		Post - Blower Section	AS-102682-07H	AS-102682-07H	AE-102682-07H T	AS-102682-07H
J		Heat Compartment Side	AE-90598-06	AE-90598-06	AE-90598-06	AE-90598-06
K		Blower Deck Assembly	AS-90592-08	AS-90592-08	AS-90592-08	AS-90592-08
L		Wireway	AE-90718-04	AE-90718-04	AE-90718-04	AE-90718-04
M		Condenser Bulkhead	AS-90609-13	AS-90609-13	AS-90609-13	AS-90609-13
N		Divider Panel - Between Coils	AE-90735-05	AE-90735-05	AE-90735-05	AE-90735-05
O		Bulkhead Support	AE-102725-01	AE-102725-01	AE-102725-01	AE-102725-01
P		Primary Drain Pan	AS-103030-02	AS-103030-02	AS-103030-02	AS-103030-02
		Air Stop - Outdoor Coil- Front	AE-90706-13	AE-90706-13	AE-90706-25	AE-90706-13
		Air Stop - Outdoor Coil- Rear	AE-90706-12	AE-90706-12	AE-90706-24	AE-90706-12
U		Coil Support Top	AE-102700-03	AE-102700-03	AE-102700-03	AE-102700-03
V		Angle - Tube Support (2)	AE-90600-02	AE-90600-02	AE-90600-02	AE-90600-02

No.	Notes	MODEL TECHNICAL VARIATION COOLING CAPACITY	RKNL- C 180/210	RKNL- C 240	RKNL- C 241	RKNL- C 300
PANELS - FRONT AND RIGHT SIDES (Granite/Steel Gray, After F4411)						
1		Control Box Door Assembly - w/Hinges, Latch, Gasket, Insulation	AS-102872-04H	AS-102872-04H	AS-102872-04H T	AS-102872-04H
2a		Bracket - Top Panel (Left)	AS-102859-01H	AS-102859-01H	AE-102859-01H T	AS-102859-01H
2b		Bracket - Top Panel (Center)	AS-102969-01H	AS-102969-01H	AS-102969-01H T	AS-102969-01H
2c		Post - Blower Section	AS-102682-07H	AS-102682-07H	AE-102682-07H T	AS-102682-07H
3a		Bracket - Bottom Panel (Left)	AS-102859-02H	AS-102859-02H	AE-102859-02H T	AS-102859-02H
3b		Bracket - Blower/Heater Compartment	AS-102859-04H	AS-102859-04H	AE-102859-04H T	AS-102859-04H
3c		Bracket - Bottom Panel (Right)	AS-102859-05H	AS-102859-05H	AE-102859-05H T	AS-102859-05H
4		Post Assembly - Indoor Coil Section	AS-90620-15H	AS-90620-15H	AS-90620-15HT	AS-90620-15H
5		Control Box Cover	AE-90713-05	AE-90713-05	AE-90713-05	AE-90713-05
6		Control Mounting Panel	AE-90712-05	AE-90712-05	AE-90712-05	AE-90712-05
7a		Low Voltage Shield - Control Box (Upper Right)	AE-90742-07	AE-90742-07	AE-90742-07	AE-90742-07
7b		Low Voltage Shield - Control Box (Lower Left)	AE-90742-06	AE-90742-06	AE-90742-06	AE-90742-06
7c		Thermostat Chase Cover	AE-102722-01	AE-102722-01	AE-102722-01	AE-102722-01
8		Control Box Back	AS-90601-05	AS-90601-05	AS-90601-05	AS-90601-05
9		Mounting Bracket	AE-90779-02	AE-90779-02	AE-90779-02	AE-90779-02
		Outlet Flue Hood	AS-102966-01	AS-102966-01	AS-102966-01	AS-102966-01
	6	Inlet Flue Hood (2) - See Note 6	AE-90745-04	AE-90745-04	AE-90745-04	AE-90745-04
12	6	Gas Heat Access Panel Assembly - w/Hinges, Latch, Gasket, Insulation (025, 030) - See Note 6	AS-102872-11H	AS-102872-11H	AS-102872-12H T	AS-102872-12H
12	6	Gas Heat Access Panel Assembly - w/Hinges, Latch, Gasket, Insulation (035, 040) - See Note 6	AS-102872-12H	AS-102872-12H	AS-102872-10H T	AS-102872-10H
13		Power Entry Plate Assembly	AS-90774-12H	AS-90774-12H	AS-90774-12HT	AS-90774-12H
14		Blower Access Panel Assembly - w/Hinges, Latch, Gasket, Insulation	AS-102872-02H	AS-102872-02H	AS-102872-02H T	AS-102872-02H
16		Mounting Frame - Heat Exchanger Frame	AS-90754-03	AS-90754-03	AS-90754-03	AS-90754-03
17		Condenser Coil Access Panel - Front	AS-90734-08H	AS-90734-08H	AE-90734-20HT	AS-90734-08H
38c		Post - Outdoor Coil (Front)	See Coil Group			
39c		Post - Outdoor Coil (Rear)	See Coil Group			
		Louver Panel (Hail Guard) - Left	AS-90789-10H	AS-90789-10H	AS-90789-10H	AS-90789-10H
		Louver Panel (Hail Guard) - Right	AS-90789-09H	AS-90789-09H	AS-90789-09H	AS-90789-09H

No.	Notes	MODEL TECHNICAL VARIATION COOLING CAPACITY	RKNL- C 180/210	RKNL- C 240	RKNL- C 241	RKNL- C 300
PANELS - REAR, LEFT, AND TOP (Granite/Steel Gray, After F4411)						
REAR:						
22		Condenser Coil Access Panel-Rear	AS-90734-09H	AS-90734-09H	AE-90734-21HT	AS-90734-09H
23		Rear Panel - Right	AS-90618-08H	AS-90618-08H	AS-90618-08HT	AS-90618-08H
24		Supply Cover	AS-90628-03H	AS-90628-03H	AS-90628-03HT	AS-90628-03H
25		Return Cover	AS-90628-04H	AS-90628-04H	AS-90628-04HT	AS-90628-04H
LEFT:						
26		Upper Left Panel	AS-90624-09H	AS-90624-09H	AS-90624-09HT	AS-90624-09H
27		Lower Left Panel	AS-90624-08H	AS-90624-08H	AS-90624-08HT	AS-90624-08H
28		Left Corner Panel Assembly	AS-90755-05H	AS-90755-05H	AS-90755-05HT	AS-90755-05H
		Bracket - Left Corner Panel Assembly (2)	AE-90779-01	AE-90779-01	AE-90779-01	AE-90779-01
		Gasket for receptacle plate	68-42514-08	68-42514-08	68-42514-08	68-42514-08
		Gasket for disconnect plate	68-42514-09	68-42514-09	68-42514-09	68-42514-09
29		Plate - Install inside Panel-Receptacle	AS-90756-02H	AS-90756-02H	AE-90756-02HT	AS-90756-02H
30		Plate - Install inside Panel-Disconnect	AS-90756-03H	AS-90756-03H	AE-90756-03HT	AS-90756-03H
31		Button Plug (3)	45-42558-01	45-42558-01	45-42558-01	45-42558-01
32		Star Bushing (3)	45-18515-01	45-18515-01	45-18515-01	45-18515-01
TOP:						
33a		Top Panel Assembly - Right	AS-90616-04H	AS-90616-04H	AS-90616-04HT	AS-90616-04H
33b		Top Panel Assembly - Left	AS-90616-05H	AS-90616-05H	AS-90616-05HT	AS-90616-05H
34a		Top Panel - Front	AS-90633-10H	AS-90633-10H	AE-90633-10HT	AS-90633-10H
34b		Top Panel - Middle	AS-90633-12H	AS-90633-11H	AE-90633-11HT	AS-90633-11H
34c		Top Panel - Rear	AS-90633-09H	AS-90633-09H	AE-90633-09HT	AS-90633-09H
35		Venturi	AS-90632-03H (4)	AS-90632-03H (6)	AE-90632-03HT (6)	AS-90632-03H (6)
36		Wire Grille	95-100906-09 (4)	95-100906-09 (6)	95-100906-09 (6)	95-100906-09 (6)
43		Drain Pan - Removable	See Coil Group			

No.	Notes	MODEL TECHNICAL VARIATION COOLING CAPACITY HEATING CAPACITY	RKNL- C 036-060 08	RKNL- C 036-060 10	RKNL- C 036-060 12	RKNL- C 036-060 13
PANELS, MISCELLANEOUS PARTS (Neutra Green - Before F4411)						
1		Base Rail - Side (2)	AE-58900-01	AE-58900-01	AE-58900-01	AE-58900-01
2		Base Rail - Condenser End	AE-58901-01	AE-58901-01	AE-58901-01	AE-58901-01
3		Base Rail - Evaporator End	AE-58902-01	AE-58902-01	AE-58902-01	AE-58902-01
4		Outdoor Coil Base Pan	AS-59051-01A	AS-59051-01A	AS-59051-01A	AS-59051-01A
5		Indoor Coil Base Pan	AS-58910-05	AS-58910-05	AS-58910-05	AS-58910-05
7		Condenser Bulkhead (Does not include Limit Baffle or Tube Support Angles)	AS-103277-02	AS-103277-02	AS-103277-02	AS-103277-01
		Limit Baffle - Attached To Condenser Bulkhead	AE-58913-02	AE-58913-02	AE-58913-02	AE-58913-01
		Tube Support Angle - Attached To The Condenser. Bulkhead	AE-59139-01	AE-59139-01	AE-59139-01	AE-59139-01
8		Blower Bulkhead Assembly (Does not include Blower Extensions, Cover Plate, Insulation Retainer)	AS-103385-01	AS-103385-01	AS-103385-01	AS-103385-01
		Tube Support Angle (Small piece attached to the Blower Bulkhead)	AE-59139-02	AE-59139-02	AE-59139-02	AE-59139-02
9		Blower Extension - Front	AE-58928-01	AE-58928-01	AE-58928-01	AE-58928-01
10		Blower Extension - Back	AE-58928-02	AE-58928-02	AE-58928-02	AE-58928-02
		Insulation Retainer	AE-59059-01	AE-59059-01	AE-59059-01	AE-59059-01
11		Wire Chase Insulation Assembly	AS-103291-01	AS-103291-01	AS-103291-01	AS-103291-01
12a		Corner Post (2)	AS-58965-01A	AS-58965-01A	AS-58965-01A	AS-58965-01A
12b		Center Post	AS-58966-01A	AS-58966-01A	AS-58966-01A	AS-58966-01A
14		Louvered Panel	AS-59028-01A	AS-59028-01A	AS-59028-01A	AS-59028-01A
15		Louvered Panel	AS-59028-03A	AS-59028-03A	AS-59028-03A	AS-59028-03A
16		Louvered Panel	AS-59028-02A	AS-59028-02A	AS-59028-02A	AS-59028-02A
17		Return/Supply Cover Assembly	AS-58992-01A	AS-58992-01A	AS-58992-01A	AS-58992-01A
18		Rear Panel (Includes Insulation, Filler Panel, and Stripping)	AS-58976-01A	AS-58976-01A	AS-58976-01A	AS-58976-01A
19		Filler Panel - Return Air	AE-58974-01	AE-58974-01	AE-58974-01	AE-58974-01
		Filler Panel Stripping	AE-58897-10	AE-58897-10	AE-58897-10	AE-58897-10
20		Blower/Filter Access Panels (2)	AS-58990-01A	AS-58990-01A	AS-58990-01A	AS-58990-01A
21		Post - Left End	AS-58973-01A	AS-58973-01A	AS-58973-01A	AS-58973-01A
22		Front Panel Assembly	AS-59132-01A	AS-59132-01A	AS-59132-01A	AS-59132-01A
23		Grommet	56-22114-06	56-22114-06	56-22114-06	56-22114-06
24		Heating Compartment Access Panel	AS-58988-02A	AS-58988-02A	AS-58988-02A	AS-58988-02A
25		Flue Hood	AS-58882-01	AS-58882-01	AS-58882-01	AS-58882-01
		Flue Hood Gasket	68-23680-03	68-23680-03	68-23680-03	68-23680-03
		Mounting Panel - External Disconnect	AE-59133-01	AE-59133-01	AE-59133-01	AE-59133-01
26		Control Box Access Door	AS-103284-01A	AS-103284-01A	AS-103284-01A	AS-103284-01A
27a		Control Box Insert Panel	AS-103283-01A	AS-103283-01A	AS-103283-01A	AS-103283-01A
27b		Disconnect Plate	AS-90756-05A	AS-90756-05A	AS-90756-05A	AS-90756-05A
27c		Receptacle Plate	AS-90756-02A	AS-90756-02A	AS-90756-02A	AS-90756-02A
28		Front Post	AS-103288-01A	AS-103288-01A	AS-103288-01A	AS-103288-01A
29		Indoor Coil Top Panel Assembly	AS-58979-01A	AS-58979-01A	AS-58979-01A	AS-58979-01A
30a		Condenser Top Panel	AS-58981-01A	AS-58981-01A	AS-58981-01A	AS-58981-01A
30b		Support - Condenser Top Panel	AE-58980-01	AE-58980-01	AE-58980-01	AE-58980-01
32		Wire Grille	95-101660-01	95-101660-01	95-101660-01	95-101660-01
34		Control Box (w/o components)	AS-103281-01	AS-103281-01	AS-103281-01	AS-103281-01

No.	Notes	MODEL TECHNICAL VARIATION COOLING CAPACITY	RKNL- C 072	RKNL- C 085	RKNL- C 090	RKNL- C 102	RKNL- C 120	RKNL- C 150/151
PANELS - RAILS, BASE PANS, INSIDE CABINET (Neutra Green, Before F4411)								
BASE RAILS:								
A		Base Rail - Front	AE-90575-15	AE-90575-15	AE-90575-15	AE-90575-15	AE-90575-15	AE-90575-15
B		Base Rail - Right	AE-90576-03	AE-90576-03	AE-90576-03	AE-90576-03	AE-90576-03	AE-90576-03
C		Base Rail - Rear	AE-90575-04	AE-90575-04	AE-90575-04	AE-90575-04	AE-90575-04	AE-90575-04
D		Base Rail - Left	AE-90576-04	AE-90576-04	AE-90576-04	AE-90576-04	AE-90576-04	AE-90576-04
BASE PANS:								
E		Outdoor Coil Base Pan	AS-90583-03A	AS-90583-05A	AS-90583-05A	AS-90583-05A	AS-90583-05A	AS-90577-14A
F		Indoor Coil Base Pan	AS-90577-12	AS-90577-12	AS-90577-12	AS-90577-12	AS-90577-12	AS-90577-12
INSIDE CABINET:								
G		Entry Plate	AE-90614-01	AE-90614-01	AE-90614-01	AE-90614-01	AE-90614-01	AE-90614-01
H		Entry Plate	AE-90614-01	AE-90614-01	AE-90614-01	AE-90614-01	AE-90614-01	AE-90614-01
J		Heat Compartment Side	AE-90598-07	AE-90598-07	AE-90598-07	AE-90598-07	AE-90598-07	AE-90598-07
K		Blower Deck	AS-90592-09	AS-90592-10	AS-90592-10	AS-90592-10	AS-90592-10	AS-90592-10
L		Wireway	AE-90718-05	AE-90718-05	AE-90718-05	AE-90718-05	AE-90718-05	AE-90718-05
M		Condenser Bulkhead	AS-90592-09	AS-90609-20	AS-90609-15	AS-90609-15	AS-90609-15	AS-90609-19

No.	Notes	MODEL TECHNICAL VARIATION COOLING CAPACITY	RKNL- C 072	RKNL- C 085	RKNL- C 090	RKNL- C 102	RKNL- C 120	RKNL- C 150/151
PANELS - FRONT (Neutra Green, Before F4411)								
1		Control Box Door Assembly - w/Hinges, Latch, Gasket, Insulation	AS-102872-14A	AS-102872-14A	AS-102872-14A	AS-102872-14A	AS-102872-14A	AS-102872-14A
2a		Bracket - Top Panel (Left)	AS-102859-16A	AS-102859-16A	AS-102859-16A	AS-102859-16A	AS-102859-16A	AS-102859-16A
2b		Bracket - Top Panel (Center)	AS-102859-15A	AS-102859-15A	AS-102859-15A	AS-102859-15A	AS-102859-15A	AS-102859-15A
2c		Post - Blower Section	AS-102682-12A	AS-102682-12A	AS-102682-12A	AS-102682-12A	AS-102682-12A	AS-102682-12A
3a		Bracket - Bottom Panel (Left)	AS-102859-17A	AS-102859-17A	AS-102859-17A	AS-102859-17A	AS-102859-17A	AS-102859-17A
3b		Bracket - Blower/Heater Compartment	AS-102859-14A	AS-102859-14A	AS-102859-14A	AS-102859-14A	AS-102859-14A	AS-102859-14A
3c		Bracket - Bottom Panel (Right)	AS-102859-13A	AS-102859-13A	AS-102859-13A	AS-102859-13A	AS-102859-13A	AS-102859-13A
		Latch Assembly - Control Box Door (2)	64-102855-01	64-102855-01	64-102855-01	64-102855-01	64-102855-01	64-102855-01
4		Post Assembly - Indoor Coil Section	AS-90620-18A	AS-90620-18A	AS-90620-17A	AS-90620-17A	AS-90620-17A	AS-90620-17A
5		Control Box Cover	AE-90713-02	AE-90713-02	AE-90713-02	AE-90713-02	AE-90713-02	AE-90713-02
6		Control Mounting Plate	AE-90712-06	AE-90712-06	AE-90712-06	AE-90712-06	AE-90712-06	AE-90712-06
7a		Low Voltage Shield - Upper Straight	AE-90742-08	AE-90742-08	AE-90742-08	AE-90742-08	AE-90742-08	AE-90742-08
7b		Low Voltage Shield - Lower	AE-90742-03	AE-90742-03	AE-90742-03	AE-90742-03	AE-90742-03	AE-90742-03
7c		Low Voltage Shield - Middle Strip	AE-90742-09	AE-90742-09	AE-90742-09	AE-90742-09	AE-90742-09	AE-90742-09
8		Control Box Back Insulation Assembly	AS-90601-06	AS-90601-06	AS-90601-06	AS-90601-06	AS-90601-06	AS-90601-06
9		Mounting Bracket	AE-90779-02	AE-90779-02	AE-90779-02	AE-90779-02	AE-90779-02	AE-90779-02
		Outlet Flue Hood	AS-102966-01	AS-102966-01	AS-102966-01	AS-102966-01	AS-102966-01	AS-102966-01
	6	Inlet Flue Hood (2) - See Note 6	AE-90745-04	AE-90745-04	AE-90745-04	AE-90745-04	AE-90745-04	AE-90745-04
12	6	Gas Heat Access Panel Assembly - w/Hinges, Latch, Gasket, Insulation - See Note 6	AS-102872-20A	AS-102872-20A	AS-102872-20A	AS-102872-20A	AS-102872-20A	AS-102872-20A
		Latch Assembly - Electric Heat Door (2)	64-102855-01	64-102855-01	64-102855-01	64-102855-01	64-102855-01	64-102855-01
13		Gas Pipe Support Plate	AS-90774-10A	AS-90774-10A	AS-90774-10A	AS-90774-10A	AS-90774-10A	AS-90774-10A
14		Blower Access Panel Assembly - w/Hinges, Latch, Gasket, Insulation	AS-102872-16A	AS-102872-16A	AS-102872-16A	AS-102872-16A	AS-102872-16A	AS-102872-16A
		Latch Assembly - Blower Access Panel (3)	64-102855-01	64-102855-01	64-102855-01	64-102855-01	64-102855-01	64-102855-01
16		Heat Exchanger Mounting Frame Assembly	AS-90754-01	AS-90754-01	AS-90754-01	AS-90754-01	AS-90754-01	AS-90754-01
17		Condenser Coil Access Panel - Front	AS-90631-10A	AS-90631-09A	AS-90631-09A	AS-90631-09A	AS-90631-09A	AS-90631-11A
18		Front Corner Post	AS-90701-06A	AS-90701-06A	AS-90701-06A	AS-90701-06A	AS-90701-06A	AS-90701-05A

No.	Notes	MODEL TECHNICAL VARIATION COOLING CAPACITY	RKNL- C 072	RKNL- C 085	RKNL- C 090	RKNL- C 102	RKNL- C 120	RKNL- C 150/151	
PANELS - RIGHT, REAR AND LEFT SIDES (Neutra Green, Before F4411)									
RIGHT:									
19		Air Stop	N/A	N/A	N/A	N/A	N/A	N/A	
20		Louver Panel Assembly	AS-90789-01A	AS-90789-01A	AS-90789-01A	AS-90789-01A	AS-90789-01A	N/A	
REAR:									
21		Rear Corner Post	AS-90702-03A	AS-90702-03A	AS-90702-03A	AS-90702-03A	AS-90702-03A	AS-90702-04A	
22		Condenser Coil Access Panel-Rear	AS-90631-03A	AS-90631-05A	AS-90631-05A	AS-90631-05A	AS-90631-05A	AS-90631-12A	
23		Rear Panel	AS-90618-02A	AS-90618-02A	AS-90618-02A	AS-90618-02A	AS-90618-02A	AS-90618-02A	
24		Supply Cover	AS-90626-02A	AS-90626-02A	AS-90626-02A	AS-90626-02A	AS-90626-02A	AS-90626-02A	
25		Return Cover	AS-90628-02A	AS-90628-02A	AS-90628-02A	AS-90628-02A	AS-90628-02A	AS-90628-02A	
LEFT:									
26		Upper Left Panel	AS-90624-03A	AS-90624-03A	AS-90624-03A	AS-90624-03A	AS-90624-03A	AS-90624-03A	
27		Lower Left Panel	AS-90624-04A	AS-90624-04A	AS-90624-04A	AS-90624-04A	AS-90624-04A	AS-90624-04A	
28		Left Corner Panel	AS-90755-07A	AS-90755-07A	AS-90755-07A	AS-90755-07A	AS-90755-07A	AS-90755-07A	
29		Plate - Receptacle	AS-90756-02A	AS-90756-02A	AS-90756-02A	AS-90756-02A	AS-90756-02A	AS-90756-02A	
30		Plate - Disconnect	AS-90756-03A	AS-90756-03A	AS-90756-03A	AS-90756-03A	AS-90756-03A	AS-90756-03A	
31		Button Plug (2)	45-22980-06	45-22980-06	45-22980-06	45-22980-06	45-22980-06	45-22980-06	
32		Button Plug	45-22980-05	45-22980-05	45-22980-05	45-22980-05	45-22980-05	45-22980-05	
TOP:									
33		Top Panel Assembly	AS-90775-38A	AS-90775-38A	AS-90775-38A	AS-90775-38A	AS-90775-38A	AS-90775-38A	
34		Condenser Top Panel	AS-90703-09A	AS-90703-09A	AS-90703-09A	AS-90703-09A	AS-90703-09A	AS-90703-08A	
35		Venturi	AS-90632-03A (2)	AS-90632-03A (2)	AS-90632-03A (2)	AS-90632-03A (2)	AS-90632-03A (2)	AS-90632-03A (2)	
36		Wire Grille	95-100906-09 (2)	95-100906-09 (2)	95-100906-09 (2)	95-100906-09 (2)	95-100906-09 (2)	95-100906-09 (2)	
43		Drain Pan - Removable	See Coil Group						

No.	Notes	MODEL TECHNICAL VARIATION COOLING CAPACITY	RKNL- C 180/210	RKNL- C 240	RKNL- C 300
PANELS - RAILS, BASE PANS, INSIDE CABINET (Neutra Green, Before F4411)					
BASE RAILS:					
A		Front	AS-90827-03	AS-90827-03	AS-90827-03
B		Right	AE-90576-06	AE-90576-06	AE-90576-06
C		Rear	AS-90827-04	AS-90827-04	AS-90827-04
D		Left	AE-90576-05	AE-90576-05	AE-90576-05
BASE PANS:					
E		Outdoor Base Pan	AS-90583-09A	AS-90583-09A	AS-90583-09A
F		Indoor Coil Base Pan - Return Air	AS-90577-09	AS-90577-09	AS-90577-09
G		Indoor Coil Base Pan - Supply Air	AS-90577-10	AS-90577-10	AS-90577-10
INSIDE CABINET PANEL/PIECES:					
H1		Entry Plate	AE-90614-01	AE-90614-01	AE-90614-01
H2		Entry Plate - Rooftop	AE-90614-01	AE-90614-01	AE-90614-01
I		Post - Blower Section	AS-102682-07A	AS-102682-07A	AS-102682-07A
J		Heat Compartment Side	AE-90598-06	AE-90598-06	AE-90598-06
K		Blower Deck Assembly	AS-90592-08	AS-90592-08	AS-90592-08
L		Wireway	AE-90718-04	AE-90718-04	AE-90718-04
M		Condenser Bulkhead	AS-90609-13	AS-90609-13	AS-90609-13
N		Divider Panel - Between Coils	AE-90735-05	AE-90735-05	AE-90735-05
O		Bulkhead Support	AE-102725-01	AE-102725-01	AE-102725-01
P		Primary Drain Pan	AS-103030-02	AS-103030-02	AS-103030-02
		Air Stop - Outdoor Coil- Front	AE-90706-13	AE-90706-13	AE-90706-13
		Air Stop - Outdoor Coil- Rear	AE-90706-12	AE-90706-12	AE-90706-12
U		Coil Support Top	AE-102700-03	AE-102700-03	AE-102700-03
V		Angle - Tube Support (2)	AE-90600-02	AE-90600-02	AE-90600-02

No.	Notes	MODEL TECHNICAL VARIATION COOLING CAPACITY	RKNL- C 180/210	RKNL- C 240	RKNL- C 300
PANELS - FRONT AND RIGHT SIDES (Neutra Green, Before F4411)					
1		Control Box Door Assembly - w/Hinges, Latch, Gasket, Insulation	AS-102872-04A	AS-102872-04A	AS-102872-04A
2a		Bracket - Top Panel (Left)	AS-102859-01A	AS-102859-01A	AS-102859-01A
2b		Bracket - Top Panel (Center)	AS-102969-01A	AS-102969-01A	AS-102969-01A
2c		Post - Blower Section	AS-102682-07A	AS-102682-07A	AS-102682-07A
3a		Bracket - Bottom Panel (Left)	AS-102859-02A	AS-102859-02A	AS-102859-02A
3b		Bracket - Blower/Heater Compartment	AS-102859-04A	AS-102859-04A	AS-102859-04A
3c		Bracket - Bottom Panel (Right)	AS-102859-05A	AS-102859-05A	AS-102859-05A
4		Post Assembly - Indoor Coil Section	AS-90620-15A	AS-90620-15A	AS-90620-15A
5		Control Box Cover	AE-90713-05	AE-90713-05	AE-90713-05
6		Control Mounting Panel	AE-90712-05	AE-90712-05	AE-90712-05
7a		Low Voltage Shield - Control Box (Upper Right)	AE-90742-07	AE-90742-07	AE-90742-07
7b		Low Voltage Shield - Control Box (Lower Left)	AE-90742-06	AE-90742-06	AE-90742-06
7c		Thermostat Chase Cover	AE-102722-01	AE-102722-01	AE-102722-01
8		Control Box Back	AS-90601-05	AS-90601-05	AS-90601-05
9		Mounting Bracket	AE-90779-02	AE-90779-02	AE-90779-02
		Outlet Flue Hood	AS-102966-01	AS-102966-01	AS-102966-01
6		Inlet Flue Hood (2) - See Note 6	AE-90745-04	AE-90745-04	AE-90745-04
12	6	Gas Heat Access Panel Assembly - w/Hinges, Latch, Gasket, Insulation - See Note 6	AS-102872-11A	AS-102872-12A	AS-102872-12A
13		Power Entry Plate Assembly	AS-90774-12A	AS-90774-12A	AS-90774-12A
14		Blower Access Panel Assembly - w/Hinges, Latch, Gasket, Insulation	AS-102872-02A	AS-102872-02A	AS-102872-02A
16		Mounting Frame - Heat Exchanger Frame	AS-90754-03	AS-90754-03	AS-90754-03
17		Condenser Coil Access Panel - Front	AS-90734-08A	AS-90734-08A	AS-90734-08A
38c		Post - Outdoor Coil (Front)		See Coil Group	
39c		Post - Outdoor Coil (Rear)		See Coil Group	

No.	Notes	MODEL TECHNICAL VARIATION COOLING CAPACITY	RKNL- C 180/210	RKNL- C 240	RKNL- C 300
PANELS - REAR, LEFT, AND TOP (Neutra Green, Before F4411)					
REAR:					
22		Condenser Coil Access Panel-Rear	AS-90734-09A	AS-90734-09A	AS-90734-09A
23		Rear Panel - Right	AS-90618-08A	AS-90618-08A	AS-90618-08A
24		Supply Cover	AS-90628-03A	AS-90628-03A	AS-90628-03A
25		Return Cover	AS-90628-04A	AS-90628-04A	AS-90628-04A
LEFT:					
26		Upper Left Panel	AS-90624-09A	AS-90624-09A	AS-90624-09A
27		Lower Left Panel	AS-90624-08A	AS-90624-08A	AS-90624-08A
28		Left Corner Panel Assembly	AS-90755-05A	AS-90755-05A	AS-90755-05A
		Bracket - Left Corner Panel Assembly (2)	AE-90779-01	AE-90779-01	AE-90779-01
		Gasket for receptacle plate	68-42514-08	68-42514-08	68-42514-08
		Gasket for disconnect plate	68-42514-09	68-42514-09	68-42514-09
29		Plate - Install inside Panel-Receptacle	AS-90756-02A	AS-90756-02A	AS-90756-02A
30		Plate - Install inside Panel-Disconnect	AS-90756-03A	AS-90756-03A	AS-90756-03A
31		Button Plug (3)	45-42558-01	45-42558-01	45-42558-01
32		Star Bushing (3)	45-18515-01	45-18515-01	45-18515-01
TOP:					
33a		Top Panel Assembly - Right	AS-90616-04A	AS-90616-04A	AS-90616-04A
33b		Top Panel Assembly - Left	AS-90616-05A	AS-90616-05A	AS-90616-05A
34a		Top Panel - Front	AS-90633-10A	AS-90633-10A	AS-90633-10A
34b		Top Panel - Middle	AS-90633-12A	AS-90633-11A	AS-90633-11A
34c		Top Panel - Rear	AS-90633-09A	AS-90633-09A	AS-90633-09A
35		Venturi	AS-90632-03A (4)	AS-90632-03A (6)	AS-90632-03A (6)
36		Wire Grille	95-100906-09 (4)	95-100906-09 (6)	95-100906-09 (6)
43		Drain Pan - Removable	See Coil Group		

No.	Notes	MODEL TECHNICAL VARIATION COOLING CAPACITY ELECTRICAL DESIGNATION	RKNL- C 036-060 C	RKNL- C 036-060 D	RKNL- C 036-060 Y
ELECTRIC GROUP					
		Outlet Box	45-41952-02	45-41952-02	45-41952-02
		Receptacle Cover	45-41953-02	45-41953-02	45-41953-02
		Receptacle - Ground Fault	45-41954-01	45-41954-01	45-41954-01
		Disconnect Switch	42-100650-01	42-100650-01	42-100650-01
44		Auxiliary Limit - Blower Extension	47-17359-30	47-17359-30	47-17359-30
	Stk	Pressure Switch	42-24335-20	42-24335-20	42-24335-20
		Pressure Switch Assembly - (Clogged Filter and Fan Proving)	42-103320-26	42-103320-26	42-103320-26
48	Stk	Inducer Blower Motor - Including Gasket	70-23641-01	70-23641-02	70-23641-01
49	Stk	Inducer Blower Motor Gasket	68-23643-01	68-23643-01	68-23643-01
50		Low Pressure Control	47-102240-03	47-102240-03	47-102240-03
51		High Pressure Control	47-23699-04	47-23699-04	47-23699-04
CONTROL BOX COMPONENTS:					
	Stk	Integrated Furnace Control	See Gas Controls		
37	Stk	Unit Controller (RTU-C)	47-102883-01	47-102883-01	47-102883-01
38	Stk	Belt Drive Blower Contactor	42-102664-08	42-22464-01	42-22464-01
		Ground Lug	45-19000-01	45-19000-01	45-19000-01
40	Stk	Compressor Contactor	See Compressor Group		
41		Capacitor - Fan Motor	See Fan Group		
42	Stk	Low Voltage Shield	AE-103285-01	AE-103285-01	AE-103285-01
43	Stk	Transformer	46-103324-01	46-103324-02	46-103324-01
52		Comfort Alert	42-101504-03	42-101504-03	42-101504-03
WIRING HARNESES:					
		Jumper - 7 Pin Connector (Unit Configuration)	45-42522-110	45-42522-110	45-42522-110
		Wiring Harness - Economizer (8 Pin and 9 Pin) to (12 Pin, 4 Pin, 4 Connectors, and 2 Sensors) - See Note 7	45-42522-107	45-42522-107	45-42522-107
		Wiring Harness - Compressor Control, 14 Pin to (two 2 Pin Connectors and 2 Sensors) - See Note 7	45-42522-111	45-42522-111	45-42522-111
		Wiring Harness - IFC Communication (4 Pin to 4 Pin)	45-42522-95	45-42522-95	45-42522-95
		Wiring Harness - 12 Pin from IFC to 9 Connectors	AS-102393-04	AS-102393-04	AS-102393-04

No.	Notes	MODEL TECHNICAL VARIATION COOLING CAPACITY ELECTRICAL DESIGNATION	RKNL- C 072/073 C	RKNL- C 085 C	RKNL- C 090 C	RKNL- C 102 C	RKNL- C 120 C	RKNL- C 150/151 C
ELECTRICAL GROUP								
CONTROL BOX COMPONENTS:								
57a	Stk	Transformer - Control	46-42515-01	46-42515-01	46-42515-01	46-42515-01	46-42515-01	46-42515-01
58a		Double Row Terminal Block	45-42548-02	45-42548-02	45-42548-02	45-42548-02	45-42548-02	45-42548-02
58c		Ground Lug	45-19000-02	45-19000-02	45-19000-02	45-19000-02	45-19000-02	45-19000-02
59	Stk	Contactora - Blower	42-22464-01	42-22464-01	42-22464-01	42-22464-01	42-22464-01	42-22464-01
61a		Unit Controller (RTU-C)	47-102883-01	47-102883-01	47-102883-01	47-102883-01	47-102883-01	47-102883-01
		Comfort Alert	42-101504-03	42-101504-03	42-101504-03	42-101504-03	42-101504-03	42-101504-03
		Low Ambient Assembly	AS-103034-01	AS-103034-01	AS-103034-01	AS-103034-01	AS-103034-01	AS-103034-01
		Pressure Switch Assembly - (Clogged Filter and Fan Proving)	42-103320-26	42-103320-26	42-103320-26	42-103320-26	42-103320-26	42-103320-26
		Disconnect Switch Assembly	42-42559-02	42-42559-02	42-42559-02	42-42559-02	42-42559-02	42-42559-02
		Outlet Box	45-41952-02	45-41952-02	45-41952-02	45-41952-02	45-41952-02	45-41952-02
		Cover - Receptacle	45-41953-02	45-41953-02	45-41953-02	45-41953-02	45-41953-02	45-41953-02
		Receptacle/Ground Fault	45-41954-01	45-41954-01	45-41954-01	45-41954-01	45-41954-01	45-41954-01
60		Capacitor - Fan Motor	See Fan Group					
		High Pressure Control	See Coil Group					
		Low Pressure Control	See Coil Group					
61b	5	Integrated Furnace Control Board (IFC) - See Note 5	See Gas Controls					
62	Stk	Contactora - Compressor	42-22464-03 (1)	42-22464-03 (1)	42-22464-01 (2)	42-22464-01 (2)	42-22464-01 (2)	42-22464-01 (2)
WIRING HARNESES:								
		Temperature Sensors	See Note 7					
		Wiring Harness - Fan Motor #1	See Fan Group					
		Wiring Harness - Fan Motor #2	See Fan Group					
		Wiring Harness - Twist-Loc (12 Pin and 4 Pin) to 9 Pin	45-42522-100	45-42522-100	45-42522-100	45-42522-100	45-42522-100	45-42522-100
		Wiring Harness - 4 Pin to 4 Pin (IFC Communication)	45-42522-95	45-42522-95	45-42522-95	45-42522-95	45-42522-95	45-42522-95
7		Wiring Harness - 8 Pin to (4 Connectors and 2 Temperature Sensors) - See Note 7	45-42522-98	45-42522-98	45-42522-98	45-42522-98	45-42522-98	45-42522-98
		Jumper - 7 Pin Connector	45-42522-102	45-42522-102	45-42522-97	45-42522-97	45-42522-97	45-42522-97
7		Wiring Harness - Compressor Control (14 Pin to Two 2 Pin Connectors and Two Temperature Sensors) - See Note 7	45-42522-106	45-42522-106	N/A	N/A	N/A	N/A
7		Wiring Harness - Compressor Control (14 Pin to Four 2 Pin Connectors and Three Temperature Sensors) - See Note 7	N/A	N/A	45-42522-99	45-42522-99	45-42522-99	45-42522-99
		Wiring Harness - Twist-Loc (12 Pin to 3 Pin and 7 strip leads)	45-102706-06	45-102706-06	45-102706-06	45-102706-06	45-102706-06	45-102706-06
		Wiring Harness - Twist-Loc (12 Pin to 10 strip leads)	N/A	45-102706-10	45-102706-10	45-102706-10	45-102706-10	45-102706-10
		Plug Harness - Compressor	See Compressor Group					
		Wiring Harness - Induced Draft Blower	45-42522-19	45-42522-19	45-42522-19	45-42522-19	45-42522-19	45-42522-19
		Bypass Plug - Economizer 12 Pin	AS-61997-55	AS-61997-55	AS-61997-55	AS-61997-55	AS-61997-55	AS-61997-55

No.	Notes	MODEL TECHNICAL VARIATION COOLING CAPACITY ELECTRICAL DESIGNATION	RKNL- C 072/073 D	RKNL- C 085 D	RKNL- C 090 D	RKNL- C 102 D	RKNL- C 120 D	RKNL- C 150/151 D
ELECTRICAL GROUP								
CONTROL BOX COMPONENTS:								
57a	Stk	Transformer - Control	46-42515-02	46-42515-02	46-42515-02	46-42515-02	46-42515-02	46-42515-02
58a		Double Row Terminal Block	45-42548-02	45-42548-02	45-42548-02	45-42548-02	45-42548-02	45-42548-02
58c		Ground Lug	45-19000-02	45-19000-02	45-19000-02	45-19000-02	45-19000-02	45-19000-02
59	Stk	Contactora - Blower	42-22464-01	42-22464-01	42-22464-01	42-22464-01	42-22464-01	42-22464-01
61a		Unit Controller (RTU-C)	47-102883-01	47-102883-01	47-102883-01	47-102883-01	47-102883-01	47-102883-01
		Comfort Alert	42-101504-03	42-101504-03	42-101504-03	42-101504-03	42-101504-03	42-101504-03
		Low Ambient Assembly	AS-103034-01	AS-103034-01	AS-103034-01	AS-103034-01	AS-103034-01	AS-103034-01
		Pressure Switch Assembly - (Clogged Filter and Fan Proving)	42-103320-26	42-103320-26	42-103320-26	42-103320-26	42-103320-26	42-103320-26
		Disconnect Switch Assembly	42-42559-02	42-42559-02	42-42559-02	42-42559-02	42-42559-02	42-42559-02
		Outlet Box	45-41952-02	45-41952-02	45-41952-02	45-41952-02	45-41952-02	45-41952-02
		Cover - Receptacle	45-41953-02	45-41953-02	45-41953-02	45-41953-02	45-41953-02	45-41953-02
		Receptacle/Ground Fault	45-41954-01	45-41954-01	45-41954-01	45-41954-01	45-41954-01	45-41954-01
60		Capacitor - Fan Motor	See Fan Group					
		High Pressure Control	See Coil Group					
		Low Pressure Control	See Coil Group					
61b	5	Integrated Furnace Control Board (IFC) - See Note 5	See Gas Controls					
62	Stk	Contactora - Compressor	42-22464-03 (1)	42-22464-03 (1)	42-22464-01 (2)	42-22464-01 (2)	42-22464-01 (2)	42-22464-01 (2)
WIRING HARNESES:								
		Temperature Sensors	See Note 7					
		Wiring Harness - Fan Motor #1	See Fan Group					
		Wiring Harness - Fan Motor #2	See Fan Group					
		Wiring Harness - Twist-Loc (12 Pin and 4 Pin) to 9 Pin	45-42522-100	45-42522-100	45-42522-100	45-42522-100	45-42522-100	45-42522-100
		Wiring Harness - 4 Pin to 4 Pin (IFC Communication)	45-42522-95	45-42522-95	45-42522-95	45-42522-95	45-42522-95	45-42522-95
7		Wiring Harness - 8 Pin to (4 Connectors and 2 Temperature Sensors) - See Note 7	45-42522-98	45-42522-98	45-42522-98	45-42522-98	45-42522-98	45-42522-98
		Jumper - 7 Pin Connector	45-42522-102	45-42522-102	45-42522-97	45-42522-97	45-42522-97	45-42522-97
7		Wiring Harness - Compressor Control (14 Pin to Two 2 Pin Connectors and Two Temperature Sensors) - See Note 7	45-42522-106	45-42522-106	N/A	N/A	N/A	N/A
7		Wiring Harness - Compressor Control (14 Pin to Four 2 Pin Connectors and Three Temperature Sensors) - See Note 7	N/A	N/A	45-42522-99	45-42522-99	45-42522-99	45-42522-99
		Wiring Harness - Twist-Loc (12 Pin to 3 Pin and 7 strip leads)	45-102706-06	45-102706-06	45-102706-06	45-102706-06	45-102706-06	45-102706-06
		Wiring Harness - Twist-Loc (12 Pin to 10 strip leads)	N/A	45-102706-10	45-102706-10	45-102706-10	45-102706-10	45-102706-10
		Plug Harness - Compressor	See Compressor Group					
		Wiring Harness - Induced Draft Blower	45-42522-19	45-42522-19	45-42522-19	45-42522-19	45-42522-19	45-42522-19
		Bypass Plug - Economizer 12 Pin	AS-61997-55	AS-61997-55	AS-61997-55	AS-61997-55	AS-61997-55	AS-61997-55

No.	Notes	MODEL TECHNICAL VARIATION COOLING CAPACITY ELECTRICAL DESIGNATION	RKNL- C 072/073 Y	RKNL- C 085 Y	RKNL- C 090 Y	RKNL- C 102 Y	RKNL- C 120 Y	RKNL- C 150/151 Y
ELECTRICAL GROUP								
CONTROL BOX COMPONENTS:								
57a	Stk	Transformer - Control	46-42515-01	46-42515-01	46-42515-01	46-42515-01	46-42515-01	46-42515-01
57b	Stk	Transformer - Power Step Down (2)	46-23585-01	46-23585-01	46-23585-01	46-23585-01	46-23585-01	46-23585-01
58a		Double Row Terminal Block	45-42548-02	45-42548-02	45-42548-02	45-42548-02	45-42548-02	45-42548-02
58c		Ground Lug	45-19000-02	45-19000-02	45-19000-02	45-19000-02	45-19000-02	45-19000-02
59	Stk	Contactora - Blower	42-22464-01	42-22464-01	42-22464-01	42-22464-01	42-22464-01	42-22464-01
61a		Unit Controller (RTU-C)	47-102883-01	47-102883-01	47-102883-01	47-102883-01	47-102883-01	47-102883-01
		Comfort Alert	42-101504-03	42-101504-03	42-101504-03	42-101504-03	42-101504-03	42-101504-03
		Low Ambient Assembly	AS-103034-01	AS-103034-01	AS-103034-01	AS-103034-01	AS-103034-01	AS-103034-01
		Pressure Switch Assembly - (Clogged Filter and Fan Proving)	42-103320-26	42-103320-26	42-103320-26	42-103320-26	42-103320-26	42-103320-26
		Disconnect Switch Assembly	42-42559-02	42-42559-02	42-42559-02	42-42559-02	42-42559-02	42-42559-02
		Outlet Box	45-41952-02	45-41952-02	45-41952-02	45-41952-02	45-41952-02	45-41952-02
		Cover - Receptacle	45-41953-02	45-41953-02	45-41953-02	45-41953-02	45-41953-02	45-41953-02
		Receptacle/Ground Fault	45-41954-01	45-41954-01	45-41954-01	45-41954-01	45-41954-01	45-41954-01
60		Capacitor - Fan Motor	See Fan Group					
		High Pressure Control	See Coil Group					
		Low Pressure Control	See Coil Group					
61b	5	Integrated Furnace Control Board (IFC) - See Note 5	See Gas Controls					
62	Stk	Contactora - Compressor	42-22464-03 (1)	42-22464-03 (1)	42-22464-01 (2)	42-22464-01 (2)	42-22464-01 (2)	42-22464-01 (2)
WIRING HARNESES:								
		Temperature Sensors	See Note 7					
		Wiring Harness - Fan Motor #1	See Fan Group					
		Wiring Harness - Fan Motor #2	See Fan Group					
		Wiring Harness - Twist-Loc (12 Pin and 4 Pin) to 9 Pin	45-42522-100	45-42522-100	45-42522-100	45-42522-100	45-42522-100	45-42522-100
		Wiring Harness - 4 Pin to 4 Pin (IFC Communication)	45-42522-95	45-42522-95	45-42522-95	45-42522-95	45-42522-95	45-42522-95
7		Wiring Harness - 8 Pin to (4 Connectors and 2 Temperature Sensors) - See Note 7	45-42522-98	45-42522-98	45-42522-98	45-42522-98	45-42522-98	45-42522-98
		Jumper - 7 Pin Connector	45-42522-102	45-42522-102	45-42522-97	45-42522-97	45-42522-97	45-42522-97
7		Wiring Harness - Compressor Control (14 Pin to Four 2 Pin Connectors and Three Temperature Sensors) - See Note 7	45-42522-106	45-42522-106	N/A	N/A	N/A	N/A
7		Wiring Harness - Compressor Control (14 Pin to Four 2 Pin Connectors and Three Temperature Sensors) - See Note 7	N/A	N/A	45-42522-99	45-42522-99	45-42522-99	45-42522-99
		Wiring Harness - Twist-Loc (12 Pin to 3 Pin and 7 strip leads)	45-102706-06	45-102706-06	N/A	45-102706-06	45-102706-06	N/A
		Wiring Harness - Twist-Loc (12 Pin to 10 strip leads)	N/A	45-102706-10	45-102706-10	45-102706-10	45-102706-10	45-102706-10
		Plug Harness - Compressor	See Compressor Group					
		Wiring Harness - Induced Draft Blower	45-42522-19	45-42522-19	45-42522-19	45-42522-19	45-42522-19	45-42522-19
		Bypass Plug - Economizer 12 Pin	AS-61997-55	AS-61997-55	AS-61997-55	AS-61997-55	AS-61997-55	AS-61997-55

No.	Notes	MODEL TECHNICAL VARIATION COOLING CAPACITY ELECTRICAL DESIGNATION	RKNL- C 180/210 C	RKNL- C 240 C	RKNL- C 241 C	RKNL- C 300 C
ELECTRIC GROUP						
CONTROL BOX COMPONENTS:						
57a	Stk	Transformer - Control	46-42515-04	46-42515-04	46-42515-04	46-42515-04
58a		Terminal Block - Double Row	45-42548-02	45-42548-02	45-42548-02	45-42548-02
58b		Terminal Block	45-21134-04	45-21134-04	45-21134-04	45-21134-04
58c		Ground Lug	45-19000-02	45-19000-02	45-19000-02	45-19000-02
59	Stk	Contactora - Blower	42-102664-08	42-102664-08	42-102664-08	42-102664-08
59a	Stk	Pressure Switch Assembly - (Clogged Filter and Fan Proving)	42-103320-26	42-103320-26	42-103320-28	42-103320-26
	Stk	Pressure Switch - Draft Inducer (.35 inch WC)	42-24335-23	42-24335-23	42-105601-25	42-24335-23
	Stk	Pressure Switch - Draft Inducer (.20 inch WC)	42-24335-24	42-24335-24	42-105601-24	42-24335-24
	Stk	Pressure Switch - Draft Inducer (.45 inch WC)	N/A	N/A	42-105601-21	N/A
		Disconnect Switch Assembly	42-42559-02	42-42559-02	42-42559-02	42-42559-02
		Outlet Box	45-41952-02	45-41952-02	45-41952-02	45-41952-02
		Cover - Receptacle	45-41953-02	45-41953-02	45-41953-04	45-41953-02
		Receptacle/Ground Fault	45-41954-01	45-41954-01	45-41954-01	45-41954-01
		Comfort Alert (2)	42-101504-03	42-101504-03	42-101504-03	42-101504-03
		Low Ambient Assembly (2)	AS-103034-01	AS-103034-01	AS-103034-01	AS-103034-01
60		Run Capacitor	See Fan Group			
		High Pressure Control	See Coil Group			
		Low Pressure Control	See Coil Group			
61a		Unit Controller (RTU-C)	47-102883-01	47-102883-01	47-102883-02	47-102883-01
61b		Integrated Furnace Control	See Gas Controls			
62a	Stk	Compressor #1 Contactor	42-102664-12	42-102664-12	42-102664-26	42-22464-04
62b	Stk	Compressor #2 Contactor	42-102664-12	42-22464-04	42-102664-12	42-22464-04
WIRING HARNESES:						
		Temperature Sensors	See Note 7			
		Wiring Harness - Motor #1	See Fan Group			
		Wiring Harness - Motor #2	See Fan Group			
		Wiring Harness - 4 Pin to 4 Pin (IFC Communication)	45-42522-95	45-42522-95	45-42522-95	45-42522-95
7		Wiring Harness - 8 Pin to 4 Connectors and 2 Temperature Sensors - See Note 7	45-42522-98	45-42522-98	45-42522-98	45-42522-98
		Jumper - 7 Pin Connector (Unit Configuration)	45-42522-97	45-42522-97	45-42522-97	45-42522-97
7		Wiring Harness - Compressor Control (14 Pin to Four 2 Pin Connectors and Three Temperature Sensors) - See Note 7	45-42522-78	45-42522-78	45-42522-78	45-42522-78
		Wiring Harness - Twist-Loc, Economizer (12 Pin and 4 Pin to 9 Pin)	45-42522-93	45-42522-93	45-42522-93	45-42522-93
		Plug Harness - Compressor	See Compressor Group			
		Bypass Plug - Economizer 12 Pin	AS-61997-55	AS-61997-55	45-61997-55	AS-61997-55
		Wiring Harness - Induced Draft Blower (25E)	45-42522-87	N/A	N/A	N/A
		Wiring Harness - Induced Draft Blower (30E,35E)	45-42522-86	45-42522-86	45-42522-86	45-42522-86
		Wiring Harness - Induced Draft Blower (40E)	N/A	45-42522-90	45-42522-90	45-42522-90
		Wiring Harness - Furnace Control (12 pin to 12 wire leads - Twist Loc)	45-42522-88	45-42522-88	45-42522-88	45-42522-88

No	Notes	MODEL TECHNICAL VARIATION COOLING CAPACITY ELECTRICAL DESIGNATION	RKNL- C 180/210 D	RKNL- C 240 D	RKNL- C 241 D	RKNL- C 300 D
ELECTRIC GROUP						
CONTROL BOX COMPONENTS:						
57	a	Stk Transformer - Control	46-42515-05	46-42515-05	46-42515-05	46-42515-05
58	a	Terminal Block - Double Row	45-42548-02	45-42548-02	45-42548-02	45-42548-02
58	b	Terminal Block	45-21134-04	45-21134-04	45-21134-04	45-21134-04
58	c	Ground Lug	45-19000-02	45-19000-02	45-19000-02	45-19000-02
59	Stk	Contactor - Blower	42-102664-08	42-22464-01	42-102664-08	42-102664-08
59	a	Stk Pressure Switch Assembly - (Clogged Filter and Fan Proving)	42-103320-26	42-103320-26	42-103320-28	42-103320-26
	Stk	Pressure Switch - Draft Inducer (.35 inch WC)	42-24335-23	42-24335-23	42-105601-25	42-24335-23
	Stk	Pressure Switch - Draft Inducer (.20 inch WC)	42-24335-24	42-24335-24	42-105601-24	42-24335-24
	Stk	Pressure Switch (.45 inch WC)	N/A	N/A	42-105601-21	N/A
		Disconnect Switch Assembly	42-42559-02	42-42559-02	42-42559-02	42-42559-02
		Outlet Box	45-41952-02	45-41952-02	45-41952-02	45-41952-02
		Cover - Receptacle	45-41953-02	45-41953-02	45-41953-04	45-41953-02
		Receptacle/Ground Fault	45-41954-01	45-41954-01	45-41954-01	45-41954-01
		Comfort Alert (2)	42-101504-03	42-101504-03	42-101504-03	42-101504-03
		Low Ambient Assembly (2)	AS-103034-01	AS-103034-01	AS-103034-01	AS-103034-01
60		Run Capacitor	See Fan Group			
		High Pressure Control	See Coil Group			
		Low Pressure Control	See Coil Group			
61	a	Unit Controller (RTU-C)	47-102883-01	47-102883-01	47-102883-02	47-102883-01
61	b	Integrated Furnace Control	See Gas Controls			
62	a	Stk Compressor #1 Contactor	42-102664-12	42-102664-12	42-102664-26	42-22464-04
62	b	Stk Compressor #2 Contactor	42-102664-12	42-22464-04	42-102664-12	42-22464-04
WIRING HARNESES:						
		Temperature Sensors	See Note 7			
		Wiring Harness - Motor #1	See Fan Group			
		Wiring Harness - Motor #2	See Fan Group			
		Wiring Harness - 4 Pin to 4 Pin (IFC Communication)	45-42522-95	45-42522-95	45-42522-95	45-42522-95
	7	Wiring Harness - 8 Pin to 4 Connectors and 2 Temperature Sensors - See Note 7	45-42522-98	45-42522-98	45-42522-98	45-42522-98
		Jumper - 7 Pin Connector (Unit Configuration)	45-42522-97	45-42522-97	45-42522-97	45-42522-97
	7	Wiring Harness - Compressor Control (14 Pin to Four 2 Pin Connectors and Three Temperature Sensors) - See Note 7	45-42522-78	45-42522-78	45-42522-78	45-42522-78
		Wiring Harness - Twist-Loc, Economizer (12 Pin and 4 Pin to 9 Pin)	45-42522-93	45-42522-93	45-42522-93	45-42522-93
		Plug Harness - Compressor	See Compressor Group			
		Bypass Plug - Economizer 12 Pin	AS-61997-55	AS-61997-55	AS-61997-55	AS-61997-55
		Wiring Harness - Induced Draft Blower (25E)	45-42522-87	N/A	N/A	N/A
		Wiring Harness - Induced Draft Blower (30E,35E)	45-42522-86	45-42522-86	45-42522-86	45-42522-86
		Wiring Harness - Induced Draft Blower (40E)	N/A	45-42522-90	45-42522-90	45-42522-90
		Wiring Harness - Furnace Control (12 pin to 12 wire leads - Twist Loc)	45-42522-88	45-42522-88	45-42522-88	45-42522-88

No.	Notes	MODEL TECHNICAL VARIATION COOLING CAPACITY ELECTRICAL DESIGNATION	RKNL- C 180/210 Y	RKNL- C 240 Y	RKNL- C 241 Y	RKNL- C 300 Y
ELECTRIC GROUP						
CONTROL BOX COMPONENTS:						
57a	Stk	Transformer - Control	46-42515-04	46-42515-04	46-42515-04	46-42515-04
57b	Stk	Transformer - Power Step Down	46-23585-01 (2)	46-23585-01 (4)	46-23585-01 (4)	46-23585-01 (4)
58a		Terminal Block - Double Row	45-42548-02	45-42548-02	45-42548-02	45-42548-02
58b		Terminal Block	45-21134-04	45-21134-04	45-21134-04	45-21134-04
58c		Ground Lug	45-19000-02	45-19000-02	45-19000-02	45-19000-02
59	Stk	Contactator - Blower	42-102664-08	42-102664-08	42-102664-08	42-102664-08
59a	Stk	Pressure Switch Assembly - (Clogged Filter and Fan Proving)	42-103320-26	42-103320-26	42-103320-28	42-103320-26
	Stk	Pressure Switch - Draft Inducer (.35 inch WC)	42-24335-23	42-24335-23	42-105601-25	42-24335-23
	Stk	Pressure Switch - Draft Inducer (.20 inch WC)	42-24335-24	42-24335-24	42-105601-24	42-24335-24
		Disconnect Switch Assembly	42-42559-02	42-42559-02	42-42559-02	42-42559-02
		Outlet Box	45-41952-02	45-41952-02	45-41952-02	45-41952-02
		Cover - Receptacle	45-41953-02	45-41953-02	45-41953-04	45-41953-02
		Receptacle/Ground Fault	45-41954-01	45-41954-01	45-41954-01	45-41954-01
		Comfort Alert (2)	42-101504-03	42-101504-03	42-101504-03	42-101504-03
		Low Ambient Assembly (2)	AS-103034-01	AS-103034-01	AS-103034-01	AS-103034-01
60		Run Capacitor	See Fan Group			
		High Pressure Control	See Coil Group			
		Low Pressure Control	See Coil Group			
61a		Unit Controller (RTU-C)	47-102883-01	47-102883-01	47-102883-02	47-102883-01
61b		Integrated Furnace Control	See Gas Controls			
62a	Stk	Compressor #1 Contactor	42-102664-12	42-102664-12	42-102664-26	42-22464-04
62b	Stk	Compressor #2 Contactor	42-102664-12	42-22464-04	42-102664-12	42-22464-04
WIRING HARNESES:						
		Temperature Sensors	See Note 7			
		Wiring Harness - Motor #1	See Fan Group			
		Wiring Harness - Motor #2	See Fan Group			
		Wiring Harness - 4 Pin to 4 Pin (IFC Communication)	45-42522-95	45-42522-95	45-42522-95	45-42522-95
7		Wiring Harness - 8 Pin to 4 Connectors and 2 Temperature Sensors - See Note 7	45-42522-98	45-42522-98	45-42522-98	45-42522-98
		Jumper - 7 Pin Connector (Unit Configuration)	45-42522-97	45-42522-97	45-42522-97	45-42522-97
7		Wiring Harness - Compressor Control (14 Pin to Four 2 Pin Connectors and Three Temperature Sensors) - See Note 7	45-42522-78	45-42522-78	45-42522-78	45-42522-78
		Wiring Harness - Twist-Loc, Economizer (12 Pin and 4 Pin to 9 Pin)	45-42522-93	45-42522-93	45-42522-93	45-42522-93
		Plug Harness - Compressor	See Compressor Group			
		Bypass Plug - Economizer 12 Pin	AS-61997-55	AS-61997-55	45-61997-55	AS-61997-55
		Wiring Harness - Induced Draft Blower (25E)	N/A	N/A	N/A	N/A
		Wiring Harness - Induced Draft Blower (35E)	45-42522-86	N/A	N/A	N/A
		Wiring Harness - Induced Draft Blower (40E)	N/A	45-42522-90	45-42522-90	45-42522-90
		Wiring Harness - Furnace Control (12 pin to 12 wire leads - Twist Loc)	45-42522-88	45-42522-88	45-42522-88	45-42522-88
		High/Low Pressure Switch Assembly (Includes both Switches and Wiring Harness)	See Coil Group			

No.	Notes	MODEL TECHNICAL VARIATION COOLING CAPACITY ELECTRICAL DESIGNATION	RKNL- C 036 C	RKNL- C 042 C	RKNL- C 048 C	RKNL- C 060 C
FAN GROUP						
35	Stk	Fan Motor	51-100998-05	51-100998-05	51-100998-05	51-100998-13
36	Stk	Fan Blade	70-23594-01	70-23594-01	70-23594-01	70-42484-01
41	Stk	Capacitor - Fan Motor	43-100496-04	43-100496-04	43-100496-04	43-100496-12

No.	Notes	MODEL TECHNICAL VARIATION COOLING CAPACITY ELECTRICAL DESIGNATION	RKNL- C 036 D	RKNL- C 042 D	RKNL- C 048 D	RKNL- C 060 D
FAN GROUP						
35	Stk	Fan Motor	51-100998-07	51-100998-07	51-100998-07	51-100998-12
36	Stk	Fan Blade	70-23594-01	70-23594-01	70-23594-01	70-42484-01
41	Stk	Capacitor - Fan Motor	43-100496-04	43-100496-04	43-100496-04	43-100496-12

No.	Notes	MODEL TECHNICAL VARIATION COOLING CAPACITY ELECTRICAL DESIGNATION	RKNL- C 036 Y	RKNL- C 048 Y	RKNL- C 060 Y	
FAN GROUP						
35	Stk	Fan Motor	51-100998-14	51-100998-14	51-100998-14	
36	Stk	Fan Blade	70-23594-01	70-23594-01	70-42484-01	
41	Stk	Capacitor - Fan Motor	43-100496-11	43-100496-11	43-100496-11	

No.	Notes	MODEL TECHNICAL VARIATION COOLING CAPACITY ELECTRICAL DESIGNATION	RKNL- C 072 C	RKNL- C 073 C	RKNL- C 085 C	RKNL- C 090 C
FAN GROUP						
52	Stk	Fan Motor (2)	51-42534-24	51-42534-24	51-42534-24	51-42534-24
		Wiring Harness - Motor #1 (7 wire)	45-102706-01	45-102706-01	45-102706-01	45-102706-01
		Wiring Harness - Motor #2 (5 wire)	45-102706-02	45-102706-02	45-102706-02	45-102706-02
53	Stk	Fan Blade (2)	70-42572-04	70-42572-04	70-42572-04	70-42572-04
60	Stk	Capacitor - Fan Motor (2)	43-100496-12	43-100496-12	43-100496-12	43-100496-12

No.	Notes	MODEL TECHNICAL VARIATION COOLING CAPACITY ELECTRICAL DESIGNATION	RKNL- C 102 C	RKNL- C 120 C	RKNL- C 150 C	RKNL- C 151 C
FAN GROUP						
52	Stk	Fan Motor (2)	51-42534-24	51-42534-24	51-42534-29	51-42534-29
		Wiring Harness - Motor #1 (7 wire)	45-102706-01	45-102706-01	45-102706-03	45-102706-03
		Wiring Harness - Motor #2 (5 wire)	45-102706-02	45-102706-02	45-102706-04	45-102706-04
53	Stk	Fan Blade (2)	70-42572-04	70-42572-04	70-42502-03	70-103693-01
60	Stk	Capacitor - Fan Motor (2)	43-100496-12	43-100496-12	43-100496-17	43-100496-17

No.	Notes	MODEL TECHNICAL VARIATION COOLING CAPACITY ELECTRICAL DESIGNATION	RKNL- C 072 D	RKNL- C 073 D	RKNL- C 085 D	RKNL- C 090 D
FAN GROUP						
52	Stk	Fan Motor (2)	51-42534-25	51-42534-25	51-42534-25	51-42534-25
		Wiring Harness - Motor #1 (7 wire)	45-102706-01	45-102706-01	45-102706-01	45-102706-01
		Wiring Harness - Motor #2 (5 wire)	45-102706-02	45-102706-02	45-102706-02	45-102706-02
53	Stk	Fan Blade (2)	70-42572-04	70-42572-04	70-42572-04	70-42572-04
60	Stk	Capacitor - Fan Motor (2)	43-100496-12	43-100496-12	43-100496-12	43-100496-12

No.	Notes	MODEL TECHNICAL VARIATION COOLING CAPACITY ELECTRICAL DESIGNATION	RKNL- C 102 D	RKNL- C 120 D	RKNL- C 150 D	RKNL- C 151 D
FAN GROUP						
52	Stk	Fan Motor (2)	51-42534-25	51-42534-25	51-42534-28	51-42534-28
		Wiring Harness - Motor #1 (7 wire)	45-102706-01	45-102706-01	45-102706-03	45-102706-03
		Wiring Harness - Motor #2 (5 wire)	45-102706-02	45-102706-02	45-102706-04	45-102706-04
53	Stk	Fan Blade (2)	70-42572-04	70-42572-04	70-42502-03	70-103693-01
60	Stk	Capacitor - Fan Motor (2)	43-100496-12	43-100496-12	43-100496-12	43-100496-12

No.	Notes	MODEL TECHNICAL VARIATION COOLING CAPACITY ELECTRICAL DESIGNATION	RKNL- C 072 Y	RKNL- C 073 Y	RKNL- C 085 Y	RKNL- C 090 Y
FAN GROUP						
52	Stk	Fan Motor (2)	51-42534-26	51-42534-26	51-42534-26	51-42534-26
		Wiring Harness - Motor #1 (7 wire)	45-102706-01	45-102706-01	45-102706-01	45-102706-01
		Wiring Harness - Motor #2 (5 wire)	45-102706-02	45-102706-02	45-102706-02	45-102706-02
53	Stk	Fan Blade (2)	70-42572-04	70-42572-04	70-42572-04	70-42572-04
60	Stk	Capacitor - Fan Motor (2)	43-100496-12	43-100496-12	43-100496-12	43-100496-12

No.	Notes	MODEL TECHNICAL VARIATION COOLING CAPACITY ELECTRICAL DESIGNATION	RKNL- C 102 Y	RKNL- C 120 Y	RKNL- C 150 Y	RKNL- C 151 Y
FAN GROUP						
52	Stk	Fan Motor (2)	51-42534-26	51-42534-26	51-42534-27	51-42534-27
		Wiring Harness - Motor #1 (7 wire)	45-102706-01	45-102706-01	45-102706-03	45-102706-03
		Wiring Harness - Motor #2 (5 wire)	45-102706-02	45-102706-02	45-102706-04	45-102706-04
53	Stk	Fan Blade (2)	70-42572-04	70-42572-04	70-42502-03	70-103693-01
60	Stk	Capacitor - Fan Motor (2)	43-100496-12	43-100496-12	43-100496-48	43-100496-48

No.	Notes	MODEL TECHNICAL VARIATION COOLING CAPACITY ELECTRICAL DESIGNATION	RKNL- C 180/210 C	RKNL- C 240 C	RKNL- C 241 C	RKNL- C 300 C
FAN GROUP						
52	Stk	Fan Motor	51-42534-24 (4)	51-42534-24 (6)	51-42534-24 (6)	51-42534-24 (6)
		Wiring Harness - Motor #1 & #4	45-42522-71	45-42522-71	45-42522-71	45-42522-71
		Wiring Harness - Motor #2 & #5	N/A	45-42522-70	45-42522-70	45-42522-70
		Wiring Harness - Motor #3 & #6	45-42522-69	45-42522-69	45-42522-69	45-42522-69
53	Stk	Fan Blade	70-42572-04 (4)	70-42572-04 (6)	70-42572-04 (6)	70-42572-04 (6)
60	Stk	Capacitor - Fan Motor	43-100496-12 (4)	43-100496-12 (6)	43-100496-12 (6)	43-100496-12 (6)

No.	Notes	MODEL TECHNICAL VARIATION COOLING CAPACITY ELECTRICAL DESIGNATION	RKNL- C 180/210 D	RKNL- C 240 D	RKNL- C 241 D	RKNL- C 300 D
FAN GROUP						
52	Stk	Fan Motor	51-42534-25 (4)	51-42534-25 (6)	51-42534-25 (6)	51-42534-25 (6)
		Wiring Harness - Motor #1 & #4	45-42522-71	45-42522-71	45-42522-71	45-42522-71
		Wiring Harness - Motor #2 & #5	N/A	45-42522-70	45-42522-70	45-42522-70
		Wiring Harness - Motor #3 & #6	45-42522-69	45-42522-69	45-42522-69	45-42522-69
53	Stk	Fan Blade	70-42572-04 (4)	70-42572-04 (6)	70-42572-04 (6)	70-42572-04 (6)
60	Stk	Capacitor - Fan Motor	43-100496-12 (4)	43-100496-12 (6)	43-100496-12 (6)	43-100496-12 (6)

No.	Notes	MODEL TECHNICAL VARIATION COOLING CAPACITY ELECTRICAL DESIGNATION	RKNL- C 180/210 Y	RKNL- C 240 Y	RKNL- C 241 Y	RKNL- C 300 Y
FAN GROUP						
52	Stk	Fan Motor	51-42534-26 (4)	51-42534-26 (6)	51-42534-26 (6)	51-42534-26 (6)
		Wiring Harness - Motor #1 & #4	45-42522-71	45-42522-71	45-42522-71	45-42522-71
		Wiring Harness - Motor #2 & #5	N/A	45-42522-70	45-42522-70	45-42522-70
		Wiring Harness - Motor #3 & #6	45-42522-69	45-42522-69	45-42522-69	45-42522-69
53	Stk	Fan Blade	70-42572-04 (4)	70-42572-04 (6)	70-42572-04 (6)	70-42572-04 (6)
60	Stk	Capacitor - Fan Motor	43-100496-12 (4)	43-100496-12 (6)	43-100496-12 (6)	43-100496-12 (6)

No.	Notes	MODEL TECHNICAL VARIATION COOLING CAPACITY ELECTRICAL DESIGNATION DRIVE PACKAGE	RKNL- C 036-060 C L	RKNL- C 036-060 D L	RKNL- C 036-060 Y L	RKNL- C 036-060 C M	RKNL- C 036-060 D M	RKNL- C 036-060 Y M
BLOWER GROUP - BELT DRIVE								
62	Stk	Blower Assembly - Size 036 (Items 63-73, Excluding 67 and 72b)	AS-101336-01	AS-101336-01	AS-101336-01	AS-101336-05	AS-101336-05	AS-101336-05
62	Stk	Blower Assembly - Size 042 (Items 63-73, Excluding 67 and 72b)	AS-101336-01	AS-101336-01	N/A	AS-101336-01	AS-101336-01	N/A
62	Stk	Blower Assembly - Size 048 (Items 63-73, Excluding 67 and 72b)	AS-101336-05	AS-101336-05	AS-101336-05	AS-101336-04	AS-101336-04	AS-101336-04
62	Stk	Blower Assembly - Size 060 (Items 63-73, Excluding 67 and 72b)	AS-101336-05	AS-101336-05	AS-101336-05	AS-101336-05	AS-101336-05	AS-101336-05
63		Housing	AS-101341-01	AS-101341-01	AS-101341-01	AS-101341-01	AS-101341-01	AS-101341-01
64		Bearing Frame Tri-Arm (2)	70-41723-03	70-41723-03	70-41723-03	70-41723-03	70-41723-03	70-41723-03
65	Stk	Ball Bearing And Cushion (2)	70-41911-01	70-41911-01	70-41911-01	70-41911-01	70-41911-01	70-41911-01
66	Stk	Blower Shaft	70-21933-02	70-21933-02	70-21933-02	70-21933-02	70-21933-02	70-21933-02
67	Stk	Fixed Pitch Sheave - Size 036	71-21932-04	71-21932-04	71-100772-04	71-21932-03	71-21932-03	71-21932-03
67	Stk	Fixed Pitch Sheave - Size 042	71-21932-04	71-21932-04	N/A	71-21932-04	71-21932-04	N/A
67	Stk	Fixed Pitch Sheave - Size 048	71-21932-03	71-21932-03	71-21932-03	71-21932-02	71-21932-02	71-21932-02
67	Stk	Fixed Pitch Sheave - Size 060	71-21932-03	71-21932-03	71-21932-03	71-21932-03	71-21932-03	71-21932-03
68		Blower Support - Left	AE-58950-02	AE-58950-02	AE-58950-02	AE-58950-02	AE-58950-02	AE-58950-02
69	Stk	Blower Wheel	70-23589-01	70-23589-01	70-23589-01	70-23589-01	70-23589-01	70-23589-01
70		Cut-Off Tabulation	AE-64401-05	AE-64401-05	AE-64401-05	AE-64401-05	AE-64401-05	AE-64401-05

No.	Notes	MODEL TECHNICAL VARIATION COOLING CAPACITY ELECTRICAL DESIGNATION DRIVE PACKAGE	RKNL- C 036-060 C L	RKNL- C 036-060 D L	RKNL- C 036-060 Y L	RKNL- C 036-060 C M	RKNL- C 036-060 D M	RKNL- C 036-060 Y M
BLOWER MOTOR MOUNTING - BELT DRIVE								
MOTOR MOUNTING:								
71		Blower Bracket	AE-101124-01	AE-101124-01	AE-101124-01	AE-101124-01	AE-101124-01	AE-101124-01
72		Blower Bracket - Drive Side	AE-101124-04	AE-101124-04	AE-101124-04	AE-101124-04	AE-101124-04	AE-101124-04
72a		Grommet	56-18518-04	56-18518-04	56-18518-04	56-18518-04	56-18518-04	56-18518-04
72b		Cross Brace	AE-101467-01	AE-101467-01	AE-101467-01	AE-101467-01	AE-101467-01	AE-101467-01
73		Motor Mount Assembly	AS-101340-01	AS-101340-01	AS-101340-01	AS-101340-01	AS-101340-01	AS-101340-01

No.	Notes	MODEL TECHNICAL VARIATION COOLING CAPACITY ELECTRICAL DESIGNATION DRIVE PACKAGE	RKNL- C 036-060 C L	RKNL- C 036-060 D L	RKNL- C 036-060 Y L	RKNL- C 036-060 C M	RKNL- C 036-060 D M	RKNL- C 036-060 Y M
BLOWER MOTOR GROUP - BELT DRIVE								
74		Blower Motor - Size 036	51-42579-01	51-42579-01	51-22241-02	51-42579-01	51-42579-01	51-22241-02
74		Blower Motor - Size 042	51-42579-01	51-42579-01	N/A	51-42579-01	51-42579-01	N/A
74		Blower Motor - Size 048	51-42579-01	51-42579-01	51-22241-02	51-21909-01	51-21909-01	51-22241-02
74		Blower Motor - Size 060	51-21909-01	51-21909-01	51-22241-02	51-41936-01	51-41936-01	51-22241-01
75		Variable Pitch Sheave - Size 036	71-40427-30	71-40427-30	71-40427-30	71-40427-25	71-40427-25	71-40427-25
75		Variable Pitch Sheave - Size 042	71-40427-29	71-40427-29	N/A	71-40427-43	71-40427-43	N/A
75		Variable Pitch Sheave - Size 048	71-40427-29	71-40427-29	71-40427-29	71-40427-25	71-40427-25	71-40427-25
75		Variable Pitch Sheave - Size 060	71-40427-29	71-40427-29	71-40427-29	71-40427-43	71-40427-43	71-40427-43
76		Belt - Size 036	71-40235-43	71-40235-43	71-40235-43	71-40235-43	71-40235-43	71-40235-43
76		Belt - Size 042	71-40235-43	71-40235-43	N/A	71-40235-44	71-40235-44	N/A
76		Belt - Size 048	71-40235-42	71-40235-42	71-40235-42	71-40235-42	71-40235-42	71-40235-42
76		Belt - Size 060	71-40235-42	71-40235-42	71-40235-42	71-40235-44	71-40235-44	71-40235-44

No.	Notes	MODEL TECHNICAL VARIATION COOLING CAPACITY DRIVE PACKAGE	RKNL- C 072 L	RKNL- C 073 L	RKNL- C 085 L	RKNL- C 090 L
BLOWER ASSEMBLY GROUP - BELT DRIVE						
64	Stk	Blower Assembly (Includes Items 65-68)	AS-102711-02	AS-102711-02	AS-90757-01	AS-90757-01
65	Stk	Blower Wheel	70-21773-01	70-21773-01	70-42540-02	70-42540-02
66		Bearing Frame Tri-Arm (2)	70-41723-02	70-41723-02	70-42540-05	70-42540-05
67		Bearing with Bearing Lock (2)	70-41911-01	70-41911-01	70-41854-02	70-41854-02
68	Stk	Blower Shaft	70-21933-02	70-21933-02	70-42540-04	70-42540-04
69		Blower Mounting Angles (2)	AE-90708-01	AE-90708-01	AE-90708-01	AE-90708-01
		Blower Angle Stop	AE-90709-02	AE-90709-02	AE-90709-02	AE-90709-02
70		Motor Mount	AE-90710-05	AE-90710-05	AS-90824-01	AS-90824-01
71	Stk	Blower Motor - C/D Voltages	51-41936-03	51-41936-03	51-42536-01	51-42536-01
71	Stk	Blower Motor - Y Voltage	51-41936-04	51-41936-04	51-42536-02	51-42536-02
72	Stk	Variable Sheave	71-40427-29	71-40427-29	71-42538-02	71-42538-02
73	Stk	Belt	71-40235-46	71-40235-46	71-40438-30	71-40438-30
74	Stk	Fixed Sheave	71-100772-03	71-100772-03	71-100774-05	71-100774-05
		Key	94-22030-01	94-22030-01	94-42551-09	94-42551-09
	Stk	Bushing for Sheave w/Screws	N/A	N/A	71-100773-01	71-100773-01

No.	Notes	MODEL TECHNICAL VARIATION COOLING CAPACITY DRIVE PACKAGE	RKNL- C 102 L	RKNL- C 120 L	RKNL- C 150 L	RKNL- C 151 L
BLOWER ASSEMBLY GROUP - BELT DRIVE						
64	Stk	Blower Assembly (Includes Items 65-68)	AS-90757-01	AS-90757-01	AS-90757-01	AS-90757-01
65	Stk	Blower Wheel	70-42540-02	70-42540-02	70-42540-02	70-42540-02
66		Bearing Frame Tri-Arm (2)	70-42540-05	70-42540-05	70-42540-05	70-42540-05
67		Bearing with Bearing Lock (2)	70-41854-02	70-41854-02	70-41854-02	70-41854-02
68	Stk	Blower Shaft	70-42540-04	70-42540-04	70-42540-04	70-42540-04
69		Blower Mounting Angles (2)	AE-90708-01	AE-90708-01	AE-90708-01	AE-90708-01
		Blower Angle Stop	AE-90709-02	AE-90709-02	AE-90709-02	AE-90709-02
70		Motor Mount	AS-90824-01	AS-90824-01	AS-90824-01	AS-90824-01
71	Stk	Blower Motor - C/D Voltages	51-42536-01	51-42536-01	51-42537-01	51-42537-01
71	Stk	Blower Motor - Y Voltage	51-42536-02	51-42536-02	51-42537-02	51-42537-02
72	Stk	Variable Sheave	71-42538-02	71-42538-02	71-42538-02	71-42538-02
73	Stk	Belt	71-40438-27	71-40438-27	71-40438-23	71-40438-23
74	Stk	Fixed Sheave	71-100774-02	71-100774-02	71-100774-01	71-100774-01
		Key	94-42551-09	94-42551-09	94-42551-09	94-42551-09
	Stk	Bushing for Sheave w/Screws	71-100773-01	71-100773-01	71-100773-01	71-100773-01

No.	Notes	MODEL TECHNICAL VARIATION COOLING CAPACITY DRIVE PACKAGE	RKNL- C 072 M	RKNL- C 073 M	RKNL- C 085 M	RKNL- C 090 M
BLOWER ASSEMBLY GROUP - BELT DRIVE						
64	Stk	Blower Assembly (Includes Items 65-68)	AS-102711-02	AS-102711-02	AS-90757-01	AS-90757-01
65	Stk	Blower Wheel	70-21773-01	70-21773-01	70-42540-02	70-42540-02
66		Bearing Frame Tri-Arm (2)	70-41723-02	70-41723-02	70-42540-05	70-42540-05
67		Bearing with Bearing Lock (2)	70-41911-01	70-41911-01	70-41854-02	70-41854-02
68	Stk	Blower Shaft	70-21933-02	70-21933-02	70-42540-04	70-42540-04
69		Blower Mounting Angles (2)	AE-90708-01	AE-90708-01	AE-90708-01	AE-90708-01
		Blower Angle Stop	AE-90709-02	AE-90709-02	AE-90709-02	AE-90709-02
70		Motor Mount	AE-90710-05	AE-90710-05	AE-90710-04	AE-90710-04
71	Stk	Blower Motor - C/D Voltages	51-41936-03	51-41936-03	51-42536-01	51-42536-01
71	Stk	Blower Motor - Y Voltage	51-41936-04	51-41936-04	51-42536-02	51-42536-02
72	Stk	Variable Sheave	71-40427-25	71-40427-25	71-42538-02	71-42538-02
73	Stk	Belt	71-40235-48	71-40235-48	71-40438-27	71-40438-27
74	Stk	Fixed Sheave	71-100772-03	71-100772-03	71-100774-02	71-100774-02
		Key	94-22030-01	94-22030-01	94-42551-09	94-42551-09
	Stk	Bushing for Sheave w/Screws	N/A	N/A	71-100773-01	71-100773-01

No.	Notes	MODEL TECHNICAL VARIATION COOLING CAPACITY DRIVE PACKAGE	RKNL- C 102 M	RKNL- C 120 M	RKNL- C 150 M	RKNL- C 151 M
BLOWER ASSEMBLY GROUP - BELT DRIVE						
64	Stk	Blower Assembly (Includes Items 65-68)	AS-90757-01	AS-90757-01	AS-90757-01	AS-90757-01
65	Stk	Blower Wheel	70-42540-02	70-42540-02	70-42540-02	70-42540-02
66		Bearing Frame Tri-Arm (2)	70-42540-05	70-42540-05	70-42540-05	70-42540-05
67		Bearing with Bearing Lock (2)	70-41854-02	70-41854-02	70-41854-02	70-41854-02
68	Stk	Blower Shaft	70-42540-04	70-42540-04	70-42540-04	70-42540-04
69		Blower Mounting Angles (2)	AE-90708-01	AE-90708-01	AE-90708-01	AE-90708-01
		Blower Angle Stop	AE-90709-02	AE-90709-02	AE-90709-02	AE-90709-02
70		Motor Mount	AE-90710-04	AE-90710-04	AE-90710-04	AE-90710-04
71	Stk	Blower Motor - C/D Voltages	51-42537-01	51-42537-01	51-42498-07	51-102826-06
71	Stk	Blower Motor - Y Voltage	51-42537-02	51-42537-02	51-42574-01	51-102826-08
72	Stk	Variable Sheave	71-42538-02	71-42538-02	71-40427-11	71-40427-11
73	Stk	Belt	71-40438-23	71-40438-23	71-40438-31	71-40438-31
74	Stk	Fixed Sheave	71-100774-04	71-100774-04	71-26254-06	71-26254-06
		Key	94-42551-09	94-42551-09	94-42551-09	94-42551-09
	Stk	Bushing for Sheave w/Screws	71-100773-01	71-100773-01	71-100773-01	71-100773-01

No.	Notes	MODEL TECHNICAL VARIATION COOLING CAPACITY DRIVE PACKAGE	RKNL-	RKNL-	RKNL-	RKNL-	RKNL-
			C 180 L	C 210 L	C 240 L	C 241 L	C 300 L
BLOWER ASSEMBLY GROUP - BELT DRIVE							
64	Stk	Blower Assembly - Includes Items 65 and 66 (2)	AS-90757-06	AS-90757-06	AS-90757-06	AS-90757-06	AS-90757-06
65	Stk	Blower Wheel (2)	70-42564-02	70-42564-02	70-42564-02	70-42564-02	70-42564-02
66		Bearing Frame Tri-Arm (4)	70-42284-04	70-42284-04	70-42284-04	70-42284-04	70-42284-04
67		Bearing with Bearing Lock (4)	70-41854-02	70-41854-02	70-41854-02	70-41854-02	70-41854-02
68	Stk	Blower Shaft	70-42564-03	70-42564-03	70-42564-03	70-42564-03	70-42564-03
69		Blower Connector Angles (3)	AE-90798-01	AE-90798-01	AE-90798-01	AE-90798-01	AE-90798-01
70		Motor Mount	AE-90710-03	AE-90710-03	AE-90710-03	AE-90710-03	AE-90710-03
71	Stk	Blower Motor - C/D Voltages	51-42537-01	51-42537-01	51-102826-01	51-102826-06	51-102826-02
71	Stk	Blower Motor - Y Voltage	51-42537-02	51-42537-02	51-42574-01	51-102826-08	51-102826-04
72	Stk	Variable Sheave	71-42538-02	71-42538-02	71-40427-04	71-104625-11	71-40427-59
73	Stk	Belt	71-40438-43	71-40438-42	71-40438-51	71-40438-50	71-40438-54
74a	Stk	Fixed Sheave	71-100774-08	71-100774-09	71-100774-06	71-104627-16	71-100774-06
74b		Key	94-42551-09	94-42551-09	94-42551-09	94-42551-09	94-42551-09
74c	Stk	Bushing for Sheave w/Screws	71-100773-01	71-100773-01	71-100773-01	71-104629-02	71-100773-01

No.	Notes	MODEL TECHNICAL VARIATION COOLING CAPACITY DRIVE PACKAGE	RKNL-	RKNL-	RKNL-	RKNL-	RKNL-
			C 180 M	C 210 M	C 240 M	C 241 M	C 300 M
BLOWER ASSEMBLY GROUP - BELT DRIVE							
64	Stk	Blower Assembly - Includes Items 65 and 66 (2)	AS-90757-06	AS-90757-06	AS-90757-06	AS-90757-06	AS-90757-06
65	Stk	Blower Wheel (2)	70-42564-02	70-42564-02	70-42564-02	70-42564-02	70-42564-02
66		Bearing Frame Tri-Arm (4)	70-42284-04	70-42284-04	70-42284-04	70-42284-04	70-42284-04
67		Bearing with Bearing Lock (4)	70-41854-02	70-41854-02	70-41854-02	70-41854-02	70-41854-02
68	Stk	Blower Shaft	70-42564-03	70-42564-03	70-42564-03	70-42564-03	70-42564-03
69		Blower Connector Angles (3)	AE-90798-01	AE-90798-01	AE-90798-01	AE-90798-01	AE-90798-01
70		Motor Mount	AE-90710-03	AE-90710-03	AE-90710-03	AE-90710-03	AE-90710-03
71	Stk	Blower Motor - C/D Voltages	51-102826-01	51-102826-01	51-102826-02	51-102826-07	51-102826-03
71	Stk	Blower Motor - Y Voltage	51-42574-01	51-42574-01	51-102826-04	51-102826-09	51-102826-05
72	Stk	Variable Sheave	71-40427-04	71-40427-04	71-40427-59	71-104625-14	71-40427-60
73	Stk	Belt	71-40438-46	71-40438-46	71-40438-54	71-40438-54	71-102847-01
74a	Stk	Fixed Sheave	71-100774-08	71-100774-08	71-100774-06	71-104627-17	71-100774-07
74b		Key	94-42551-09	94-42551-09	94-42551-09	94-42551-09	94-42551-09
74c	Stk	Bushing for Sheave w/Screws	71-100773-01	71-100773-01	71-100773-01	71-104629-02	71-100773-01

No.	Notes	MODEL TECHNICAL VARIATION COOLING CAPACITY	RKNL- C 036	RKNL- C 042	RKNL- C 048	RKNL- C 060
COIL GROUP						
6		Filter Keeper	AE-59168-01	AE-59168-01	AE-59168-01	AE-59168-01
EVAPORATOR COIL:						
77	Stk	Evaporator Coil (Before F4613)	AS-102260-03	AS-102351-03	AS-102352-03	AS-102353-03
77	Stk	Evaporator Coil (On or After F4613)	AS-102260-13	AS-102351-13	AS-102352-13	AS-102353-13
Important Note: Different manufacturers of TXV were used on this unit, and the exact part number must be used when making repair. To obtain the correct part number of the TXV either: (1) Provide the part number of TXV assembly by examining unit, or (2) Provide unit model number and TXV manufacturer. (See attached TXV identification guide for assistance.)						
	Stk	TXV - Sporlan	61-102257-01	61-102257-02	61-102257-03	61-102257-04
	Stk	TXV - Emerson	61-102258-01	61-102258-02	61-102258-03	61-102258-04
80		Top Air Stop	AE-58933-01	AE-58933-01	AE-58933-01	AE-58933-01
81		Top Coil Support	AE-58941-01	AE-58941-01	AE-58941-01	AE-58941-01
82		Filter Channels (3) Center Is Two Channels Back To Back	AE-58934-01	AE-58934-01	AE-58934-01	AE-58934-01
83		Indoor Coil Drain Pan	68-23559-01	68-23559-01	68-23559-01	68-23559-01
CONDENSER COIL:						
84	Stk	Condenser Coil	AS-101714-03	AS-101715-01	AS-101716-01	AS-101717-01
	Stk	Filter Drier	83-22755-03	83-22755-03	83-22755-03	83-22755-03
85		Filter - Disposable (2)	54-17531-10	54-17531-10	54-17531-10	54-17531-10

No.	Notes	MODEL TECHNICAL VARIATION COOLING CAPACITY	RKNL- C 072	RKNL- C 073	RKNL- C 085	RKNL- C 090
COIL GROUP						
EVAPORATOR COIL GROUP:						
42	Stk	Evaporator Coil	AS-90656-70	AS-90656-88	AS-90656-76	AS-90656-68
	Stk	Distributor / Flowcheck Piston Assembly	61-102809-94	N/A	61-102912-98	N/A
	Stk	Flowcheck Piston Kit	61-25414-94	N/A	N/A	N/A
	Stk	Flowcheck Distributor	61-26113-35	N/A	N/A	N/A
	Stk	TXV - Circuit #1 (Before Date Code Fxxxx indicated)	N/A	61-101351-13 (F0514)	N/A	61-101351-11 (F1114)
	Stk	TXV - Circuit #1 (On or After Date Code Fxxxx indicated)	N/A	61-42662-19 (F0514)	N/A	61-42662-20 (F1114)
	Stk	TXV - Circuit #2 (Before Date Code Fxxxx indicated)	N/A	N/A	N/A	61-101351-11 (F1114)
	Stk	TXV - Circuit #2 (On or After Date Code Fxxxx indicated)	N/A	N/A	N/A	61-42662-20 (F1114)
		Bulb Strap Kit - TXV (2)	N/A	N/A	N/A	64-101357-01
43	Stk	Drain Pan - Removable	68-102699-02	68-102699-02	68-102699-02	68-102699-02
FILTER PIECES:						
44		Filter Frame	AE-90606-11	AE-90606-11	AE-90606-11	AE-90606-11
45		Air Stop - Bottom	AE-102712-10	AE-102712-10	AE-102712-10	AE-102712-10
46		Air Stop - Side	AE-102712-06	AE-102712-06	AE-102712-06	AE-102712-06
47		Top Air Stop Assembly	AS-90604-06	AS-90604-06	AS-90604-06	AS-90604-06
48		Filter Channel (2)	AE-102712-08	AE-102712-08	AE-102712-08	AE-102712-08
49		Filter Slide (2)	AE-102712-11	AE-102712-11	AE-102712-11	AE-102712-11
		Filter (6)	54-42541-01	54-42541-01	54-42541-01	54-42541-01
CONDENSER COIL GROUP:						
37a	Stk	Condenser Coil	AS-102704-03	AS-102704-03	AS-102704-03	AS-102704-03
37b	Stk	Condenser Coil	N/A	N/A	AS-102839-03	AS-102704-03
38		Front Air Stop	AE-90706-19	AE-90706-19	AE-90706-19	AE-90706-19
39		Rear Air Stop	AE-90706-18	AE-90706-18	AE-90706-18	AE-90706-18
40a,b		Bottom Retainer (2)	N/A	N/A	N/A	AE-90700-03
40a		Micro-Channel Coil Mounting Base - Left	N/A	N/A	N/A	N/A
40b		Micro-Channel Coil Mounting Base - Right	N/A	N/A	N/A	N/A
41a		Top Support - Condenser Coil	N/A	N/A	AE-90612-09	AE-90612-09
41b		Top Support - Condenser Bulkhead	N/A	N/A	AE-90612-19	AE-90612-03
	Stk	Filter Drier - Liquid Line	83-22755-05 (1)	83-22755-10 (1)	83-40386-05 (1)	83-22755-05 (2)
		Strap - Filter Drier	N/A	N/A	N/A	AE-102132-01 (2)
		Low Ambient Assembly - Option AR	AS-103034-01	N/A	AS-103034-01	AS-103034-01
	Stk	High Pressure Control	47-23699-04 (1)	47-23699-04 (1)	47-23699-04 (1)	47-23699-04 (1)
	Stk,3	Low Pressure Control - See Note 3	47-101529-09 (1)	47-101529-09 (1)	47-101529-09 (1)	47-101529-09 (2)

No.	Notes	MODEL TECHNICAL VARIATION COOLING CAPACITY	RKNL- C 102	RKNL- C 120	RKNL- C 150	RKNL- C 151
COIL GROUP						
EVAPORATOR COIL GROUP:						
42	Stk	Evaporator Coil	AS-90656-77	AS-90656-69	AS-90656-75	AS-90656-75
	Stk	TXV - Circuit #1 (Before Date Code Fxxxx indicated)	61-101351-12 (F1514)	61-101351-13 (F0514)	61-101351-14	61-101351-14
	Stk	TXV - Circuit #1 (On or After Date Code Fxxxx indicated)	61-42662-18 (F1514)	61-42662-19 (F0514)	61-101351-14	61-101351-14
	Stk	TXV - Circuit #2 (Before Date Code Fxxxx indicated)	61-101351-12 (F1514)	61-101351-13 (F0514)	61-101351-14	61-101351-14
	Stk	TXV - Circuit #2 (On or After Date Code Fxxxx indicated)	61-42662-18 (F1514)	61-42662-19 (F0514)	61-101351-14	61-101351-14
		Bulb Strap Kit - TXV (2)	64-101357-01	64-101357-01	64-101357-01	64-101357-01
43	Stk	Drain Pan - Removable	68-102699-02	68-102699-02	68-102699-02	68-102699-02
FILTER PIECES:						
44		Filter Frame	AE-90606-11	AE-90606-11	AE-90606-11	AE-90606-11
45		Air Stop - Bottom	AE-102712-10	AE-102712-10	AE-102712-10	AE-102712-10
46		Air Stop - Side	AE-102712-06	AE-102712-06	AE-102712-06	AE-102712-06
47		Top Air Stop Assembly	AS-90604-06	AS-90604-06	AS-90604-06	AS-90604-06
48		Filter Channel (2)	AE-102712-08	AE-102712-08	AE-102712-08	AE-102712-08
49		Filter Slide (2)	AE-102712-11	AE-102712-11	AE-102712-11	AE-102712-11
		Filter (6)	54-42541-01	54-42541-01	54-42541-01	54-42541-01
CONDENSER COIL GROUP:						
37a	Stk	Condenser Coil	AS-90656-25	AS-90656-42	65-101478-01	65-101478-08
37b	Stk	Condenser Coil	AS-90656-25	AS-90656-42	65-101478-01	65-101478-08
38		Front Air Stop	AE-90706-19	AE-90706-19	N/A	N/A
39		Rear Air Stop	AE-90706-18	AE-90706-18	N/A	N/A
40a, b		Bottom Retainer (2)	AE-90700-02	AE-90700-02	N/A	N/A
40a		Micro-Channel Coil Mounting Base - Left	N/A	N/A	68-102752-01	68-102752-01
40b		Micro-Channel Coil Mounting Base - Right	N/A	N/A	68-102752-02	68-102752-02
41a		Top Support - Condenser Coil	AE-90612-02	AE-90612-02	AE-90612-13	AE-90612-13
41b		Top Support - Condenser Bulkhead	AE-90612-03	AE-90612-03	AE-90612-05	AE-90612-05
	Stk	Filter Drier - Liquid Line	83-22755-05 (2)	83-22755-05 (2)	83-22755-05 (2)	83-22755-05 (2)
		Strap - Filter Drier	AE-102132-01 (2)	AE-102132-01 (2)	AE-102132-01 (2)	AE-102132-01 (2)
		Low Ambient Assembly - Option AR	N/A	N/A	N/A	N/A
	Stk	High Pressure Control	47-23699-04 (1)	47-23699-04 (1)	47-23699-04 (1)	47-23699-04 (1)
	Stk,3	Low Pressure Control - See Note 3	47-101529-09 (2)	47-101529-09 (2)	47-101529-09 (2)	47-101529-09 (2)

No.	Notes	MODEL	RKNL-	RKNL-	RKNL-	RKNL-	RKNL-
		TECHNICAL VARIATION	C	C	C	C	C
		COOLING CAPACITY	180	210	240	241	300
COIL GROUP (Granite/Steel Gray, After F4411)							
EVAPORATOR COIL GROUP:							
40		Air Flow Panel	AS-90828-02H	AS-90828-02H	AS-90828-02H	AE-90828-02HT	AS-90828-02H
42	Stk	Complete Coil - Indoor	AS-102821-03	AS-102821-03	AS-102652-03	AS-104258-03	AS-102428-03
	Stk	TXV/Distributor Assembly - Circuit #1	61-102845-01	61-102845-01	61-102687-01	61-102815-01	61-102815-01
	Stk	TXV/Distributor Assembly - Circuit #2	61-102845-01	61-102845-01	61-102687-01	61-102815-01	61-102815-01
43	Stk	Drain Pan - Removable	68-102699-01	68-102699-01	68-102699-01	68-102699-01	68-102699-01
FILTER PIECES:							
44		Filter Frame	AE-90606-10	AE-90606-10	AE-90606-10	AE-90606-10	AE-90606-10
45		Air Stop - Bottom (Before F1811)	AE-102712-05	AE-102712-05	AE-102712-05	N/A	AE-102712-05
45		Air Stop - Bottom (After F1811)	AE-102712-17	AE-102712-17	AE-102712-17	AE-102712-17	AE-102712-17
46		Air Stop - Side (Before F1811)	AE-102712-01	AE-102712-01	AE-102712-01	N/A	AE-102712-01
46		Air Stop - Side (After F1811)	AE-102712-14	AE-102712-14	AE-102712-14	AE-102712-14	AE-102712-14
47		Top Air Stop Assembly	AS-90604-04	AS-90604-04	AS-90604-04	AS-90604-04	AS-90604-04
48		Filter Channel (2) (Before F1811)	AE-102712-03	AE-102712-03	AE-102712-03	N/A	AE-102712-03
48		Filter Channel (2) (After F1811)	AE-102712-16	AE-102712-16	AE-102712-16	AE-102712-16	AE-102712-16
49		Filter Slide (2) (Before F1811)	AE-102712-02	AE-102712-02	AE-102712-02	N/A	AE-102712-02
49		Filter Slide (2) (After F1811)	AE-102712-15	AE-102712-15	AE-102712-15	AE-102712-15	AE-102712-15
50		Filter - 20 in. x 25 in. x 2 in. (8)	54-42541-04	54-42541-04	54-42541-04	54-42541-04	54-42541-04
CONDENSER COIL:							
37	Stk	Condenser Coil Assembly (2)	AS-102647-03	AS-103204-03	AS-102666-03	N/A	AS-102666-03
	Stk	Micro Channel Coil (2)	N/A	N/A	N/A	65-101478-09	N/A
38a		Air Stop - Front	AE-90706-13	AE-90706-13	AE-90706-13	AE-90706-25	AE-90706-13
38b		Corner Brace - Top Front	AS-90706-16H	AS-90706-16H	AS-90706-16H	AE-90706-16HT	AS-90706-16H
38c		Post - Outdoor Coil (Front)	AS-90706-14H	AS-90706-14H	AS-90706-14H	AE-90706-22HT	AS-90706-14H
39a		Air Stop - Rear	AE-90706-12	AE-90706-12	AE-90706-12	AE-90706-24	AE-90706-12
39b		Corner Brace - Top Rear	AS-90706-17H	AS-90706-17H	AS-90706-17H	AE-90706-17HT	AS-90706-17H
39c		Post - Outdoor Coil (Rear)	AS-90706-15H	AS-90706-15H	AS-90706-15H	AE-90706-23HT	AS-90706-15H
41		Air Stop- Top Right	AS-90753-08H	AS-90753-08H	AS-90753-08H	AE-90753-08HT	AS-90753-08H
41a		Top Support - Inner Condenser Coil (2)	AE-90612-21	AE-90612-08	AE-90612-08	AE-90612-28	AE-90612-08
41b		Top Support - Outer Condenser Coil	AE-90612-20	AE-90612-11	AE-90612-11	AE-90612-20	AE-90612-11
41c		Top Support - Condenser Bulkhead	AE-90612-18	AE-90612-06	AE-90612-06	AE-90612-27	AE-90612-06
		Filter Drier - Liquid Line (2)	83-22755-11	83-22755-11	83-22755-11	83-22755-19	83-22755-11
	Stk	High Pressure Control (2)	47-23699-04	47-23699-04	47-23699-04	47-23699-04	47-23699-04
	Stk,3	Low Pressure Control (2) - See Note 3	47-101529-09	47-101529-09	47-101529-09	47-101529-09	47-101529-09

No.	Notes	MODEL	RKNL- C 180	RKNL- C 210	RKNL- C 240	RKNL- C 300
		TECHNICAL VARIATION COOLING CAPACITY				
COIL GROUP (Neutra Green, Before F4411)						
EVAPORATOR COIL GROUP:						
40		Air Flow Panel	AS-90828-02A	AS-90828-02A	AS-90828-02A	AS-90828-02A
42	Stk	Complete Coil - Indoor	AS-102821-03	AS-102821-03	AS-102652-03	AS-102428-03
	Stk	TXV/Distributor Assembly - Circuit #1	61-102845-01	61-102845-01	61-102687-01	61-102815-01
	Stk	TXV/Distributor Assembly - Circuit #2	61-102845-01	61-102845-01	61-102687-01	61-102815-01
43	Stk	Drain Pan - Removable	68-102699-01	68-102699-01	68-102699-01	68-102699-01
FILTER PIECES:						
44		Filter Frame	AE-90606-10	AE-90606-10	AE-90606-10	AE-90606-10
45		Air Stop - Bottom (Before F1811)	AE-102712-05	AE-102712-05	AE-102712-05	AE-102712-05
45		Air Stop - Bottom (After F1811)	AE-102712-17	AE-102712-17	AE-102712-17	AE-102712-17
46		Air Stop - Side (Before F1811)	AE-102712-01	AE-102712-01	AE-102712-01	AE-102712-01
46		Air Stop - Side (After F1811)	AE-102712-14	AE-102712-14	AE-102712-14	AE-102712-14
47		Top Air Stop Assembly	AS-90604-04	AS-90604-04	AS-90604-04	AS-90604-04
48		Filter Channel (2) (Before F1811)	AE-102712-03	AE-102712-03	AE-102712-03	AE-102712-03
48		Filter Channel (2) (After F1811)	AE-102712-16	AE-102712-16	AE-102712-16	AE-102712-16
49		Filter Slide (2) (Before F1811)	AE-102712-02	AE-102712-02	AE-102712-02	AE-102712-02
49		Filter Slide (2) (After F1811)	AE-102712-15	AE-102712-15	AE-102712-15	AE-102712-15
50		Filter - 20 in. x 25 in. x 2 in. (8)	54-42541-04	54-42541-04	54-42541-04	54-42541-04
CONDENSER COIL:						
37	Stk	Condenser Coil Assembly (2)	AS-102647-03	AS-103204-03	AS-102666-03	AS-102666-03
38a		Air Stop - Front	AE-90706-13	AE-90706-13	AE-90706-13	AE-90706-13
38b		Corner Brace - Top Front	AS-90706-16A	AS-90706-16A	AS-90706-16A	AS-90706-16A
38c		Post - Outdoor Coil (Front)	AS-90706-14A	AS-90706-14A	AS-90706-14A	AS-90706-14A
39a		Air Stop - Rear	AE-90706-12	AE-90706-12	AE-90706-12	AE-90706-12
39b		Corner Brace - Top Rear	AS-90706-17A	AS-90706-17A	AS-90706-17A	AS-90706-17A
39c		Post - Outdoor Coil (Rear)	AS-90706-15A	AS-90706-15A	AS-90706-15A	AS-90706-15A
41		Air Stop- Top Right	AS-90753-08A	AS-90753-08A	AS-90753-08A	AS-90753-08A
41a		Top Support - Inner Condenser Coil (2)	AE-90612-21	AE-90612-08	AE-90612-08	AE-90612-08
41b		Top Support - Outer Condenser Coil	AE-90612-20	AE-90612-11	AE-90612-11	AE-90612-11
41c		Top Support - Condenser Bulkhead	AE-90612-18	AE-90612-06	AE-90612-06	AE-90612-06
		Filter Drier - Liquid Line (2)	83-22755-11	83-22755-11	83-22755-11	83-22755-11
	Stk	High Pressure Control (2)	47-23699-04	47-23699-04	47-23699-04	47-23699-04
	Stk,3	Low Pressure Control (2) - See Note 3	47-101529-09	47-101529-09	47-101529-09	47-101529-09

No.	Notes	MODEL	RKLN-	RKLN-	RKLN-	RKLN-
		TECHNICAL VARIATION	C	C	C	C
		COOLING CAPACITY	036	042	048	060
		ELECTRICAL DESIGNATION	C	C	C	C
COMPRESSOR GROUP						
		Compressor ID:	8204	8206	8208	8210
86	Stk	Compressor	55-102045-05S	55-102045-16S	55-102045-11S	55-102045-22S
40	Stk	Contactora	42-102664-08	42-102664-08	42-102664-08	42-102664-08
	Stk	Compressor Wiring Harness - Molded Plug	45-100834-10	45-100834-10	45-100834-10	45-100834-10

No.	Notes	MODEL	RKLN-	RKLN-	RKLN-	RKLN-
		TECHNICAL VARIATION	C	C	C	C
		COOLING CAPACITY	036	042	048	060
		ELECTRICAL DESIGNATION	D	D	D	D
COMPRESSOR GROUP						
		Compressor ID:	8205	8207	8209	8211
86	Stk	Compressor	55-102045-04S	55-102045-25S	55-102045-10S	55-102045-23S
40	Stk	Contactora	42-102664-08	42-102664-08	42-102664-08	42-102664-08
	Stk	Compressor Wiring Harness - Molded Plug	45-100834-10	45-100834-10	45-100834-10	45-100834-10

No.	Notes	MODEL	RKLN-	RKLN-	RKLN-	
		TECHNICAL VARIATION	C	C	C	
		COOLING CAPACITY	036	048	060	
		ELECTRICAL DESIGNATION	Y	Y	Y	
COMPRESSOR GROUP						
		Compressor ID:	8473	8474	8475	
86	Stk	Compressor	55-102045-32S	55-102045-29S	55-102045-30S	
40	Stk	Contactora	42-102664-08	42-102664-08	42-102664-08	
	Stk	Compressor Wiring Harness - Molded Plug	45-100834-10	45-100834-10	45-100834-10	

No.	Notes	MODEL	RKNL-	RKNL-	RKNL-	RKNL-
		TECHNICAL VARIATION				
		COOLING CAPACITY	072	073	085	090
		ELECTRICAL DESIGNATION	C	C	C	C
COMPRESSOR GROUP						
		Compressor ID:	7913	8592	7907	7867
75	Stk	Compressor #1	55-102045-37S	55-102471-21S	55-102045-43S	55-102045-08S
75	Stk	Compressor #2	N/A	N/A	N/A	55-102045-08S
	Stk	Crankcase Heater	44-17402-10	44-17402-10	44-17402-10	N/A
		Plug Harness - Compressor #1	45-102708-01	45-102708-01	45-102708-01	45-102708-01
		Plug Harness - Compressor #2	N/A	N/A	N/A	45-102708-02

No.	Notes	MODEL	RKNL-	RKNL-	RKNL-	RKNL-
		TECHNICAL VARIATION				
		COOLING CAPACITY	102	120	150	151
		ELECTRICAL DESIGNATION	C	C	C	C
COMPRESSOR GROUP						
		Compressor ID:	7937	7943	7870	8639
75	Stk	Compressor #1	55-102045-34S	55-102045-27S	55-102471-14S	55-102471-14S
75	Stk	Compressor #2	55-102045-34S	55-102045-27S	55-102471-18S	55-102471-18S
	Stk	Crankcase Heater	N/A	N/A	N/A	N/A
		Plug Harness - Compressor #1	45-102708-01	45-102708-01	45-102708-03	45-102708-03
		Plug Harness - Compressor #2	45-102708-02	45-102708-02	45-102708-04	45-102708-04
		Compressor ID:	8784			
75	Stk	Compressor #1	55-102045-93S			
75	Stk	Compressor #2	55-102045-93S			
	Stk	Crankcase Heater	N/A			
		Plug Harness - Compressor #1	45-102708-01			
		Plug Harness - Compressor #2	45-102708-02			

No.	Notes	MODEL	RKNL-	RKNL-	RKNL-	RKNL-
		TECHNICAL VARIATION				
		COOLING CAPACITY	072	073	085	090
		ELECTRICAL DESIGNATION	D	D	D	D
COMPRESSOR GROUP						
		Compressor ID:	7914	8593	7908	7868
75	Stk	Compressor #1	55-102045-38S	55-102471-22S	55-102045-45S	55-102045-07S
75	Stk	Compressor #2	N/A	N/A	N/A	55-102045-07S
	Stk	Crankcase Heater	44-17402-11	44-17402-11	44-17402-11	N/A
		Plug Harness - Compressor #1	45-102708-01	45-102708-01	45-102708-01	45-102708-01
		Plug Harness - Compressor #2	N/A	N/A	N/A	45-102708-02

No.	Notes	MODEL	RKNL-	RKNL-	RKNL-	RKNL-
		TECHNICAL VARIATION				
		COOLING CAPACITY	102	120	150	151
		ELECTRICAL DESIGNATION	D	D	D	D
COMPRESSOR GROUP						
		Compressor ID:	7938	7944	7871	8640
75	Stk	Compressor #1	55-102045-35S	55-102045-28S	55-102471-16S	55-102471-16S
75	Stk	Compressor #2	55-102045-35S	55-102045-28S	55-102471-19S	55-102471-19S
	Stk	Crankcase Heater	N/A	N/A	N/A	N/A
	Stk	Plug Harness - Compressor #1	45-102708-01	45-102708-01	45-102708-03	45-102708-03
	Stk	Plug Harness - Compressor #2	45-102708-02	45-102708-02	45-102708-04	45-102708-04
		Compressor ID:	8785			
75	Stk	Compressor #1	55-102045-94S			
75	Stk	Compressor #2	55-102045-94S			
	Stk	Crankcase Heater	N/A			
	Stk	Plug Harness - Compressor #1	45-102708-01			
	Stk	Plug Harness - Compressor #2	45-102708-02			

No.	Notes	MODEL TECHNICAL VARIATION COOLING CAPACITY ELECTRICAL DESIGNATION	RKNL- C 072 Y	RKNL- C 073 Y	RKNL- C 085 Y	RKNL- C 090 Y
COMPRESSOR GROUP						
		Compressor ID:	7915	8594	7909	7869
75	Stk	Compressor #1	55-102045-39S	55-102471-23S	55-102045-44S	55-102045-42S
75	Stk	Compressor #2	N/A	N/A	N/A	55-102045-42S
	Stk	Crankcase Heater	44-17402-12	44-17402-12	44-17402-12	N/A
		Plug Harness - Compressor #1	45-102708-01	45-102708-01	45-102708-01	45-102708-01
		Plug Harness - Compressor #2	N/A	N/A	N/A	45-102708-02

No.	Notes	MODEL TECHNICAL VARIATION COOLING CAPACITY ELECTRICAL DESIGNATION	RKNL- C 102 Y	RKNL- C 120 Y	RKNL- C 150 Y	RKNL- C 151 Y
COMPRESSOR GROUP						
		Compressor ID:	7939	7945	7872	8641
75	Stk	Compressor #1	55-102045-36S	55-102045-41S	55-102471-15S	55-102471-15S
75	Stk	Compressor #2	55-102045-36S	55-102045-41S	55-102471-17S	55-102471-17S
	Stk	Crankcase Heater	N/A	N/A	N/A	N/A
		Plug Harness - Compressor #1	45-102708-01	45-102708-01	45-102708-03	45-102708-03
		Plug Harness - Compressor #2	45-102708-02	45-102708-02	45-102708-04	45-102708-04
		Compressor ID:	8786			
75	Stk	Compressor #1	55-102045-95S			
75	Stk	Compressor #2	55-102045-95S			
	Stk	Crankcase Heater	N/A			
		Plug Harness - Compressor #1	45-102708-01			
		Plug Harness - Compressor #2	45-102708-02			

No.	Notes	MODEL TECHNICAL VARIATION COOLING CAPACITY ELECTRICAL DESIGNATION	RKLN- C 180 C	RKLN- C 210 C	RKLN- C 240 C	RKLN- C 241 C	RKLN- C 300 C
COMPRESSOR GROUP							
		Compressor:	7873	8050	7876	9520	7879
75	Stk	Compressor #1	55-23156-20S	55-102471-03S	55-102471-02S	55-102471-01S	55-102471-13S
75	Stk	Compressor #2	55-23156-20S	55-102471-03S	55-102471-03S	55-102471-24S	55-102471-13S
		Plug Harness - Compressor #1	45-42522-73	45-42522-73	45-42522-73	45-42522-73	45-42522-73
		Plug Harness - Compressor #2	45-42522-72	45-42522-72	45-42522-72	45-42522-72	45-42522-72
		High Pressure Control	See Coil Group				
		Low Pressure Control	See Coil Group				

No.	Notes	MODEL TECHNICAL VARIATION COOLING CAPACITY ELECTRICAL DESIGNATION	RKLN- C 180 D	RKLN- C 210 D	RKLN- C 240 D	RKLN- C 241 D	RKLN- C 300 D
COMPRESSOR GROUP							
		Compressor:	7874	8051	7877	9521	7880
75	Stk	Compressor #1	55-23156-21S	55-102471-07S	55-102471-09S	55-102471-04S	55-102471-08S
75	Stk	Compressor #2	55-23156-21S	55-102471-07S	55-102471-07S	55-102471-25S	55-102471-08S
		Plug Harness - Compressor #1	45-42522-73	45-42522-73	45-42522-73	45-42522-73	45-42522-73
		Plug Harness - Compressor #2	45-42522-72	45-42522-72	45-42522-72	45-42522-72	45-42522-72
		High Pressure Control	See Coil Group				
		Low Pressure Control	See Coil Group				

No.	Notes	MODEL TECHNICAL VARIATION COOLING CAPACITY ELECTRICAL DESIGNATION	RKLN- C 180 Y	RKLN- C 210 Y	RKLN- C 240 Y	RKLN- C 241 Y	RKLN- C 300 Y
COMPRESSOR GROUP							
		Compressor:	7875	8052	7878	9522	7881
75	Stk	Compressor #1	55-23156-22S	55-102471-10S	55-102471-10S	55-102471-05S	55-102471-12S
75	Stk	Compressor #2	55-23156-22S	55-102471-10S	55-102471-11S	55-102471-26S	55-102471-12S
		Plug Harness - Compressor #1	45-42522-73	45-42522-73	45-42522-73	45-42522-73	45-42522-73
		Plug Harness - Compressor #2	45-42522-72	45-42522-72	45-42522-72	45-42522-72	45-42522-72
		High Pressure Control	See Coil Group				
		Low Pressure Control	See Coil Group				

No.	Notes	MODEL TECHNICAL VARIATION HEATING CAPACITY	RKNL- C 08	RKNL- C 10	RKNL- C 12	RKNL- C 13
HEAT EXCHANGER, BURNER/MANIFOLD						
45	Stk	Main Limit - (Condenser Bulkhead) E - Electric	47-23610-19	47-23610-21	47-23610-27	47-23610-19
45	Stk	Main Limit - (Condenser Bulkhead) X - Nox	N/A	N/A	N/A	N/A
46		Main Limit Shield	AS-59152-01	AS-59152-01	AS-59152-01	AS-59152-01
87	Stk	Heat Exchanger - Includes Center Panel	AS-59066-01	AS-59066-05	AS-59066-04	AS-59066-04
88		Turbulators	AE-58922-01 (4)	AE-58922-01 (5)	AE-58922-01 (6)	AE-58922-01 (6)
89		NOX Inserts	N/A	N/A	N/A	N/A
90		Divider Plate Gasket	68-23680-02	68-23680-02	68-23680-02	68-23680-02
91		Divider Plate	AE-59067-01	AE-59067-01	AE-59067-01	AE-59067-01
92		Collector Box Gasket	68-23680-01	68-23680-01	68-23680-01	68-23680-01
93		Collector Box Cover	AE-59068-01	AE-59068-02	AE-59068-06	AE-59068-03
94		Flue Duct	75-23678-01	75-23678-01	75-23678-01	75-23678-01
95		Flue Duct Gasket	68-23680-03	68-23680-03	68-23680-03	68-23680-03
96		Burner Shield	AE-58886-01	AE-58886-01	AE-58886-01	AE-58886-01
97	Stk	Limit (Manual Reset)	47-22861-02 (1)	47-22861-02 (2)	47-22861-02 (2)	47-22861-02 (2)
98		Burner Compartment Floor	AE-58932-02	AE-58932-02	AE-58932-02	AE-58932-02
99	Stk	Burner Assembly	AS-60993-04	AS-60993-05	AS-60993-06	AS-60993-06
99a		Bushing	45-42519-01	45-42519-01	45-42519-01	45-42519-01
100		Burner Support - (Holds the Burners between the Burner Support Brackets)	AE-102650-01	AE-102650-01	AE-102650-01	AE-102650-01
101		Burner Support Bracket (2)	AE-61588-02	AE-61588-02	AE-61588-02	AE-61588-02
102	Stk	Manifold Assembly (w/o Orifices)	81-101153-01	81-101153-01	81-101153-01	81-101153-01
103		Square Head Plug - (Used on Manifold to plug extra holes)	81-23593-01 (3)	81-23593-01 (2)	81-23593-01 (1)	81-23593-01 (1)
104		Burner Orifice - Natural Gas:	See Orifice Selection Chart			
104		Burner Orifice - LP:	See Orifice Selection Chart			
104		Number of Orifices	(4)	(5)	(6)	(6)
105	Stk	Flame Sensor	62-23543-02	62-23543-02	62-23543-02	62-23543-02
106	Stk	Ignition Electrode and Cable	62-23556-01	62-23556-01	62-23556-01	62-23556-01

No.	Notes	MODEL TECHNICAL VARIATION COOLING CAPACITY ELECTRICAL DESIGNATION HEATING CAPACITY	RKNL- C 072/073 C,Y 15	RKNL- C 072/073 D 15	RKNL- C 085 C 15	RKNL- C 085 D 15	RKNL- C 085 C,Y 22	RKNL- C 085 D 22
HEAT EXCHANGER, BURNER / MANIFOLD								
98	Stk	Heat Exchanger	AS-90645-01	AS-90645-01	AS-90645-01	AS-90645-01	AS-90645-03	AS-90645-03
99		Inducer Mounting Plate Gasket	68-42518-02	68-42518-02	68-42518-02	68-42518-02	68-42518-02	68-42518-02
100		Turbulators	AE-58922-01 (6)	AE-58922-01 (6)	AE-58922-01 (6)	AE-58922-01 (6)	AE-58922-01 (9)	AE-58922-01 (9)
101		Inducer Mounting Plate	AE-90675-03	AE-90675-03	AE-90675-03	AE-90675-03	AE-90675-02	AE-90675-02
102		Inducer Blower Gasket - Before F1418	68-23643-02 (2)	68-23643-02 (2)	68-23643-02 (2)	68-23643-02 (2)	68-23643-02 (2)	68-23643-02 (2)
102		Inducer Blower Gasket - On or After F1418	68-23643-03 (2)	68-23643-03 (2)	68-23643-03 (2)	68-23643-03 (2)	68-23643-03 (2)	68-23643-03 (2)
103		Burner Support Brackets (2)	AE-90642-02	AE-90642-02	AE-90642-02	AE-90642-02	AE-90642-02	AE-90642-02
104		Burner Support	AE-90643-01	AE-90643-01	AE-90643-01	AE-90643-01	AE-90643-01	AE-90643-01
105	Stk	Spark Ignitor	62-23556-08	62-23556-08	62-23556-08	62-23556-08	62-23556-08	62-23556-08
106	Stk	Burner Assembly	AS-90772-01	AS-90772-01	AS-90772-01	AS-90772-01	AS-90772-02	AS-90772-02
107		Burner Orifices - Natural Gas	See Orifice Selection Chart					
107		Burner Orifices - LP	See Orifice Selection Chart					
107		Number of Orifices	(6)	(6)	(6)	(6)	(9)	(9)
108		Square Head Plug	81-23593-01 (4)	81-23593-01 (4)	81-23593-01 (4)	81-23593-01 (4)	81-23593-01 (1)	81-23593-01 (1)
109	Stk	Manifold	81-42509-03	81-42509-03	81-42509-03	81-42509-03	81-42509-02	81-42509-02
110		Gas Valve	See Gas Controls					
111		Street Elbow - 1/2 in. 90 degree	81-40271-04	81-40271-04	81-40271-04	81-40271-04	N/A	N/A
112	Stk	Flame Sensor	62-23543-02	62-23543-02	62-23543-02	62-23543-02	62-23543-02	62-23543-02
113a, b	Stk	Pressure Switch (2)	42-24335-25	42-24335-25	42-24335-25	42-24335-25	42-24335-23	42-24335-23
114		Pressure Switch Mounting Bracket (Single Mount)	AE-90635-05 (2)	AE-90635-05 (2)	AE-90635-05 (2)	AE-90635-05 (2)	AE-90635-05 (2)	AE-90635-05 (2)
115		Heat Shield	AE-90644-02	AE-90644-02	AE-90644-02	AE-90644-02	AE-90644-02	AE-90644-02
116	Stk	Limit - Manual Reset (Burner Compartment) (2)	47-22861-01	47-22861-01	47-22861-01	47-22861-01	47-22861-01	47-22861-01
117	Stk	Induced Draft Blower w/Gasket - Before F1418	70-23641-01 (2)	70-23641-02 (2)	70-23641-01 (2)	70-23641-02 (2)	70-23641-01 (2)	70-23641-02 (2)
117	Stk	Induced Draft Blower w/Gasket - On or After F1418	70-23641-06 (2)	70-23641-02 (2)	70-23641-06 (2)	70-23641-02 (2)	70-23641-06 (2)	70-23641-02 (2)
118		Flue Duct (2)	75-23678-01	75-23678-01	75-23678-01	75-23678-01	75-23678-01	75-23678-01
		Gasket - Flue Duct - Before F1418	68-23680-04 (4)	68-23680-04 (4)	68-23680-04 (4)	68-23680-04 (4)	68-23680-04 (4)	68-23680-04 (4)
		Gasket - Flue Duct - On or After F1418	68-23680-06 (2)	68-23680-06 (2)	68-23680-06 (2)	68-23680-06 (2)	68-23680-06 (2)	68-23680-06 (2)
	Stk	Limit - Main Limit (Heat Exchanger Panel)	47-25349-14	47-25349-14	47-25349-09	47-25349-09	47-25349-02	47-25349-02

No.	Notes	MODEL TECHNICAL VARIATION COOLING CAPACITY ELECTRICAL DESIGNATION HEATING CAPACITY	RKNL- C 090/102/120 C/Y 15	RKNL- C 090/102/120 D 15	RKNL- C 090/102/120 C/Y 22	RKNL- C 090/102/120 D 22
			HEAT EXCHANGER, BURNER / MANIFOLD			
98	Stk	Heat Exchanger	AS-90645-01	AS-90645-01	AS-90645-03	AS-90645-03
99		Inducer Mounting Plate Gasket	68-42518-02	68-42518-02	68-42518-02	68-42518-02
100		Turbulators	AE-58922-01 (6)	AE-58922-01 (6)	AE-58922-01 (9)	AE-58922-01 (9)
101		Inducer Mounting Plate	AE-90675-03	AE-90675-03	AE-90675-02	AE-90675-02
102		Inducer Blower Gasket - Before F1418	68-23643-02 (2)	68-23643-02 (2)	68-23643-02 (2)	68-23643-02 (2)
102		Inducer Blower Gasket - On or After F1418	68-23643-03 (2)	68-23643-03 (2)	68-23643-03 (2)	68-23643-03 (2)
103		Burner Support Brackets (2)	AE-90642-02	AE-90642-02	AE-90642-02	AE-90642-02
104		Burner Support	AE-90643-01	AE-90643-01	AE-90643-01	AE-90643-01
105	Stk	Spark Ignitor	62-23556-08	62-23556-08	62-23556-08	62-23556-08
106	Stk	Burner Assembly	AS-90772-01	AS-90772-01	AS-90772-02	AS-90772-02
107		Burner Orifices - Natural Gas	See Orifice Selection Chart			
107		Burner Orifices - LP	See Orifice Selection Chart			
107		Number of Orifices	(6)	(6)	(9)	(9)
108		Square Head Plug	81-23593-01 (4)	81-23593-01 (4)	81-23593-01 (1)	81-23593-01 (1)
109	Stk	Manifold	81-42509-03	81-42509-03	81-42509-02	81-42509-02
110		Gas Valve	See Gas Controls			
111		Street Elbow - 1/2 in. 90 degree	81-40271-04	81-40271-04	N/A	N/A
112	Stk	Flame Sensor	62-23543-02	62-23543-02	62-23543-02	62-23543-02
113a,b	Stk	Pressure Switch (2)	42-24335-25	42-24335-25	42-24335-23	42-24335-23
114		Pressure Switch Mounting Bracket (Single Mount)	AE-90635-05 (2)	AE-90635-05 (2)	AE-90635-05 (2)	AE-90635-05 (2)
115		Heat Shield	AE-90644-02	AE-90644-02	AE-90644-02	AE-90644-02
116	Stk	Limit - Manual Reset (Burner Compartment) (2)	47-22861-01	47-22861-01	47-22861-01	47-22861-01
117	Stk	Induced Draft Blower w/Gasket - Before F1418	70-23641-01 (2)	70-23641-02 (2)	70-23641-01 (2)	70-23641-02 (2)
117	Stk	Induced Draft Blower w/Gasket - On or After F1418	70-23641-06 (2)	70-23641-02 (2)	70-23641-06 (2)	70-23641-02 (2)
118		Flue Duct (2)	75-23678-01	75-23678-01	75-23678-01	75-23678-01
		Gasket - Flue Duct - Before F1418	68-23680-04 (4)	68-23680-04 (4)	68-23680-04 (4)	68-23680-04 (4)
		Gasket - Flue Duct - On or After F1418	68-23680-06 (2)	68-23680-06 (2)	68-23680-06 (2)	68-23680-06 (2)
	Stk	Limit - Main Limit (Heat Exchanger Panel)	47-25349-09	47-25349-09	47-25349-02	47-25349-02

No.	Notes	MODEL TECHNICAL VARIATION COOLING CAPACITY ELECTRICAL DESIGNATION HEATING CAPACITY	RKNL-	RKNL-	RKNL-	RKNL-
			C 150 C,Y 15	C 150 D 15	C 150 C,Y 25	C 150 D 25
HEAT EXCHANGER, BURNER / MANIFOLD						
98	Stk	Heat Exchanger	AS-90645-01	AS-90645-01	AS-90645-03	AS-90645-03
99		Inducer Mounting Plate Gasket	68-42518-02	68-42518-02	68-42518-02	68-42518-02
100		Turbulators	AE-58922-01 (6)	AE-58922-01 (6)	AE-58922-01 (9)	AE-58922-01 (9)
101		Inducer Mounting Plate	AE-90675-03	AE-90675-03	AE-90675-04	AE-90675-04
102		Inducer Blower Gasket - Before F1418	68-23643-02 (2)	68-23643-02 (2)	68-23643-02 (2)	68-23643-02 (2)
102		Inducer Blower Gasket - On or After F1418	68-23643-03 (2)	68-23643-03 (2)	68-23643-03 (2)	68-23643-03 (2)
103		Burner Support Brackets (2)	AE-90642-02	AE-90642-02	AE-90642-02	AE-90642-02
104		Burner Support	AE-90643-01	AE-90643-01	AE-90643-01	AE-90643-01
105	Stk	Spark Ignitor	62-23556-08	62-23556-08	62-23556-08	62-23556-08
106	Stk	Burner Assembly	AS-90772-01	AS-90772-01	AS-90772-02	AS-90772-02
107		Burner Orifices - Natural Gas	See Orifice Selection Chart			
107		Burner Orifices - LP	See Orifice Selection Chart			
107		Number of Orifices	(6)	(6)	(9)	(9)
108		Square Head Plug	81-23593-01 (4)	81-23593-01 (4)	81-23593-01 (1)	81-23593-01 (1)
109	Stk	Manifold	81-42509-03	81-42509-03	81-42509-02	81-42509-02
110		Gas Valve	See Gas Controls			
111		Street Elbow - 1/2 in. 90 degree	81-40271-04	81-40271-04	N/A	N/A
112	Stk	Flame Sensor	62-23543-02	62-23543-02	62-23543-02	62-23543-02
113a	Stk	Pressure Switch - Before F3311	42-24335-25	42-24335-25	42-24335-24 (See Note 4)	42-24335-24 (See Note 4)
113a	Stk	Pressure Switch - After F3311	42-24335-25	42-24335-25	42-24335-32	42-24335-32
113b	Stk	Pressure Switch	42-24335-25	42-24335-25	42-24335-23 (See Note 4)	42-24335-23 (See Note 4)
114		Pressure Switch Mounting Bracket (Single Mount)	AE-90635-05 (2)	AE-90635-05 (2)	AE-90635-05 (2)	AE-90635-05 (2)
115		Heat Shield	AE-90644-02	AE-90644-02	AE-90644-02	AE-90644-02
116	Stk	Limit - Manual Reset (Burner Compartment) (2)	47-22861-01	47-22861-01	47-22861-01	47-22861-01
117	Stk	Induced Draft Blower w/Gasket - Before F1418	70-23641-01 (2)	70-23641-02 (2)	70-23641-01 (2)	70-23641-02 (2)
117	Stk	Induced Draft Blower w/Gasket - On or After F1418	70-23641-06 (2)	70-23641-02 (2)	70-23641-06 (2)	70-23641-02 (2)
118		Flue Duct (2)	75-23678-01	75-23678-01	75-23678-01	75-23678-01
		Gasket - Flue Duct - Before F1418	68-23680-04 (4)	68-23680-04 (4)	68-23680-04 (4)	68-23680-04 (4)
		Gasket - Flue Duct - On or After F1418	68-23680-06 (2)	68-23680-06 (2)	68-23680-06 (2)	68-23680-06 (2)
	Stk	Limit - Main Limit (Heat Exchanger Panel)	47-25349-09	47-25349-09	47-25349-04	47-25349-04

No.	Notes	MODEL TECHNICAL VARIATION COOLING CAPACITY ELECTRICAL DESIGNATION HEATING CAPACITY	RKNL-	RKNL-	RKNL-	RKNL-
			C 151 C 15	C 151 D 15	C 151 C,Y 25	C 151 D 25
HEAT EXCHANGER, BURNER / MANIFOLD						
98	Stk	Heat Exchanger	AS-90645-01	AS-90645-01	AS-90645-03	AS-90645-03
99		Inducer Mounting Plate Gasket	68-42518-02	68-42518-02	68-42518-02	68-42518-02
100		Turbulators	AE-58922-01 (6)	AE-58922-01 (6)	AE-58922-01 (9)	AE-58922-01 (9)
101		Inducer Mounting Plate	AE-90675-03	AE-90675-03	AE-90675-04	AE-90675-04
102		Inducer Blower Gasket - Before F1418	68-23643-02 (2)	68-23643-02 (2)	68-23643-02 (2)	68-23643-02 (2)
102		Inducer Blower Gasket - On or After F1418	68-23643-03 (2)	68-23643-03 (2)	68-23643-03 (2)	68-23643-03 (2)
103		Burner Support Brackets (2)	AE-90642-02	AE-90642-02	AE-90642-02	AE-90642-02
104		Burner Support	AE-90643-01	AE-90643-01	AE-90643-01	AE-90643-01
105	Stk	Spark Ignitor	62-23556-08	62-23556-08	62-23556-08	62-23556-08
106	Stk	Burner Assembly	AS-90772-01	AS-90772-01	AS-90772-02	AS-90772-02
107		Burner Orifices - Natural Gas	See Orifice Selection Chart			
107		Burner Orifices - LP	See Orifice Selection Chart			
107		Number of Orifices	(6)	(6)	(9)	(9)
108		Square Head Plug	81-23593-01 (4)	81-23593-01 (4)	81-23593-01 (1)	81-23593-01 (1)
109	Stk	Manifold	81-42509-03	81-42509-03	81-42509-02	81-42509-02
110		Gas Valve	See Gas Controls			
111		Street Elbow - 1/2 in. 90 degree	81-40271-04	81-40271-04	N/A	N/A
112	Stk	Flame Sensor	62-23543-02	62-23543-02	62-23543-02	62-23543-02
113a	Stk	Pressure Switch - Before F3311	42-24335-25	42-24335-25	42-24335-24 (See Note 4)	42-24335-24 (See Note 4)
113a	Stk	Pressure Switch - After F3311	42-24335-25	42-24335-25	42-24335-32	42-24335-32
113b	Stk	Pressure Switch	42-24335-25	42-24335-25	42-24335-23 (See Note 4)	42-24335-23 (See Note 4)
114		Pressure Switch Mounting Bracket (Single Mount)	AE-90635-05 (2)	AE-90635-05 (2)	AE-90635-05 (2)	AE-90635-05 (2)
115		Heat Shield	AE-90644-02	AE-90644-02	AE-90644-02	AE-90644-02
116	Stk	Limit - Manual Reset (Burner Compartment) (2)	47-22861-01	47-22861-01	47-22861-01	47-22861-01
117	Stk	Induced Draft Blower w/Gasket - Before F1418	70-23641-01 (2)	70-23641-02 (2)	70-23641-01 (2)	70-23641-02 (2)
117	Stk	Induced Draft Blower w/Gasket - On or After F1418	70-23641-06 (2)	70-23641-02 (2)	70-23641-06 (2)	70-23641-02 (2)
118		Flue Duct (2)	75-23678-01	75-23678-01	75-23678-01	75-23678-01
		Gasket - Flue Duct - Before F1418	68-23680-04 (4)	68-23680-04 (4)	68-23680-04 (4)	68-23680-04 (4)
		Gasket - Flue Duct - On or After F1418	68-23680-06 (2)	68-23680-06 (2)	68-23680-06 (2)	68-23680-06 (2)
	Stk	Limit - Main Limit (Heat Exchanger Panel)	47-25349-09	47-25349-09	47-25349-04	47-25349-04

No.	Notes	MODEL TECHNICAL VARIATION COOLING CAPACITY ELECTRICAL DESIGNATION HEATING CAPACITY	RKNL-	RKNL-	RKNL-	RKNL-
			C 180 C 25	C 180 D 25	C 180 C,Y 35	C 180 D 35
HEAT EXCHANGER, BURNER / MANIFOLD						
	Stk	Heat Exchanger	AS-90645-12	AS-90645-12	AS-90645-15	AS-90645-15
		Inducer Mounting Plate Gasket	68-42518-03	68-42518-03	68-42518-03	68-42518-03
		Turbulators	AE-58922-02 (10)	AE-58922-02 (10)	AE-58922-02 (14)	AE-58922-02 (14)
		Inducer Mounting Plate	AE-90675-08	AE-90675-08	AE-90675-06	AE-90675-06
		Inducer Blower Gasket - Before F1418	68-23643-02 (2)	68-23643-02 (2)	68-23643-02 (2)	68-23643-02 (2)
		Inducer Blower Gasket - On or After F1418	68-23643-03 (2)	68-23643-03 (2)	68-23643-03 (2)	68-23643-03 (2)
103		Burner Support Brackets (2)	AE-90642-02	AE-90642-02	AE-90642-02	AE-90642-02
104		Burner Support	AS-90830-01	AS-90830-01	AS-90830-01	AS-90830-01
105	Stk	Spark Ignitor	62-23556-10	62-23556-10	62-23556-10	62-23556-10
106	Stk	Burner Assembly	AS-90641-29	AS-90641-29	AS-90641-30	AS-90641-30
107		Burner Orifices - Natural Gas	See Orifice Selection Chart			
107		Burner Orifices - LP	See Orifice Selection Chart			
107		Number of Orifices	(10)	(10)	(14)	(14)
108		Square Head Plug	81-23593-01 (3)	81-23593-01 (3)	81-23593-01 (1)	81-23593-01 (1)
109	Stk	Manifold	81-42509-07	81-42509-07	81-42509-04	81-42509-04
110		Gas Valve	See Gas Controls			
111		Street Elbow - 3/4 in. 90 degree	81-40271-05	81-40271-05	81-40271-05	81-40271-05
		Nipple - 3/4 in. x 2-1/2 in.	81-40383-04	81-40383-04	81-40383-04	81-40383-04
		Standard Elbow - 3/4 in.	81-40394-05	81-40394-05	N/A	N/A
		Standard Elbow - 1 in. x 3/4 in. 90 degree	N/A	N/A	81-40394-24	81-40394-24
112	Stk	Flame Sensor	62-23543-02	62-23543-02	62-23543-02	62-23543-02
	Stk	Pressure Switch - High	42-24335-23 (1)	42-24335-23 (1)	42-24335-23 (1)	42-24335-23 (1)
	Stk	Pressure Switch - Low	42-24335-24 (1)	42-24335-24 (1)	42-24335-24 (2)	42-24335-24 (2)
		Pressure Switch Mounting Bracket (Single Mount)	AE-90635-05 (1)	AE-90635-05 (1)	AE-90635-05 (2)	AE-90635-05 (2)
		Pressure Switch Mounting Bracket (Dual Mount)	AE-90635-04	AE-90635-04	AE-90635-04	AE-90635-04
115		Heat Shield	AE-90644-03	AE-90644-03	AE-90644-03	AE-90644-03
116	Stk	Limit - Manual Reset (Burner Compartment) (4)	47-22861-01	47-22861-01	47-22861-01	47-22861-01
	Stk	Induced Draft Blower w/Gasket - Before F1418	70-23641-01 (2)	70-23641-02 (2)	70-23641-01 (2)	70-23641-02 (2)
	Stk	Induced Draft Blower w/Gasket - On or After F1418	70-23641-06 (2)	70-23641-02 (2)	70-23641-06 (2)	70-23641-02 (2)
		Flue Duct	75-23678-01 (2)	75-23678-01 (2)	75-23678-01 (3)	75-23678-01 (3)
		Gasket - Flue Duct - Before F1418	68-23680-04 (4)	68-23680-04 (4)	68-23680-04 (6)	68-23680-04 (6)
		Gasket - Flue Duct - On or After F1418	68-23680-06 (2)	68-23680-06 (2)	68-23680-06 (3)	68-23680-06 (3)
	Stk	Limit - Main Limit (Heat Exchanger Panel)	47-25349-09	47-25349-09	47-25349-03	47-25349-03

No.	Notes	MODEL TECHNICAL VARIATION COOLING CAPACITY ELECTRICAL DESIGNATION HEATING CAPACITY	RKNL-	RKNL-	RKNL-	RKNL-
			C 210 C 25	C 210 D 25	C 210 C,Y 35	C 210 D 35
HEAT EXCHANGER, BURNER / MANIFOLD						
	Stk	Heat Exchanger	AS-90645-12	AS-90645-12	AS-90645-15	AS-90645-15
		Inducer Mounting Plate Gasket	68-42518-03	68-42518-03	68-42518-03	68-42518-03
		Turbulators	AE-58922-02 (10)	AE-58922-02 (10)	AE-58922-02 (14)	AE-58922-02 (14)
		Inducer Mounting Plate	AE-90675-08	AE-90675-08	AE-90675-06	AE-90675-06
		Inducer Blower Gasket - Before F1418	68-23643-02 (2)	68-23643-02 (2)	68-23643-02 (3)	68-23643-02 (3)
		Inducer Blower Gasket - On or After F1418	68-23643-03 (2)	68-23643-03 (2)	68-23643-03 (3)	68-23643-03 (3)
103		Burner Support Brackets (2)	AE-90642-02	AE-90642-02	AE-90642-02	AE-90642-02
104		Burner Support	AS-90830-01	AS-90830-01	AS-90830-01	AS-90830-01
105	Stk	Spark Ignitor	62-23556-10	62-23556-10	62-23556-10	62-23556-10
106	Stk	Burner Assembly	AS-90641-29	AS-90641-29	AS-90641-30	AS-90641-30
107		Burner Orifices - Natural Gas	See Orifice Selection Chart			
107		Burner Orifices - LP	See Orifice Selection Chart			
107		Number of Orifices	(10)	(10)	(14)	(14)
108		Square Head Plug	81-23593-01 (3)	81-23593-01 (3)	81-23593-01 (1)	81-23593-01 (1)
109	Stk	Manifold	81-42509-07	81-42509-07	81-42509-04	81-42509-04
110		Gas Valve	See Gas Controls			
111		Street Elbow - 3/4 in. 90 degree	81-40271-05	81-40271-05	81-40271-05	81-40271-05
		Nipple - 3/4 in. x 2-1/2 in.	81-40383-04	81-40383-04	81-40383-04	81-40383-04
		Standard Elbow - 3/4 in.	81-40394-05	81-40394-05	N/A	N/A
		Standard Elbow - 1 in. x 3/4 in. 90 degree	N/A	N/A	81-40394-24	81-40394-24
112	Stk	Flame Sensor	62-23543-02	62-23543-02	62-23543-02	62-23543-02
	Stk	Pressure Switch - High	42-24335-23 (1)	42-24335-23 (1)	42-24335-23 (1)	42-24335-23 (1)
	Stk	Pressure Switch - Low	42-24335-24 (1)	42-24335-24 (1)	42-24335-24 (2)	42-24335-24 (2)
		Pressure Switch Mounting Bracket (Single Mount)	AE-90635-05 (1)	AE-90635-05 (1)	AE-90635-05 (2)	AE-90635-05 (2)
		Pressure Switch Mounting Bracket (Dual Mount)	AE-90635-04	AE-90635-04	AE-90635-04	AE-90635-04
115		Heat Shield	AE-90644-03	AE-90644-03	AE-90644-03	AE-90644-03
116	Stk	Limit - Manual Reset (Burner Compartment) (4)	47-22861-01	47-22861-01	47-22861-01	47-22861-01
	Stk	Induced Draft Blower w/Gasket - Before F1418	70-23641-01 (2)	70-23641-02 (2)	70-23641-01 (3)	70-23641-02 (3)
	Stk	Induced Draft Blower w/Gasket - On or After F1418	70-23641-06 (2)	70-23641-02 (2)	70-23641-06 (3)	70-23641-02 (3)
		Flue Duct	75-23678-01 (2)	75-23678-01 (2)	75-23678-01 (3)	75-23678-01 (3)
		Gasket - Flue Duct - Before F1418	68-23680-04 (4)	68-23680-04 (4)	68-23680-04 (6)	68-23680-04 (6)
		Gasket - Flue Duct - On or After F1418	68-23680-06 (2)	68-23680-06 (2)	68-23680-06 (3)	68-23680-06 (3)
	Stk	Limit - Main Limit (Heat Exchanger Panel)	47-25349-09	47-25349-09	47-25349-03	47-25349-03

No.	Notes	MODEL TECHNICAL VARIATION COOLING CAPACITY ELECTRICAL DESIGNATION HEATING CAPACITY	RKNL-	RKNL-	RKNL-	RKNL-
			C 240 C 30	C 240 D 30	C 240 C,Y 40	C 240 D 40
HEAT EXCHANGER, BURNER / MANIFOLD						
	Stk	Heat Exchanger	AS-90645-16	AS-90645-16	AS-90645-15	AS-90645-15
		Inducer Mounting Plate Gasket	68-42518-03	68-42518-03	68-42518-03	68-42518-03
		Turbulators	AE-58922-02 (12)	AE-58922-02 (12)	AE-58922-02 (14)	AE-58922-02 (14)
		Inducer Mounting Plate	AE-90675-07	AE-90675-07	AE-90675-05	AE-90675-05
		Inducer Blower Gasket - Before F1418	68-23643-02 (3)	68-23643-02 (3)	68-23643-02 (4)	68-23643-02 (4)
		Inducer Blower Gasket - On or After F1418	68-23643-03 (3)	68-23643-03 (3)	68-23643-03 (4)	68-23643-03 (4)
103		Burner Support Brackets (2)	AE-90642-02	AE-90642-02	AE-90642-02	AE-90642-02
104		Burner Support	AS-90830-01	AS-90830-01	AS-90830-01	AS-90830-01
105	Stk	Spark Ignitor	62-23556-10	62-23556-10	62-23556-10	62-23556-10
106	Stk	Burner Assembly	AS-90641-31	AS-90641-31	AS-90641-25	AS-90641-25
107		Burner Orifices - Natural Gas	See Orifice Selection Chart			
107		Burner Orifices - LP	See Orifice Selection Chart			
107		Number of Orifices	(12)	(12)	(14)	(14)
108		Square Head Plug	81-23593-01 (1)	81-23593-01 (1)	81-23593-01 (1)	81-23593-01 (1)
109	Stk	Manifold	81-42509-07	81-42509-07	81-42509-04	81-42509-04
110		Gas Valve	See Gas Controls			
111		Street Elbow - 3/4 in. 90 degree	81-40271-05	81-40271-05	81-40271-05	81-40271-05
		Nipple - 3/4 in. x 2-1/2 in.	81-40383-04	81-40383-04	81-40383-04	81-40383-04
		Standard Elbow - 3/4 in.	81-40394-05	81-40394-05	N/A	N/A
		Standard Elbow - 1 in. x 3/4 in. 90 degree	N/A	N/A	81-40394-24	81-40394-24
112	Stk	Flame Sensor	62-23543-02	62-23543-02	62-23543-02	62-23543-02
	Stk	Pressure Switch - High	42-24335-21 (1)	42-24335-21 (1)	42-24335-23 (2)	42-24335-23 (2)
	Stk	Pressure Switch - Low	42-24335-24 (2)	42-24335-24 (2)	42-24335-24 (2)	42-24335-24 (2)
		Pressure Switch Mounting Bracket (Single Mount)	AE-90635-05 (2)	AE-90635-05 (2)	AE-90635-05 (2)	AE-90635-05 (2)
		Pressure Switch Mounting Bracket (Dual Mount)	AE-90635-04	AE-90635-04	AE-90635-04	AE-90635-04
115		Heat Shield	AE-90644-03	AE-90644-03	AE-90644-03	AE-90644-03
116	Stk	Limit - Manual Reset (Burner Compartment) (4)	47-22861-01	47-22861-01	47-22861-01	47-22861-01
	Stk	Induced Draft Blower w/Gasket - Before F1418	70-23641-01 (3)	70-23641-02 (3)	70-23641-01 (4)	70-23641-02 (4)
	Stk	Induced Draft Blower w/Gasket - On or After F1418	70-23641-06 (3)	70-23641-02 (3)	70-23641-06 (4)	70-23641-02 (4)
		Flue Duct	75-23678-01 (3)	75-23678-01 (3)	75-23678-01 (4)	75-23678-01 (4)
		Gasket - Flue Duct - Before F1418	68-23680-04 (6)	68-23680-04 (6)	68-23680-04 (8)	68-23680-04 (8)
		Gasket - Flue Duct - On or After F1418	68-23680-06 (3)	68-23680-06 (3)	68-23680-06 (4)	68-23680-06 (4)
	Stk	Limit - Main Limit (Heat Exchanger Panel)	47-25349-14	47-25349-14	47-25349-14	47-25349-14

No.	Notes	MODEL TECHNICAL VARIATION COOLING CAPACITY ELECTRICAL DESIGNATION HEATING CAPACITY	RKNL- C 241 C 30	RKNL- C 241 D 30	RKNL- C 241 C,Y 40	RKNL- C 241 D 40
HEAT EXCHANGER, BURNER / MANIFOLD						
	Stk	Heat Exchanger	AS-90645-16	AS-90645-16	AS-90645-15	AS-90645-15
		Inducer Mounting Plate Gasket	68-42518-03	68-42518-03	68-42518-03	68-42518-03
		Turbulators	AE-58922-02 (12)	AE-58922-02 (12)	AE-58922-02 (14)	AE-58922-02 (14)
		Inducer Mounting Plate	AE-90675-07	AE-90675-07	AE-90675-05	AE-90675-05
		Inducer Blower Gasket	68-23643-03 (3)	68-23643-03 (3)	68-23643-03 (4)	68-23643-03 (4)
103		Burner Support Brackets (2)	AE-90642-02	AE-90642-02	AE-90642-02	AE-90642-02
104		Burner Support	AS-90830-01	AS-90830-01	AS-90830-01	AS-90830-01
105	Stk	Spark Ignitor	62-23556-10	62-23556-10	62-23556-10	62-23556-10
106	Stk	Burner Assembly	AS-90641-31	AS-90641-31	AS-90641-25	AS-90641-25
107		Burner Orifices - Natural Gas	See Orifice Selection Chart			
107		Burner Orifices - LP	See Orifice Selection Chart			
107		Number of Orifices	(12)	(12)	(14)	(14)
108		Square Head Plug	81-23593-01 (1)	81-23593-01 (1)	81-23593-01 (1)	81-23593-01 (1)
109	Stk	Manifold	81-42509-07	81-42509-07	81-42509-04	81-42509-04
110		Gas Valve	See Gas Controls			
111		Street Elbow - 3/4 in. 90 degree	81-40271-05	81-40271-05	81-40271-05	81-40271-05
		Nipple - 3/4 in. x 2-1/2 in.	81-40383-04	81-40383-04	81-40383-04	81-40383-04
		Standard Elbow - 3/4 in.	81-40394-05	81-40394-05	N/A	N/A
		Standard Elbow - 1 in. x 3/4 in. 90 degree	N/A	N/A	81-40394-24	81-40394-24
112	Stk	Flame Sensor	62-23543-02	62-23543-02	62-23543-02	62-23543-02
	Stk	Pressure Switch - High	42-105601-21 (1)	42-105601-21 (1)	42-105601-25 (2)	42-105601-25 (2)
	Stk	Pressure Switch - Low	42-105601-24 (2)	42-105601-24 (2)	42-105601-24 (2)	42-105601-24 (2)
		Pressure Switch Mounting Bracket (Single Mount)	AE-90635-05 (2)	AE-90635-05 (2)	AE-90635-05 (2)	AE-90635-05 (2)
		Pressure Switch Mounting Bracket (Dual Mount)	AE-90635-04	AE-90635-04	AE-90635-04	AE-90635-04
115		Heat Shield	AE-90644-03	AE-90644-03	AE-90644-03	AE-90644-03
116	Stk	Limit - Manual Reset (Burner Compartment) (4)	47-22861-01	47-22861-01	47-22861-01	47-22861-01
	Stk	Induced Draft Blower w/Gasket	70-23641-06 (3)	70-23641-02 (3)	70-23641-06 (4)	70-23641-02 (4)
		Flue Duct	75-23678-01 (3)	75-23678-01 (3)	75-23678-01 (4)	75-23678-01 (4)
		Gasket - Flue Duct	68-23680-06 (3)	68-23680-06 (3)	68-23680-06 (4)	68-23680-06 (4)
	Stk	Limit - Main Limit (Heat Exchanger Panel)	47-25349-14	47-25349-14	47-25349-14	47-25349-14

No.	Notes	MODEL TECHNICAL VARIATION COOLING CAPACITY ELECTRICAL DESIGNATION HEATING CAPACITY	RKNL-	RKNL-	RKNL-	RKNL-
			C 300 C 30	C 300 D 30	C 300 C,Y 40	C 300 D 40
HEAT EXCHANGER, BURNER / MANIFOLD						
	Stk	Heat Exchanger	AS-90645-16	AS-90645-16	AS-90645-15	AS-90645-15
		Inducer Mounting Plate Gasket	68-42518-03	68-42518-03	68-42518-03	68-42518-03
		Turbulators	AE-58922-02 (12)	AE-58922-02 (12)	AE-58922-02 (14)	AE-58922-02 (14)
		Inducer Mounting Plate	AE-90675-07	AE-90675-07	AE-90675-05	AE-90675-05
		Inducer Blower Gasket - Before F1418	68-23643-02 (3)	68-23643-02 (3)	68-23643-02 (4)	68-23643-02 (4)
		Inducer Blower Gasket - On or After F1418	68-23643-03 (3)	68-23643-03 (3)	68-23643-03 (4)	68-23643-03 (4)
103		Burner Support Brackets (2)	AE-90642-02	AE-90642-02	AE-90642-02	AE-90642-02
104		Burner Support	AS-90830-01	AS-90830-01	AS-90830-01	AS-90830-01
105	Stk	Spark Ignitor	62-23556-10	62-23556-10	62-23556-10	62-23556-10
106	Stk	Burner Assembly	AS-90641-31	AS-90641-31	AS-90641-25	AS-90641-25
107		Burner Orifices - Natural Gas	See Orifice Selection Chart			
107		Burner Orifices - LP	See Orifice Selection Chart			
107		Number of Orifices	(12)	(12)	(14)	(14)
108		Square Head Plug	81-23593-01 (1)	81-23593-01 (1)	81-23593-01 (1)	81-23593-01 (1)
109	Stk	Manifold	81-42509-07	81-42509-07	81-42509-04	81-42509-04
110		Gas Valve	See Gas Controls			
111		Street Elbow - 3/4 in. 90 degree	81-40271-05	81-40271-05	81-40271-05	81-40271-05
		Nipple - 3/4 in. x 2-1/2 in.	81-40383-04	81-40383-04	81-40383-04	81-40383-04
		Standard Elbow - 3/4 in.	81-40394-05	81-40394-05	N/A	N/A
		Standard Elbow - 1 in. x 3/4 in. 90 degree	N/A	N/A	81-40394-24	81-40394-24
112	Stk	Flame Sensor	62-23543-02	62-23543-02	62-23543-02	62-23543-02
	Stk	Pressure Switch - High	42-24335-21 (1)	42-24335-21 (1)	42-24335-23 (2)	42-24335-23 (2)
	Stk	Pressure Switch - Low	42-24335-24 (2)	42-24335-24 (2)	42-24335-24 (2)	42-24335-24 (2)
		Pressure Switch Mounting Bracket (Single Mount)	AE-90635-05 (2)	AE-90635-05 (2)	AE-90635-05 (2)	AE-90635-05 (2)
		Pressure Switch Mounting Bracket (Dual Mount)	AE-90635-04	AE-90635-04	AE-90635-04	AE-90635-04
115		Heat Shield	AE-90644-03	AE-90644-03	AE-90644-03	AE-90644-03
116	Stk	Limit - Manual Reset (Burner Compartment) (4)	47-22861-01	47-22861-01	47-22861-01	47-22861-01
	Stk	Induced Draft Blower w/Gasket - Before F1418	70-23641-01 (3)	70-23641-02 (3)	70-23641-01 (4)	70-23641-02 (4)
	Stk	Induced Draft Blower w/Gasket - On or After F1418	70-23641-06 (3)	70-23641-02 (3)	70-23641-06 (4)	70-23641-02 (4)
		Flue Duct	75-23678-01 (3)	75-23678-01 (3)	75-23678-01 (4)	75-23678-01 (4)
		Gasket - Flue Duct - Before F1418	68-23680-04 (6)	68-23680-04 (6)	68-23680-04 (8)	68-23680-04 (8)
		Gasket - Flue Duct - On or After F1418	68-23680-06 (3)	68-23680-06 (3)	68-23680-06 (4)	68-23680-06 (4)
	Stk	Limit - Main Limit (Heat Exchanger Panel)	47-25349-09	47-25349-09	47-25349-03	47-25349-03

No.	Notes	MODEL GAS CODE COOLING CAPACITY	RKNL- 2S 036-060	RKNL- 2R 036-060
GAS CONTROLS				
	Stk	Gas Valve - Natural Gas	60-105055-01	60-23490-01
	Stk	Gas Valve - LP	See Note 2	See Note 2
	Stk	Integrated Furnace Control Board (IFC)	62-102860-02	62-102860-02
		Street Elbow	81-17487-01	81-40271-04
		Nipple	81-40683-02	N/A
	Stk	LP Conversion Kit	EP-85H	EP-84W

No.	Notes	MODEL GAS CODE COOLING CAPACITY	RKNL- 2P 072-300	RKNL- 2Q 072-300
GAS CONTROLS				
	Stk	Gas Valve - Natural Gas	60-101778-01	60-102405-01
	Stk	Gas Valve - LP	See Note 2	See Note 1
	Stk,5	Integrated Furnace Control Board (IFC) - See Note 5	62-102860-02	62-102860-02
		Street Elbow	See Heat Exchanger Group	
	Stk	LP Conversion Kit	FP-14	FP-24

No.	Notes	MODEL GAS CODE COOLING CAPACITY	RKNL- 2V 036-060	RKNL- 2Y 036-060
GAS CONTROLS				
	Stk	Gas Valve - Natural Gas	60-105055-01	60-106207-01
	Stk	Gas Valve - LP	See Note 2	See Note 2
	Stk,3	Integrated Furnace Control Board (IFC)	62-102860-02	62-102860-02
		Street Elbow	81-17487-01	81-17487-01
		Nipple	81-40683-03	81-40683-02
	Stk	LP Conversion Kit	EP-85H	EP-84W

No.	Notes	MODEL TECHNICAL VARIATION COOLING CAPACITY	RKNL- C 036-060
OPTIONS AND ACCESSORIES			
		DDC Economizer with Single Enthalpy and Barometric Relief (Neutra Green)	RXRD-TKCM3
		DDC Economizer with Single Enthalpy and Barometric Relief (Granite/Steel Gray)	AXRD-TKCM3
		DDC Economizer with Single Enthalpy, Smoke Detector and Barometric Relief (Neutra Green)	RXRD-UKCM3
		DDC Economizer with Single Enthalpy, Smoke Detector and Barometric Relief (Granite/Steel Gray)	AXRD-UKCM3
		Dual Enthalpy Kit	RXRX-AV03
		CO2 Sensor	RXRX-AR02
		Power Exhaust - C Voltage (Neutra Green)	RXRX-BGF04C
		Power Exhaust - C Voltage (Granite/Steel Gray)	AXRX-BGF04C
		Power Exhaust - D Voltage (Neutra Green)	RXRX-BGF04D
		Power Exhaust - D Voltage (Granite/Steel Gray)	AXRX-BGF04D
		Power Exhaust - Y Voltage (Neutra Green)	RXRX-BGF04Y
		Power Exhaust - Y Voltage (Granite/Steel Gray)	AXRX-BGF04Y
		Fresh Air Damper Manual (Neutra Green)	RXRF-FBA1
		Fresh Air Damper Manual (Granite/Steel Gray)	AXRF-FBA1
		Fresh Air Damper Motorized (Neutra Green)	RXRF-FBB1
		Fresh Air Damper Motorized (Granite/Steel Gray)	AXRF-FBB1
		Louver Kit - (3 Sides) (Neutra Green)	RXRX-AAD01B
		Louver Kit - (3 Sides) (Granite/Steel Gray)	AXRX-AAD01B
		Comfort Alert	RXRX-AZ01
		BACnet Communication Card	RXRX-AY01
		Lonworks Communication Card	RXRX-AY02
		Low Ambient Control	RXRZ-A04

No.	Notes	MODEL TECHNICAL VARIATION COOLING CAPACITY	RKNL- C 072-151
ACCESSORIES			
		Louver Panel - Option (6 - 10 Ton) (Neutra Green)	RXRX-AAD01C
		Louver Panel - Option (6 - 10 Ton) (Granite/Steel Gray)	AXRX-AAD01C
		Carbon Dioxide Sensor	RXRX-AR02
		Dual Enthalpy Kit	RXRX-AV02
		Manual Fresh Air (Left Panel Mounted) (Neutra Green)	RXRF-KDA1
		Manual Fresh Air (Left Panel Mounted) (Granite/Steel Gray)	AXRF-KDA1
		Motor Kit for ()XRF-KDA1	RXRX-AW02
		Manual Fresh Air (Return Panel) (Neutra Green)	RXRF-JDA1
		Manual Fresh Air (Return Panel) (Granite/Steel Gray)	AXRF-JDA1
		Motorized Fresh Air (Return Panel) (Neutra Green)	RXRF-JDB1
		Motorized Fresh Air (Return Panel) (Granite/Steel Gray)	AXRF-JDB1
		Time Delay Relay - Option	RXMD-A04
		Freeze Stat - Option	RXRX-AM01
		Convenience Outlet - Option	RXRX-AN01
		Low Ambient Control Kit (One per Compressor)	RXRZ-C02

No.	Notes	MODEL TECHNICAL VARIATION COOLING CAPACITY	RKNL- C 072-151
ECONOMIZERS			
		Economizer - Single Enthalpy (Neutra Green)	RXRD-PJCM3
		Economizer - Single Enthalpy (Granite/Steel Gray)	AXRD-PJCM3
		Economizer - Single Enthalpy w/Smoke Detector (Neutra Green)	RXRD-SJCM3
		Economizer - Single Enthalpy w/Smoke Detector (Granite/Steel Gray)	AXRD-SJCM3

No.	Notes	MODEL TECHNICAL VARIATION COOLING CAPACITY	RKNL- C 072-151
POWER EXHAUST			
		Power Exhaust	RXRX-BFF02C
		Power Exhaust	RXRX-BFF02D
		Power Exhaust	RXRX-BFF02Y

No.	Notes	MODEL TECHNICAL VARIATION COOLING CAPACITY	RKNL- C 180-300
ACCESSORIES			
		Carbon Dioxide Sensor	RXR-AR02
		Dual Enthalpy Kit	RXR-AV02
		Manual Fresh Air Damper (Neutra Green)	RXR-KFA1
		Manual Fresh Air Damper (Granite/Steel Gray)	AXR-KFA1
		Motorized Kit for RXR-KFA1/AXR-KFA1	RXR-AW03
		Freeze Stat Kit	RXR-AM03
		Unwired Convenience Outlet	RXR-AN01
		Unfused Service Disconnect	RXR-AP01
		Low Ambient Control Kit (One per Compressor)	RXR-C02
		Louver Panel Kit (Hail Guard) - Left and Right (Granite/Steel Gray)	AXR-AAD01L

No.	Notes	MODEL TECHNICAL VARIATION COOLING CAPACITY	RKNL- C 180-300
ECONOMIZERS			
		Economizer (Neutra Green)	RXR-PMCM3
		Economizer (Granite/Steel Gray)	AXR-PMCM3
		Economizer (Neutra Green)	RXR-SMCM3
		Economizer (Granite/Steel Gray)	AXR-SMCM3

No.	Notes	MODEL TECHNICAL VARIATION COOLING CAPACITY	RKNL- C 180-300
POWER EXHAUST			
		Power Exhaust	RXR-BGF05C
		Power Exhaust	RXR-BGF05D
		Power Exhaust	RXR-BGF05Y

PACKAGE EQUIPMENT - ORIFICE SELECTION CHART - NATURAL GAS

CAUTION: Selection of the correct Natural Gas Orifice requires the following information for the specific installation:

- 1) Furnace Input Rating (BTU/HR)
- 2) Number of Burners
- 2) Altitude (ft.)

For detailed information and instructions for Orifice selection, see the Gas Furnace LP Conversion Kit Index 92-21519-47 and the latest edition of the National Fuel Gas Code Handbook, or the National Standard of Canada, Natural Gas and Propane Installation Code, CAN B149.1.

CAUTION: This information is provided for replacement purposes only. Conversion for operation at High Altitude must be done using the kit specified on the product specification sheet for the unit.

NOTE: This Orifice sizing chart is based on a Natural Gas heating value of 1075 BTU/cu. ft and a pressure setting of 3.5 in. water column.

NOTE: Factory installed orifices are calculated and sized based on a Natural Gas heating value of 1075 BTU/cu. ft. and an elevation of 0 - 2000 ft.

Furnace Input Rating (BTU/HR)	Canadian High Altitude Derated Input (BTU/HR)	Number of Burners	Elevation (ft.)					
			Country					
			0 - 2000 U.S.	2001 - 4000 U.S.	4001 - 6000 U.S.	8000+ U.S.	0 - 2000 Canada	2001 - 4500 Canada
40,000	36,000	2	62-22175-45	62-22175-47	62-22175-48	62-22175-49	62-22175-45	62-22175-15
60,000	54,000	3	62-22175-45	62-22175-47	62-22175-48	62-22175-49	62-22175-45	62-22175-15
72,000	N/A	4	62-22175-15	62-22175-49	62-22175-50	62-22175-51	62-22175-15	N/A
80,000	72,000	4	62-22175-45	62-22175-47	62-22175-48	62-22175-49	62-22175-45	62-22175-15
90,000	N/A	5	62-22175-15	62-22175-49	62-22175-50	62-22175-51	62-22175-15	N/A
100,000	90,000	5	62-22175-45	62-22175-47	62-22175-48	62-22175-49	62-22175-45	62-22175-15
120,000	108,000	6	62-22175-45	62-22175-47	62-22175-48	62-22175-49	62-22175-45	62-22175-15
135,000	121,500	6	62-22175-44	62-22175-45	62-22175-47	62-22175-48	62-22175-44	62-22175-45
150,000	135,000	6	62-22175-42	62-22175-43	62-22175-44	62-22175-45	62-22175-42	62-22175-44
180,000	N/A	9	62-22175-45	62-22175-47	62-22175-48	62-22175-49	62-22175-45	N/A
210,000	N/A	9	62-22175-43	62-22175-44	62-22175-45	62-22175-47	62-22175-43	N/A
210,000	N/A	10	62-22175-45	62-22175-47	62-22175-48	62-22175-49	62-22175-45	N/A
225,000	202,500	9	62-22175-42	62-22175-43	62-22175-44	62-22175-45	62-22175-42	62-22175-44
250,000	225,000	10	62-22175-42	62-22175-43	62-22175-44	62-22175-45	62-22175-42	62-22175-44
252,000	225,000	9	62-22175-40	62-22175-42	62-22175-43	62-22175-44	62-22175-40	62-22175-42
252,000	N/A	12	62-22175-45	62-22175-47	62-22175-48	62-22175-49	62-22175-45	N/A
290,000	N/A	14	62-22175-45	62-22175-47	62-22175-48	62-22175-49	62-22175-45	N/A
300,000	270,000	12	62-22175-42	62-22175-43	62-22175-44	62-22175-45	62-22175-42	62-22175-44
330,000	N/A	14	62-22175-43	62-22175-44	62-22175-45	62-22175-47	62-22175-43	N/A
350,000	315,000	14	62-22175-42	62-22175-43	62-22175-44	62-22175-45	62-22175-42	62-22175-44
400,000	360,000	14	62-22175-40	62-22175-42	62-22175-43	62-22175-44	62-22175-40	62-22175-42

PACKAGE EQUIPMENT - ORIFICE SELECTION CHART - LP

CAUTION: Selection of the correct LP Orifice requires the following information for the specific installation:

- 1) Furnace Input Rating (BTU/HR)
- 2) Number of Burners
- 2) Altitude (ft.)

For detailed information and instructions for Orifice selection, see the Gas Furnace LP Conversion Kit Index 92-21519-47 and the latest edition of the National Fuel Gas Code Handbook, or the National Standard of Canada, Natural Gas and Propane Installation Code, CAN B149.1.

CAUTION: This information is provided for replacement purposes only. Conversion to LP or for operation at High Altitude should be done using the kit(s) specified on the product specification sheet for the unit.

NOTE: This Orifice sizing chart is developed using the specified pressure setting of 10 in. water column instead of the 11.0 in water column used by the NFG and CANB149.1.

NOTE: Orifices supplied in the LP Conversion Kit are calculated and sized based on a heating value of 2500 BTU/cu. ft. and an elevation of 0 - 2000 ft.

Furnace Input Rating (BTU/HR)	Canadian High Altitude Derated Input (BTU/HR)	Number of Burners	Elevation (ft.)					
			Country					
			0 - 2000 U.S.	2001 - 4000 U.S.	4001 - 6000 U.S.	8000+ U.S.	0 - 2000 Canada	2001 - 4500 Canada
40,000	36,000	2	62-22175-55	62-22175-55	62-22175-56	62-22175-56	62-22175-55	62-22175-13
60,000	54,000	3	62-22175-55	62-22175-55	62-22175-56	62-22175-56	62-22175-55	62-22175-13
72,000	N/A	4	62-22175-13	62-22175-57	62-22175-57	62-22175-59	62-22175-13	N/A
80,000	72,000	4	62-22175-55	62-22175-55	62-22175-56	62-22175-56	62-22175-55	62-22175-13
90,000	N/A	5	62-22175-13	62-22175-57	62-22175-57	62-22175-59	62-22175-13	N/A
100,000	90,000	5	62-22175-55	62-22175-55	62-22175-56	62-22175-56	62-22175-55	62-22175-13
120,000	108,000	6	62-22175-55	62-22175-55	62-22175-56	62-22175-56	62-22175-55	62-22175-13
135,000	121,500	6	62-22175-54	62-22175-55	62-22175-55	62-22175-56	62-22175-54	62-22175-55
150,000	135,000	6	62-22175-54	62-22175-55	62-22175-55	62-22175-56	62-22175-54	62-22175-54
180,000	N/A	9	62-22175-55	62-22175-55	62-22175-56	62-22175-56	62-22175-55	N/A
210,000	N/A	9	62-22175-54	62-22175-55	62-22175-55	62-22175-56	62-22175-54	N/A
210,000	N/A	10	62-22175-55	62-22175-55	62-22175-56	62-22175-56	62-22175-55	N/A
225,000	202,500	9	62-22175-54	62-22175-55	62-22175-55	62-22175-56	62-22175-54	62-22175-54
250,000	225,000	10	62-22175-54	62-22175-55	62-22175-55	62-22175-56	62-22175-54	62-22175-54
252,000	225,000	9	62-22175-53	62-22175-54	62-22175-54	62-22175-55	62-22175-53	62-22175-54
252,000	N/A	12	62-22175-55	62-22175-55	62-22175-56	62-22175-56	62-22175-55	N/A
290,000	N/A	14	62-22175-55	62-22175-55	62-22175-56	62-22175-56	62-22175-55	N/A
300,000	270,000	12	62-22175-54	62-22175-55	62-22175-55	62-22175-56	62-22175-54	62-22175-54
330,000	N/A	14	62-22175-54	62-22175-55	62-22175-55	62-22175-56	62-22175-54	N/A
350,000	315,000	14	62-22175-54	62-22175-55	62-22175-55	62-22175-56	62-22175-54	62-22175-54
400,000	360,000	14	62-22175-53	62-22175-54	62-22175-54	62-22175-55	62-22175-53	62-22175-54

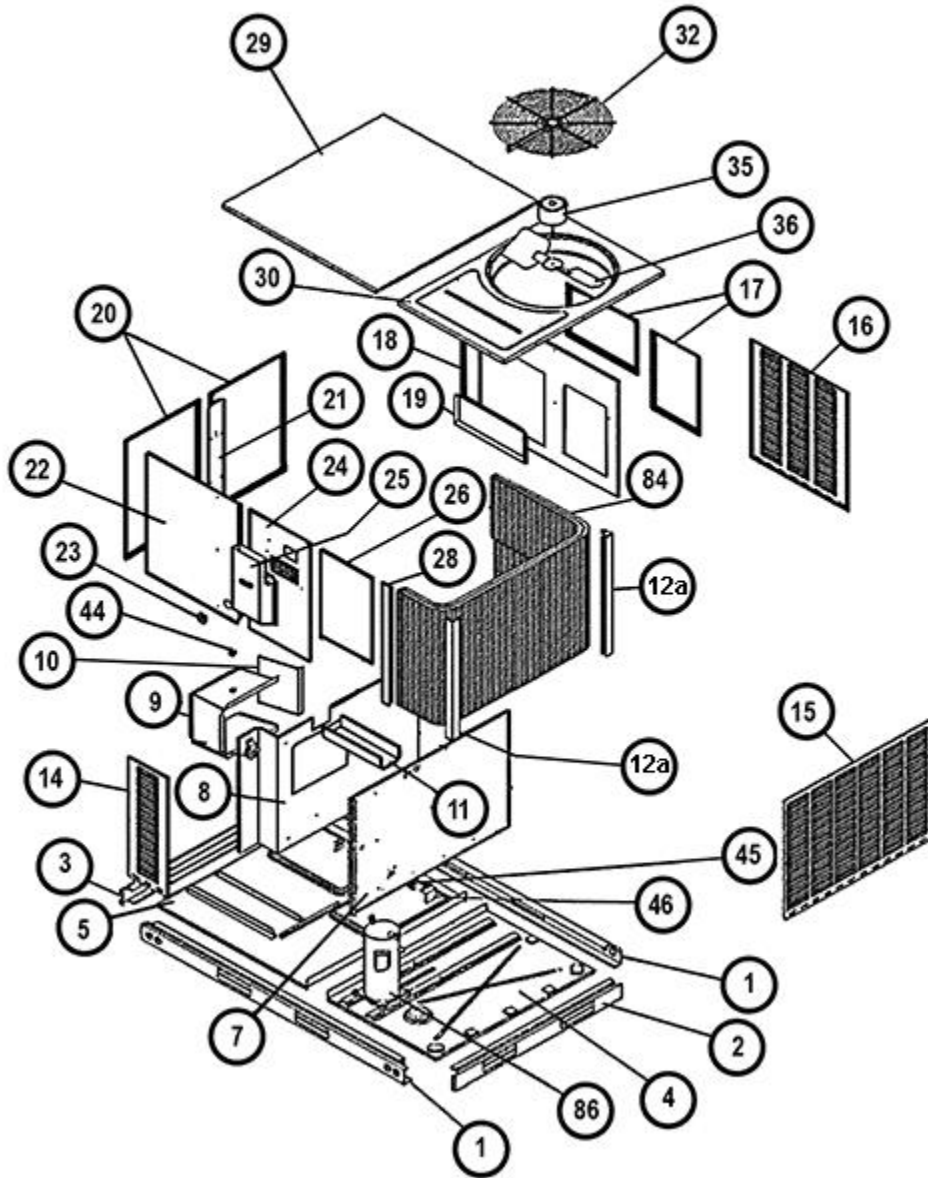

Exploded View 036-060

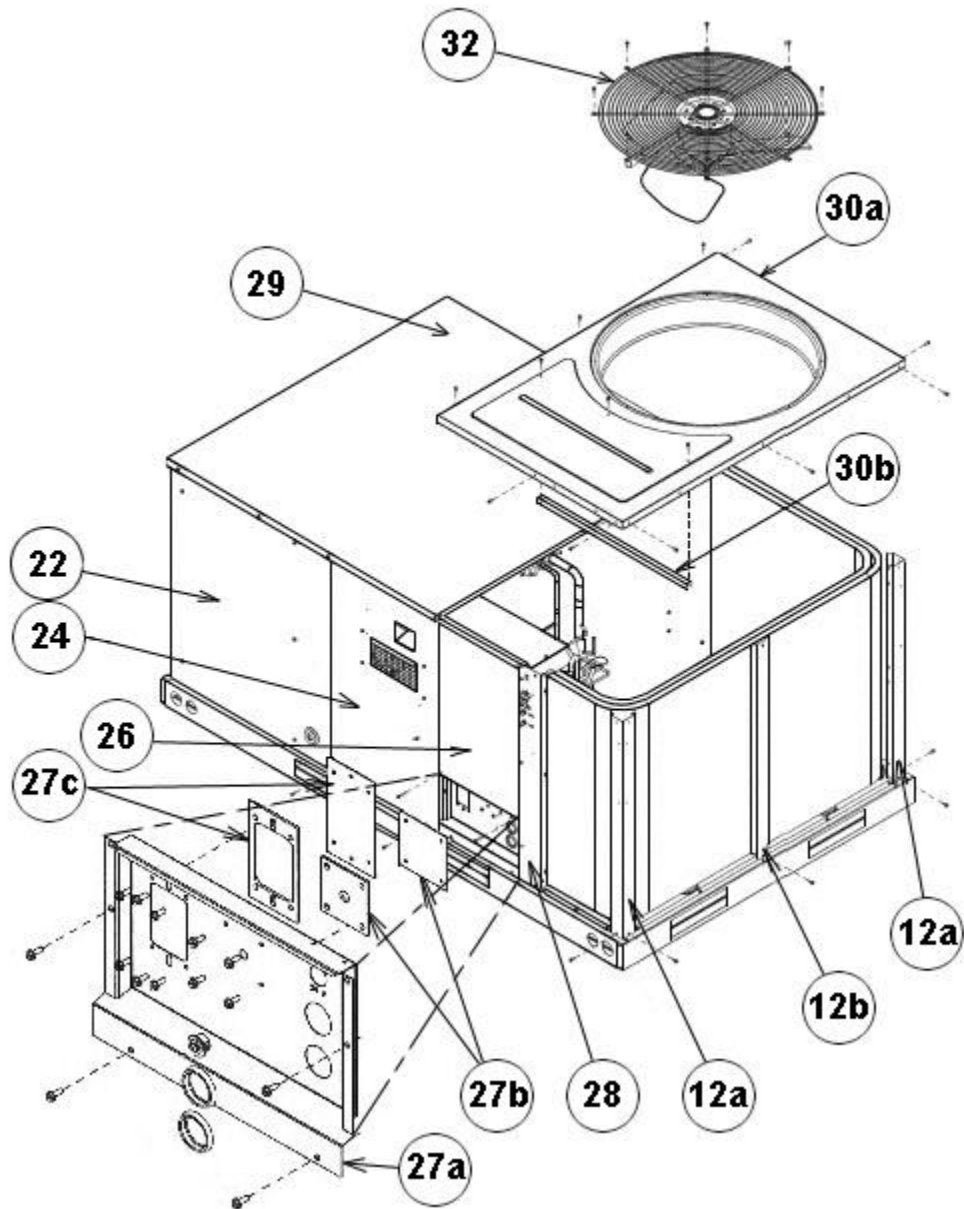

Top Panel View 036-060

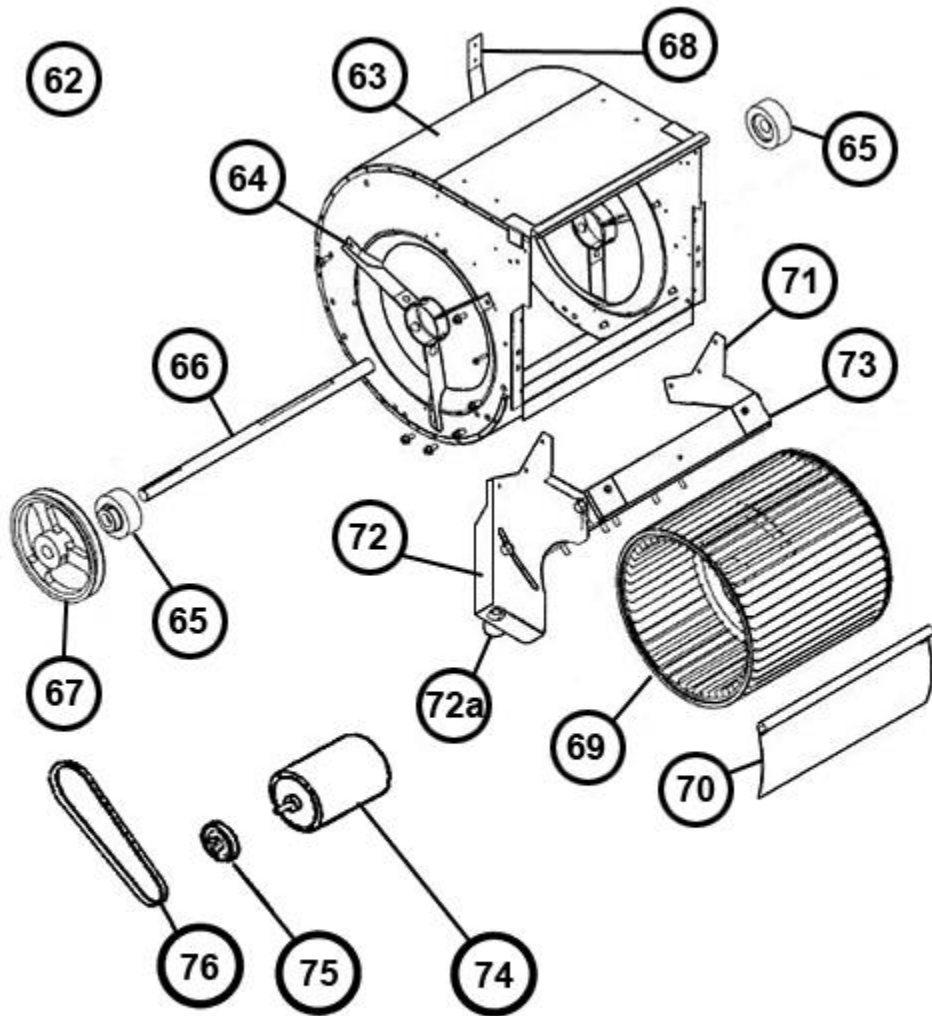

Blower Assembly - Belt Drive 036-060

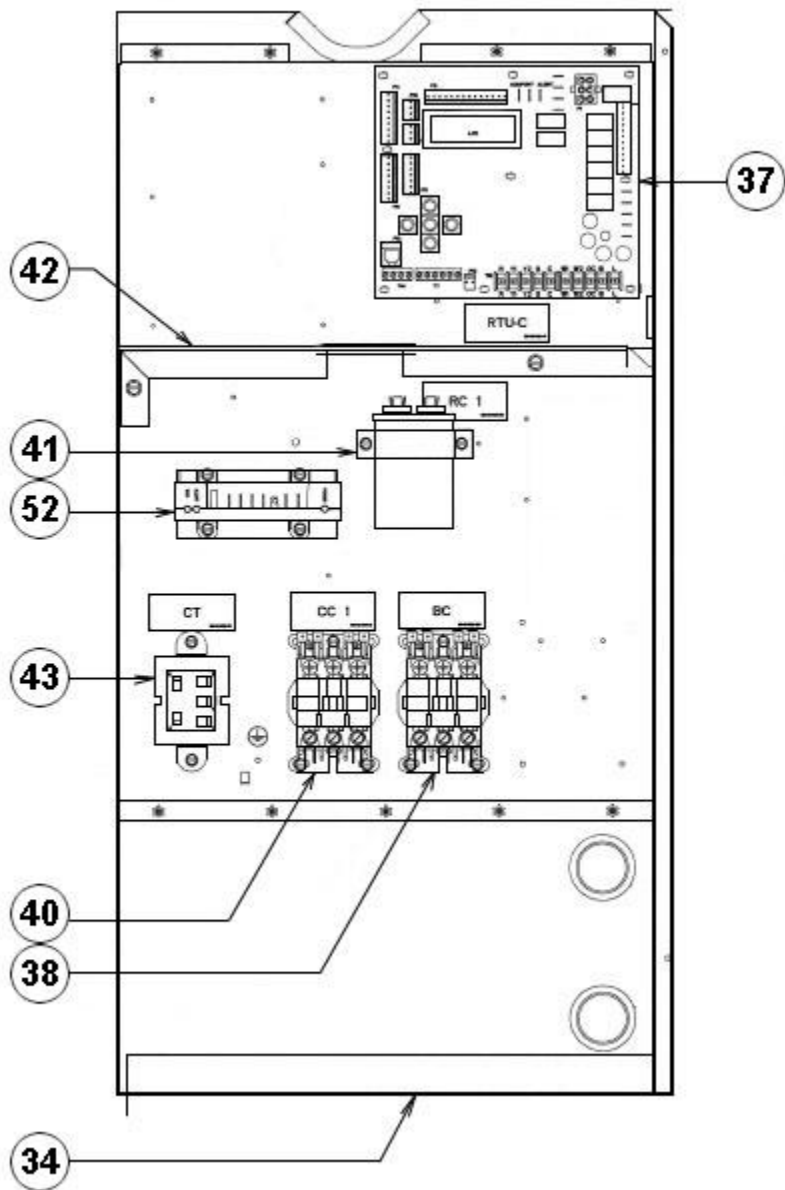

Control Box 036-060

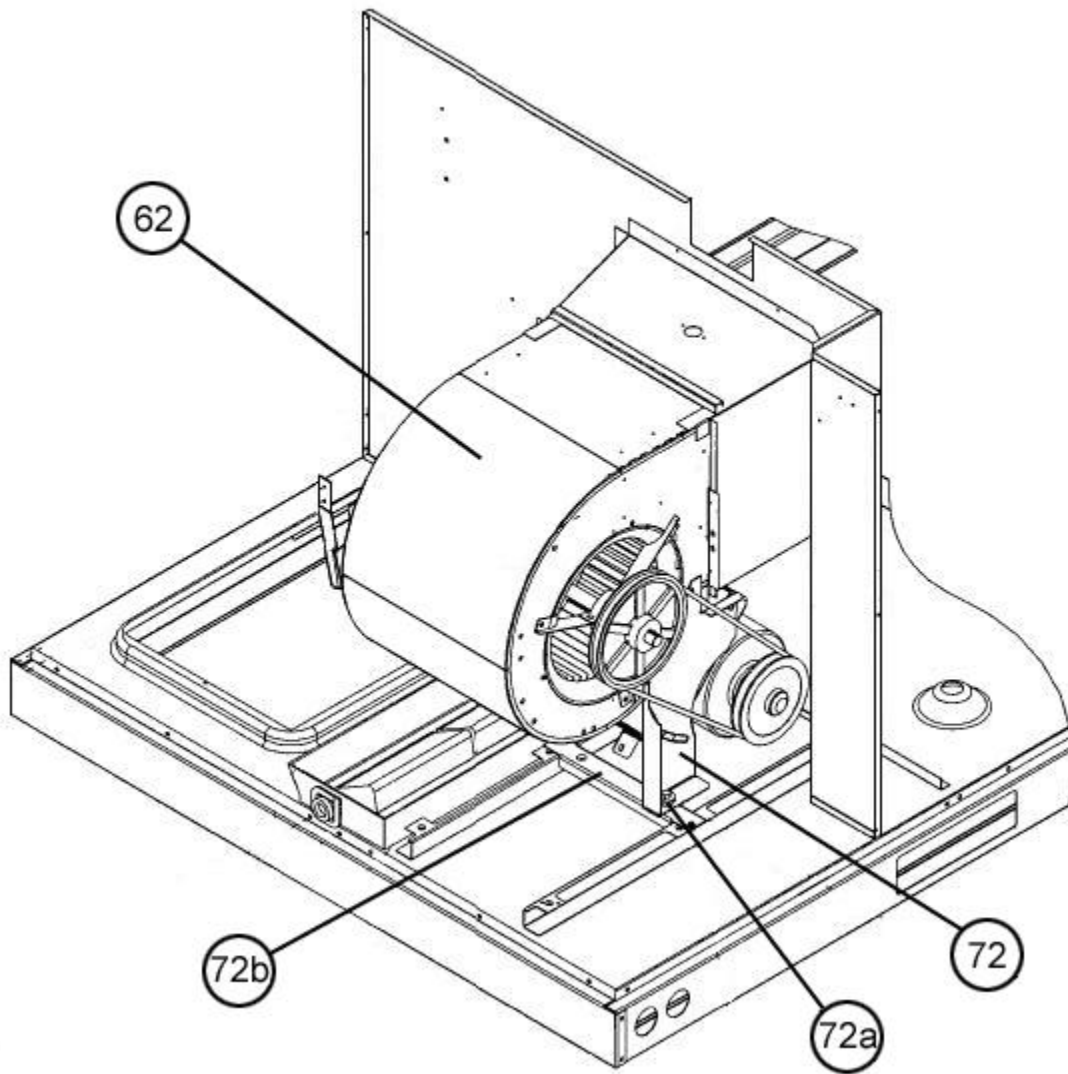

Blower Motor Mount Assembly - Belt Drive 030-060

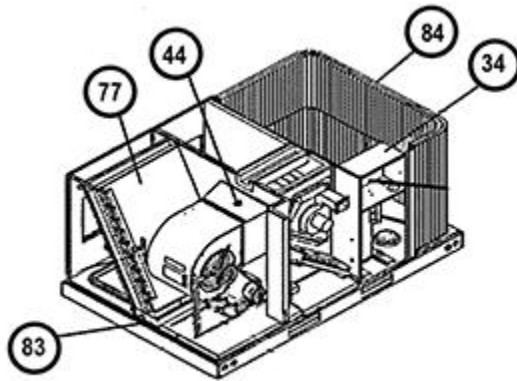

Coil Group Cut-away View 036-060

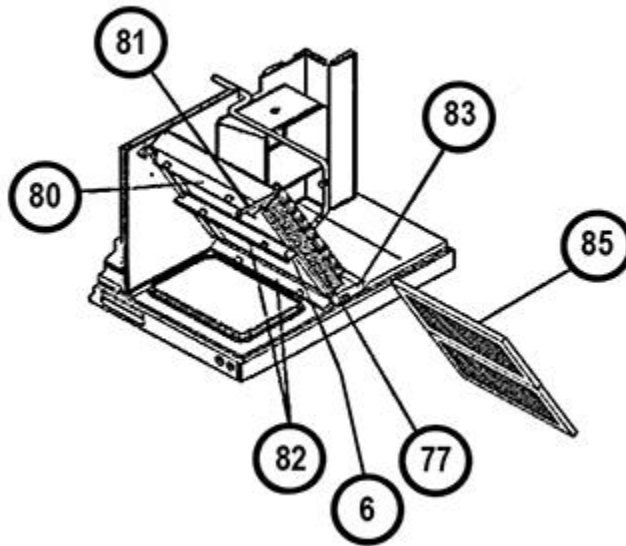

Evaporator Coil - Filter Parts 036-060

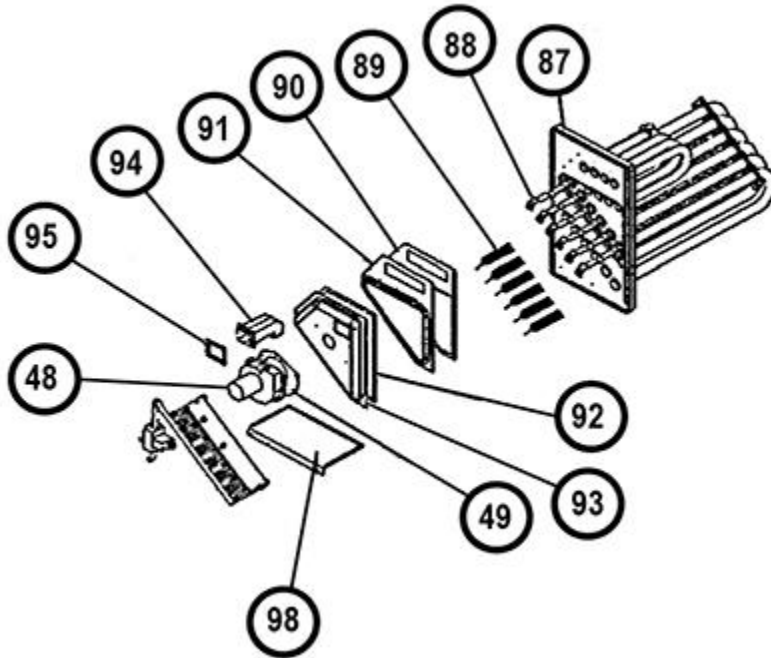

Heat Exchanger Assembly 036-060

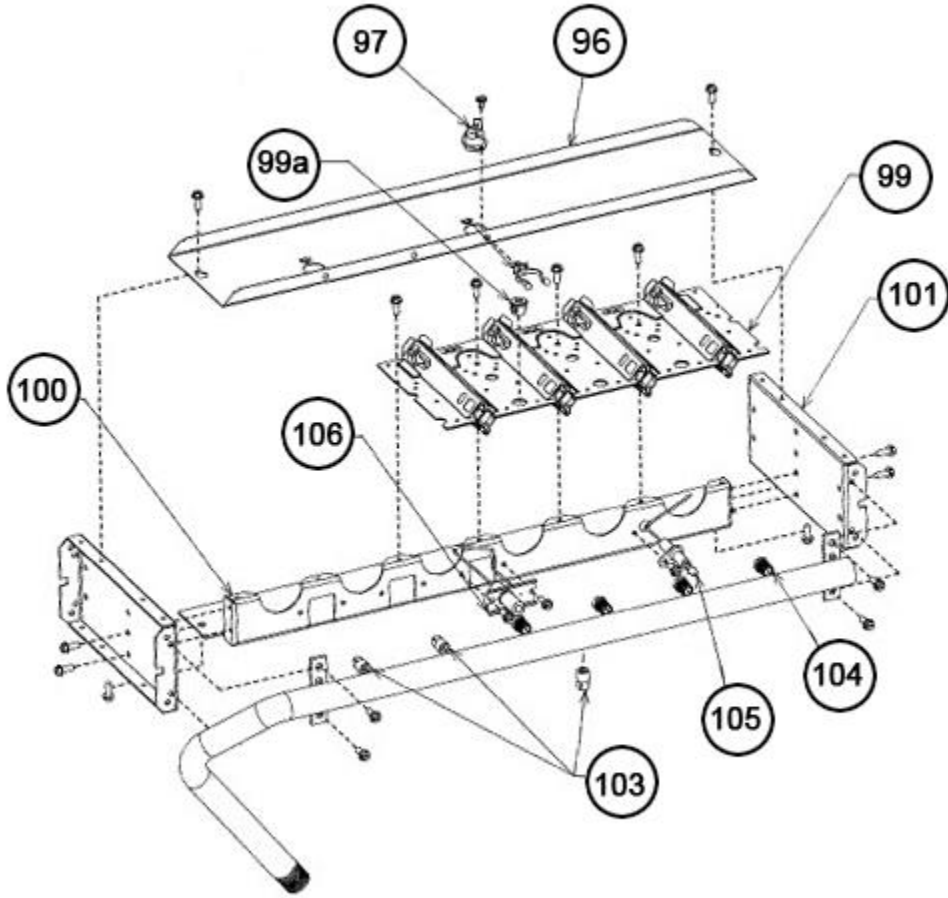

One Piece Burner Assembly 036-060

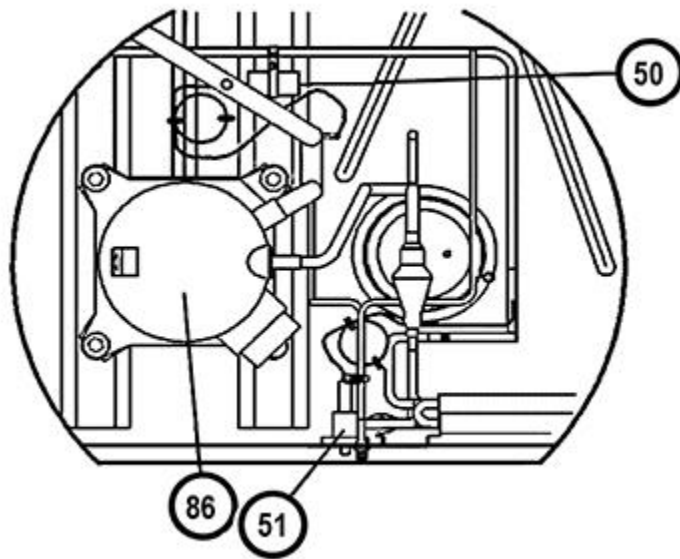

Compressor - Refrigeration Group 036-060

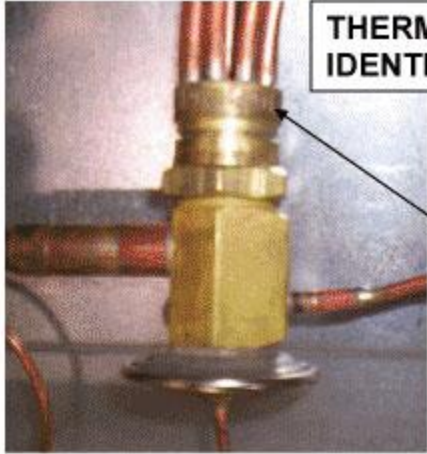

THERMAL EXPANSION VALVE MANUFACTURER IDENTIFICATION (For "N" Style Indoor Coils ONLY)

Sporlan Expansion Valves

Look for the name "SPORLAN" engraved on the base at the distributor body assembly.

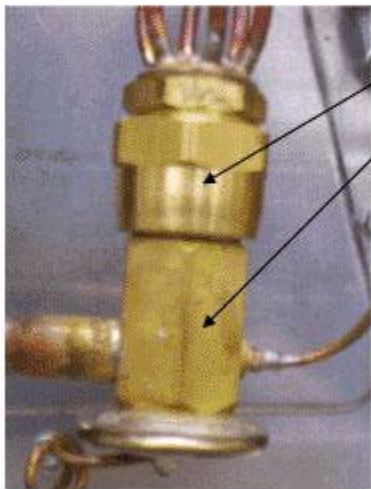

Parker Expansion Valves

The distributor body is larger (thicker) than the expansion valve body.



Emerson Expansion Valves

The expansion valve body is about two (2) inches long. Look between the arrows.

IMPORTANT NOTE:

To obtain the correct replacement TXV you must either:

- 1. Provide the EXACT TXV part number obtained by examining the unit.**
- 2. Provide a) The unit model number and b) the TXV manufacturer (determined by using this guide).**

TXV Identification Guide

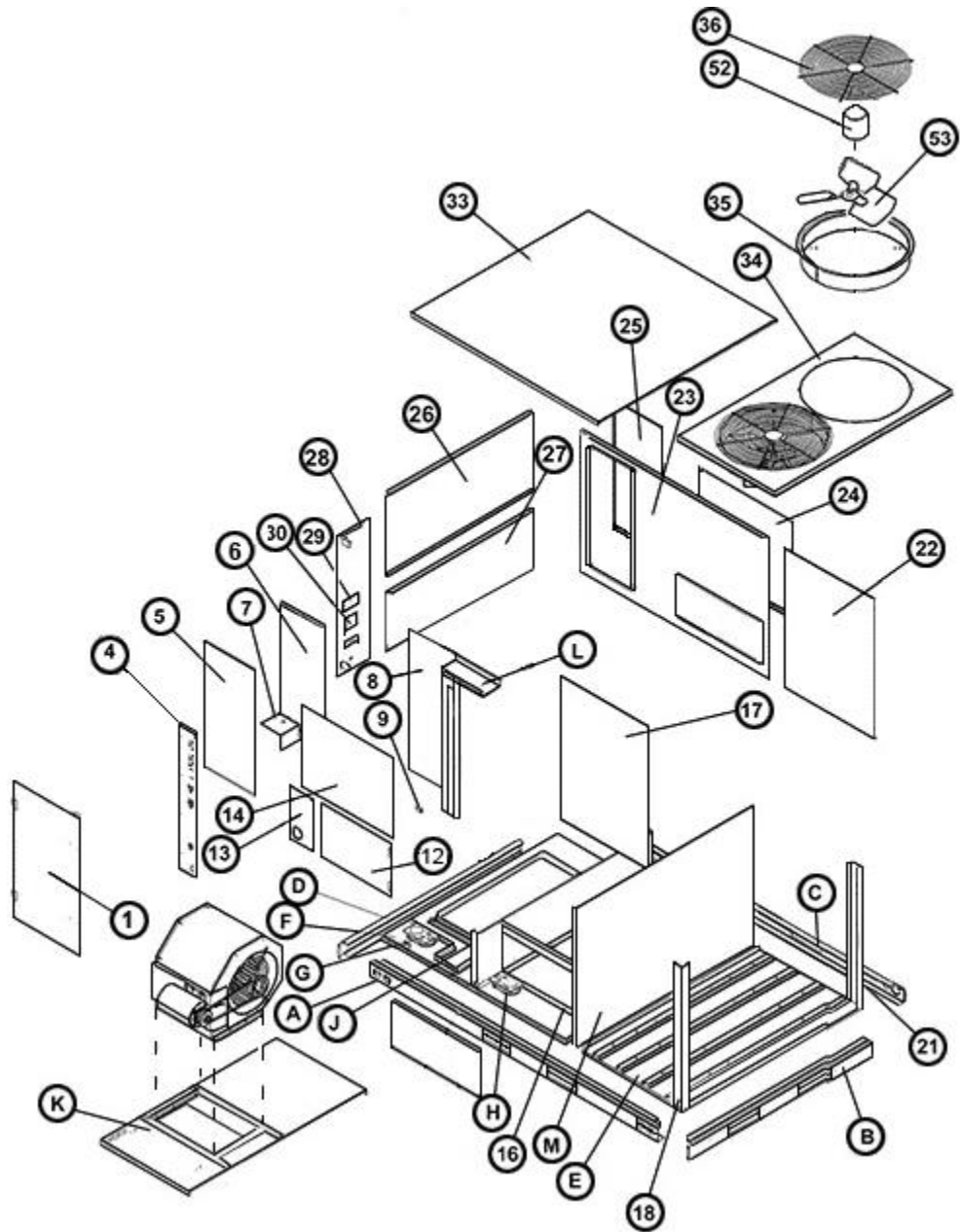

Exploded View 072-151

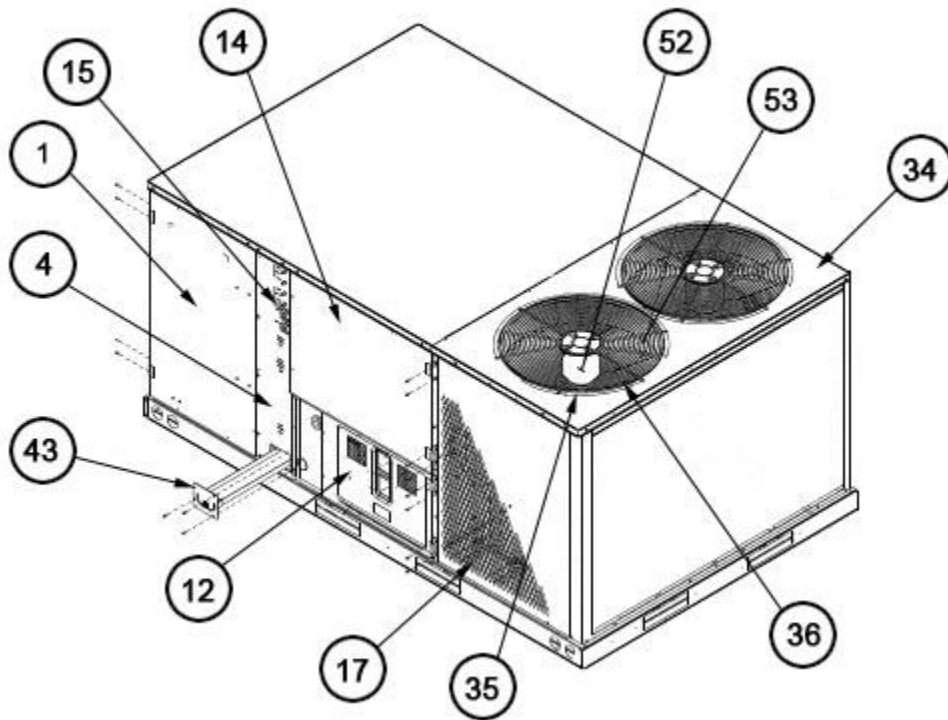

Exterior - Front 072-151

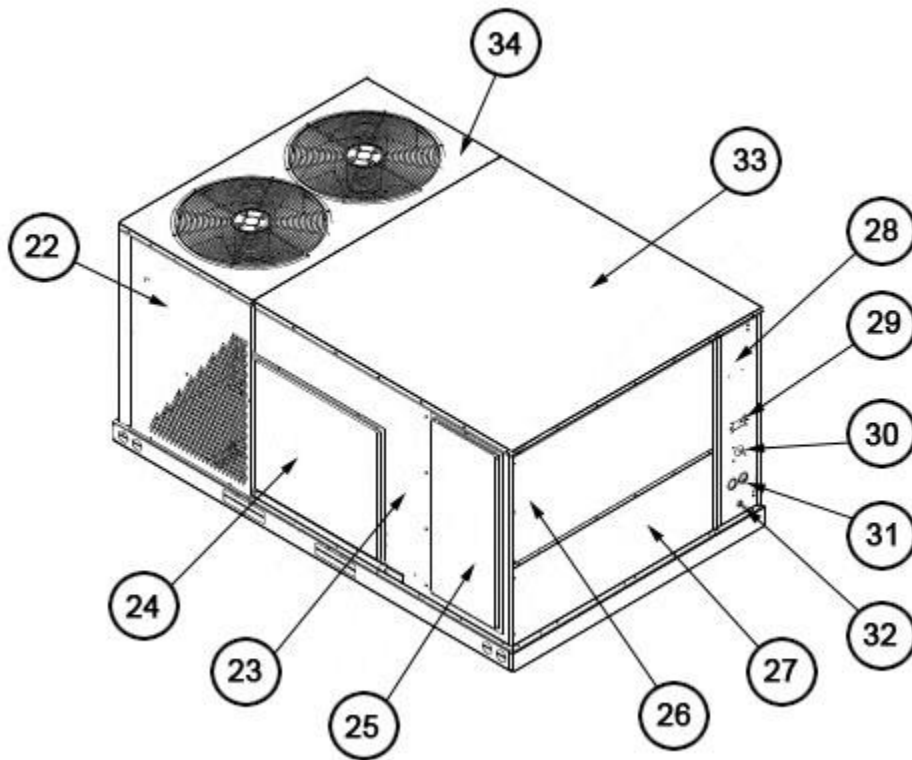

Exterior - Back 072-151

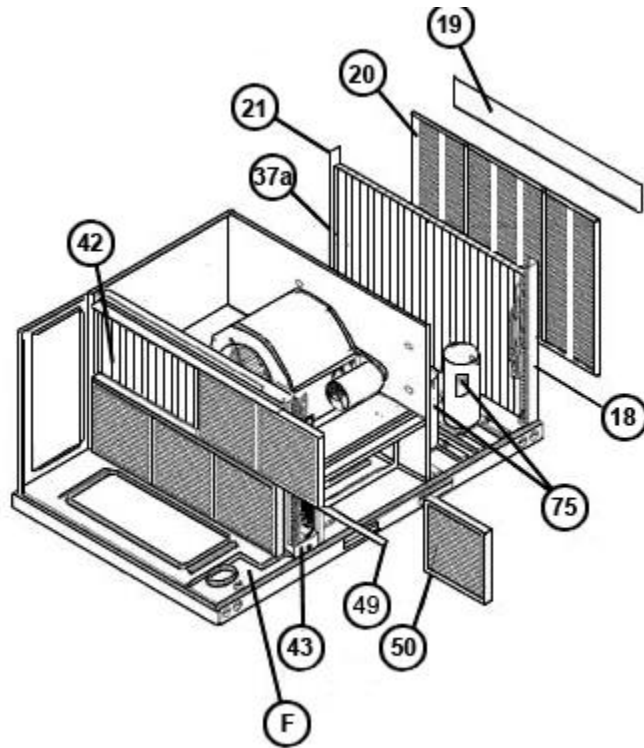

Filter-Coil Assembly 072-151

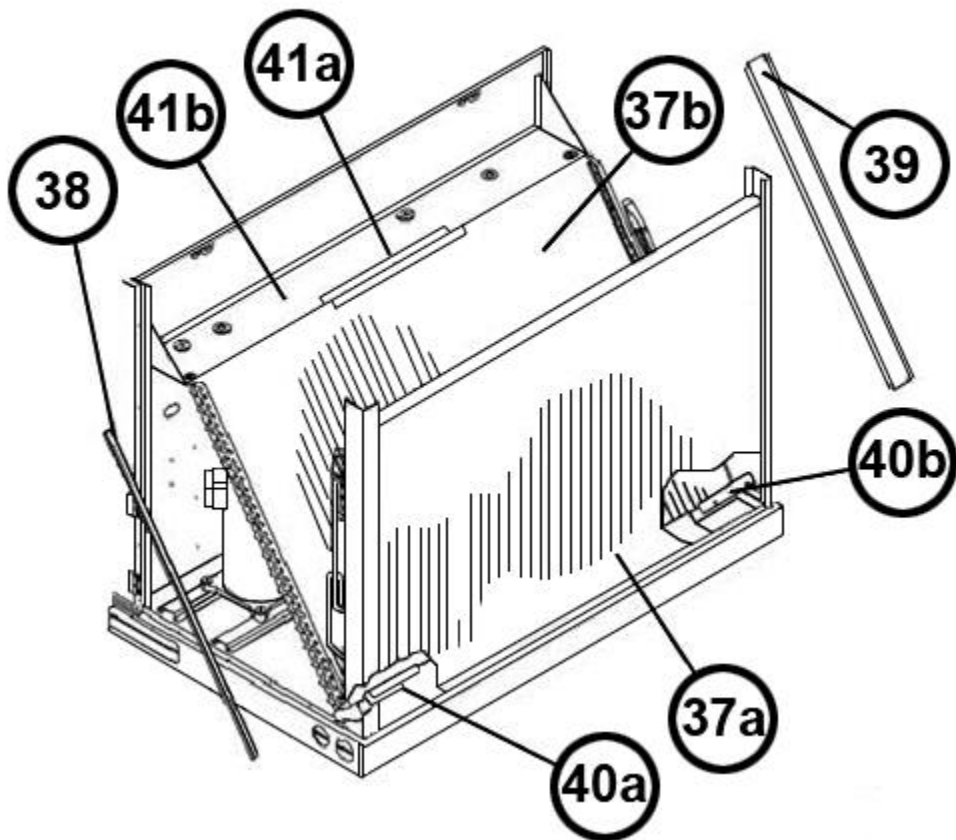

Condenser Coil Assembly 072-151

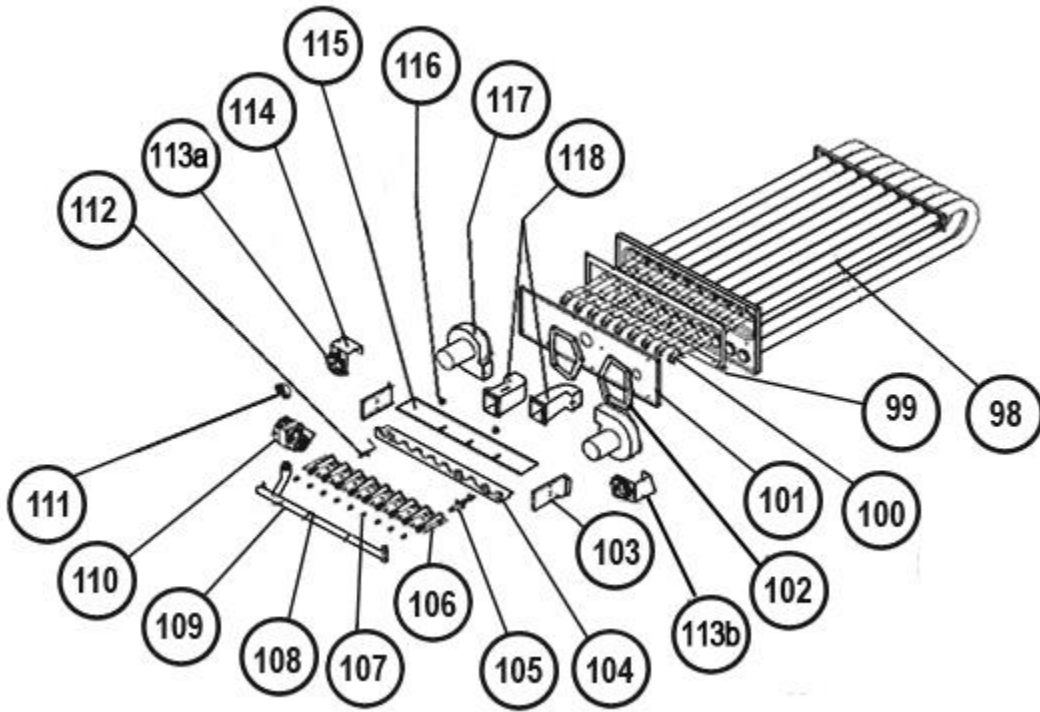

Heat Exchanger Assembly 072-151

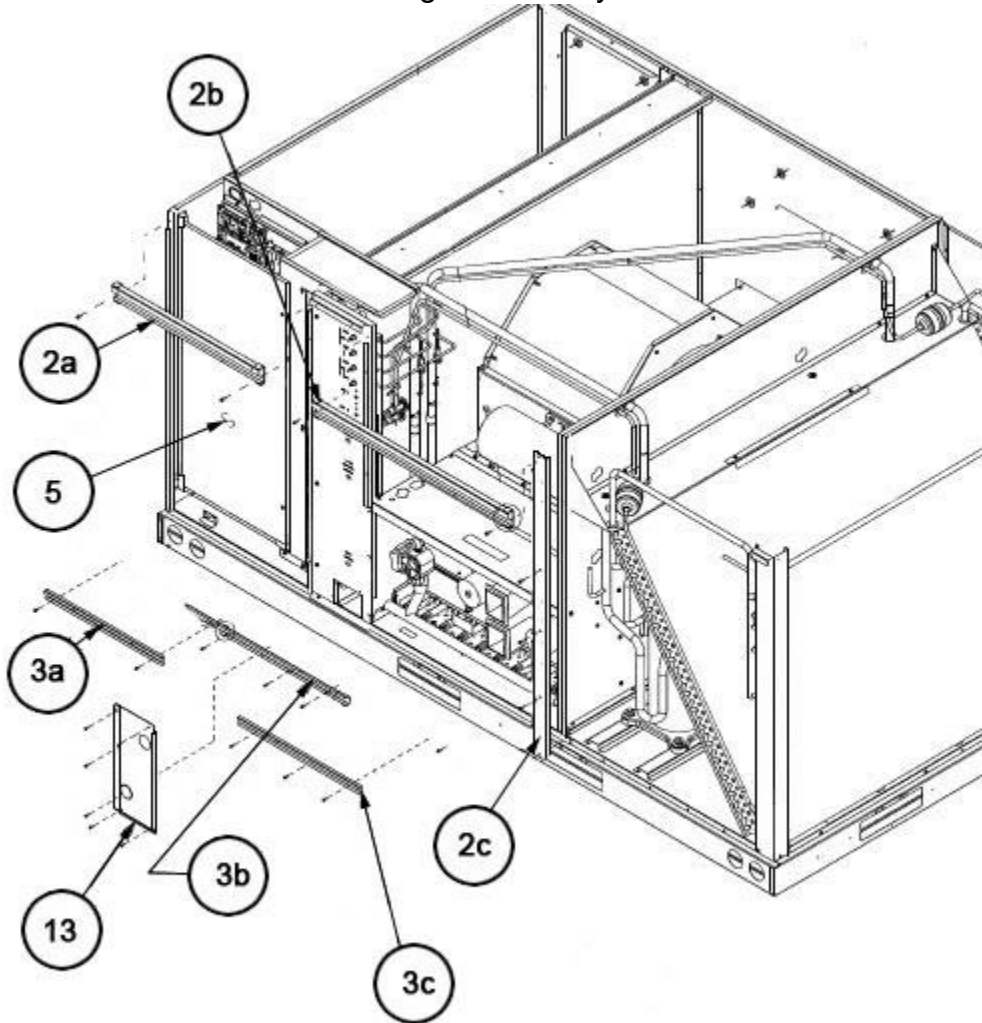

Front Panel Brackets 072-151

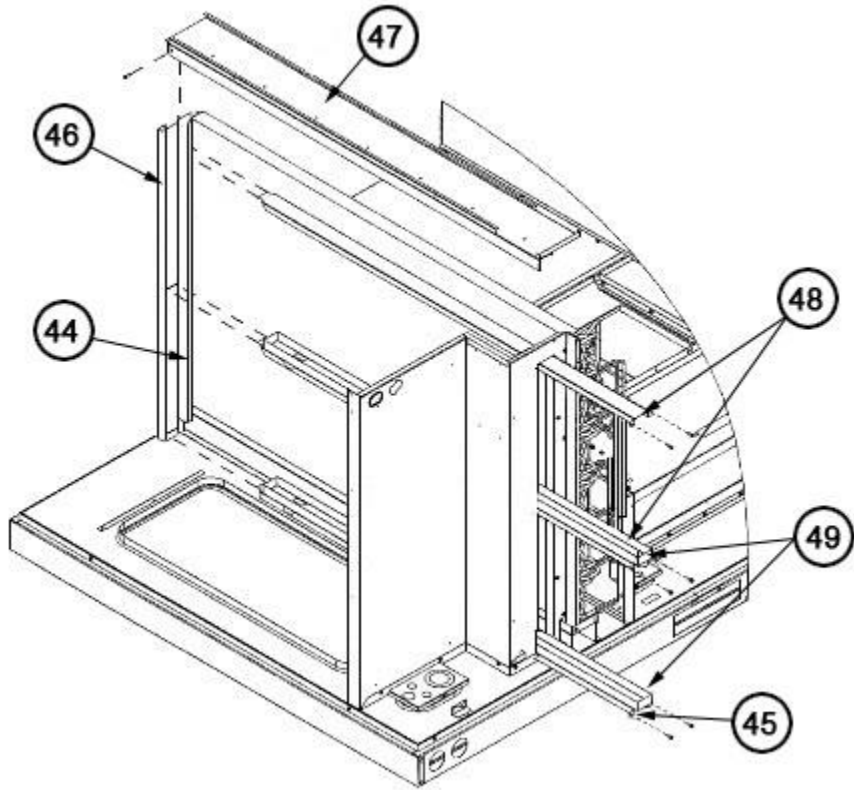

Filter Frame Assembly 072-151

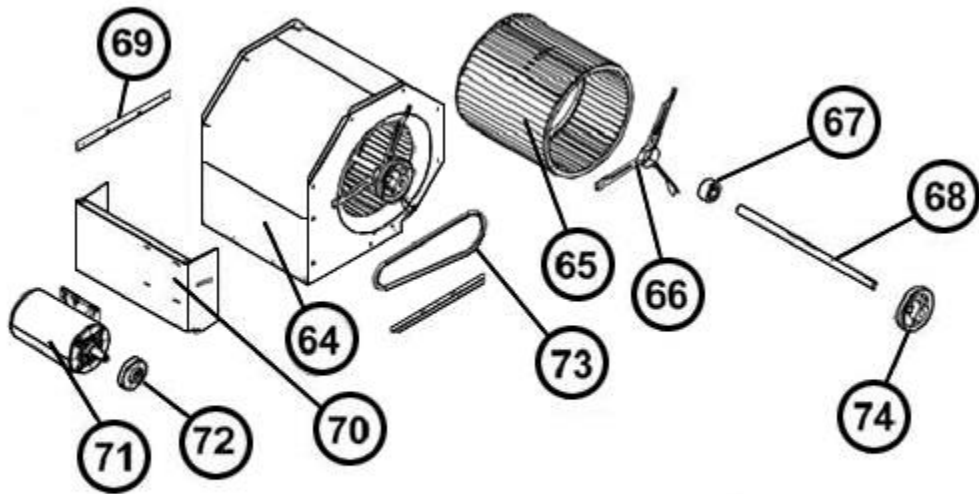

Blower Assembly 072-151

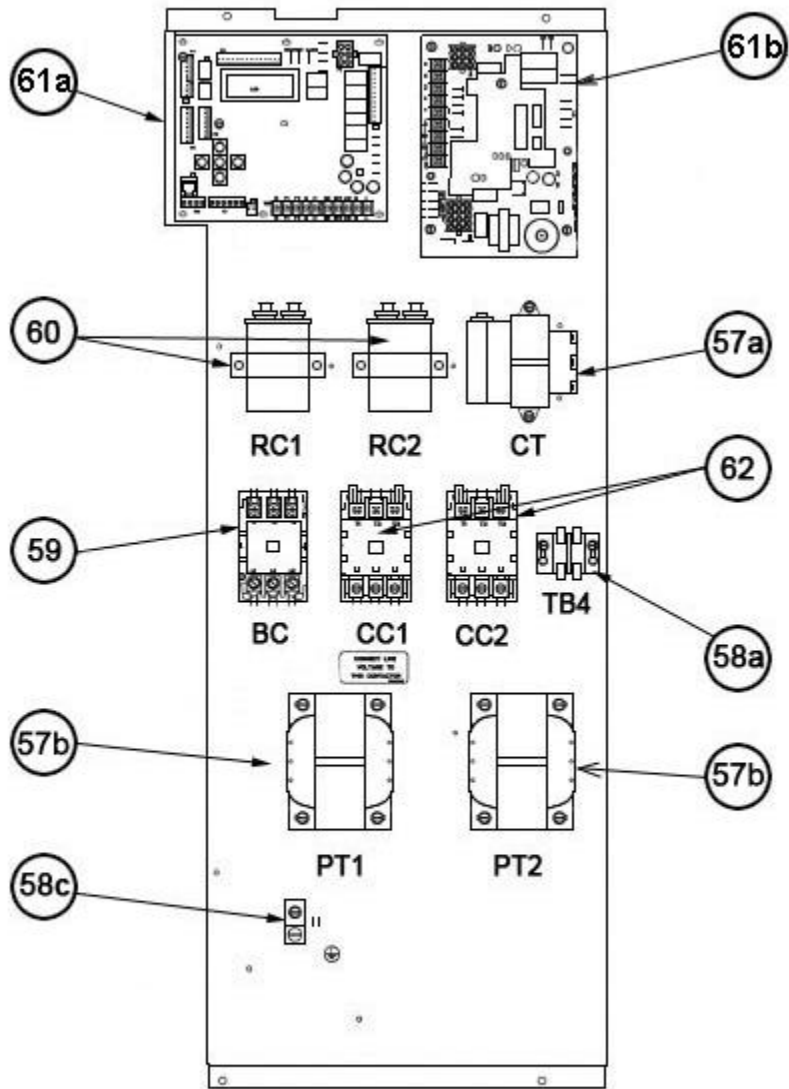

Control Box 072-151

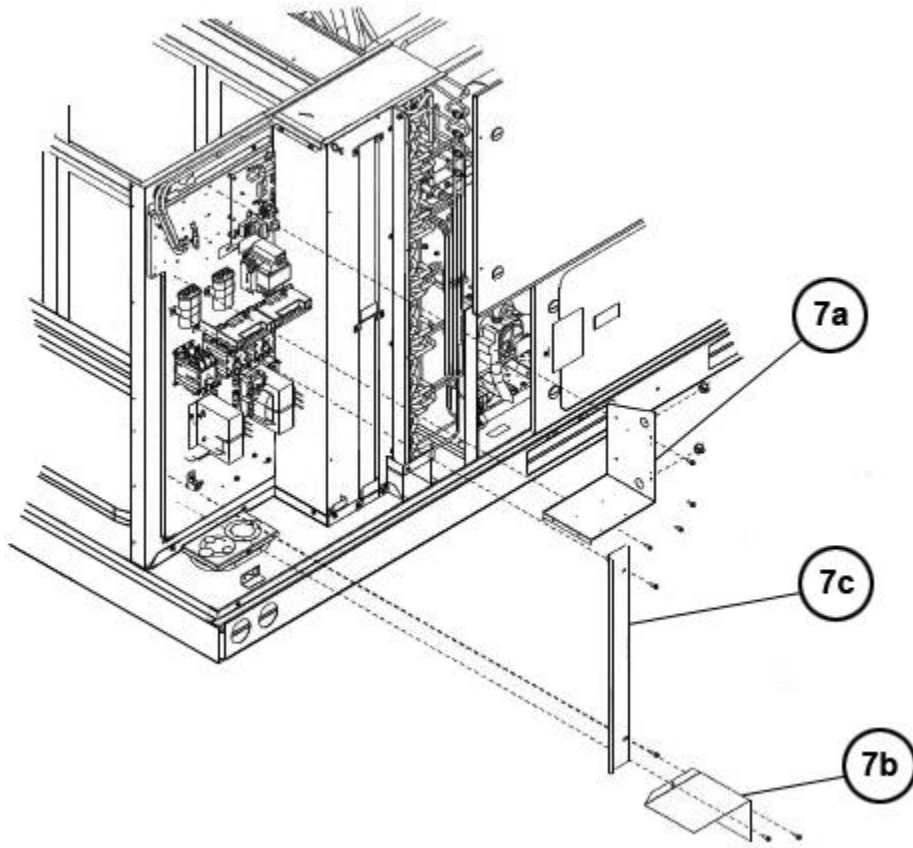

Low Voltage Shields 072-151

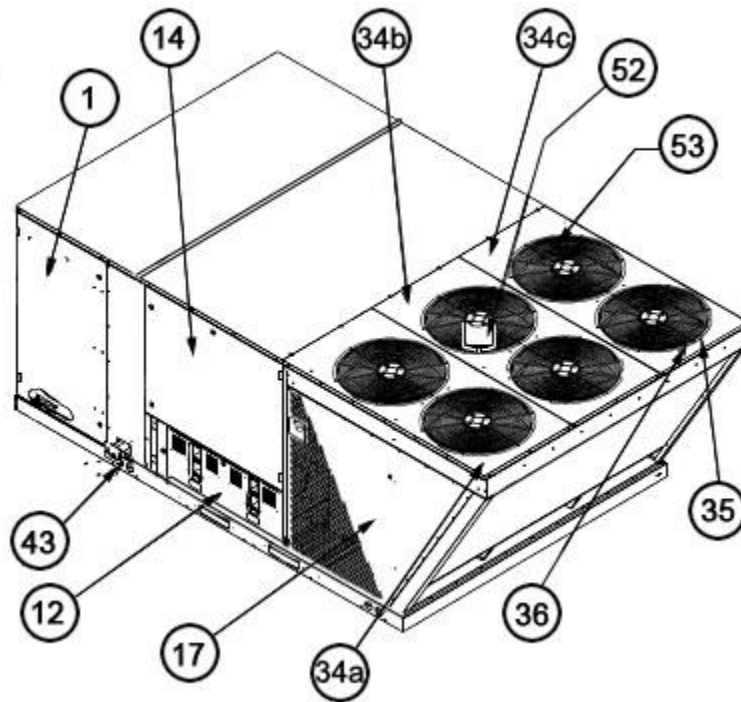

Exterior - Front 180-300

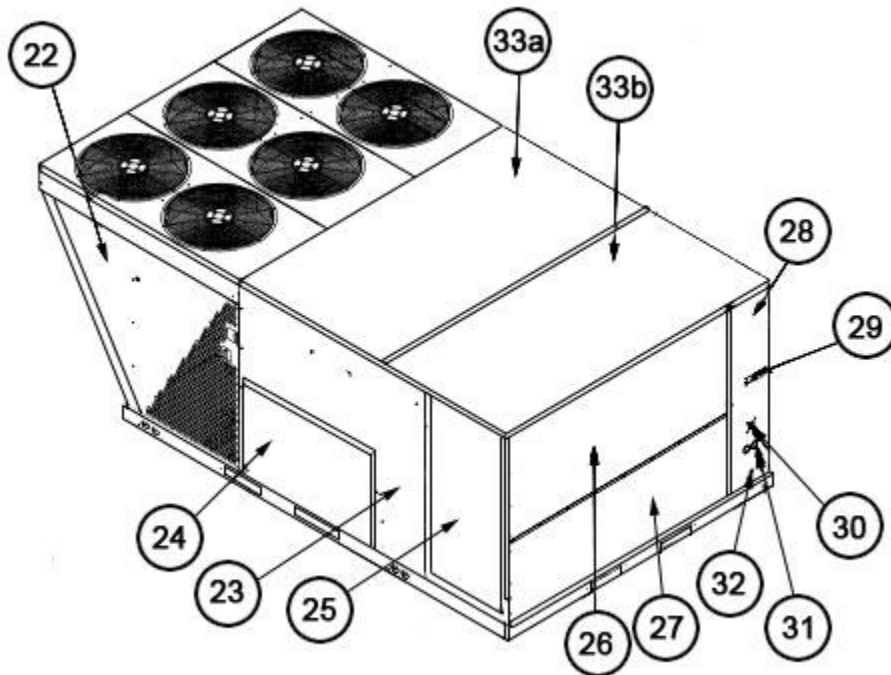

Exterior - Rear 180-300

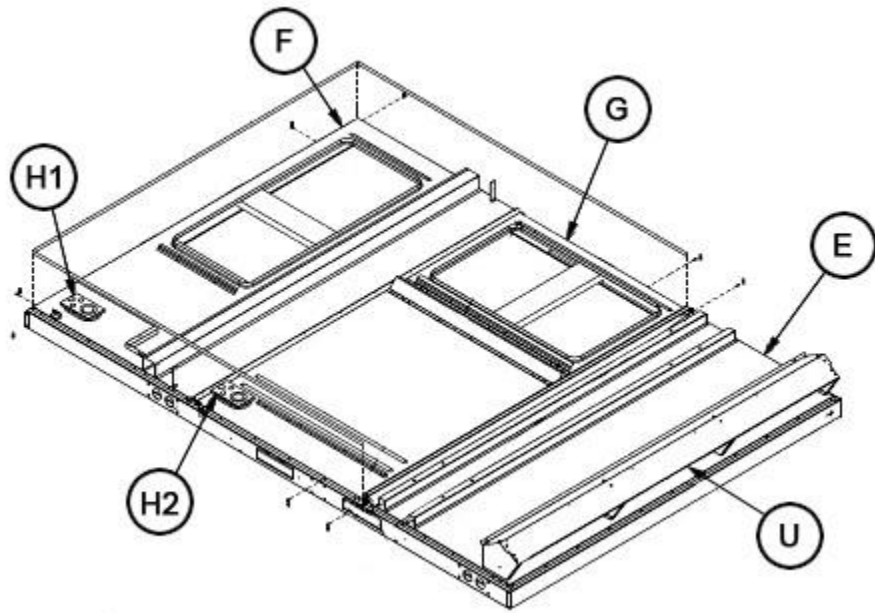

Base Pan Assembly 180-300

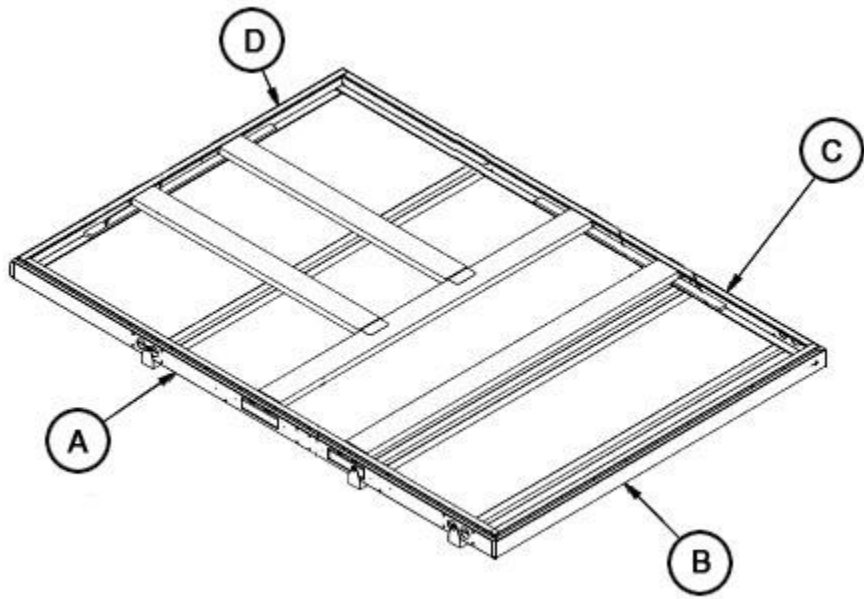

Base Rail Assembly 180-300

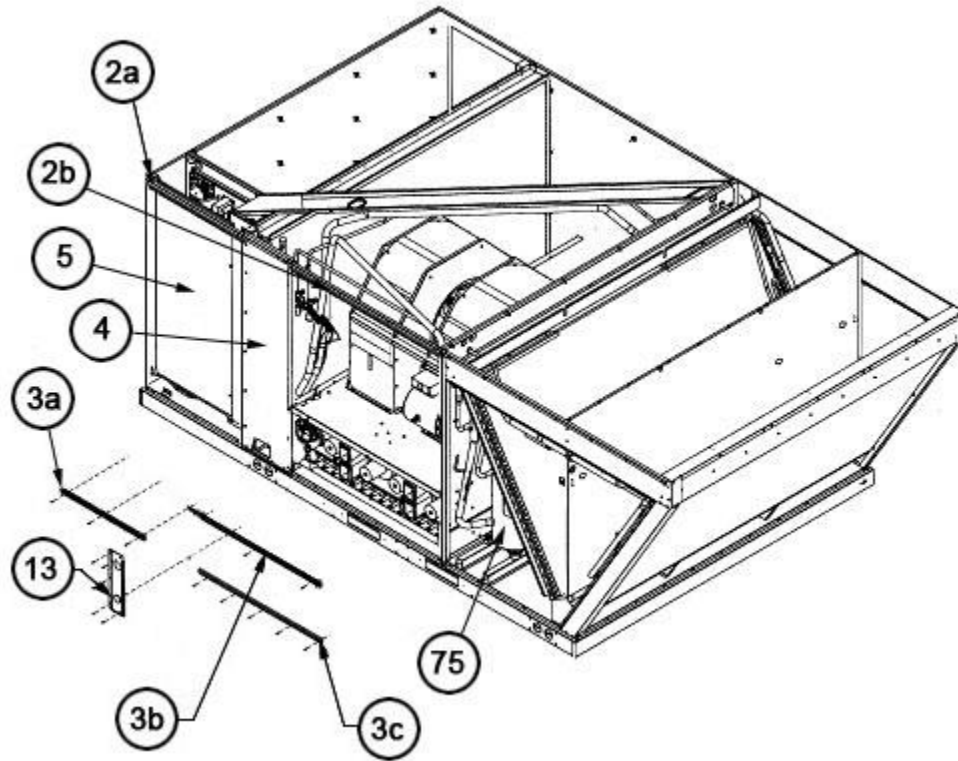

Front Panel Brackets 180-300

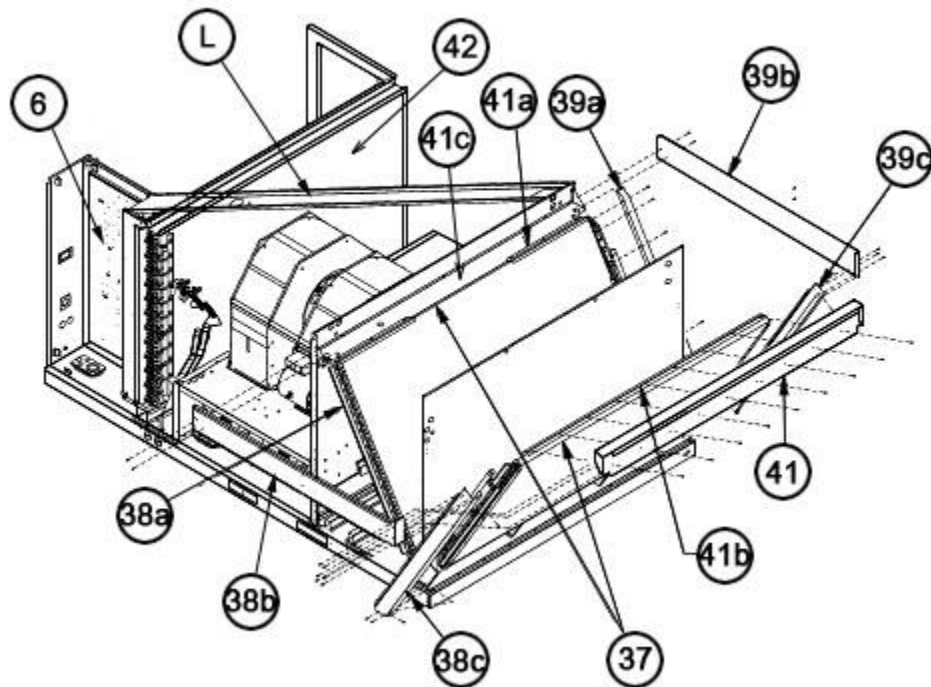

Interior - Coil 180-300

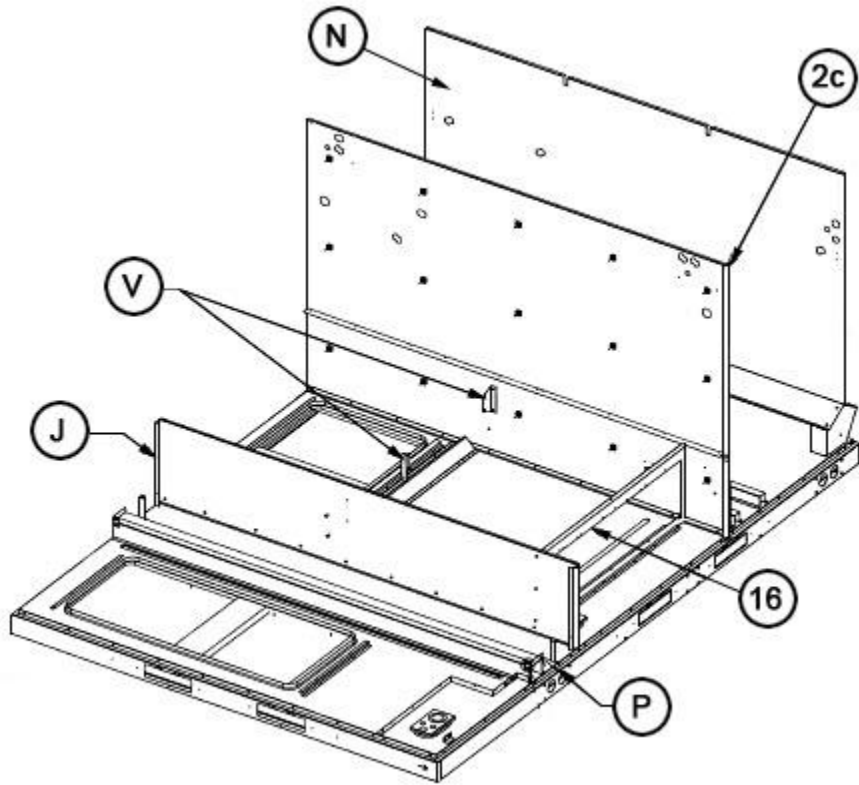

Heat Compartment 180-300

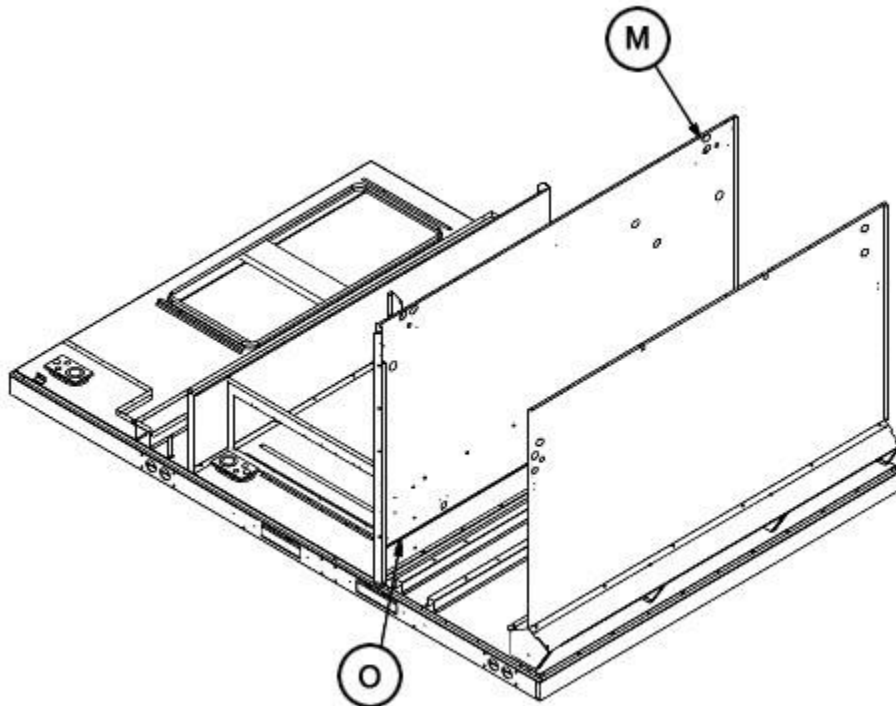

Condenser Bulkhead 180-300

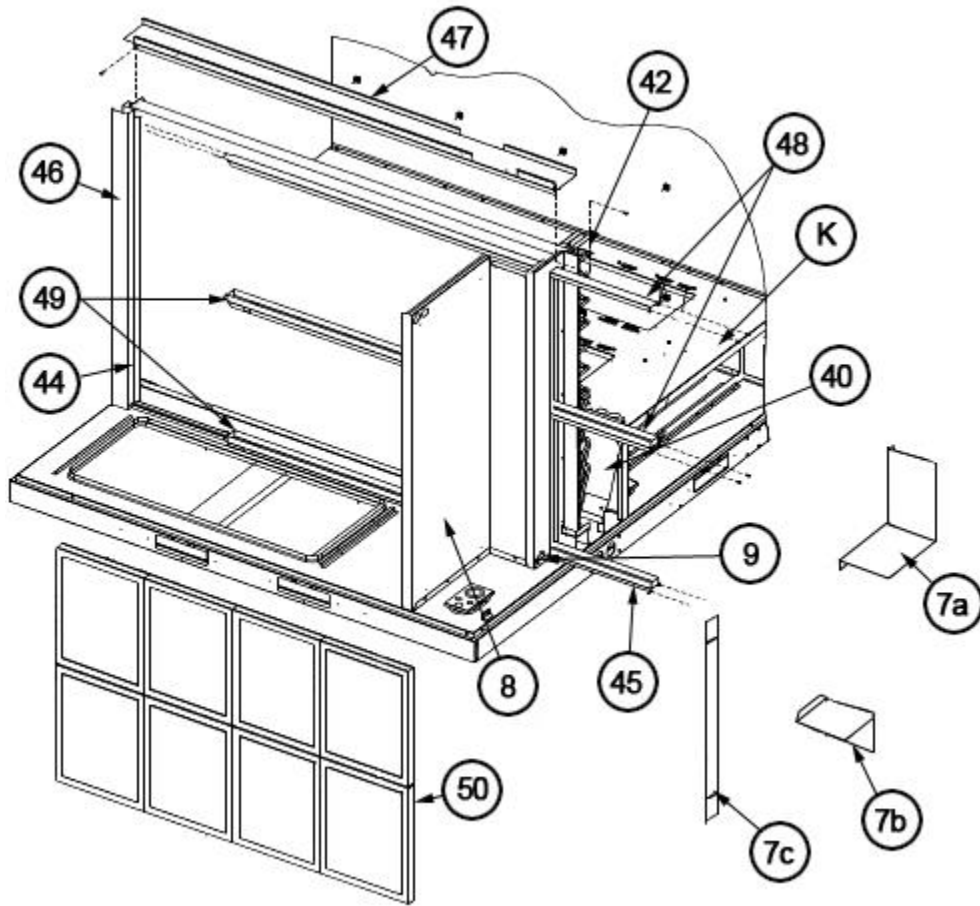

Filter Frame - Low Voltage Shields 180-300

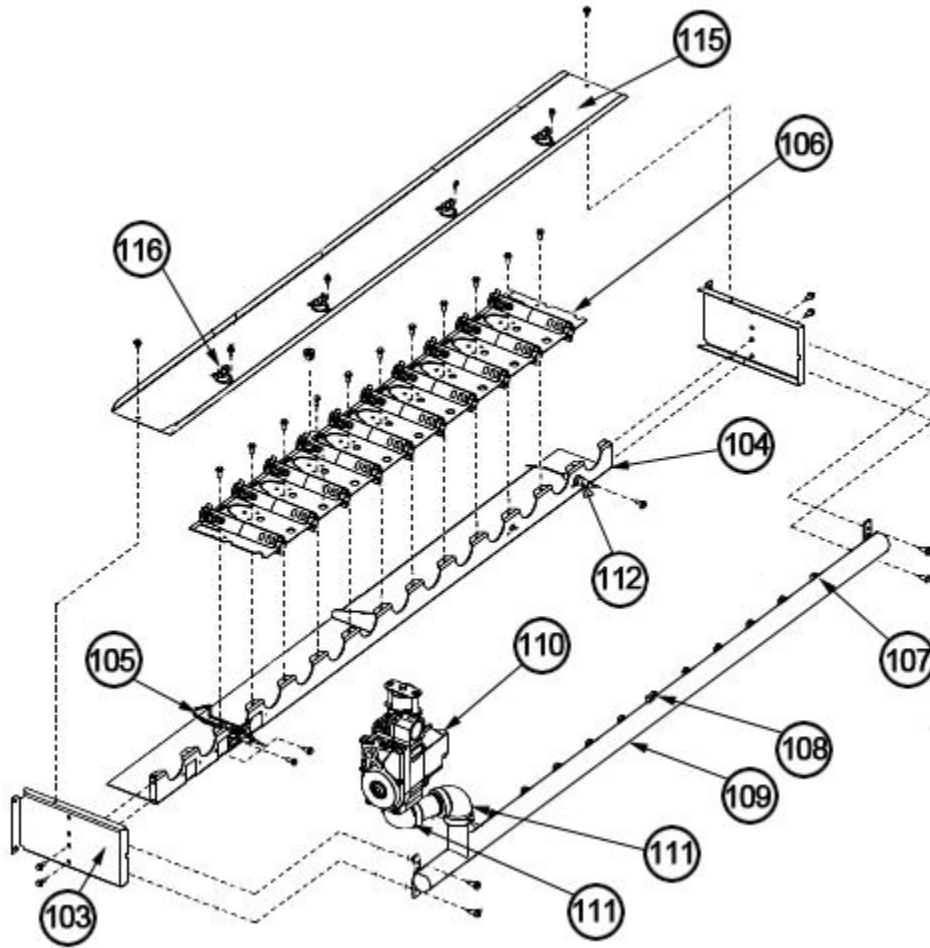

Burner Assembly 180-300

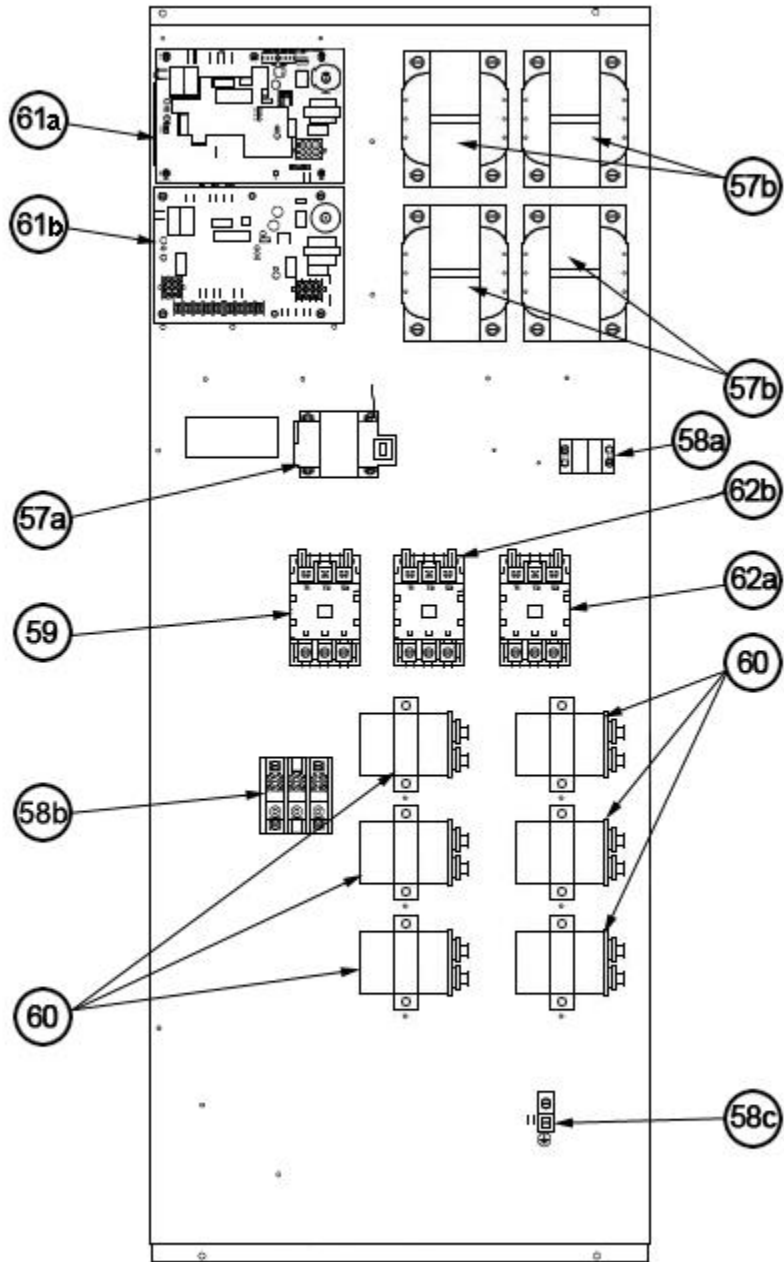

Control Box 180-300

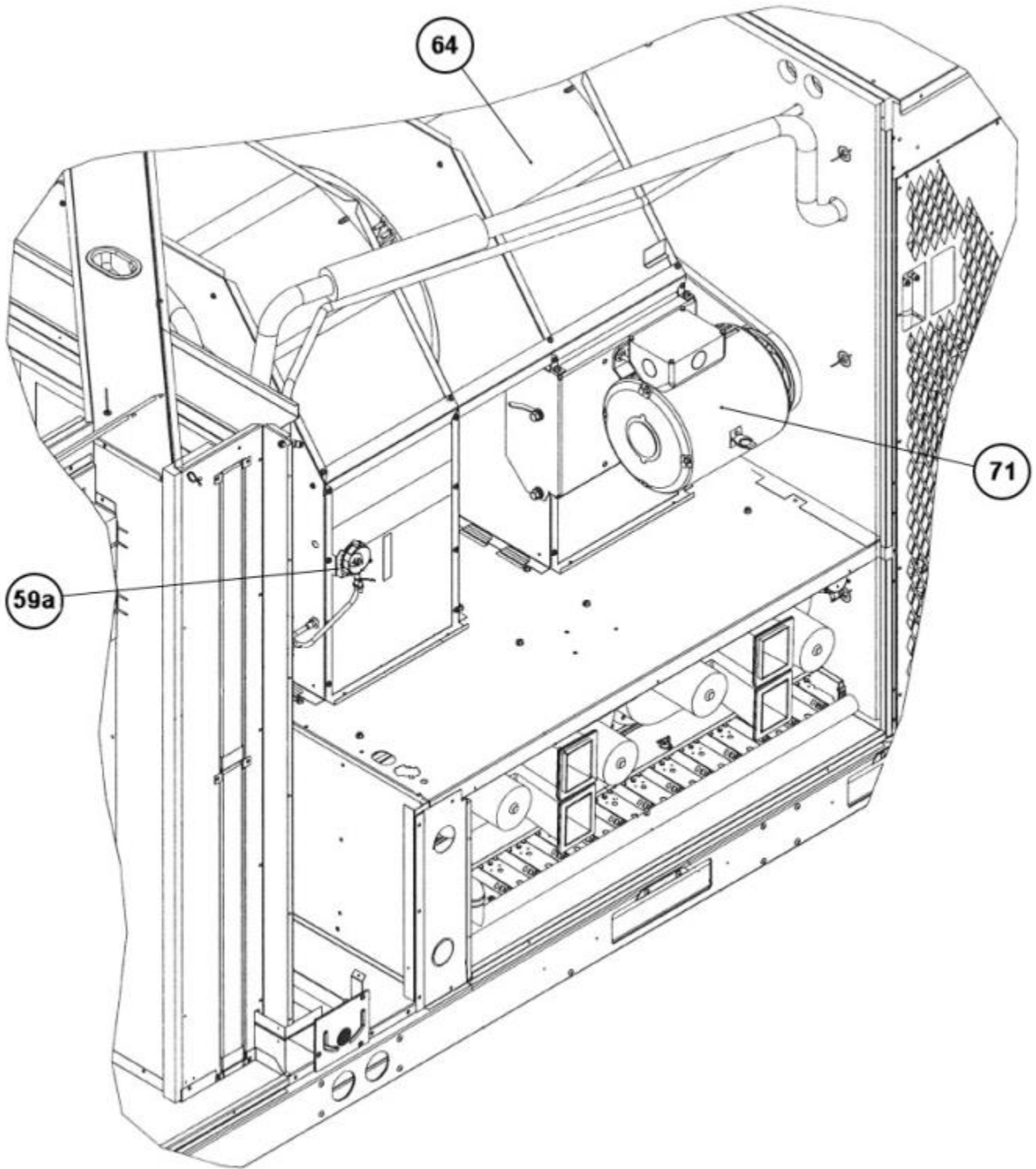

Blower Compartment View 180-300

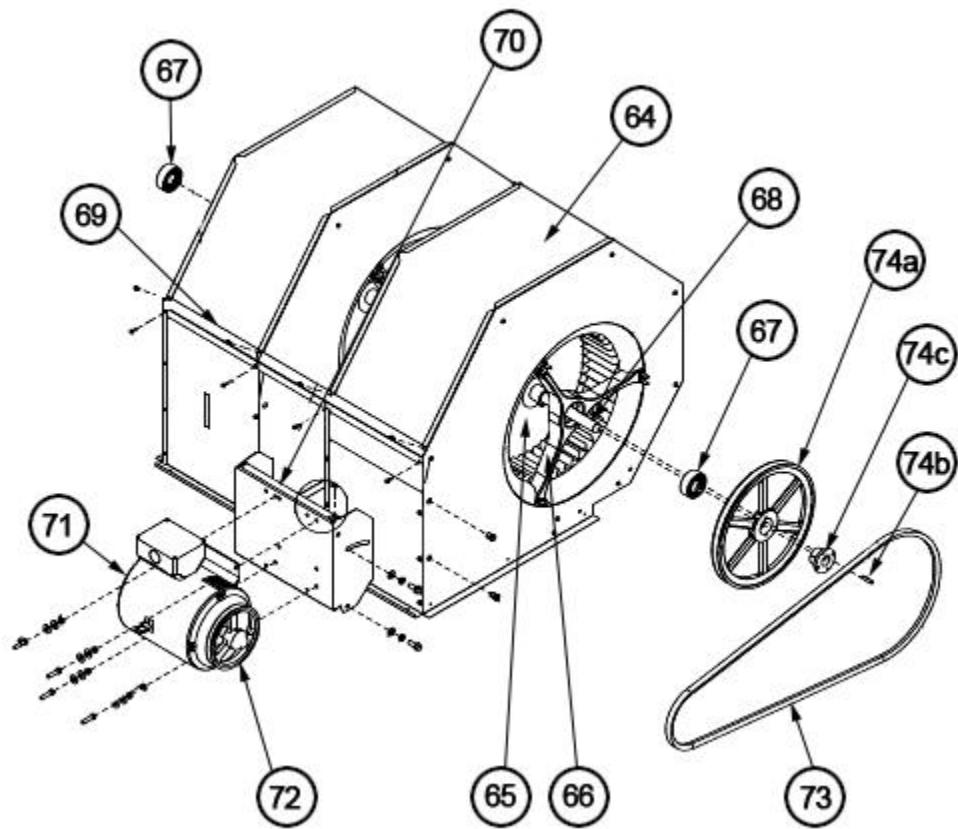

Blower Assembly 180-300

NOTES

Stk It is recommended that stock be maintained for this part.

N/A Not Applicable

- 1 Order the specified LP Conversion Kit.
- 2 Order Gas Valve for Natural Gas along with LP Conversion Kit.
- 3 Some units were shipped with a Low Pressure Control that is different from that listed. Use the Low Pressure Control specified for replacement.
- 4 The specified replacement pressure switch may have a different pressure setting than that originally supplied.
- 5 IFC rotated 90 degrees on 072-151 units produced after approximate date code F3512.
- 6 On approximate Date Code 0213, the wire screens were removed from the Gas Heat Door inlet hood openings. If replacing the door on a unit manufactured after this date, new Inlet Flue Hoods (AE-90745-04) should be ordered. The new inlet hoods incorporate louvers to prevent entry of debris into the combustion chamber.
- 7 Temperature Sensors are integral with the Wiring Harness and are not individually replacable.

DISCLAIMER: This document is intended to provide general replacement parts information to aid qualified service personnel in the repair of these models. The complete Model and Serial Number of the unit under repair should be specified when selecting and ordering replacement parts. Specifications and illustrations are subject to change without notice. Document 92-42800-RKNL-C supersedes all previous parts lists for these models. See <http://www.rheempartslists.net/92-42800-RKNL-C> for the latest revision of this document. The manufacturer assumes no obligation for errors or omissions. Service personnel must verify the proper and safe operation of equipment after the replacement of any original components.