

Air Cooled Condensing Unit Designed for Reznor Split Systems



**R-410A
Refrigerant
Only**

IMPORTANT:

Check, Test, and Startup **MUST** be followed, as documented in this manual. A completed Condenser Startup Form (page 41) may be required for validation of any warranty claims. The factory reserves the right to deny warranty without completed Condenser Startup Form.

This booklet includes operation, maintenance, and service information. Before beginning any procedure, carefully review the information, paying particular attention to the warnings. All installation procedures including handling of refrigerant must be in compliance with all codes and requirements of authorities having jurisdiction.

Installer should complete information on page 49.

Condenser Startup Form on page 48 should be completed on initial startup.

Owner should keep this booklet for future reference.

Table of Contents

1.0 General	3	8.0 Controls and Operation	24
1.1 Hazard Labels and Notices	3	8.1 Analog Control System	24
1.2 General Information	4	8.2 Digital Control System	24
1.3 Warranty	4	8.3 Other Compressor and Refrigerant	
1.4 Installation Codes	4	Controls	24
2.0 Location	4	8.3.1 High Pressure Cutoff	24
3.0 Receiving, Moving, and Uncrating	5	8.3.2 Low Pressure Cutoff	24
3.1 Receiving	5	8.3.3 Compressor Protection	24
3.2 Moving	5	8.3.4 Crankcase Heaters	24
3.3 Uncrating	5	9.0 Final Checks and Start-Up	25
4.0 Clearances and Dimensions	5	9.1 General Comments	25
4.1 Clearances	5	9.1.1 Checklist Prior to Start-up	25
4.2 Dimensions	6	9.2 Start-up	26
5.0 Mounting	7	9.2.1 Power Supply Voltage Phasing	26
5.1 Weights	7	9.2.2 Operating Sequence	27
5.2 Lifting	7	9.2.3 Refrigerant Charge	27
5.3 Mounting	7	9.2.3.1 <u>Check SUBCOOLING</u>	27
6.0 Mechanical	7	9.2.3.2 <u>Determine SUPERHEAT</u>	28
6.1 Refrigerant Piping	7	9.3 After Startup:	28
6.1.1 Location of Piping Connections at		10.0 Maintenance and Service	29
the Condensing Unit	7	10.1 General	29
6.1.2 Location of Piping Connections at		10.2 Maintenance Schedule	29
the Split System Evaporator Coil	8	10.3 Condenser Fan(s) Maintenance	30
6.1.3 Refrigerant Piping Guidelines		10.4 Condenser Coil Maintenance	30
(R-410A Refrigerant)	11	10.5 Compressor Maintenance and	
6.1.3.1 Type of Refrigerant Piping	11	Replacement	31
6.1.3.2 Refrigerant Piping Length		10.6 Troubleshooting Chart	37
and Size	11	10.7 Spare parts	39
6.1.3.3 Liquid Line Piping	13	Appendix	40
6.1.3.4 Suction Line Piping	15	IMPORTANT Reminders about R-410A	
6.1.3.5 Brazing Connections	16	Refrigerant and POE Oil	40
6.1.3.6 Piping Support and Insulation	16	Model MASA Technical Information	41
6.2 Leak Test the Refrigerant Circuits	17	Performance tables	42
6.2.1 Leak Test the Condensing Unit	17	Pressure/Temperature Chart for R-410A Refrigerant	
6.2.2 Leak Test the Field-Installed Piping	17	for Checking Subcooling	
6.3 Evacuate the Circuits	17	and Superheat	48
6.4 R-410A Refrigerant Charge	18	Condenser startup form	49
7.0 Electrical and Wiring	19	INSTALLER MUST COMPLETE INFORMATION	
7.1 General	19	FORM	50
7.2 Supply Wiring	19		

1.0 GENERAL

1.1 Hazard Labels and Notices

There are warning labels on the condensing unit and throughout this manual. For your safety, read the definitions below and comply with all boxes labeled CAUTION, WARNING, and DANGER during installation, operation, maintenance, and service of this system.

Definitions of Hazard Intensity Levels in this Manual

HAZARD INTENSITY LEVELS

DANGER: Failure to comply will result in severe personal injury or death and/or property damage.

WARNING: Failure to comply could result in severe personal injury or death and/or property damage.

CAUTION: Failure to comply could result in minor personal injury and/or property damage.

WARNING

Improper installation, adjustment, alteration, service, or maintenance can cause property damage, personal injury, or death. A qualified installer or service agency must perform installation and service.

DANGER

This condensing unit is designed to use R-410A high pressure refrigerant only. Hazards exist that could result in personal injury or death. Installation, maintenance, and service should only be performed by an HVAC technician qualified in R-410A refrigerant and using proper tools and equipment. Due to much higher pressure of R-410A refrigerant, DO NOT USE service equipment or tools designed for R22 or R-407C refrigerant.

DANGER

Never use oxygen to pressurize a refrigeration system. Oxygen can explode on contact with oil and result in personal injury or death. When using high pressure gas such as nitrogen for pressurizing a refrigeration system, ALWAYS USE A PRESSURE REGULATOR that can control the pressure down to 0,1 bar.

SAFETY WARNINGS

For your safety, wear eye protection, gloves, and protective clothing when handling R-410A refrigerant or POE oil and when brazing. Have a fire extinguisher nearby when brazing.

WARNING

Before installing or servicing, always turn off the main power to the system and install a lock out on the disconnect switch.

CAUTION

Do not leave system open to the atmosphere any longer than minimum required for installation. Exposure for more than five minutes may contaminate the system. POE oil in the compressors is extremely susceptible to moisture absorption. Always keep ends of tubing sealed during installation.

1.2 General Information

This booklet includes operation, maintenance, and service information. Before beginning any procedure, carefully review the information, paying particular attention to the warnings. All installations must be in compliance with all codes and requirements of authorities having jurisdiction.

A Model MASA outdoor condensing unit operates on R-410A refrigerant and has two independent refrigeration circuits configured in an approximate 1/3-2/3 arrangement. The Model MASA condensing unit is designed for use with a Reznor PREEVA air handler unit with a 1/3-2/3 two-circuit cooling coil. PREEVA indoor Model is SDH; outdoor Model is RDH.

The Model MASA condensing unit may also be matched to a field-supplied 1/3-2/3 two-circuit evaporator coil. An air handler used with a Model MASA condensing unit must be properly matched; the evaporator coil must have freeze protection and must be equipped with properly sized thermal expansion valves.

CAUTION

The condensing unit must be matched to an approximate 1/3-2/3 two-circuit, R-410A refrigerant coil with properly sized thermal expansion valves. Failure to properly match and/or equip the split system components will prevent the system from operating correctly and will void the manufacturer's warranty. See Hazard Levels, page 3.

1.3 Installation Codes

These units must be in accordance with EN 378-4 as appropriate plus all local building codes.

2.0 LOCATION

Model MASA condensing unit must be mounted outdoors on a level surface. The supporting structure must be able to support the operating weight of the unit and maintain a level plane during continued operation. Water should drain away from the unit. Location must comply with free space clearances for unrestricted airflow (See Paragraph 4.1) and the refrigerant piping requirements (See Paragraph 6.1.3). Avoid facing condenser coils into the prevailing wind.

3.0 RECEIVING MOVING/UNCRATING

3.1 Receiving

The unit was test operated and inspected at the factory prior to crating and was in proper operating condition.

If the heater has incurred damage in shipment, document the damage with the transport company and contact your supplier.

3.2 Moving

The heavy gauge base of the condensing unit has forklift openings in both sides. To move a unit, use a forklift with forks that have a minimum length of 610mm.

3.3 Uncrating

Immediately upon uncrating, check the rating plate to verify that the unit is suitable for the installation site. This condensing unit is designed for R-410A refrigerant only; verify that the split system air handler is for use with R-410A refrigerant.

Shipped-Separate Items

Before beginning installation, be sure that all shipped-separate options ordered are available at the site. Shipped-separate options could have been ordered with the condensing unit or the matching PREEVA air handler.

NOTE: Two liquid line filter driers are shipped loose with the condensing unit for field installation

4.0 CLEARANCES & DIMENSIONS

4.1 Clearances

The condensing unit must have unrestricted airflow on the coil side and above the unit. A service clearance is required on the control side of the cabinet.

Figure 1 - minimum clearances (top view)

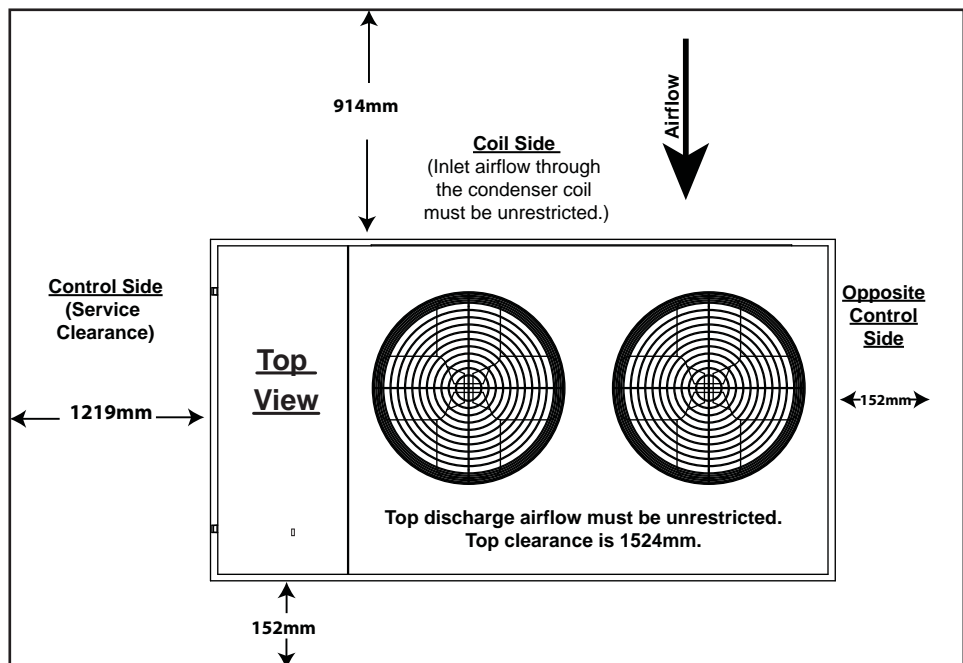

4.2 Dimensions

Figure 2a - model MASA 15 and 22 dimensions

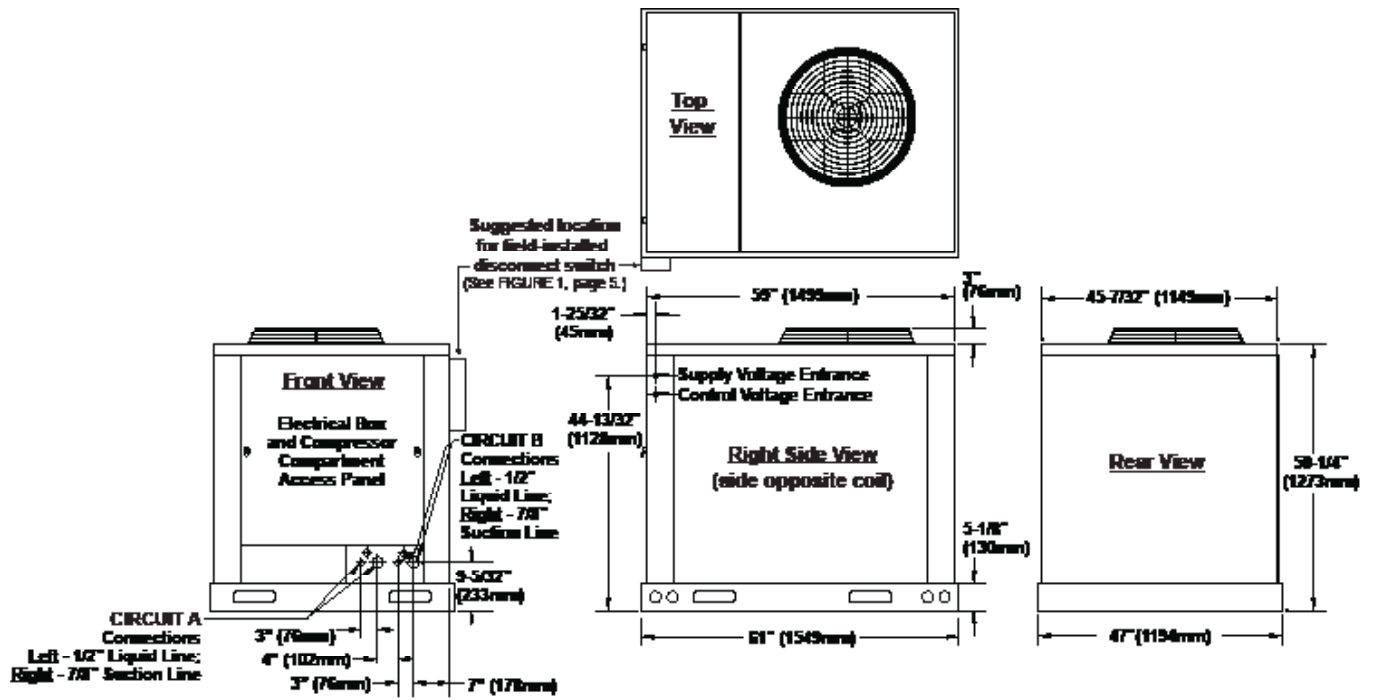
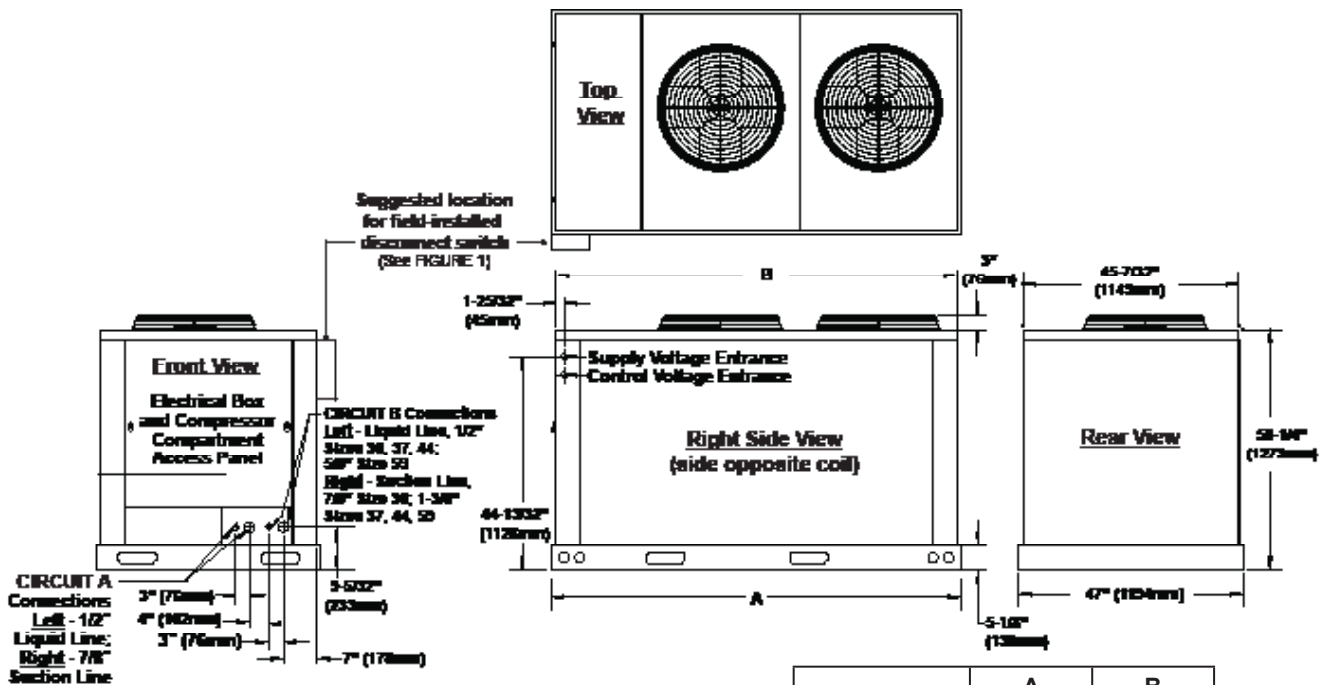

Figure 2b - model MASA 30, 37, 44, 59 dimensions



MASA Sizes	A	B
	Dimensions (mm)	
30, 37	2184	2134
44, 59	2794	2743

5.0 MOUNTING

5.1 Weights

Before installing, check the supporting structure to be sure that it has sufficient load-bearing capacity to support the operating weight of the unit. Mounting is the responsibility of the installer.

Table 1

Approximate Operating Weight of Condensing Unit

MASA Size	15	22	30	37	44	59
kg	200	209	287	317	340	350

5.2 Lifting

The heavy gauge base of the condensing unit has fork lift holes and a pair of lifting holes on each corner for rigging. If lifting with a forklift, forks must have a minimum length of 610mm. If attaching rigging, insert a clevis in each set of holes for the rigging **and lift using spreader bars. Lift the unit straight up with vertical force.**

Test lift the unit to be sure that it is secure and then lift slowly following safe lifting procedures. Lifting and rigging are the responsibility of the installer.

5.3 Mounting

Condensing unit may be set directly on a roof or slab. Unit must be level. Be sure to comply with clearances in **FIGURE 1**.

6.0 MECHANICAL

6.1 Refrigerant piping

6.1.1 Location of Piping Connections at the Condensing Unit

Remove the control compartment door panel. Locate the refrigerant connections in the lower right corner. See **FIGURE 3**. Each circuit is shipped with a nitrogen charge and has a shutoff valve. Do not open the valves until after the lines are connected and the condenser circuits are leak tested.

The entrances for the two main refrigerant circuits are identified as Circuit A and Circuit B (See **FIGURE 3**). Circuit A is the smaller (approximate 33%) condenser circuit; Circuit B is the larger (approximate 67%) circuit. Also indicated, are the entrances for optional hot gas bypass circuits. If the condensing unit is equipped with a hot gas bypass on only one circuit, only one entrance will be used. If equipped with a hot gas bypass on both circuits, both entrances will be used. **When connecting refrigerant lines to the condensing unit and the air handler, it is very important to make all connections so that each individual circuit is maintained.**

CAUTION

Do not remove seal caps from refrigerant connections or open the service valves until ready to make permanent connection. Exposure to the atmosphere for longer than five minutes may allow moisture and dirt to contaminate the system. See Hazard Levels, page 3.

Figure 3
Condensing
Unit
Refrigerant
Piping

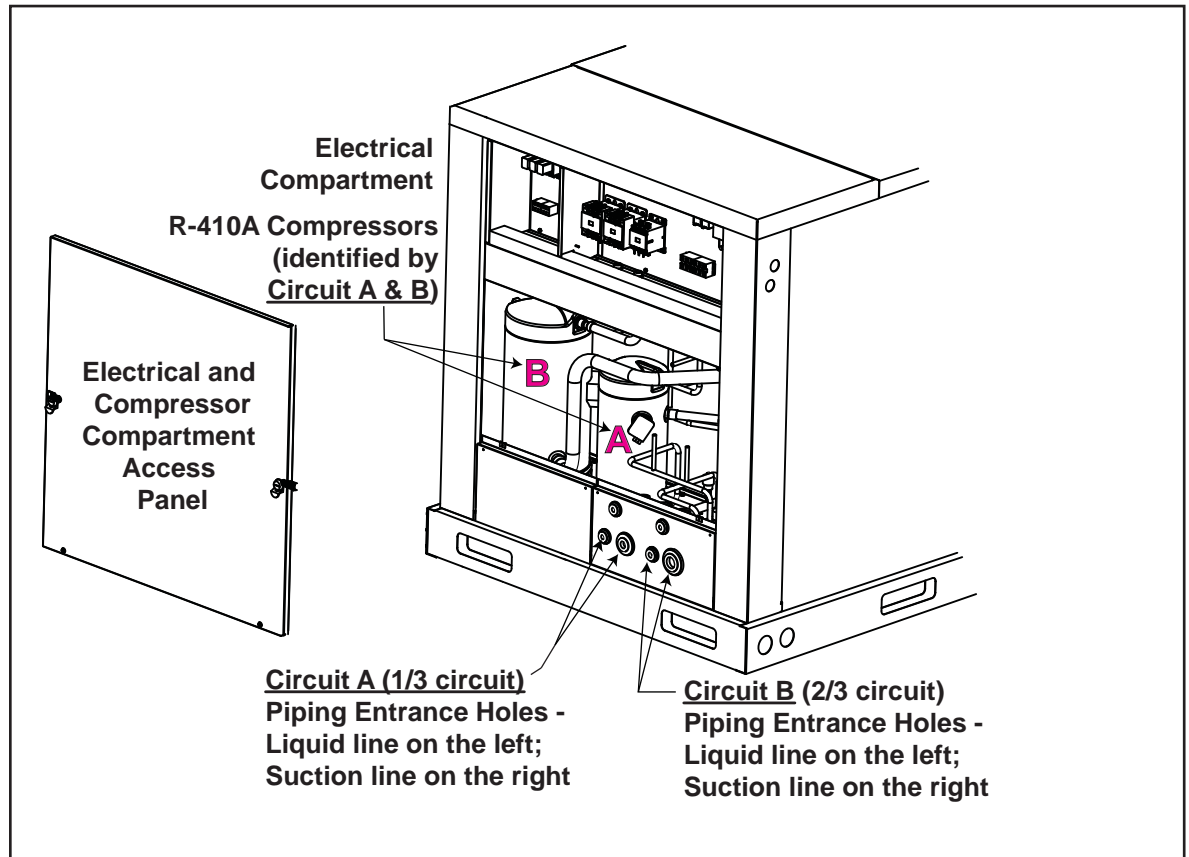

6.1.2 Location of Piping Connections at the Split System Evaporator Coil

It is important to identify the Circuit A and Circuit B connections at the evaporator coil before running the refrigerant lines.

Circuit A on the condenser (**FIGURE 3**) is the smaller (33%) circuit and should be connected to the 33% circuit of the evaporator coil. Circuit B on the condenser (**FIGURE 3**) is the larger (67%) circuit and should be connected to the 67% circuit of the evaporator coil.

On the evaporator coil, identify the liquid line connection at the distributor for the smaller circuit (Circuit A). Force nitrogen into the Circuit A connection and check which suction line connection corresponds to it. If the suction line connection is not identified, mark it as Circuit A. For verification, repeat the process with the larger circuit and mark the suction line connection as Circuit B.

Refer to **FIGURE 4A** or **4B** for illustration of a split system refrigerant piping system connecting a MASA condensing unit to a PREEVA evaporator coil. In **FIGURE 4A**, the condensing unit is higher than the evaporator coil. In **FIGURE 4B**, the condensing unit is lower than the evaporator coil.

Figure 4A - Refrigerant Piping on a PREEVA Split System with the Condensing Unit Installed at a Higher Level than the Air Handler Unit

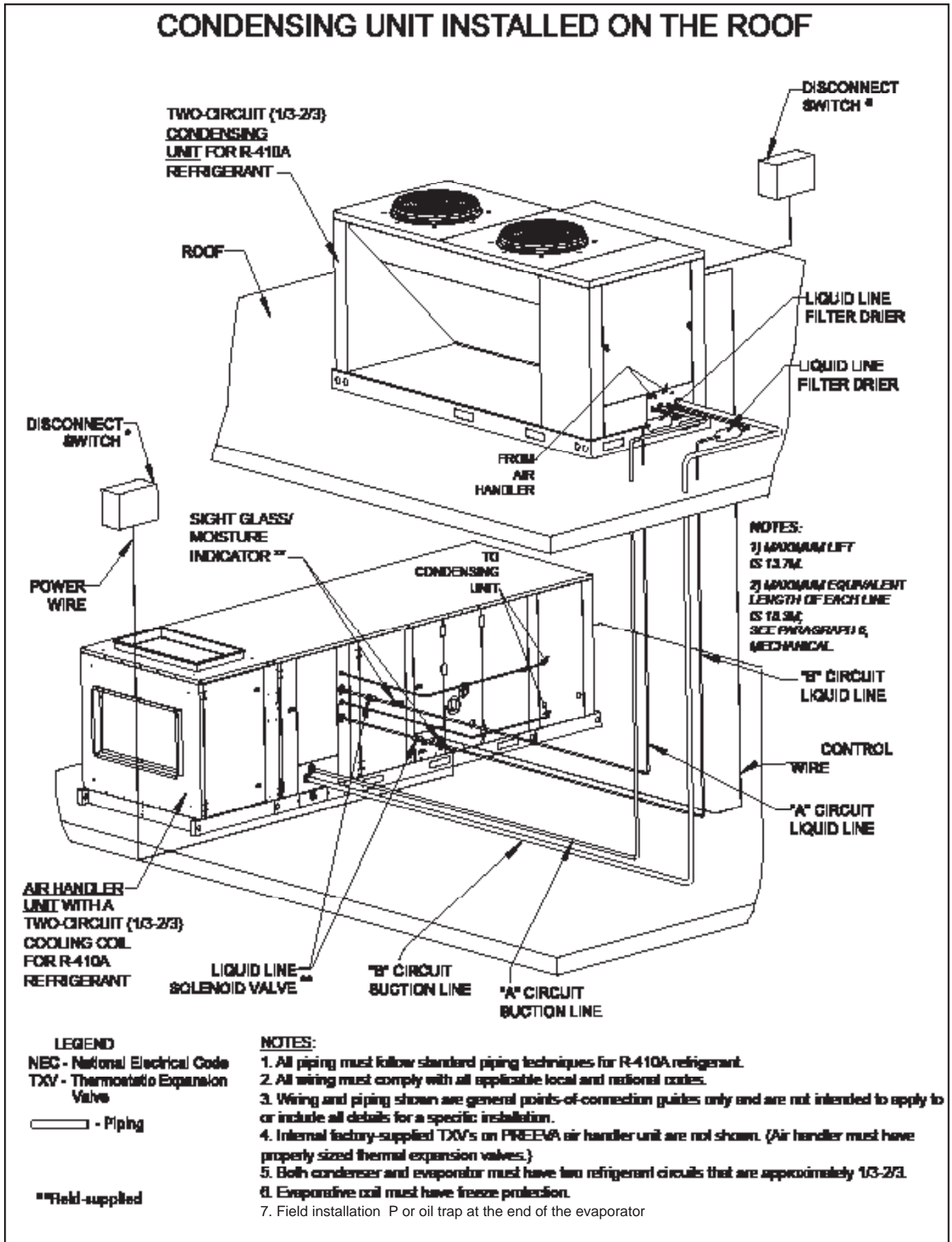
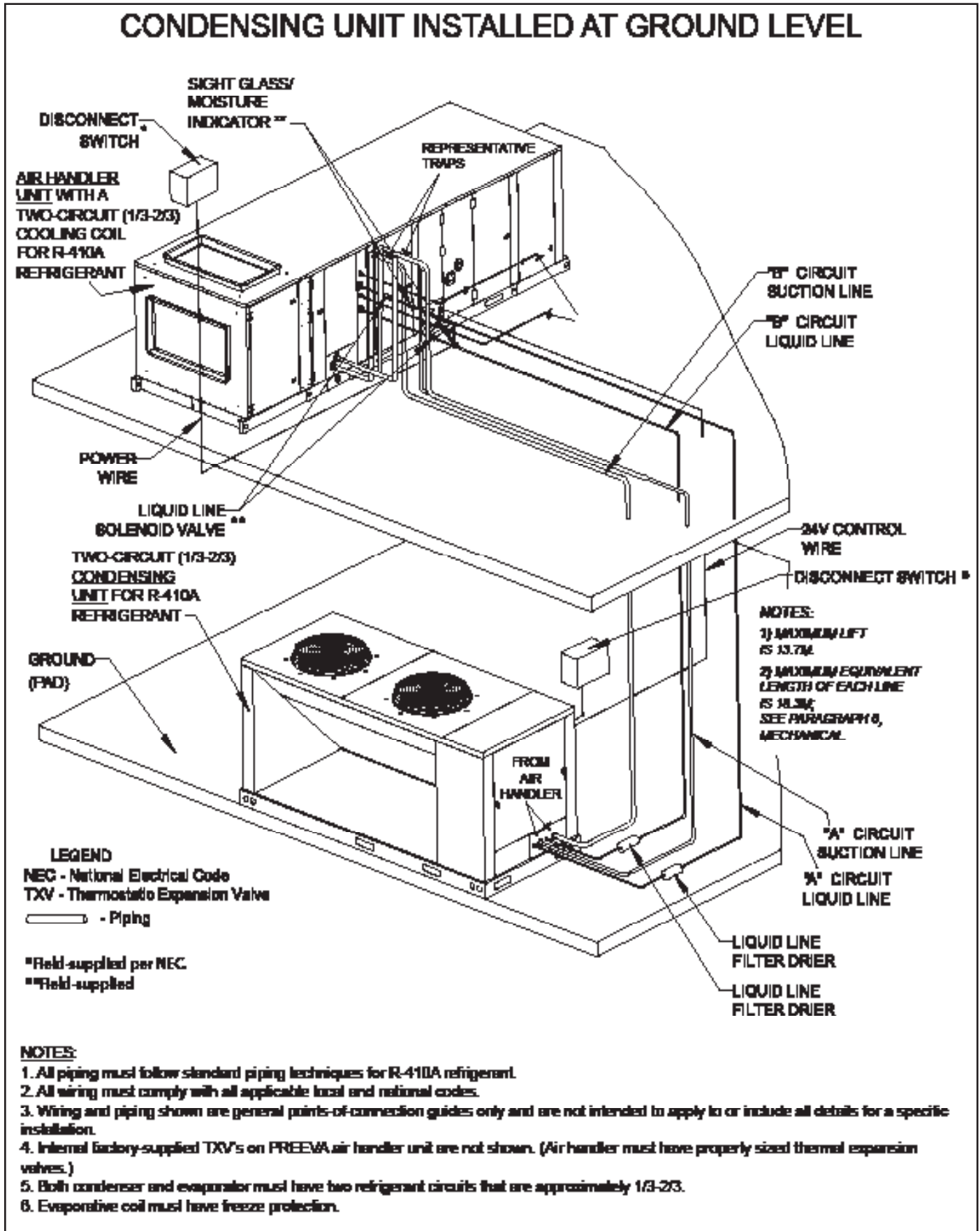

Figure 4B - Refrigerant Piping on a PREEVA Split System with the Condensing Unit Installed at a Lower Level than the Air Handler Unit



6.1.3 Refrigerant Piping Guidelines (R-410A Refrigerant)

The information in this section is a guideline and is not intended to provide all of the instructions needed for designing and installing the R-410A refrigerant lines. The installer is responsible for designing the refrigerant connecting system and for complying with standard refrigerant piping procedures.

Read all information in Section 6.1.3 before beginning installation of refrigerant piping. In addition to the information in the following paragraphs, these general requirements apply.

- **IMPORTANT:** Do not bury refrigeration lines.
- Pitch refrigerant lines in the direction of flow at approximately 12mm per 3m.
- To prevent possible noise or line vibration, isolate refrigerant lines from building structure and ductwork.
- Use long radius for all 90° bends.
- Isolate suction and liquid lines from each other and from the unit cabinet.

CAUTION

Do not leave system open to the atmosphere any longer than minimum time required for installation. POE oil in the compressors is extremely susceptible to moisture absorption. Keep ends of tubing sealed during installation. See Hazard Levels, page 3.

6.1.3.1 Type of Refrigerant Piping

Refrigerant piping is field supplied. Use only clean, dehydrated refrigeration grade Type L scheduled or ACR Hard Drawn (ASTM B 280) copper tubing. Size of refrigerant line segments depends on the condensing unit size and the length and configuration of the lines. Do not determine the size of the piping by the size of the connections at the condenser or evaporator; follow the line sizing instructions in Section 6.1.3.2 below.

6.1.3.2 Refrigerant Piping Length and Size

Design the refrigerant circuit for a minimum pressure loss by keeping the actual length to a minimum, with a minimum number of bends and fittings, and with a minimum amount of line exposed to the outdoors. Excessive suction line pressure drop will result in decreased thermal efficiency and increased power requirements. Excessive liquid line pressure drop can cause the refrigerant to flash resulting in faulty expansion valve operation. Typically, each segment of the refrigerant line should be sized for pressure loss of 1,1°C or less.

Lift must also be considered when determining location and piping length. Maximum lift of the refrigerant circuit is 13.7m.

Tubing size is determined separately for each of the four segments of the refrigerant piping - Circuit A liquid line; Circuit A suction line; Circuit B liquid line; and Circuit B suction line. The size of the tubing required for each segment is determined by its equivalent length. The equivalent length is the actual length of the line segment plus any fittings or accessories.

If accessories (see Paragraphs 6.1.3.3 and 6.1.3.4 for required accessories) have equivalent lengths provided by the manufacturer, use that information. If equivalent length is not provided and for fittings, use the equivalent lengths in **TABLE 2**.

Table 2 - Fitting Pressure Loss in Equivalent Length of Straight Copper Tubing

NOTE: Liquid line filter driers provided have 1/2" connections. Add equivalent length for filter driers plus, if liquid line is not 1/2", add equivalent for fittings.

Equivalent Length of Fittings and Accessories													
Line Size OD	Globe / Solenoid Valve	Angle / Check Valve	90° SR Elbow	90° LR Elbow	45° Elbow	Tee Line / Sight Glass	Tee Branch	(1) Coupling to Enlarge OD by			(2) Coupling to Reduce OD by		
								1/4"	1/2"	3/4"	1/4"	1/2"	3/4"
								Equivalent Length (in Meters of Pipe)					
1/2"	2,7	1,5	0,43	0,27	0,12	0,18	0,61	0,43	0,24	0,09	0,21	0,15	0,09
5/8"	3,7	1,8	0,45	0,30	0,15	0,24	0,76	0,55	0,34	0,12	0,24	0,21	0,12
3/4"	4,3	2,1	0,58	0,40	0,18	0,27	0,91	0,76	0,46	0,15	0,37	0,30	0,15
7/8"	4,6	2,4	0,70	0,46	0,21	0,30	1,07	0,98	0,61	0,21	0,49	0,37	0,21
1-1/8"	6,7	3,7	0,82	0,55	0,27	0,46	1,37	1,43	0,91	0,30	0,70	0,55	0,30
1-3/8"	8,5	4,6	1,10	0,73	0,37	0,55	1,83	1,77	1,10	0,88	0,88	0,67	0,37



Use the worksheet on page 13, and the information in **TABLE 2** and **TABLE 3** to determine the line segment and circuit equivalent lengths and the size of tubing required for each line segment.

IF AN APPLICATION REQUIRES MORE THAN 18.3M OF EQUIVALENT LENGTH OF TUBING (LIQUID LINE OR SUCTION LINE) BETWEEN THE CONDENSER AND THE AIR HANDLER, CONTACT REZNOR FOR APPROVAL.

Table 3 - Recommended Size of Refrigerant Piping for each Segment determined by the Equivalent Length

*Minimum Recommended Refrigerant Piping Size							
MASA Model	Circuit	Suction Line Tubing Size (OD)			Liquid Line Tubing Size (OD)		
		**Equivalent Length of the Suction Line (m)			**Equivalent Length of the Liquid Line (m)		
		up to 7m	>7 to 15m (> 7.6 to 15.2M)	>15m (> 15.2 to 18.3M)	up to 7m	>7 to 15m (> 7.6 to 15.2M)	>15 to 18m (> 15.2 to 18.3M)
15	A	5/8	5/8	5/8	3/8	3/8	3/8
	B	3/4	3/4	3/4	1/2	1/2	1/2
22	A	5/8	3/4	3/4	1/2	1/2	1/2
	B	7/8	7/8	1 1/8	1/2	1/2	1/2
30	A	3/4	3/4	3/4	1/2	1/2	1/2
	B	7/8	1 1/8	1 1/8	1/2	1/2	1/2
37	A	3/4	3/4	7/8	1/2	1/2	1/2
	B	1 1/8	1 1/8	1 3/8	1/2	5/8	5/8
44	A	7/8	7/8	1 1/8	1/2	1/2	1/2
	B	1 1/8	1 1/8	1 1/8	1/2	5/8	5/8
59	A	7/8	1 1/8	1 1/8	1/2	1/2	1/2
	B	1 1/8	1 3/8	1 3/8	5/8	5/8	5/8

*Based on copper tubing type L; a 1,1°C loss; and a maximum of 18°C suction line (return gas) temperature and liquid line temperature of 41°C.

**Equivalent Line Segment Length = length of field-installed tubing in line segment plus equivalent length of all field-installed fittings and accessories in line segment. For both liquid line and suction line segments, maximum recommended equivalent length is 18m.

Worksheet for calculating the equivalent length of each of the four line segments

Circuit (field-installed Liquid Line Segment and Suction Line Segment)	CIRCUIT A (1/3 Circuit)				CIRCUIT B (2/3 Circuit)				
	Liquid Line		Suction Line		Liquid Line		Suction Line		
Line Segment (field-installed refrigerant tubing)	Tubing Size _____		Tubing Size _____		Tubing Size _____		Tubing Size _____		
Equivalent Lengths of All Accessories and Fittings in the Line Segment	Component	Length	Component	Length	Component	Length	Component	Length	
Subtotal of Equivalent Lengths of Accessories/Fittings									
<i>Plus</i> Actual Length of Line Segment									
<i>Equals</i> Equivalent Line Segment Length									
IMPORTANT Note: Recommended maximum total equivalent line length between the condenser and evaporator coil is 18.3. For line segments longer than 18.3m equivalent length, consult Reznor for approval.									

6.1.3.3 Liquid Line Piping

Design the liquid lines (a line for each circuit from the condenser to the thermal expansion valve on the appropriate distributor at the evaporator coil) so that the pressure drop in the liquid refrigerant will not be greater than that corresponding to an approximate 0,5°C-1,1°C of subcooling. Pressure loss of 0,34 bar results in a 0,5°C loss of subcooling temperature with R-410A refrigerant. The total loss is the pressure drop loss through the piping and fittings plus any additional for lift or accessories (shutoff valve, filter, etc). Pressure loss due to lift is approximately 0,1 bar/m.

Each liquid line requires field installation of one of the filter driers supplied with the unit (see instructions below and **FIGURE 4A or 4B**). Filter driers are sized for each circuit; see **TABLE 4** to match the filter drier with the circuit. Also, it is highly recommended that each liquid line include a field-supplied solenoid valve and a sight glass with a moisture indicator. (NOTE: Do not rely on the sight glass for determining amount of refrigerant charge; see Paragraph 6.4 and subcooling and superheat checks in Paragraph 9.2.3 for determining refrigerant charge. A sight glass with a moisture indicator is important because moisture is very detrimental to an R-410A refrigerant circuit.) Install the recommended field-supplied sight glass with moisture indicator downstream of the filter drier and upstream of the thermal expansion valve.

Liquid Line Filter Driers - Two liquid line filter driers are shipped loose for field installation. Match the filter drier to Circuit A or Circuit B as listed in **TABLE 4**.

Follow the filter drier manufacturer's instructions and install the correct filter drier in each liquid line close to the condensing unit. The arrow on the drier must be pointing toward the evaporator coil. If liquid line piping is not the same size, use a field-supplied fitting. Protect the filter drier from excessive heat when brazing.

Table 4 - Two Liquid Line Filter Driers are Shipped Loose in the Condensing Unit

MASA	Refrigerant Circuit	R410A Liquid Line Filter Driers Shipped in the Condensing Unit for Field Installation		
Size	Circuit	Model	Reznor P/N	Connection Size
15	A	C-084-S	03 401US 177378	1/2
	B	C-164-S	03 401US 177379	1/2
22	A	C-084-S	03 401US 177378	1/2
	B	C-304-S	03 401US 177379	1/2
30	A	C-164-S	03 401US 177379	1/2
	B	C-304-S	03 401US 216408	1/2
37	A	C-164-S	03 401US 177379	1/2
	B	C-304-S	03 401US 216408	1/2
44	A	C-304-S	03 401US 177379	1/2
	B	C-414-S	03 401US 216409	1/2
59	A	C-304-S	03 401US 216408	1/2
	B	C-415-S	03 401US 216410	5/8

Thermal Expansion Valves - The thermal expansion valves are field-supplied or ordered as options with the air handler. **The valves must be designed for R-410A refrigerant and sized correctly for each circuit.**

CAUTION

The thermal expansion valves must be sized to match the circuit. Failure to properly size the thermal expansion valves will prevent the system from operating properly and will void the manufacturer's warranty. See Hazard Levels, page 3.

If the thermal expansion valves are not pre-installed on the air handler, install the outlet of the valve to the distributor connection on the evaporator coil. (Exception **NOTE**: If there is an optional hot gas bypass line in the circuit, it must be allowed to connect directly into the distributor downstream of the thermal expansion valve; see Paragraph 6.1.3.6.)

Thermal expansion valves are sized for the capacity of the circuit so be careful to match the valve to the correct circuit. Always wet wrap the valve body when brazing, but do not allow moisture to enter the tubing. Braze with the flame pointed away from the valve. Follow the instructions supplied from the valve manufacturer.

After the refrigerant lines are installed and before start-up, extend the bulb from the valve in Circuit A to the Circuit A suction line. Extend the bulb from the Circuit B valve to the Circuit B suction line. Comply with the valve manufacturer's instructions on bulb placement. General recommendations are listed below.

- Verify that the suction line is the correct circuit.
- Place bulb on suction line as close to the evaporator coil outlet as possible.
- Place the bulb on a straight horizontal section of suction line (if bulb must be vertical, line must be descending).

- Never place bulb in a trap or downstream of a trap.
- Position bulb as shown in **FIGURE 5**.
- Bulb must have 100% contact with tubing.
- Secure the bulb tightly.
- Cover bulb with waterproof insulation.

Figure 5 - Position of the Thermal Expansion Valve Bulb on the Suction Line

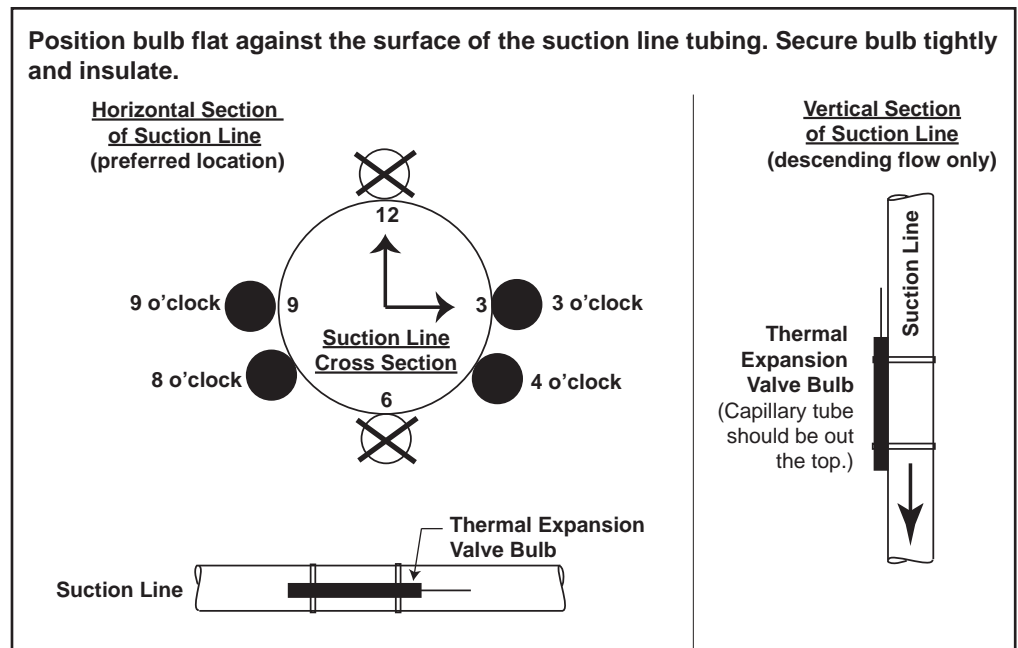

6.1.3.4 Suction Line Piping

The suction lines (lines carrying refrigerant vapor from the evaporator to the compressor) should be designed to provide minimum pressure drop and to return oil to the compressor under all load conditions. A suction line is normally sized to have a pressure drop no greater than an approximate 1,1°C of superheat.

Design and installation of the suction lines are critical to efficient operation and compressor life. Suction lines must be insulated and pitched in direction of flow. To ensure oil return, refrigerant velocity in vertical lines should be at least 7,7m/s and at least 3,8m/s in horizontal lines.

If the evaporator coil is above the condensing unit, a trap is required in the suction line as it leaves the evaporator. The top of the trap must be higher than the top of the evaporator. P- or oiltrap is every 3 meters required when condensing unit is above the evaporator.

Isolate the liquid lines from the suction lines. Insulate the entire length of each suction line.

6.1.3.5 Brazing Connections

CAUTION

Do not leave system open to the atmosphere any longer than minimum required for installation. Exposure for more than five minutes may contaminate the system. POE oil in the compressors is extremely susceptible to moisture absorption. Always keep ends of tubing sealed during installation. See Hazard Levels, page 3.

Brazing materials must be able to withstand the high pressure of R-410A refrigerant. A high temperature, silver phosphate type brazing with 5% or greater alloy is recommended.

To prevent oxidation, purge tubing with 0,2 bar of regulated dry nitrogen while it is being brazed. Before brazing connections, check the condenser unit for leaks (See Paragraph 6.2.1). After the unit has been properly leak tested, the nitrogen remaining in the circuit can be used as part of the purge while brazing. Open the service valve as needed to release the nitrogen. **Do not allow moisture to enter the system.**

The installer is responsible for brazing and for complying with appropriate standard refrigerant piping procedures.

CAUTION

All brazing should be done using a 2 to 3 psig dry nitrogen purge flowing through the pipe being brazed. See Hazard Levels, page 3.

CAUTION

Do not open the service valves until after the condenser unit circuits are leak tested (See Paragraph 6.2.1.) See Hazard Levels, page 3.

CAUTION

When brazing, protect all painted surfaces and components from excessive heat. Wet wrap all valves but do not allow moisture to enter the tubing. See Hazard Levels, page 3.

6.1.3.6 Piping Support and Insulation

Comply with piping support spacing requirements in **TABLE 5**.

Insulate the entire length of each suction line and optional hot gas bypass line(s). Insulate any portion of the liquid line that is subject to extreme temperature.

To prevent vibration noise, isolate all piping from the building structure or ductwork.

Table 5 - Maximum Spacing between Pipe Supports

Maximum Spacing Between Pipe Supports for Copper Tubing				
Nominal Diameter (OD)	5/8"	7/8"	1-1/8"	1-3/8"
Maximum Span	1.5m	1,8m	2,1m	2,4m

6.2 Leak & Pressure Test of the Refrigerant Circuits

6.2.1 Leak Test the Condensing Unit

The condensing unit is shipped with a 3,4 bar nitrogen holding charge in each circuit. Install gauges to assure that the condensing unit sections of Circuit A are pressurized. If circuit is not pressurized, the nitrogen has escaped. Recharge with dry nitrogen to 10,3bar. (Maximum test pressure is 31 bar) Use soap bubbles or other leak-detecting method. Repair as needed to ensure a leak-free circuit in the condensing unit. Repeat with Circuit B.

NOTE: The nitrogen charge in the condensing unit circuits may be used during the brazing process as part of the purge. See Paragraph 6.1.3.6.

6.2.2 Leak Test the Field-Installed Piping

Pressurize one of the circuits with dry nitrogen to 10,3 bar. (Maximum test pressure is 31 bar.) Test for leaks. Repair as needed to ensure a leak-free circuit. When the circuit is successfully leak tested, allow the nitrogen to escape to the atmosphere through the pump port on the gauge manifold. Repeat with the second circuit.

6.2.3 Pressure test of MASA and field installed piping

For PED requirements the installation needs to be pressure tested at 110% of the design pressure. The MASA condensor unit was pressure tested in the factory. It is forbidden to redo a pressure test on the MASA unit as severe damage will occur.

6.2.3.1 High pressure side pipes

The field installed piping should be pressure tested. If the design pressure of the pipes is less than 41,4 bar, manual resettable pressure switch with a setting of the design pressure or less is needed in the field installed piping.

6.2.3.2 Low pressure side pipes

The field installed piping should be pressure tested at 28.2 bar.

6.2.3.3 Pressure test for field installed piping

During the pressure test, the shut-off valves of the MASA unit must be closed. Only the field installed piping can be pressurized. It will be necessary to put a charge point in the field installed piping.

DANGER : Isolate the MASA unit during the pressure test of the field installed piping by closing the shut-off valves (2 per circuit) at 45.5 bar.

6.3 Evacuate the Circuits

Evacuate one circuit at a time. Use a vacuum pump and micron gauge. Each circuit must be evacuated to hold a 10 mbar vacuum. Vacuum must be pulled on both the discharge (high) and suction (low) side. Do the suction side first; and the compressor discharge side second. To establish that a circuit is leak-free and moisture-free, a standing vacuum test is recommended. Close off the valve to the vacuum pump and observe the micron gauge. If the vacuum gauge does not rise above 10 mbar in one minute, the evacuation should be complete. If vacuum gauge does rise above 10 mbar in one minute, evacuation is incomplete or the system has a leak. Repeat as needed until evacuation is complete. The evacuation process must be done on each circuit.

NOTE: Evacuation will not remove moisture from POE oil. Moisture must be prevented from getting in the oil.

6.4 R-410A Refrigerant Charge

Use only R-410A refrigerant.

NOTE: Outdoor temperature must be between 21-35°C for verifying superheat and subcooling. If temperature is not within this range, consult the factory service department before charging.

If equipped with an optional hot gas bypass, disable the hot gas bypass valve before charging. Remove cap and backoff spring tension until valve is disabled. (**NOTE:** See Paragraph 8.3.3 to reset.)

Estimate the refrigerant charge for each circuit. **TABLE 6** lists the weight of refrigerant required for each condenser (condenser coil and receiver) plus the amount per meter depending on size and length of the liquid line.

Charge the refrigerant slowly through the gauge port on the liquid line. **R-410A refrigerant must be charged as a liquid.**

Provide in the field installed liquid line a charge point. That charge point is also necessary for pressure testing (see 6.2.3).

Table 6 Condenser Refrigerant Charge by Weight and Line Charge per Size and Length of Liquid Line

MASA Size	Circuit	15	22	30	37	44	59
Condenser Refrigerant Charge (kg)	A	5,3	5,7	5,9	7,4	6,9	8,0
	B	5,7	7,1	7,3	8,1	8,1	9,7
<i>PLUS</i> kg listed below of R-410A refrigerant per each 10m actual length of liquid line by tubing size							
Liquid Line Tubing Size (OD)	gr of R-410A Refrigerant (saturated liquid @ 25°C) per each 1m of Liquid Line						
1/2	100 gr/m						
5/8	165 gr/m						
3/4	245 gr/m						

WARNING

Do not release refrigerant to the atmosphere. When adding or removing refrigerant, the qualified technician must comply with all national, state/province, and local laws. See Hazard Levels, page 3.

Long Line Sets/High Refrigerant Charge

If the system charge is larger than 9kg, the compressor manufacturer recommends adding 12 ml oil for every kg of refrigerant above 9kg. Use Copeland Ultra 22 CC POE oil.

If because of long line length, the amount of refrigerant charged exceeds the capacity of both the condenser and the receiver, the excess refrigerant will need to be reclaimed during pumpdown. Follow industry standard procedures for reclaiming. Do not release refrigerant to the atmosphere.

7.0 ELECTRICAL & WIRING

7.1 General

The electrical installation may only be carried out by an appropriately qualified person current to IEE regulations. The supply line to the air cooled condensing unit should include a main switch. The minimum distance between the contacts must be more than 3mm. All electrical connections should be made in the electrical control department (see fig. 3). Screw type main terminals for installer are provided. Connection should be in accordance with the terminal marking and the wiring diagram affixed to the unit. Each unit has a wiring diagram in the electrical compartment (see figure 6).

7.2 Supply Wiring

Supply Voltage

The electric supply to the unit must meet stringent requirements for the system to operate properly. Voltage supply should be within $\pm 10\%$ or as stated on the rating plate. Follow instructions below to check.

CAUTION

If this condensing unit is allowed to operate on an electric supply that is not within the specified tolerances, the product warranty shall be void. See Hazard Levels, page 3.

If the power supply is not within these tolerances, contact the power company prior to operating the system.

Check Voltage Supply - See voltage use range on the rating plate. Measure (and record) each supply leg voltage at all line disconnect switches. Readings must fall within the allowable range.

Compressor models such as TFD extensions have an internal line break motor protector. This protector disconnects all three legs of the motor from power in case of an overload or overtemperature condition.

Compressor models such as TWD extensions have a motor protection system with an external electronic control module with four thermistors. The module will trip and remain off for 30 minutes if the motor exceeds a preset value.

NOTE : turning off power to the module will result into immediate reset. The module has a 30 minutes time delay to allow the scrolls to cool down after the motor temperature limit has been reached. Restarting the compressor sensor may cause a destructive temperature build-up in the scrolls. For this reason module power must never be switched with the control circuit voltage!

Thermostat location

The siting of the room thermostat is important. It should not be fitted on a warm wall or surface.

Avoid location in draughty areas or where it may be influenced by heat sources e.g. the sun, process plant, etc. The thermostat or temperature sensor should be mounted on a vibration free surface and mounted about 1,5 meters above floor level Follow the thermostat manufacturers fitting instructions.

Compressor Wiring - A 3-phase scroll compressor must be phased correctly or compressor will operate in reverse. **Since there is a chance of unknowingly connecting the power in such a way as to cause rotation in reverse, it is important to check this on startup.**

CAUTION

Be sure to connect pressure gauges to the suction and discharge lines before startup so that compressor rotation can be checked immediately. Scroll compressors will be destroyed if operated in the wrong direction. See Hazard Levels, page 3.

Before initial startup, connect refrigerant pressure gauges to the compressor suction and discharge lines. At startup, observe the gauges. **If the suction pressure rises and discharge pressure drops, the compressor is operating in reverse and should be shut down.** (After several minutes of operation in reverse, the compressor's internal protector will trip. If a compressor is repeatedly allowed to restart and run in reverse, the compressor will be permanently damaged.) **Turn off the power and switch the 3-phase line voltage wiring connections before restarting the unit.**

Figure 6b - Wiring Diagram MASA 30, 44

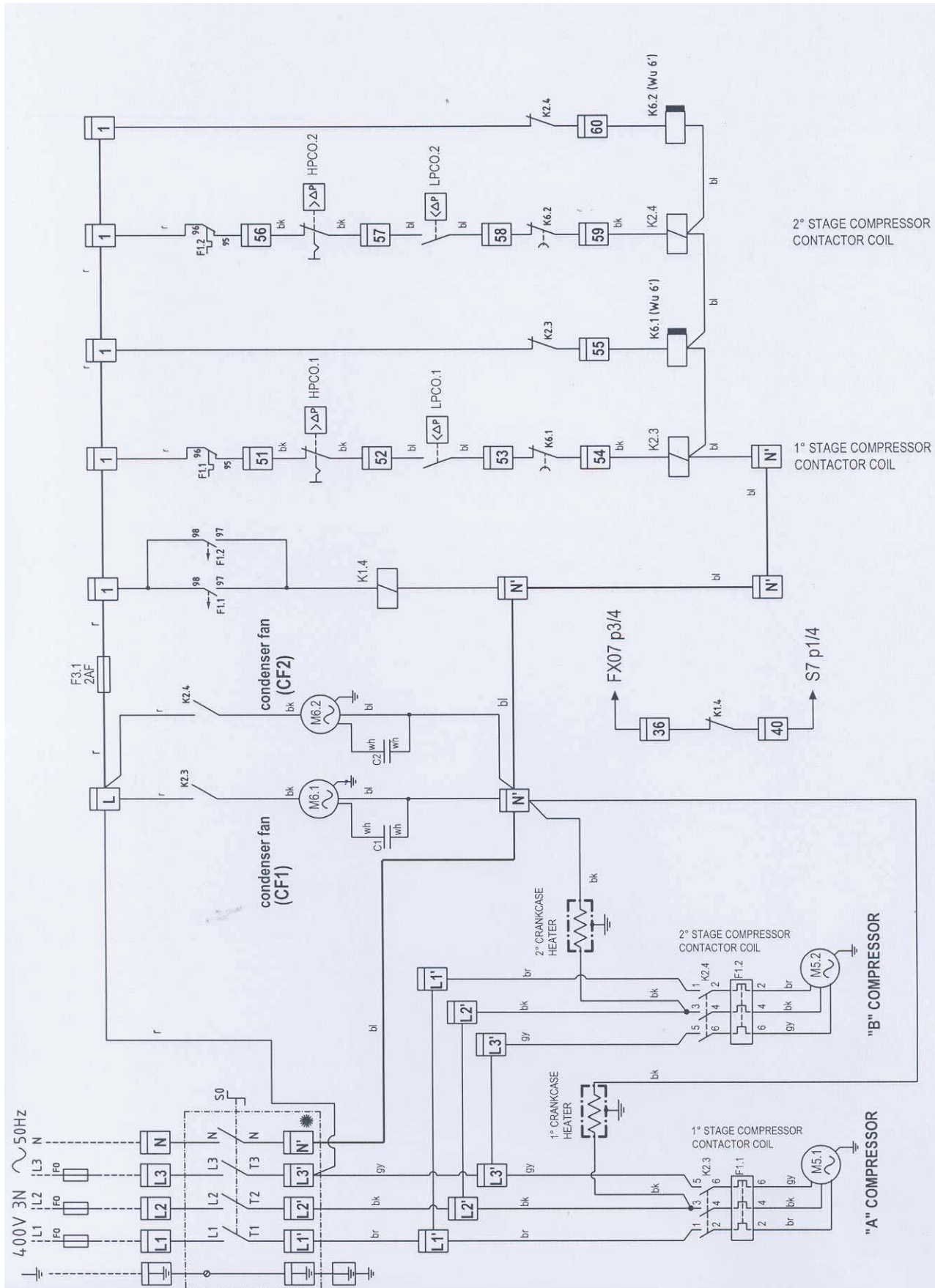

8.0 CONTROLS & OPERATIONS

8.1 Digital control system

An FX07 platform was programmed to work properly with a PREEVA (SDH or RDH) and a MASA appliance and can be supplied as option. An anti-short cycling protection for the compressors is integrated in the FX07. When using another digital platform, it is necessary to order the anti-short cycle module option. If not, an anti-short cycling of 5 minutes must be programmed in the controller.

8.2 Analog control system

A 3 stage (230V) cooling thermostat must be used. The anti-short cycle relays must be integrated in the MASA unit to protect the compressor. This is an option which needs to be specified at the moment of ordering the unit.

8.3 Other Compressor and Refrigerant Controls

Check the wiring diagram on the unit to determine if it has optional controls.

NOTE: Standard with Reznor PREEVA with digital FX07 controls.

8.3.1 High Pressure Cutoff

The high pressure cutoff control is located in the discharge line as it exits the compressor. If the discharge pressure exceeds the high pressure cutoff setting ($40,2 \pm 0,7$ bar), the control will stop compressor and condenser fan operation. The high pressure cutoff control is a manual reset device. It can be reset when the pressure drops below the differential setting (28 ± 1 bar)). Correct the problem before resetting the device to restart operation of the system.

8.3.2 Low Pressure Cutoff

The low pressure cutoff control is located in the suction line as it enters the compressor. If the suction pressure drops below the low pressure cutoff setting ($2,4 \pm 0,5$ bar), the control will stop compressor and condenser fan operation. The low pressure cutoff control will automatically restart operation when the suction pressure goes above $3,4 \pm 0,5$ bar.

8.3.3 Compressor Protection (option)

Optionally the condensing unit has a five-minute anti-short cycle timer on compressor operation.

8.3.4 Crankcase Heaters

Each scroll compressor in the condensing unit has a band-type crankcase heater. Crankcase heaters must always have been energized for at least 24 hours prior to operating the compressor.

9.0 FINAL CHECKS & START-UP

9.1 General Comments

IMPORTANT

On initial start-up, fill-in the **CONDENSER STARTUP FORM** on page 40. Completed form may be required for warranty.

Assumptions: All connections are made; actual startup is imminent. Site is clean; all excess supplies, scraps, and debris have been removed.

WARNING:

To prevent injury or death due to electrocution or contact with moving parts, lock disconnect switch open when doing checks prior to startup. See Hazard Levels, page 3.

9.1.1 Checklist Prior to Start-up

- Check Clearances.** All clearances must be as illustrated in Paragraph 4.1.
- Electrical Checks**
 - Verify the electrical supply matches voltage rating of the unit. (Refer to the rating plate.)
 - Check the wiring for loose connections or damaged wire. Be sure to check the black molded plastic plug or terminal block on the compressor. Tighten plugs and connections. Replace damaged wiring. (See Paragraph 7.3 for replacement wiring requirements.)
 - Check all field wiring against the wiring diagram. Be sure all field-installed controls are in place. Be sure that wire gauges are as required for the electrical load. All field wiring must comply with the National Electric Code and local regulations.
 - Be certain that the electrical entrances are sealed against the weather.
 - Check that fuses or circuit breakers are in place and sized correctly.
- Be certain the manual reset on the compressor high pressure cutoff switch is reset.**
- Check free rotation of condenser fan(s).**
- Remove all shipping supports and restraints.**
- Check field-installed refrigerant lines:**
 - Verify that the filter driers shipped with the unit are installed properly in the correct circuits.
 - Verify that the refrigerant line for 1/3 circuit A on the condenser is connected to 1/3 circuit A on the evaporator. Check that 2/3 circuit B on the condenser is connected to 2/3 circuit B on the evaporator.
 - Verify that the thermal expansion valve bulbs are attached properly to the correct suction line. See Paragraph 6.1.3.3.
 - Verify that the system has been properly evacuated and charged with R-410A refrigerant.
- In addition, verify that all startup checks in the air handling manual have been completed.**

9.2 Start-up

Note: Redo startup procedures when the cooling season begins.

CAUTION

Crankcase heaters must be allowed to warm up for at least 24 hours prior to startup. Disable cooling controls before turning on power to warmup crankcase heaters. See Hazard Levels, page 3.

Assumptions: All pre-startup checks have been made and crankcase heaters have been allowed to warmup for at least 24 hours.

9.2.1 Power Supply Voltage Phasing

- Connect refrigerant pressure gauges to the suction and discharge lines of the compressors and an electric meter to the power supply.

CAUTION

Be sure to connect pressure gauges to the suction and discharge lines before system start-up so that compressor rotation can be checked immediately. Scroll compressors will be destroyed if allowed to operate in the wrong direction. See Hazard Levels, page 3.

- Record the ambient temperature. Adjust the system controller so that a call for cooling exists.

NOTE: If the system has digital controls, outdoor ambient lockouts may prevent mechanical cooling. Temporarily override lockouts by lowering the cooling setpoint. (If installing a PREEVA air handler, refer to the digital programmable control section in the instruction manual.) When testing is complete, reset the controller.

- Because it is a possible to unknowingly connect 3-phase power in such a way as to cause the scroll compressor to rotate in reverse, it is very important to check this on startup.**

Immediately at startup, observe the gauges. If the suction pressure rises and discharge pressure drops, the compressor is operating in reverse and must be shut down. Turn off the power and switch the 3-phase line voltage wiring connections before restarting the unit.

Important note

If allowed to operate for several minutes in reverse, the compressor's internal protector will trip. If a compressor is repeatedly allowed to restart and run in reverse, the compressor will be permanently damaged.

IMPORTANT

All refrigeration checks **MUST** be made by a refrigeration technician qualified in R-410A refrigerant. Equipment and tools **MUST** be designed for R-410A refrigerant.

9.2.2 Operating Sequence

- For a three-stage cooling sequence, the operating sequence is #1 (Circuit A Compressor); then #2 (Circuit B Compressor); and then #1 and #2 (both Circuit A and Circuit B Compressors).

9.2.3 Refrigerant Charge

PREPARATION:

- To verify superheat and subcooling, outdoor temperature must be between 21-35°C. If temperature is not within this range, consult the factory service department before charging.
- Operate for 30 minutes for system to stabilize.
- Check BOTH refrigerant circuit A and circuit B;** isolate each circuit before measuring superheat and subcooling.
- If the circuit has an optional hot gas bypass valve, disable it before measuring superheat and subcooling.** To disable, remove cap and backoff spring tension. Be sure to reset after checking (See Paragraphs 8.3.3 and 9.2.4).

9.2.3.1 **Check SUBCOOLING**

- Measure and record temperature and pressure of the liquid line at the condenser coil outlet.

STEP 1) Record Measurements: Temperature = _____ °C and Pressure = _____ barg

STEP 2) From **Temperature/Pressure Conversion Chart, APPENDIX, page 40**, convert Measured Pressure (STEP 1) to _____ °C

STEP 3) Subtract Measured Temperature (STEP 1) from Temperature from Conversion Chart (STEP 2)
_____ °C - _____ °C = _____ K degrees of Subcooling

Recommended subcooling with outdoor temperature range of 21-35°C is 7-8 K.

Too much subcooling indicates a refrigerant overcharge. To reduce the subcooling, remove excess refrigerant. Too little subcooling indicates a refrigerant undercharge. To increase subcooling, slowly add R-410A refrigerant.

WARNING

Do not release refrigerant to the atmosphere. When adding or removing refrigerant, the qualified technician must comply with all national, state/province, and local laws.

9.2.3.2 Determine SUPERHEAT

Measure and record temperature (insulate probe from surrounding air temperature) and pressure in the suction line at the compressor inlet.

STEP 1) Record Measurements: Temperature = _____ °C and Pressure = _____ barg

STEP 2) From **Temperature/Pressure Conversion Chart, APPENDIX, page 40**, convert Measured Pressure (STEP 1) to _____ °C

STEP 3) Subtract Measured Temperature (STEP 1) from Temperature from Conversion Table (STEP 2)
_____ °C - _____ °C = _____ K degrees of Superheat

Recommended superheat at is 4.5-6.7°C.

Typically, too much superheat indicates that the evaporator coil is undercharged. Too little superheat typically indicates that the evaporator coil is overcharged and may potentially flood liquid refrigerant to the compressor. To reduce the superheat, adjust the thermal expansion valve by turning the adjusting stem counterclockwise. To increase the superheat, adjust the thermal expansion valve by turning the adjusting stem clockwise.

9.3 After Startup:

Assumptions: All checks have been successfully performed and the system is operating properly. All panels and doors are secure. The area has been cleared of any excess supplies, scrap, and debris.

- Check that the information on page 44 has been completed. After startup, put this manual **with completed startup form** (page 41), the warranty form, and any other instructions provided with the unit in the Literature Bag. Return the “Literature Bag” to the low voltage compartment of the unit or give it to the building owner for safe keeping.

10.0 MAINTENANCE & SERVICE

WARNING

Turn off the power before performing all maintenance procedures (except to check subcooling & superheat. Lock disconnect switch in OFF position. See Hazard Levels, page 3.

10.1 General

This condensing unit will operate with a minimum of maintenance. To ensure long life and satisfactory performance, an air conditioning system that is operating under normal conditions should be inspected according to the Maintenance Schedule below. If in an environment where an unusual amount of dust or soot or other impurities are present, more frequent inspection is recommended.

The procedures in the schedule below are only for the condensing unit. Refer to and comply with the maintenance schedule for the Reznor PREEVA unit or other air handler with evaporator.

10.2 Maintenance Schedule

Beginning of the cooling season or more frequently in year-round cooling climate:

- Inspect the wiring for any damaged wire. Replace damaged wiring.
- Inspect the condenser fan. Clean as needed. See Paragraph 10.3.
- Inspect/clean condenser coil. See Paragraph 10.4.
- Check compressor operation. See Paragraph 10.5.
- Check refrigerant pressure and temperatures (both superheat and subcool). These measurements must be taken when the system is in operation. See Paragraph 10.5.

NOTE: If replacement parts are required, use only factory-authorized parts. For information, call your supplier.

Figure 7 - Electrical Compartment showing Control Locations

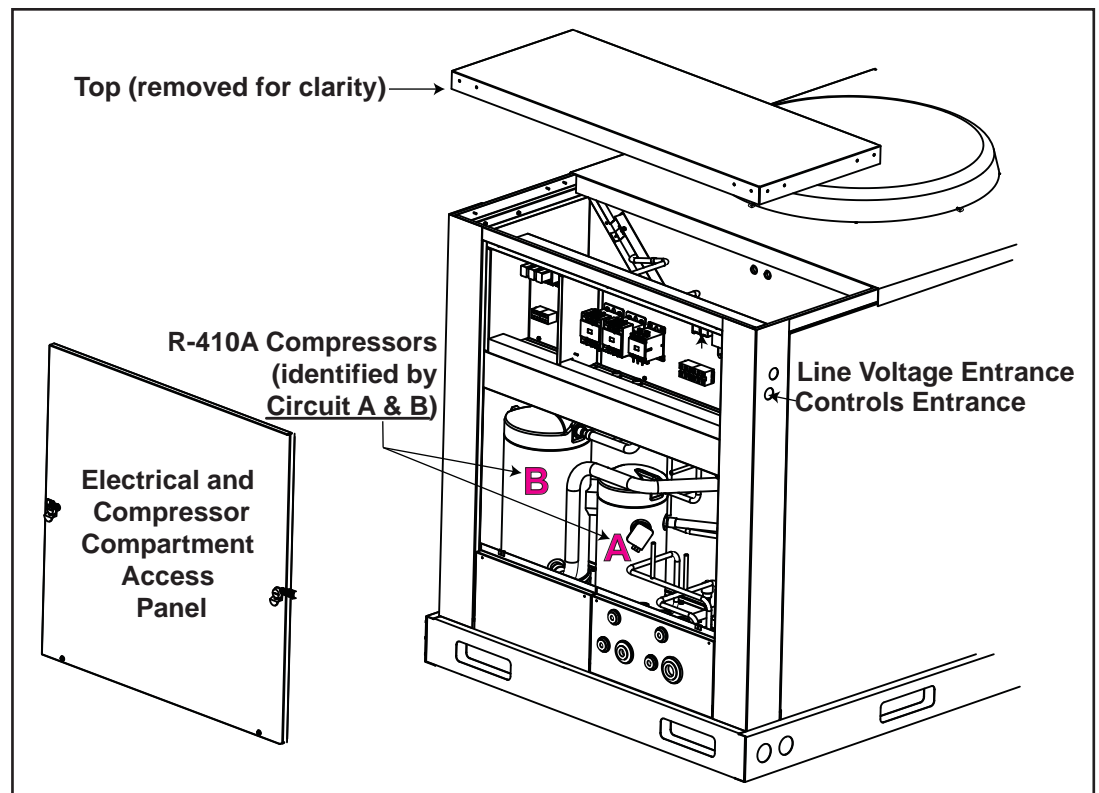

10.3 Condenser Fan(s) Maintenance

Figure 8 - Condenser Fan Rotation and Fan Blade Spacing from Top Edge of Fan Orifice

Check condenser fans. Carefully clean debris and dirt from guards, fan blades and motors. If any parts need to be replaced, use only factory-authorized replacement parts.

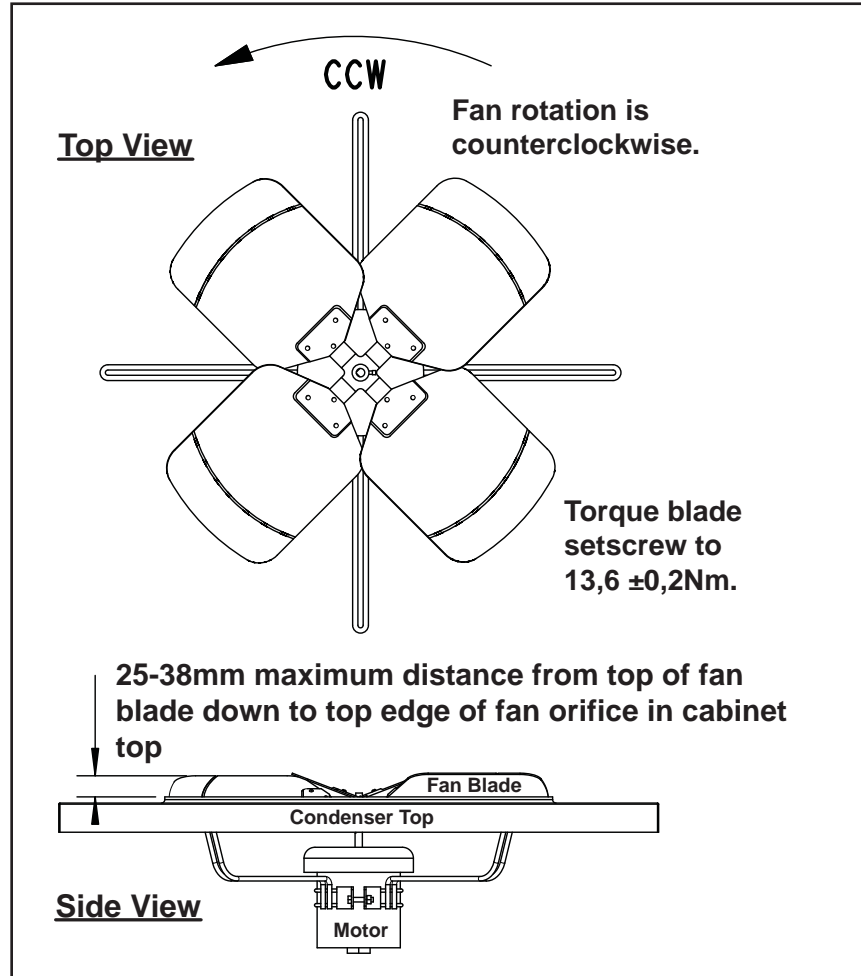

10.4 Condenser Coil Maintenance

Figure 9 - Remove the Optional Coil Guard

Unless equipped with an optional coil guard, the entering airflow side of the condenser coils can be reached for cleaning without removing any components. If there is a coil guard, remove the screws holding the guard.

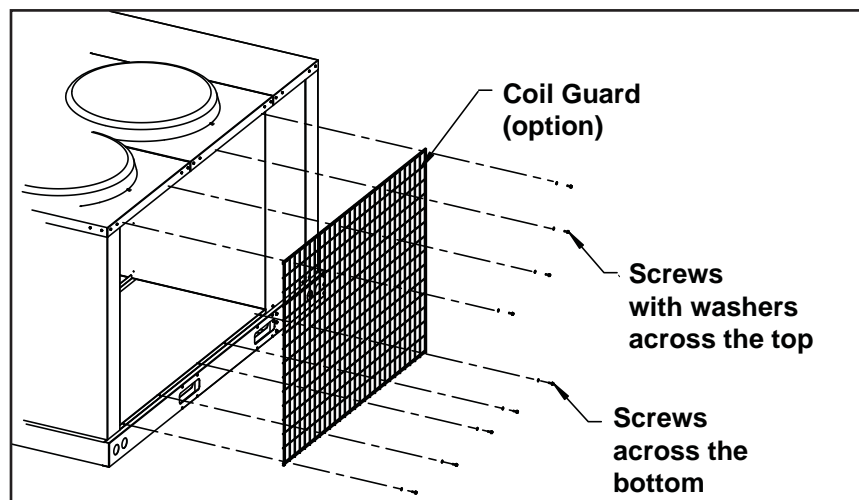

10.5 Compressor Maintenance and Replacement

Instructions for Cleaning Coil

- 1) Verify that the electrical power has been turned off and the disconnect switch locked.
- 2) Use a soft brush to remove any dirt and debris from the coil.
- 3) Spray with cold or warm (not hot) water and a cleaning solution (non-acid based coil cleaner is recommended). Due to possible damage to the coil, **do not use high pressure spray**.
- 4) When clean, rinse with cool, clean water.

If additional cleaning is required or if the coil must be removed for any reason, consult the factory. Be prepared to provide rating plate and installation information.

DANGER

The refrigeration circuits are high pressure systems. Hazards exist that could result in personal injury or death. It is therefore required that the removal and installation of this scroll compressor be performed by a technician qualified in R-410A refrigerant. See Hazard Levels, page 3.

DANGER

Never use oxygen to pressurize a refrigeration system. Oxygen can explode on contact with oil and could result in personal injury or death. When using high pressure gas such as nitrogen for this purpose, **ALWAYS USE A PRESSURE REGULATOR** that can control the pressure down to 0,1 bar. Failure to use a regulator will result in extremely high pressure which could exceed the burst pressure of the compressor or other system components and result in personal injury or death. See Hazard Levels, page 3.

WARNINGS

For your safety, wear eye protection, gloves, and protective clothing when handling refrigerant and oil and when brazing. Have a fire extinguisher nearby. See Hazard Levels, page 3.

Compressor Handling

Do not lift compressor by copper tubing. To prevent internal damage, compressors **must ALWAYS be held upright**.

The following instructions include major points of consideration that will ensure proper installation and protect you from potential personal injury. Use the following 13 steps as a checklist, taking each item in order before proceeding to the next. If more information is required, contact your Reznor supplier.

WARNING

To avoid electrical shock or damaged compressor, power to the compressor(s) **MUST REMAIN OFF** during performance of Steps 1 through 9 below. **LOCK DISCONNECT SWITCH OFF (open)**. See Hazard Levels, page 3.

Step 1. Verify Replacement R-410A Compressor Application

Verify that the replacement compressor is identical to the model being replaced. All components of the manufacturer's Model No. must be identical. System components are matched to the compressor. Replacing a compressor with a model other than the Thomas & Betts (Reznor) specified replacement will void the product warranty.

*Table 7
Replacement
Scroll
Compressors for
R-410A Refrigerant*

MASA Model	Voltage	Refrigerant Circuit	Nominal Tonnage	Compressor Model*	Reznor P/N
15	400/3/50	A	2	ZP20K	03 401US 216672
		B	3	ZP39K	03 401US 216679
22	400/3/50	A	2	ZP29K	03 401US 216675
		B	5	ZP57K	03 401US 216687
30	400/3/50	A	3	ZP39K	03 401US 216679
		B	7	ZP83K	03 401US 216690
37	400/3/50	A	4	ZP54K	03 401US 216683
		B	8	ZP103K	03 401US 216693
44	400/3/50	A	5	ZP57K	03 401US 216687
		B	10	ZP120K	03 401US 216696
59	400/3/50	A	7	ZP83K	03 401US 216690
		B	13	ZP154K	03 401US 220261

*Model No. of replacement R410A scroll compressor must be identical to the one removed including the "E" (ZP39KxExxx) which indicates POE compressor oil.

IMPORTANT: Model of replacement compressor and Model of factory-installed compressor that was removed must be identical.

Step 2. Determine Cause of Initial Failure and Remove the Compressor

In order to prevent a second failure, the cause of the original failure must be determined. Identify the cause and make the necessary repairs.

CAUTION

DO NOT LIFT compressor by copper tubing; damage will occur. Compressor must remain upright. See Hazard Levels, page 3.

WARNING

Wear eye protection, gloves, and protective clothing when handling refrigerant, POE oil, and when brazing. See Hazard Levels, page 3.

- a) **BEFORE REMOVING THE FAULTY COMPRESSOR**, remove R-410A refrigerant charge using proper recovery procedures. This is a scroll compressor. Be sure to remove refrigerant from both the high side and the low side.

WARNING

Do not release refrigerant to the atmosphere. When adding or removing refrigerant, the qualified technician must comply with all national, state/province, and local laws.

- b) Disconnect wires. Compressor wiring is connected either using a black molded plastic plug or wire terminals. Either remove the plug from the compressor or disconnect the wires.
- c) Open access ports so that pressure does not build up in the system. Before unbrazing, cut the suction and discharge tubing with a tubing cutter.

WARNING

Have a fire extinguisher near. The compressor contains oil. There is a risk of fire when unbrazing stubs. See Hazard Levels, page 3.

Use a high temperature torch to disconnect the suction line and the discharge line from the compressor.

- d) Remove the mounting bolts and the compressor. Save the mounting hardware to attach the grommets and sleeves shipped with the replacement compressor.
- e) To test for acid and to assure excess oil does not remain in the circuit, remove oil from the failed compressor. Measure the amount of oil.

CAUTION

In addition to the required eye protection and gloves, care should be taken in handling POE oil because it may cause damage to certain plastics and roofing materials. See Hazard Levels, page 3.

If the oil taken from the compressor and measured is found to be significantly lower than listed in **TABLE 10**, clean the excess oil through use of suction and liquid line filter driers. **Beginning in Step 4, follow the same procedure as for burnout cleanup.**

Use an acid test kit to check the oil for acid. **If acid is found, beginning in Step 4, follow procedures indicated for burnout cleanup.**

Dispose of oil and compressor using an approved environmentally safe disposal method.

Table 8 - Compressor Oil Charge

MASA Size	15		22		30		37		44		59	
Circuit	A	B	A	B	A	B	A	B	A	B	A	B
Compressor	ZP20K	ZP39K	ZP29K	ZP57K	ZP39K	ZP83K	ZP54K	ZP103K	ZP57K	ZP120K	ZP83K	ZP154K
POE Oil (g.)	964	1077	593	1474	1077	1588	1758	3005	1474	3005	1588	3005

Step 3. Mount the Replacement Compressor

Do not remove the dust cover or rubber shipping plugs until all other system connections are complete (i.e. new liquid line filter drier(s) installed and all tubing changes made - see Steps 4 and 5). The amount of time the compressor is open to the atmosphere must be kept to a minimum.

Use the new mounting grommets and sleeves that are shipped with the compressor to mount it. The sleeves will prevent over compression of the grommets. Re-use the mounting bolts from the compressor that was removed. The mounting bolts will bottom out when tight.

Step 4. Install New Filter Driers (Select procedure that applies.)

IF the oil measured in Step 2 was not significantly less than the amount shown in TABLE 10 or the test for acid in **Step 2 did NOT indicate burnout**, install a new R-410A refrigerant liquid line filter drier. The filter drier must be rated for no less than 41bar and be the proper size for the circuit. Because R-410A refrigerant requires POE oil which absorbs moisture quickly, it is important to change the filter drier any time the circuit is opened.

It is recommended to use a tubing cutter when cutting out a filter drier as the desiccant absorbs and holds moisture better when it is cool. Heat from a torch may cause moisture to leave the filter and be absorbed in the oil.

Continue to **Step 5**.

IF the oil measured in **Step 2** was significantly less than shown in TABLE 10 or the test for acid in **Step 2 did indicate compressor burnout**, do the following:

- a) Install a liquid line filter drier. **If there is acid**, install an acid removing filter drier. Size the acid-removing filter drier at least one capacity size larger than normally required for the circuit.
- b) Install a temporary filter drier in the suction line. When there is acid, a 100% activated alumina suction filter drier is recommended. The suction line drier should be sized properly for the circuit and have a service access fitting to monitor pressure drop across the drier. (NOTE: Suction line filter drier must be removed after 72 hours of operation.)

Step 12 includes the remaining procedures required for cleanup of a burnout. Continue to **Step 5**.

Step 5. Braze on Suction and Discharge Lines

Comply with the brazing instructions in Paragraph 6.1.3.6.

Step 6. Check Circuit for Leaks

Comply with instructions in Paragraph 6.2.1.

Step 7. Evacuate the Circuit

Comply with instructions in Paragraph 6.3.

Continue and/or repeat **Steps 6 and 7** until evacuation is complete.

CAUTION

Do not use the replacement compressor as an evacuation assist and *never* apply voltage to a compressor while it is in a vacuum. See Hazard Levels, page 3.

Moisture and air are harmful to the system because they increase the condensing temperature, raise the discharge gas temperature, cause formation of acids, and cause oil breakdown.

CAUTION

Do not leave a circuit open to the atmosphere any longer than minimum required for installation. POE oil in the compressor is extremely susceptible to moisture absorption. Evacuation will not remove moisture from POE oil. See Hazard Levels, page 3.

Step 8. Check the Electrical System

After the system has been evacuated, reconnect the electrical plug to the compressor or the wires to the compressor terminals. It is a normal practice to replace all starting components any time a compressor is changed.

WARNING

Do not apply voltage to the compressor when the plug is removed or terminals disconnected. See Hazard Levels, page 3.

Crankcase Heater

Connect the crankcase heater. The crankcase heater is energized continuously and is extremely important to proper compressor operation and long life.

The crankcase heater must be energized for at least 24 hours before starting the unit or after a power outage of more than 8 hours. Be sure to disable cooling controls before turning on power to warmup crankcase heaters.

CAUTION

Crankcase heaters must be allowed to warm up for at least 24 hours prior to startup. Disable cooling controls before turning on power to warmup crankcase heaters. See Hazard Levels, page 3.

Step 9. Charge the System (R-410A refrigerant)

Charge the circuit according to the information in Paragraph 6.4. R-410A refrigerant must be charged as a LIQUID.

Step 10. System Startup

Connect refrigerant pressure gauges and electric meters. Refer to Start-Up Paragraph 9.2 and perform all procedures required prior to checking sub-cooling and superheat which is done in **Step 11**.

CAUTION

Be sure to connect pressure gauges to the suction and discharge lines before start-up so that compressor rotation can be checked immediately. Scroll compressors will be destroyed if allowed to operate in reverse. See Hazard Levels, page 3.

Step 11. Check Subcooling and Superheat

Refer to Start-Up Paragraph 9.2 and follow instructions for checking sub-cooling and superheat.

WARNING

Do not release refrigerant to the atmosphere. When adding or removing refrigerant, the qualified technician must comply with all national, state/province, and local laws.

Step 12. (Select the procedure that applies.)

IF the oil measured in **Step 2** was significantly less than in TABLE 10 or the acid test in **Step 2** indicated a burnout, do the following:

- a) Operate the unit for several hours. Check the pressure drop through the temporary suction line filter drier. If the pressure drop exceeds 0,5barg, recover the refrigerant, replace the suction line filter drier with the same type as removed, replace the liquid line filter drier, evacuate the circuit, and re-charge with the recovered refrigerant (see Paragraph 6.4). Continue to monitor the pressure drop through the suction line filter drier and repeat the process above until the pressure does not exceed 0,5barg after several hours of operation. (NOTE: System must be allowed to run no more than 72 hours with a suction line filter drier.)
- b) Allow the system to operate for 4-8 hours. Recover the refrigerant and take an oil sample. Retest the oil for acid.
- c) If the test for acid is negative, remove the suction line filter drier, replace the liquid line drier, evacuate, and re-charge the system with the recovered refrigerant.
If the test indicates acid, replace both the liquid line filter drier and the suction line filter drier and repeat b) and c).

CAUTION

After cleanup is complete, remove the suction line filter drier. See Hazard Levels, page 3.

- d) Verify subcooling and superheat (refer to Start-Up Paragraph 9.2).
- e) When the system is operating properly, remove the gauges.

IF the oil measured in **Step 2** was not significantly less than that shown in TABLE 10 or the acid test in **Step 2** did not indicate a compressor burnout, continue to the review in **Step 13**.

Step 13 . Review ALL Steps to ensure that nothing was overlooked.

10.6 Troubleshooting Chart

IMPORTANT:

Do not release refrigerant to the atmosphere! If required service procedures include the adding or removing of refrigerant, the service technician must comply with all national, state or province, and local laws.

SYMPTOM	POSSIBLE CAUSE	REMEDY
A. Compressor will not start.	1. Power off, loose electrical connections, or fuse open.	1. Check disconnect switch, fuses, and wiring. Replace parts or repair as necessary.
	2. Compressor contactor not closing.	2. Check voltage to contactor coil, transformer, slave relay, and system. Replace parts as necessary.
	3. Internal compressor thermal overload open.	3. If compressor is hot, allow 2 hours to cool. See D. below.
	4. Compressor defective.	4. Check compressor for electrical failure. Compressor may be seized; check refrigerant. If necessary, replace compressor.
	5. High or low pressure switch open or defective.	5. If manual reset (high pressure), reset switch. (Switch opens at 40bar and will not reset above 32 bar.) If auto reset (low pressure) does not reset and everything else is OK, replace switch.
B. Compressor starts but cuts out on low pressure (low pressure switch activates at 45 psig.)	1. Low refrigerant charge.	1. Check subcooling and superheat. (See Paragraph 9.2)
	2. Airflow restricted.	2. Check for dirty evaporator coil, dirty filters, closed dampers, iced evaporator coil, or improper belt. Check motor amps. Check duct design.
	3. Restriction in refrigerant line.	3. Check refrigerant pressure; check and adjust thermal expansion valve. If not functioning properly, check for pressure drop across the filter drier.
	4. Defective low pressure switch.	4. Check calibration of switch.
C. Compressor starts but cuts out on high pressure switch.	1. Refrigerant overcharge.	1. Check subcooling and superheat. (See Paragraph 9.2)
	2. Condenser fan motor defective.	2. Check fan motor(s).
	4. Air or non-condensables in system.	4. Check high side equalized pressure reading with equivalent outdoor temperature.
	5. Defective high pressure switch.	5. Check calibration of switch.
	6. Restriction in discharge or liquid line.	6. Check refrigerant line pressures, check thermal expansion valves.
	D. Compressor cuts out on thermal overload.	1. Low voltage.
2. Sustained high discharge pressure.		2. Check running amperage and conditions described in H.
3. High suction and discharge pressures.		3. Check thermal expansion valve setting. Check for non-condensables in the system.
4. Defective compressor overload.		4. If compressor is hot, allow compressor to cool for two hours. Recheck for open circuit.
5. Compressor operating in reverse.		5. Switch the 3 phase line voltage wiring connections.
6. Improper refrigerant charge.		6. Check subcooling and superheat. (See Paragraph 9.2)
7. Bearings or pistons too tight.		7. Check for low oil level.
8. Allow time for compressor to cool.		8. Check dome temperature of the compressor.
E. Noisy compressor	1. Refrigerant overcharge.	1. Check subcooling and superheat. (See Paragraph 9.2)
	2. Compressor operating in reverse.	2. Switch the 3 phase line voltage wiring connections.
	3. Liquid floodback.	3. Check thermal expansion valve setting. Check for refrigerant overcharge. Check subcooling and superheat. (See Paragraph 9.2).
	4. Tubing rattle.	4. Dampen tubing vibration by taping or clamping. Carefully bend tubing away from contact where possible.
	5. Compressor defective.	5. Check internal parts. Replace parts or compressor as needed.

SYMPTOM (cont'd)	POSSIBLE CAUSE (cont'd)	REMEDY (cont'd)
F. High suction pressure	1. Excessive load on evaporator coil.	1. Check for high entering wet bulb temperature. Check for excessive air.
	2. Compressor is unloaded.	2. Check head pressure; check thermal expansion valve if not functioning properly; check pressure drop across filter drier.
	3. Expansion valve not secured to suction line or valve defective.	3. Check operation of the thermal expansion valve. Ensure bulb is secure and insulated (See Paragraph 6.1.3.4).
G. High discharge pressure.	1. Thermal expansion valve setting.	1. Check thermal expansion valve and superheat.
	3. Refrigerant charge.	3. Check subcooling and superheat. See Paragraph 9.2.
	4. Condenser fan motor defective.	4. Check operation of condenser fan motor(s).
	5. Non-condensables in the system	5. Clean the circuit.
H. Suction pressure is too low.	1. Refrigerant undercharge.	1. Check pressures and subcooling. See Paragraph 9.2.
	2. Blower running backward.	2. Interchange any two wires of 3 phase wiring connections.
	3. Loose blower, pulley, or belts.	3. Check air handler drive pulley alignment and belt tension.
	4. Defective or improperly adjusted expansion valve.	4. Check superheat (Paragraph 9.2) and thermal expansion valve.
	5. Dirty filter.	5. Check filter and evaporator coil. Clean or replace as needed.
	6. Too little air flow or low entering air temperature.	6. Check airflow and entering air wet bulb conditions.
	7. Restriction in suction or liquid line.	7. Check refrigerant circuit for restriction.
J. Head pressure too low.	1. Insufficient refrigerant charge.	1. Check superheat and subcooling (Paragraph 9.2). Check for a leak.
	2. Defective or improperly adjusted expansion valve.	2. Check superheat and thermal expansion valve.
	3. Low suction pressure.	3. See "H. Suction pressure too low" above.
	4. Defective compressor.	4. See "F. High suction pressure" above.
K. Compressor short cycles.	1. Thermostat location or malfunction.	1. Check thermostat/control.
	2. Improper refrigerant charge.	2. Check subcooling and superheat (Paragraph 9.2).
	3. Defective high or low pressure control.	3. Check high or low pressure switch. Replace as needed.
	4. Liquid floodback.	4. Possible tight bearings.
	5. Defective expansion valve.	5. Check thermal expansion valve and superheat.
	6. Poor air distribution.	6. Check ductwork for recirculating.
	7. High discharge pressure.	7. See "G. High discharge pressure." above.
	8. Leaking discharge valves in compressor.	8. See "F. High suction pressure" above.
L. Running cycle is too long or unit operates continuously.	1. Refrigeration undercharged.	1. Check subcooling. (Paragraph 9.2)
	2. Dirty filter or evaporator coil.	2. Check filter, coil, and airflow.
	3. Dirty or clogged condenser coil.	3. Check coil and airflow.
	4. Air or other non-condensables in system.	4. Check equalized high side pressure with equivalent outdoor temperature.
	5. Defective compressor.	5. See "F. High suction pressure" above.
	6. Restriction in suction and liquid line.	6. Check for restrictions in refrigerant circuit.
	7. Control contacts stuck.	7. Check wiring.
M. Supply air temperature is too high.	1. Refrigerant undercharge or leak in system.	1. Check subcooling and check for leaks.
	2. Evaporator plugged with dirt or ice.	2. Check evaporator, airflow and filter.
	3. Improperly adjusted or defective expansion valve.	3. Check superheat and thermal expansion valve. Check thermal expansion valve bulb.
	4. Defective compressor.	4. Check compressor for proper operation.
	5. High discharge pressure.	5. See "G. High discharge pressure" above.
	6. Airflow is too high.	6. Check external static pressure.
N. Supply air temperature is too low.	1. Airflow is too low.	1. Check evaporator coil; check filters; check for closed dampers or grills; check drive for loose parts, belts, or misalignment; check external static pressure.
	2. Return air temperature too low.	2. Check entering air wet bulb conditions.
O. Liquid line is too hot.	1. Refrigerant undercharge.	1. Check subcooling.
	2. Dirty/plugged condenser coil.	2. Clean coil.
	3. Non-condensables in the circuit.	3. Clean the circuit.
	4. Condenser fan motor defective.	4. Check condenser fan motor(s).
	5. High discharge pressure.	5. See "G." above.

10.7 Spare parts list

DESCRIPTION		PART NUMBER
THERMAL EXPANSION VALVE	TX3-Z34	60 90000 334
THERMAL EXPANSION VALVE	TX3-Z35	60 90000 335
THERMAL EXPANSION VALVE	TX3-Z36	60 90000 336
THERMAL EXPANSION VALVE	TX3-Z37	60 90000 337
THERMAL EXPANSION VALVE	TX6-Z13	60 90000 613
THERMAL EXPANSION VALVE	TX6-Z14	60 90000 614
SOLENOID TSV 12/65 pp	1/2"	60 90001 1265
SOLENOID TSV 58/150 pr	5/8"	60 90001 58150
SIGHT GLASS Sg 1/2s	1/2"	60 90002 12
SIGHT GLASS Sg 5/8s	5/8"	60 90002 58
FREEZE PROTECT A19abc-9103		60 90003
LOW AMBIENT KIT		
PRESSOSTAT RANCO 0 16-6750		60 90004
CAPILLARY TCK-1000-V		60 90005
SCHRADER MV-9602(AVS-64)		60 90006

APPENDIX

IMPORTANT Reminders about R-410A Refrigerant and POE Oil

- Installation, maintenance, and service should only be performed by an HVAC technician qualified in R-410A refrigerant. The qualified technician must comply with all cautions, warnings, and dangers in these instructions and with all national, state/province, and local regulations.
- Due to higher pressure of R-410A refrigerant, use **ONLY** components, service equipment, and tools designed for R-410A refrigerant. **DO NOT USE** components, tools, or service equipment designed for R-407C refrigerant.
- R-410A requires a different gauge set than those used for R-407C.
- Leak detector should be designed to detect HFC refrigerant.
- Use hoses with at least 50bar service pressure rating.
- Charge R-410A system with **LIQUID** refrigerant. R-410A refrigerant cylinders are rose color (pink) and have a dip tube which allows liquid to flow out of the cylinder in the upright position.
- An R-410A liquid line filter drier rated for 41bar and sized for the circuit is required on each circuit and must be replaced any time the system is opened. Cut filter drier out with a tubing cutter.
- Model MASA R-410A compressors require Ultra 22CC POE oil.
- POE oil absorbs moisture quickly; do not expose oil to the atmosphere.
- Vacuum pumps do not remove moisture from POE oil.
- Do not vent R-410A refrigerant to the atmosphere.
- Do not use capillary tube coils with R-410A refrigerant.

APPENDIX (cont'd)

Model MASA Technical Information

General

MODEL		15	22	30	37	44	59
Nominal capacity (KW)		14,6	21,9	29,2	36,5	43,7	58,3
Stage Capacity	circuit A	4,7	7	9,9	12	14,9	20,4
	circuit B	9,9	14,9	19,3	24,5	28,8	37,9
Absorbed Power (KW)		4,4	5,8	8,4	10,8	14,1	17,2
Sound Level dB (A)		54,5	54,8	57,5	57,5	57,9	58,4
Operating Weight	Kg	200	209	287	317	340	350
Condenser Fan	Type	axial fan					
	RPM	940					
	Diameter - mm (Qty)	660(1)		660(2)			
	Motor HP	3/4(1)		3/4(2)			
	Nominal air flow (m3/h)	8500		17000			
	Watts	590		1180			
Condenser Coil	Type	Aluminum - Micro Channel					
	Rows - FPI	1- 20					
Connection Outlet Sizes -		7/ 8					
Condensing unit (inches)	Circuit A - suction line						
	Circuit B - suction line	7/ 8		1 3/ 8			
	Circuit A - liquid line	1/ 2					
	Circuit B - liquid line	1/ 2					
Filter- Drier Connection Sizes (inches)	Circuit A - liquid line	1/ 2					
	Circuit B - liquid line	1/ 2					5/8

CAPACITY @ euro vent conditions Ambient 35°C, SST 7°C

Sound pressure @ 10m in free field

APPENDIX (cont'd)

Performance tables

MASA - 15												
SST (°C)	Circuit	Description	Ambient (°C)									
			16	21	27	29	32	35	38	41	46	
-1,1	A	TC (W)	4787	4343	3974	3812	3662	3524	3396	3276	3061	
		SDT (°C)	18,9	19,5	24,7	24,5	26,2	29,1	33,9	37,1	40,5	
	B	TC (W)	8147	7337	6792	6553	6399	6240	6116	5977	5768	
	Total	SDT (°C)	24,4	24,8	28,3	31,6	36,7	38,1	38,9	42,5	44,0	
1,7	A	TC (W)	12934	11680	10766	10365	10061	9764	9511	9254	8828	
		kW	2,2	2,4	2,5	2,9	3,1	3,6	3,7	4,0	5,5	
	B	TC (W)	5511	5013	4598	4414	4245	4088	3943	3807	3562	
	Total	SDT (°C)	23,9	25,1	29,9	30,8	33,0	36,0	40,3	43,4	47,3	
4,4	A	TC (W)	9379	8485	7878	7607	7437	7258	7119	6961	6722	
		SDT (°C)	28,9	30,3	34,5	37,8	42,3	44,6	46,4	49,8	51,8	
	B	TC (W)	14890	13498	12475	12022	11682	11346	11062	10768	10284	
	Total	kW	2,4	2,7	2,8	3,2	3,5	3,9	4,0	4,3	5,5	
7,2	A	TC (W)	6214	5668	5210	5007	4820	4646	4485	4334	4061	
		SDT (°C)	28,4	30,2	34,5	36,3	38,8	41,8	45,4	48,4	52,7	
	B	TC (W)	10575	9612	8951	8672	8467	8270	8107	7940	7674	
	Total	SDT (°C)	32,6	35,3	40,0	43,2	47,0	49,9	52,4	55,4	58,0	
10,0	A	TC (W)	16789	15280	14161	13679	13287	12916	12591	12274	11735	
		kW	2,6	2,9	3,2	3,6	3,8	4,2	4,3	4,7	5,6	
	B	TC (W)	6896	6307	5811	5591	5387	5198	5021	4856	4557	
	Total	SDT (°C)	32,2	34,8	38,5	40,8	43,4	46,2	49,0	51,8	56,3	
12,8	A	TC (W)	11734	10718	10012	9733	9489	9276	9086	8916	8624	
		SDT (°C)	35,5	39,6	44,8	47,7	50,7	53,7	56,6	59,1	62,2	
	B	TC (W)	18630	17025	15823	15324	14877	14473	14107	13772	13181	
	Total	kW	2,8	3,2	3,5	3,8	4,1	4,4	4,6	4,9	5,5	
15,0	A	TC (W)	7557	6931	6401	6165	5947	5743	5552	5374	5050	
		SDT (°C)	35,4	38,6	41,9	44,1	46,4	48,7	50,8	53,2	58,0	
	B	TC (W)	12858	11802	11059	10758	10504	10275	10074	9888	9572	
	Total	SDT (°C)	37,5	43,3	48,8	51,3	53,5	56,1	58,6	60,5	63,9	
17,5	A	TC (W)	20415	18733	17460	16923	16450	16018	15626	15262	14622	
		kW	2,9	3,4	3,8	4,0	4,3	4,5	4,8	5,0	5,6	
	B	TC (W)	8196	7539	6980	6730	6498	6281	6078	5888	5541	
	Total	SDT (°C)	37,7	41,6	44,7	46,1	47,5	49,0	50,7	52,6	57,5	
20,0	A	TC (W)	13946	12865	12093	11783	11510	11268	11051	10856	10518	
		SDT (°C)	38,6	46,4	51,9	53,9	55,5	56,8	58,0	59,3	62,9	
	B	TC (W)	22142	20405	19073	18513	18008	17549	17129	16744	16059	
	Total	kW	3,0	3,5	4,1	4,2	4,4	4,6	4,9	5,1	5,5	

APPENDIX (cont'd)

MASA - 22

SST (°C)	Circuit	Description	Ambient (°C)									
			16	21	27	29	32	35	38	41	46	
-1,1	A	TC (W)	6984	6323	5442	5319	5026	4958	4620	4543	4700	
		SDT (°C)	26,7	25,8	30,5	29,3	21,9	32,6	28,5	39,8	49,0	
	B	TC (W)	12251	11941	11244	10975	10568	10234	9722	9315	8592	
1,7	Total	SDT (°C)	16,8	23,8	31,8	36,1	31,8	33,7	33,8	36,9	47,2	
	A	TC (W)	19235	18264	16686	16293	15594	15192	14341	13858	13292	
		kW	2,5	3,1	3,7	4,1	4,4	4,8	5,1	5,6	7,3	
4,4	A	TC (W)	7994	7320	6386	6248	5924	5831	5443	5326	5400	
		SDT (°C)	29,3	30,1	34,1	34,5	30,7	38,5	36,6	44,8	53,1	
	B	TC (W)	14330	13898	13035	12663	12160	11727	11136	10654	9835	
7,2	Total	SDT (°C)	23,8	30,2	37,3	40,7	38,9	40,8	41,9	44,7	53,0	
	A	TC (W)	22324	21218	19422	18911	18083	17558	16578	15981	15235	
		kW	2,9	3,5	4,1	4,5	4,8	5,3	5,6	6,1	7,4	
10,0	A	TC (W)	8960	8299	7341	7191	6838	6717	6281	6117	6076	
		SDT (°C)	31,1	33,5	36,9	38,7	38,3	43,4	43,6	48,7	56,0	
	B	TC (W)	16419	15846	14803	14311	13703	13159	12491	11934	11024	
12,8	Total	SDT (°C)	30,5	36,1	41,8	44,4	44,8	46,7	48,5	51,0	57,3	
	A	TC (W)	25379	24146	22144	21501	20542	19876	18771	18050	17101	
		kW	3,4	3,9	4,5	4,8	5,2	5,6	5,9	6,4	7,4	
7,2	A	TC (W)	9882	9263	8307	8145	7770	7616	7134	6915	6729	
		SDT (°C)	32,3	36,0	39,0	41,9	44,1	47,1	48,8	51,5	57,7	
	B	TC (W)	18518	17785	16547	15919	15199	14530	13787	13152	12160	
10,0	Total	SDT (°C)	36,7	41,3	45,4	47,3	49,2	51,0	53,2	55,3	60,2	
	A	TC (W)	28400	27048	24854	24064	22968	22146	20921	20067	18888	
		kW	3,8	4,3	4,8	5,1	5,5	5,8	6,2	6,6	7,4	
12,8	A	TC (W)	10761	10210	9284	9112	8718	8528	8003	7720	7357	
		SDT (°C)	33,2	37,8	40,8	44,2	47,3	49,4	51,7	53,3	58,6	
	B	TC (W)	20628	19714	18268	17486	16646	15841	15024	14310	13241	
7,2	Total	SDT (°C)	42,2	45,5	48,1	49,5	51,7	53,5	55,5	57,4	61,7	
	A	TC (W)	31389	29924	27551	26598	25364	24369	23026	22030	20598	
		kW	4,2	4,6	5,0	5,3	5,6	6,0	6,3	6,6	7,5	
10,0	A	TC (W)	11595	11140	10271	10091	9684	9454	8887	8533	7962	
		SDT (°C)	34,0	38,6	42,2	45,3	47,4	50,3	51,8	54,1	58,9	
	B	TC (W)	22748	21635	19964	19013	18044	17091	16202	15407	14268	
12,8	Total	SDT (°C)	46,7	48,7	49,9	51,2	52,2	53,7	54,8	56,6	61,8	
	A	TC (W)	34343	32775	30235	29104	27728	26544	25088	23939	22230	
		kW	4,6	4,9	5,3	5,5	5,7	6,0	6,3	6,6	7,5	

APPENDIX (cont'd)

MASA -30

SST (°C)	Circuit	Description	Ambient (°C)													
			16	21	27	29	32	35	38	41	46					
-1,1	A	TC (W)	8931	8631	8066	7731	7383	7329	7026	6507	6331					
		SDT (°C)	33,4	36,4	41,7	42,7	43,7	44,0	44,9	48,8	46,0					
	B	TC (W)	22207	19347	16588	15874	15223	14743	14244	13792	13267					
		SDT (°C)	22,3	29,1	36,1	40,4	43,6	45,9	49,8	50,2	57,3					
Total	TC (W)	31137	27979	24654	23605	22606	22072	21270	20299	19598						
	KW	5,3	6,4	6,8	7,6	8,0	8,2	8,7	9,1	9,5						
1,7	A	TC (W)	10344	9831	9184	8884	8565	8337	7951	7609	7121					
		SDT (°C)	33,3	37,7	42,1	43,6	45,4	46,2	49,0	51,4	53,9					
	B	TC (W)	23591	21142	18832	17982	17248	16675	16064	15538	14763					
		SDT (°C)	30,4	36,1	41,6	44,1	46,6	48,8	51,5	54,0	58,4					
Total	TC (W)	33935	30973	28016	26866	25812	25012	24015	23147	21884						
	KW	5,5	6,4	7,1	7,6	8,0	8,2	8,8	9,5	10,0						
4,4	A	TC (W)	11552	10959	10226	9905	9553	9288	9137	8468	7895					
		SDT (°C)	33,0	38,5	41,9	44,4	46,9	48,3	52,0	54,5	59,2					
	B	TC (W)	23593	22301	20817	20087	19363	18686	17955	17269	16041					
		SDT (°C)	32,0	37,9	42,3	45,5	48,2	50,5	53,2	56,6	60,4					
Total	TC (W)	35145	33259	31043	29991	28916	27974	27092	25736	23936						
	KW	5,7	6,4	7,4	7,7	8,0	8,2	8,9	9,8	10,3						
7,2	A	TC (W)	12652	12035	11218	10848	10444	10198	9666	9211	8618					
		SDT (°C)	32,5	39,1	41,3	45,2	48,2	50,5	54,1	58,3	62,5					
	B	TC (W)	22758	23089	22570	22047	21383	20610	19763	18881	17179					
		SDT (°C)	36,6	42,0	43,1	46,4	49,4	51,8	55,1	58,2	63,2					
Total	TC (W)	35410	35124	33788	32895	31827	30808	29430	28092	25796						
	KW	5,9	6,6	7,7	7,8	8,1	8,4	9,1	10,0	10,5						
10,0	A	TC (W)	14027	13135	12247	11930	11607	11110	11202	10337	9128					
		SDT (°C)	31,9	39,4	42,1	46,3	49,4	53,2	55,5	57,6	63,8					
	B	TC (W)	24703	24830	24119	23468	22696	21843	20938	20050	18482					
		SDT (°C)	41,0	45,8	49,7	51,7	53,5	55,8	57,1	59,1	62,2					
Total	TC (W)	38730	37964	36366	35398	34303	32953	32140	30386	27610						
	KW	6,2	6,9	7,9	8,2	8,5	9,0	9,4	10,1	10,8						
55	A	TC (W)	15289	14189	13231	12935	12667	11986	11787	11337	9609					
		SDT (°C)	31,2	39,6	42,5	47,4	50,4	56,1	56,2	57,5	64,5					
	B	TC (W)	25959	26245	25489	24804	23973	23046	22084	21150	19664					
		SDT (°C)	48,2	51,8	54,4	56,0	57,2	59,3	59,2	59,4	61,7					
Total	TC (W)	41248	40434	38720	37740	36639	35032	33870	32487	29273						
	KW	6,7	7,6	8,3	8,9	9,3	10,1	10,1	10,2	11,1						

APPENDIX (cont'd)

MASA - 37

SST (°C)	Circuit	Description	Ambient (°C)													
			16	21	27	29	32	35	38	41	46					
-1,1	A	TC (W)	17518	15899	13778	13208	12337	11807	10854	10313	9755					
		SDT (°C)	10,4	17,7	28,7	25,7	28,4	26,4	31,8	35,1	44,1					
	B	TC (W)	28178	24609	19825	21406	20580	24081	19800	20076	20282					
		SDT (°C)	16,0	17,5	18,8	22,0	24,2	28,0	29,6	33,3	43,4					
	Total	45696	40508	33603	34614	32917	35888	30653	30389	30038						
		kW	3,7	4,3	4,7	5,3	6,7	7,4	8,5	11,2						
1,7	A	TC (W)	17915	16537	14677	14041	13211	12620	11776	11245	10698					
		SDT (°C)	16,3	23,5	33,8	31,8	34,6	33,4	38,5	41,8	50,2					
	B	TC (W)	30512	27357	23042	23842	22828	24909	21507	21390	21435					
		SDT (°C)	23,0	24,8	26,2	29,4	31,5	35,2	36,7	40,3	49,7					
	Total	48427	43894	37718	37883	36038	37529	33283	32635	32134						
		kW	5,0	5,5	6,0	6,7	8,1	8,7	9,7	12,4						
4,4	A	TC (W)	18245	17077	15464	14769	13982	13336	12605	12088	11559					
		SDT (°C)	22,5	29,3	38,1	37,5	40,3	40,2	44,8	47,8	55,0					
	B	TC (W)	32605	29906	26179	26107	24906	25605	23044	22542	22196					
		SDT (°C)	30,3	32,5	33,9	37,0	38,9	42,4	43,7	46,8	55,0					
	Total	50850	46983	41643	40876	38888	38942	35650	34630	33754						
		kW	6,3	6,9	7,5	8,1	8,6	9,4	10,1	11,0	13,3					
7,2	A	TC (W)	18527	17543	16162	15412	14671	13974	13357	12857	12348					
		SDT (°C)	29,0	35,1	41,6	43,0	45,5	47,0	50,6	53,2	58,7					
	B	TC (W)	34497	32280	28867	28222	26839	26203	24440	23564	22656					
		SDT (°C)	38,0	40,5	41,9	44,8	46,4	49,5	50,4	53,0	59,2					
	Total	53025	49824	45028	43634	41509	40177	37797	36420	35004						
		kW	7,9	8,5	9,1	9,7	10,2	10,8	11,4	12,1	14,0					
10,0	A	TC (W)	18771	17951	16787	15987	15291	14547	14044	13563	13077					
		SDT (°C)	35,9	40,8	44,5	48,1	50,4	53,7	56,0	57,9	61,1					
	B	TC (W)	36223	34502	32206	30204	28642	26723	25716	24479	22906					
		SDT (°C)	46,1	48,9	50,3	52,8	54,0	56,4	57,0	58,6	62,2					
	Total	54994	52453	48994	46191	43933	41271	39760	38042	35984						
		kW	9,6	10,2	10,9	11,4	11,8	12,3	12,7	13,3	14,5					
12,8	A	TC (W)	18986	18312	17352	16506	15854	15067	14675	14214	13754					
		SDT (°C)	43,1	46,5	46,6	52,9	54,8	60,2	60,9	62,1	62,3					
	B	TC (W)	37805	36587	35396	32067	30332	27182	26890	25307	23040					
		SDT (°C)	54,5	57,8	59,0	61,0	61,7	63,2	63,3	63,8	64,2					
	Total	56790	54898	52748	48573	46186	42249	41565	39521	36794						
		kW	11,5	12,1	12,8	13,2	13,5	13,8	14,1	14,4	14,7					

APPENDIX (cont'd)

MASA - 44

SST (°C)	Circuit	Description	Ambient (°C)											
			16	21	27	29	32	35	38	41	46			
-1,1	A	TC (W)	17545	14311	12384	11549	11103	10611	10263	9823	9219			
		SDT (°C)	17,6	23,4	29,2	32,1	35,0	38,0	41,0	48,5	52,5			
	B	TC (W)	36293	30124	26400	24807	23951	23025	22380	21576	20504			
		SDT (°C)	24,5	33,6	33,7	35,3	38,4	43,7	49,8	56,7	60,6			
	Total	TC (W)	53839	44435	38784	36355	35053	33636	32642	31399	29723			
		kW	5,7	6,5	8,3	9,5	10,6	11,1	12,6	14,3	15,7			
1,7	A	TC (W)	19319	16090	14141	13293	12832	12326	11963	11510	10881			
		SDT (°C)	27,9	34,0	39,6	42,2	44,5	46,8	48,8	50,7	53,9			
	B	TC (W)	39941	33831	30038	28395	27466	26469	25746	24870	23646			
		SDT (°C)	32,4	37,1	42,0	44,7	47,5	50,7	54,1	58,0	61,6			
	Total	TC (W)	59260	49921	44179	41688	40298	38795	37709	36380	34527			
		kW	7,8	9,3	10,6	11,5	12,2	12,7	13,7	14,8	15,9			
4,4	A	TC (W)	20763	17695	15810	14986	14527	14026	13662	13213	12580			
		SDT (°C)	33,1	38,1	42,7	44,9	47,1	49,3	51,5	52,4	57,1			
	B	TC (W)	42899	37162	33458	31827	30845	29802	29008	28079	26709			
		SDT (°C)	40,4	41,6	46,4	48,2	50,4	53,1	55,8	58,7	61,7			
	Total	TC (W)	63662	54856	49269	46813	45372	43828	42670	41292	39289			
		kW	7,8	10,1	11,4	12,2	12,9	13,2	13,9	15,2	16,0			
7,2	A	TC (W)	21877	19126	17393	16629	16189	15712	15358	14931	14315			
		SDT (°C)	36,2	39,3	42,5	44,2	46,2	48,5	51,2	54,4	62,4			
	B	TC (W)	45166	40116	36661	35103	34088	33022	32167	31202	29695			
		SDT (°C)	34,8	41,2	47,0	49,7	52,1	54,5	56,6	58,6	62,1			
	Total	TC (W)	67043	59242	54053	51731	50277	48734	47525	46133	44010			
		kW	8,5	12,0	12,9	13,5	13,9	14,1	14,1	15,4	16,1			
10,0	A	TC (W)	22661	20384	18888	18220	17816	17384	17053	16664	16087			
		SDT (°C)	50,4	53,4	55,3	55,9	56,5	56,9	57,4	57,5	59,6			
	B	TC (W)	46744	42693	39645	38223	37195	36130	35222	34239	32602			
		SDT (°C)	55,9	56,9	58,0	58,7	59,2	59,6	60,7	62,2	63,6			
	Total	TC (W)	69405	63077	58533	56443	55011	53513	52275	50903	48689			
		kW	13,2	14,0	14,5	14,7	15,0	15,0	15,4	15,8	16,1			
12,8	A	TC (W)	23116	21469	20296	19760	19409	19040	18745	18413	17896			
		SDT (°C)	59,7	61,3	61,2	60,7	60,1	59,4	58,7	62,4	60,5			
	B	TC (W)	47631	44893	42411	41187	40167	39125	38174	37190	35430			
		SDT (°C)	55,9	56,9	58,0	58,7	59,2	59,6	60,7	62,2	63,6			
	Total	TC (W)	70746	66362	62707	60947	59576	58166	56919	55603	53326			
		kW	15,4	16,2	16,1	16,0	15,9	15,9	16,0	16,1	16,1			

APPENDIX (cont'd)

MASA - 59

SST (°C)	Circuit	Description	Ambient (°C)													
			16	21	27	29	32	35	38	41	46					
-1,1	A	TC (W)	21360	20122	19087	18626	18196	17791	17410	17050	16382					
		SDT (°C)	31,9	36,6	42,6	44,7	48,1	50,7	56,4	61,5	74,0					
	B	TC (W)	30112	30479	30499	30504	30507	30509	30510	30510	30511					
		SDT (°C)	34,7	39,5	45,1	47,2	50,3	52,8	57,8	62,3	73,2					
	Total	TC (W)	51473	50600	49587	49130	48703	48300	47920	47560	46893					
		kW	10,3	11,5	13,4	14,1	15,4	16,4	18,7	20,8	26,1					
1,7	A	TC (W)	22967	22307	20918	20560	19877	19650	18565	18006	17250					
		SDT (°C)	33,8	38,2	43,8	45,8	49,1	51,7	57,4	62,6	75,6					
	B	TC (W)	38990	36521	35292	33844	33160	32550	32002	31506	30642					
		SDT (°C)	36,3	41,0	46,3	48,4	51,3	53,8	58,2	62,4	72,5					
	Total	TC (W)	61956	58828	56210	54404	53037	52200	50567	49512	47892					
		kW	10,9	12,0	13,8	14,5	15,8	16,9	19,0	21,0	26,2					
4,4	A	TC (W)	24472	23718	22414	21909	21278	20912	20196	19900	19838					
		SDT (°C)	34,1	38,7	44,3	46,5	49,8	52,5	58,5	63,3	75,9					
	B	TC (W)	40718	38909	37796	36378	35720	35045	34523	34048	33353					
		SDT (°C)	37,6	42,2	47,4	49,6	52,6	55,2	59,9	64,0	74,5					
	Total	TC (W)	65191	62626	60211	58286	56998	55957	54719	53948	53191					
		kW	11,0	12,1	13,9	14,8	16,1	17,3	19,6	21,7	26,3					
7,2	A	TC (W)	25845	25273	24164	23587	22966	22465	21830	21501	21273					
		SDT (°C)	35,4	40,2	45,7	48,0	51,1	53,6	59,1	62,9	73,6					
	B	TC (W)	44470	41668	40022	38892	38204	37592	36999	36459	35512					
		SDT (°C)	38,9	43,3	48,1	50,4	53,3	56,0	60,6	64,5	74,9					
	Total	TC (W)	70315	66940	64186	62479	61170	60057	58829	57960	56785					
		kW	11,6	12,7	14,4	15,3	16,6	17,8	20,0	22,0	27,2					
10,0	A	TC (W)	30851	27200	26418	25901	25210	24604	23559	22717	20954					
		SDT (°C)	38,8	44,0	49,2	51,3	53,8	55,8	59,6	62,1	68,6					
	B	TC (W)	47966	45060	43099	41637	40756	39918	39215	38652	37569					
		SDT (°C)	40,7	44,8	49,0	51,2	53,8	56,5	60,3	64,0	73,6					
	Total	TC (W)	78817	72260	69516	67537	65966	64522	62774	61368	58523					
		kW	12,9	14,1	15,7	16,5	17,5	18,6	20,2	21,7	25,1					
12,8	A	TC (W)	35872	29519	29159	28738	27920	27163	25448	23794	19650					
		SDT (°C)	44,0	50,3	55,3	57,3	59,0	60,3	61,3	62,0	62,2					
	B	TC (W)	50857	47685	45341	44440	43611	43030	42209	41610	40566					
		SDT (°C)	43,6	47,4	51,1	53,2	55,5	58,1	61,2	64,7	73,6					
	Total	TC (W)	86729	77204	74500	73178	71531	70193	67657	65404	60216					
		kW	14,9	16,3	17,7	18,4	19,1	19,9	20,7	21,5	23,4					

APPENDIX (cont'd)

Pressure/ Temperature Chart for R- 410A Refrigerant for Checking Subcooling and Superheat

NOTE: Information in this chart was taken from Coolpack. R-410A gauges do bear these data.

R-410A Refrigerant	
temperature	pressure
°C	bar (abs)
-20,0	4,0
-19,0	4,2
-18,0	4,3
-17,0	4,5
-16,0	4,7
-15,0	4,8
-14,0	5,0
-13,0	5,2
-12,0	5,4
-11,0	5,6
-10,0	5,8
-9,0	6,0
-8,0	6,2
-7,0	6,4
-6,0	6,6
-5,0	6,8
-4,0	7,0
-3,0	7,3
-2,0	7,5
-1,0	7,7
0,0	8,0
1,0	8,2
2,0	8,5
3,0	8,8
4,0	9,0
5,0	9,3
6,0	9,6
7,0	9,9
8,0	10,2
9,0	10,5
10,0	10,8
11,0	11,1
12,0	11,5
13,0	11,8
14,0	12,1
15,0	12,5
16,0	12,8
17,0	13,2
18,0	13,6
19,0	14,0
20,0	14,4
21,0	14,7
22,0	15,2
23,0	15,6
24,0	16,0

R-410A Refrigerant	
temperature	pressure
°C	bar (abs)
25,0	16,4
26,0	16,9
27,0	17,3
28,0	17,8
29,0	18,2
30,0	18,7
31,0	19,2
32,0	19,7
33,0	20,2
34,0	20,7
35,0	21,2
36,0	21,7
37,0	22,3
38,0	22,8
39,0	23,4
40,0	24,0
41,0	24,6
42,0	25,2
43,0	25,8
44,0	26,4
45,0	27,0
46,0	27,7
47,0	28,3
48,0	29,0
49,0	29,6
50,0	30,3
51,0	31,0
52,0	31,7
53,0	32,5
54,0	33,2
55,0	34,0
56,0	34,7
57,0	35,5
58,0	36,3
59,0	37,1
60,0	37,9
61,0	38,7
62,0	39,6
63,0	40,4
64,0	41,3
65,0	42,2
66,0	43,1
67,0	44,0
68,0	45,0

Complete on initial startup. Completed form may be required for warranty. Date: _____

Customer Name: _____ Condenser Model #: _____
 Address: _____ Condenser Serial #: _____
 City: _____ Air Handler Brand: _____
 Contractor Firm Name: _____ Air Handler Model #: _____
 Installing Contractor: _____ Air Handler Serial #: _____

PRE-STARTUP CHECK LIST (See Section References for details.)

- Remove all shipping supports and restraints (Section 3.0)
- Check unit for damage (Section 3.0)
- Check air flow clearances (Section 9.1.1)
- Verify incoming power matches unit rating (Section 9.1.1)
- Check & tighten all electrical connections (Section 9.1.1)
- Check unit for proper field installed wiring (Section 9.1.1)
- Check free rotation of condenser fan(s) (Section 9.1.1)
- Crankcase heater ON for 24 hours (Section 9.2)
- Leak tested field-installed refrigerant lines (Section 6.2.2)
- Check refrigerant line free from rubbing
- Filter driers installed (Section 6.1.3.3)
- Trap installed (if required) (Section 6.1.3.4)
- System evacuated to 10 mbar (1kPa) absolute (Section 6.3)
- Proper start-up of air handling equipment (Section 9.1)
- Condenser A connected to evaporator A (B to B) (Section 6.1)
- Thermal expansion valves properly installed (Section 6.1.3.3)

ELECTRICAL CHECKS

Voltage in: _____ V
 Compressor running forward _____ Y _____ N
 Outdoor Air Temperature: _____ °C
 Compressor Amperage _____ Circuit A _____ Circuit B

PIPING CHECK

Refrigerant line length: Circuit A Circuit B
 _____ Liquid _____ Liquid
 _____ Suction _____ Suction

Leak tested BARG: _____ Circuit A _____ Circuit B
 Hold time: _____ Circuit A _____ Circuit B

Total kg of R-410A added: _____ Circuit A _____ Circuit B

NOTES:

OPERATIONAL DATA

Operate for 30 minutes for system to stabilize	Circuit A	Circuit B
Subcooling Temperature		
Liquid line temperature leaving condenser	°C	°C
Liquid line pressure leaving condenser	barg	barg
Subcooling Temperature temperature	°C	°C
Superheat Temperature		
Suction line temperature leaving evaporator	°C	°C
Suction line temperature entering condenser	°C	°C
Suction line pressure entering condenser	barg	barg
Superheat temperature	°C	°C
Optional hot gas bypass start to open	barg.	barg.
Optional hot gas bypass full open	barg	barg.
Test Conditions		
Condenser fan entering air temperature	°C	°C
Condenser fan leaving air temperature	°C	°C
Evaporator entering dry bulb air temperature	°C	°C
Evaporator entering wet bulb air temperature	°C	°C
Evaporator leaving wet bulb air temperature	°C	°C
Evaporator leaving dry bulb air temperature	°C	°C

INSTALLER MUST COMPLETE THE FOLLOWING:

Installer:

Name _____
Company _____
Address _____

Phone _____

Distributor (company from which the unit was purchased):

Contact _____
Company _____
Address _____

Phone _____

Model No. _____ Serial No. _____ Date of Installation _____

SPECIFIC INSTALLATION NOTES: (i.e. Location, Airflow, Power, Static Pressure, Amps, Gas Pressure, Temperature, Voltage, Adjustments, Warranty, etc.)

BUILDING OWNER OR MAINTENANCE PERSONNEL:

For service or repair

- Contact the installer listed above.
- If you need additional assistance, contact the Reznor Distributor listed above.

Manufacturer

ReznorEurope N.V.

J&M Sabbestraat 130

8930 Menen

Belgium

tel 056 52 95 11

fax 056 52 95 332

e-mail : reznor.europe@tnb.com

Distributor

Reznor U.K. Limited

Park Farm Road

Folkestone - Kent

England

tel 01303-259141

fax 01303-850002

e-mail : sales@reznor.co.uk