

"U" Heat Exchanger Tube with Reflector, Option UB3

Applies To: **Model VR**

**Description/
Application**

Reference NOTE:
 See Technical Form T-VR-CNFG for allowable configurations by size and length.

The "U" shaped heat exchanger tube is used to adapt a Model VR tubular radiant heater to a specific location and/or to provide a balance of radiant heat. The "U" heat exchanger tube may be installed in any length of system from 20 to 70 feet. Comply with the following requirements in positioning the "U" tube:

- **Sizes 100, 125, and 150 require** 20 ft (6.1M) of straight tube length at the burner box before installing an optional "U" tube.
- **Sizes 175 and 200 require** 30 ft (9.1M) of straight tube length at the burner box before installing an optional "U" tube.
- Use only one "U" tube in a system.
- Optional 5-ft tube(s) may be used in a layout with a "U" tube.
- On a "U" configuration, the straight tube length on the burner side of the "U" must be equal to or longer than the tube length on the exhaust side.
- If a "U" configuration is angled, the exhaust side must be the high side.

The "U" shaped heat exchanger tube option includes a reflector which must be field assembled and installed.

Components

FIGURE 1 - Option UB3 Components

Option UB3, Package P/N 205211, includes:

Code	Qty	P/N	Description
"U" Tube and "U" Tube Reflector Parts			
1	1	205212	"U" Heat Exchanger Tube
2	1	268222	"U" Tube Reflector Top
3	1	268223	"U" Tube Reflector Right Side
4	1	268224	"U" Tube Reflector Left Side
	1	120677	"U" Tube Reflector Bracket (shipped in parts bag below)
Coupling and Hardware for Tube Connection			
	1	205546	Compression Coupling
5	2	37661	#10x1/2" Self-drilling Screws (shipped in parts bag below)
Wire Retainer, Hanger Bar, Tube Bracket, and U-Bolt			
	1	209321	Wire Reflector Retainer (for straight tube)
	1	209322	Hanger Bar (for straight tube)
6	1	205586	Tube Bracket (for straight tube)
	1	131785	U-Bolt with Brass Nuts for tube bracket (shipped in parts bag below)
"U" Tube Kit Hardware Bag, P/N 205722, includes items below plus the items above that indicate they are shipped in the parts bag:			
Hardware for assembling and attaching "U" tube reflector			
	14	113275	Screws, #10-32 x 1/2" long
	14	26490	Nuts, Kep #10-32
	2	113807	Washers
	1	120716	1/2" Stainless Worm-drive Clamp
	2	196336	Clip-on, spring steel Receptacle Nut
	2	11813	#10x1/2" Sheetmetal Screws (for clip-on nuts)

WARNING
 Improper installation, adjustment, alteration, service, or maintenance can cause property damage, injury or death. Read the installation, operation, and maintenance instructions thoroughly before installing or servicing this equipment.

Installation Instructions

Reference Heater Installation Manual, Form I-VR

NOTE: Before installation, wipe any excess corrosion inhibitor from the heat exchanger tubes. Failure to do so could result in excessive smoke from the surface of the tubes on initial startup.

Installation should be done by a qualified agency in accordance with these instructions and in compliance with all codes and requirements of authorities having jurisdiction.

1. Install the burner/control box, combustion chamber tube, and any heat exchanger tubes before the "U" tube. Carefully read and follow the instructions in the heater installation manual.
2. **Turbulator Strip Sections** - If the "U" tube is adjacent to the exhaust heat exchanger tube and the heater is 40 to 70 feet in length, install two sections of the turbulator strip in the straight heat exchanger tube before attaching the "U" tube. Follow the instructions in the heater installation manual for inserting turbulator strips.
3. **Connect the "U" Tube** - Before the "U" tube is connected, determine the angle of the final installation (**See FIGURE 3**). The "U" tube may be installed so that the exhaust side of the system is level with or rotated 15°, 30°, or 45° above the burner/control box side.

Use the compression coupling in the kit to attach the "U" tube following the same procedure as the straight tubes, but when inserting the "U" tube into the coupling, the unattached side of the "U" tube may be rotated so that the exhaust side will be up to 15°, 30°, or 45° higher than the control/burner box side. When the "U" tube is at the desired angle, tighten the coupling and insert the two self-drilling screws to hold it in place.

FIGURE 2 - After determining the angle (see FIGURE 3), use a coupling to connect the "U" Tube to the straight tube

2nd, Insert Self Drilling Screws



1st, Slide both the "U" tube and the straight tube into the coupling and tighten the bolts

FIGURE 3 - End View with "U" System at a 45° Angle

- Rotate the "U" tube in the coupling to angle the tubes after the "U" tube. (Exhaust end must be the higher side.) Suspend from the appropriate hole in the hanger bar.
- On the tubes between the burner/control box and the "U" tube, rotate the reflector by loosening the nuts on the "U" bolt (the same as a straight system) and moving the suspension to the appropriate hole in the hanger bar.

Illustration NOTE: For clarity, not all tube hangers and chains are shown. Burner/control box chains are not shown.

Installation NOTES:

Each straight tube section must have one or two suspension points. "U" tube does not require a suspension point. Comply with all requirements in the heater installation manual.

End View of a Model VR with an Optional "U" Tube at a 45° Angle

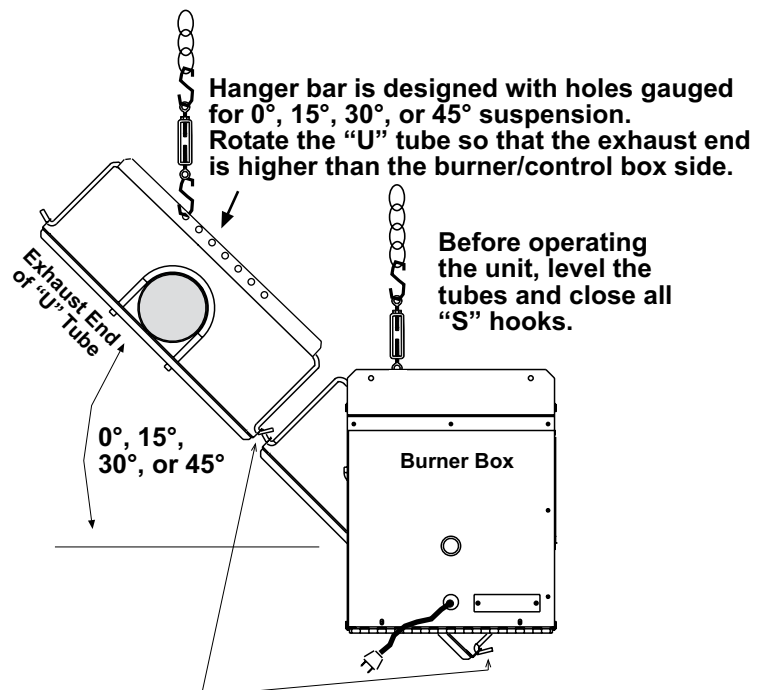

The end of retainer wire with the sharper 45° bend must be on the lower side when reflectors are angled (applies to all retainer wires).

4. **Install the tube downstream of the "U" tube.** The next tube adjacent to the "U" tube requires two suspension points. Attach two tube brackets to the tube (**FIGURE 4**). Attach the wire retainers. Slide the hanger bar over the retainer and suspend from both locations.

FIGURE 4 - The downstream heat exchanger tube adjacent to the "U" tube requires two suspension points. Attach two tube brackets and two wire retainers.

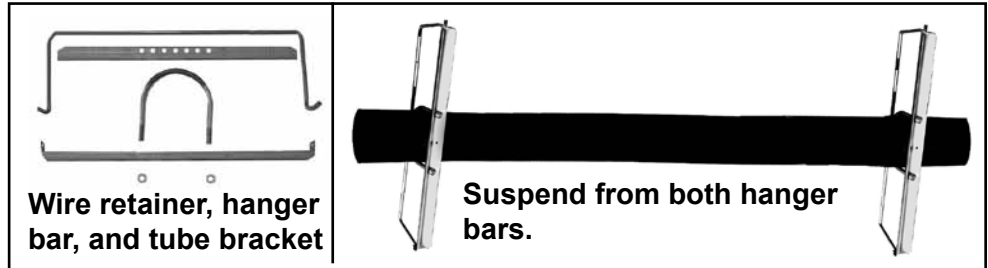

NOTE: One "hook" of the wire retainer is bent 70° and the other 45°. If the reflector is going to be rotated, be sure the side with the sharper 45° bend will be on the lower side.

5. Following the layout, suspend and connect the remainder of the tubes according to the instructions in the heater installation manual. The tubes on both sides of the "U" must be parallel, level, and in the same plane (level or angled 15°, 30°, or 45°).
6. **Install Straight Reflectors between the Burner/Control Box and the "U" Tube** - Starting at the burner/control box follow the instructions in the heater installation manual to install the straight reflectors before the "U" tube. Be sure to comply with all requirements.
 - Leave 1/4" (6mm) space between the combustion chamber reflector and the burner/control box.
 - If reflector is angled, be sure the end of the wire retainer with the sharper 45° bend is on the lower side.
 - Use screws to attach the first reflector section to the first tube bracket.
 - Use clips and screws to join reflectors.
7. **Assemble "U" Tube Reflector** - Assemble the reflector top and sides and attach the reflector bracket as illustrated in **FIGURE 5**.

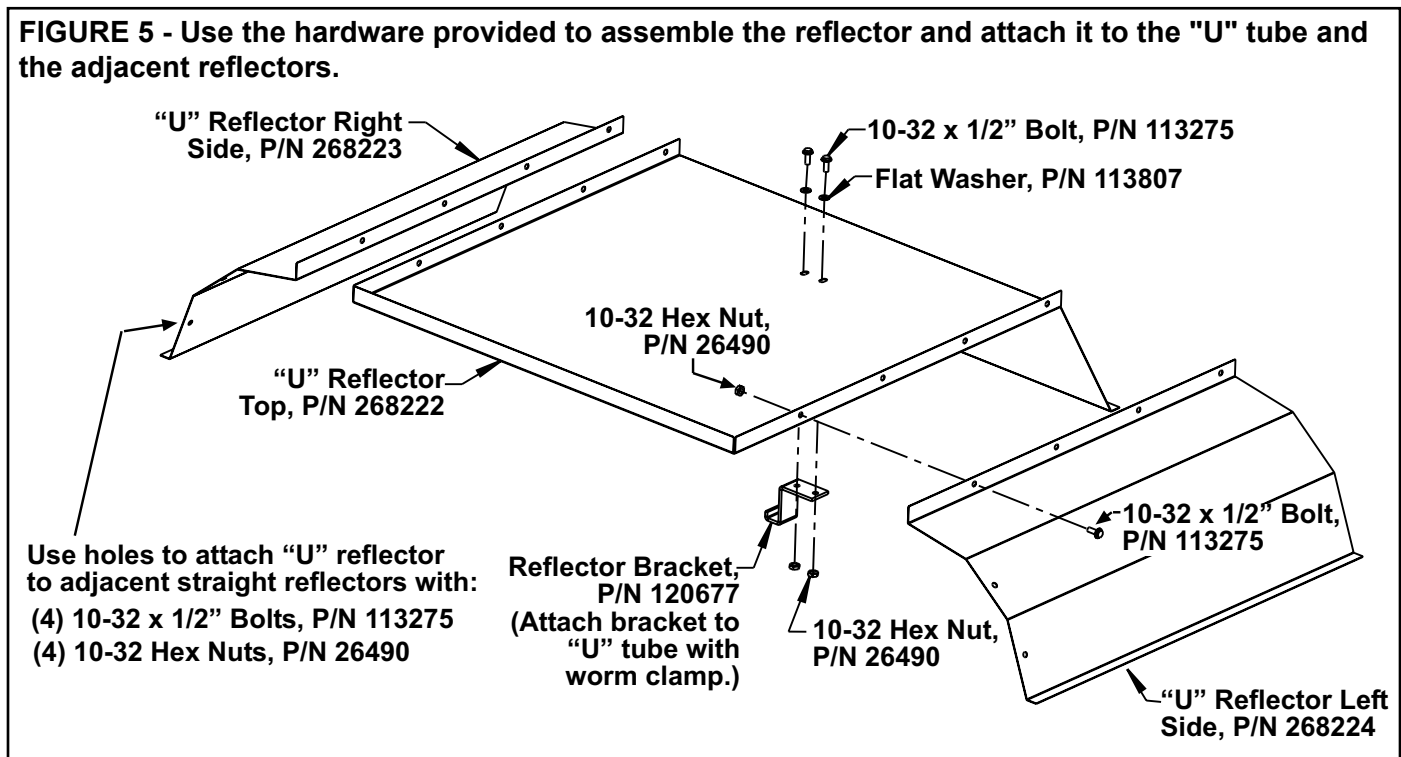

8. **Install the Assembled "U" Tube Reflector** - Position the assembled reflector on top of the "U" tube with the bracket at the center of the bend in the "U". Locate the two holes on the assembled reflector where it overlaps the adjoining straight reflector. Mark the holes on the straight reflector. Remove the "U" reflector assembly and carefully drill 7/32" holes in the straight reflector.

Installation Instructions (cont'd)

Unfasten the worm clamp. Re-position the reflector on top of the tube with the bracket at the center of the "U". Wrap the clamp around the "U" tube attaching the reflector bracket. Fasten the clamp to hold the reflector in place but do not tighten. Use screws and nuts from the kit to attach the side of the "U" tube reflector assembly to the adjacent straight reflector.

Tighten the clamp to secure the reflector to the "U" tube.

Use the clips and screws in the kit to attach the flange of the "U" reflector side to the straight reflector following the same procedure as used when attaching two straight reflectors.

- 9. Install the Next Adjacent Straight Reflector** - Position the reflector in the wire retainer. Mark and drill holes to attach it to the side of the "U" tube reflector. Use screws and nuts from the kit to attach the straight reflector to the "U" tube reflector.

Join the flanges with the clips and screws shipped with the straight tubes and reflectors.

If angled, verify that the end of the retainer wires with the sharper 45° bend are on the lower side.

- 10.** Complete the installation by following the instructions in the heater installation manual.