



OPERATOR MANUAL

IMPORTANT INFORMATION, KEEP FOR OPERATOR

888-994-7636, fax 888-864-7636
unifiedbrands.net

THIS MANUAL MUST BE RETAINED FOR FUTURE REFERENCE. READ, UNDERSTAND AND FOLLOW THE INSTRUCTIONS AND WARNINGS CONTAINED IN THIS MANUAL.

FOR YOUR SAFETY Do not store or use gasoline or other flammable vapors and liquids in the vicinity of this or any other appliance.

NOTIFY CARRIER OF DAMAGE AT ONCE It is the responsibility of the consignee to inspect the container upon receipt of same and to determine the possibility of any damage, including concealed damage. Randell suggests that if you are suspicious of damage to make a notation on the delivery receipt. It will be the responsibility of the consignee to file a claim with the carrier. We recommend that you do so at once.

Manufacture Service/Questions 888-994-7636.

This manual provides information for:

PHHC-26 HOT HOLDING CABINET



RETAIN THIS MANUAL FOR FUTURE REFERENCE

NOTICE: Due to a continuous program of product improvement, Randell reserves the right to make changes in design and specifications without prior notice.

NOTICE: Please read the entire manual carefully before installation. If certain recommended procedures are not followed, warranty claims will be denied.

MODEL NUMBER _____

SERIAL NUMBER _____

INSTALLATION DATE _____

The serial number is located on the interior side wall of the cabinet. An example is shown here.

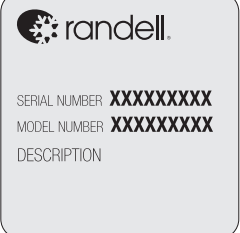

EQUIPMENT DESCRIPTION

MODEL	LENGTH	DEPTH	HEIGHT	# PIZZA BOXES (TWO FRONT TO BACK)	VOLT	AMPS	NEMA	SHIP WT (LBS)
PHHC-26	25"	33"	72"	36	115/1/60	9.7	5-15P	325

INSTALLATION

WARNING: FAILURE TO FOLLOW INSTALLATION GUIDELINES AND RECOMMENDATIONS MAY VOID THE WARRANTY ON YOUR UNIT.

SELECTING A LOCATION FOR YOUR NEW UNIT

The following conditions should be considered when selecting a location for your unit:

- Floor Load:** The area on which the unit will rest must be level, free of vibration, and suitably strong enough to support the combined weights of the unit plus the maximum product load weight.
- Clearance:** There must be a combined total of at least 6" clearance above the top of the unit and also around each side of the top of the unit.
- Ventilation:** Avoid placing your unit in enclosed locations with low ceiling height..

INSTALLATION CHECKLIST

WARNING: DAMAGE TO EQUIPMENT MAY RESULT IF NOT FOLLOWED. RANDELL IS NOT RESPONSIBLE FOR DAMAGE TO EQUIPMENT IF IMPROPERLY INSTALLED.

NOTE: ALL MOTORS ARE OILED AND SEALED.

After the final location has been determined, refer to the following checklist prior to start-up:

- Check to ensure no damage has been sustained to the unit during shipment.
- Check that fan motor and blade rotate freely without striking any stationary members.
- Unit must be properly leveled; check all legs or casters to ensure they all are in contact with the floor while maintaining a level work surface. Adjusting bullet feet heights or shimming casters may be necessary if the floor is not level.



Information contained in this document is known to be current and accurate at the time of printing/creation. Reference our product line website for the most updated product information and specifications. © 2023 Electrolux Professional, Inc. All Rights Reserved.

4. Check all doors to ensure that they are sealing properly, are properly aligned, and open and shut freely.
5. Confirm there is adequate supply voltage for the unit.
6. Plug in unit and turn on main on/off power switch.
7. Allow unit time heat to temperature. If temperature adjustments are required, the temperature adjustment control is located on the face of the unit above the door.
8. Refer to the front of this manual for serial number location. Please record this information in your manual. It will be necessary when ordering replacement parts or requesting warranty service.
9. Confirm that the unit is holding temperature. Set control to desired temperature for your particular ambient and altitude.
10. Allow your unit to operate for approximately 2 hours before putting in product to allow interior of unit to heat to storage temperature.



Figure A

ELECTRICAL SUPPLY

The wiring should be done by a qualified electrician in accordance with local electrical codes. A properly wired and grounded outlet will assure proper operation. Please consult the data tag attached to the compressor to ascertain the correct electrical requirements. Supply voltage and amperage requirements are located on the serial number tag located inside the unit on the left interior side wall.

CABINET DOORS

The doors on the PHHC-26 are reversible. The doors can be reversed by removing the hinge screws located on the opposite side of the cabinet opening. The smaller half size doors need to be rotated 180° and then secured into the screw holes on the opposite side.

This same procedure can be followed for the full size door. In addition the hinges that attach to the full size door will also need to be rotated 180° along with the door latch. The cam lift hinge bushing within the cabinet mounted hinges will need to be removed and inserted into the hinge to allow for proper pitch for door closure.

SHELVES

Cabinet shelves are adjustable in 1" increments. To adjust shelving the shelf will need to be removed. Remove all 4 clips for the shelf and set all 4 at the new desired height making certain all 4 clips are at the same level. Re-install shelf onto the clips.

OPERATION

WARNING: EVEN THOUGH YOUR REACH-IN WAS DESIGNED FOR HEAVY USE, EXCESSIVE AND UNNECESSARY DOOR OPENINGS SHOULD BE AVOIDED IN ORDER TO MAINTAIN PROPER BOX TEMPERATURE.

NOTE: THE HEATED CABINET IS DESIGNED AS A HOLDING CABINET AND WILL MAINTAIN A TEMPERATURE RANGE OF 70° - 180°F. THE HEATED CABINET IS NOT INTENDED TO COOK OR HEAT PRODUCT. PRODUCT ENTERING THE CABINET SHOULD ENTER AT A MINIMUM OF 140°F.

Your heated holding unit will maintain proper temperatures when utilized properly. It is strongly recommended that the doors be kept closed as much as possible. Make sure the doors close properly after each use.

Your heated reach in unit was equipped with a temperature adjustment control located on the top front of the unit. See Figure A. The temperature control has been preset at the factory. Once the unit is powered on, allow 45 minutes to 1 hour for the inside temperature to reach the factory set point of 160°F. Once the unit has reached the set point it may then be loaded with product.

TEMPERATURE CONTROL SETTINGS

PART NO.	RANDELL CONTROL SETTINGS / PHHC-26	REF. NO DEF.
RF CNT1001	XR01CX-4N4LQ Heated Upright Cabinet	1001

CODE	LOCKED	FACTORY SET PARAMETER
Set	Thermostat set point	160
HY	Thermostat Differential (hysteresis)	5
LS	Lower Set Point	150
US	Upper Set Point	180
ot	Offset Room Temp	0
od	Output delay @ Startup	0
AC	Anti-Cycle Time (min off after cycle)	0
CY	Compressor ON time (probe failure)	0
Cn	Compressor OFF (probe failure)	0
CH	Kind of Action (Heating or Cooling)	Ht
CF	°C / °F	F
rE	Resolution 0.0°C (only °C)	in
dy	Display Delay	0
ALC	Alarm Configuration	Ab
AU	Maximum Temperature Alarm	190
AL	Minimum Temperature Alarm	140
iP	Digital Input Parity	CL
iF	Digital Input Configuration	EA
di	Digital Input Delay	5
dC	Comp. and Fan Status when open door	no
rd	Regulation with door open	n
PC	Type of Probe	ntc
rL	Software Info	1.7
Pt	Software info	12

ENTERING CONTROLLER PROGRAM MODE

1. Enter the Programming mode by pressing the “Set” and ▼ Arrow for 3 seconds. (the Fahrenheit symbol “F” will start blinking)

NOTE: If “of” appears the control is locked. Proceed to Unlocking the Keyboard to unlock.

2. Enter full programming mode by again pressing the “Set” and ▼ Arrow for 8 seconds until L2 appears. Release the buttons and “HY” will appear with a decimal point between the “H” and “Y” at the bottom. This indicates the control is now in full programming mode.
3. While “HY” is on display push ▲ once and release.
4. “LS” will appear on display (this is the low set point)
5. Push and release “SET” once to view the current LS set point.
6. Continue this procedure of pushing “Set” and releasing to see the next code on the sheet and the corresponding parameter for that code.
7. Should a parameter need to be changed you may use the ▼ or ▲ to get to the desired new parameter.
8. Once the desired new parameter setting is achieved push and release “SET” once. The new parameter will flash 3 times indicating the new parameter is locked in.
9. After the parameter is locked in the control will then drop to the next code on the chart. Continue by pushing the “Set” button to view the parameter of that code.
10. Proceed until you have reached “HY” again.
11. Do not push any buttons for 8 seconds.
12. Once the temperature is displayed on the control you are now out of programming mode,
13. You may now lock the keyboard if desired. Proceed to How to Lock the Keyboard.

UNLOCKING THE KEYBOARD

1. Keep pressed together for more than 3 seconds the ▲ and ▼ keys until the “on” message will be displayed.

LOCKING THE KEYBOARD

1. Keep pressed for more than 3 seconds the ▲ and ▼ keys.
2. The “of” message will be displayed and the keyboard will be locked. At this point it will be possible only to see the set point or the **MAX** or **Min** temperature stored.
3. If a key is pressed more than 3 seconds the “of” message will be displayed.

NOTE: Do not change parameters of control without consulting with Randell Technical Support – 1.800.621.8560. Option 3.

PREVENTIVE MAINTENANCE

WARNING: DO NOT USE SHARP UTENSILS AND/OR OBJECTS.

WARNING: DO NOT USE STEEL PADS, WIRE BRUSHES, SCRAPERS, OR CHLORIDE CLEANERS TO CLEAN YOUR STAINLESS STEEL.

CAUTION: DO NOT USE ABRASIVE CLEANING SOLVENTS, AND NEVER USE HYDROCHLORIC ACID (MURIATIC ACID) ON STAINLESS STEEL.

Randell strongly suggests a preventive maintenance program which would include the following procedures:

1. Clean all gaskets on a **weekly** basis with a solution of warm water and a mild detergent to extend gasket life.
2. Wipe out any debris that has fallen into the cabinet on a **daily** basis.
3. Clean fan blades on a **quarterly** basis. It is recommended this be performed by an authorized service agent.

Recommended cleaners for your stainless steel include the following:

JOB	CLEANING AGENT	COMMENTS
Routine cleaning	Soap, ammonia, detergent Medallion	Apply with a sponge or cloth
Fingerprints and smears	Arcal 20, Lac-O-Nu, Ecoshine	Provides a barrier film
Stubborn stains and discoloration	Cameo, Talc, Zud, First Impression	Rub in the direction of the polish lines
Greasy and fatty acids, blood, burnt-on foods	Easy-Off, Degrease It, Oven Aid	Excellent removal on all finishes
Grease and Oil	Any good commercial detergent	Apply with a sponge or cloth
Restoration/Preservation	Benefit, Super Sheen	Good idea monthly

Reference: Nickel Development Institute, Diversey Lever, Savin, Ecolab, NAFEM

REPLACEMENT PARTS

To order parts, contact your Authorized Service Agent. Supply the model designation, serial number, part description, part number, quantity, and when applicable, voltage and phase.

CONTACT US

If you have questions pertaining to the content in this manual, contact Randell at 888-994-7636.

TROUBLESHOOTING

This unit is designed to operate smoothly and efficiently if properly maintained. However, the following is a list of checks to make in the event of a problem. Wiring diagrams are found at the end of this manual. When in doubt, turn unit off and contact service at 888-994-7636.

SYMPTOM	POSSIBLE CAUSE	PROCEDURE
Unit doesn't heat	No power to unit	Plug in unit
	Temperature control turned off	Check temperature control
	Temperature control faulty	Test temperature control
	High limit device	Test high limit
	Heating element faulty	Test element
Control Error	Flashing HA	Unit too hot / check probe
	Flashing LA	Unit too cool / check door closure
	Flashing P1	Check probe connection
Unit too hot	Temperature control too high	Adjust temperature control
	Temperature control	Test temperature control
Unit not hot enough	Door not sealing	Inspect gasket & door hinges
	Fan motor	Raise temperature setting
	Temperature control	Adjust temperature control
	Element	Test elements

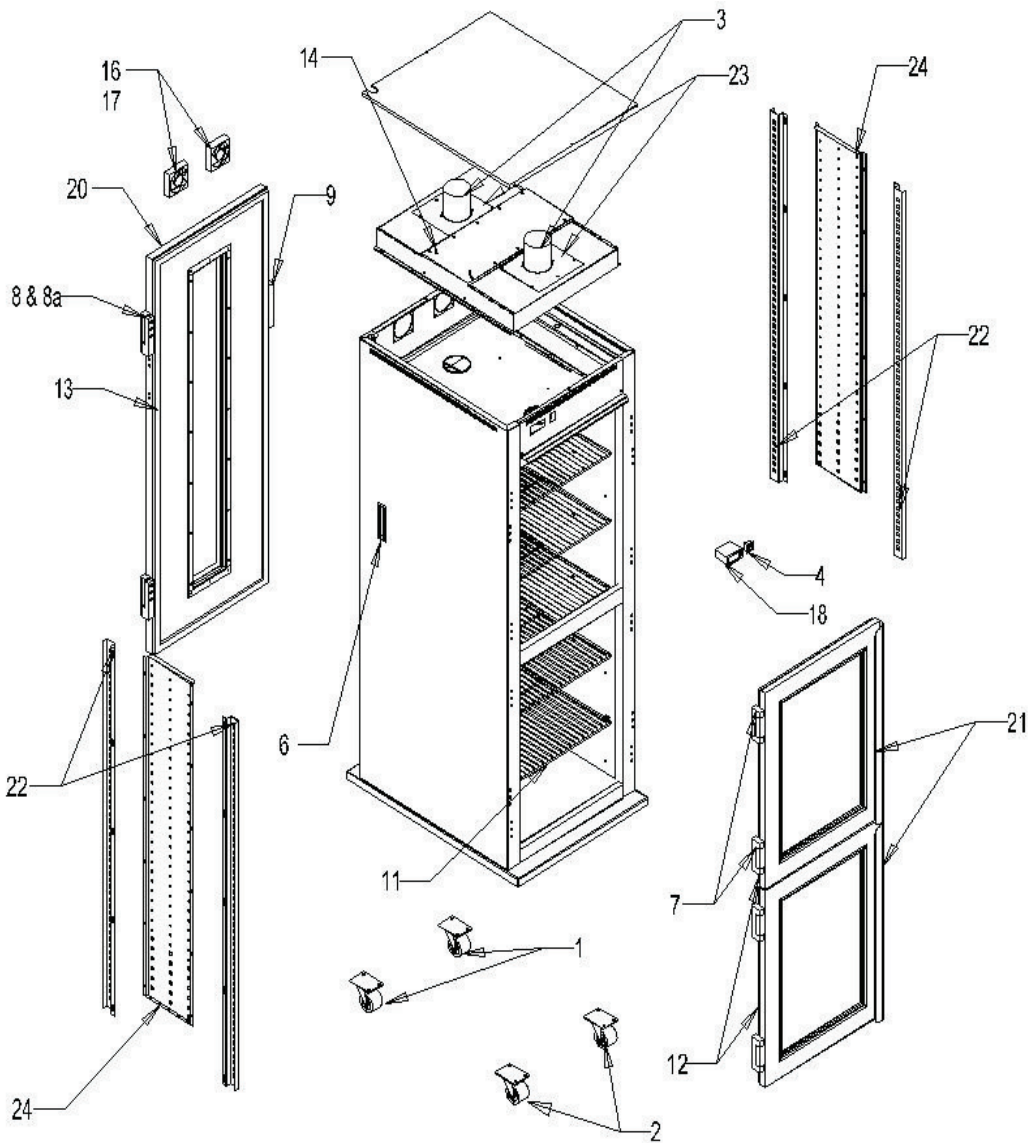

ITEM	PART NUMBER	DESCRIPTION
1	HD CST9802	CASTER, 3.5" SWIVEL W/ BRAKE
2	HD CST1009	CASTER, 3.5" RIGID
3	EL BLW1002	BLOWER ASSY, 115V
4	EL SWT610BE	SWITCH, ILLUMINATED ROCKER
5	HD CLP150	S/S SHELF CLIP
6	HD HDL251	HANDLE, BLACK PLASTIC
7	HD HNG0706	DOOR HINGE, EDGEMOUNT, REAR DOORS
8	HD HIN0001	DOOR HINGE, KASON, FRONT DOOR
8A	HD HIN0001-5	DOOR HINGE, CAM LIFT BUSHING (LARGE DOOR)
9	HD LCH1006	DOOR HANDLE/LATCH, FRONT DOOR
10	HD RCK1001	S/S RACK, 9.25" X 26.9" / FAN GUARD
11	HD SHL1004	S/S SHELF, 18" X 26.25"
12	IN GSK1012	GASKET, 21.77" X 59.84" SNAP IN
13	IN GSK1011	GASKET, 21.77" X 29.65" SNAP IN
14	EL ELM1100	ELEMENT, 120V, 1100W
15	EL WIR461-90	POWER CORD, 9' 16/3 W/ 90° PLUG
16	RF FAN1002	FAN, AXIAL 115V/60HZ
17	RF FAN1003	WIRE FAN GUARD FOR RF FAN1002
18	RP CNT1100	CONTROL, DIXELL XR01CX W/ PROBE
19	RF CNT0505	PROBE, FOR DIXELL CONTROL
20	RP DOR1100	DOOR ASSY, FULL SIZE, OPERATOR SIDE
21	RP DOR1101	DOOR ASSY, 1/2 SIZE, CUST SIDE
22	RP PIL1100	PILASTER, ONE PIECE (NOT SET OF 4)
23	RP SHD1100	FAN SHROUD ENCLOSURE
24	RP DCT1100	VERTICAL AIR DUCT

