



OPERATOR MANUAL

IMPORTANT INFORMATION, KEEP FOR OPERATOR

888-994-7636, fax 888-864-7636
unifiedbrands.net

THIS MANUAL MUST BE RETAINED FOR FUTURE REFERENCE. READ, UNDERSTAND AND FOLLOW THE INSTRUCTIONS AND WARNINGS CONTAINED IN THIS MANUAL.

FOR YOUR SAFETY Do not store or use gasoline or other flammable vapors and liquids in the vicinity of this or any other appliance.

NOTIFY CARRIER OF DAMAGE AT ONCE It is the responsibility of the consignee to inspect the container upon receipt of same and to determine the possibility of any damage, including concealed damage. Randell suggests that if you are suspicious of damage to make a notation on the delivery receipt. It will be the responsibility of the consignee to file a claim with the carrier. We recommend that you do so at once.

Manufacture Service/Questions 888-994-7636.

This manual provides information for:

BLAST CHILLERS BC-918RI, BC-510WT, BC-003UC



BC-003UC

BC-510WT

BC-918RI

RETAIN THIS MANUAL FOR FUTURE REFERENCE

NOTICE: Due to a continuous program of product improvement, Randell reserves the right to make changes in design and specifications without prior notice.

NOTICE: Please read the entire manual carefully before installation. If certain recommended procedures are not followed, warranty claims will be denied.

MODEL NUMBER _____

SERIAL NUMBER _____

INSTALLATION DATE _____

The serial number is located on the interior rear wall of the Blast Chiller.



SERIAL NUMBER XXXXXXXXX
MODEL NUMBER XXXXXXXXX
DESCRIPTION

EQUIPMENT DESCRIPTION

Model No.	Body Style	Length	Depth	Height	Pan Capacity (12" x 20" x 2.5")	Pan Capacity (18" x 26")	NEMA	BTU Requirements for Remote Installations	HP	Approx. Weight
BC-003UC	Undercounter	27"	30"	35"	3	-	5-20P	5400 @ 20F Evap Temp	1/2	320
BC-510WT	Worktop	59"	34"	36"	10	5	5-20P	6050 @20F Evap Temp	3/4	565
BC-918RI	Upright	40"	38.7"	71"	18	9	L14-20P	12100 @ 20F Evap Temp	1-1/2	858



Information contained in this document is known to be current and accurate at the time of printing/creation. Reference our product line website for the most updated product information and specifications. © 2024 Electrolux Professional, Inc. All Rights Reserved.

INSTALLATION

SELECTING A LOCATION FOR YOUR NEW UNIT

The following conditions should be considered when selecting a location for your unit:

1. **Floor Load:** The area on which the unit will rest must be level, free of vibration, and suitably strong enough to support the combined weights of the unit plus the maximum product load weight. All casters or legs must be in contact with the floor to support the weight. Legs have adjustable feet that can be raised or lowered. Casters may require shims in order for the caster to be in contact with the floor. **NOTE:** If there is a question pertaining to weight load limits, consult the factory at 1-888-994-7636.
2. **Ventilation:** The air-cooled self-contained unit requires a sufficient amount of cool clean air. Avoid surrounding your blast chiller around other heat generating equipment and out of direct sunlight. Also, avoid locating in an unheated room or where the room temperature may drop below 55° F (13°C) or above 86°F (32°C).
3. **Clearance:** There must be a combined total of at least 3" clearance on all sides of the unit.

INSTALLATION CHECKLIST

After the final location has been determined, refer to the following checklist prior to start-up:

1. Check all exposed refrigeration lines to ensure that they are not kinked, dented, or rubbing together.
2. Check that the condenser and evaporator fans rotate freely without striking any stationary members.
3. Turn on control once unit has been plugged in or properly wired direct (see page 15)
4. Allow unit time to cool down to holding temperature. (See page 10 for Unit Operation).
5. Refer to the front of this manual for serial number location. Please record this information in your manual on page 3 now. It will be necessary when ordering replacement parts or requesting warranty service.
6. Confirm that the unit is holding temperature.
7. Allow your unit to operate for approximately 30 minutes before putting in food to allow interior of unit to cool down to storage temperature.

NOTE: All motors are oiled and sealed.

NOTE: FAILURE TO FOLLOW INSTALLATION GUIDELINES AND RECOMMENDATIONS MAY VOID THE WARRANTY ON YOUR UNIT.

ELECTRICAL SUPPLY

The wiring should be done by a qualified electrician in accordance with local electrical codes. A properly wired and grounded outlet will assure proper operation. Please consult the data tag attached to the compressor to ascertain the correct electrical requirements. Supply voltage and amperage requirements are located on the serial number tag located on the rear interior wall.

NOTE: It is important that a voltage reading be made at the compressor motor electrical connections, while the unit is in operation to verify the correct voltage required by the compressor is being supplied. Low or high voltage can detrimentally affect operation and thereby void its warranty.

NOTE: It is important that your unit has its own dedicated line. Condensing units are designed to operate with a voltage fluctuation of plus or minus 10% of the voltage indicated on the unit data tag. Burn out of a condensing unit due to exceeding voltage limits will void the warranty.

OPERATION

The Randell BC series blast chillers are designed for rapid chilling through the danger zone down to 40°F or below in approximately 90 minutes. The exact chill time will vary depending on product type. The door must be in closed position to activate switch at top of door before any cooling cycle will begin.

INTRODUCTION

1. The control software for the BC Control Unit is based on a Real-Time Operating System and is capable of simultaneously running a chiller operation while at the same time accepting/displaying user information from the control panel such as chiller preset adjustments. This document provides an overview of the current controller features.

POWERING UP UNIT

1. Once the unit is connected to AC power the touch screen will display a loading screen with a progress bar.
2. Once loaded the standby screen will be displayed. Depressing the power key on initial power up will cause the unit to request setting of the date and time. Adjust the date and time values by touching the desired value, press the set button then use arrow buttons to adjust value up or down. After all values have been set press the return button on the bottom right of the screen to return to the standby screen.

SETTING THE DATE/TIME

1. Upon turning on the unit for the first time, the controller will prompt the user to set the current date and time of day.
2. To adjust the date or time after initial power up you must access the Date Set function. This function can be accessed by entering the menu screen from the home screen then the control panel.

Menu → Control Panel → Date Set

POWERING DOWN UNIT

The unit may be returned to the low power standby state by depressing the power button. The display will then return to the standby screen. **NOTE:** Power should only be removed from the unit while it is idle on this standby screen.

MODES OF OPERATION

The controller can run one of three possible modes, Auto, Manual, or Hold.







1. **Auto Mode -** Auto Mode will run a chill cycle until all food probes have reached a preset set point.
 - a. Auto can be manually selected by pressing the "AUTO" button on the home screen.
 - The food probe set point can be modified by entering the setting menu via the "SET" button at the bottom of the auto cycle screen.
 - b. Auto cycle will start automatically from home screen or while running a hold cycle if food probes are placed directly into food product and probes have exceeded 100°F
 - c. Once an auto cycle has completed the unit will perform a defrost cycle. The word defrost will display on the cycle screen once the defrost cycle has activated and will remain until the evaporator coil has properly defrosted.
 - d. After completion of the defrost cycle the unit will hold the cabinet at the hold set point until the user removes the product and ends the chill cycle by pressing the "X" in the lower right-hand corner of the cycle screen.
2. **Manual Mode -** Manual Mode will run a chill cycle for a user set duration that is not controlled by food probe temperature. Chill cycle will only end when set duration has expired or user intervention occurs.
3. **Hold Mode -** Cabinet temperature will be held at a user defined set point. This can be used to pre chill the cabinet prior to an auto/manual chill cycle or temporarily hold food product. Not intended for extended food product storage.

USB FLASH DRIVE

Data stored from previous blast chiller cycles and alarms can be retrieved from the controller's internal memory and sent to a USB flash drive. This makes for a convenient method to transfer blast chiller data to a personal computer. Data is written into a file on the flash drive in a comma delimited form that is suitable for text and spreadsheet applications. A data transfer to a USB drive is initiated as follows:

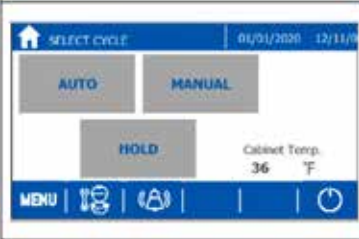
1. Access Control MENU from the home screen.
2. Enter the control panel by pressing Control Panel button.
3. Select Log File Management.
4. Insert USB drive into USB port on front panel of unit.
5. Select file to export and follow prompts.
6. Once complete the door button in bottom right corner of the screen will take you back a page until you get back to the home screen.

QUICK START GUIDE

	<p>Initial screen on unit start up.</p> <p>Pressing the  button will take the unit out of standby mode.</p>
	<p>On initial startup the machine will require a date and time setup.</p> <p>Use arrows and set button to modify values.</p> <p>Once complete press the door icon in the bottom right corner to exit the date and time set page.</p>
	<p>Home screen</p> <p>Select cycle type</p> <p>Auto- Cycle will run until all food probes are to set point temperature.</p> <p>Manual- Cycle will run until a preset duration expires.</p> <p>Hold- Maintains a set cabinet temperature until cycle is ended.</p> <p> Button will put unit into standby when not in use.</p>
	<p>Auto</p> <p>Once food probes are placed in food product close the door and press the start button in the lower right corner of the screen. (Cycle will automatically start if food product is over 100°F)</p> <p>Unit will run until all probes have reached set temperature.</p> <p>After chill cycle is complete the unit will defrost then hold the cabinet temperature at a set temperature until the cycle is stopped by the user.</p> <p>SET menu can be used to modify set points.</p>
	<p>Manual</p> <p>Use SET menu modify set points including desired cycle duration.</p> <p>Once start button is pushed the unit will run a chill cycle for the user set duration regardless of what temperature the product reaches.</p>
	<p>Hold</p> <p>This cycle will maintain a cabinet temperature for temporary storage of food product.</p> <p>SET menu can be used to modify set points.</p>

	<p>HACCP Data Retrieval</p> <ol style="list-style-type: none"> 1. Access Control MENU from the home screen. 2. Enter the control panel by pressing Control Panel button. 3. Select Log File Management. 4. Insert USB drive into USB port on front panel of unit. 5. Select file to export and follow prompts. 6. Once complete the door button in bottom right corner of the screen will take you back a page until you get back to the home screen.
-----------------------------------------------------------------------------------	-----------------------------------------------------------------------------------------------------------------------------------------------------------------------------------------------------------------------------------------------------------------------------------------------------------------------------------------------------------------------------------------------------------------------------------------------------------------------------------------------------------------------------------------------

MAINTENANCE

<p>WARNING: DO NOT USE SHARP UTENSILS AND/OR OBJECTS.</p> <p>WARNING: DO NOT USE STEEL PADS, WIRE BRUSHES, SCRAPERS, OR CHLORIDE CLEANERS TO CLEAN YOUR STAINLESS STEEL.</p> <p>CAUTION: DO NOT USE ABRASIVE CLEANING SOLVENTS, AND NEVER USE HYDROCHLORIC ACID (MURIATIC ACID) ON STAINLESS STEEL.</p> <p>WARNING: DO NOT PRESSURE WASH EQUIPMENT AS DAMAGE TO ELECTRICAL COMPONENTS MAY RESULT.</p>

Randell strongly suggests a preventive maintenance program which would include the following monthly procedures:

NOTE: When cleaning the interior cabinet place unit into standby mode to prevent door alarm from becoming active.

MONTHLY PM PROCEDURES

1. Cleaning of all condenser coils. Condenser coils are a critical component in the life of the compressor and must remain clean to assure proper air flow and heat transfer. Failure to maintain this heat transfer will affect unit performance and eventually destroy the compressor. Clean the condenser coils with coil cleaner and/or a vacuum, cleaner and brush. **NOTE:** Brush coil in direction of fins, normally vertically as to not damage or restrict air from passing through condenser.
2. Clean fan blade on the condensing unit.
3. Clean and disinfect drains with a solution of warm water and mild detergent.
4. Clean and disinfect drain lines and evaporator pan with a solution of warm water and mild detergent.
5. Clean all gaskets on a weekly if not daily basis with a solution of warm water and a mild detergent to extend gasket life.

RECOMMENDED CLEANERS FOR YOUR STAINLESS STEEL INCLUDE THE FOLLOWING:

JOB	CLEANING AGENT	COMMENTS
Routine cleaning	Soap, ammonia, detergent Medallion	Apply with a sponge or cloth
Fingerprints and smears	Arcal 20, Lac-O-Nu, Ecoshine	Provides a barrier film
Stubborn stains and discoloration	Cameo, Talc, Zud, First Impression	Rub in the direction of the polish lines
Greasy and fatty acids, blood, burnt-on foods	Easy-Off, Degrease It, Oven Aid	Excellent removal on all finishes
Grease and Oil	Any good commercial detergent	Apply with a sponge or cloth
Restoration/Preservation	Benefit, Super Sheen	Good idea monthly

Reference: Nickel Development Institute, Diversy Lever, Savin, Ecolab, NAFEM

Proper maintenance of equipment is the ultimate necessity in preventing costly repairs. By evaluating each unit on a regular schedule, you can often catch and repair minor problems before they completely disable the unit and become burdensome on your entire operation.

For more information on preventive maintenance, consult your local service company or CFESA member. Most repair companies offer this service at very reasonable rates to allow you the time you need to run your business along with the peace of mind that all your equipment will last throughout its expected life. These services often offer guarantees as well as the flexibility in scheduling or maintenance for your convenience. For a complete listing of current Randell ASA please visit www.unifiedbrands.net.

Randell believes strongly in the products it manufactures and backs those products with one of the best warranties in the industry. We believe with the proper maintenance and use, you will realize a profitable return on your investment and years of satisfied service.

REPLACEMENT PARTS

To order parts, contact your Authorized Service Agent. Supply the model designation, serial number, part description, part number, quantity, and when applicable, voltage and phase.

CONTACT US

If you have questions pertaining to the content in this manual, contact Randell at 888-994-7636.

ALARMS

ALARM CODE	DESCRIPTION	POSSIBLE CAUSE
RPF	Room probe failure	Open cabinet air temperature probe circuit. Caused by faulty probe, broken wire, or bad connection.
EPF	Evaporator probe failure	Open evaporator temperature probe circuit. Caused by faulty probe, broken wire, or bad connection.
NPF	Needle probe failure	Open needle probe circuit. Caused by faulty probe, faulty receptacle, broken wire, or bad connection.
RHT	Cabinet temperature too high	Refrigeration system not cooling. Faulty/inaccurate cabinet air temperature probe.
RLT	Cabinet temperature too low	Control relay stuck closed. Faulty/inaccurate cabinet air temperature probe.
PWF	Power failure during cycle	Unit unintentionally unplugged during use.
CTE	Maximum cycle time expired	Running multiple batches on single cycle. Faulty needle probe preventing cycle from ending.
DOOR	Door alarm	Door open for extended amount of time. Ensure unit is in standby if door is intentionally left open for extended amounts of time during cleaning.
ACF	General configuration error	Corrupted software Contact Randell Tech Services

TROUBLESHOOTING

This unit is designed to operate smoothly and efficiently if properly maintained. However, the following is a list of checks to make in the event of a problem. Wiring diagrams are found at the end of this manual. When in doubt, turn unit off and contact service at 888-994-7636 or tsrandell@unifiedbrands.net.

SYMPTOM	POSSIBLE CAUSE	PROCEDURE
Unit doesn't pre-chill	1. No power to unit 2. Unit in standby mode 3. Dirty Condenser Coil 4. Refrigeration system fault	1. Check power source 2. Check power switch 3. Clean condenser coil 4. Call ASA for service
AUTO mode ends but product is not at temp	1. Probe location 2. Probe faulty	1. Relocate probe to center mass of product 2. Test probes in ice bath to see if displayed value is within +/- 2°F 3. Call ASA for service
AUTO mode ends and product is frozen	1. Probe location 2. Probe faulty	1. Relocate probe to center mass of product 2. Test probes in ice bath to see if displayed value is within +/- 2°F 3. Replace probe
Freezing product or product not cold enough	1. Probe location 2. Improper set point 3. Faulty cabinet air probe.	1. Clean probes 2. Test probes in ice bath to see if displayed value is within +/- 2°F 3. Check probe receptacle for any damage 4. Validate set point value
Moisture around drawer or frame	1. Gasket not sealing 2. Gasket torn	1. Adjust gasket 2. Replace gasket
Ice in drain pan or water in bottom of unit or floor	1. Drain tube clogged 2. Unit not level	1. Clean drain 2. Adjust leveling leg/shim casters

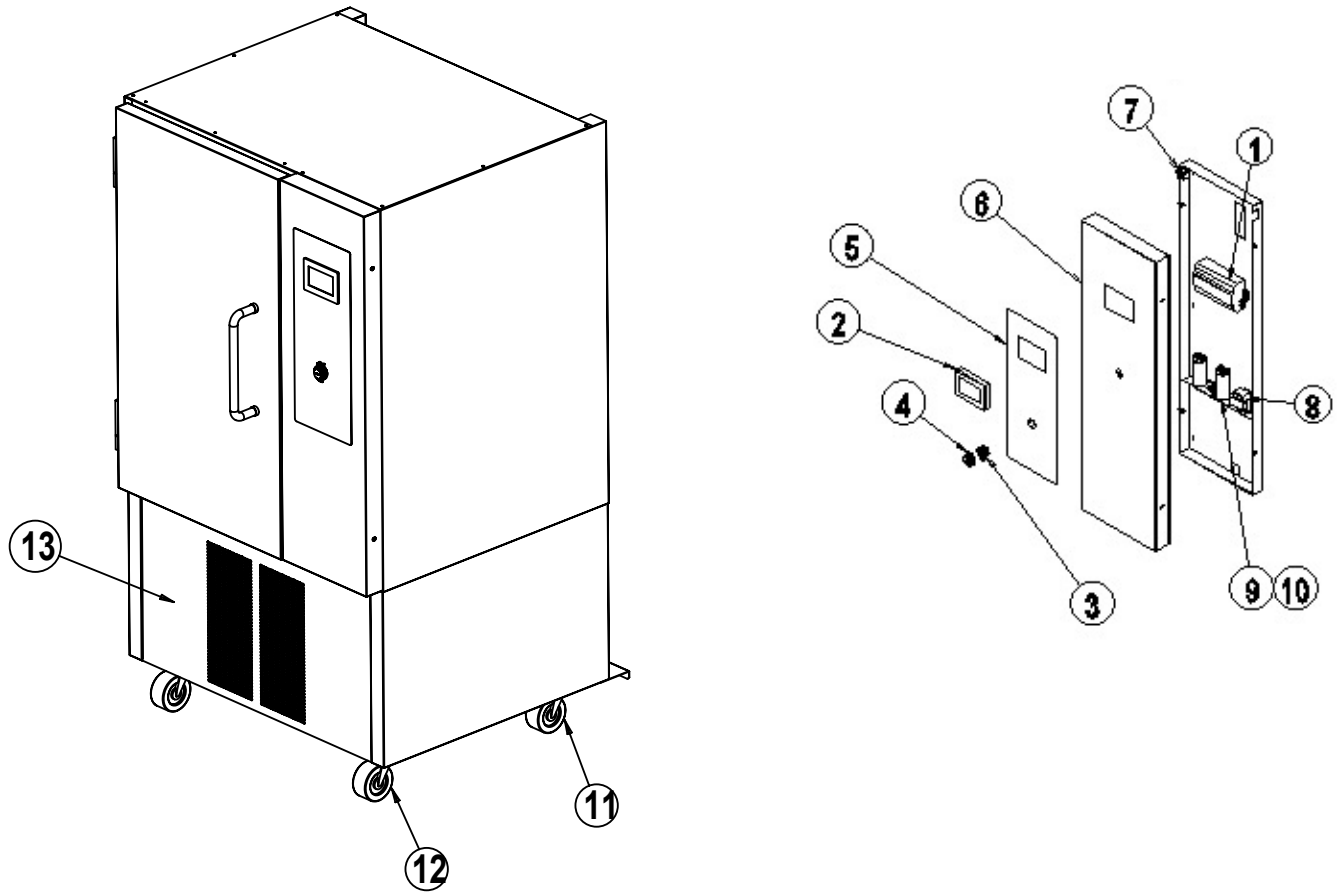

ITEM	PART NUMBER	DESCRIPTION	BC-918RI	BC-510WT	BC-003UC
1	RF CNT1707	CONTROL, XB887D	X	X	X
2	RF CNT1708	CONTROL, TOUCHSCREEN	X	X	X
3	EL CNT1901	USB CONNECTOR	X	X	X
4	EL CNT1902	USB CONNECTOR CAP	X	X	X
5	PP STK1902	LABEL, FRONT PANEL CONTROL SURROUND	X	X	
6	RP PNL2102	CONTROL PANEL, BC-918, LEFT HAND	X		
7	EL SWT9901	SWITCH, BLAST CHILLER DOOR	X	X	
8	EL TRN0304	TRANSFORMER, 120V:24V 40VA 599 CLASS II	X	X	X
9	RF CAP1101	CAPACITOR, 14MFD 440VAC, PN-450-20-0148	X		
9A	RF CAP2202	CAPACITOR, 14MFD	X		
10	RF CAP1201	BOOT, NEOPRENE RUBBER FOR RF CAP1101	X		
11	HD CST200	CASTER, 5.5" OA, W/O BRAKE	X	X	X
12	HD CST201	CASTER, 5.5" OA, WITH BRAKE	X	X	X
13	RP LVR1401	LOUVER, BC-918RI	X		
14	EL BEP1901	BUZZER, PUI AUDIBLE	X		
NS	RF CNT1709	CONTROL, CONNECTOR KIT	X	X	X
NS	EL WIR1901	USB CABLE, CONTROL TO USB CONNECTOR	X	X	X
NS	HD LEG9902	LEG, PRE-ASSEMBLED - OPTIONAL	X	X	X
NS	RP PNL2103	CONTROL PANEL, BC-918, RIGHT HAND	X		
NS	HD RCK0601SS	UNIVERSAL PAN SLIDE, S/S	X	X	

NS = NOT SHOWN

**BC-918RI
DOOR ASSEMBLY**

CALL FACTORY FOR REPLACEMENT PARTS:
888-994-7636

Parts List

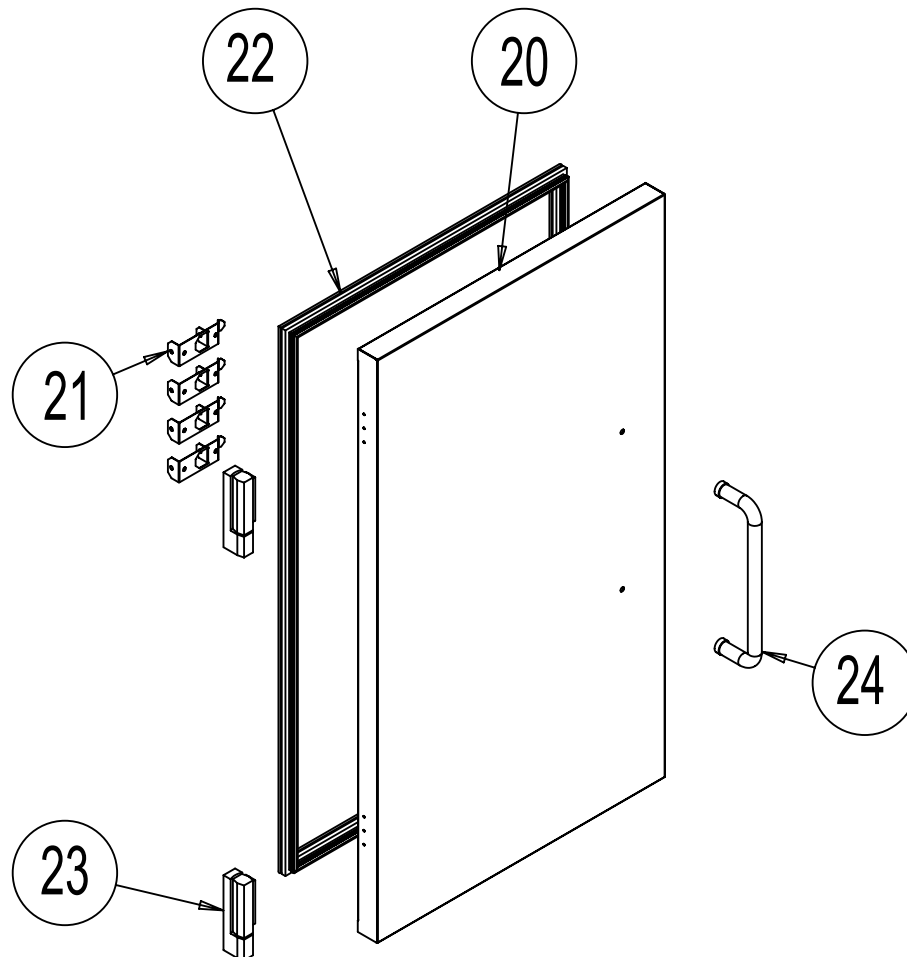

ITEM	PART NUMBER	DESCRIPTION	BC-918RI	BC-510WT	BC-003UC
20	RP DOR1402	REFRIGERATED DOOR ASSEMBLY, LEFT HINGE	X		
21	RP PRB1101	FOOD PROBE HOLDER	X	X	X
22	IN GSK9904	GASKET, 24.25 X 41.41 BC 20 NC10492	X		
23	RP HIN0001	HINGE, ADJUSTABLE REACH IN	X		
24	HD HDL1101	HANDLE, HEAVY DUTY TUBULAR, SATIN FINISH	X		
NS	EL WIR0222	WIRE, FOOD PROBE EXT	X	X	X
NS	EL WIR0223	WIRE, DOOR SWITCH EXT	X	X	X
NS	HD PRB0202	FOOD PROBE, WHITE	X	X	X
NS	HD PRB1903	FOOD PROBE, RED	X		
NS	HD PRB1904	FOOD PROBE, GREEN	X	X	
NS	HD PRB1905	FOOD PROBE, BLACK	X		
NS	RP DOR1401	REFRIGERATED DOOR ASSEMBLY, RIGHT HINGE	X		

NS = NOT SHOWN

**BC-918RI
CONDENSING UNIT**

CALL FACTORY FOR REPLACEMENT PARTS:
888-994-7636

Parts List

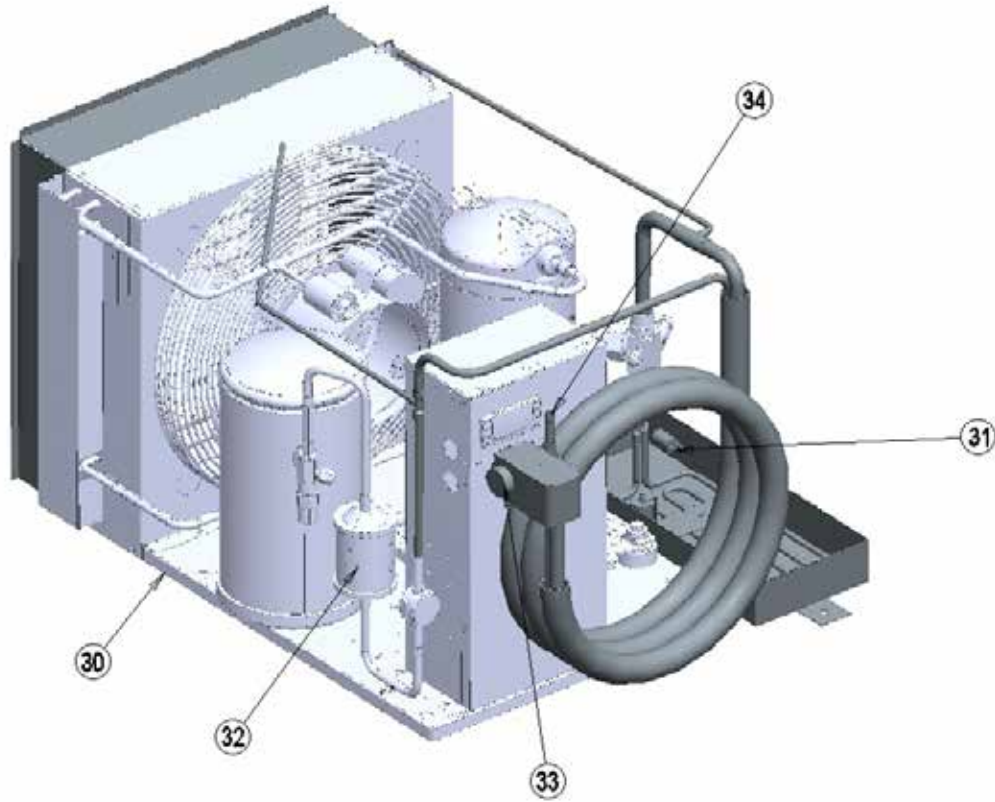

ITEM	PART NUMBER	DESCRIPTION	BC-918RI	BC-510WT	BC-003UC
30	RF CON151S	COND UNIT, 1.5HP 230V	X		
31	EL WIR274-220	CONDENSATE HEATER ELEMENT	X		
32	RF FLT376	FILTER DRYER, 3/8"	X		
33	RF COI003	COIL, SOLENOID DANFOSS 120V	X	X	
34	RF VLV005	VALVE, LIQUID LINE SOLENOID	X	X	
NS	EL WIR0226	WIRE, AC POWER INPUT CABLE	X		
NS	EL BRK9906	BREAKER, 2 POLE 20 AMP	X		
NS	EL WIR470-14	POWER CORD, 14GA 2' MALE	X		

NS = NOT SHOWN

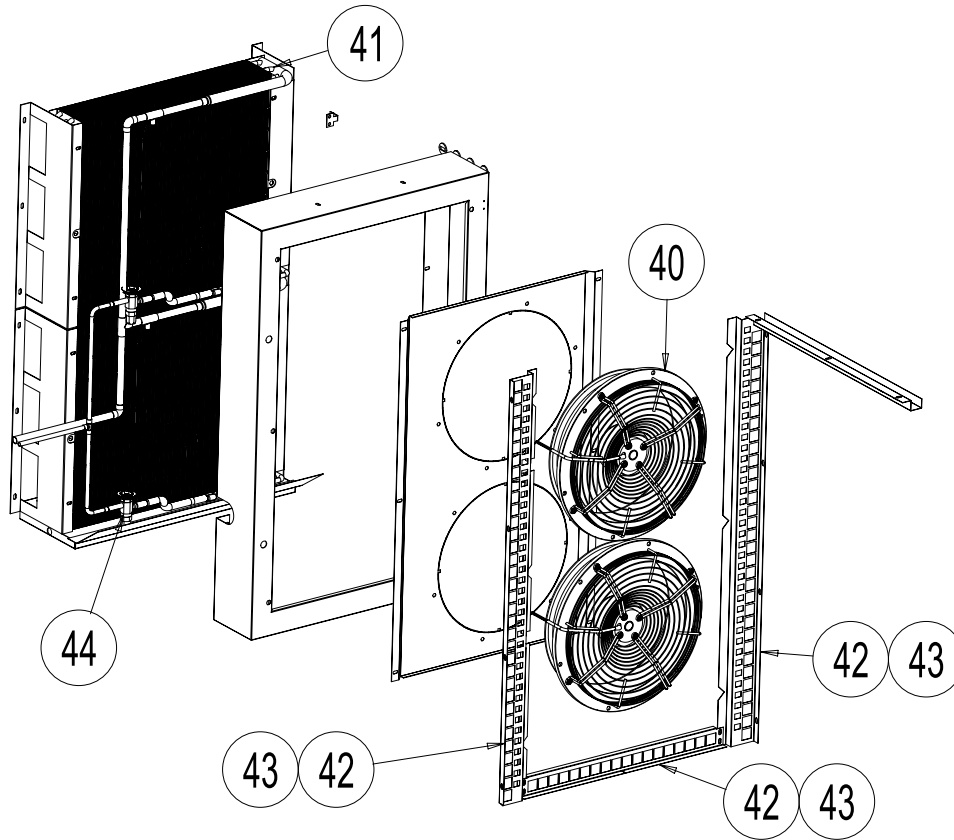

ITEM	PART NUMBER	DESCRIPTION	BC-918RI	BC-510WT	BC-003UC
40	RF FAN1902	FAN, AXIAL, 315mm DIA, 120V, WITH CORD	X		
41	RF COI1803	COIL, 19x20 BLAST CHILLER	X	X	
42	RP PIL1401	PILASTER, RACK BRACE, SET OF THREE, HINGED LEFT	X		
43	RP PIL1402	PILASTER, RACK BRACE, SET OF THREE, HINGED RIGHT	X		
44	RF VLV1102	VALVE, EXPANSION	X	X	

NS = NOT SHOWN

Parts List

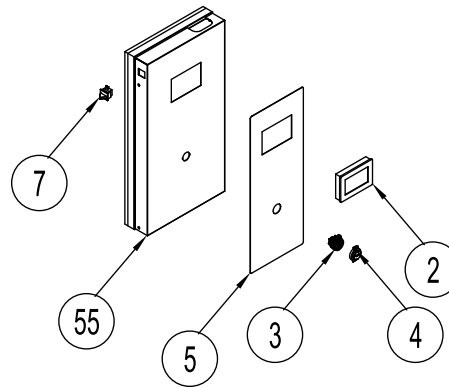
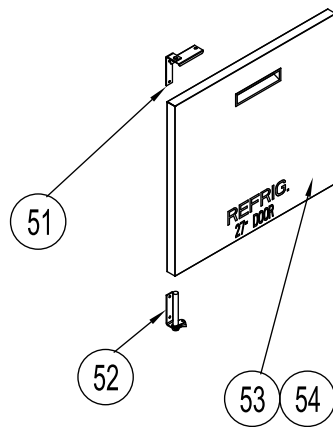
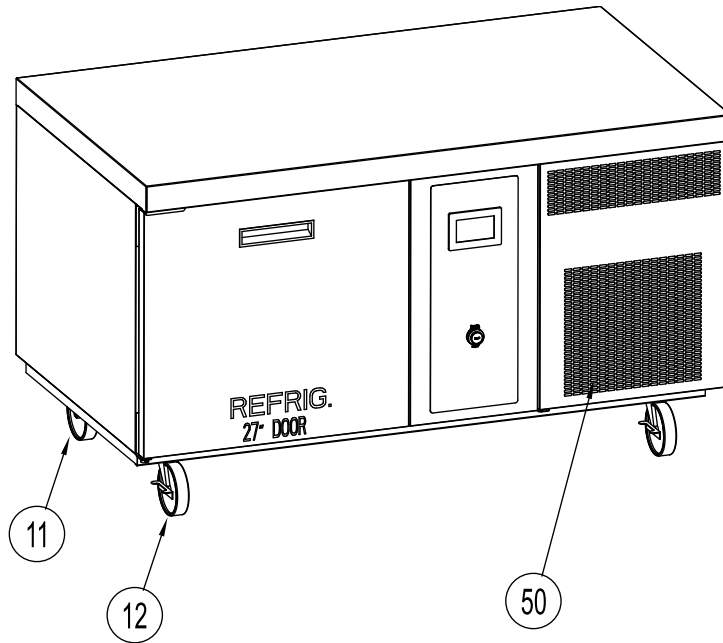

ITEM	PART NUMBER	DESCRIPTION	BC-918RI	BC-510WT	BC-003UC
50	RP LVR1701	LOUVER, BC-510WT		X	
51	RP HNG1701	HINGE, DOOR TOP, 38MM WIDE		X	
52	RP HNG025	HINGE, SPRING LOAD ASSY, SELF-CLOSING		X	
53	RP DOR1602L	DOOR, LH BC-510WT		X	
54	RP DOR1602R	DOOR, RH BC-510WT		X	
NS	IN GSK1025	GASKET, 21.57 X 24.25 PUSH IN		X	
55	RP PNL2104	CONTROL PANEL, BC-510WT LEFT HAND		X	
55A	RP PNL2105	CONTROL PANEL, BC-510WT RIGHT HAND		X	

NS = NOT SHOWN

BC-510WT
EVAP. COIL/CONDENSING UNIT
 CALL FACTORY FOR REPLACEMENT PARTS:
 888-994-7636

Parts List

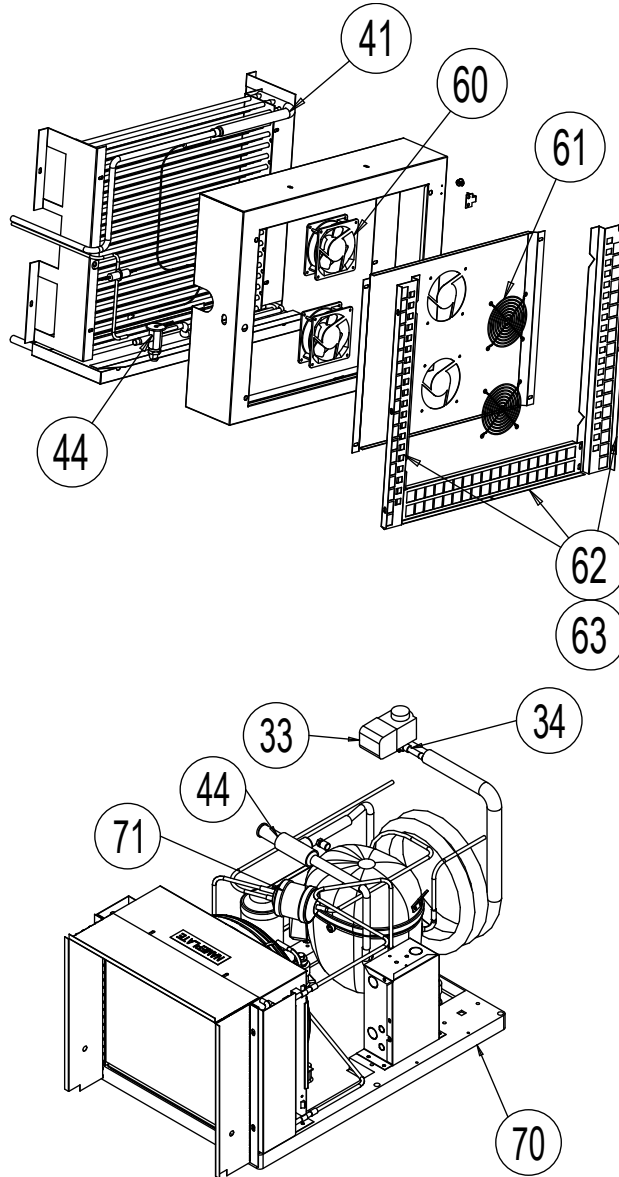

ITEM	PART NUMBER	DESCRIPTION	BC-918RI	BC-510WT	BC-003UC
60	RF FAN1401	FAN, AXIAL, 119 x 38mm		X	
61	RF FAN0703	FAN GUARD, NICKEL CHROME FINISH WIRE		X	
62	RP PIL1701	PILASTER, RACK BRACE, SET OF THREE, HINGED LEFT		X	
63	RP PIL1702	PILASTER, RACK BRACE, SET OF THREE, HINGED RIGHT		X	
70	RF CON1801	COND UNIT, 3/4HP LT R404 120V		X	
71	RF FLT377	FILTER, 1/4"		X	
NS	EL SWT0502	SWITCH, ROCKER 20A,277V,1HP,125V		X	

NS = NOT SHOWN

BC-003UC

MAIN ASSM/DOOR ASSM

CALL FACTORY FOR REPLACEMENT PARTS:
888-994-7636

Parts List

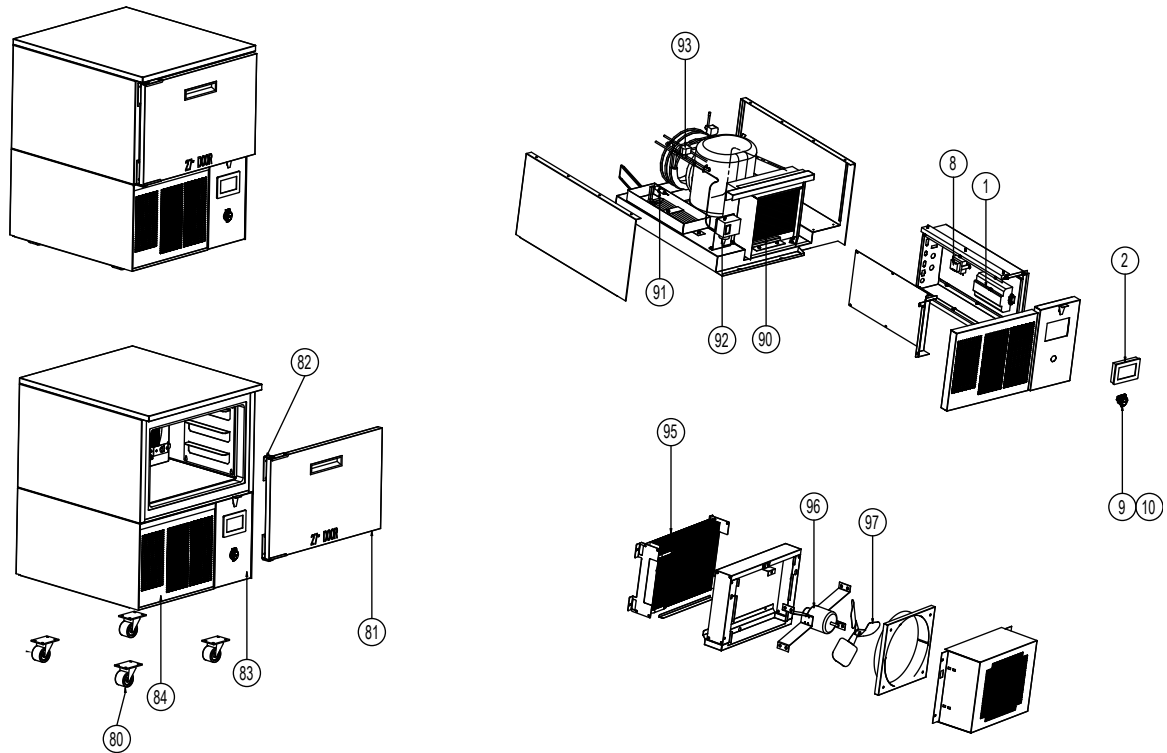

ITEM	PART NUMBER	DESCRIPTION	BC-918RI	BC-510WT	BC-003UC
80	HD CST2030	CASTER, 3-7/8" O/A SWVL NO BRAKE			X
81	RP DOR1707	DOOR, BC3, W/SWITCH, LH			X
	RP HNG9900	DOOR HINGE			X
NS	IN GSK1020	GASKET, 15.59 X 24.25 PUSH IN			X
83	RP PNL2106	CONTROL PANEL, BC-003UC			X
84	RP LVR2102	LOUVER, BC-003UC			X

NS = NOT SHOWN

**BC-003UC
MECHANICAL**

CALL FACTORY FOR REPLACEMENT PARTS:
888-994-7636

Parts List

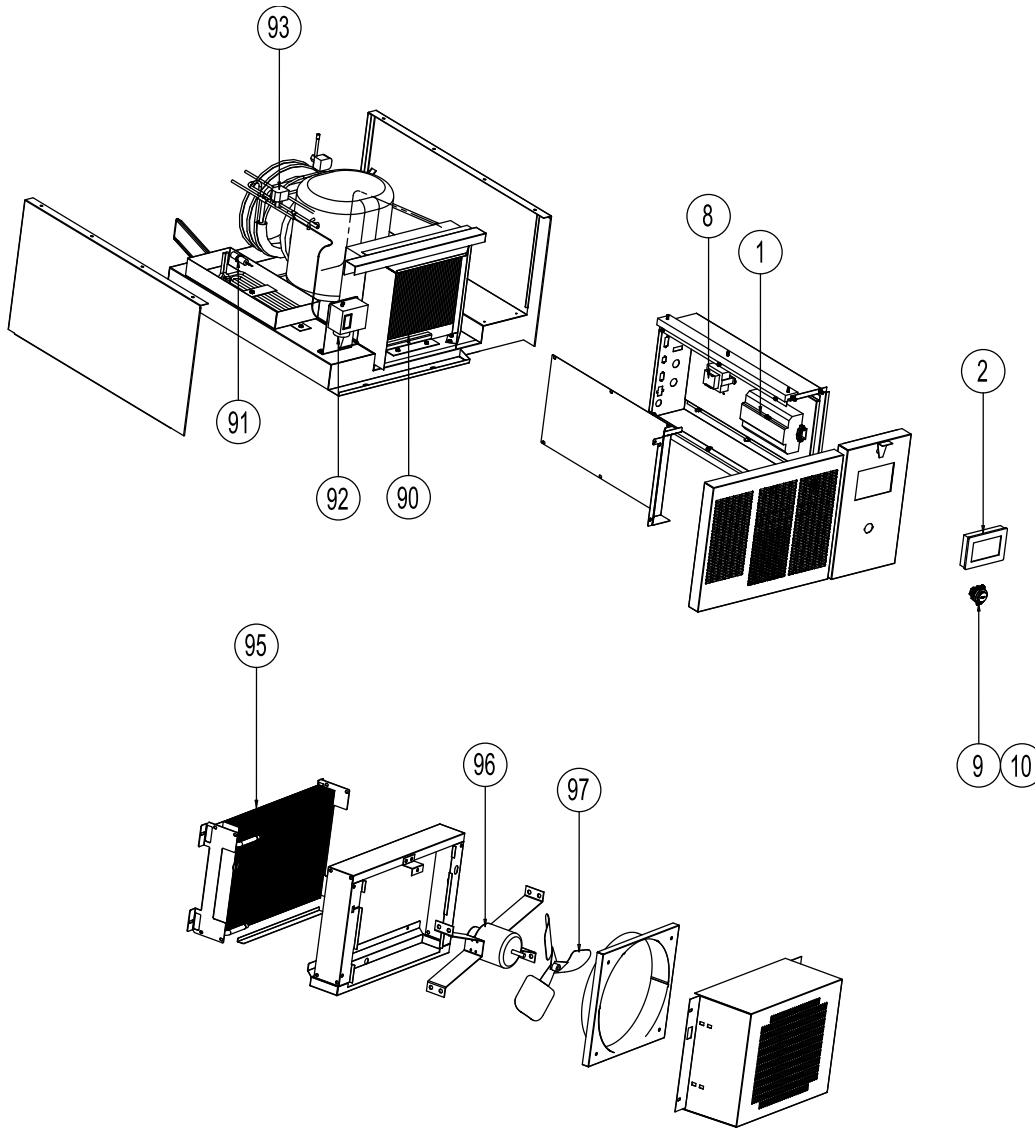

ITEM	PART NUMBER	DESCRIPTION	BC-918RI	BC-510WT	BC-003UC
90	RF CON2001	EMERSON COND UNIT, 1/2 MED R404A 120V/60/1			X
91	EL WIR274	CONDENSATE HEATER ELEMENT			X
92	RF CNT700	CONTROL, SINGLE LOW PRESSURE		X	X
93	RF SOL9801	SOLENOID, VALVE & 120V COIL		X	X
NS	RF FLT251	DRYER, 1/4"FILTER W/2ND 1/4			X
NS	EL WIR456	WIRE, 18" DRAIN EVAP FEMALE	X		X
NS	EL WIR461-12	20A POWER CORD, 9' 12GA		X	X
NS	EL WIR461-12	20A POWER CORD, 9' 12GA		X	X
95	RF COI9904	COIL, 12x17-1/4 BLAST CHILLER			X
96	EL MTR9902	MOTOR, FAN, 120V, 60HZ			X
97	RF BLD9905	BLADE, 12" EVAPORATOR FAN			X
NS	RF VLV9801	VALVE, 1 TON R404 HI-TEMP			X

NS = NOT SHOWN

BC-918RI

CALL FACTORY FOR REPLACEMENT PARTS:
888-994-7636

Wiring Diagram

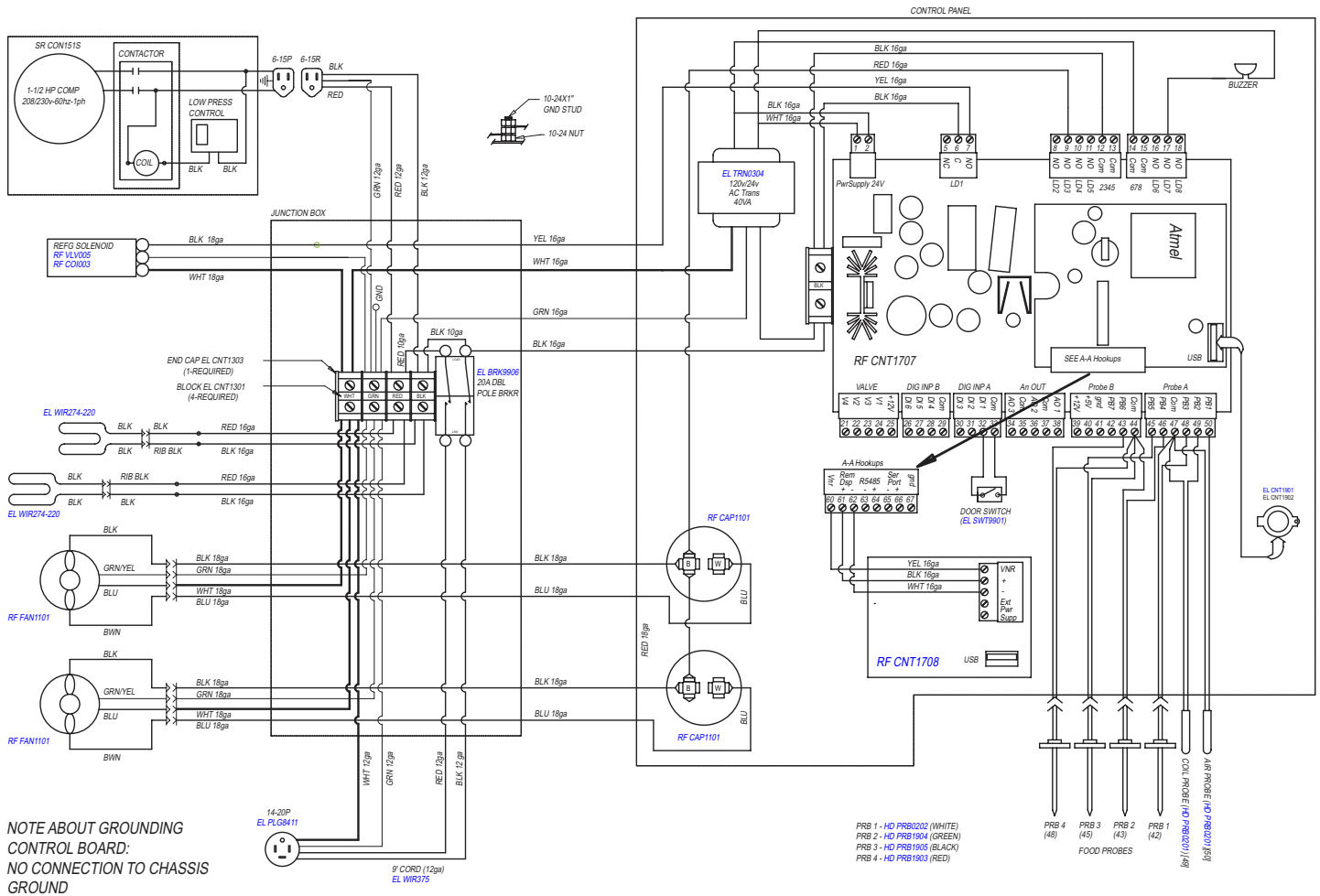

BC-510WT

CALL FACTORY FOR REPLACEMENT PARTS:
888-994-7636

Wiring Diagram

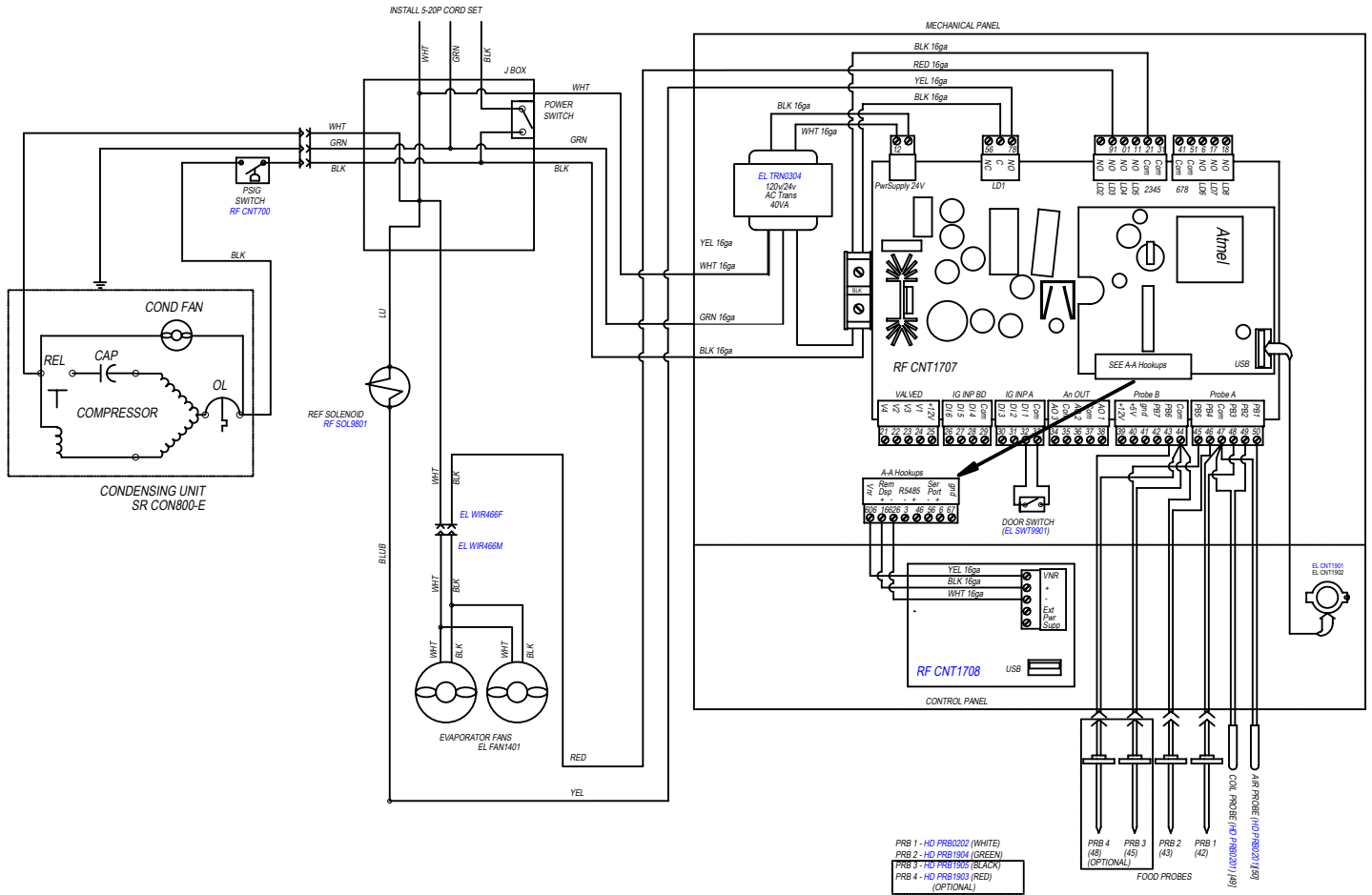

BC-003UC

CALL FACTORY FOR REPLACEMENT PARTS:
888-994-7636

Wiring Diagram

