

PRELIMINARY

# INSTALLATION AND OPERATION MANUAL

## Stainless Steel Indirect Fired Storage Water Heater

Model RSIT30 – RSIT115



This manual should be maintained in legible condition and kept adjacent to the boiler or in a safe place for future reference.



Effective: 09-24-21  
Replaces: 06-01-17  
P/N 241673 Rev. 2

UNCONTROLLED DOCUMENT IF PRINTED

## PRELIMINARY

**Revision 2 reflects the following changes:**

Reformatted to InDesign style guides from previous Quark format. Front cover safety information updated to reflect indirect nature of the heating system. Logos updated on cover and back page. Metric (SI) measurements added in tables and text throughout the document. Figure 2 revised on page 7. Figure 3 corrected on page 8. Figure 4 corrected on page 9.

---

**UNCONTROLLED DOCUMENT IF PRINTED**

PRELIMINARY  
**TABLE OF CONTENTS**

<b>1. WARNINGS .....</b>	<b>4</b>	<b>6. CONTROLS .....</b>	<b>11</b>
Pay Attention to These Terms .....	4	<b>7. START UP.....</b>	<b>12</b>
<b>2. GENERAL SAFETY.....</b>	<b>5</b>	Relief Valve .....	12
Scalding .....	5	Purging the System.....	12
Time/Temperature Relationships in Scalds.....	5	Flushing the System.....	12
<b>3. INTRODUCTION .....</b>	<b>6</b>	Checking Circulator.....	12
Product Receipt.....	6	Set the Thermostat to the Desired Temperature ...	12
<b>4. BEFORE INSTALLATION.....</b>	<b>6</b>	Verify the Boiler Functionality.....	12
Single-Wall Heat Exchanger .....	6	Verify the Water Temperature .....	13
Freeze Protection.....	6	<b>8. TROUBLESHOOTING .....</b>	<b>13</b>
Specification & Performance Data .....	7	<b>9. MAINTENANCE .....</b>	<b>13</b>
<b>5. INSTALLATION.....</b>	<b>8</b>	<b>10. REPLACEMENT PARTS .....</b>	<b>14</b>
Component Location .....	8	<b>11. WARRANTY .....</b>	<b>15</b>
Temperature & Pressure Relief Valve .....	8		
Plumbing .....	8		

# 1. WARNINGS

## Pay Attention to These Terms

<b>▲ DANGER</b>	Indicates the presence of immediate hazards which will cause severe personal injury, death or substantial property damage if ignored.
<b>▲ WARNING</b>	Indicates the presence of hazards or unsafe practices which could cause severe personal injury, death or substantial property damage if ignored.
<b>▲ CAUTION</b>	Indicates the presence of hazards or unsafe practices which could cause minor personal injury or product or property damage if ignored.
<b>CAUTION</b>	CAUTION used without the warning alert symbol indicates a potentially hazardous condition which could cause minor personal injury or product or property damage if ignored.
<b>NOTE</b>	Indicates special instructions on installation, operation, or maintenance which are important but not related to personal injury hazards.

**▲ WARNING:** Improper installation, adjustment, alteration, service or maintenance can cause serious injury or property damage. Refer to this manual. For assistance or additional information, consult a qualified installer or service agency.

**CAUTION:** The recommended water temperature for normal residential use is 120°F (49°C). The control temperature setting does not always reflect the outlet water temperature, which could occasionally exceed 120°F (49°C). The variation in outlet temperature could be based on factors including but not limited to usage patterns and type of installation. Test your water at the tap nearest to the indirect water heater.

**▲ WARNING:** Hotter water increases the risk of scald injury. Before adjusting the water temperature setting, read this instruction manual. Temperatures at which injury occurs vary with the person's age and the length of exposure.

- The slower reaction time of children, elderly, and physically or mentally-challenged persons increases the scalding hazard to them. It is recommended that lower water temperatures be used where these exposure hazards exist. Such households may require a temperature setting less than 120°F (49°C) to prevent accidental contact with hot water.
- To lower water temperature, use point-of-use temperature limiting devices.

## 2. GENERAL SAFETY

### Scalding

**⚠ DANGER:** Safety and energy conservation are factors to be considered when selecting the water temperature setting of a water heater's temperature control. Water temperatures above 125°F (52°C) can cause severe burns or death from scalding. Be sure to read and follow the warnings outlined on the label pictured below. This label is also located on the water heater.

**⚠ CAUTION:** The recommended water temperature setting for normal residential use is 120°F (49°C).

⚠ DANGER

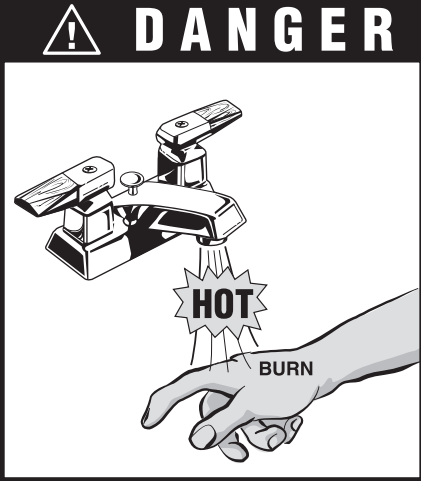

**Water temperature over 125°F can cause instant severe burns or death from scalds.**

**Children, disabled, and elderly are at highest risk of being scalded.**

**See instruction manual before setting temperature at water heater.**

**Feel water before bathing or showering.**

**Temperature limiting valves are available, see manual.**

Water Temp	Time to Product Serious Burn
120°F (49°C)	More than 5 minutes
125°F (52°C)	1-1/2 to 2 minutes
130°F ( 54°C)	About 30 seconds
135°F (57°C)	About 10 seconds
140°F (60°C)	Less than 5 seconds
145°F (63°C)	Less than 3 seconds
150°F (66°C)	About 1-1/2 seconds
155°F (68°C)	About 1 second

Table courtesy of the Shriners Burn Institute.

**Table A. Time to Produce Serious Burns**

### Time/Temperature Relationships in Scalds

**⚠ DANGER:** Households with small children, disabled, or elderly persons may require a 120°F (49°C) or lower control (thermostat) setting to prevent contact with HOT water.

**⚠ DANGER:** Hotter water increases the potential for Hot Water SCALDS.

**NOTICE:** Mixing valves are available for reducing point-of-use water temperature by mixing hot and cold water in branch water lines. Contact a licensed plumber or the local plumbing authority for further information.

For a guide in determining the proper water temperature for your home see.

Maximum water temperatures occur just after the boiler has shut off. To find the water temperature being delivered, turn on a hot water faucet, place a thermometer in the water stream and read the temperature.

## PRELIMINARY

representative or visit our website at [www.raypak.com](http://www.raypak.com). Keep this manual with the water heater after installation.

Local plumbing and electrical codes must be followed in the installation of this indirect water heater. In the absence of a local code, use the UNIFORM PLUMBING CODE and the NFPA Code. Local codes may supersede instructions in this installation manual.

Thank you for purchasing a Raypak® product. We hope you will be satisfied with the high quality and durability of our equipment.

## Single-Wall Heat Exchanger

This Indirect fired water heater uses a single-wall heat exchanger. In order for this water heater to meet the requirements of the Uniform Plumbing Code, the following requirements must be met.

1. The boiler water pressure must be limited to 30 PSI (207 kPa). An approved 30 PSI (207 kPa) relief valve must be installed in the boiler loop.
2. The boiler heat transfer medium must be either potable water or use fluid additives that have a toxicity rating of Class 1.
3. Bear a label on the system with the Wording "Caution" followed by:
  - a. The heat transfer medium must be water or other nontoxic fluid having a toxic rating of Class 1 as listed in clinical Toxicology of Commercial Products, 5th edition.
  - b. The pressure of the heat-transfer medium must be limited to a maximum of 30 PSIG (207 kPa) by an approved safety or relief valve.

## Freeze Protection

The water heater and water lines must be protected from exposure to freezing temperatures. Freezing temperatures can cause damage to this indirect water heater. The unit must be located indoors.

If the water heater is to remain idle for an extended period of time, the power and water to the boiler system should be turned off to conserve energy and prevent a build-up of dangerous hydrogen gas.

The water heater and piping should be drained if they might be subjected to freezing temperatures.

After a long shut-down period, the water heater's operation and controls should be checked by qualified service personnel. Make certain the water heater is completely filled again before placing it in operation.

## 3. INTRODUCTION

The Raypak indirect water heater uses heat from a boiler to heat domestic water. The heat is transferred to the water by a coil heat exchanger inside of the tank. The indirect storage tank stores the energy from the boiler for use later. With the excellent thermal insulation in the Raypak water heater, the boiler turns on and off less often. To maintain energy efficiency the stainless steel tank is fully insulated with 2 inches (51 mm) of rigid foam. The Raypak indirect water heater is an efficient means of heating water.

This indirect water heater has all stainless steel construction. The stainless steel tank is fully welded, pickled and passivated. The stainless steel resists corrosion assuring a long service life.

The highest outlet temp that is supported is 150°F (66°C). See "Specification & Performance Data" on page 7.

### Product Receipt

On receipt of your unit it is suggested that you visually check for external damage to the shipping carton. If the carton is damaged, make a note to that effect on the Bill of Lading when signing for the shipment. Next, remove the water heater from the carton. Report any damage to the carrier immediately.

On occasion, items are shipped loose. Be sure that you receive the correct number of packages as indicated on the Bill of Lading.

Claims for shortages and damages must be filed with the carrier by consignee. Permission to return goods must be received from the factory prior to shipping. Goods returned to the factory without an authorized Returned Goods Receipt number will not be accepted. All returned goods are subject to a restocking charge.

When ordering parts, you must specify the model and serial number of the water heater. When ordering under warranty conditions, you must also specify the date of installation.

Purchased parts are subject to replacement only under the manufacturer's warranty. Debits for defective replacement parts will not be accepted. Parts will be replaced in kind only per Raypak's standard warranties.

## 4. BEFORE INSTALLATION

Raypak strongly recommends that this manual be reviewed thoroughly before installing your indirect-fired Storage Water Heater. Please review the General Safety information before installing the unit. Factory warranty does not apply to units that have been improperly installed or operated. (Refer to the warranty at the back of this manual.) Installation and service must be performed by a qualified installer, or service agency. If, after reviewing this manual, you still have questions which this manual does not answer, please contact your local Raypak

**PRELIMINARY**  
**Specification & Performance Data**

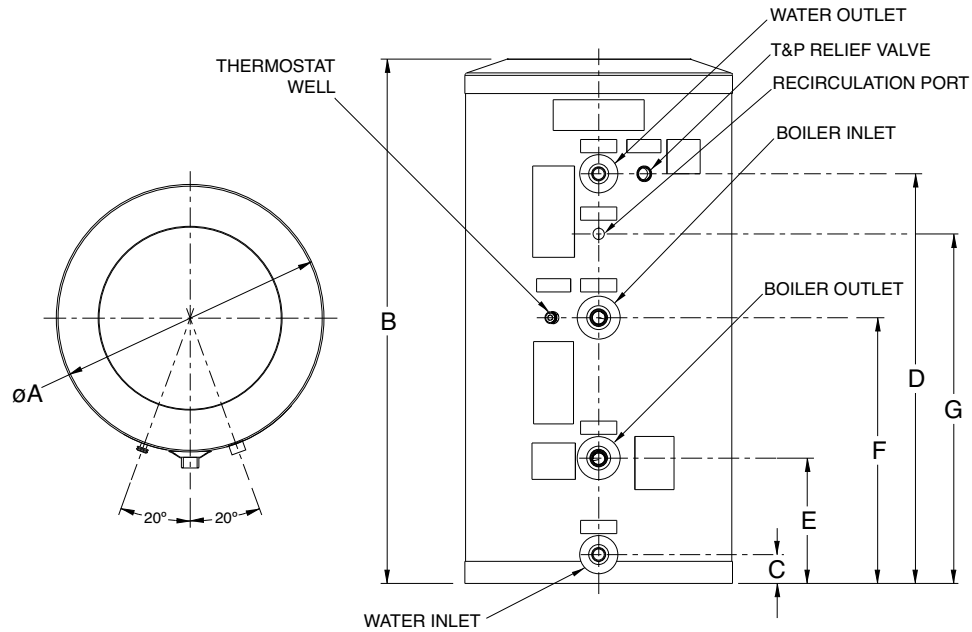

**Figure 1. Indirect Water Temperature Dimensions**

Model	Tank Weight Empty Lb. (kg)	Tank Weight Full Lb. (kg)	Water Inlet/Outlet	Heat Exchanger Coil Conn.	Tank Dia in. (mm)	Tank Height in. (mm)	Water Inlet Height in. (mm)	Water Outlet/T&P Height in. (mm)	Boiler Outlet Height in. (mm)	Boiler Inlet/Thermostat Height in. (mm)	Recirc. Port Height in. (mm)
					A	B	C	D	E	F	G
RSIT30	48 (21.8)	262 (119)	3/4" NPT	1" NPT	20.1 (510)	39.6 (1006)	2.2 (56)	30.9 (785)	9.4 (239)	22.0 (559)	
RSIT40	60 (27.3)	382 (173)	3/4" NPT	1" NPT	21.8 (554)	46.9 (1141)	2.0 (51)	37 (940)	10.2 (259)	23.6 (599)	
RSIT50	76 (34.5)	535 (243)	3/4" NPT	1" NPT	21.8 (554)	62.7 (1593)	2.0 (51)	52.8 (1341)	10.2 (259)	26.3 (668)	
RSIT65	85 (38.6)	610 (277)	3/4" NPT	1" NPT	21.8 (554)	70.2 (1783)	2.0 (51)	60.3 (1532)	10.2 (259)	26.3 (668)	
RSIT80	106 (48.2)	744 (337)	1" NPT	1" NPT	23.8 (605)	69.9 (1775)	1.9 (48)	60.5 (1537)	9.9 (251)	33.3 (846)	42 (1066)
RSIT115	150 (68.2)	1079 (489)	1-1/2" NPT	1" NPT	28.9 (734)	65.8 (1671)	2.4 (61)	53 (1346)	11.5 (292)	31.9 (810)	41 (1041)

**Table B. Indirect Water Temperature Dimensions**

Model	Potable Water Volume Gal (L)	Heat Source Water Volume Gal (L)	First Hour Rating Gal/hr (L/hr)	Continuous Draw Rating Gal/hr (L/hr)	Standby Loss °F/hr (°C/hr)	Minimum Boiler Output MBTUH (kw/h)	Coil Length Ft (m)	Heating Surface Area ft² (m²)	Heating Coil Flow GPM (L/m)	Coil Pressure Drop at Flow Ft. wc. (m wc)
RSIT30	25.7 (97)	0.8 (3.0)	172 (651)	149 (564)	1.4 (0.8)	96 (328)	27 (8.2)	6.9 (0.64)	14.0 (53)	8.4 (2.6)
RSIT40	38.6 (146)	1.0 (3.8)	207 (783)	172 (651)	0.9 (0.5)	108 (369)	31 (9.4)	8.0 (0.74)	14.0 (53)	9.4 (2.9)
RSIT50	55.0 (208)	1.3 (4.9)	261 (988)	208 (787)	0.7 (0.4)	133 (454)	39 (11.9)	10.0 (0.93)	14.0 (53)	5.0 (1.5)
RSIT65	62.9 (238)	1.3 (4.9)	270 (1022)	209 (791)	0.6 (0.3)	135 (461)	39 (11.9)	10.0 (0.93)	14.0 (53)	4.8 (1.4)
RSIT80	76.5 (290)	1.6 (6.0)	348 (1317)	276 (1045)	0.6 (0.3)	177 (604)	47 (14.3)	14.6 (1.4)	14.0 (53)	4.5 (1.4)
RSIT115	111.3 (421)	2.5 (9.5)	412 (1559)	309 (1170)	0.5 (0.3)	199 (679)	55 (16.8)	17.1 (1.6)	14.0 (53)	7.0 (2.1)

Note: Rating Data based on 180°F (82°C) boiler output water, potable water inlet 58°F (14°C) and outlet 135°F (57°C). Other operating conditions are possible.

**Table C. Performance Data**

## 5. INSTALLATION

### Component Location

For best results, the indirect water heater should be in a central location close to the boiler. This will minimize heat loss in the boiler piping and reduce wait times for hot water at the point of use. The indirect water heater must be protected from freezing temperatures.

### Anode Rods

The use of anode rods is not required for this unit. The all-stainless steel construction of this tanks minimizes corrosion.

### Boiler and Circulator Sizing

The ratings published in this manual for your Raypak indirect water heater can be obtained through proper selection of boiler output and circulator capacity. See the performance data in **Table C**.

To determine the appropriate circulator for your system, follow these three steps:

1. Calculate the pressure drop of all straight pipe and fittings on the supply and return at the desired flow rate.
2. Add the pressure drop from Step 1 to the pressure drop through the indirect water heater coil to obtain a total pressure drop. For friction loss see **Table C**.
3. Select a circulator pump that will provide adequate flow at the total pressure drop. A pump performance curve should accompany every circulator pump.

### Temperature & Pressure Relief Valve

This water heater requires a temperature and pressure relief valve. The T&P relief valve is supplied by the installer. This relief valve is required for safe operation of the unit to protect from excessive temperatures and pressures. A discharge pipe should be installed to the relief valve. This discharge piping should terminate in a safe location. This discharge piping must comply with local and national plumbing codes. The piping must be rated for 120°F (49°C) and 150 PSI (1034 kPa).

### Plumbing

**⚠ WARNING:** Where this Indirect Water Heater is installed at an elevation above the fixture outlets in the hot water system, a vacuum relief valve shall be field-installed on the storage tank.

**⚠ CAUTION:** Damage due to over-tightening of fitting is not covered by warranty.

### PRELIMINARY

A tempering valve may be required by local jurisdiction to protect the user from scalding. Raypak recommends the use of a tempering valve with this indirect water heater. The tempering valve limits the water temperature at the point of use.

If local municipal codes require a backflow preventer, an expansion tank shall be required. The expansion tank will prevent pressure build-up inside of the indirect water heater and associated piping. The expansion tank must be installed in the domestic water piping close to the tank. No shutoff valve is allowed between the expansion tank and the indirect water heater.

All water connections made to this heater should be sealed with thread tape or pipe dope. It is recommended to use a shutoff valves on this tank for servicing. The shutoff valves should not isolate the relief valve or expansion tank from the indirect water heater. The inlet of the heater should be piped with a drain connection for servicing the heater.

Several piping diagrams are shown depicting various installation variations. Use these diagrams (**Figure 3** and **Figure 4**) to help piping the indirect water heater.

This unit is not supplied with a separate drain fitting. It is recommended that one be added to the inlet piping. For drain valve installation see the depiction **Figure 2**.

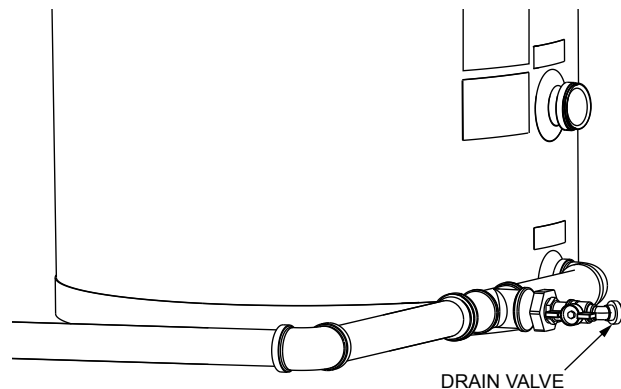

**Figure 2. Drain Valve Installation**

For a depiction showing the connection of the indirect water heater to the system loop, see **Figure 3**. This diagram also shows the optional anti-scalding mixing valve (may be required in some jurisdictions). The boiler shown in this diagram is the Raypak XPak FT model. Other boilers may be used instead.

For a depiction showing the connection of the indirect water heater directly to the boiler loop, see **Figure 4**. Other boilers may be used instead.

PRELIMINARY

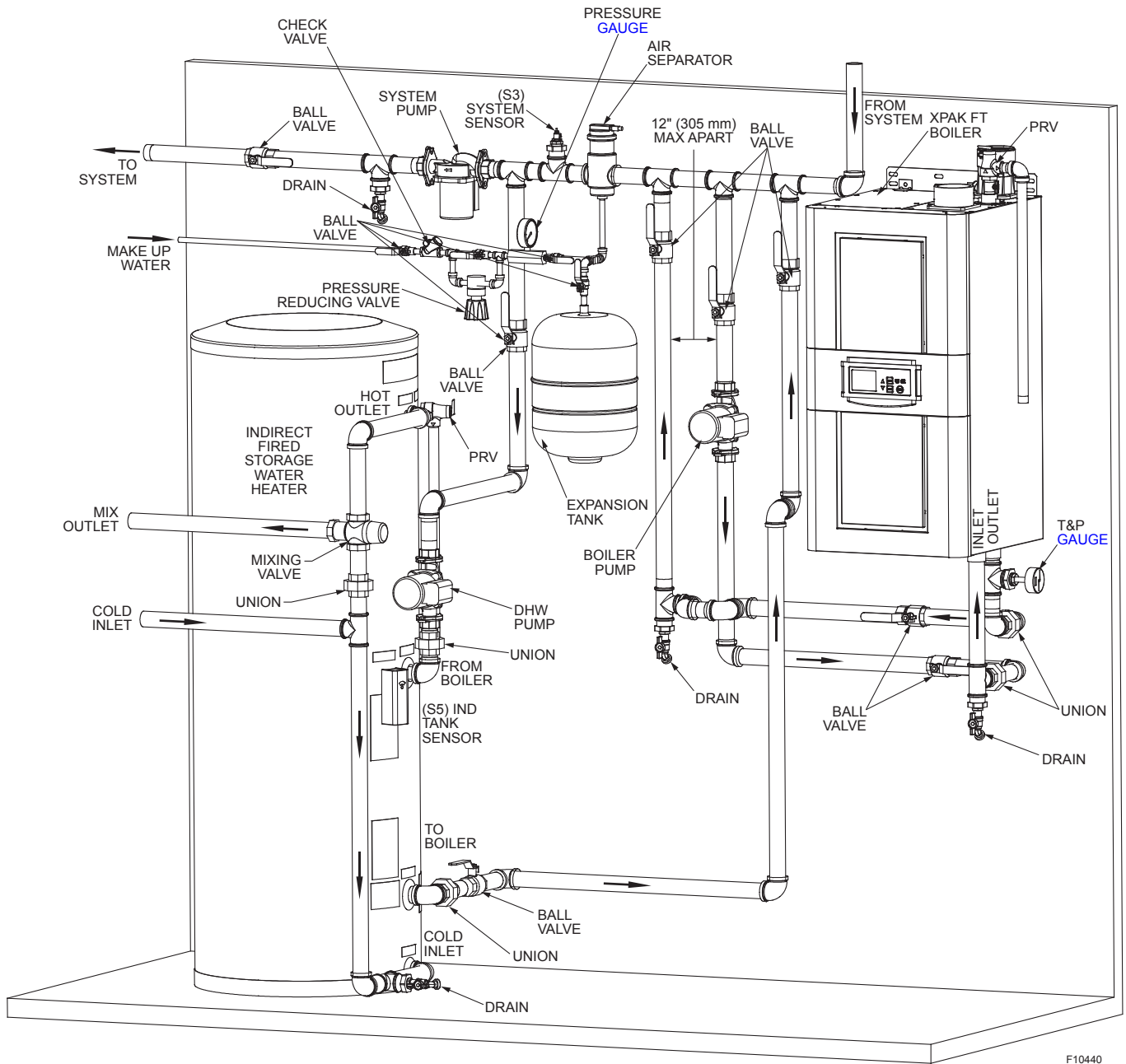
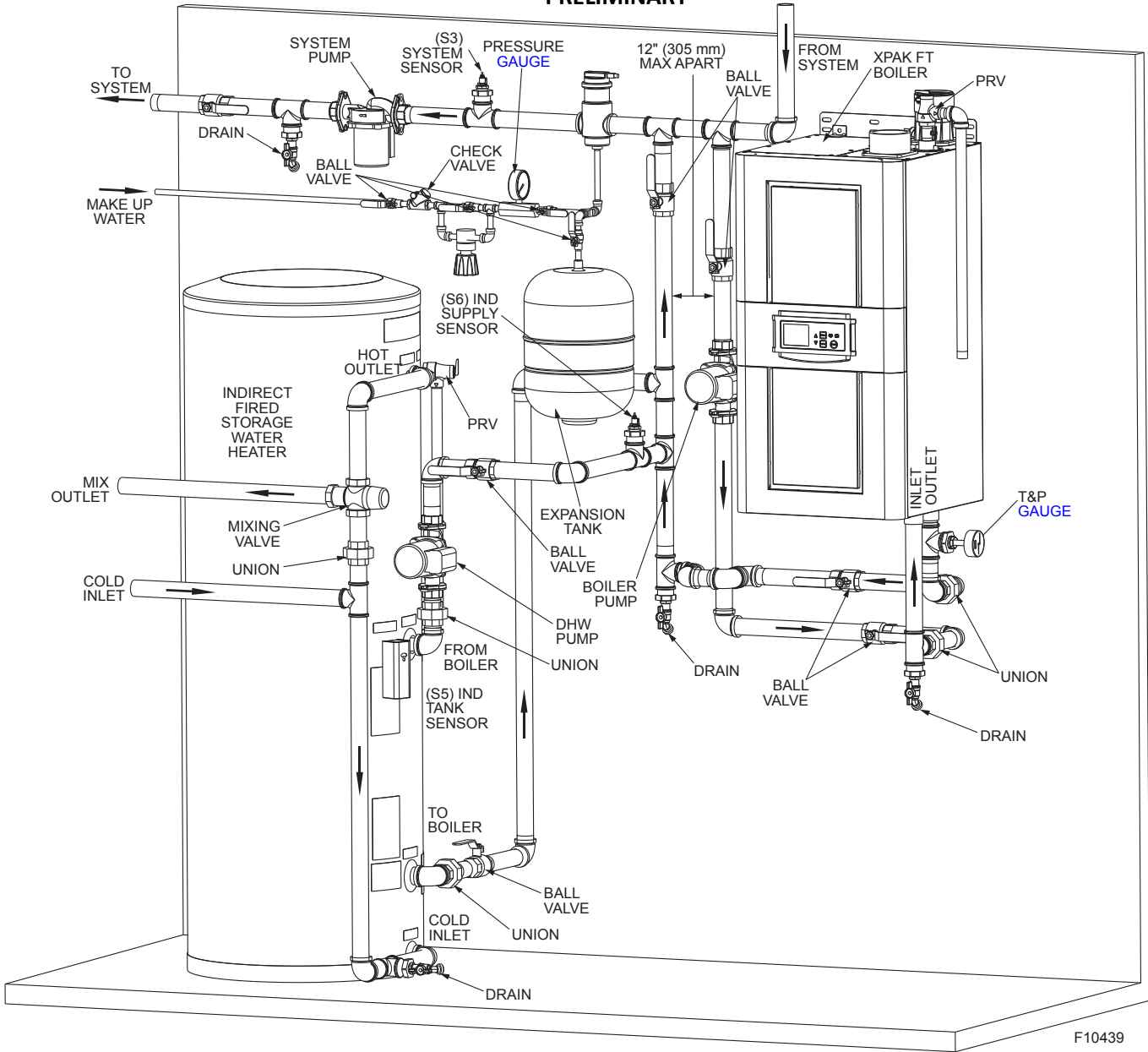

Figure 3. VERSA Mode 2

F10440

PRELIMINARY



F10439

Figure 4. VERSA Mode 3

**PRELIMINARY**

## 6. CONTROLS

A Control system is required for this indirect water heater to function correctly. Some possible control schemes are explained below. The particular control scheme will depend upon the specific installation.

This indirect water heater can be connected to any Raypak boiler that is equipped with a VERSA control. The VERSA control is pre-configured to handle an indirect storage water heater. The VERSA control can also be configured to give priority to the domestic hot water or to space heating. To connect the unit to a VERSA-equipped boiler, read the VERSA IC Installation & Operating Manual P/N 241493.

For the VERSA system to function properly, a 10K Ohm thermistor needs to be installed into the tank aquastat location. See **Figure 5**.

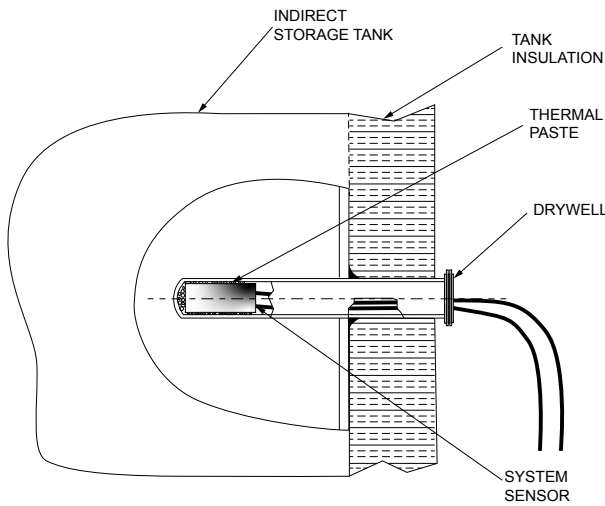

**Figure 5. 10 kOhm Thermistor Installation**

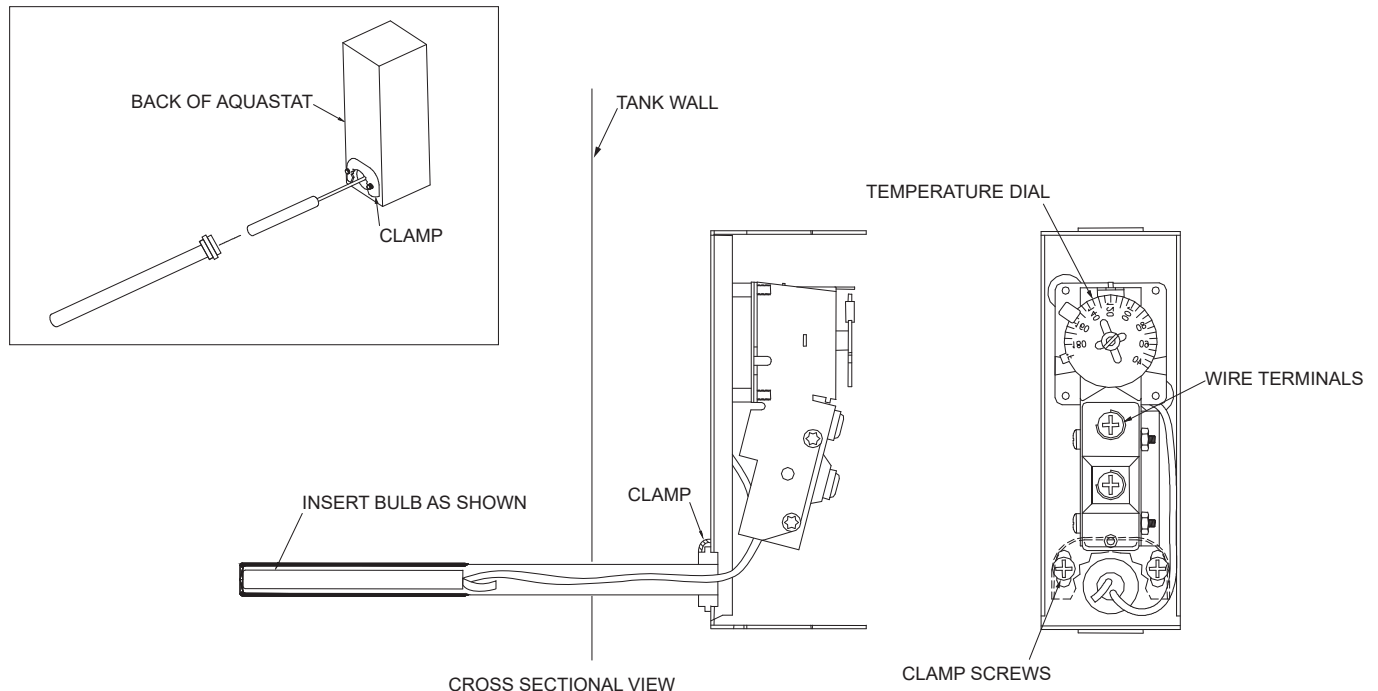

**Figure 6. Aquastat Well**

The indirect water heater can be controlled by an aquastat. The aquastat measures the domestic water temperature inside the tank. When more heat is required, the aquastat will turn on the pump to circulate boiler water through the indirect water heater.

To install the aquastat into the heater, see **Figure 8**.

For a controls diagram for a boiler that is always on, maintaining hot water in the boiler loop see **Figure 6**. The aquastat turns on a circulator to induce boiler water flow through the indirect water heater.

For a depiction of wiring the indirect water heater to a cold-start boiler system using a Honeywell RS845 see **Figure 7**. In this type of system, the boiler does not run unless there is a call-for-heat in one of the zones of the system. When connecting to a cold-start boiler, always remember that in principle an indirect water heater operates as another heating zone. The difference is that when the indirect water heater calls for heat, the indirect water heater circulator must start rather than opening a zone valve; the system circulator stays off, and the boiler must light to reach Operating Temperature.

**WIRING NOTES:**

- 1. Dashed lines indicate low voltage (24 VAC).
- 2. Use jumper wire between terminals #1 and #3 on R845 relay.

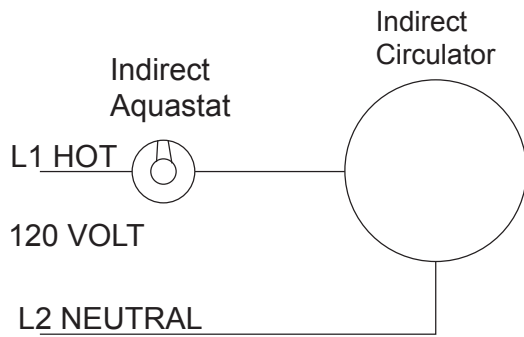

Figure 7. Boiler Maintaining 180°F (82°C)

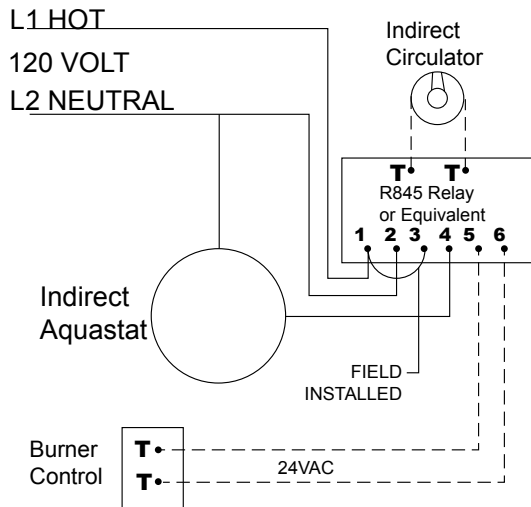

Figure 8. Boiler

## 7. START UP

### Relief Valve

A new combination temperature and pressure (T&P) relief valve, complying with the Standard for Relief Valves and Automatic Gas Shut-Off Devices for Hot Water Supply Systems, ANSI Z21.22, is supplied by the installer. It must be installed in the opening provided and marked for the purpose on the water heater. No valve of any type should be installed between the relief valve and the tank. Local codes shall govern the installation of relief valves.

The pressure rating of the relief valve must not exceed 150 PSI (1034 kPa), or the maximum working pressure of the water heater as marked on the rating plate.

The BTUH rating of the relief valve must equal or exceed the BTUH input of the water heater as marked on its rating plate.

Position the outlet of the relief valve above a suitable open drain to eliminate potential water damage. Piping used must be of a type approved for hot water distribution.

The discharge line must be no smaller than the outlet of the valve and must pitch downward from the valve to allow complete gravity drainage of the relief valve and discharge line.

### PRELIMINARY

The end of the discharge line should not be threaded or concealed, and must be protected from freezing. No valve of any type, restriction, or reducer coupling may be installed in the discharge line.

### Purging the System

Purge the system of air and check for leaks at all of the connections.

### Flushing the System

Flush the system completely. It is important to clear any debris and residues from inside the piping and tank before the water heater will be put to use by the customer. To flush the system, open one of the hot water valves at the point of use after the water heater. Allow enough water to flow through the tank to change the water volume at least two times.

### Checking Circulator

Check that the circulator or zone valve operates when there is a call-for-heat. When a call-for-heat is initiated, water should begin to flow through the indirect water heater's coil.

### Set the Thermostat to the Desired Temperature

For normal water heating installations, Raypak recommends an operating temperature of 120°F (49°C). Other temperatures may be required by the particular installation. To minimize burns and scalding, Raypak recommends that the water temperature be verified at the point of use. See "Verify the Water Temperature".

For VERSA-equipped Raypak boilers, the indirect water heater's setpoint is controlled by the boiler and the 10 kOhm thermistor installed in the water heater's thermal well. To adjust the water heater setpoint, please refer to the equipped boiler, read the VERSA IC Installation & Operating Manual P/N 241493.

For installations with an aquastat control, the temperature is adjusted at the aquastat control located on the tank thermowell. To adjust the setpoint temp, rotate the dial on the aquastat to the desired setpoint.

### Verify the Boiler Functionality

When a call-for-heat is initiated, the boiler should come on and begin heating. The boiler should also shut off when the tank has reached its setpoint. If the boiler does not heat, please check that water circulator is functioning and that the wiring is correct.

**PRELIMINARY**

## Verify the Water Temperature

Raypak recommends that the water temp be verified at the point of use. First, let the indirect water heater come to temperature. The water heater has reached its setpoint

when the boiler heating water has stopped flowing through the heat exchanger. To verify the water temp, open the shutoff valve at the point of use. Let the water run for several minutes until the temperature has stabilized. Measure this stabilized water temperature.

## 8. TROUBLESHOOTING

Problem	Cause	Solution
No potable hot water	Boiler not operating.	Refer to boiler installation manual.
		Check boiler circuit breaker.
		Check boiler thermostat setting.
	Zone valve not opening.	Replace zone valve.
	Circulator pump not working.	Check power supply.
		Replace circulator.
	Tank thermostat.	Thermostat set too low.
Check thermostat wiring.		
Scale build-up.	Check coil for scale build up. Descale if necessary.	
Water too hot	Thermostat set too high.	Adjust thermostat.
	Tempering valve malfunction.	Refer to tempering valve instructions.
Insufficient hot water	Thermostat set too low.	Adjust thermostat.
	Undersized boiler, no priority to domestic hot water.	Replace boiler or rewire for priority.
	Demand higher than indirect water heater capacity.	Determine peak usage, and check tank sizing chart.
		Install mixing valve, and raise tank temperature.
Insufficient circulator flow.	Check for restrictions in piping.	
	Check circulator sizing.	
T&P valve discharges	Tank temperature too high.	Lower tank aquastat setting.
		Faulty aquastat.
	Pressure too high.	Check incoming water pressure.
		Closed loop systems require an expansion tank.

**Table D. Troubleshooting**

## 9. MAINTENANCE

- The Raypak indirect storage water heater requires little maintenance. Below is a list of maintenance tasks that should be performed annually.
- Visually check for leaks in the system. This includes the domestic water piping, boiler piping, relief valve, and the handhole cover at the top of the tank.
- Have the boiler inspected according to its manufacturer’s operation manual.
- Lift the lever on the relief valve to verify that the valve functions.
- Periodically open the indirect water heater relief valve to verify its functionality.

**PRELIMINARY  
MANUFACTURER:**

# 10. REPLACEMENT PARTS

**NOTE:** To supply you with the correct part, it is important that you supply the heater model number, serial number and type of gas when applicable.

**2151 Eastman Avenue  
Oxnard, Ca 93030**

Below is a list of the replacement parts for the Stainless Steel Indirect Water Heater from the IPL diagram.

Any part returned for replacement under standard company warranties must be properly tagged with a return parts tag, completely filled in with the heater serial number, model number, etc., and shipped to the Company freight prepaid. If determined defective by the Company and within warranty, a like part or equal substitution will be returned, freight collect. Credit will not be issued.

Call Out	Description	RSIT30	RSIT40	RSIT50	RSIT65	RSIT80	RSIT115
1-M	Hand Hole Cover Assembly	016516F	016516F	016516F	016516F	016516F	016516F
2-M	O-Ring Seal	016517F	016517F	016517F	016517F	016517F	016517F
3-M	Temperature & Press Relief Valve	016515F	016515F	016515F	016515F	016515F	016515F

**Table E. Replacement Part Kit Numbers**

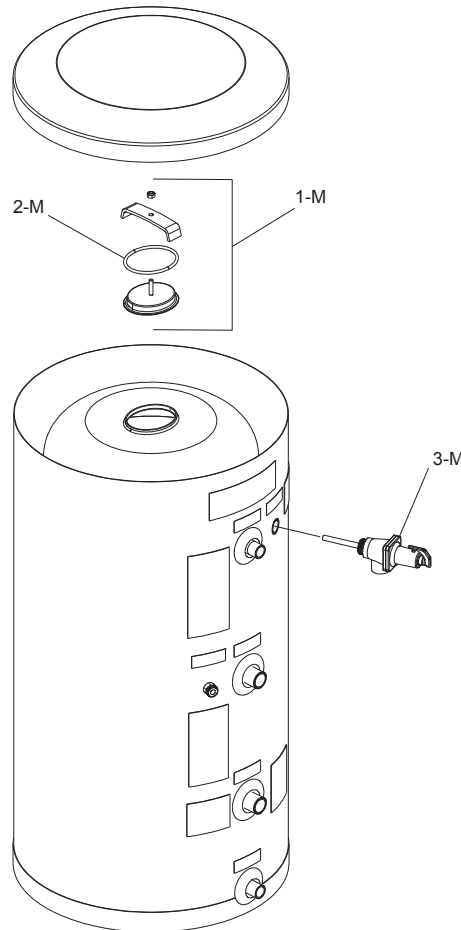

**Figure 9. Replacement Parts**

# 11. WARRANTY

## PRELIMINARY LIMITED WARRANTY

### For Raypak® Stainless Steel Indirect Water Heaters and Storage Tanks

#### GENERAL

Raypak Inc. (Raypak) warrants this indirect water heater to be free from defects in materials and workmanship, under normal use and service, for the appropriate applicable Warranty periods. At its option, Raypak will repair or replace a malfunctioning indirect water heater in accordance with the terms of this Limited Warranty, if it fails in normal use and service during the appropriate applicable Warranty periods. The replacement indirect water heater must be supplied by Raypak. The replacement indirect water heater unit, will be warranted only for the unexpired portion of the original unit's appropriate applicable Warranty period.

#### EFFECTIVE DATE

The effective Date of warranty coverage (or the beginning of the applicable Warranty periods) is the date of installation of the water heater if properly documented. Otherwise, it is the date of manufacture of the water heater plus ninety (90) days.

#### APPLICABLE WARRANTY PERIODS

The applicable Warranty periods will vary depending on the ownership and/or use (or water heating application) of the unit as follows:

**LIFETIME RESIDENTIAL LIMITED WARRANTY COVERAGE** – as long as the indirect water heater is installed in a single family dwelling owned by its original owner/end user, Raypak will furnish a replacement unit (if the tank leaks) provided the unit has not been moved from the original installation site or been rendered inoperable by an event listed in the Warranty exclusions section of this Limited Warranty. This warranty coverage applies only to the original indirect water heater purchased and installed at each site. It does not apply to any in-warranty replacement indirect water heater. The owner/end user must be able to provide proof that he or she purchased the indirect unit in order to qualify for Lifetime Residential Limited Warranty coverage.

**10 YEAR RESIDENTIAL LIMITED WARRANTY COVERAGE** – if the indirect water heater is installed in a single family dwelling owned by persons other than the original owner/end user, the applicable Warranty periods are ten (10) years from the effective Date for the tank provided the unit has not been moved from the original installation site or rendered inoperable by an event listed in the Warranty exclusions section of this Limited Warranty. This warranty coverage applies only to the original indirect water heater purchased and installed at each site. It does not apply to any in-warranty replacement indirect water heater.

**5 YEAR COMMERCIAL LIMITED WARRANTY COVERAGE** – if the indirect water heater is installed in a multiple family dwelling or any other type of commercial business, the applicable Warranty periods are five (5) years from the effective Date for the tank provided the unit has not been moved from the original installation site or rendered inoperable by an event listed in the Warranty exclusions section of this Limited Warranty. This warranty coverage applies only to the original indirect water heater purchased and installed at each site. It does not apply to any in-warranty replacement indirect water heater.

#### WARRANTY EXCLUSIONS

This Limited Warranty will not cover:

- a) Service trips to the installation site to teach you how to install, use, or maintain this indirect water heater or to bring the indirect water heater's installation into compliance with local building codes and regulations.
- b) Damages, malfunctions, or failures resulting from failure to install the indirect water heater in accordance with applicable building codes/ordinances or good plumbing and electrical trade practices.
- c) Damages, malfunctions, or failures resulting from improper installation or failure to operate and/or maintain the indirect water heater in accordance with the manufacturer's instructions provided.
- d) Performance problems caused by improper sizing of the boiler and/or the indirect water heater.
- e) Chloride content >250ppm, maximum water temperature in excess of 90°C/194°F.
- f) Problems associated with the chemistry of the water being heated (for example: rotten egg smell or inappropriate use of water softening equipment);
- g) Damages, malfunctions, or failures caused by using the indirect water heater to perform functions it was not designed to perform, abuse, accident, fire, flood, freeze, lightning, acts of God, and the like.
- h) Tank failures (leaks) caused by operating the indirect water heater in a corrosive or contaminated atmosphere.
- i) Damages, malfunctions, or failures caused by operating the indirect water heater with an empty, or partially empty, tank.
- j) Damages, malfunctions, or failures caused by operating the indirect water heater at water temperatures exceeding the maximum setting of the operating, or high limit, control.
- k) Tank failures caused by operating the indirect water heater when it is not supplied with potable water, free to circulate at all times.
- l) Damages, malfunctions, or failures caused by subjecting the tank to pressures greater than those shown on the rating label.
- m) Damages, malfunctions, or failures resulting from the use of any attachment, including any energy saving device, not authorized by Raypak.
- n) Indirect units installed outside the fifty states (and the District of Columbia) of the United States of America and its territories and the Dominion of Canada.
- o) Indirect units moved from the original installation location.
- p) Indirect water heaters that have had their rating labels altered or removed. An indirect water heater should not be operated if the rating label is removed.

#### LABOR, MATERIALS, SHIPPING, AND PROCESSING COSTS

This Limited Warranty does not cover any labor expenses for service, repairs, reinstallation, permits, or removal and disposal of a leaking indirect water heater or a defective component part of an indirect water heater. All such expenses are the owner's responsibility. This Limited Warranty does not cover any reinstallation material costs for pipe, valves, fittings, or any other materials and/or services required to repair or replace a malfunctioning indirect water heater or defective component part of an indirect water heater. All such expenses are the owner's responsibility. Raypak will pay the transportation costs for an "in-warranty" replacement indirect water heater, to a convenient delivery point (selected by Raypak) near the place the original indirect water heater was purchased; such as a local Raypak water heater Distributor. The owner of the indirect water heater will be responsible for any local freight charges, including the cost of returning an indirect water heater, replaced "in-warranty" to a convenient location (selected by Raypak); such as a local Raypak water heater Distributor. Raypak does not authorize, recommend, or receive any benefit from any warranty claims processing or similar fees charged by others to process warranty claims for any Raypak indirect water heater. Raypak will not reimburse any party for these, or any other, fees not specifically covered in this Limited Warranty document.

**PRELIMINARY**

**HOW TO OBTAIN WARRANTY CLAIM ASSISTANCE**

Any claim for warranty assistance must be made promptly. Raypak reserves the right to deny any warranty claim filed more than ninety (90) days after an incident covered by this Limited Warranty occurs. First, determine if your indirect water heater is "in-warranty" (that is, within the applicable Warranty periods that apply). You can determine your unit's warranty status by obtaining the complete model number, the complete serial number, and the date of original installation and accessing the "Warranty Verification" functionality on the Raypak website (www.Raypak.com) or contacting Raypak Warranty personnel (telephone number (805) 278-5300). To establish Lifetime Residential Limited Warranty coverage you must be able to provide proof that you purchased the indirect unit that is the subject of your warranty claim. If your indirect water heater is "in-warranty", refer to the installation and operation manual provided with it or contact the Raypak Technical Service Department (telephone number (805) 278-5300) to obtain the technical assistance you need to repair or replace your defective indirect unit. You may also use the plumber of your choice or select a plumber, or mechanical contractor, from your local Yellow pages to assist you – at your expense. Be prepared to provide the plumber, mechanical contractor, or Raypak Technical Service person you call with the complete model number, the complete serial number, and the date of original installation or the date of the owner's purchase of the defective indirect water heater in addition to an explanation of your indirect water heater problem. If an exact replacement unit is not available, Raypak will provide you with the current model of your indirect water heater. If government regulations or industry certification or similar standards require the replacement indirect water heater, or replacement component part, to have features not found in the malfunctioning indirect water heater, you will be charged for the difference in price represented by those required features. If you pay the price difference for those required features and/or to upgrade the size and/or other features available on a replacement new indirect water heater, you will also receive a complete new Limited Warranty (with the full applicable Warranty periods the original unit entitled you to) for the replacement indirect water heater. Raypak reserves the right to inspect, or require the return of, each indirect water heater or defective component part replaced under the terms and conditions of this Limited Warranty. Each "in-warranty" indirect water heater replaced under this Limited Warranty must be made available to Raypak (with the original rating label and all the component parts intact) in exchange for the replacement indirect water heater. Warranty compensation is subject to validation of "in-warranty" coverage by Raypak.

**Warranty claims personnel**

- To obtain warranty compensation for an "in-warranty" indirect water heater replacement, you must provide Raypak with: (at Raypak's option) either the indirect water heater replaced "in-warranty" (with the original rating label and all the component parts intact) or the complete original rating label (photocopies are not acceptable) removed from the indirect water heater replaced "in-warranty"; the complete model number and the complete serial number of the indirect water heater that replaced the original indirect water heater; and, the date the originally installed indirect water heater failed. The owner may also be required to provide proof he/she is the original owner/end user of the indirect water heater being replaced or the date of installation of the original indirect water heater to establish its "in-warranty" status.
- Warranty claim documentation should be mailed promptly to Raypak Inc., 2151 Eastman Ave, Oxnard, CA 93030.

**EXCLUSIVE WARRANTY• LIMITATION OF LIABILITY**

This Limited Warranty is the only Warranty given by Raypak Inc. (Raypak) for this indirect water heater. No one is authorized to make any other warranties on behalf of Raypak. ANY IMPLIED WARRANTIES, INCLUDING MERCHANTABILITY, OR FITNESS FOR A PARTICULAR PURPOSE, SHALL NOT EXTEND BEYOND THE APPLICABLE WARRANTY PERIODS SPECIFIED PREVIOUSLY. RAYPAK'S SOLE LIABILITY, WITH RESPECT TO ANY DEFECT, SHALL BE AS SET FORTH IN THIS LIMITED WARRANTY AND ANY CLAIMS FOR INCIDENTAL OR CONSEQUENTIAL DAMAGES (INCLUDING DAMAGE FROM WATER LEAKAGE) ARE EXCLUDED. Some states do not allow limitations on how long an implied warranty lasts, or for the exclusion of incidental or consequential damages, so the above limitations or exclusions may not apply to you. This Limited Warranty gives you specific legal rights, and you may also have other rights, which vary from state to state. We suggest you immediately complete the information below and retain this certificate of Limited Warranty in the event warranty service is required. Reasonable proof of original purchase and current ownership or the original date of installation of your indirect water heater (whichever is applicable) may be required to establish its "in-warranty" status. Otherwise, the effective Date of the Limited Warranty will be the date of manufacture plus ninety (90) days.

**DO NOT RETURN THIS DOCUMENT TO RAYPAK**

**KEEP IT WITH YOUR WATER HEATER OR BUSINESS RECORDS**

Name of Owner/Business Location: \_\_\_\_\_

Water Heater Installation Location Address: \_\_\_\_\_

Where this Water Heater is installed: \_\_\_\_\_

Date Water Heater was installed: \_\_\_\_\_

Name of Raypak Retailer: \_\_\_\_\_

Address of Retailer: \_\_\_\_\_

Telephone Number of Raypak Retailer: \_\_\_\_\_

Complete Model Number of Water Heater: \_\_\_\_\_

Complete Serial Number of Water Heater: \_\_\_\_\_

PRELIMINARY  
NOTES