



Ice Machine Parts List for Series Q1800 Models

QR1800A

QD1892N

QR1801W

QY1804A

QR1890N

QY1805W

QD1802A

QY1894N

QD1803W

Q1800 CONTROL BOX

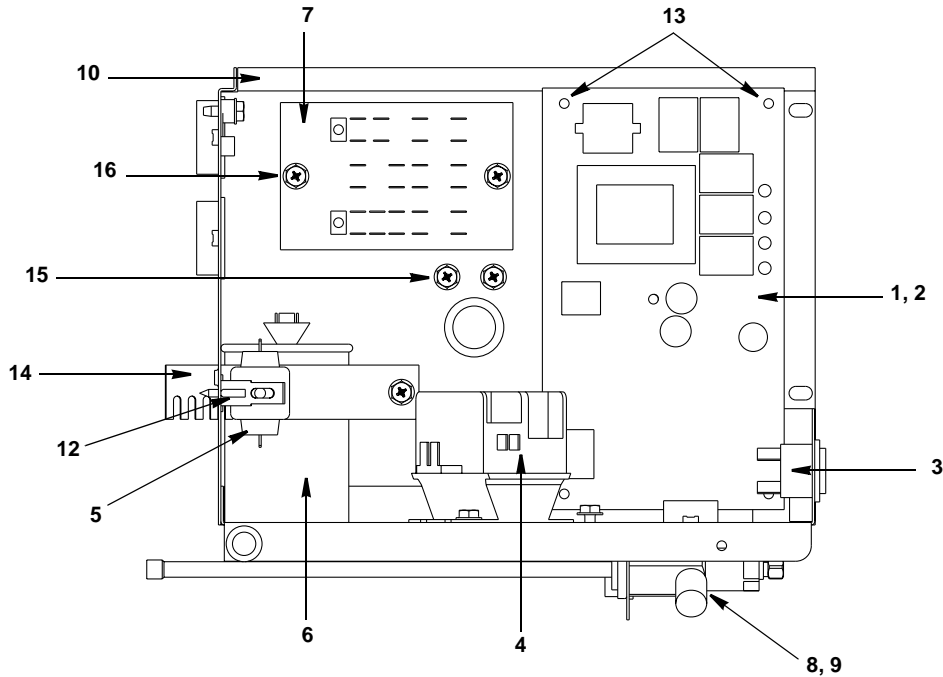

pt1176

DESCRIPTION

	PART NO.
1 Control Board (for use with all voltages)	† 76-2782-3
2 7 Amp Fuse – Mounted on Control Board	25-1100-3
3 Toggle Switch Only	23-0134-3
a. Toggle Switch with Wiring Harness Attached	20-3217-3
4 Contactor	
a. 208-230V/60 Hz/1 Ph or 230V/50 Hz/1 Ph	24-1035-3
b. 208-230V/60 Hz/3 Ph	† 20-0116-3
5 P.T.C.R. Compressor Starter.	85-0491-3
6 Compressor Run Capacitor	
a. Used with Compressor P/N 76-2689-3 (208-230V/60 Hz/1 Ph)	000001395
b. Used with Compressor P/N 76-2702-3 (230V/50 Hz/1 Ph)	† 000000028
7 Terminal Board with Wire Harness Attached	
a. 208-230V/60 Hz/1 Ph	20-3241-3
b. 208-230V/60 Hz/3 Ph	20-3243-3
c. 230V/50 Hz/1 Ph	20-3242-3
8 Refrigeration Service Valve Assembly	83-7324-3
Miscellaneous – Brackets, Screws, etc.	
9 Locknut Used to Mount Refrigeration Service Valves.	† 54-7503-9
10 Control Box	602559-1
11 Control Box Cover (Not shown)	† 76-2852-3
12 P.T.C.R. Compressor Starter Mounting Bracket	85-0495-3
13 Control Board Mounting Supports	43-0225-3
14 Capacitor Mounting Strap	602495-1
15 Screw, #10-24 x .50 Ground.	† 52-0216-9
16 Screw, #10-24 x .50	† 52-0206-9

† Refer to Cross Reference Guide

Q1800 EVAPORATOR COMPARTMENT

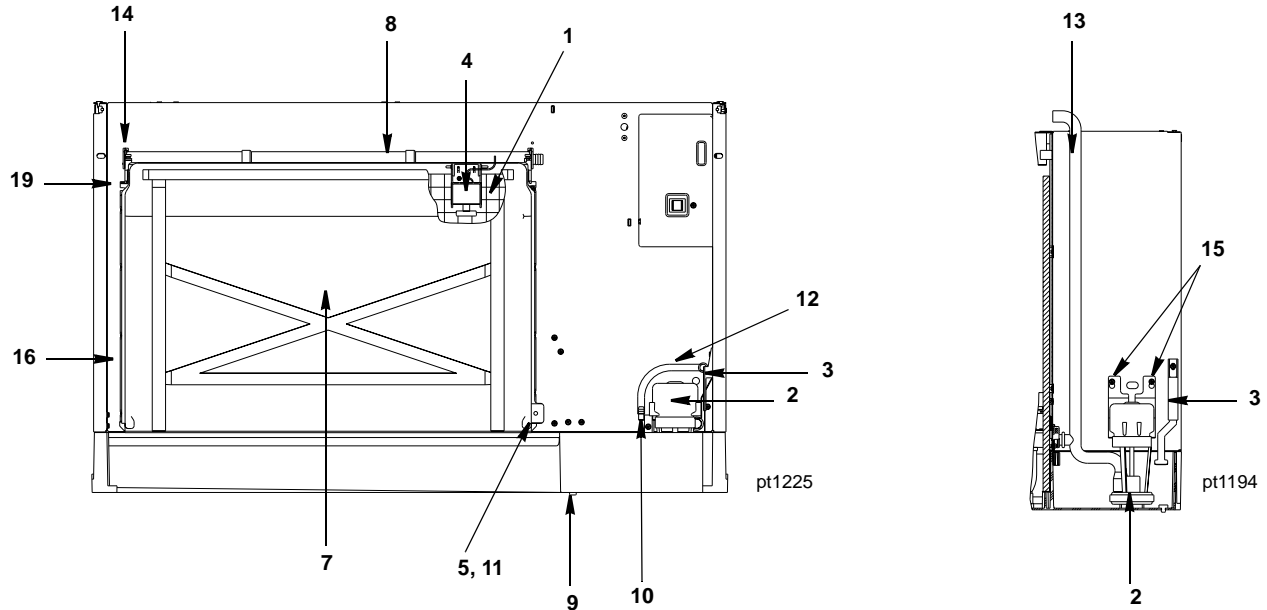

DESCRIPTION

	PART NO.
1 Evaporator Assembly	
a. Regular Cube	† 76-2696-9
b. Dice Cube	† 76-2697-9
c. Half Dice Cube	† 76-2698-9
2 Water Pump (208-230V/50-60 Hz)	† 14-8027-9
3 Water Level Probe	25-1129-3
4 Ice Thickness Control Probe	† 76-2781-3
5 Magnetic Bin Switch (Mounted to Evaporator)	† 23-0148-3
6 Water Flow Clamp – Use on Regular Cube Evap. Only (Not shown)	76-2054-3
7 Water Curtain	† 40-0474-3
8 Water Distribution Tube	43-0322-3
9 Water Trough Drain Plug	† 43-0062-9
10 Water Inlet Flow Tube	43-0388-3
Miscellaneous – Brackets, Screws, etc.	
11 Water Curtain Magnet with Attachment Clip	† 76-2802-3
12 Water Inlet Tubing .375 ID	44-2131-3
13 Tubing (Water Pump Out)	44-2117-3
14 Screw, #8-32 x .63 Nylon Water Distribution Tube Mounting	† 50-0001-3
15 Screw, 10-24 x .50	† 52-0206-9
16 Screw, 10-24 x .750 – Used to Mount Evaporator	† 52-0218-9
17 Base and Water Trough Repair Kit (Not shown)	† 76-2806-3
18 Evaporator Top Molding and Gasket Assembly (Not shown)	76-2801-3
19 Water Curtain Pin Assembly	† 76-2856-3

† Refer to Cross Reference Guide

Q1800 REFRIGERATION COMPARTMENT – COMMON PARTS

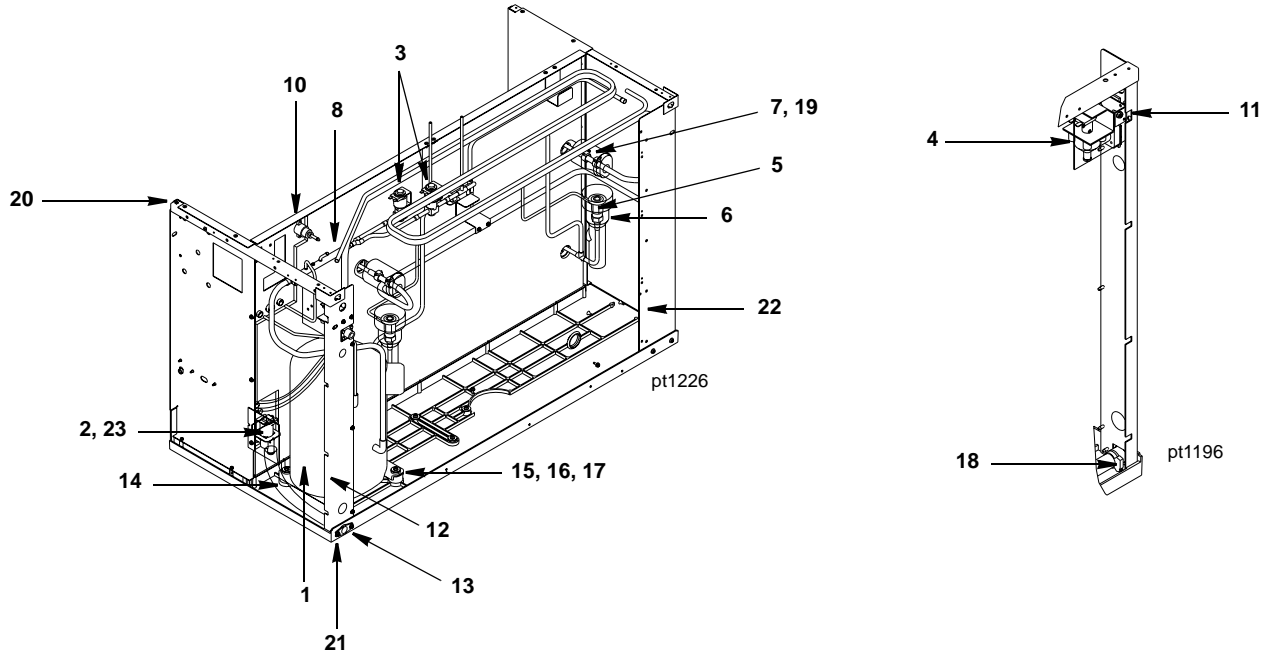

DESCRIPTION

PART NUMBER

1	Compressor	
	a. 208/230V/60 Hz/1 Ph	† 76-2689-3
	b. 208/230V/60 Hz/3 Ph	† 76-2690-3
	c. 230V/50 Hz/1 Ph	† 76-2702-3
	d. 415V/50 Hz/3 Ph (Remote Ice Machines Only)	† 76-2703-3
2	Water Dump Valve	
	a. Dump Valve Coil Only, 208/230V 50/60 Hz	000001768
	e. Dump Valve Rebuild Kit	No Longer Available
3	Hot Gas Valve	
	a. Hot Gas Valve Including 208/230V 50/60 Hz Electrical Coil (Danfoss)	† 76-3010-1
	b. Hot Gas Valve 208/230V 50/60 Hz Coil Only Danfoss	20-0177-3
	c. Hot Gas Valve 208/230V 50/60 Hz Coil Only Alco	† 24-0448-3
4	Water Inlet Valve	
	a. Water Inlet Valve Including 208/230V 50/60 Hz Coil	76-0113-3
5	Expansion Valve	† 76-0022-3
6	Expansion Valve Body Insulation Boot	
	a. Alco	40-0721-3
	b. Danfoss	40-0036-3
7	Expansion Valve Bulb Insulation Boot	40-0720-3
8	Manifold Strainer (in front of hot gas valve)	82-5097-3
9	Water Pump Electrical Wire Lead (Not shown)	† 20-7810-3
10	High Pressure Cut-out (Manual Reset)	† 23-5536-9
10	High Pressure Cut-out (Auto Reset)	† 20-0124-3
Miscellaneous – Brackets, Screws, etc.		
11	Water Inlet Valve Mounting Bracket	602354-1
12	Right Corner Post Weldment	602204-1
13	Water Drain Female Wing Adapter	87-0608-3
14	Water Drain Vinyl Tubing, .625 ID	† 44-2038-3
15	Compressor Mounting Rubber Grommet	† 85-0485-9
16	Compressor Mounting Washer	† 55-7341-9
17	Compressor Mounting Screw	† 50-1230-9
18	Clamp, Water Drain	† 56-5070-9
19	Clamp, Expansion Valve Bulb	† 56-5052-9
20	Screw, #10-24 x .50	† 52-0209-9
21	Screw, #10-24 x .75	† 52-0218-9
22	Left Corner Post Weldment	604514-1
23	Dump Valve Mounting Bracket	601597-1
24	Terminal Block	20-0614-3

† Refer to Cross Reference Guide

Q1800 REFRIGERATION COMPARTMENT – AIR-COOLED

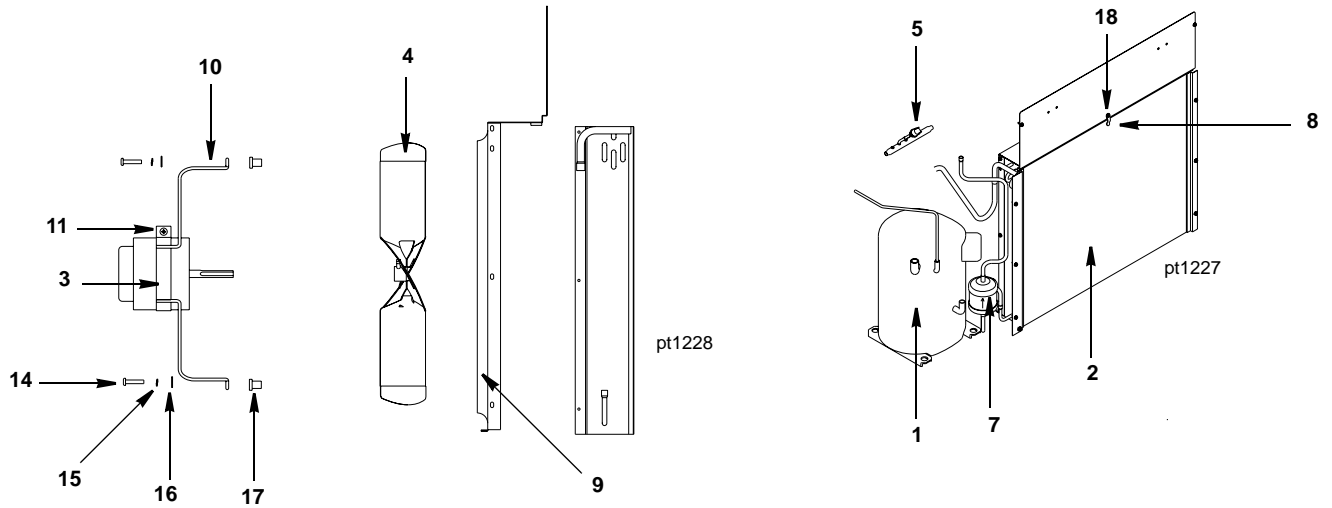

DESCRIPTION

	PART NO.
1 Compressor (Refer to COMMON PARTS Page)	Page 4
2 Air Condenser	88-5129-3
3 Fan Motor (208-230V/60 Hz or 230V/50 Hz)	† 76-2673-3
4 Fan Blade	24-1611-3
5 Fan Cycling Control	† 20-0127-3
6 Air Filter (Not shown)	40-4025-3
7 Drier	† 89-3027-9

Miscellaneous – Brackets, Screws, etc.

8 Air Filter Clip	† 56-5069-9
9 Fan Shroud	† 604516-1
10 Fan Motor Mounting Bracket	34-0669-3
11 Fan Motor Mounting Screw	† 50-3358-9
12 Fan Motor Mounting Lockwasher	† 55-4510-9
13 Fan Motor Mounting Hexnut	† 54-2952-9
14 Fan Bracket Mounting Screw	† 50-3358-9
15 Fan Bracket Mounting Lockwasher	† 55-4510-9
16 Fan Bracket Mounting Flatwasher	† 55-7305-9
17 Fan Bracket Mounting Rubber Wellnut	† 54-2955-9
18 Screw, #10-24 x .50	† 52-0206-9

† Refer to Cross Reference Guide

Q1800 REFRIGERATION COMPARTMENT – WATER-COOLED

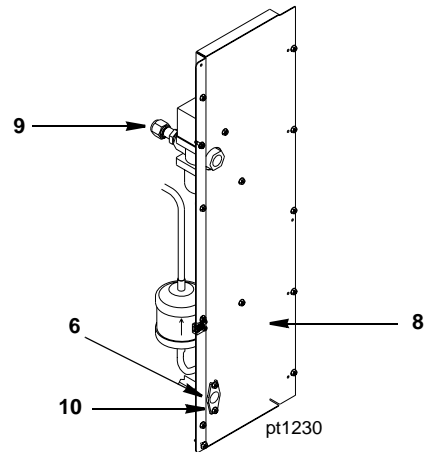
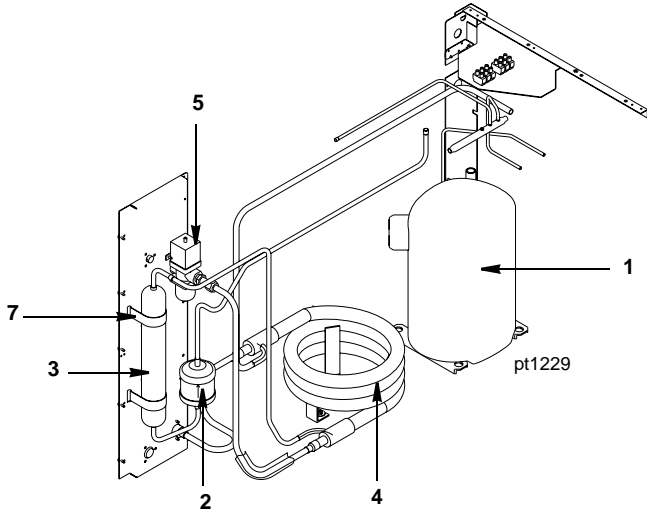

DESCRIPTION

	PART NO.
1 Compressor (Refer to COMMON PARTS Page)	Page 4
2 Drier	† 89-3027-9
3 Receiver	89-0035-3
4 Water-cooled Condenser	† 000001508
5 Water Regulating Valve	83-7212-3
6 Water Drain Female Wing Adapter	87-0608-3

Miscellaneous – Brackets, Screws, etc.

7 Receiver Strap	600054-1
8 Back Panel	601905-1
9 Water Coupling	83-3419-3
10 Screw, #10-24 x .50	† 52-0206-9

Q1800 REFRIGERATION COMPARTMENT – REMOTE

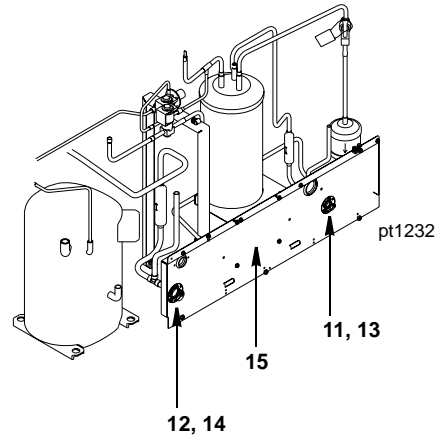
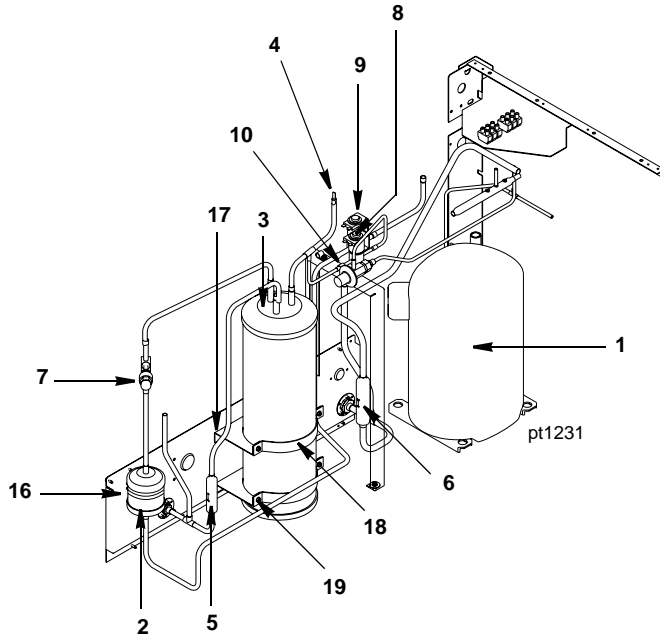

DESCRIPTION

DESCRIPTION	PART NO.
1 Compressor (Refer to COMMON Parts)	Page 4
2 Drier	† 89-3027-9
3 Receiver	† 76-2958-3
4 Safety Soft Plug	† 628451-9
5 Magni-Check Valve	† 83-7314-9
6 Magni-Check Valve	† 83-7315-9
7 Refrigeration Service Valve	† 83-7316-9
a. Cap for Refrigeration Service Valve	56-5075-3
8 Harvest Pressure Regulating Solenoid (HPR) Valve	
a. HPR Valve Including 208/230V 50/60 Hz Electrical Coil (Danfoss)	† 76-3006-1
b. HPR Valve 208/230V 50/60 Hz Coil Only Danfoss	20-0177-3
c. HPR Valve 208/230V 50/60 Hz Coil Only Alco	† 24-0448-3
9 Liquid Line Solenoid (LLS) Valve	
a. LLS Valve Including 208/230V 50/60 Hz Electrical Coil	76-3010-1
b. LLS Valve 208/230V 50/60 Hz Coil Only Alco	† 24-0448-3
10 Harvest Pressure Regulating Valve (HPR)	† 83-6779-3
11 Coupling – Male, 5/8-18	† 83-6034-3
12 Coupling – Male, 1-1/6-12	† 83-6035-3
Miscellaneous – Brackets, Screws, etc.	
13 Coupling Mounting Flange for 5/8-18	83-6005-3
14 Coupling Mounting Flange for 1-1/16-12	83-6006-3
15 Back Panel	601905-1
16 Drier Plastic Tie	† 56-5035-9
17 Receiver Mounting Bracket	600056-1
18 Receiver Mounting Strap	630721-4
19 Screw, #10-24 x .50	† 52-0206-9

† Refer to Cross Reference Guide

Q1800 PANELS

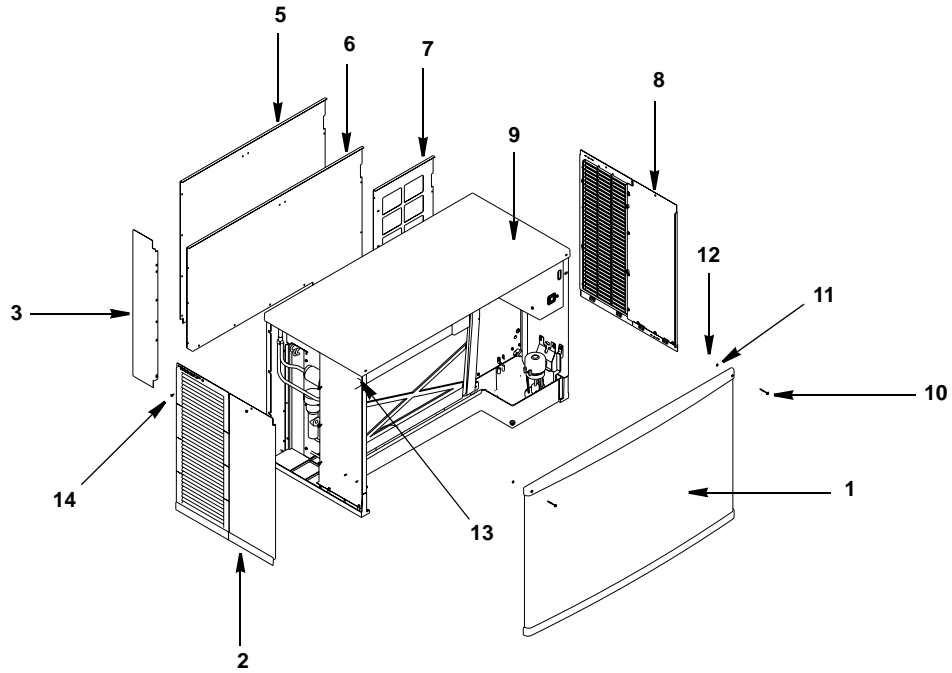

pt1233

DESCRIPTION

DESCRIPTION	PART NO.
1 Front Panel Assembly	76-2879-3
2 Left Side Panel	† 76-2859-3
3 Air Baffle	602376-1
4 Air Filter (Not shown)	40-4025-3
5 Back Panel, Water	602599-1
6 Back Panel, Remote	602607-1
7 Back Panel, Air	604517-1
8 Right Side Panel	† 76-2860-3
9 Top Cover	43-0332-3

Miscellaneous – Brackets, Screws, etc.

10 Front Cover Screw	† 51-1901-9
11 Front Cover Washer	† 55-7338-9
12 Front Cover Screw Retainer	† 56-4827-9
13 Speed Nut Assembly to Mount Front Cover	† 54-7303-9
14 Screw, #10-24 x .50 Flat	† 52-0209-9
15 Extruded Tape (Not shown)	† 92-0250-9
16 Front Top Support (Not shown)	601464-1

NOTE: Items 10, 11, 12 and 13 can be ordered as assembly 76-2898-3.

JC1895 REMOTE CONDENSER (USED WITH Q1800 REMOTE ICE MACHINES)

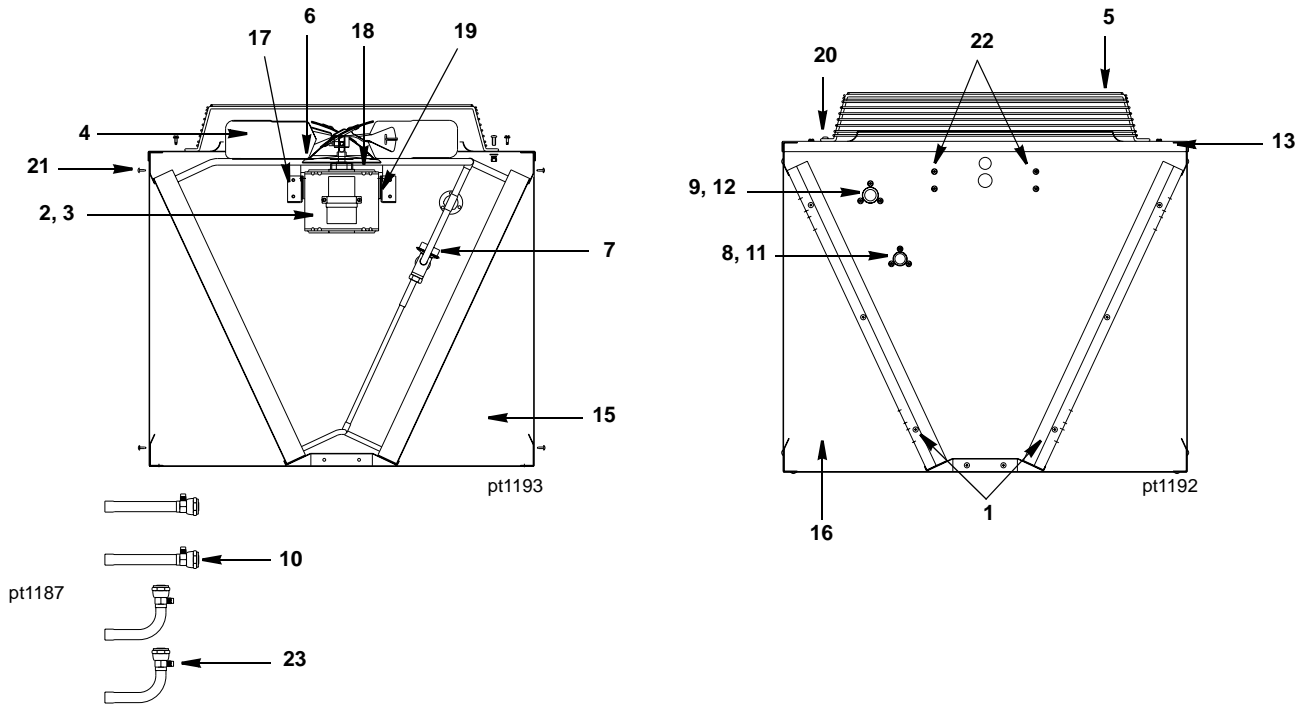

DESCRIPTION

	PART NO.
1 Air Condenser (uses two)	† 88-5089-9
2 Fan Motor (208-230V 50/60 Hz/1 Ph)	† 76-2941-3
3 Fan Motor Run Capacitor (Emerson)	85-0458-3
3 Fan Motor Run Capacitor (Magnatec)	85-0352-3
4 Fan Blade	24-1611-3
5 Fan Guard	34-0064-3
6 Rain Slinger	24-1505-3
7 Head Pressure Control	83-6809-3
8 Coupling – Male, 5/8-18	† 83-6034-3
9 Coupling – Male, 1-1/6-12	† 83-6035-3
10 Female Line Set Coupling Kit (Sold as Finished Goods Sales Kit)	Sales K0129

Miscellaneous – Brackets, Screws, etc.

11 Coupling Mounting Flange (for 5/8-18)	83-6006-3
12 Coupling Mounting Flange (for 1-1/16-12)	83-6005-3
13 Top Cover	601789-1
14 Intentionally Left Blank	
15 Panel – Rear	† 601788-1
16 Panel – Front	† 601787-1
17 Fan Motor Mounting Bracket	† 601768-1
18 Electrical Box Cover	† 601776-1
19 Fan Motor Mounting Screw (5/16-18 x 5/8)	† 50-3565-9
a. Fan Motor Mounting Flatwasher	† 55-7309-9
b. Fan Motor Mounting Lockwasher	† 55-7313-9
c. Fan Motor Mounting Hexnut	54-2975-9
20 Fan Guard Mounting Screw (1/4-20 x 5/8)	† 50-3345-9
a. Fan Guard Mounting Flatwasher	† 55-7304-9
b. Fan Guard Mounting Lockwasher	† 55-4511-9
c. Fan Guard Mounting Hexnut	† 54-2952-9
21 Panel/Condenser Mounting Screw (#8 x 1/2)	† 51-2153-9
a. Panel/Condenser Mounting Lockwasher	† 55-4459-9
22 Screw (#10-24 x 1/2)	† 52-0206-9
23 Valve Cores (used in linesets)	76-2684-3
24 Legs (Not shown)	† 601769-1

† Refer to Cross Reference Guide

INTENTIONALLY LEFT BLANK