



# Q-Matic Ovens Owners Manual



For models – Q-36, Q-36W, Q-55 & Q-80  
Includes Hybrid Models



A Marmon Retail Services™ Company

# Table of Contents

Introduction	3
Radiant Heat Ovens	3
Oven Cross Section	4
Specifications	5
Installation Instructions	6
Delivery and Inspection	7
Oven Location and Installation	9
Oven Assembly	10
Conveyor Installation	11
Wire Belt Installation	12
Speed Control Wiring Diagram	14
Gas Piping	19
Piping Size Requirements	20
Electrical Connections	21
Component Locations	22
Oven Start-up	24
Temperature Control	25
Oven Shut Down	40
Guidelines for Cooking Adjustments	41
Cleaning and Maintenance	45
Troubleshooting	46
Electrical Wiring Diagrams	48
Product Test Form	52
Warranty	53

**FOR YOUR SAFETY DO NOT STORE GASOLINE OR OTHER FLAMMABLE VAPORS AND LIQUIDS IN THE VICINITY OF THIS OR ANY OTHER APPLIANCE.**

Instructions to be followed in the event that the user smells gas must be posted in prominent location. This information may be obtained by consulting your local gas supplier.

The information contained in this manual is important for the proper installation, use and maintenance of this oven. Adherence to prescribed procedures and instructions will result in a satisfactory baking results and long trouble-free service. Please read this manual carefully and retain it for future reference.

# **Introduction**

## **The Q-Matic Radiant Ovens**

**Q-Matic is an automatic piece of equipment that can hold and control the heat applied to a product and the cooking time. Once the cooking time and temperature has been established for a certain type of product, i.e. pizza, the operator just turns on the switches in the morning and off at the end of the day!**

**This revolutionary new equipment uses infrared heat instead of forced convection. Infrared heat is produced by gas infrared metal burners that can use natural gas, butane or any other manufactured combustion gas. By using infrared heat, this oven combines the advantages of a deck oven and a conveyor oven.**

**Since there is plenty of bottom heat capacity, the oven is very easily adjustable for any type of crust you may have. Also because of its versatility, Q-Matic is better suited for independent pizza operations than the forced convection ovens. The noisiness of forced convection is also eliminated since the Q-Matic ovens do not employ any blowers to circulate air. For your convenience, the oven has also been designed with a easy access panel at the front of the oven for quick efficient service.**

**Please take the time to read the following operating instructions carefully. They are the key to successful use of the Q-Matic oven.**

# Oven Cross Section

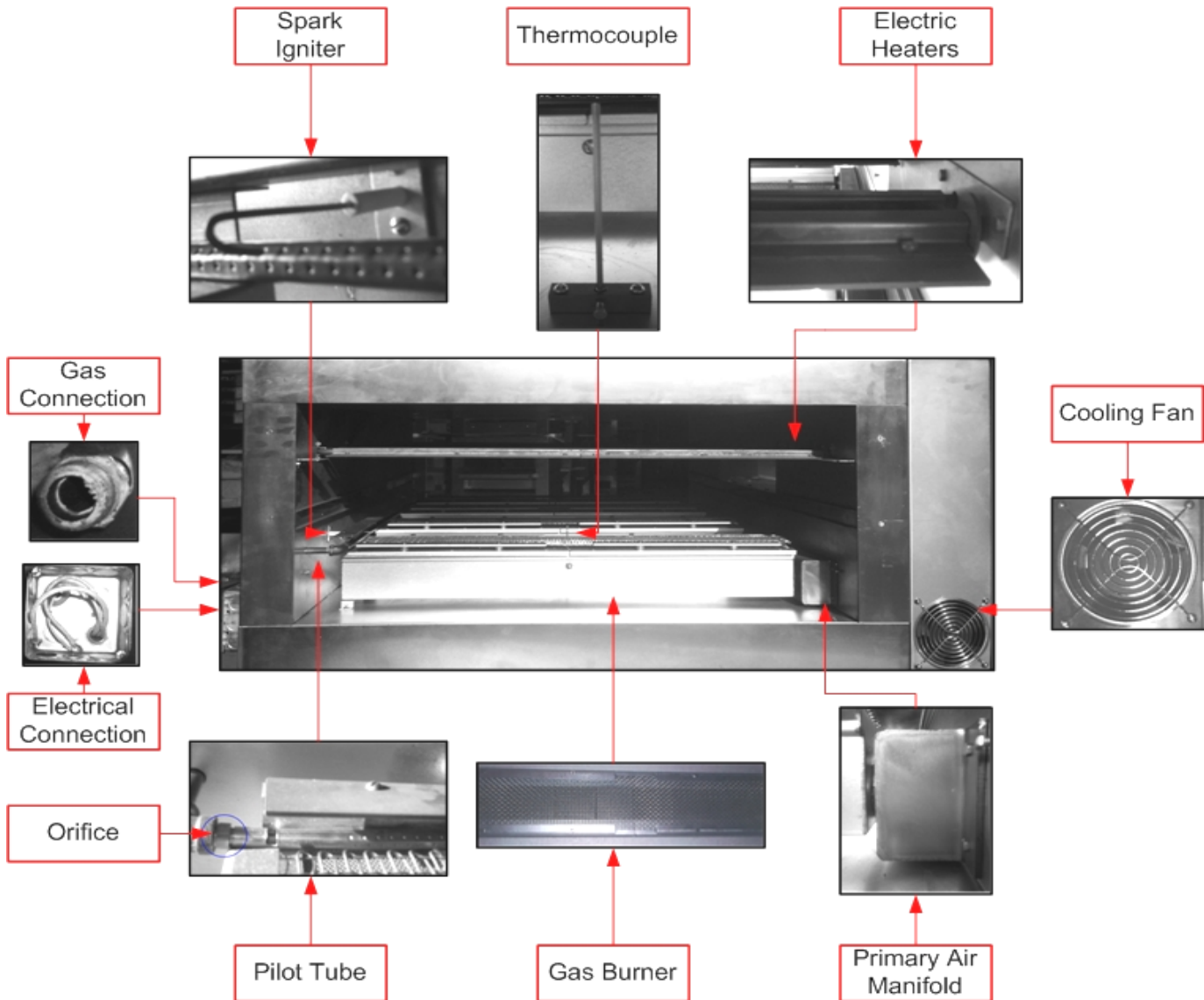

# Oven Specifications

<b>Model</b>	<b>Q-36</b>	<b>Q-36H</b>	<b>Q-36W</b>	<b>Q-36WH</b>	<b>Q-55</b>	<b>Q-80</b>
Belt Width	24"	24"	30"	30"	32"	32"
Cooking Zone Length	36"	36"	36"	36"	55"	80"
Cooking Area	5.3 Sq. Ft.	5.3 Sq. Ft.	7.5 Sq. Ft.	7.5 Sq. Ft.	12.5 Sq. Ft.	15.3 Sq. Ft.
Floor Space	64" x 36"	64" x 36"	64" x 42"	64" x 42"	91" x 54"	116" x 54"
Maxium Operating Temperature	550° F	550° F	550° F	550° F	550° F	550° F
Maxium Energy Output	90,000 BTU/HR	90,000 BTU/HR	120,000 BTU/HR	120,000 BTU/HR	160,000 BTU/HR	240,000 BTU/HR
Operating Range	40,000 - 60,000 BTU/HR	70,000 BTU/HR	50,000 - 90,000 BTU/HR	80,000 BTU/HR	60,000 - 90,000 BTU/HR	80,000 - 120,000 BTU/HR
Power Requirements	120/208 - 230/150-60 HZ 3 Wire, 15amp	208 - 240/3, 50-60 HZ 3 Wire, 35 amp	120/208 - 230/150-60 HZ 3 Wire, 25amp	208 - 240/3, 50-60 HZ 3 Wire, 35 amp	120/208 - 230/150-60 HZ 3 Wire, 40amp	120/208 - 230/150-60 HZ 3 Wire, 50amp
Product Clearance	3.5 "	3.5 "	3.5 "	3.5 "	3.5 "	3.5 "
Gas Supply	3/4"	3/4"	3/4"	3/4"	3/4"	3/4"
Estimated Crated Weight	410 lbs.	410 lbs.	480 lbs.	480 lbs.	520 lbs.	810 lbs.

# Installation Instructions

**THE INSTALLATION INSTRUCTIONS CONTAINED  
HEREIN ARE FOR THE USE OF QUALIFIED  
INSTALLATION AND SERVICE PERSONNEL  
ONLY. INSTALLATION OR SERVICE BY OTHER  
THAN QUALIFIED PERSONNEL MAY RESULT  
IN DAMAGE TO THE OVEN AND/OR TO  
THE OPERATOR.**



Qualified installation personnel are individuals, a firm, A corporation, or a company which either person or through a representative are engaged in, and are responsible for:

The installation or replacement of gas piping or the Connection, installation, repair or servicing of equipment, Who are experienced with such work, familiar with all Precautions required, and have complied with all Requirements of state and local authorities having jurisdiction. Reference: National Fuel Gas Code, NFPA 54-1980 and ANSI Z23.1-1980 Section 1.4.



The installation of electrical wiring from the electric Meter, main control box or service outlet to the electric Appliance. Qualified installation personnel must be experienced In such work, be familiar with all precautions required and have Compiled with all requirements of state or local authorities having Jurisdiction. Reference: National Electric Code, NFPA70-1981

Canadian installations should conform to "Installation Codes of Gas Burning Appliance and Equipment" CAN-1-B149 and B149.2 and/or local codes.



# Delivery and Inspection

All Q-Matic Technologies ovens are shipped in containers to prevent damage. When tendered to the carrier, each unit was carefully inspected and packed.

Upon delivery of your new oven:

Inspect the shipping container for any external damage. Any evidence of damage should be noted upon the delivery receipt which must be signed by the driver. If any external damages are noted, unpack immediately and check for internal damage. Carriers will accept claims for concealed damage if notified within three days of delivery if the shipping container is retained for inspection. Q-Matic Technologies cannot assume responsibility for damages occurred during transportation. All shipments are FOB Gurnee, Illinois. We are, however, prepared to assist you in filing a claim if necessary.

The oven can now be moved to the installation site. Check the list below with Figure 1 to be sure all items were received.

<b>Qty.</b>	<b>Part Description</b>	<b>Fig. 1 No.</b>
1	Main Oven Body	1
4	Oven Support Assembly	2
1**	Left Conveyor Belt Support Assembly	3
1	Right Conveyor Belt Support Assembly	4
1*	Rolled Wire Belt	6
1	Left Crumb Pan	7
1	Right Crumb Pan	8
1*	Conveyor Drive Chain Cover	9
1	Conveyor Belt Inner and Outer Master Links	10
1	Top End Plugs	11
1	Owner's Manual	12

Two of these items are included with dual belt models.

Note: for Q-Matic 80 a middle support section is also included.

packet containing 3/8-16 bolts (for oven supports) and product stop not shown.

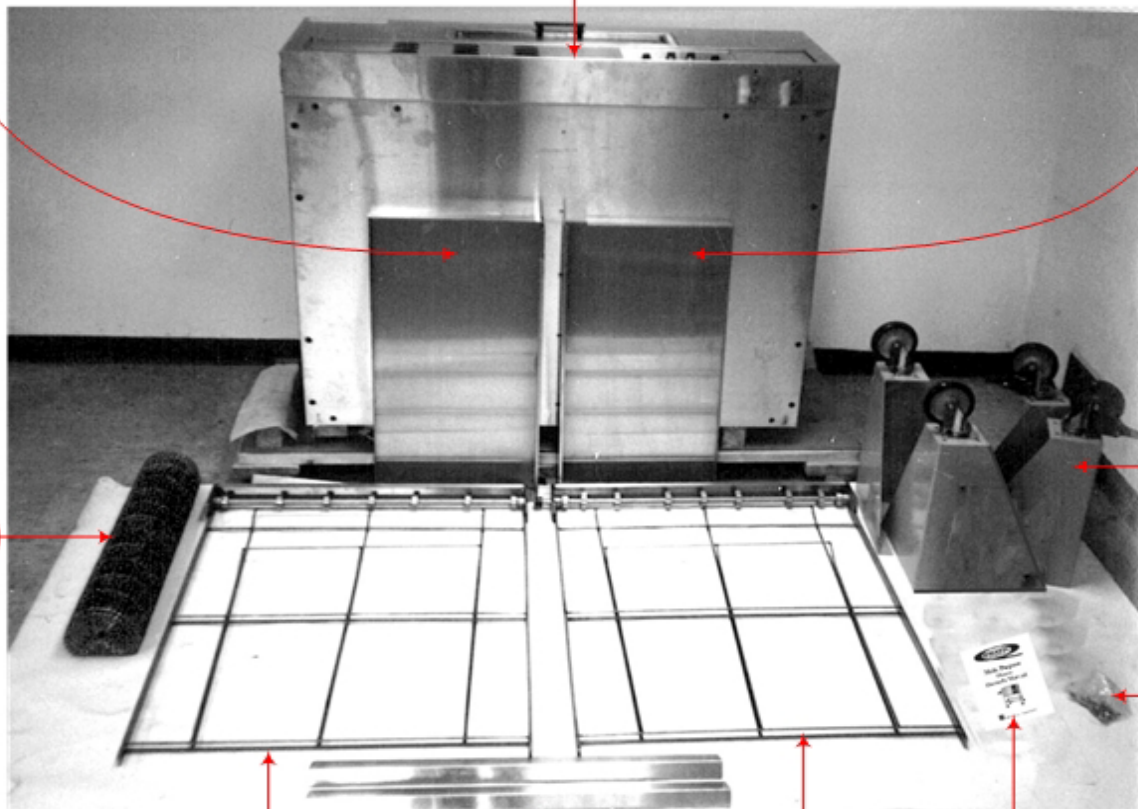

1

8

7

6

2

6

10

4

11

3

12

# Oven Location and Installation

The well planned and proper placement of the oven will result in long term operator convenience and satisfactory performance. It is therefore urged that adequate thought to be given to the location of the oven prior to its delivery and installation.

Place the oven in an area that is free of drafts and is accessible for proper operation and servicing. A minimum of twenty (20) inches from the oven body sides and eleven (11) inches from the body oven back must be maintained from any combustible construction. In addition, a minimum of thirty-eight (38) inches from oven body's left side and twenty-eight (28) inches from oven body back must be available for operation and servicing.

It is also essential that provisions for an adequate air supply to the oven be maintained and that natural flow for combustion and ventilation air not to be obstructed in any way if proper operation is to be assured. DO NOT use fans around the oven!!! The oven tunnel is not pressurized, therefore any drafts direct to the tunnel will disrupt the heat pattern in the oven, inducing inconsistent cooking.

The necessity of a properly designed and installed ventilation system cannot be overemphasized.

Such a system will allow the oven to function properly while removing unwanted vapors and products of combustion from the operating area.

Failure to properly vent the oven can be hazardous to the health of the operator. It will also result in operational problems, unsatisfactory baking, and possible damage to the equipment. Damages sustained as a direct result from improper ventilation will not be covered by the Manufacturer Warranty.

This appliance must be vented with a properly designed mechanically driven exhaust hood. The hood should be sized to completely cover the equipment, plus an overhang of at least six (6) inches in all sides not adjacent to the wall. The distance of the floor from the lower edge of the hood should not exceed seven (7) feet. The capacity of the hood should be sized appropriately and provision should be made for adequate makeup air. Should be noted that Q-Matic ovens do not use blowers and therefore the tunnel is not pressurized, the spillage of hot air into the kitchen is substantially reduced and subsequently the need for powerful exhaust. Refer to your local ventilation codes to establish the right proportion between exhaust and make-up air.

# Oven Assembly

1. Connect the oven supports to the main body using the 3/8-16 bolts, making sure that the casters with brakes are facing the front of the oven.

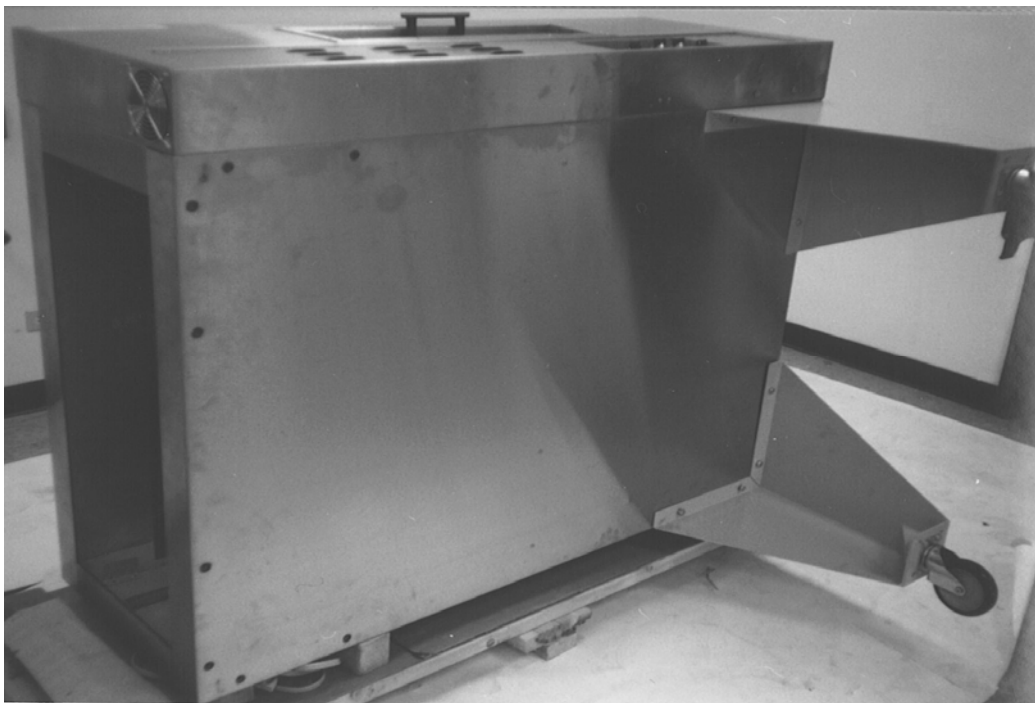

Figure 2

2. Carefully place oven onto casters. (It will be necessary to have several persons to lift the oven off the pallet and set in on the casters.) Engage brakes on the front casters.

3. Slide right conveyor belt support (with sprocket on end of shaft) into the support tracks. Sprocket must be located next to the control box after being pushed into the ovens. Refer to Figure 3.

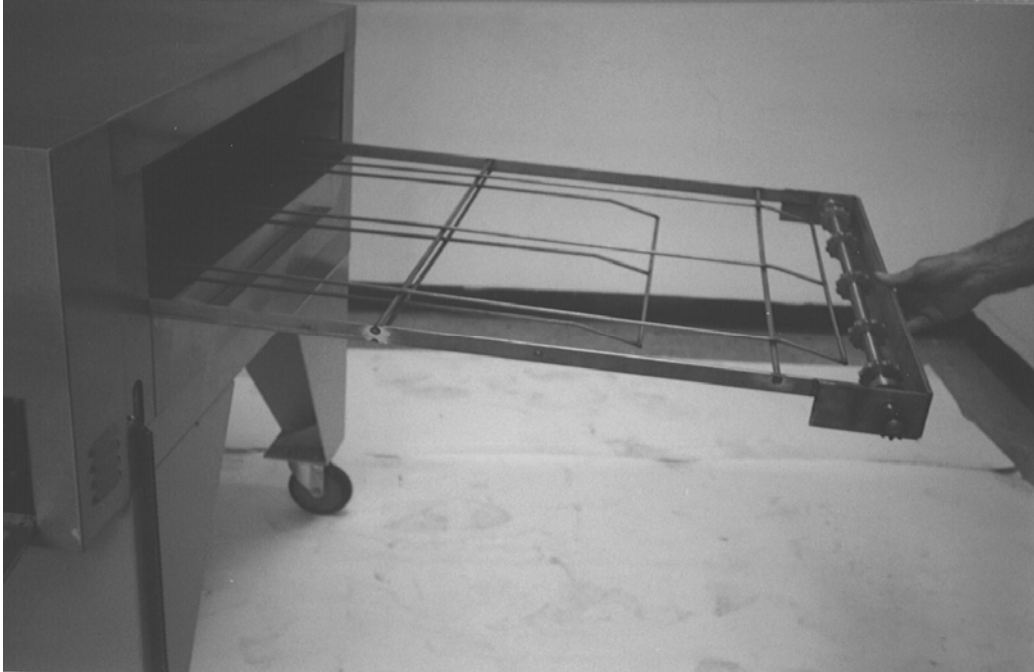

Figure 3

4. Cut the plastic tie holding the drive chain around the motor sprocket through the opening in the main body and install the drive chain around the sprocket on the conveyor belt support. Pull belt support back to tighten chain. Refer to Figure 4. (Dual belt model will have a sprocket and chain on both sides.)



Figure 4

5. Install the conveyor support stop using the ¼-20 hex head screw.  
Refer to Figure 5.



Figure 5

6. Install the drive chain cover to the right side and tighten screws.  
Refer to Figure 6.

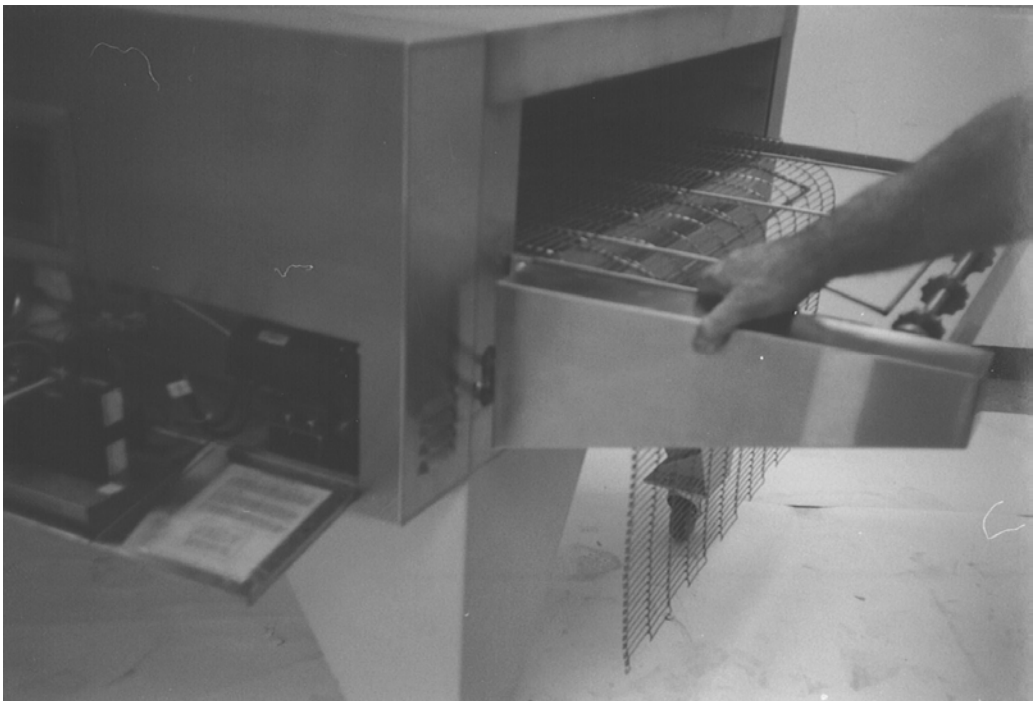

Figure 6

7. Slide left conveyor belt support into the support tracks until it touches the right support.

8. Installation of wire conveyor belt.

**Note:** Unless specified otherwise, conveyor travel is factory set for left to right operation when facing the front of the oven. If a change of direction is required, the polarity of the drive motor must be reversed. Simply interchange the black and white motor leads at the D.C. Controller located in the control panel. Refer to Figure 8,9. In addition, the conveyor belt must be installed from the right side of the oven vs. left side.

Before threading the conveyor belt, note that the belt has loops at both ends. These loops must ride backward on the top of the conveyor support to avoid any catching. Also note that the belt has a top and bottom. The bottom is always smooth. Refer to Figure 7.

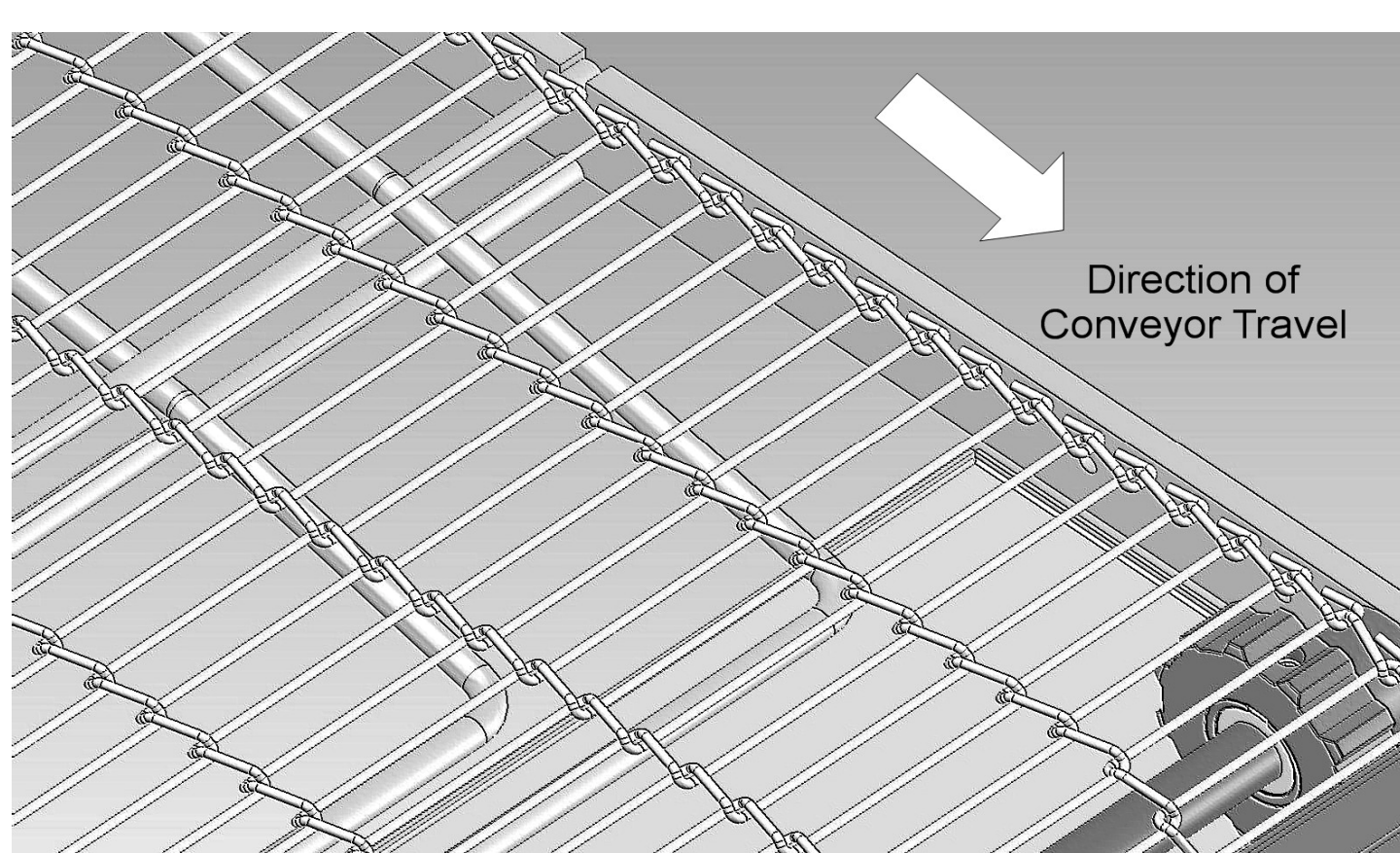

Figure 7

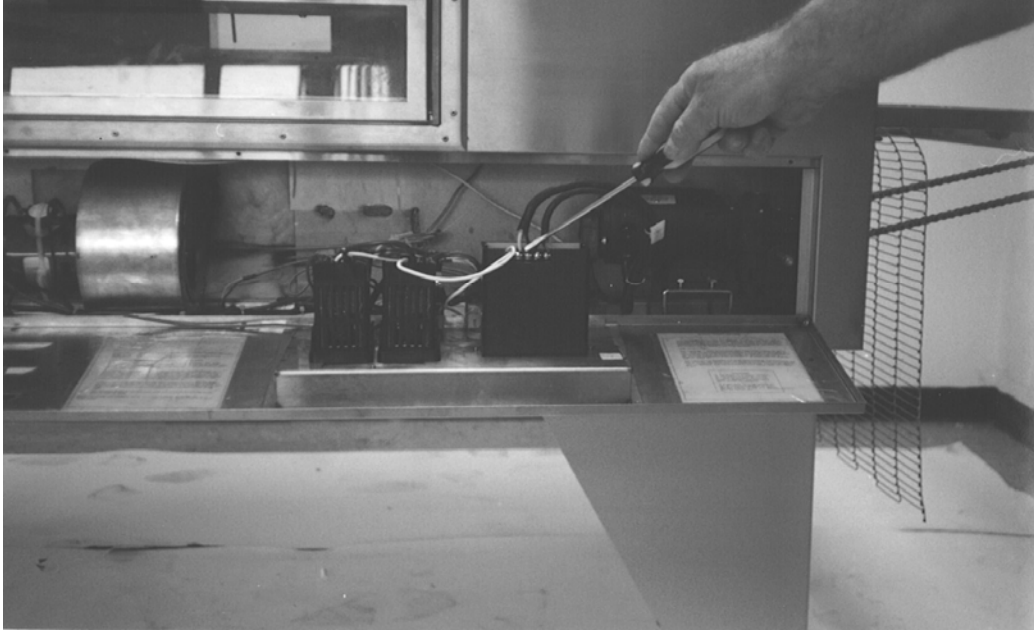

Figure 8

## Wiring Diagram – Speed Control

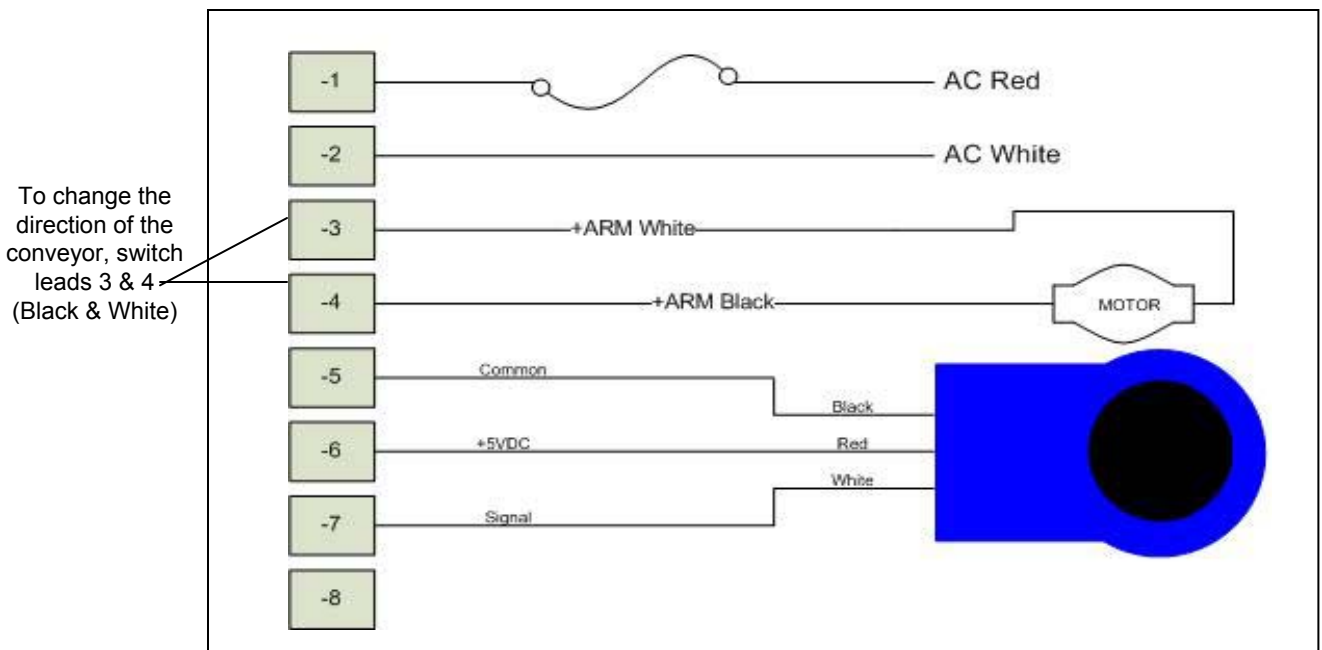

Figure 9

Thread wire belt starting from the left side of the oven, lower lever first. After pushing belt through, on the lower level (leave about one foot hanging out on right side), take remainder of belt looping it around left shaft, and push through upper lever.

Refer to Figures 10, 11 and 12.

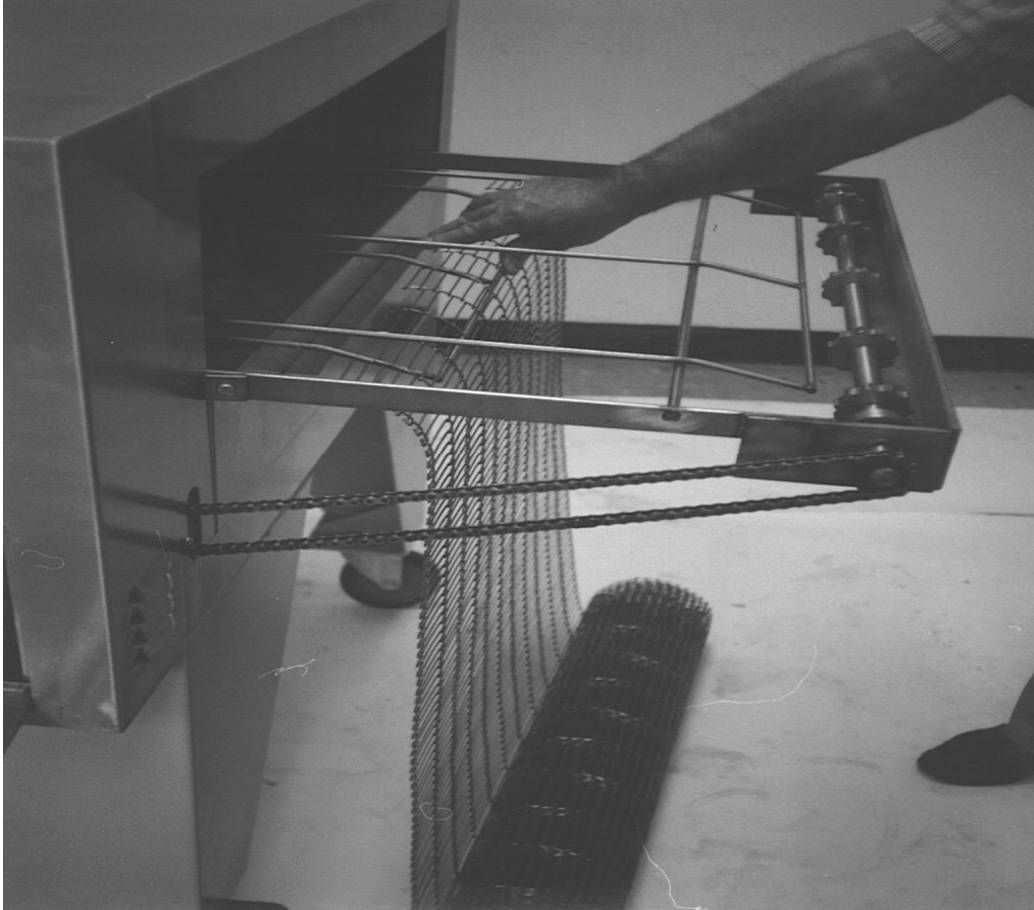

Figure 10

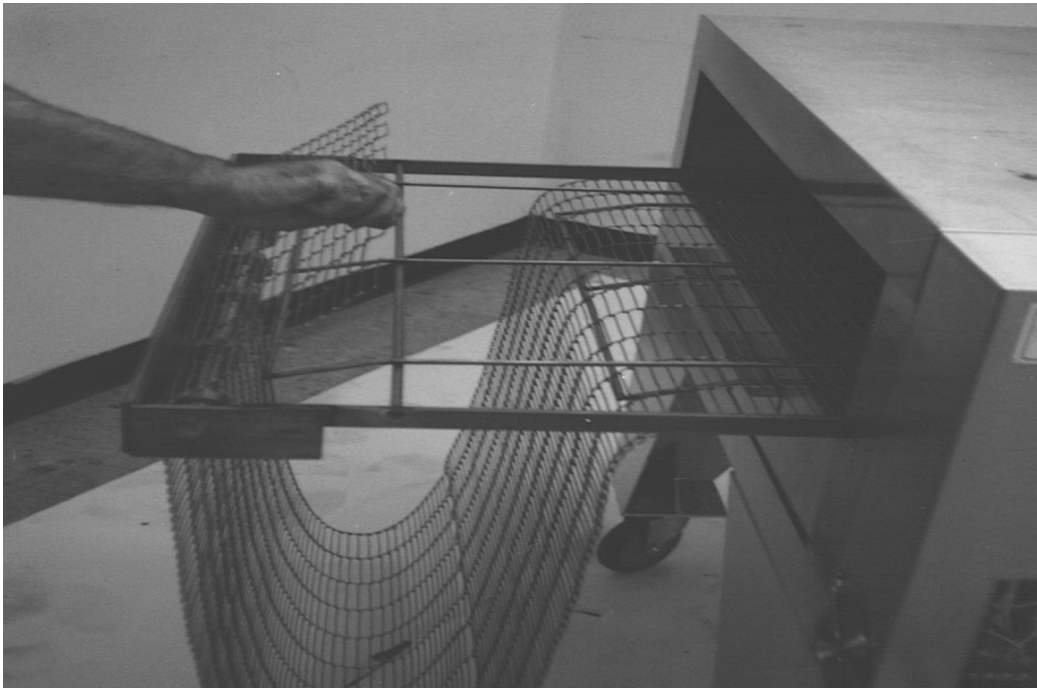

Figure 11

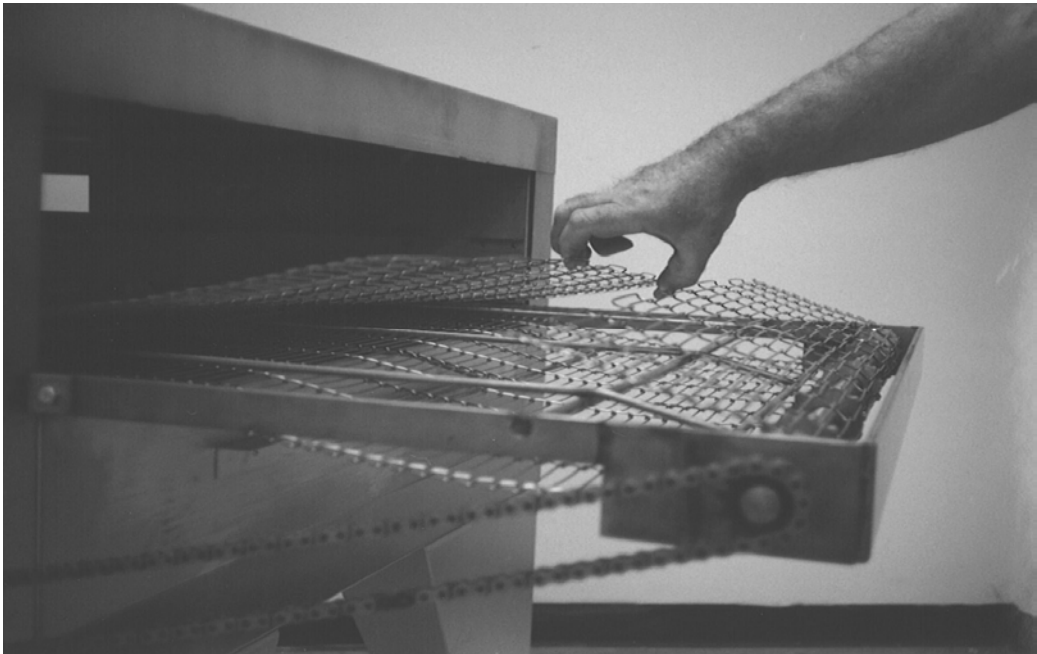

Figure 12

The two ends of the belt should be approximately 6-9 inches past the right shaft on the upper level of belt support. Install inner and outer master links. Refer to Figure 13. Note that additional master links can be made out of a full belt link in case the original master links are lost or misplaced.

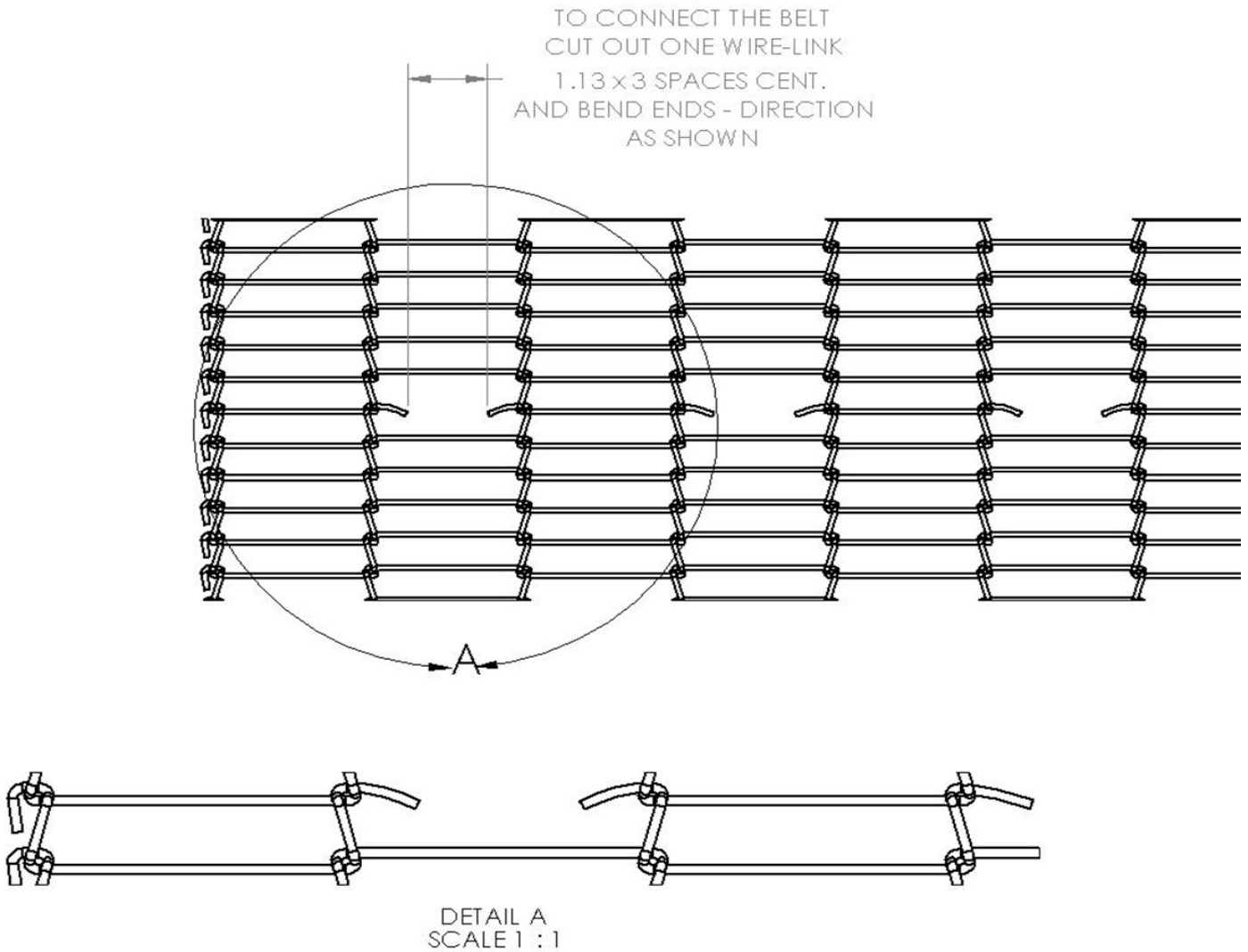

Figure 13

Install the right crumb pan. Refer to Figure 14

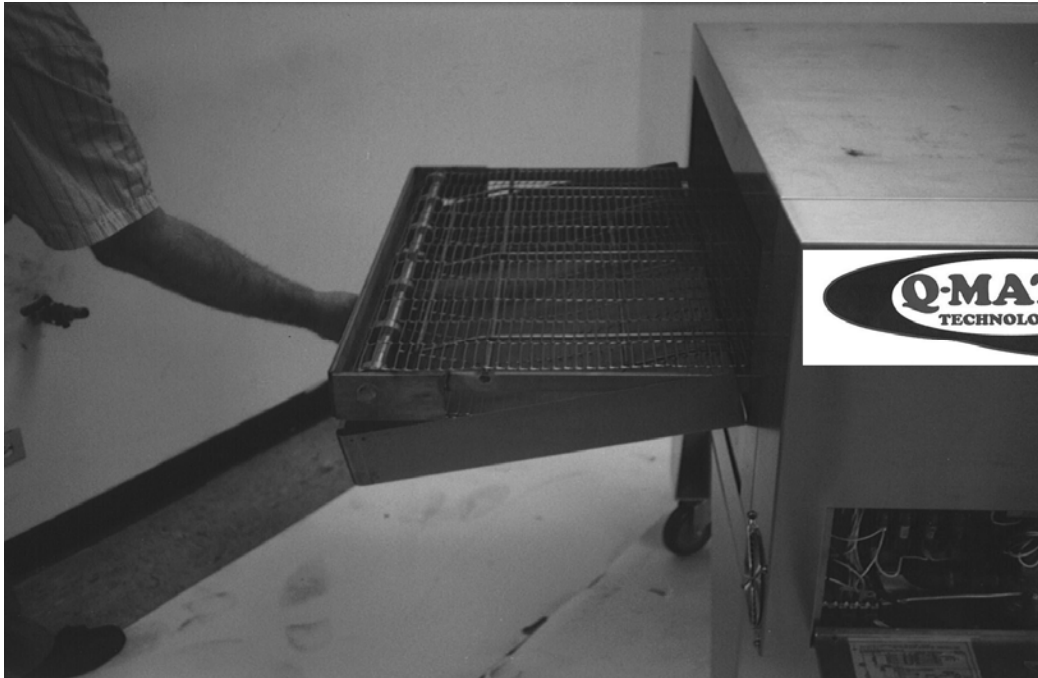

Figure 14

Install the left crumb pan. Refer to Figure 15

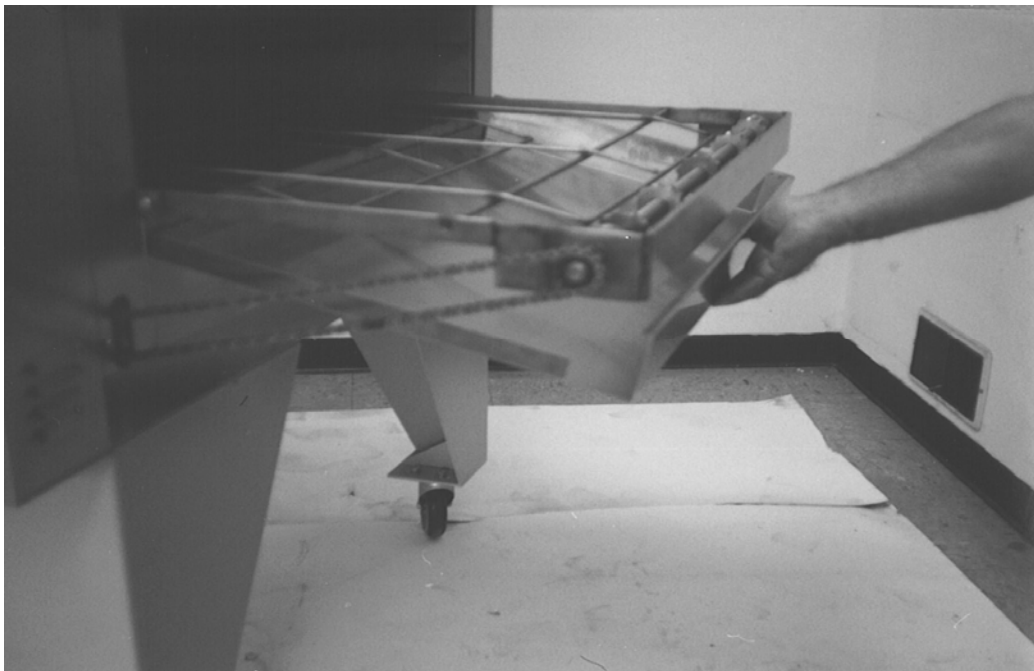

Figure 15

The oven is now ready to be rolled into place and connected to gas/power supplies for adjustment and start-up procedure.

# Gas Piping

## Gas Ratings

Q-Matic 36/36H – 90,000 BTU/hr

Q-Matic 36W/36WH – 120,000 BTU/hr

Q-Matic 55 – 160,000 BTU/hr

Q-Matic 80 – 240,000 BTU/hr

In order to achieve the degree of performance for which the oven was designed, a well planned and properly sized gas supply system is essential.

Necessary gas pressure before the oven's regulator must be a minimum of 4.5" W.C. for natural gas and 10.5" W.C. for LP gas. The installation must conform with local codes, or in the absence of local codes, with the National Fuel Gas Codes, NFPA 54-1980 and ANSI Z23. 1-1980.

Your plumbing contractor should consult the National Fuel Gas Code for proper sizing and installation of gas piping. Generally speaking, piping should be sized to provide a supply of gas efficient to meet the maximum demand of all the appliances on the line without undue loss of pressure at the equipment. Therefore, the total BTU/HR requirements of the equipment served and the length of piping from the meter to the appliances are major considerations in the proper design of the gas supply system. Piping of less than  $\frac{3}{4}$ " diameter is not recommended for natural gas installation. The oven is mounted on casters so flexible connectors should be of a braided stainless steel commercial duty type with

a minimum of  $\frac{3}{4}$ " diameter. The connector must comply with the Standard for Connectors for Movable Gas Appliances, ANZI Z21. 69-1979. A restraint must be placed on the unit to limit the movement of the oven so that no strain is placed on the flexible connector. The restraint (i.e. heavy gauge chain or cable) should be attached to the building so as to prevent damage to the building. **DO NOT** use the gas piping or electrical conduit for the attachment of the permanent end of the restraint! Use anchor bolts in concrete or cement block. On wooded walls, use high test wood lag screws into the studs of the wall. The opposite end of the restraint should be fastened to the appliance in such a way as to not damage the appliance or gas connector when the restraint is taut. It is recommended the restraint line to be attached to the base frame of the appliance.

Each oven has been adjusted at the factory to operate on the type of gas specified on the rating plate of the individual unit. This plate is located in the back of the oven above the gas and electrical connections. Each oven is supplied with a gas pressure regulator preset to provide 3.5" W.C. pressure for natural gas and 10.5" W.C. for L.P. gas. The regulator is located on the combination main and pilot valve.

**DO NOT INSTALL AN ADDITIONAL REGULATOR WHERE OVEN CONNECTS TO THE GAS SUPPLY.**

Prior to connecting the oven, gas line should be thoroughly purged of all metal filings, shavings, pipe dope and other debris. After connection, the oven should be checked for correct gas pressure. The correct gas pressure is 3.5" W.C. for natural gas and 10.5" W.C. for LP after the pressure regulator, when all main burners are on.

A drip leg must be installed at each appliance.

**MAXIMUM CAPACITY OF IRON PIPE IN CUBIC FEET OF NATURAL GAS PER HOUR.**

(Pressure drop of 0.5" W. C)

**MAXIMUM CAPACITY OF SEMI-RIGID TUBING IN THOUSAND OF BTU PER HOUR OF UNDILUTED LP GAS**

(At 11 inches W.C. Inlet Pressure)

Length of pipe per ft.	Nominal Size, Inches.				
	¾"	1"	1 ¼"	1 ½"	2"
10	360	680	1400	2100	3950
20	250	465	950	1460	2750
30	200	375	770	1180	2200
40	170	320	660	990	1900
50	151	285	580	900	1680
60	138	260	530	810	1520
70	125	240	490	750	1400
80	118	220	460	690	1300
90	110	205	430	650	1220
100	103	195	400	620	1150

Length of tubing per ft.	Outside Diameter, Inches.			
	1/2"	5/8"	3/4"	7/8"
10	92	199	329	501
20	62	131	216	346
30	50	107	181	277
40	41	90	145	233
50	37	79	131	198
60	35	72	121	187
70	31	67	112	164
80	29	62	104	155
90	27	59	95	146
100	26	55	90	138

## Gas Pipe Sizing

Oven Size	BTU/H	10ft.	20ft.	30ft.	40ft.	50ft.	60ft.	70ft.	80ft.	90ft.	100ft.	110ft.	120ft.	130ft.	140ft.	150ft.	160ft.	170ft.	180ft.	190ft.	200ft.
Q-36	90,000	1/2"	1/2"	1/2"	3/4"	3/4"	3/4"	3/4"	3/4"	3/4"	3/4"	3/4"	3/4"	1"	1"	1"	1"	1"	1"	1"	1"
Q-36W	120,000	1/2"	3/4"	3/4"	3/4"	3/4"	3/4"	3/4"	1"	1"	1"	1"	1"	1"	1"	1"	1"	1"	1"	1"	1"
Q-55	160,000	3/4"	3/4"	3/4"	3/4"	1"	1"	1"	1"	1"	1"	1"	1"	1 1/4"	1 1/4"	1 1/4"	1 1/4"	1 1/4"	1 1/4"	1 1/4"	1 1/4"
Q-36 double	180,000	3/4"	3/4"	3/4"	1"	1"	1"	1"	1"	1"	1"	1"	1"	1 1/4"	1 1/4"	1 1/4"	1 1/4"	1 1/4"	1 1/4"	1 1/4"	1 1/4"
Q-36W double	240,000	3/4"	3/4"	1"	1"	1"	1"	1 1/4"	1 1/4"	1 1/4"	1 1/4"	1 1/4"	1 1/4"	1 1/4"	1 1/4"	1 1/4"	1 1/4"	1 1/4"	1 1/4"	1 1/4"	1 1/4"
Q-80	240,000	3/4"	3/4"	1"	1"	1"	1"	1 1/4"	1 1/4"	1 1/4"	1 1/4"	1 1/4"	1 1/4"	1 1/4"	1 1/4"	1 1/4"	1 1/4"	1 1/4"	1 1/4"	1 1/4"	1 1/4"
Q-36 triple	270,000	3/4"	1"	1"	1"	1 1/4"	1 1/4"	1 1/4"	1 1/4"	1 1/4"	1 1/4"	1 1/4"	1 1/4"	1 1/4"	1 1/4"	1 1/4"	1 1/4"	1 1/4"	1 1/4"	1 1/4"	1 1/4"
Q-55 double	320,000	3/4"	1"	1"	1"	1 1/4"	1 1/4"	1 1/4"	1 1/4"	1 1/4"	1 1/4"	1 1/4"	1 1/4"	1 1/4"	1 1/4"	1 1/4"	1 1/4"	1 1/4"	1 1/4"	1 1/4"	1 1/4"
Q-36W triple	360,000	3/4"	1"	1"	1 1/4"	1 1/4"	1 1/4"	1 1/4"	1 1/4"	1 1/4"	1 1/4"	1 1/4"	1 1/4"	1 1/4"	1 1/2"	1 1/2"	1 1/2"	1 1/2"	1 1/2"	1 1/2"	1 1/2"
Q-55 triple	480,000	1"	1 1/4"	1 1/4"	1 1/4"	1 1/4"	1 1/4"	1 1/4"	1 1/2"	1 1/2"	1 1/2"	1 1/2"	1 1/2"	1 1/2"	1 1/2"	2"	2"	2"	2"	2"	2"
Q-80 double	480,000	1"	1 1/4"	1 1/4"	1 1/4"	1 1/4"	1 1/4"	1 1/4"	1 1/2"	1 1/2"	1 1/2"	1 1/2"	1 1/2"	1 1/2"	1 1/2"	2"	2"	2"	2"	2"	2"
Q-80 triple	720,000	1 1/4"	1 1/4"	1 1/4"	1 1/2"	1 1/2"	1 1/2"	1 1/2"	2"	2"	2"	2"	2"	2"	2"	2"	2"	2"	2"	2"	2"

Minimum Gas Line Sizing (in inches)

	10	20	30	40	50	60	70	80	90	100	125	150	175	200
1/2"	174	119	96	82	73	66	61	56	53	50	44	40	37	34
3/4"	363	249	200	171	152	138	127	118	111	104	93	84	78	72
1"	684	470	377	323	286	259	239	222	208	197	174	158	146	135
1 1/4"	1404	965	775	663	588	532	490	456	428	404	358	324	301	278
1 1/2"	2103	1445	1161	993	880	798	734	683	641	605	536	486	451	416
2"	4050	2784	2235	1913	1696	1536	1413	1315	1234	1165	1033	936	868	801
2 1/2"	6455	4437	3563	3049	2703	2449	2253	2096	1966	1857	1646	1492	1384	1277
3"	11412	7843	6299	5391	4778	4329	3983	3705	3476	3284	2910	2637	2447	2257

Maximum capacity in CFH

	10	20	30	40	50	60	70	80	90	100	125	150	175	200
1/2"	174000	119000	96000	82000	73000	66000	61000	56000	53000	50000	44000	40000	37000	34000
3/4"	363000	249000	200000	171000	152000	138000	127000	118000	111000	104000	93000	84000	78000	72000
1"	684000	470000	377000	323000	286000	259000	239000	222000	208000	197000	174000	158000	146000	135000
1 1/4"	1404000	965000	775000	663000	588000	532000	490000	456000	428000	404000	358000	324000	301000	278000
1 1/2"	2103000	1445000	1161000	993000	880000	798000	734000	683000	641000	605000	536000	486000	451000	416000
2"	4050000	2784000	2235000	1913000	1696000	1536000	1413000	1315000	1234000	1165000	1033000	936000	868000	801000
2 1/2"	6455000	4437000	3563000	3049000	2703000	2449000	2253000	2096000	1966000	1857000	1646000	1492000	1384000	1277000
3"	11412000	7843000	6299000	5391000	4778000	4329000	3983000	3705000	3476000	3284000	2910000	2637000	2447000	2257000

Maximum capacity in BTU/H

# Electrical Connections

Before making any electrical connections to these units, check that power supply is adequate for the voltage, amperage and phase requirements stated on the rating name plate mounted in the back of the oven above the gas and electrical connections.

All ovens, when installed must be electrically grounded in accordance with local codes. In absence of local codes, with the National electric code.

Schematic wiring diagrams are located in the back of this manual. All standard Q-Matic models are equipped for operation on 120/208-230 VAC, 1 phase, 50-60hz., 3 wires, grounded circuits. Wiring from the power source to these units should conform with electrical codes.

## **CAUTION!!!**

**All units must NOT be connected to the “High” phase of a three (3) phase system. “High” phase refers to potential of 208 volts between one “leg” and neutral. The remaining two “legs” will have the potential of 115 volts between each phase and neutral. Failure to do so will result in extensive damage to the electrical components and possible fire in the control panel.**

Q-Matic Technologies cannot assume responsibility for loss or damage suffered as a result of improperly installed units.

Connection of the Q-Matic ovens involves three (3) wires at the connection box located at the left side in the back (refer to component location). Two wires are #8 OR #10 gauge, and are to be connected to the 208-230 Volt power source. One wire is #18 gauge and is to be connected to the system neutral.

**The oven should be grounded at the connection box.**

# Component Locations

Section 1

Section 2

Section 3

Section 4

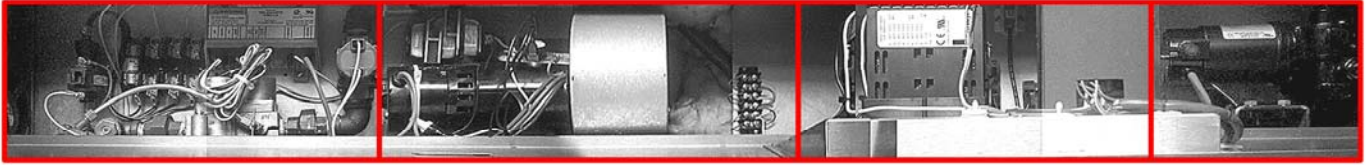

See next page for details

Section 1

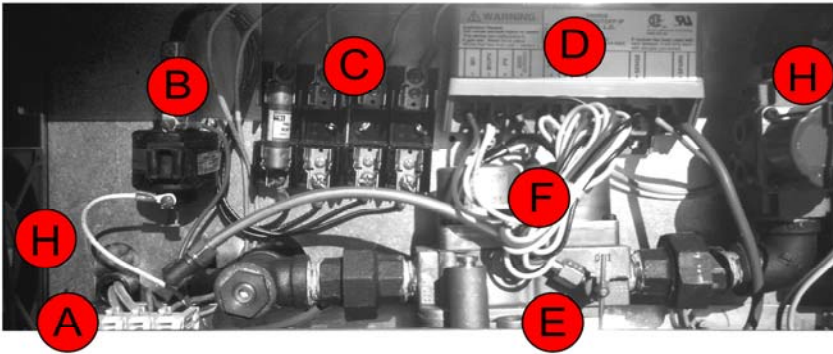

- A – Terminal Block
- B – Mercury Relay
- C – Fuse Holders (fuses for top elec. elements)
- D – Ignition Module
- E – Pilot Adjustment Valve
- F – Main Valve
- G – Solenoid Valve (bottom gas heaters)
- H – Cooling Fan

Section 2

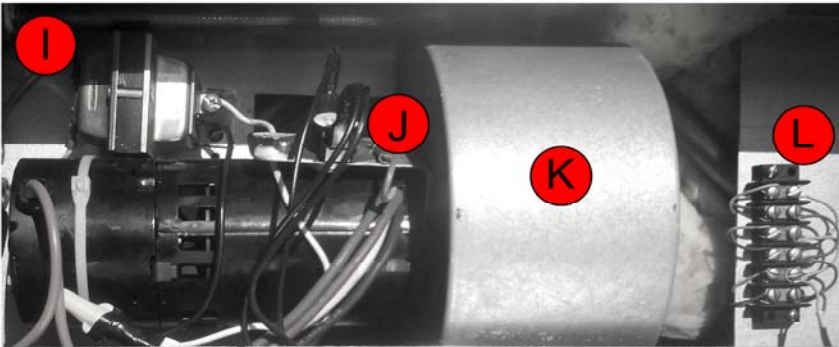

- I – 24v Ignition Transformer
- J – Snap Disc Cooling Fan Thermostat
- K – Combustion Blower
- L – Thermocouple Block

Section 4

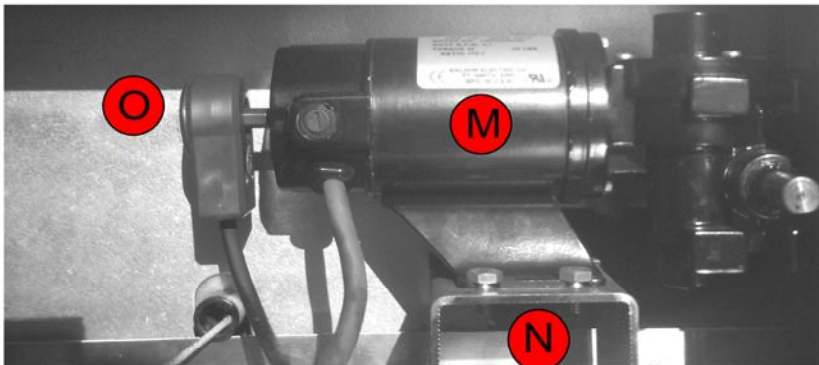

- M – Conveyor Drive Motor
- N – Conveyor Mounting Bracket
- O – Conveyor Motor Pick-Up

# Control Panel

## Front View

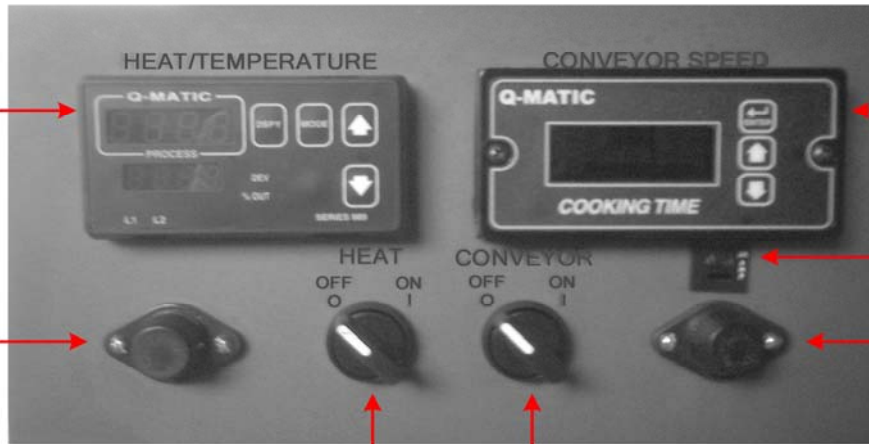

Temperature Control

Conveyor Speed Control

Heat Circuit Fuse

Circuit Breaker

Conveyor Circuit Fuse

Heat "On/Off" Switch

Conveyor "On/Off" Switch

Heat Circuit Fuse

Conveyor Circuit Fuse

Temperature Control

Circuit Breaker

Conveyor Speed Control

## Back View

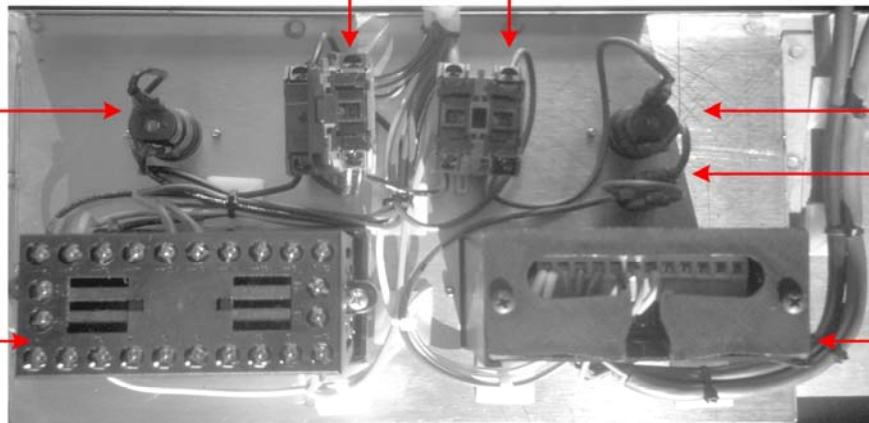

Heat Circuit Fuse

Conveyor Circuit Fuse

Temperature Control

Circuit Breaker

Conveyor Speed Control

# Oven Start-up

- Turn “heat” switch on.
- Turn Conveyor switch on.
  - The following will occur:
    - The spark ignition will go on and light the pilot located inside of the oven parallel with the back wall. Check that the pilot flame is extended the entire length of the pilot. The spark igniter will produce a spark for 20 seconds and if the pilot flame is not established within 20 seconds the ignition control will lock-out. To reset the ignition, turn off both switches, wait for 5 seconds and turn again both switches on.

Note: At the initial start-up, the air has to be purged from the gas line, therefore a few trials may be necessary to light the pilot. If necessary the gas flow to the pilot can be adjusted with the pilot adjustment valve located on the inside of the control panel on the pilot line.
    - After the flame sensor is satisfied, the main valve opens and the temperature controller will start cycling on/off the gas valve for bottom heaters and the mercury relay for top heaters.
- Temperature Controller
  - Default settings
    - Temperature set point – 550°F
    - Bottom heat time on (ton1) - 15 seconds
    - Bottom heat time off (toF1) – 20seconds
    - Bottom heat HSC (HSC1) - 4°F
    - Bottom heat interval (int1) – 3 seconds
    - Top heat time on (ton2) – 25 seconds
    - Top heat time off (toF2) – 15 seconds
    - Top heat HSC (HSC2) – 4°F
    - Top heat interval (int2) – 9 seconds

## Note:

For proper performance, BOTH heat and conveyor switches should be on at all times.

# Using The Temperature Control - Temperature Control Button Layout

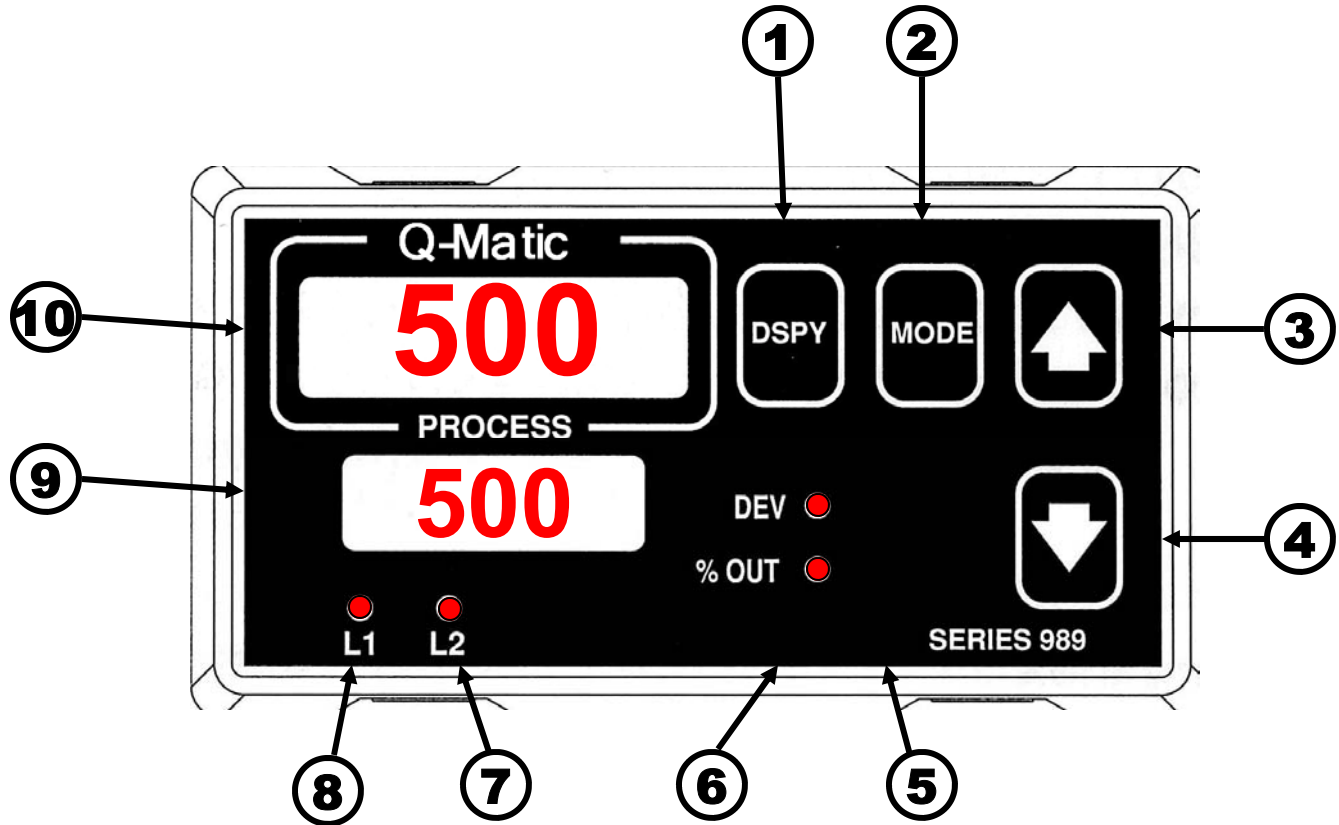

- 1) Display Button
- 2) Mode Button
- 3) Up Arrow
- 4) Down Arrow
- 5) Deviation LED
- 6) Percentage Output LED
- 7) L2 (Top Heat) LED
- 8) L1 (Bottom Heat) LED
- 9) Lower Display
- 10) Upper Display

# Using The Temperature Control - On oven start-up

Upon turning the oven on, the following will happen:

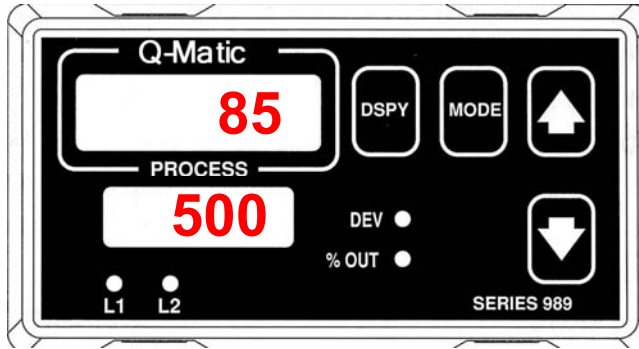

1) When the oven is turned on the control displays the set point in the lower display and the actual temperature in the upper display. After a period of about one minute the controller will begin cycling the top heaters and bottom burners on and off. The controller will continually cycle the top and bottom heat on and off while the power is on to the controller.

After about one minute, the following will happen:

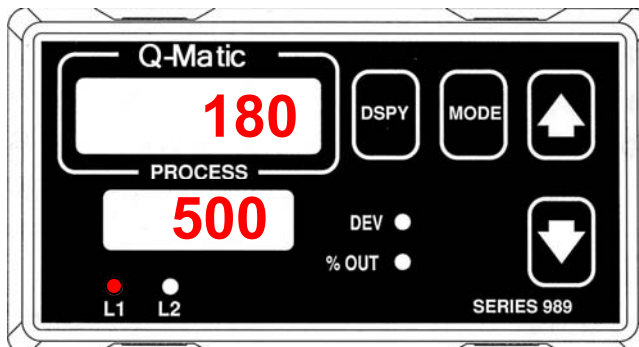

2) As the control cycles the heat on and off you will notice that in the lower left hand corner the L1 & L2 LED lights will go on and off. These LED lights will come on to let you know when the heating elements are cycling on. The actual temperature (upper display) will begin to rise. The gas burners at the bottom are more powerful than the top electric elements therefore about 90% of the heating and cooking is achieved through the gas burners. The top electric elements will help to melt the cheese and give desired color to the top of the pizza.

After about 15-20 minutes the following will happen:

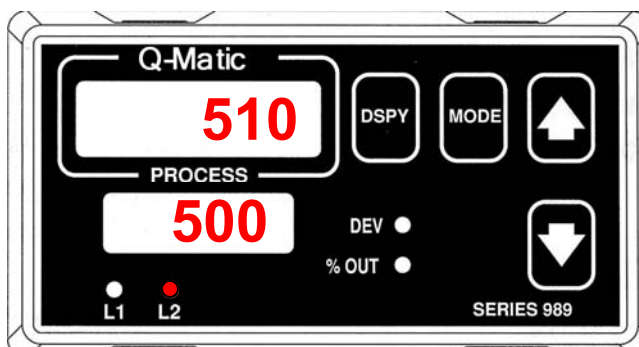

3) At some point (usually about 15 minutes) the oven will reach operating temperature. It is normal for the temperature to vary a bit from the set point. The specifics of how much it should vary is covered elsewhere in this manual but generally it is no more than about 15 degrees above or below the set point (lower display)

# Using The Temperature Control - Changing the temperature

To change the temperature set point:

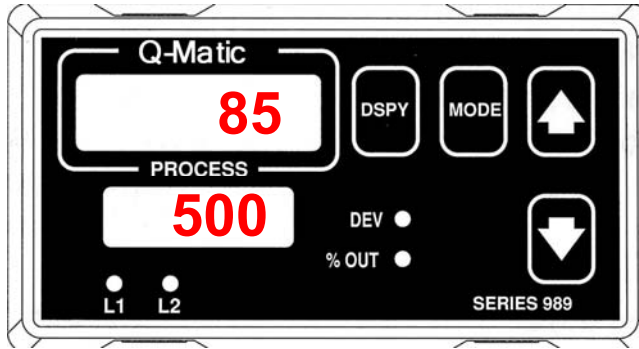

1) Changing the oven set point is achieved by simply pushing the up (increase) or down (decrease) arrows to change from the present setting.

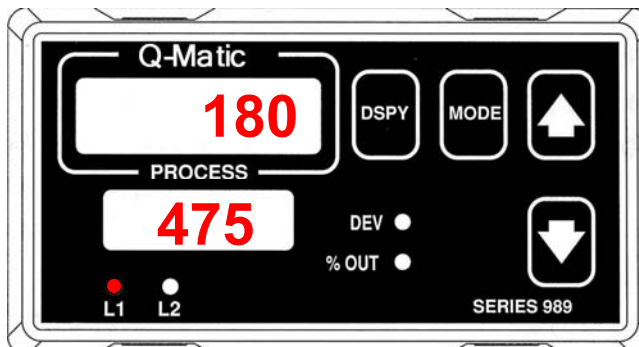

2) Once the temperature is changed the new temperature will appear each time the oven is turned on.

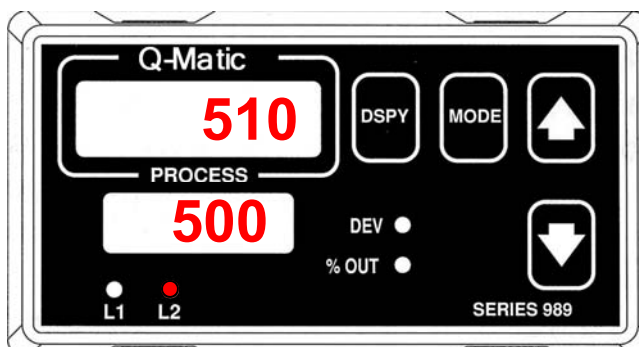

3) The temperature set point can be changed at any time. However the set point is only going to go as high as the on and off cycles of the heating elements. The next pages will explain how this works and how to adjust them.

# **Using The Temperature Control - Adjusting the temperature**

The oven's set point is directly affected by the on and off settings of the burners and heaters. This is especially true of the bottom burners which make up 85%+ of the heat in the oven. Having the ratio of on and off cycle is critical to the product cooking properly.

For example, if the set point is set to 450 degrees the on cycle should be set to a range of 12.0 to 14.0 seconds. The off cycle should be in the 20.0 to 24.0 second range. These settings have the proper ratio of on to off cycle to maintain this temperature.

If then cycle on for too long or not off long enough the temperature can soar above the set point and the oven will not cook properly. This can cause the product to suddenly begin to under cook. Since the temperature set point is limited it will go reach the setpoint plus the amount it is allowed to go over as dictated by the HSC1 then the controller will skip the on cycle until the temp is brought below this threshold and continue repeating this sequence over and over. The effect on the product traveling through the oven is that even though the oven is showing that the temperature is well over the set point since the burners are not cycling on as often the product will look undercooked. The reason for this is that the product is cooked with the infrared energy it receives and not with the ambient temperature inside the oven.

If the on cycle is too low or the off cycle is too high the oven will constantly struggle to reach or maintain the set point. The controller will also shorten the off cycle as dictated by the INT1 to try to raise the temperature up to the set point. If the oven struggles to maintain the set point when empty or idling then when product is run through the oven the temperature may drop even more. The effect on the product traveling through the oven will probably be overcooking especially on the bottom. The reason for this is that even though the display is showing that the oven is under temperature is below the set point since the controller is shortening the off cycle the product is receiving too much infrared and the product will overcook or burn the bottom.

The condition of the burners will also play a major role in the ovens ability to maintain proper temperature and cook consistently. If the setting for the product is made when the oven is new or thoroughly cleaned and is working at 100% efficiency. If then it over a period of time it begins to give inconsistent results then the problem most likely is that the burners have become covered with ash deposits and are no longer heating at 100%. The solution is to start a routine to clean the oven at regular intervals. This is known as preventative maintenance and will go a long way not only keep the oven cooking consistently but also extend the life of parts. The other benefits are lower repair costs and maintaining its energy efficiency.

# **Using The Temperature Control - Summary**

**The temperature controller used in this oven is a very sophisticated and precision instrument that is a large part of the ovens capability to give the results the oven is capable of and maintain these results consistently. It is infinitely adjustable and can be fine tuned to give the exact results that you desire. Initially it can take a number of adjustments to “dial it in” but once this is done nothing else will need to be done, except turning it on at the beginning of the day and off at the end of the day. All the adjustments necessary over the course of the day with different volumes of product is handled by the controller. The only thing required by the operator is basic maintenance and putting consistent products into the oven. If these requirements are met then this oven will provide years of trouble free service.**

# Using The Temperature Control - Adjusting the HSC1 (bottom burners)

To adjust the HSC1 follow the steps below:

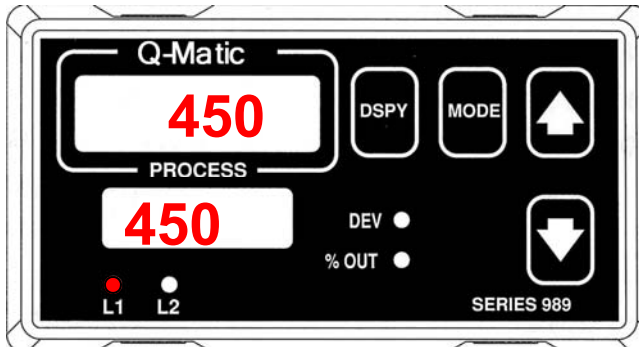

From the default screen begin by pressing the UP & DOWN arrow together at the same time until the display changes then let both buttons go.

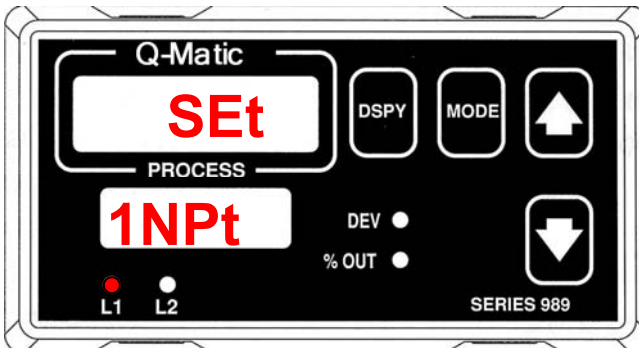

The display will show INPT on the bottom display and SET in the top display.

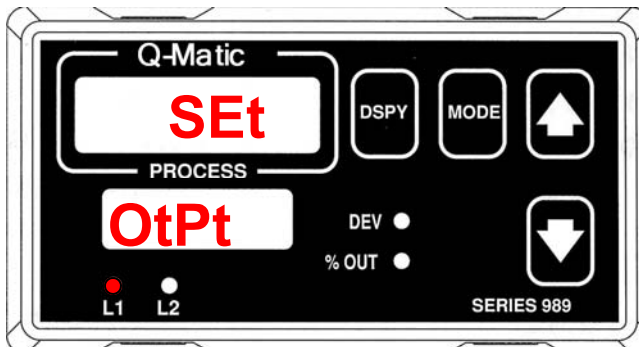

Press the UP arrow until the display reads OTPT in the bottom display & SET in the top display.

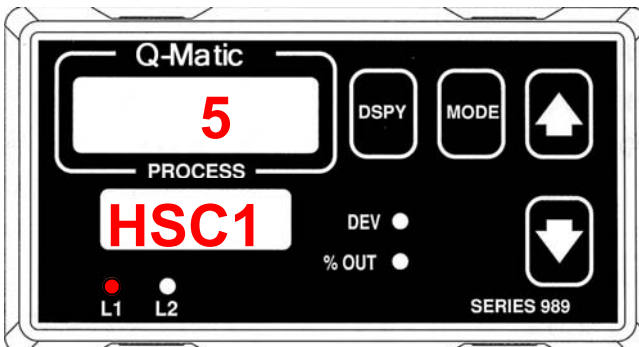

Press the UP arrow twice and the bottom display will read HSC1 and the top display will display a number. To change the value press the up arrow to increase or down to decrease.

# Using The Temperature Control - Adjusting the HSC2 (top heaters)

To adjust the HSC2 follow the steps below:

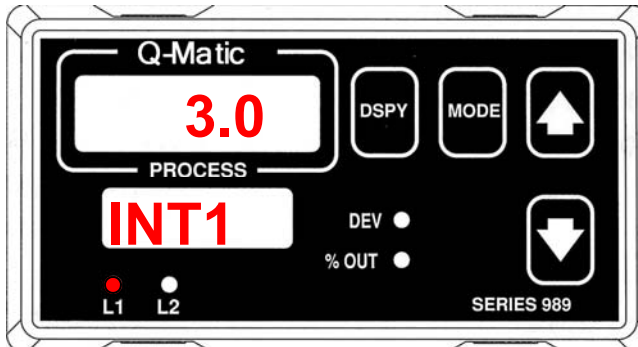

From INT1 press the mode button Twice.

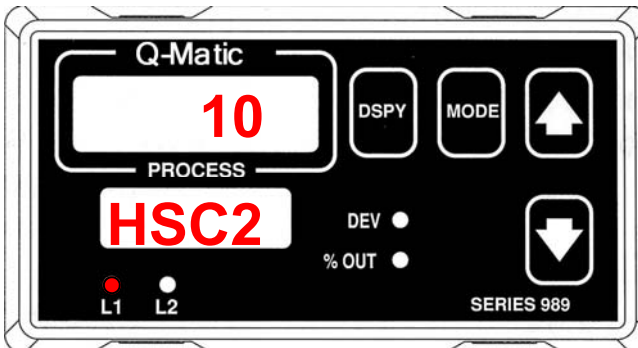

The display will show HSC2 on the bottom display and a number value in the top display.

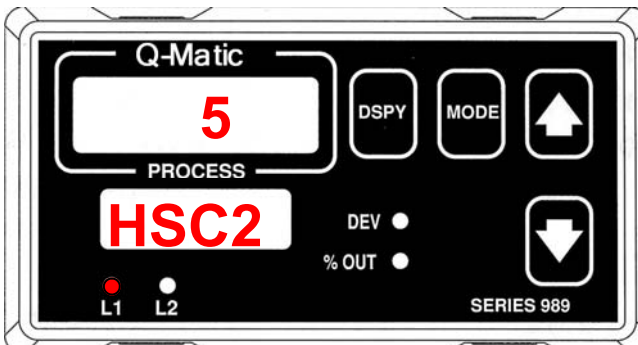

Press the UP arrow to change the value. Press the up arrow to increase or down to decrease.

# Using The Temperature Control - Adjusting the oven to maintain consistency under load

In order for the oven to maintain a consistent bake whether baking one or ten pizzas it must be adjusted to react when under load. This is done by two settings in the controller. The first is the HSC and the second is the INT.

The HSC is used to specify how many degrees the temperature will be allowed vary from the set point. It is adjustable from 1 to 10 and each of the 10 steps has a value of 4 degrees. In other words an HSC value of 1 to 10 equals 4 to 40 degrees. This is the maximum number of degrees it will be allowed to vary. The control will continually make adjustments in order to maintain set point. Below are some examples of how it works:

<i>Set Point</i>	<i>HSC</i>	<i>Min temp</i>	<i>Max Temp</i>
500 degrees	1 (4 degrees)	496 degrees	504 degrees
500 degrees	2 (8 degrees)	492 degrees	508 degrees
500 degrees	3 (12 degrees)	488 degrees	512 degrees
500 degrees	4 (16 degrees)	484 degrees	516 degrees
500 degrees	5 (20 degrees)	480 degrees	520 degrees
500 degrees	6 (24 degrees)	476 degrees	524 degrees
500 degrees	7 (28 degrees)	472 degrees	528 degrees
500 degrees	8 (32 degrees)	468 degrees	532 degrees
500 degrees	8 (36 degrees)	464 degrees	536 degrees
500 degrees	10 (40 degrees)	460 degrees	540 degrees

The INT is used to specify how much of an adjustment it will make in order to maintain the set point. This is done by shortening or lengthening the OFF cycle in order to maintain temp. The INT is adjustable from 1 to 20 in tenth of a second increments. This number much like the HSC is the maximum it will change the off cycle and it will make lesser adjustments up to the maximum. If the temperature goes above the maximum HSC it will skip the on cycle until it the temperature drops below the maximum HSC. Below are some examples of how it works:

### If above set Point-

<i>Set Point</i>	<i>Actual Temp</i>	<i>HSC</i>	<i>INT</i>	<i>Tofl</i>	<i>Adjusted</i>
500 degrees	521 degrees	5 (20 degrees)	2.0	skips on cycle	
500 degrees	520 degrees	5 (20 degrees)	2.0	20 seconds	22.0 seconds
500 degrees	515 degrees	5 (20 degrees)	2.0	20 seconds	21.5 seconds
500 degrees	510 degrees	5 (20 degrees)	2.0	20 seconds	21.0 seconds
500 degrees	505 degrees	5 (20 degrees)	2.0	20 seconds	20.5 seconds
500 degrees	500 degrees	5 (20 degrees)	2.0	20 seconds	20.0 seconds

*Continued on next page*

## Using The Temperature Control - Adjusting the oven to maintain consistency under load – continued

If below Set Point-

<i>Set Point</i>	<i>Actual Temp</i>	<i>HSC</i>	<i>INT</i>	<i>Tofl</i>	<i>Adjusted</i>
500 degrees	480 degrees	5 (20 degrees)	2.0	20 seconds	18.0 seconds
500 degrees	485 degrees	5 (20 degrees)	2.0	20 seconds	18.5 seconds
500 degrees	490 degrees	5 (20 degrees)	2.0	20 seconds	19.0 seconds
500 degrees	495 degrees	5 (20 degrees)	2.0	20 seconds	19.5 seconds
500 degrees	500 degrees	5 (20 degrees)	2.0	20 seconds	20.0 seconds

The above are just some examples of setting and how they help to maintain consistency. With the range of adjustment available the both the HSC & INT the oven has the capability of being fine tuned to react and maintain consistency regardless of the product or the amount of product being cooked.

# Using The Temperature Control - Adjusting the INT1 (bottom burners)

To adjust the INT1 follow the steps below:

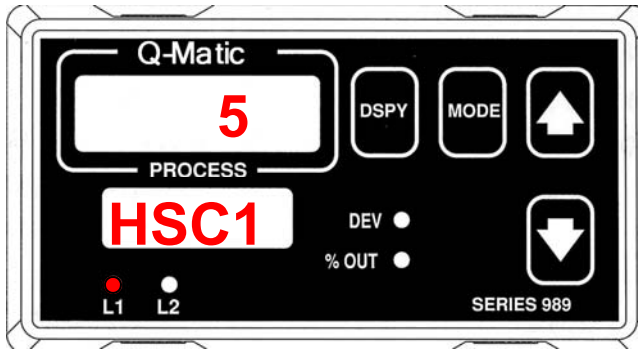

From HSC1 press the mode button one time.

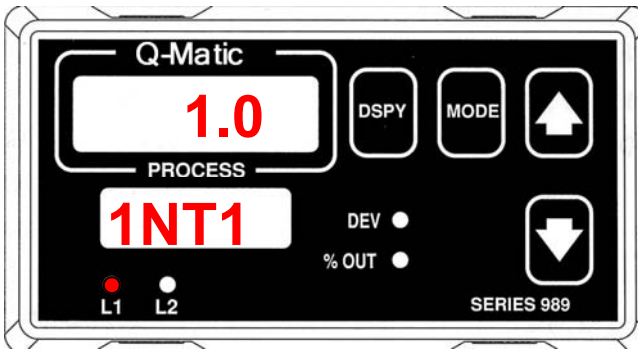

The display will show INPT on the bottom display and a number value in the top display.

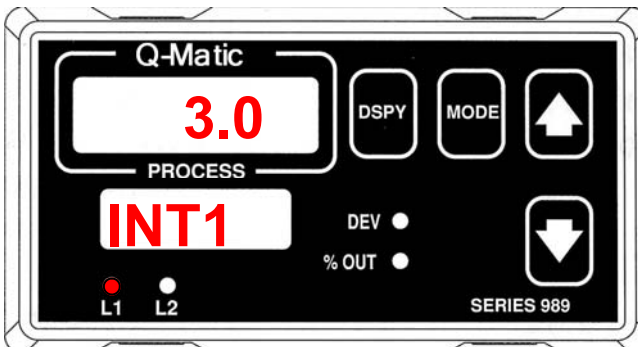

Press the UP arrow to change the value. Press the up arrow to increase or down to decrease.

# Using The Temperature Control - Adjusting the INT2 (bottom burners)

To adjust the INT2 follow the steps below:

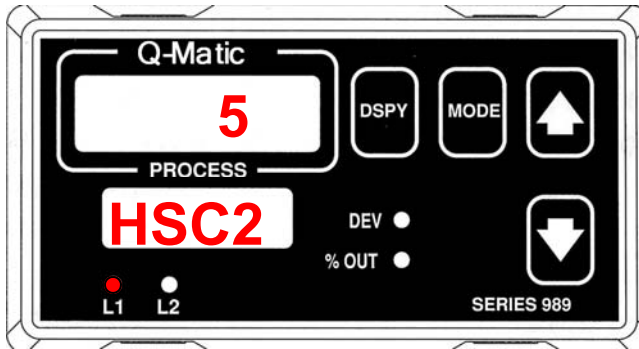

From HSC1 press the mode button one time.

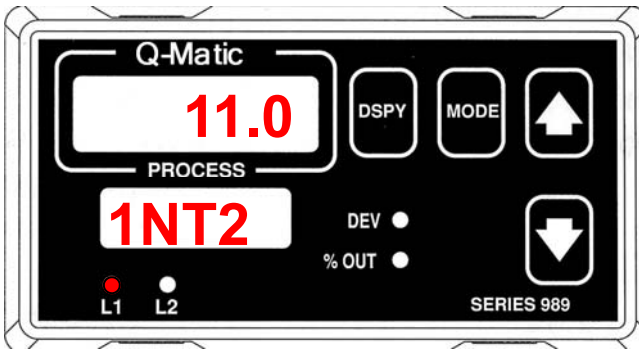

The display will show INT2 on the bottom display and a number value in the top display.

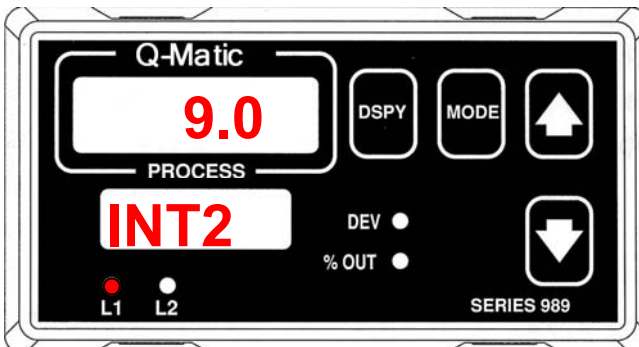

Press the UP arrow to change the value. Press the up arrow to increase or down to decrease.

# Using The Temperature Control - Changing the OFF setting for the bottom burners

To change the off cycle:

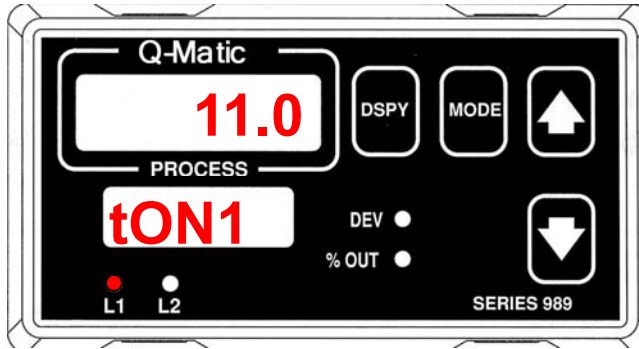

1) Push the mode button

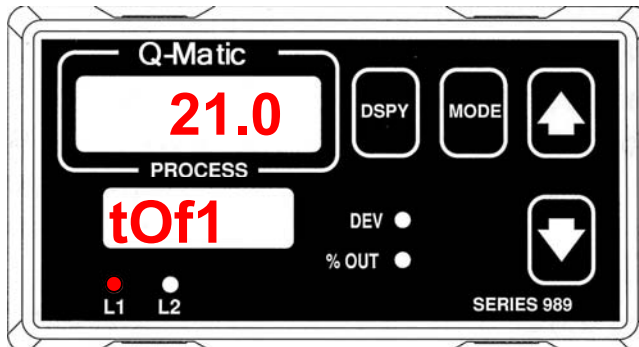

2) When you push the mode button once the bottom display will show TOF1 or Time OFF 1. This is how long the burners will go off for.

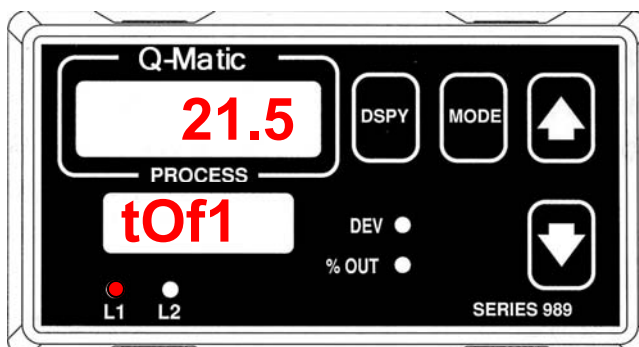

3) The TOF1 can be changed by pressing either the up to increase or down to decrease. The number displayed in the upper display is how long the burner will go off for. This is adjustable in tenth of a second increments and the larger the number the longer the burners will stay off for. When adjusting the burners it is advised that you make adjustment half a second at a time. The burners are 30,000 to 40,000 BTU's each and a small adjustment can make a BIG difference when it is spread out over the time the product travels through the oven.

# Using The Temperature Control - Changing the OFF setting for the top electric elements

To change the off cycle:

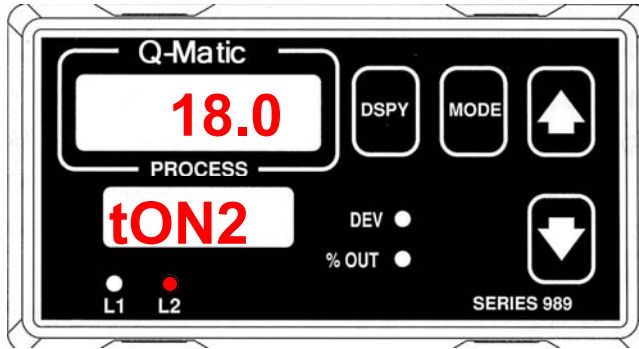

1) Push the mode button

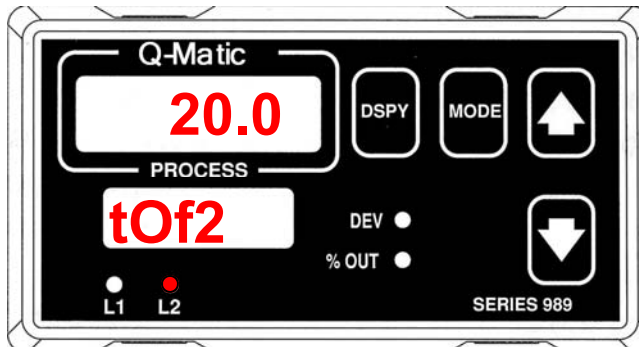

2) When you push the mode button once the bottom display will show TOF2 or Time OFF 2. This is how long the top elements will go off for.

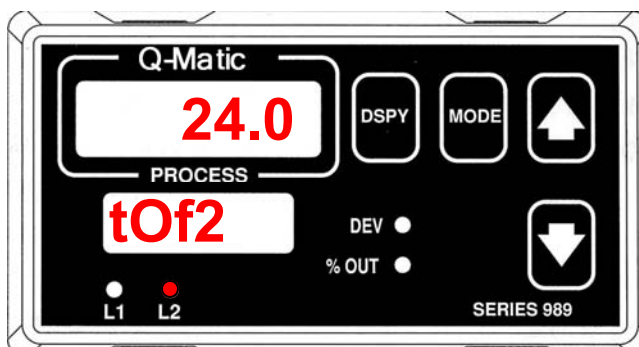

3) The TOF2 can be changed by pressing either the up to increase or down to decrease. The number displayed in the upper display is how long the electric element will go on for. This is adjustable in tenth of a second increments and the larger the number the longer the electric elements will stay on for. When adjusting the element it can be changed in 3-5 second increments at a time. Since the elements are electric they do not react as immediate as the bottom gas burners.

# Using The Temperature Control - Changing the ON setting for the bottom burners

To change the on cycle:

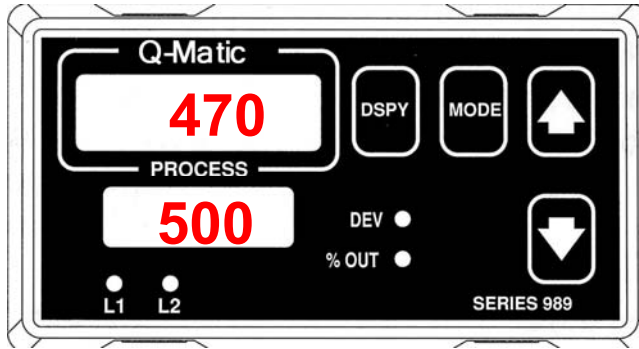

1) Push the mode button

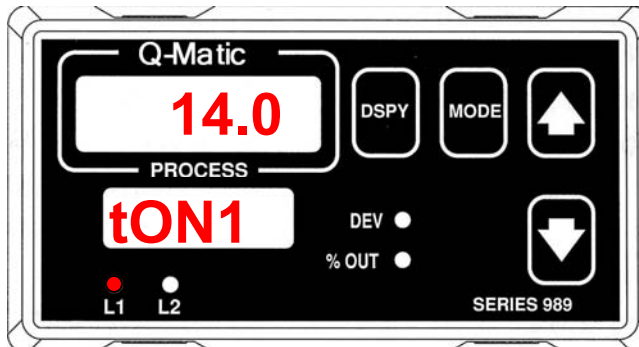

2) When you push the mode button once the bottom display will show TON1 or Time ON 1. This is how long the burners will go on for.

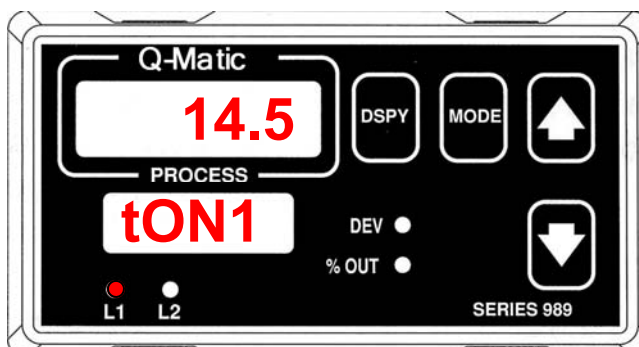

3) The TON1 can be changed by pressing either the up to increase or down to decrease. The number displayed in the upper display is how long the burner will go on for. This is adjustable in tenth of a second increments and the larger the number the longer the burners will stay on for. When adjusting the burners it is advised that you make adjustment half a second at a time. The burners are 30,000 to 40,000 BTU's each and a small adjustment can make a BIG difference when it is spread out over the time the product travels through the oven.

# Using The Temperature Control - Changing the ON setting for the top electric elements

To change the on cycle:

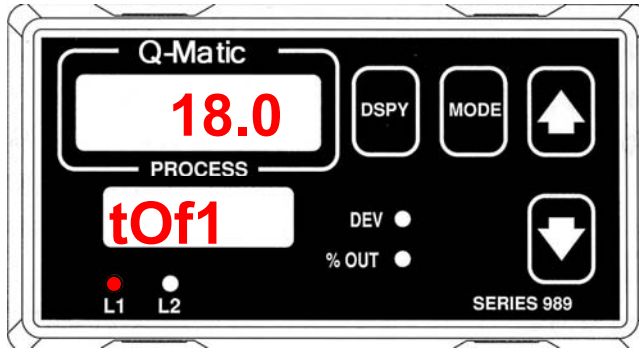

1) Push the mode button

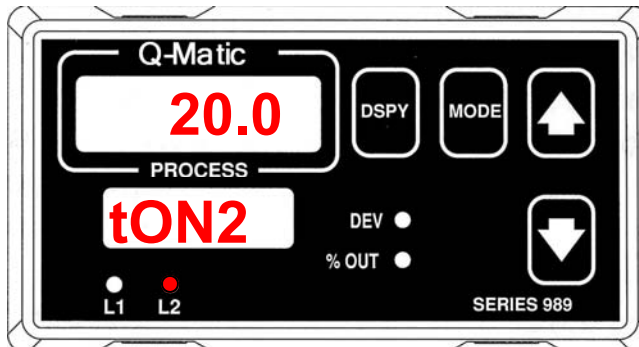

2) When you push the mode button once the bottom display will show TON2 or Time ON 2. This is how long the top elements will go on for.

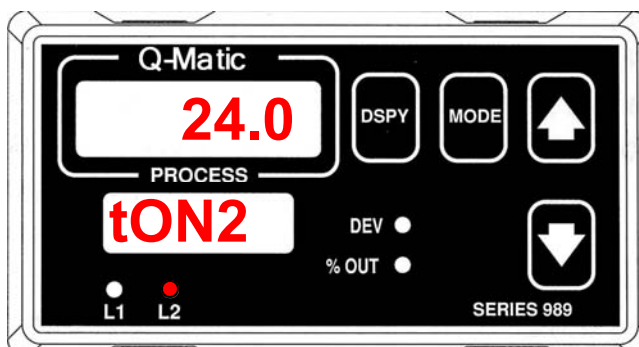

3) The TON2 can be changed by pressing either the up to increase or down to decrease. The number displayed in the upper display is how long the electric element will go on for. This is adjustable in tenth of a second increments and the larger the number the longer the electric elements will stay on for. When adjusting the element it can be changed in 3-5 second increments at a time. Since the elements are electric they do not react as immediate as the bottom gas burners.

# Oven Shut Down

- Turn the two switches to the OFF position.
- All Q-Matic ovens are equipped with a fan control snap disc thermostat that will start the cooling fan(s) when the temperature in the control box reaches 120°F, regardless if the oven is in operation or not. The cooling fan will shut off by itself when the temperature in the control box falls below 110°F.

## **WARNING!!!**

In the event of a power failure, all switches should be turned off and no attempt should be made to operate the appliance until power has been restored.

If a gas oven is to be turned off for an extended period of time, the gas supply to the unit should be turned off.

# Guidelines to adjusting Q-Matic ovens

There are an infinite of variety of pizzas out there and a Q-Matic oven has the means to adjust for each of them.

If you are already using any kind of oven, it is very important to answer some questions about how you are cooking your product.

A. If you are using deck ovens the question is to be asked is:

How long does it take to cook a pizza during light sales?

Ex.: If it takes 10 minutes in the periods that you are not that busy, it can be approximate that you will need 8-9 minutes in Q-Matic ovens.

A recommended starting set-up will be like the following:

- Temperature set: 450°F
- Cooking time set: 9 minutes
- ton1: 15 seconds; toF1: 20 seconds
- Top heaters set-up 1 & 3 (only fuses 1 & 3 in the control panel should be plugged in.
- ton2: 25 seconds; toF2: 15 seconds
- Top end plug in closed position at the entry side, open at the exit side.

B. If you are using other conveyor ovens, i.e.; Middleby Marshall, Lincoln Impinger or Mastertherm is also important to find out about the cooking time and cooking temperature.

Ex.: If it takes 7 minutes to cook in the above conveyor ovens at 480°F the previous set-up is still applicable by changing the cooking time to 8 minutes.

The following are recommended set-ups for different style pizzas;

1. For thin crust pizza that needs a great concentration of heat in a short period of time, starting set-up should be:
  - Temperature set: 500°F
  - Cooking time set: 6 minutes
  - ton1: 16.5 seconds; toF1: 20 seconds
  - Top heaters set-up 1,2 & 3 (the fourth fuse should be out of the fuse holder)
  - ton2: 25 seconds; toF2: 15 seconds
  - Top end plug in closed position at the entry side, open at the exit side
  
2. For thick crust pizza that will need more time in the oven for developing the dough and cook through, a starting set-up should be:
  - Temperature set: 430°F
  - Cooking time set: 11 minutes
  - ton1: 13 seconds; toF1: 20 seconds
  - Top heaters set-up 1 & 3 (only fuses 1 & 3 should be plugged in)
  - ton2: 20 seconds; toF2: 25 seconds
  - Top end plug in closed position at the entry side, open at the exit side
  
3. For pan pizza a starting set-up should be:
  - Temperature set: 410°F
  - Cooking time set: 14 minutes
  - ton1: 11 seconds; toF1: 26 seconds
  - Top heaters set-up 1 & 3 (Only fuses 1 & 3 should be plugged in)
  - ton2: 20 seconds; toF2: 30 seconds
  - Top end plug in closed position at the entry side, open at the exit side
  
4. For stuffed pizza a starting set-up should be:
  - Temperature set: 380°F
  - Cooking time set: 20 minutes
  - ton1: 9.5 seconds; toF1: 30 seconds
  - Top heaters set-up 1 (Only the first fuse should be plugged in)
  - ton2: 20 seconds; toF2: 20 seconds
  - Top end plugs open at both ends

The following recommended start-up settings are just that, a starting point and several adjustments may follow to obtain the right one for any given product.

For each test done, the use of the Product Testing Form (located at the back of this manual) will be a helpful tool. The testing form will help keep track of the results for each test and will give a prospective view of the accomplishment after each adjustment.

Q-Matic has an infinite number of adjustments and has been designed to accommodate any kind of pizza it may encounter. It is important to limit the number of changes for each test so it can be understood which change had the desired effect. The effect of the change cannot be recognized immediately. The full impact of a change can be seen only in a pizza that is cooked through the cycle after the change was made.

What are we looking for when judging the results of a test?

1. Pleasant appearance and nice color for top and bottom.
2. Good internal temperature;
  - 190°F to 210°F for a cheese or cheese and pepperoni pizza.
  - 165°F to 175°F for a pizza with multiple vegetable toppings.
3. A well cooked dough:
  - A well cooked dough is risen up to the wet line that separates the sauce from the dough
  - A well cooked dough is strong, holding the toppings and doesn't collapse when held up.
  - A well cooked dough separates when cut.
  - A well cooked dough has a crunchy layer on the bottom

**A well cooked dough is what a good pizza is made of!!!**

Let us suppose that we have used the starting set-up #1 and the comments after judging the pizza are the following:

1. The pizza is too dark top and bottom.
2. Internal temperature is good, with the above limits.
3. The dough is not cooked up to the moisture and is floppy.

The above characteristics are for a pizza that was cooked too fast in too much heat. That particular dough will need more time to develop at a lower temperature.

Try the following suggestions before cooking another pizza.

- Temperature set: 460°F
- Cooking time set: 8 minutes
- ton1: 14.5 seconds; toF1: 20 seconds
- Top heaters set-up 1 & 3 (unplug fuse #2)
- ton2: 20 seconds; toF2: 20 seconds
- Top end plug in closed position at the entry side, open at the exit side

After trying another pizza, let us suppose that there are the following characteristics:

- Internal temperature 160°F for a cheese and pepperoni pizza.
- Pizza light on top.
- Dough is still not cooked well, the pizza slice is not strong.
- Bottom has good color and cannot get darker.

The pizza definitely needs more internal temperature. We cannot increase the bottom heat because it is already as brown as it can get. A good suggestion in this case is to increase the cooking time. By increasing the cooking time, we will increase both top and bottom heat. Increasing the top heat in this case is good because the pizza was light on top. Since increasing the bottom heat will make it darker, we will have to decrease it.

- Temperature set: 440°F
- Cooking time set: 9:30 minutes
- ton1: 13.5 seconds; toF1: 20 seconds
- Top heaters set-up 1 & 3
- ton2: 20 seconds; toF2: 20 seconds
- Top end plugs open at the entry side, closed at the exit side

If the last set-up result had good characteristics, the next step is to perform a “load and trailing pizza test”. It is understood that the oven needs more heat under the load and less heat while it is idling. Q-Matic ovens are the only ovens in the market equipped with “load/no load” programmable adjustments.

# Cleaning & Maintenance

The recommended cleaning schedule shown below should be followed for proper performance and operation.

## **Daily:**

Cleaning should include the wire conveyor belt and the crumb pans. The belt can easily be cleaned by using a wire brush, allowing any foreign material to drop into crumb pans. The crumb pans can then be emptied and cleaned accordingly.

## **Every two weeks:**

Brush and clean the wire guard of the cooling fan(s) on the side(s) of the control panel.

## **Every three to six months:**

The inside of the oven should be cleaned to remove any materials that could have dropped off the conveyor belt. This process will include the removal of the conveyor belt and the conveyor belt supports. Follow the "Oven Assembly" instructions in their reverse order to take the oven apart. The oven interior, exterior and all parts removed should then be cleaned with an appropriate oven cleaner. The gas burners should be brushed clean and the ash should be vacuumed or blown away with compressed air.

Note: When taking the oven apart, conveyor belt must be rolled up. Otherwise belt will be upside-down with rethreading the belt as shown in the assembly instructions. Special attention should be given to the spark igniter and flame sensor position relative to the pilot, so proper ignition and flame supervision will be insured after reassembling the oven.

## **Every twelve months:**

A factory authorized service person should;

- Open and clean the inside of the control panel.
- Check and tighten the electrical connections.
- Check DC gear motor brushes for wear.

# Troubleshooting

Symptom	Possible Cause	Suggested Remedy
Bottom gas heaters will not fire.	<ul style="list-style-type: none"><li>- Pilot is not on</li><li>- Spark does not go on</li><li>- Combustion blower is not running</li></ul>	<ul style="list-style-type: none"><li>- Turn off both switches, wait 5 seconds and turn them on again. If the spark is on for 15-20 seconds and the pilot still does not fire: check gas supply, check the gap between the spark igniter and pilot (it should be 3/32).</li><li>- Check spark igniter connection and 24v supply to the ignition control.</li><li>- Check spark igniter gap.</li><li>- Replace or bypass the cool down cube timer.</li></ul>
Pilot & spark is on for 20 seconds and then shuts off.	<ul style="list-style-type: none"><li>- Flame sensor does not confirm flame</li><li>- Flame sensor is grounded</li></ul>	<ul style="list-style-type: none"><li>- Check flame sensor position. It should be engulfed in flame.</li><li>- Make sure the flame sensor doesn't touch any metal.</li></ul>
Pilot is on for more than 1 minute and the main gas heaters won't go on.	<ul style="list-style-type: none"><li>- On/off valve is not cycling</li></ul>	<ul style="list-style-type: none"><li>- Check solenoid valve connections.</li></ul>
Pilot is on, but shuts off when main gas heaters turn on.	<ul style="list-style-type: none"><li>- Gas pressure drops too much when the gas heaters turn on.</li></ul>	<ul style="list-style-type: none"><li>- Check gas pressure in the gas line. It should not drop below 7" W.C. (Natural gas) or 11" W. C. (L.P) when the gas heaters turn on.</li></ul>
Oven will not reach desired temperature.	<ul style="list-style-type: none"><li>- Pilot shuts off entirely or partially in the Q-80 models.</li></ul>	<ul style="list-style-type: none"><li>- Turn off both switches. Wait for 5 seconds and then turn them on again. Make sure pilot is on (both in Q-80).</li></ul>

# Troubleshooting

Symptom	Possible Cause	Suggested Remedy
Oven shuts off after several hours of running.	<ul style="list-style-type: none"> <li>- Flame sensor loses pilot flame contact.</li> <li>- Temperature has risen above 600°F or the high limit switch is out of adjustment thus shutting off the pilot.</li> <li>- Possible carbon buildup causing flame sensor grounding.</li> </ul>	<ul style="list-style-type: none"> <li>- Check flame sensor position and readjust.*</li> <li>- Readjust temperature set point or high limit temperature set point.</li> <li>- Clean carbon around flame sensor.*</li> </ul>
Top of pizza suddenly comes out too light, but the bottom is still all right.	<ul style="list-style-type: none"> <li>- One or more of the top heaters are malfunctioning.</li> <li>- It is happening under load only.</li> </ul>	<ul style="list-style-type: none"> <li>- Check heater fuses. Replace defective fuse and verify with Amp meter that each active heater is on when temperature controller calls for heat. *</li> <li>- Readjust HSC and int for top and bottom heaters.*</li> </ul>
Temperature controller will not light up but conveyor controller does.	<ul style="list-style-type: none"> <li>- The control circuit fuse for heat is blown</li> </ul>	<ul style="list-style-type: none"> <li>- Replace fuse on the front panel</li> </ul>
Conveyor belt will not move.	<ul style="list-style-type: none"> <li>- Control circuit fuse for the conveyor drive is blown.</li> <li>- Circuit breaker on the front panel is off.</li> <li>- Defective drive motor.</li> <li>- Motor turns but the sprocket is loose on the shaft.</li> </ul>	<ul style="list-style-type: none"> <li>- Replace fuse on the control panel.</li> <li>- Reset circuit breaker</li> <li>- *</li> <li>- Tighten the sprocket</li> </ul>

\* Denotes remedy is and should be performed by qualified personnel only.

Q-Matic Technologies cannot assume responsibility for damages as a result from servicing by unqualified personnel.

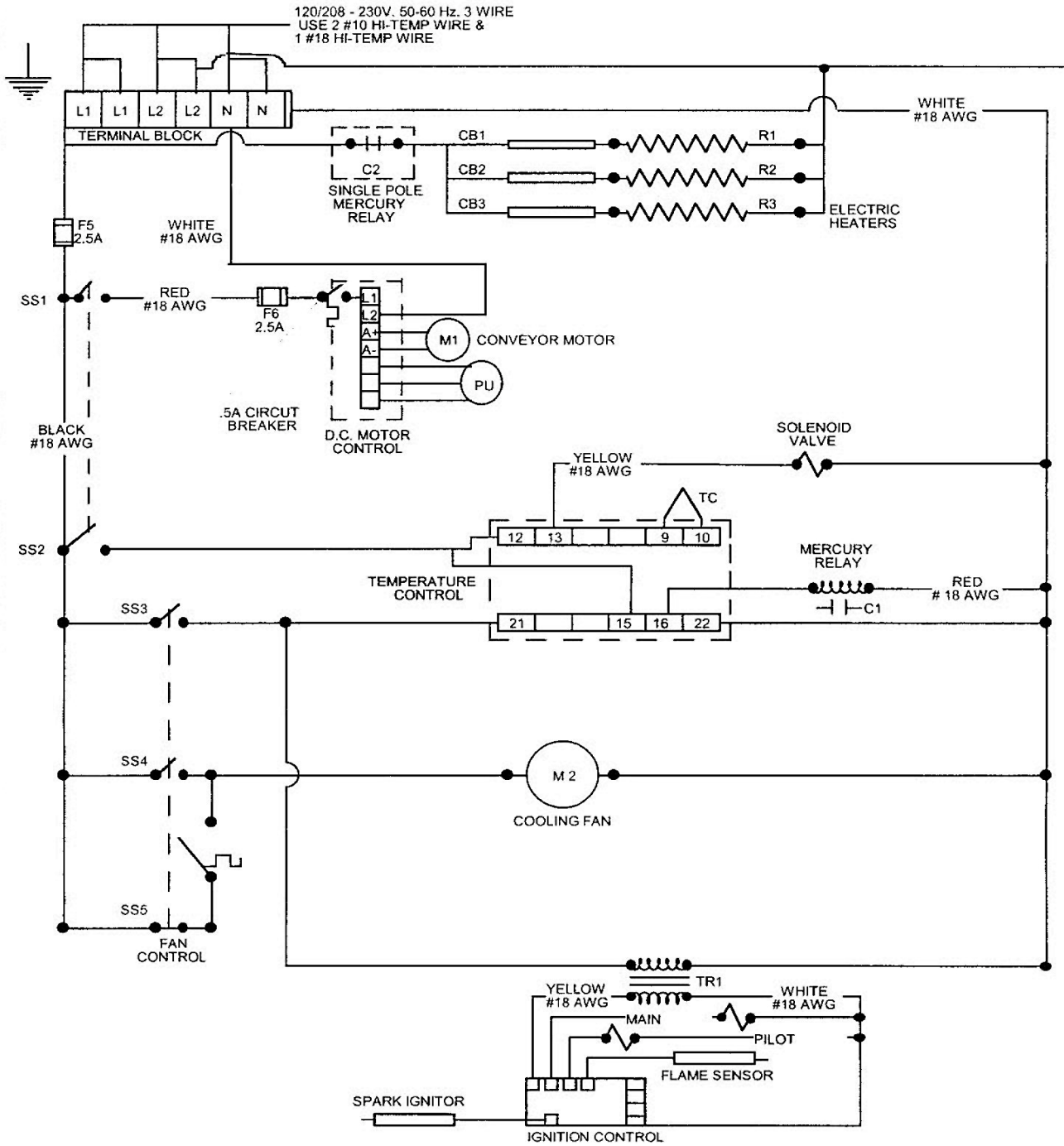

SCALE: NONE	APPROVED BY:	DRAWN BY: FAA
DATE: 10/23/00		REVISED:

**Q-36/36W WIRING DIAGRAM**



1351 Estes Street Gurnee IL 60031

DRAWING NUMBER  
**E00003**

208-240V. 50-60 Hz. 3 WIRE  
USE 3 #8 HI-TEMP WIRE

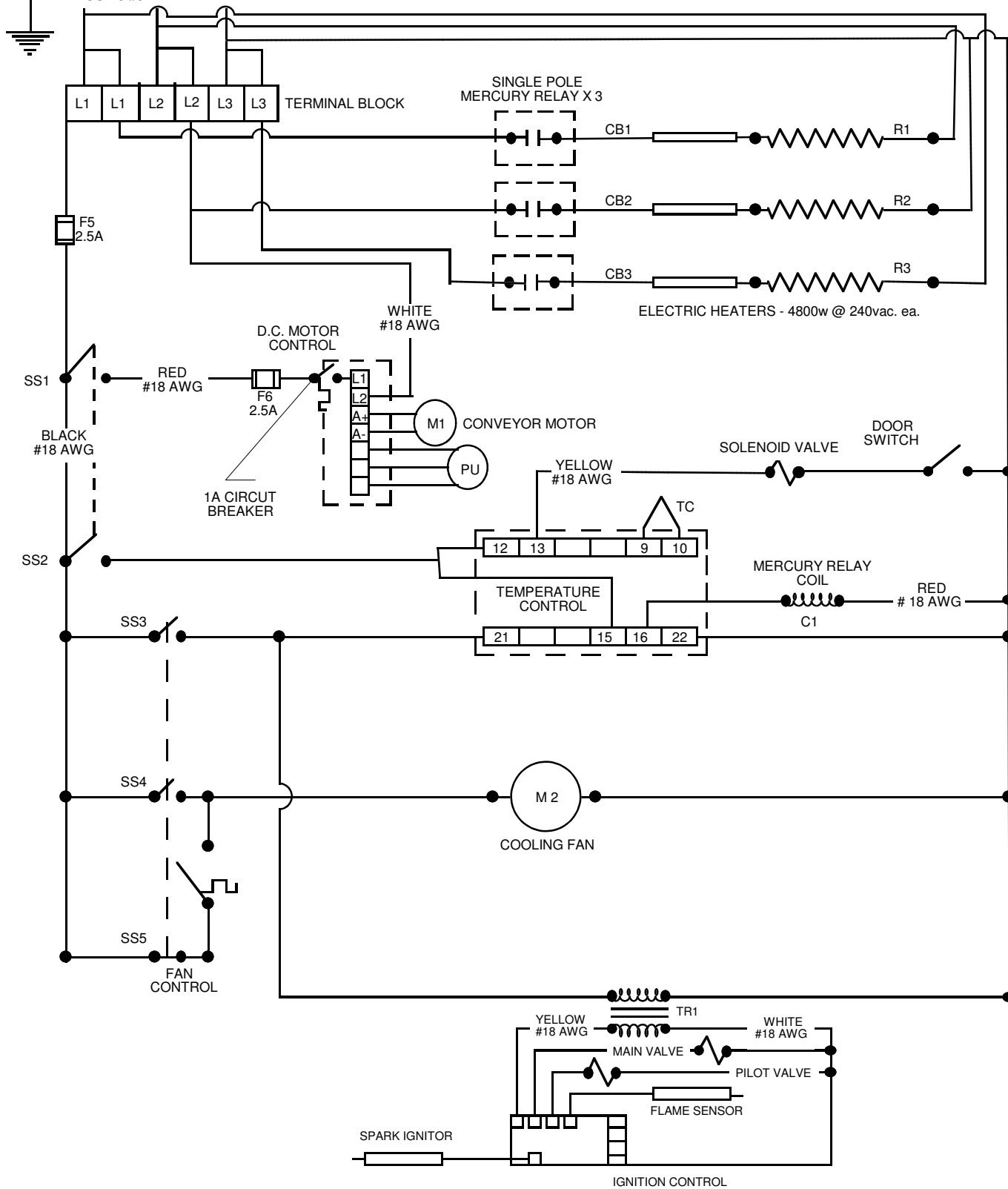

SCALE: NONE	APPROVED BY:	DRAWN BY: FAA
DATE: 3/21/05		REVISED:
<b>Q-36/36W Hybrid wiring</b>		
		DRAWING NUMBER
1351 Estes Street Gurnee IL 60031		<b>Q36H3PZ</b>

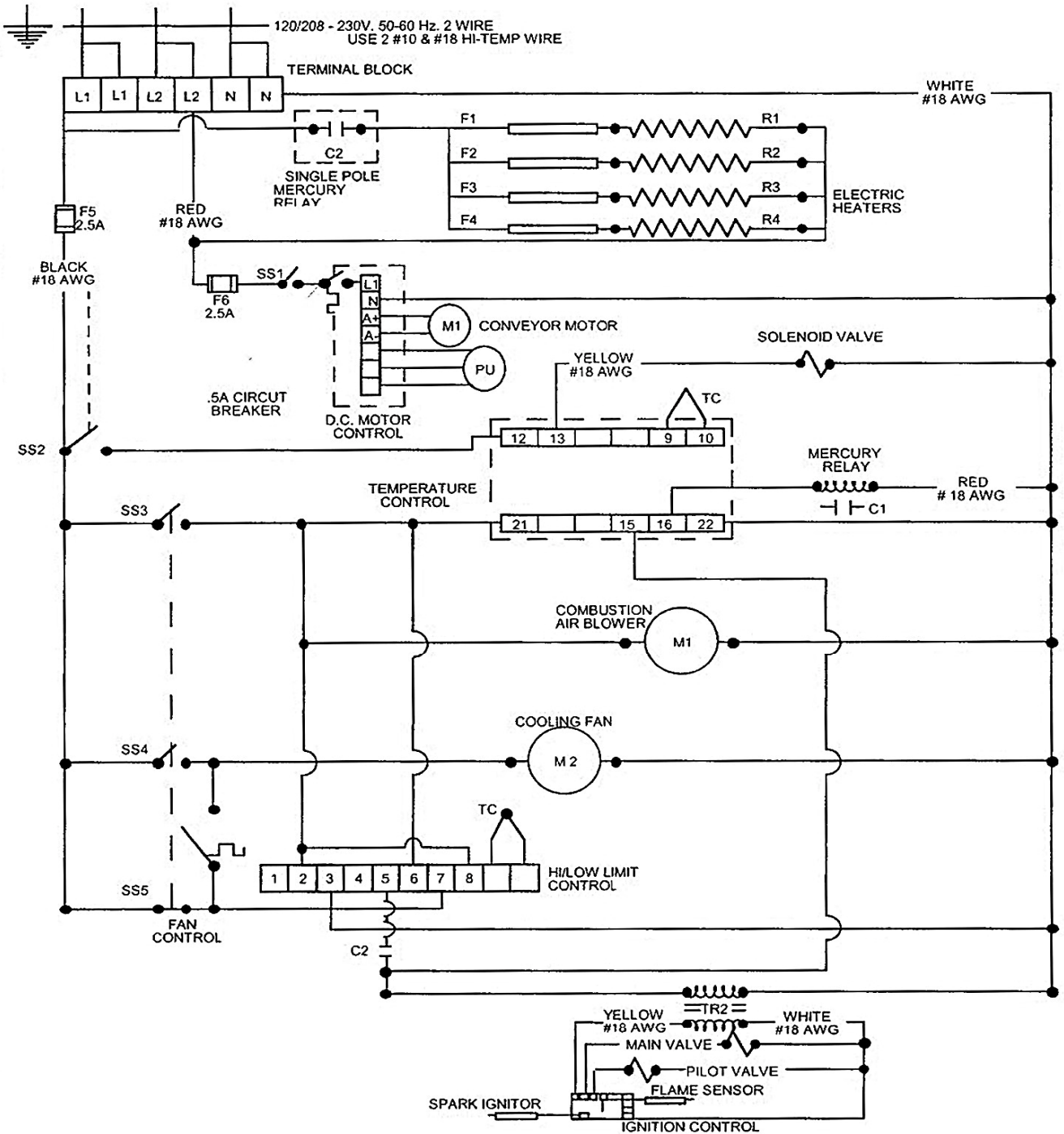

SCALE: NONE

APPROVED BY:

DRAWN BY: FAA

DATE: 10/23/00

REVISED:

**Q-55 WIRING DIAGRAM**



1351 Estes Street Gurnee IL 60031

DRAWING NUMBER

**E00001**

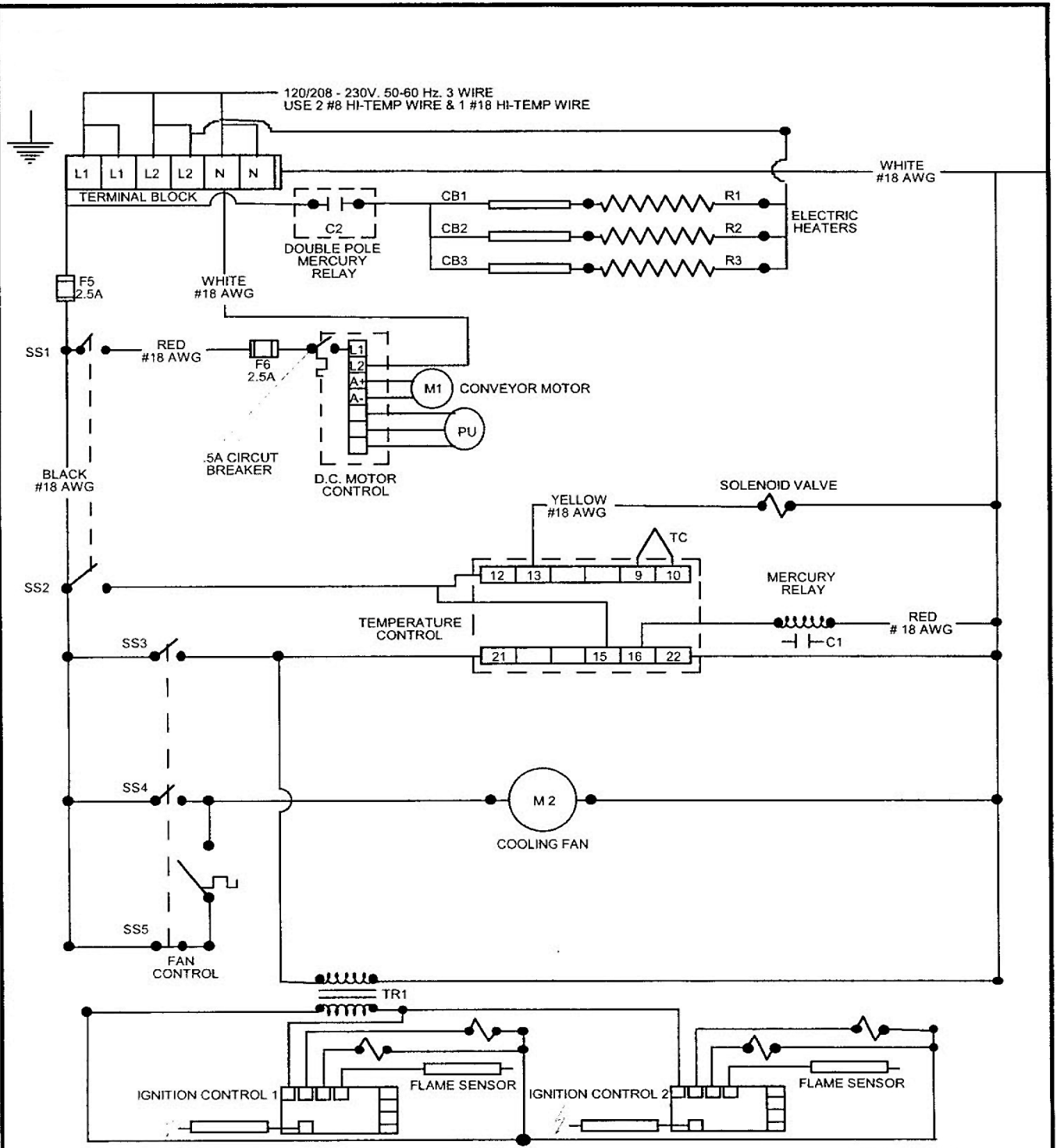

SCALE: NONE	APPROVED BY:	DRAWN BY:
DATE:		REVISED:
<b>Q-80 120/208 WIRING DIAGRAM</b>		
 1351 Estes Street Gurnee IL 60031		DRAWING NUMBER <b>E00002</b>



A Marmon Retail Services Company

1351 Estes Street Gurnee, IL 60031  
Tel. 847-263-7324 Fax 847-263-7367

# Product Test Form

Test # \_\_\_\_\_

Date \_\_\_\_\_

Product Description: \_\_\_\_\_

Cooking Time: \_\_\_\_\_

Temp. Set: \_\_\_\_\_ °F

## Bottom Heaters Set-up

ton1: \_\_\_\_\_ sec

toF1: \_\_\_\_\_ sec

HSC1: \_\_\_\_\_ °F

int1: \_\_\_\_\_ sec

## Top Heaters Set-up

ton1: \_\_\_\_\_ sec

toF1: \_\_\_\_\_ sec

HSC1: \_\_\_\_\_ °F

int1: \_\_\_\_\_ sec

Int. Temp. \_\_\_\_\_

Comments: \_\_\_\_\_

\_\_\_\_\_