

# QSB-12 & QSB-12S

## Service Manual



Service Opening – 13 1/4" x 9" x 23"  
 Rough Opening – QSB-12: 18 1/4" x 15 3/4"  
 Rough Opening – QSB-12S (W/O FLANGE): 28 1/4" x 15 3/4"  
 Rough Opening – QSB-12S (W/ FLANGE): 28 3/4" x 16"

### Click the Procedure to View

Operation and Maintenance Procedures	2
Rear Carriage Lock Assembly Replacement	3
Rail Replacement	4
Coil Spring Removal	5
Rear Loading Door Lock Assembly	6
Removal of Handle Assembly	7
Roller Wheel Replacement	8
Warranty Service Policy	9

## QSB-12 & QSB-12S

### Operation and Maintenance Procedures

#### Bullet Resistant Drawer Operation and Maintenance Procedures

##### Operation Procedures

- Unlock all locking mechanisms and ensure that the drawer is free of obstructions.
- Operate the drawer and return to the closed position.
- The attendant serving door must be closed and should not be opened while the attendant is sliding the drawer unit out to service the customer.



##### General Cleaning Guidelines:

- All drawers should be kept clean and free of debris.
- Slide rails should be frequently cleaned, oiled, and checked for debris and build-up.
- All cleaning fluids and applicators should be non-abrasive.

## Rear Carriage Lock Assembly Replacement - Part No. 8006

1. Remove 10 screws holding back panel to drawer.
2. Remove back panel.
3. Slide the 2 back sections apart to access the lock assembly.
4. Remove the 4 screws holding the lock assembly to the back panel. Note: Don't lose the pin during disassembly.
5. Replace with new lock assembly part # 8806.
6. To reassemble, reverse the above procedures using removable Loc-Tite on screws.

**Figure 1**

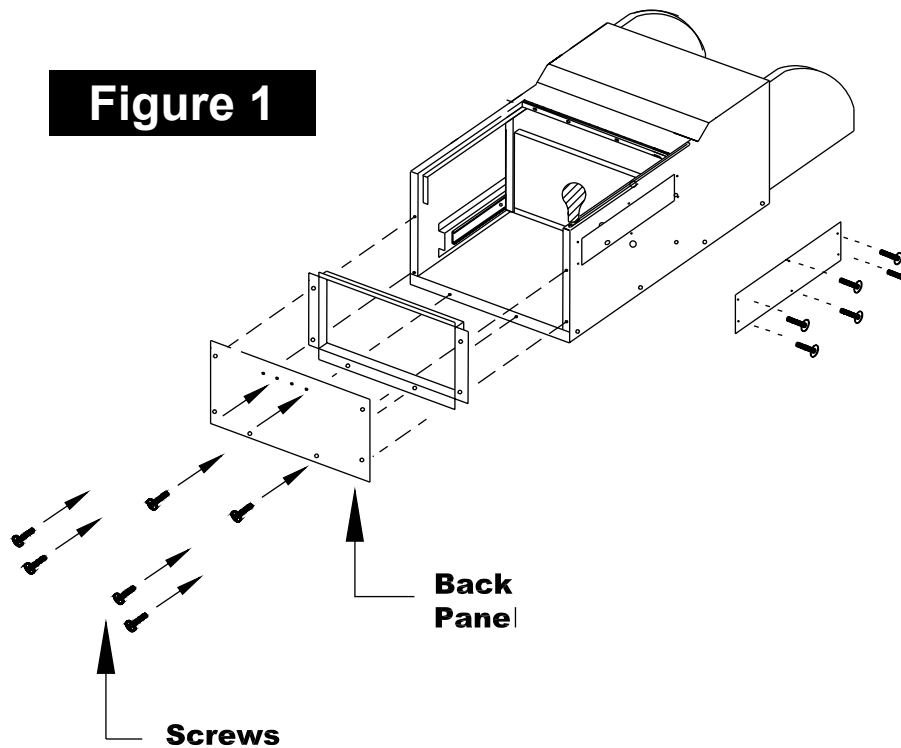

### Rear Carriage Lock Assembly

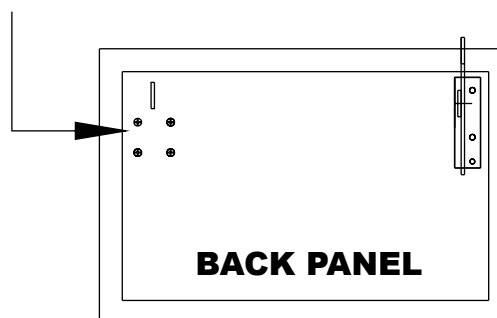

## Rail Replacement - Part No. 8008

1. Push open drawer; remove 4 screws on the bottom interior drawer that holds rails to the bottom of drawer.
2. Remove 4 screws on the bottom part of handle (part # 8807) from interior drawer.
3. Pull drawer out.
4. Move slide rail backward or forward until the 2 screws that are holding the slide rail to the side of the drawer is shown.
5. Remove the 2 screws and remove the slide rail.
6. After replacing the slide rails, reverse the above procedures to reassemble using removable Loc-Tite on screws.

### Figure 2

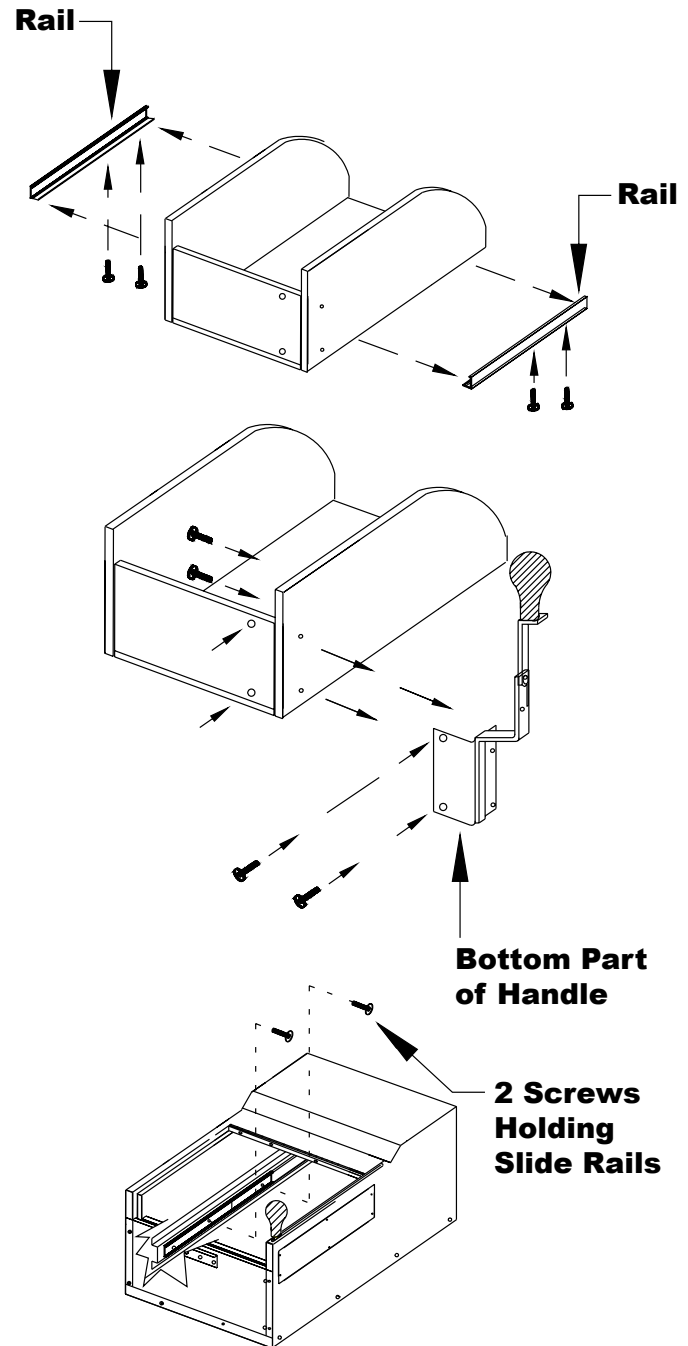

## Coil Spring Removal - Part No. 8021

1. Remove 2 bolts holding spring bracket assembly (part # 8808).
2. Remove spring from bracket.
3. Replace with new spring.
4. After replacing the spring, reverse the above procedures using removable Loc-Tite on screws.

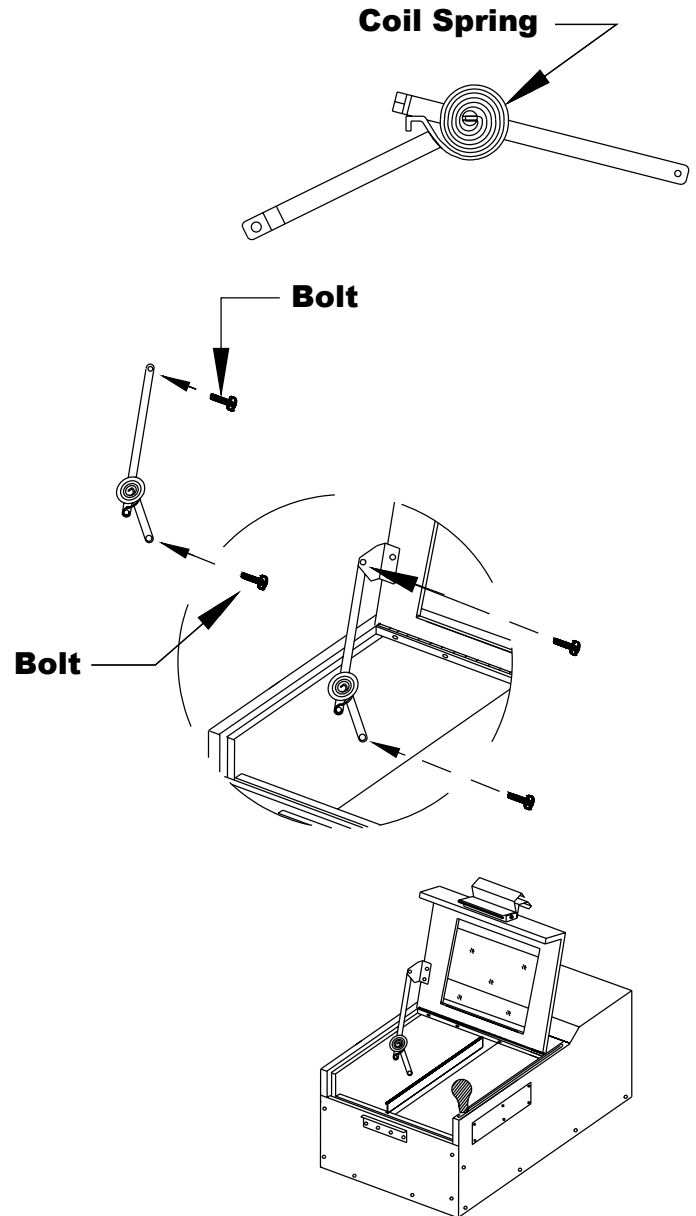
**Figure 3**

## Rear Loading Door Lock Assembly - Part No. 8805

1. Remove the 2 screws holding the lock assembly to back panel.
2. Replace with new lock assembly (part #8806).
3. Replace 2 screws using removable Loc-Tite.

**Figure 4**

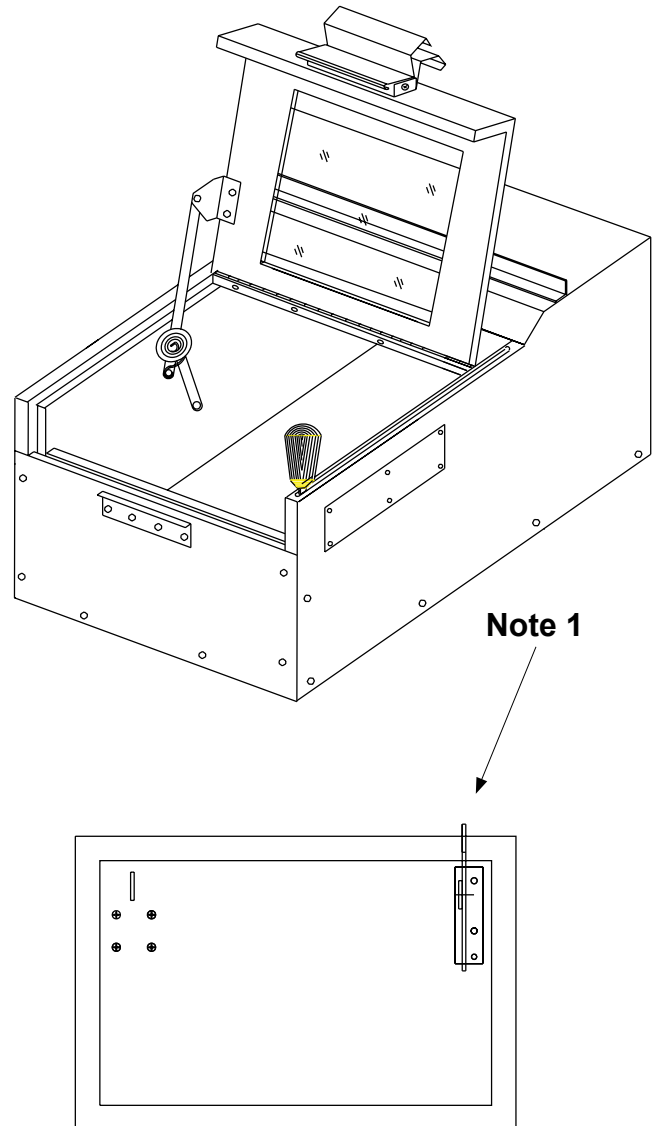

## Removal of Handle Assembly - Part No. 8807

1. Remove 6 screws on cover panel and remove cover.
2. Move handle unit 7/16" bolt show in hole slot.
  - a. Remove nut from inside drawer handle.  
The handle will now be in two parts.
3. To remove top handle, slide to front of the drawer pull up and out.
4. To remove bottom of handle. Remove 4 screws holding the handle to interior of drawer. Slide handle to hole slot and remove.
5. To replace, reverse the above procedures using removable Loc-Tite on screws.

**Figure 5**

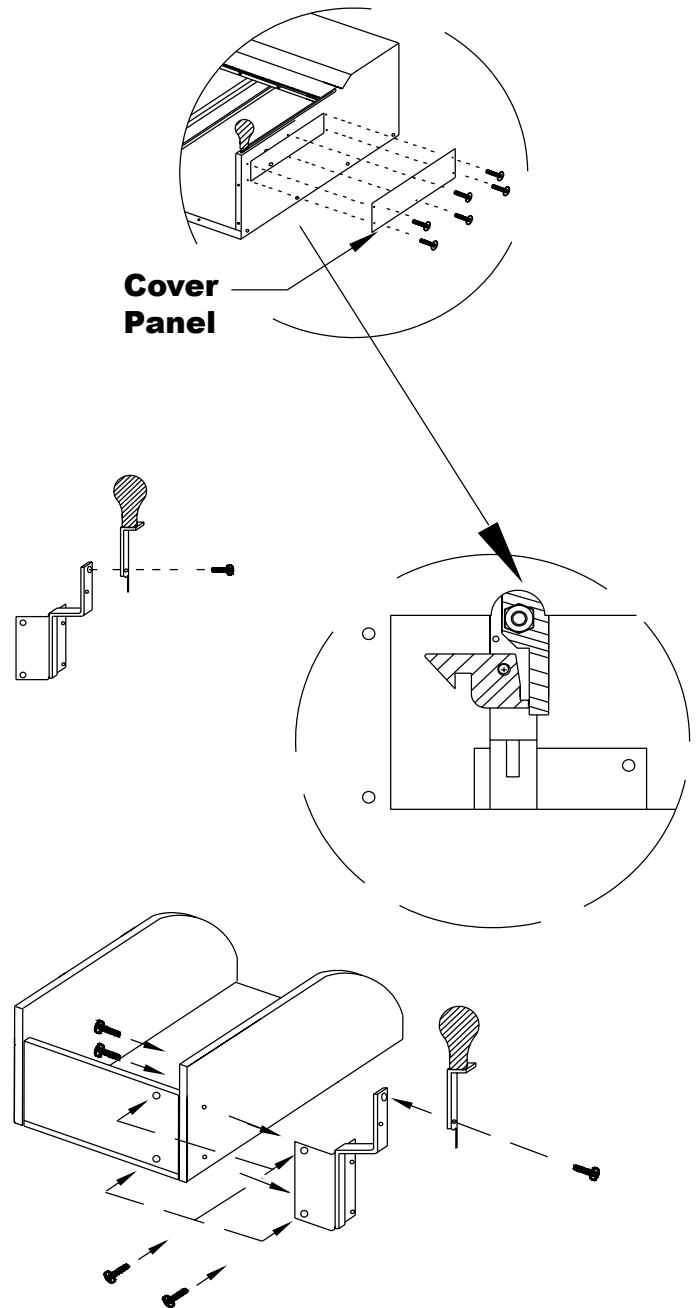

## Roller Wheel Replacement - Part No. 1032

1. Push open drawer and remove 4 screws on the bottom interior drawer that holds the rails to the bottom of drawer.
2. Remove 4 screws on the bottom part of handle (part #8807).
3. Remove screw holding the roller wheel.
4. Replace with new roller wheel (part #1032) using removable Loc-Tite on screws.

### Figure 6

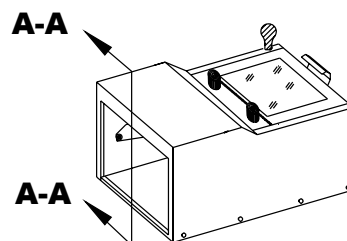
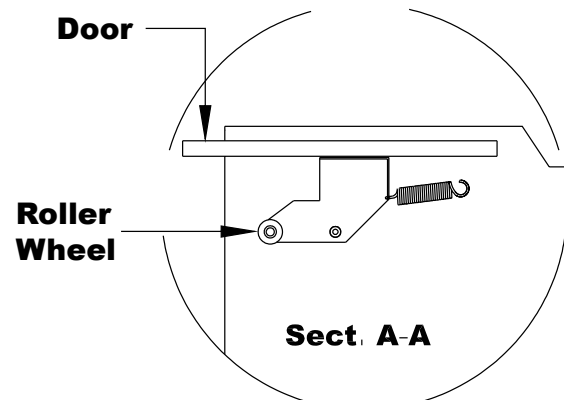
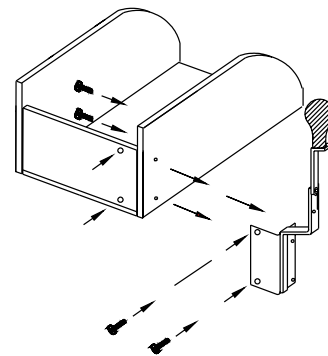
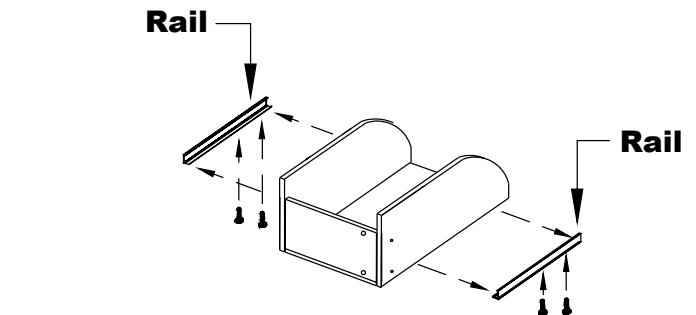

# Warranty Service Policy

1. Quikserv Corp. MUST be notified of a warranty situation before any work is performed. Otherwise, Quikserv Corp. will not be responsible to pay for unauthorized work.
2. Quikserv Corp. requires the following on each invoice submitted: an itemized account of work performed detailing hours charged and parts used, along with a short detailed description of the problem noted.
3. Quikserv Corp. will authorize a set dollar amount to be invoiced prior to performing services that will be rendered. This amount will be determined from the initial call to the service company as a fair maximum. If additional amounts are to be invoiced, they must be discussed with Quikserv Corp. prior to invoicing.
4. A service technician on a warranty service call needs to call our customer service department at (800) 388-8307 or (713) 849-5882 before leaving the job site.
5. A service company representative needs to call the store where the work is to be performed prior to going to that store. Set up a date and approximate time of arrival and if it is foreseen that the agreed upon time cannot be met, contact the store and make other arrangements.
6. Warranty parts sent to service companies are parts previously decided on that should cover the necessary repairs. Additional parts will be sent upon notification to Quikserv Corp.
7. Quikserv Corp. needs to be notified of any extra parts - either to be sent back or to be kept by the service technician. Any parts that were replaced must be returned to Quikserv Corp. if required verbally or on the service work order copy supplied with the parts sent by Quikserv Corp. If the parts are not returned, the part cost + mark up will be deducted from the service invoice.
8. A purchase order number will be given either verbally or on the service work order from Quikserv Corp. Please use this on all invoicing.
9. Work required on a window unit not covered under Quikserv's warranty must be reported to Quikserv Corp. before work is begun.
10. Quikserv's payment terms are net 30. The information above will help us assure the fastest and most efficient service possible. For further information or if you have any questions, please do not hesitate to contact us at (800) 388-8307.

Customer Service Department