

FM 96 WINDOW HARDWARE & STRAP DETAIL (SERIAL#15001 TO 19670)

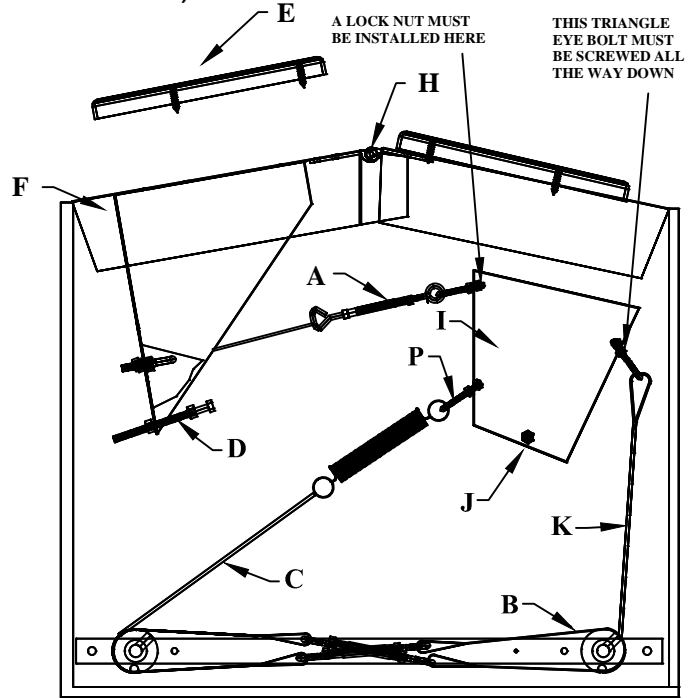

" BOTTOM VIEW "

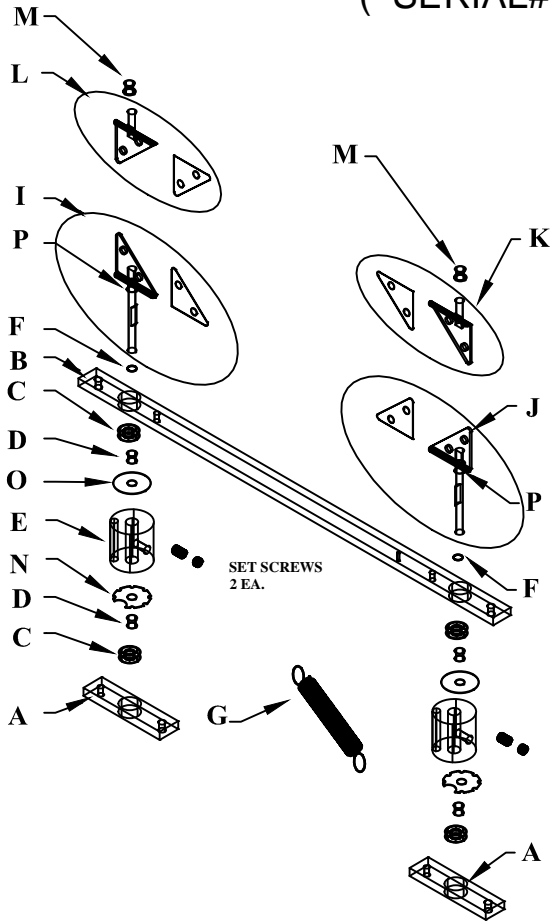
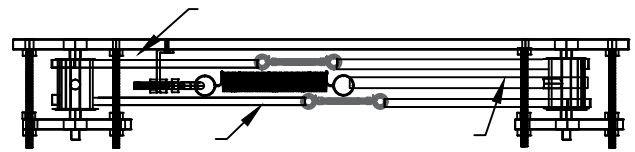

" EXTERIOR VIEW "

KEY NO	PART NO	DESCRIPTION
A	5582	BOTTOM BEARING BAR
B	5583	UPPER BEARING BAR
C	1012	BEARING
D	1004	ROLLER SPACER BUSHING
E	5587	ALUMINUM ROLLER \ SET SCREWS
F	1013	RUBBER O-RING
G	1005	RETURN SPRING
I	5590	L/H BOTTOM HINGE
J	5591	R/H BOTTOM HINGE
K	5593	R/H TOP HINGE
L	5592	L/H TOP HINGE
M	1006	TOP HINGE BUSHING
N	3631	BOTTOM RETAINER WASHER
O	3643	TOP RETAINER WASHER
P	1915	HINGE SPACER BUSHING

KEY NO	PART NO	DESCRIPTION
A	5564	PULL STRAP TO BAR ASSEMBLY
B	5560	ROLLER STRAP ASSEMBLY QTY (2)
C	5565	RETURN SPRING STRAP ASSEMBLY
D	5201	TRAVEL ADJUSTER
E	2103	PUSH PAD QTY (2)
F	5557	PUSH BAR ASSEMBLY
G	5599	COMPLETE SET OF STRAPS
H	1914	HINGE PIN
I	5600	LEVERAGE BRACKET
J	5217	LEVERAGE BRACKET BOLT
K	5563	ROLLER PULL STRAP ASSEMBLY
P	5214	EYE BOLT

NOTE: THIS DRAWING EMBODIES A CONFIDENTIAL PROPRIETARY DESIGN ORIGINATED AND OWED BY QUIKSERV CORP., AND IS SUBMITTED UNDER A CONFIDENTIAL RELATIONSHIP. ALL PATENT, MANUFACTURING, SALE RIGHTS REGARDING THE SAME ARE RESERVED EXCEPT TO THE EXTENT RIGHTS ARE EXPRESSLY GRANTED TO OTHERS. THE RECIPIENT AGREES BY ACCEPTING THESE DRAWINGS NOT TO SUPPLY OR DISCLOSE ANY INFORMATION REGARDING THEM TO ANY UNAUTHORIZED PERSON.

Quikserv Corp.
www.quikserv.com
1-800-388-8307

FM HARDWARE & STRAP DETAIL 15000 TO 19689

Submitted By:
Brian Coble

DATE:
5/14/2015

Sheet:
FM96-SD

FM WINDOW HARDWARE & STRAP DETAIL (SERIES PRIOR TO SERIAL#15000)

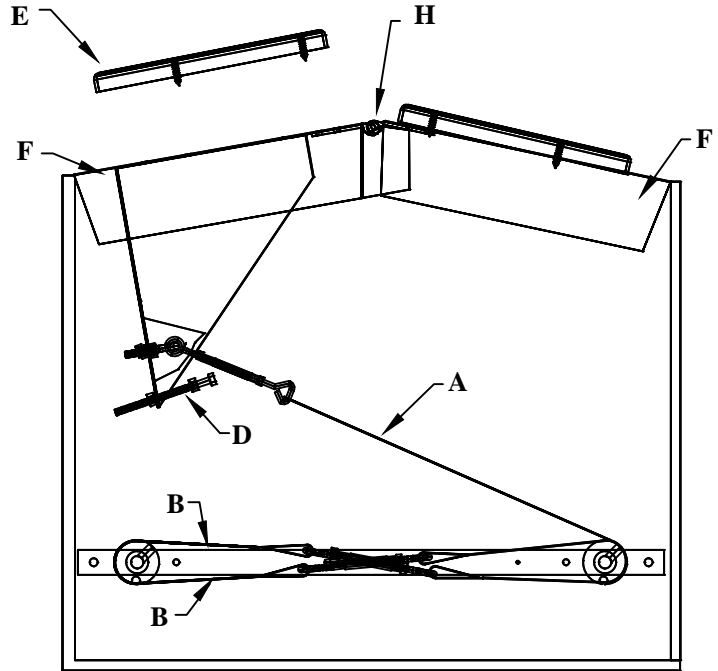
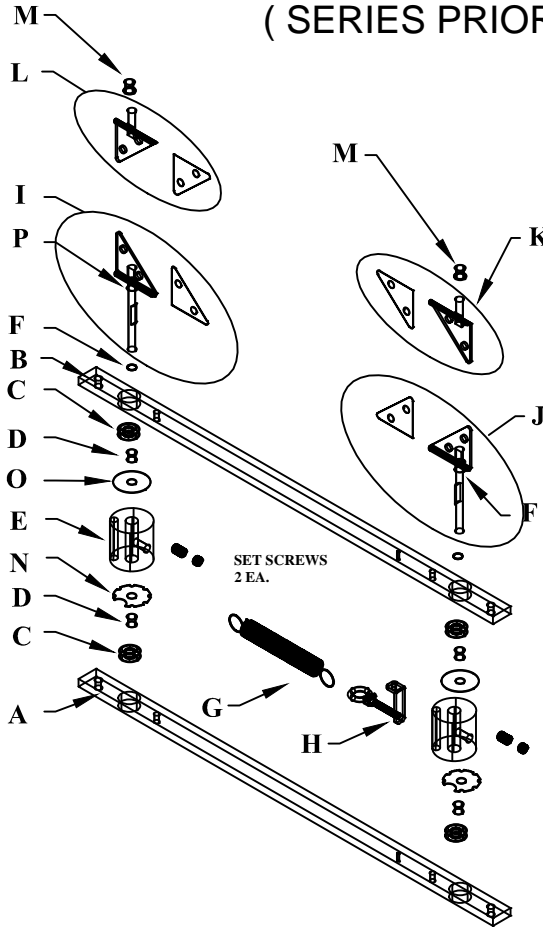

" BOTTOM VIEW "

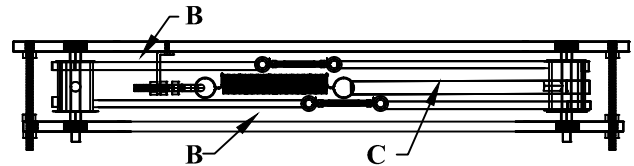

" EXTERIOR VIEW "

KEY NO	PART NO	DESCRIPTION
A	5522	BOTTOM BEARING BAR
B	5523	UPPER BEARING BAR
C	1012	BEARING
D	1004	ROLLER SPACER BUSHING
E	5587	ALUMINUM ROLLER \ SET SCREWS
F	1013	RUBBER O-RING
G	1009	RETURN SPRING
H	3702	RETURN SPRING BRACKET
I	5590	L/H BOTTOM HINGE
J	5591	R/H BOTTOM HINGE
K	5593	R/H TOP HINGE
L	5592	L/H TOP HINGE
M	1006	TOP HINGE BUSHING
N	3631	BOTTOM RETAINER WASHER
O	3643	TOP RETAINER WASHER
P	1915	HINGE SPACER BUSHING

KEY NO	PART NO	DESCRIPTION
A	5561	PULL STRAP ASSEMBLY
B	5560	ROLLER STRAP ASSEMBLY QTY (2)
C	5562	RETURN SPRING STRAP ASSEMBLY
D	5201	TRAVEL ADJUSTER
E	2103	PUSH PAD QTY (2)
F	5501	PUSH BAR ASSEMBLY
G	5594	COMPLETE SET OF STRAPS
H	1914	HINGE PIN

NOTE: THIS DRAWING EMBODIES A CONFIDENTIAL PROPRIETARY DESIGN ORIGINATED AND OWED BY QUIKSERV CORP., AND IS SUBMITTED UNDER A CONFIDENTIAL RELATIONSHIP. ALL PATENT, MANUFACTURING, SALE RIGHTS REGARDING THE SAME ARE RESERVED EXCEPT TO THE EXTENT RIGHTS ARE EXPRESSLY GRANTED TO OTHERS. THE RECIPIENT AGREES BY ACCEPTING THESE DRAWINGS NOT TO SUPPLY OR DISCLOSE ANY INFORMATION REGARDING THEM TO ANY UNAUTHORIZED PERSON.

Quikserv Corp.
www.quikserv.com
1-800-388-8307

FM HARDWARE & STRAP DETAIL UP TO 15000

Submitted By:
Brian Coble

DATE:
5/14/2015

Sheet:
FM-SD-O

**FM WINDOW
HARDWARE & STRAP DETAIL
(SERIAL # 19690 TO PRESENT)**

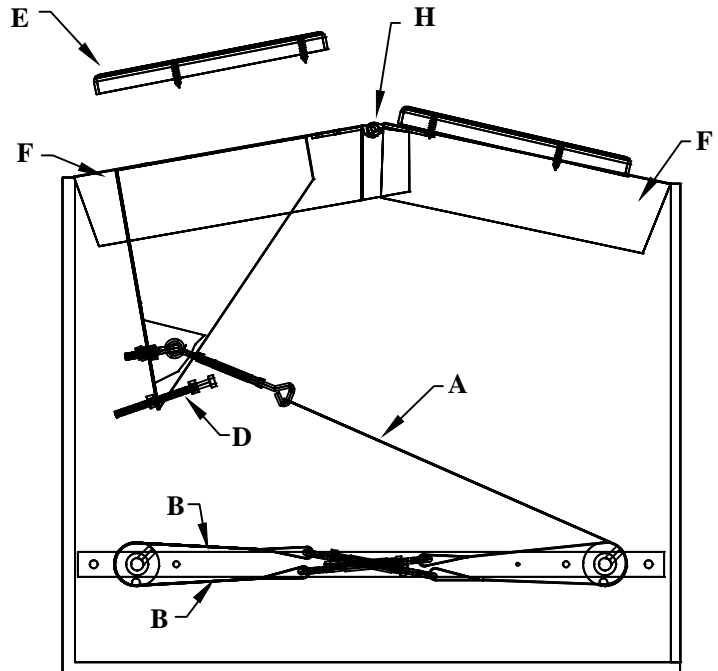
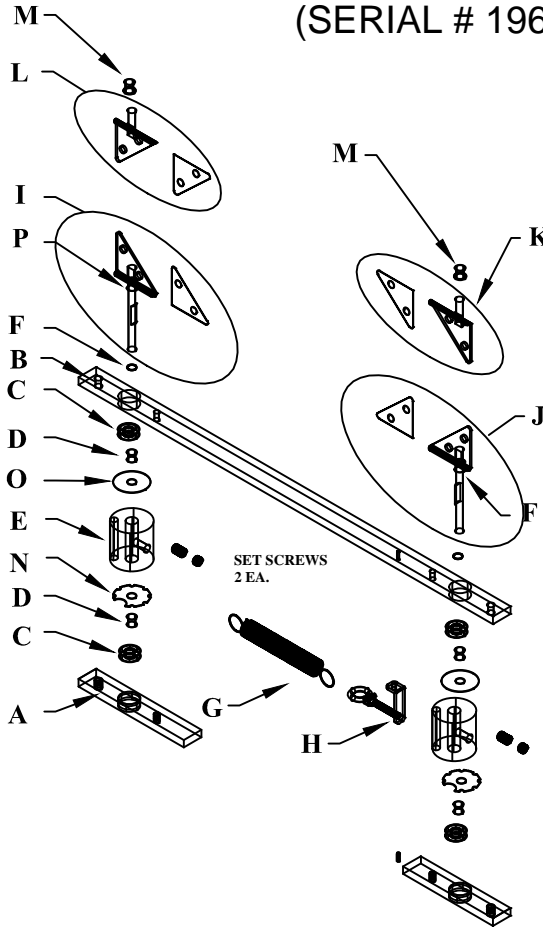

" BOTTOM VIEW "

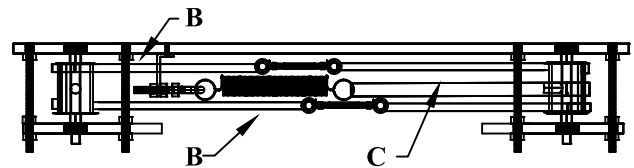

" EXTERIOR VIEW "

KEY NO	PART NO	DESCRIPTION
A	5582	BOTTOM BEARING BAR
B	5523	UPPER BEARING BAR
C	1012	BEARING
D	1004	ROLLER SPACER BUSHING
E	5587	ALUMINUM ROLLER \ SET SCREWS
F	1013	RUBBER O-RING
G	1009	RETURN SPRING
H	3702	RETURN SPRING BRACKET
I	5590	L/H BOTTOM HINGE
J	5591	R/H BOTTOM HINGE
K	5593	R/H TOP HINGE
L	5592	L/H TOP HINGE
M	1006	TOP HINGE BUSHING
N	3631	BOTTOM RETAINER WASHER
O	3643	TOP RETAINER WASHER
P	1915	HINGE SPACER BUSHING

KEY NO	PART NO	DESCRIPTION
A	5561	PULL STRAP ASSEMBLY
B	5560	ROLLER STRAP ASSEMBLY QTY (2)
C	5562	RETURN SPRING STRAP ASSEMBLY
D	5201	TRAVEL ADJUSTER
E	2103	PUSH PAD QTY (2)
F	5501	PUSH BAR ASSEMBLY
G	5594	COMPLETE SET OF STRAPS
H	1914	HINGE PIN

NOTE: THIS DRAWING EMBODIES A CONFIDENTIAL PROPRIETARY DESIGN ORIGINATED AND OWED BY QUIKSERV CORP., AND IS SUBMITTED UNDER A CONFIDENTIAL RELATIONSHIP. ALL PATENT, MANUFACTURING, SALE RIGHTS REGARDING THE SAME ARE RESERVED EXCEPT TO THE EXTENT RIGHTS ARE EXPRESSLY GRANTED TO OTHERS. THE RECIPIENT AGREES BY ACCEPTING THESE DRAWINGS NOT TO SUPPLY OR DISCLOSE ANY INFORMATION REGARDING THEM TO ANY UNAUTHORIZED PERSON.

Quikserv Corp.
www.quikserv.com
1-800-388-8307

FM STRAP DETAIL SERIAL # 19690 TO PRESENT

Submitted By:
Brian Coble

DATE:
6/1/2015

Sheet:
FM-SDP