

BI-PARTING SELF-CLOSING UNIT

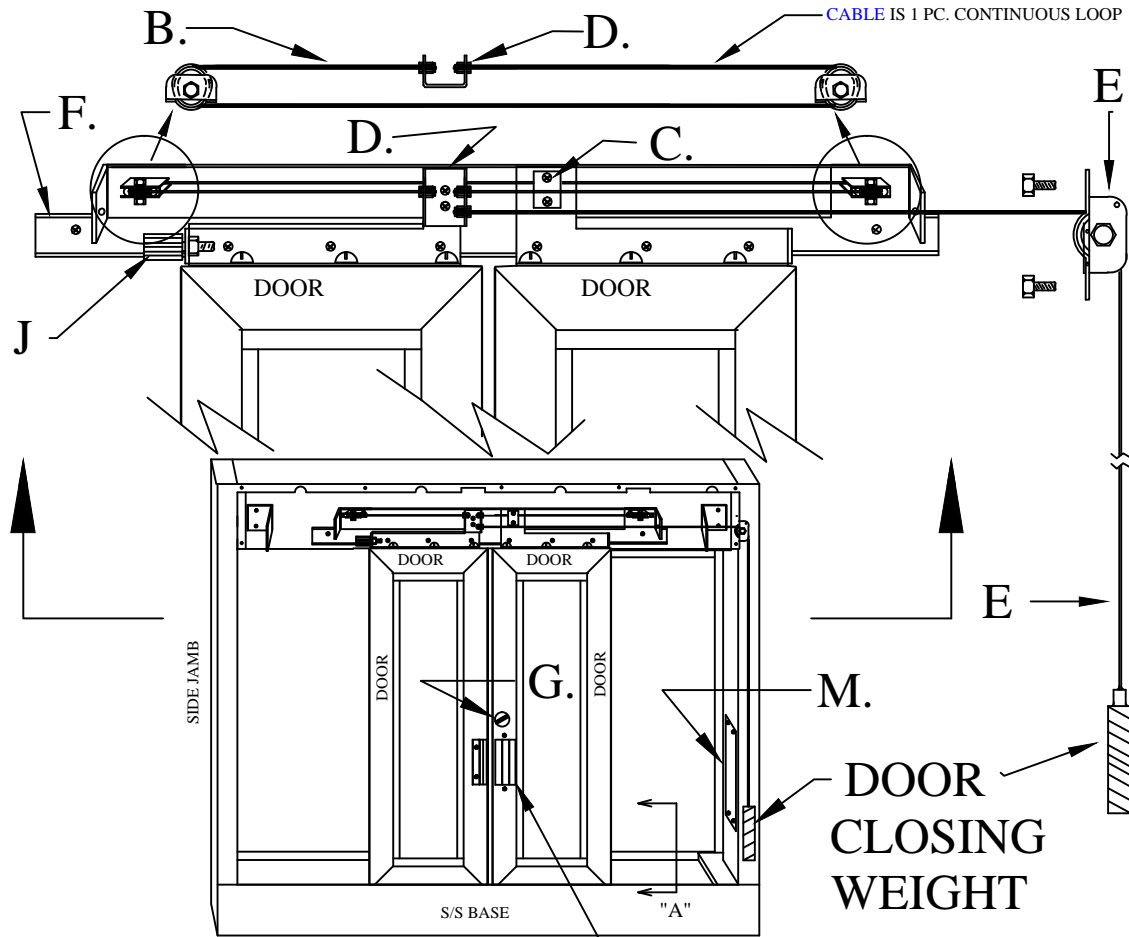

KEY NO.	PART NO.	DESCRIPTION
B		DOOR CABLE ASSEMBLY
	5659	BPSC-4236, 4836 & 4840
	5663	BPSC-5440
	5740	BPSC-7241
C	3805	CABLE PINCH BRACKET
D	3813	CABLE CONNECTION BK'T. CABLE WHEEL ASSEMBLY
E	5601	BPSC-4236, 4836 & 4840
	5715	BPSC-5440
	5741	BPSC-7241
F		SLIDE RAIL
	1916	BPSC-4236, 4836 & 4840
	1917 (2)	BPSC-7236, 7241 & 7252
G	2022	THUMB TURN LOCK
H	5586	STANDARD HANDLE
I	1017	BOTTOM DOOR GUIDE PIN
J	1054	MAGNET
M	3535	ACCESS COVER PLATE

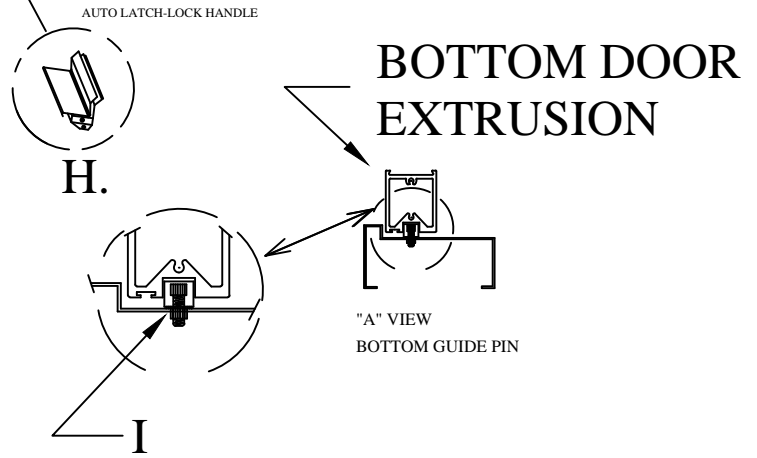

NOTE: THIS DRAWING EMBODIES A CONFIDENTIAL PROPRIETARY DESIGN ORIGINATED AND OWED BY QUIKSERV CORP., AND IS SUBMITTED UNDER A CONFIDENTIAL RELATIONSHIP. ALL PATENT, MANUFACTURING, SALE RIGHTS REGARDING THE SAME ARE RESERVED EXCEPT TO THE EXTENT RIGHTS ARE EXPRESSLY GRANTED TO OTHERS. THE RECIPIENT AGREES BY ACCEPTING THESE DRAWINGS NOT TO SUPPLY OR DISCLOSE ANY INFORMATION REGARDING THEM TO ANY UNAUTHORIZED PERSON.

Quikserv Corp.
www.quikserv.com
1-800-388-8307

BI-PARTING-SC PARTS BREAKDOWN

Submitted By:
Brian Coble

DATE:
4/4/2016

Sheet:
BP-SC-PARTS