

REPLACEMENT PARTS FOR ELECTRIC BI-PARTING SLIDERS

KEY NO.	PART NO.	DESCRIPTION
A	4413	ON/OFF SWITCH
C	4425	1/2A OR 3A 250V FUSE
D	5615	DRIVE MOTOR ASSM'Y.
E/J	4451	LIMIT SWITCH (2)
F	4460	P.C. BOARD
H	1052 1048	DRIVE BELT (BP-4841E) DRIVE BELT(BP-7241 & 7236E)
I	4401	CAPACITOR
L	1916 1917	SLIDE RAIL (BP-4841E) SLIDE RAIL QTY 2(BP-7241&7236)
N	5526	BEARING BLOCK AND PULLEY
P	4430	500MA 250V P.C. BOARD FUSE
R	4443	ELECTRIC BOLT LOCK
S	3598	BELT CLIP

NOTE: THIS DRAWING EMBODIES A CONFIDENTIAL PROPRIETARY DESIGN ORIGINATED AND OWED BY QUIKSERV CORP., AND IS SUBMITTED UNDER A CONFIDENTIAL RELATIONSHIP. ALL PATENT, MANUFACTURING, SALE RIGHTS REGARDING THE SAME ARE RESERVED EXCEPT TO THE EXTENT RIGHTS ARE EXPRESSLY GRANTED TO OTHERS. THE RECIPIENT AGREES BY ACCEPTING THESE DRAWINGS NOT TO SUPPLY OR DISCLOSE ANY INFORMATION REGARDING THEM TO ANY UNAUTHORIZED PERSON.

Quikserv Corp.
www.quikserv.com
1-800-388-8307

Electric BI-Parting Header Parts

Submitted By:
Brian Coble

Date:
11/10/2014

Sheet:
EBP-HP

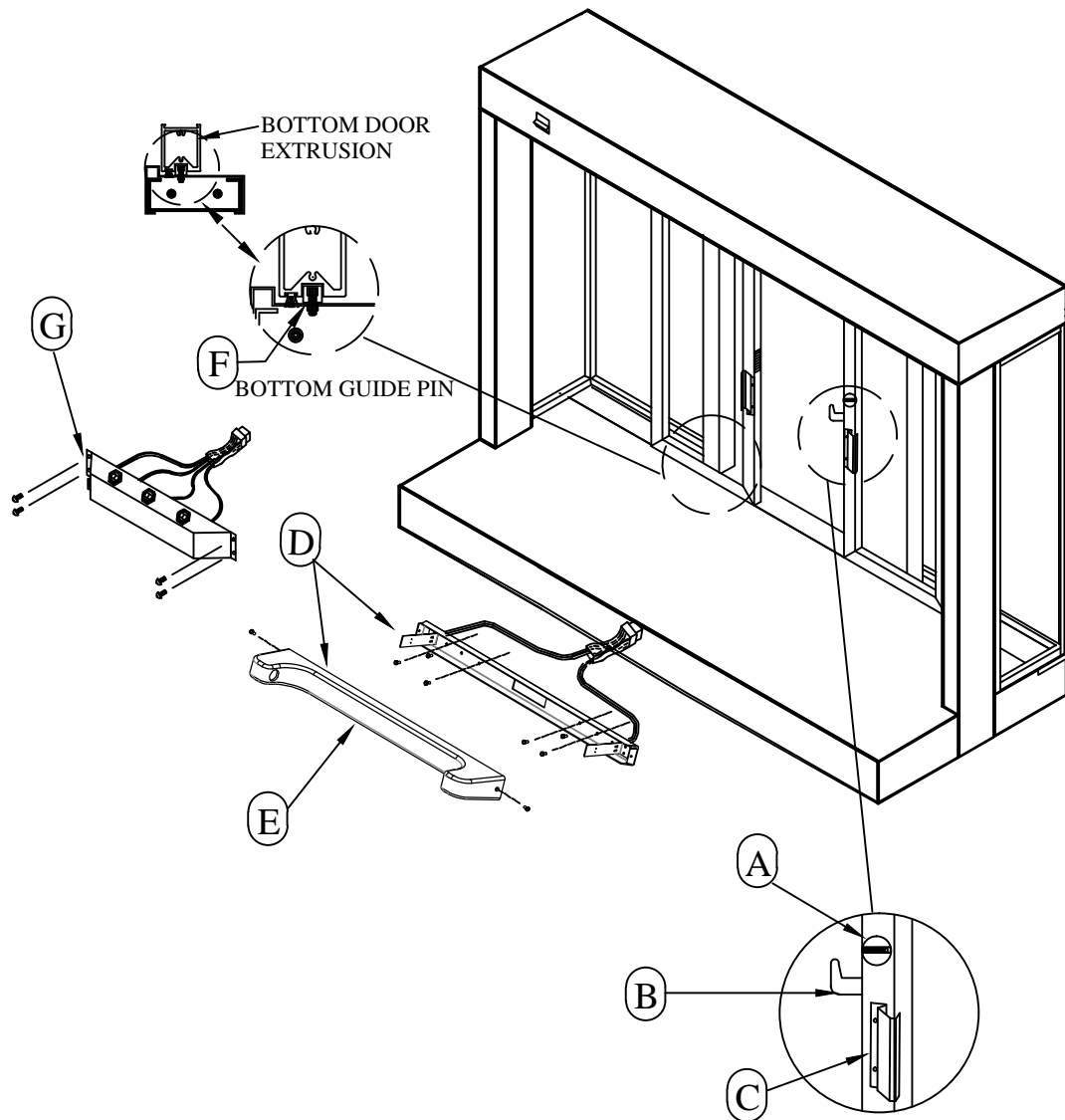

KEY NO.	PART NO.	DESCRIPTION
A	2022	THUMB TURN LOCK
B	2019	HOOK LOCK
C	3588	STANDARD HANDLE
D	5739	THRU BEAM EYE SET ASSEMBLY
E	2152	THRU BEAM PLASTIC COVER
F	1017	BOTTOM DOOR GUIDE (2 PER UNIT)
G	5604	UP-EYE SET (DISCONTINUED)

NOTE: THIS DRAWING EMBODIES A CONFIDENTIAL PROPRIETARY DESIGN ORIGINATED AND OWED BY QUIKSERV CORP., AND IS SUBMITTED UNDER A CONFIDENTIAL RELATIONSHIP. ALL PATENT, MANUFACTURING, SALE RIGHTS REGARDING THE SAME ARE RESERVED EXCEPT TO THE EXTENT RIGHTS ARE EXPRESSLY GRANTED TO OTHERS. THE RECIPIENT AGREES BY ACCEPTING THESE DRAWINGS NOT TO SUPPLY OR DISCLOSE ANY INFORMATION REGARDING THEM TO ANY UNAUTHORIZED PERSON.

Quikserv Corp.

www.quikserv.com
1-800-388-8307

Electric BI-Parting Hardware Parts

Submitted By:
Brian Coble

Date:
11/10/2014

Sheet:
EBP-HWP