

Holman[®] **CONVEYOR TOASTER**

MODEL
QCS2, QCSe2, RCS2, R2e SERIES
QCS3, QCSe3 SERIES

Installation and Operation Instructions

2M-Z10651 Rev. D 6/10/2011

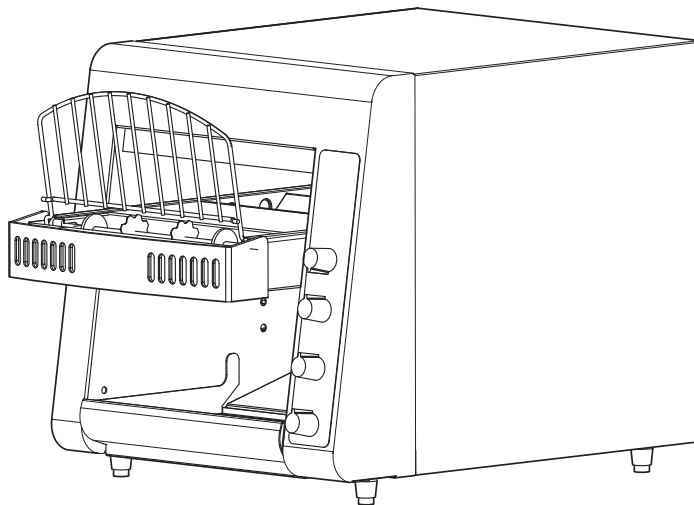

Q2-600H-208V



SAFETY SYMBOL



These symbols are intended to alert the user to the presence of important operating and maintenance instructions in the manual accompanying the appliance.

RETAIN THIS MANUAL FOR FUTURE REFERENCE NOTICE

Using any part other than genuine Star factory supplied parts relieves the manufacturer of all liability.

Star reserves the right to change specifications and product design without notice. Such revisions do not entitle the buyer to corresponding changes, improvements, additions or replacements for previously purchased equipment.

Due to periodic changes in designs, methods, procedures, policies and regulations, the specifications contained in this sheet are subject to change without notice. While Star International Holdings Inc., Company exercises good faith efforts to provide information that is accurate, we are not responsible for errors or omissions in information provided or conclusions reached as a result of using the specifications. By using the information provided, the user assumes all risks in connection with such use.

MAINTENANCE AND REPAIRS

Contact your local authorized service agent for service or required maintenance.

Please record the model number, serial number, voltage and purchase date in the area below and have it ready when you call to ensure a faster service.

Model No. _____
Serial No. _____
Voltage _____
Purchase Date _____

Authorized Service Agent Listing

Reference the listing provided with the unit

OR

for an updated listing go to:

Website: www.star-mfg.com
E-mail Service@star-mfg.com
Telephone: (800) 807-9054 Local (314) 781-2777

Service Help Desk

Business Hours: 8:00 am to 4:30 p.m. Central Standard Time

Telephone: (800) 264-7827 Local (314) 781-2777

Fax: (800) 396-2677 Local (314) 781-2714

E-mail Parts@star-mfg.com
Service@star-mfg.com
Warranty@star-mfg.com

Website: www.star-mfg.com

Mailing Address: Star International Holdings Inc., Company
10 Sunnen Drive
St. Louis, MO 63143
U.S.A

TABLE OF CONTENTS

General Installation Data	4
Uncrating & Inspection.....	4
Assembly & Installation	4
Electrical Connection.....	4
QCS & RCS	
Operation	5
Cooking Procedures	5
Toaster Components	5
Daily Operation	6
Operating Hints & Safety	6
QCSe & RCSe	
QCSe Operation	7
Start-up	8
Daily Operation	8
Operating Hints & Safety	8
Toaster Components	8
Programing	
Conveyor Speed	9
Programing Values for Menu Items	9
Cleaning	10
Maintenance Procedures	11
Trouble Shooting Guide.....	12
Warranty.....	13
Wiring Diagrams	
QCS2 & 3, RCS2 & 3, wired series	14
QCS2 & 3, RCS2 & 3, wired parallel	15
QCS2 & 3, RCS2 & 3, 3 wired in series	16
QCS2, RCS2 w/fan switch series	17
QCS2 & 3, RCS2 & 3, 3 wired in series w/bun mode	18
QCSe, 4 wired in series	19
QCSe, 6 wired in series	20
QCSe, 6 wired in parallel	21
QCS3, 6 wired in series, with fuses.....	22
Exploded View	24
Parts List	
QCS2, QCSe2 & RCS2, RCSe2.....	25 - 28
QCS3 & QCSe3.....	29 - 31



GENERAL INSTALLATION DATA

This equipment is designed and sold for commercial use only by personnel trained and experienced in its operation and is not sold for consumer use in and around the home nor for use directly by the general public in food service locations.

Before using your new equipment, read and understand all the instructions & labels associated with the unit prior to putting it into operation. Make sure all people associated with its use understand the units operation & safety before they use the unit.

All shipping containers should be checked for freight damage both visible and concealed. This unit has been tested and carefully packaged to insure delivery of your unit in perfect condition. If equipment is received in damaged condition, either apparent or concealed, a claim must be made with the delivering carrier.

Concealed damage or loss - if damage or loss is not apparent until after equipment is unpacked, a request for inspection of concealed damage must be made with carrier within 15 days. Be certain to retain all contents plus external and internal packaging materials for inspection. The carrier will make an inspection and will supply necessary claim forms.

INSPECTION & ASSEMBLY

UNCRATING AND INSPECTING

Unpack the unit and components from the shipping container. Remove all visible packing material and those from inside the cooking chamber. If damage is discovered, file a claim immediately with the carrier that handled the shipment. Do not operate the unit if it was damaged during shipping.

ASSEMBLY AND INSTALLATION

The unit was shipped fully assembled and ready to plug into a standard outlet specified for its voltage and amp draw. If improper electrical supply is determined, contact a qualified electrician prior to using the unit. Removal and replacement of the power cord and plug will void the warranty. For assistance, contact your local authorized service agent for service or required maintenance.

Level unit using the adjustable feet under the unit (approximately 1/2" adjustment).

Before using the unit for the first time, wipe down the exterior with a damp cloth.

Allow enough space around the toaster for adequate ventilation. Do not operate the unit without the crumb tray properly positioned. Overheating and poor toasting may occur. Read all labels on the unit and follow their instructions.



ELECTRICAL CONNECTION

Before making any electrical connection to this unit, check that the power supply is adequate for the voltage, amperage and requirements stated on the rating plate.

A wiring diagram is included herewith.

Disconnect the unit from the power source before installing or removing any parts.



Be absolutely sure that the ground connection for the receptacle is properly wired. Do not connect equipment to power without proper ground connections. Improper grounding may result in personal injury or fatality.

DO NOT CUT OR REMOVE THIS PLUG OR GROUNDING PRONG FROM THE PLUG.



CONNECT/PLUG UNIT INTO DEDICATED A.C. LINE ONLY SPECIFIED ON THE DATA PLATE OF THE UNIT.

OPERATION

ROTARY POWER SAVER SWITCH

For toasters equipped with a Rotary Power Saver Switch, turn clockwise or counterclockwise to get in the following positions.

FULL POWER

When in this position your equipment is at full power and ready to use.

OFF ROTARY

Two off positions are provided, a single rotation to either direction will shut the unit off.

STANDBY

The standby position reduces the power consumption by 75%. Using this position during the quiet times will save electricity, and keep the toaster warm. When needed, turn the switch to FULL POWER. Recovery time is about 30 seconds.



CERTAIN SURFACES ARE EXTREMELY HOT DURING OPERATION AND CARE SHOULD BE TAKEN WHILE USING THIS UNIT.

COOKING PROCEDURES

BREAD TOASTING

Some toasters are equipped with a swinging heat shutter at the toaster entrance. This shutter will move out of the way as the product passes under it.

- 1) Turn the power saver to FULL POWER.
- 2) Set the conveyor speed to HIGH.
- 3) If your toaster is equipped with separate top and bottom heat controls set them both at HIGH.
- 4) Allow warm up time of 5 to 10 minutes.
- 5) Place a sample product on the conveyor belt to test the settings.
 - If toasting is too light, turn conveyor speed control counterclockwise to a slower speed.
 - If toasting is too dark, turn heat control to a lower heat.

(NOTE: Some products may require adjustment of the top and bottom heat controls in order to achieve the desired results)

TOASTER COMPONENTS

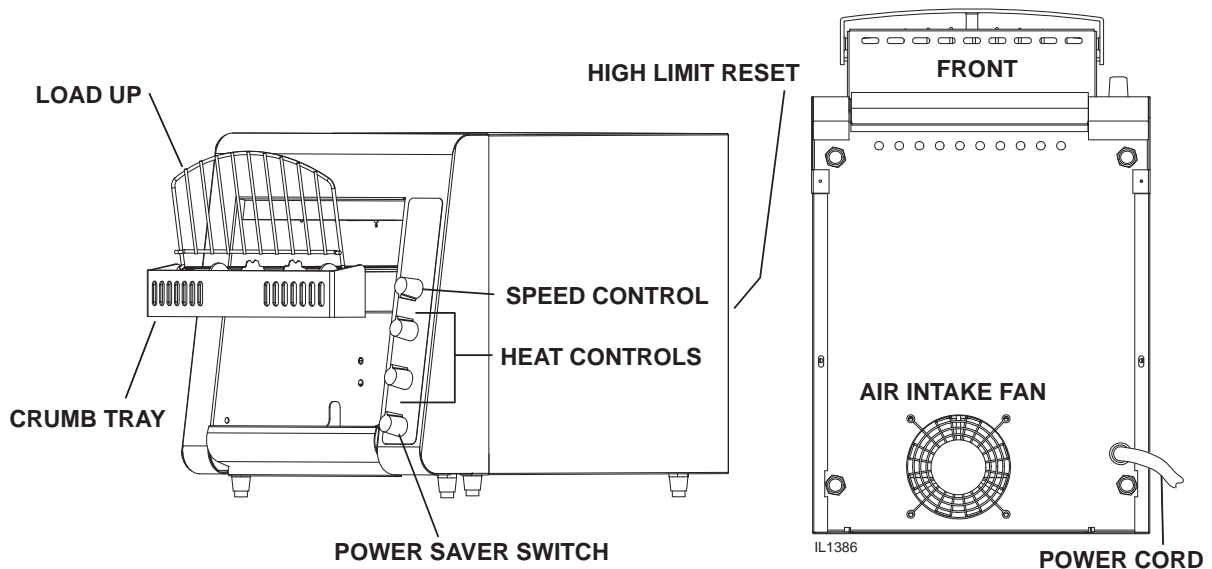



DAILY OPERATION

Check the power cord to insure that it is plugged into a proper outlet.

Set the heat control knobs to desired temperature.

Always allow 10 minutes of preheat time before loading the unit with product. Failure to allow sufficient preheat time will result in unsatisfactory cooking until the unit reaches operating temperature.

OPERATING HINTS AND SAFETY

Disconnect power to the unit with the switch at the end of each day of operation.

Do not leave the unit in operation without an attendant.

Turn Power Saver Switch to Standby during idle periods. It will take only a few minutes to regain operating temperature.

Do not leave the unit at high temperature when not in use or during idle periods. This will cause food particles and grease film to carbonize.



CAUTION

QCS_e & RCSe OPERATION

The Holman QCS_e conveyor toaster comes with pre-programmed factory default settings for TOAST, MUFFINS, and BAGELS. The operator may change these setting at any time. A button labeled OTHER is provided to allow the operator to program settings for additional product(s).



Press TOAST and TST will appear in the display.

Press MUFFIN and MUF will appear in the display.

Press BAGEL and BGL will appear in the display.

Press OTHER and OTH will appear in the display.

LIGHT and **DARK** buttons are used to change the conveyor speeds when in toast, muffin, or bagel modes.

Pressing the **(LIGHT)** button once will increase the conveyor speed by 15%. Pressing twice **(XLIGHT)** will increase the conveyor speed by 30%.

Pressing the **(DARK)** button once will decrease the conveyor speed by 10%. Pressing twice **(XDARK)** will decrease the conveyor speed by 20%.

Note: After 60 seconds the conveyor speed will return to the pre-programmed setting.

The factory default settings are as follow:

TOAST AND OTHER

TOP HEAT	9
BOTTOM HEAT	9
CONVEYOR	59

BAGEL:

TOP HEAT	9
BOTTOM HEAT	9
CONVEYOR	24

OTHER:

TOP HEAT	9
BOTTOM HEAT	9
CONVEYOR	59

POWER SAVER:

TIME (minutes)	60
HEAT	5

The QCS_e toaster is equipped with a Power Saver Switch (SAVER) that reduces the power used by the toaster after a pre-programmed period of time. This Power Saver Switch has three modes:

ON: Unit is in pre-programmed power saving setting.

OFF: Power Saver mode is turned off.

AUTO ON: Power Saver turns on when there has been no activity for a programmed length of time.

The operator may adjust the level of power reduction for the saver mode. (Note: conveyor may move slowly when in saver mode.)

Two buttons (+) and (-) are used when increasing or decreasing the value of each programmable setting.

A red LED light located at the lower portion of the control panel label will indicate if the value for top heat, bottom heat or conveyor speed is being adjusted.



CAUTION

CERTAIN SURFACES ARE EXTREMELY HOT DURING OPERATION AND CARE SHOULD BE TAKEN WHILE USING THIS UNIT.

START UP

When the toaster has been plugged into a suitable outlet and power supply, the word **OFF** will be displayed on the L.E.D. read out.

- A. Press the **ON/OFF** button once to turn on the toaster. The toaster will now enter into pre-heat and **PREHT** will be displayed (the elements will begin to glow but the conveyor and fan motor will not turn on).
- B. **After one minute**, the fan motor will turn on and the conveyor will begin turning at the previously saved setting (for initial start up, the drive motor will operate at the factory default setting).
- C. **After four minutes**, the display will show the last used program selection i.e. **TOAST, BAGEL, MUFFIN** or **OTHER** (for initial startup, **TOAST** will be the last program selected).

DAILY OPERATION

Check the power cord to insure that it is plugged into a proper outlet.
 Press the **ON/OFF** button once to turn the toaster on.
 Press the button a second time to turn the toaster off.

NOTE: When the toaster is turned off, the fan and conveyor motors will continue to run for five minutes. The words **COOL** and **DOWN** will be alternately displayed during that time. After five minutes, the word **OFF** will be displayed until the **ON/OFF** button is pressed again.

For units equipped with a **POWER SAVER** feature, the three operating modes are:

- ON** Unit has entered the pre-programmed level of power savings.
- OFF** Power Saver feature is turned off.
- AUTO** If the toaster has been idle for a pre-set period of time, the unit enters Power Saver mode until one of the menu buttons has been pressed.

Once the toaster has been pre-heated, the menu buttons can be pressed to change to **TOAST, BAGEL, MUFFIN, or OTHER.**



OPERATING HINTS AND SAFETY

Disconnect power to the unit with the **ON/OFF** button at the end of each day of operation.

Do not leave the unit in operation without an attendant.

Do not leave the unit at high temperature when not in use or during idle periods. This will cause food particles and grease film to carbonize.

TOASTER COMPONENTS

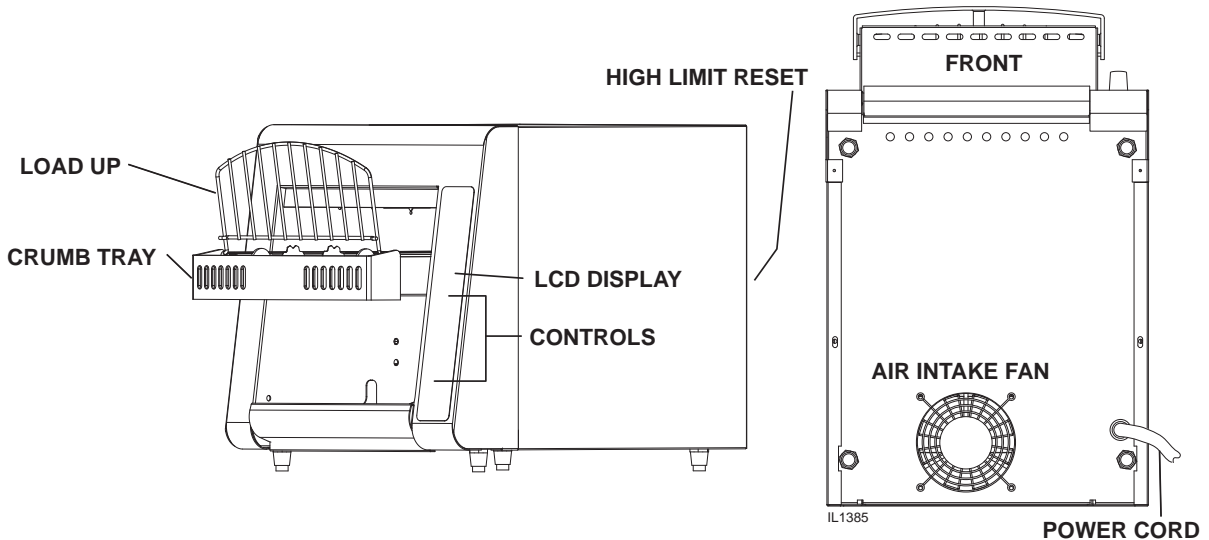

PROGRAMMING

A. CONVEYOR SPEED (temporary setting)

The conveyor speed is programmable with a range from 0 to 99 with 0 being the slowest and 99 being the fastest. Each menu item can have independent conveyor speed settings.

The *LIGHT* and *DARK* buttons can be used to temporarily change the conveyor speed. Pressing the *LIGHT* button once will increase the conveyor speed by 15%. The word **LIGHT** will be displayed. Pressing twice will increase the conveyor speed by 30% and **XLIGHT** will now be displayed.

Pressing the *DARK* button once will decrease the conveyor speed by 15%. The word **DARK** will be displayed. Pressing twice will decrease the conveyor speed by 30% and **XDARK** will now be displayed.

NOTE: After 60 seconds, the conveyor speed will return to the pre-programmed setting.

WHEN USING THE LIGHT AND DARK BUTTONS TO ADJUST THE CONVEYOR SPEED FOR A SINGLE ORDER OF PRODUCT, IT IS IMPORTANT TO REMEMBER TO ALLOW THE PRODUCT ALREADY IN THE TOASTER TO EXIT BEFORE CHANGING THE SPEED SETTING.

B. PROGRAMMING VALUES FOR MENU ITEMS

To make a program change to the top heat, bottom heat, or conveyor speed, you must first be in the menu item you want changed. Example: to change the programmed conveyor speed for bagels, the display must read **BAGEL**. To change the programmed conveyor speed for TOAST, the display must read **TOAST** and so on for each menu item.

- 1) Select the menu item you want to change i.e. **TOAST, MUFFIN, BAGEL** or **OTHER**.
- 2) Press and hold both (+) AND (-) buttons for 3 seconds until the display goes blank, release the buttons and the display will show three characters for the menu item elected and the last two characters for the current value setting, i.e. **TST, MUF, BGL** and **OTH**. The red L.E.D. light for top heat at the bottom of the label will flash.
- 3) Press the (+) or (-) buttons to increase or decrease the setting for the top heat.
- 4) Press the button for the menu button again and the red L.E.D. for the bottom heat will flash.
- 5) Press the (+) or (-) buttons to increase or decrease the setting for the bottom heat.
- 6) Press the button for the menu button again and the red L.E.D. for the conveyor speed will flash.
- 7) Press the (+) or (-) buttons to increase or decrease the setting for the conveyor speed.
- 8) To skip one feature setting with out making any changes, press the menu item button one time and the red L.E.D. light for the next item will now flash.
- 9) To change the POWER SAVER values press the SAVER button or to save your new setting(s), and exit the program mode press the menu button.
- 10) The last two characters in the display will show **MN** for minutes.
- 11) The first three characters will be numerical to represent the time setting.
- 12) Press the (+) or (-) buttons to increase or decrease the setting for the savor mode time. The minimum value is **15** minutes to maximum value of **480** minutes.
- 13) Press the SAVER button to change the power reduction using the (+) or (-) buttons to increase or decrease the setting.
- 14) Press the POWER SAVER button to save changes and to exit.

QCS

QCS_e

CLEANING

Preventive maintenance for your Holman toaster consists of the following recommended cleaning procedures. To keep your toaster in its top operating condition, these steps should be performed on a daily or weekly as indicated.

- A. Clean air intake on bottom of unit.
- B. For lightly soiled conveyor belts, turn conveyor speed control to fastest setting (100) and wipe with a damp cloth (daily) For heavily soiled conveyors, turn conveyor speed control to fastest setting and wipe with a light abrasive pad (as needed).
- C. Turn main power saver switch to the OFF position. Disconnect unit from power source.
- D. After the unit cools, remove interior crumb tray (as shown below) and clean. Slide crumb tray back into position.
- E. Wipe exterior surface of unit.

DO NOT IMMERSE OR LET THE UNIT STAND IN WATER.

DO NOT HOSE DOWN THE UNIT OR THE TABLE/COUNTER IF THE UNIT IS ON THE TABLE/COUNTER.

KEEP AWAY FROM RUNNING WATER.



WARNING

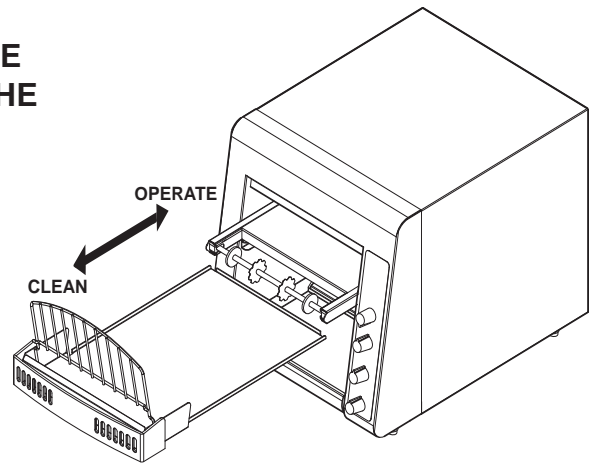

CRUMB TRAY REMOVAL

MAINTENANCE PROCEDURES

A. REPLACING HEATER TUBES

- 1) **DISCONNECT UNIT FROM POWER SOURCE.**
- 2) Remove the enclosure.
- 3) Remove heater tube wire from terminal block connection, keeping top and bottom wires separate.
- 4) Lift heater tube retainers by loosening retaining screws and sliding the retainer plate up. Hand tighten the plate to hold it up so the heater tubes will slide out freely.
- 5) Gently, pull defective heater tube out of unit.
- 6) Gently, put new heater tube into unit.
- 7) Loosen retainer screws and slide the retainer back into place. Tighten the screw to secure the retainer in place over the ends of the heater tubes.

B. REPLACING FAN MOTOR

- 1) **DISCONNECT UNIT FROM POWER SOURCE.**
- 2) Remove screws from the enclosure and the back panel at rear of unit.
- 3) Remove the enclosure and the back panel.
- 4) Unplug power supply cord from fan motor.
- 5) Remove (4) screws, which hold fan motor and grill to bottom of unit and remove fan.
- 6) Put replacement motor and grill in place and secure to the bottom of unit with screws.
- 7) Reconnect power supply cord to fan motor.
- 8) Replace back panel and enclosure. Fasten with screws removed in step 2.

C. REPLACING BELT DRIVE MOTOR

- 1) **DISCONNECT UNIT FROM POWER SOURCE.**
- 2) Remove enclosure and back panel.
- 3) Remove sprocket from motor shaft, using an Allen wrench and loosening the set-screw.
- 4) Remove the wire from terminal block connecting the drive motor to internal wiring.
On units rated 208 or 240 volts, note which color leads are being used for these connections and which lead is capped with white tape. The new motor should use the same arrangement.
- 5) Remove screws holding motor in place and remove motor from unit.
- 6) Put new motor in place and attach loosely with mounting screws.
- 7) Replace sprocket on motor shaft.

NOTE: The two sprockets should line up parallel with each other, so the chain does not twist any during operation. Also the hub gets installed closets to the motor.

- 8) Slide motor until the drive chain has about 1/4" slack when lightly pushed at the center of its top open run. *See chain tensioning illustration.*
- 9) Tighten screws to secure motor.
- 10) Rewire leads same as removed in step 4.
- 11) Replace side panel and control box cover.

D. CLEANING AIR INTAKE ONCE A WEEK

- 1) **DISCONNECT UNIT FROM POWER SOURCE.**
- 2) Place unit on its backside.
- 3) Use a vacuum cleaner and or a damp cloth to clean the air intake. This procedure should be done at least once a week.

E. LUBRICATE THE CHAIN & SPROCKETS EVERY 6 MONTHS

- 1) **DISCONNECT UNIT FROM POWER SOURCE.**
- 2) Remove enclosure exposing chain drive.
- 3) Using an extreme pressure, synthetic chain lubricant with a temperature range up to 400°F. Apply liberally onto chain and sprockets. This grease is available as part no. **1P-Z8914.**
- 4) Replace enclosure, Reconnect power source and test unit.

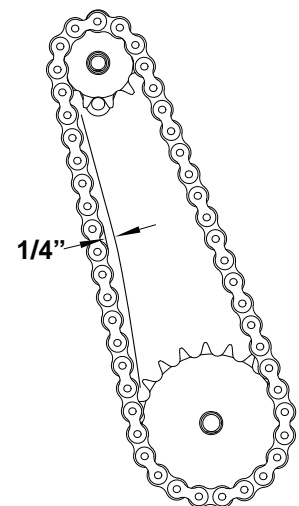

QCS/RCS Chain Tension

TROUBLESHOOTING GUIDE

A. UNIT WILL NOT HEAT, CONVEYOR BELT WILL NOT MOVE.

- 1) Be sure the main circuit breaker is switched to the ON position.
- 2) Check to see if the toaster is plugged in and all controls are turned to the ON position.

B. UNIT HAS HEAT ONLY ON ONE SIDE, CONVEYOR BELT TURNS FREELY.

- 1) Call the Star Service Help Desk at 1-800-807-9054, as heating element may need replacing.

C. CONVEYOR WILL NOT TURN, UNIT HEATS PROPERLY.

To check for mechanical binding:

- 1) **DISCONNECT UNIT FROM POWER SOURCE.**
- 2) Remove 2 screws holding enclosure to the bottom of the unit.
- 3) Set unit on the legs and remove 4 screws on the back of the toaster.
- 4) Slide the enclosure off the unit and remove the back panel.
- 5) Loosen the four screws that hold the drive motor in place.
- 6) Slide the motor up allowing the drive chain to be removed from the sprockets.
- 7) Move the conveyor belt by hand to check for mechanical binding. If conveyor moves freely, call the Star Service Help Desk at 1-800-807-9054, as the drive motor and/or speed control may need replacing.
- 8) Replace the enclosure by sliding it forward towards the front of the unit.
The front edge of the enclosure will slide beneath the toaster front.

D. HEAT LIMIT SWITCH (RESET)

Your Holman conveyor toaster is equipped with an automatically activated heat limit switch that interrupts the heater tube connections if the ambient temperature in the control box exceeds 190°F (88C). This switch can be reset manually by pushing the red button under the toaster as shown in the Toaster Components Illustration on Page 5 & 8.

- 1) **DISCONNECT UNIT FROM POWER SOURCE.**
- 2) Check to see if air intake area in the bottom center of the control box cover is free of dust, grease or other obstructions.
- 3) Check if crumb tray is in place. **NEVER OPERATE UNIT WITHOUT CRUMB TRAY IN PLACE AS THIS CAUSES OVERHEATING IN THE CONTROL BOX.**
- 4) If no obstructions to the airflow can be found and if the crumb tray is in place, call the Star Service Help Desk at 1-800-807-9054 for assistance.

E. CONVEYOR TURNS AT ONE SPEED REGARDLESS OF SPEED CONTROL SETTING.

- 1) Call the Star Service Help Desk at 1-800-807-9054, as speed control should be replaced.

F. PRODUCT STICKING TO CONVEYOR OR SLIDE

Your Holman conveyor toaster is designed to toast product that is at current room temperature. **DO NOT** attempt to put frozen, refrigerated, or any butter or a butter substitute material in the toaster. Doing so may cause it to come out doughy or very moist, as well as possibly sticking to parts of the unit.

- 1) Follow the cleaning procedures listed on page 10.

Visit our Website at: www.star-mfg.com

Email: service@star-mfg.com

THOROUGHLY INSPECT YOUR UNIT ON ARRIVAL

This unit has been tested for proper operation before leaving our plant to insure delivery of your unit in perfect condition. However, there are instances in which the unit may be damaged in transit. In the event you discover any type of damage to your product upon receipt, you must immediately contact the transportation company who delivered the item to you and initiate your claim with same. If this procedure is not followed, it may affect the warranty status of the unit.

LIMITED EQUIPMENT WARRANTY

All workmanship and material in Star products have a one (1) year limited warranty on parts & labor in the United States and Canada. Such warranty is limited to the original purchaser only and shall be effective from the date the equipment is placed in service. Star's obligation under this warranty is limited to the repair of defects without charge, by the factory authorized service agency or one of its sub-agencies. Models that are considered portable (*see below*) should be taken to the closest Star service agency, transportation prepaid.

- > Star will not assume any responsibility for loss of revenue.
- > On all shipments outside the United States and Canada, see International Warranty.
- * The warranty period for the JetStar six (6) ounce & Super JetStar eight (8) ounce series popcorn machines is two (2) years.
- * The warranty period for the Chrome-Max Griddles is five (5) years on the griddle surface. See detailed warranty provided with unit.
- * The warranty period for Teflon/Dura-Tec coatings is one year under normal use and reasonable care. This warranty does not apply if damage occurs to Teflon/Dura-Tec coatings from improper cleaning, maintenance, use of metallic utensils, or abrasive cleaners, abrasive pads, product identifiers and point-of-sale attachments, or any other non-food object that comes in continuous contact with the roller coating. This warranty does not apply to the "non-stick" properties of such materials.
- > This warranty does not apply to "Special Products" but to regular catalog items only. Star's warranty on "Special Products" is six (6) months on parts and ninety (90) days on labor.
- > This warranty does not apply to any item that is disassembled or tampered with for any purpose other than repair by a Star Authorized Service Center or the Service Center's sub-agency.
- > This warranty does not apply if damage occurs from improper installation, misuse, wrong voltage, wrong gas or operated contrary to the Installation and Operating instructions.
- > This warranty is not valid on Conveyor Ovens *unless* a "start-up/check-out" has been performed by a Factory Authorized Technician.

PARTS WARRANTY

Parts that are sold to repair out of warranty equipment are warranted for ninety (90) days. The part only is warranted. Labor to replace the part is chargeable to the customer.

SERVICES NOT COVERED BY WARRANTY

1. Travel time and mileage rendered beyond the 50 mile radius limit
2. Mileage and travel time on portable equipment (*see below*)
3. Labor to replace such items that can be replaced easily during a daily cleaning routine, ie; removable kettles on fryers, knobs, grease drawers on griddles, etc.
4. Installation of equipment
5. Damages due to improper installation
6. Damages from abuse or misuse
7. Operated contrary to the Operating and Installation Instructions
8. Cleaning of equipment
9. Seasoning of griddle plates
10. Voltage conversions
11. Gas conversions
12. Pilot light adjustment
13. Miscellaneous adjustments
14. Thermostat calibration and by-pass adjustment
15. Resetting of circuit breakers or safety controls or reset buttons
16. Replacement of bulbs
17. Replacement of fuses
18. Repair of damage created during transit, delivery, & installation OR created by acts of God

PORTABLE EQUIPMENT

Star will not honor service bills that include travel time and mileage charges for servicing any products considered "Portable" including items listed below. These products should be taken to the Service Agency for repair:

- * The Model 510FD Fryer.
- * The Model 526TOA Toaster Oven.
- * The Model J4R, 4 oz. Popcorn Machine.
- * The Model 518CMA & 526CMA Cheese Melter.
- * The Model 12MC & 15MC & 18MCP Hot Food Merchandisers.
- * The Model 12NCPW & 15NCPW Nacho Chip/Popcorn Warmer.
- * All Hot Dog Equipment **except Roller Grills & Drawer Bun Warmers.**
- * All Nacho Cheese Warmers **except Model 11WLA Series Nacho Cheese Warmer.**
- * All Condiment Dispensers **except the Model HPD & SPD Series Dispenser.**
- * All Specialty Food Warmers **except Model 130R, 11RW Series, and 11WSA Series.**
- * All QCS/RCS Series Toasters **except Model QCS3 & RCS3 Series.**
- * All Fast Steamer Models **except Direct Connect Series.**

ALL:

- * Pop-Up Toasters
- * Butter Dispensers
- * Pretzel Merchandisers
(Model 16PD-A Only)
- * Pastry Display Cabinets
- * Nacho Chip Merchandisers
- * Accessories of any kind
- * Sneeze Guards
- * Pizza Ovens
(Model PO12 Only)
- * Heat Lamps
- * Pumps-Manual

The foregoing warranty is in lieu of any and all other warranties expressed or implied and constitutes the entire warranty.

FOR ASSISTANCE

Should you need any assistance regarding the Operation or Maintenance of any Star equipment; write, phone, fax or email our Service Department. In all correspondence mention the Model number and the Serial number of your unit, and the voltage or type of gas you are using.

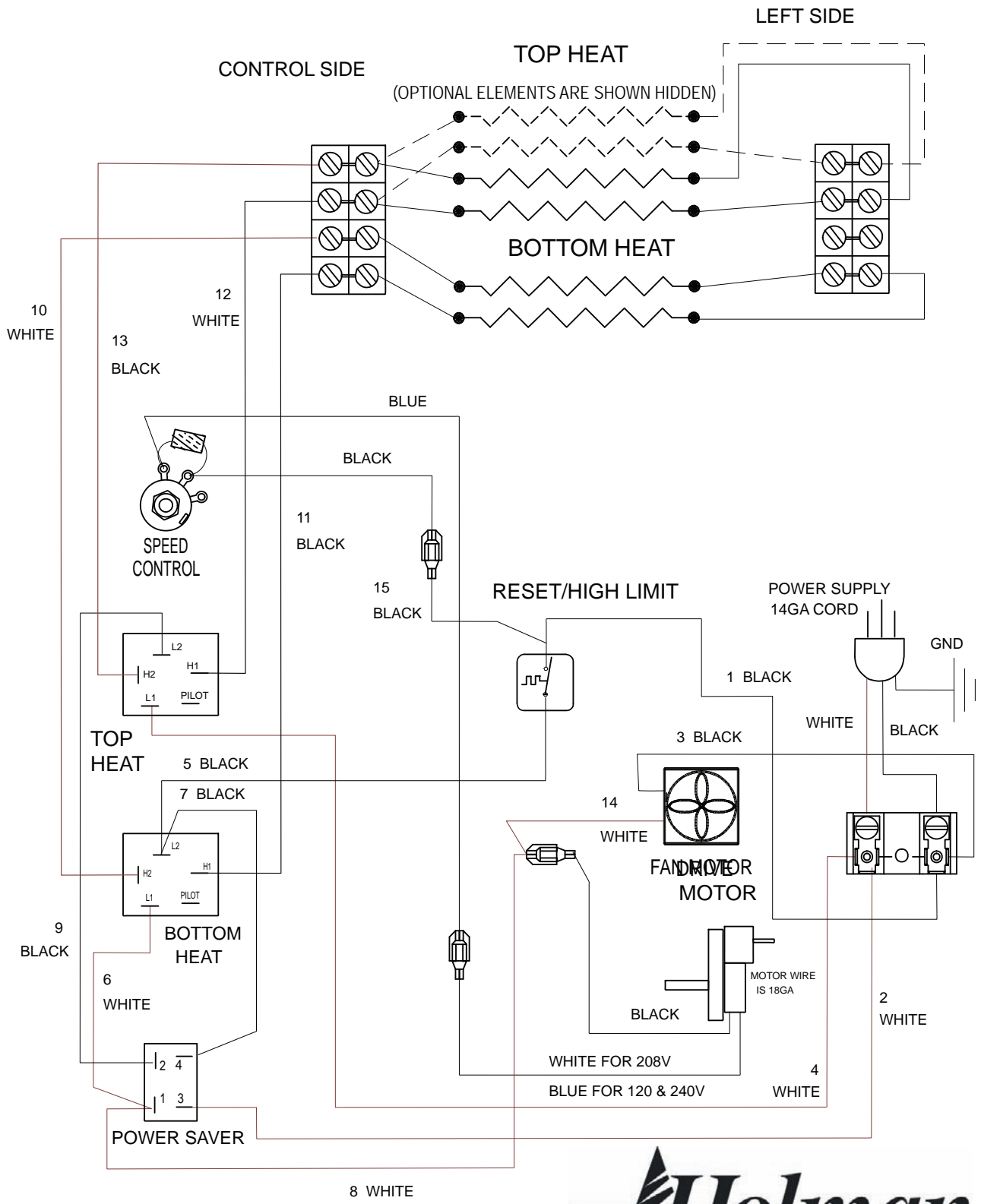

THIS DRAWING CONTAINS INFORMATION CONFIDENTIAL TO STAR MFG. INT'L. INC.
 NO REPRODUCTION OR DISCLOSURE OF ITS CONTENTS IS PERMITTED.

MODEL: QCS2 & 3 Wired Series
 RCS2 & 3 Wired Series



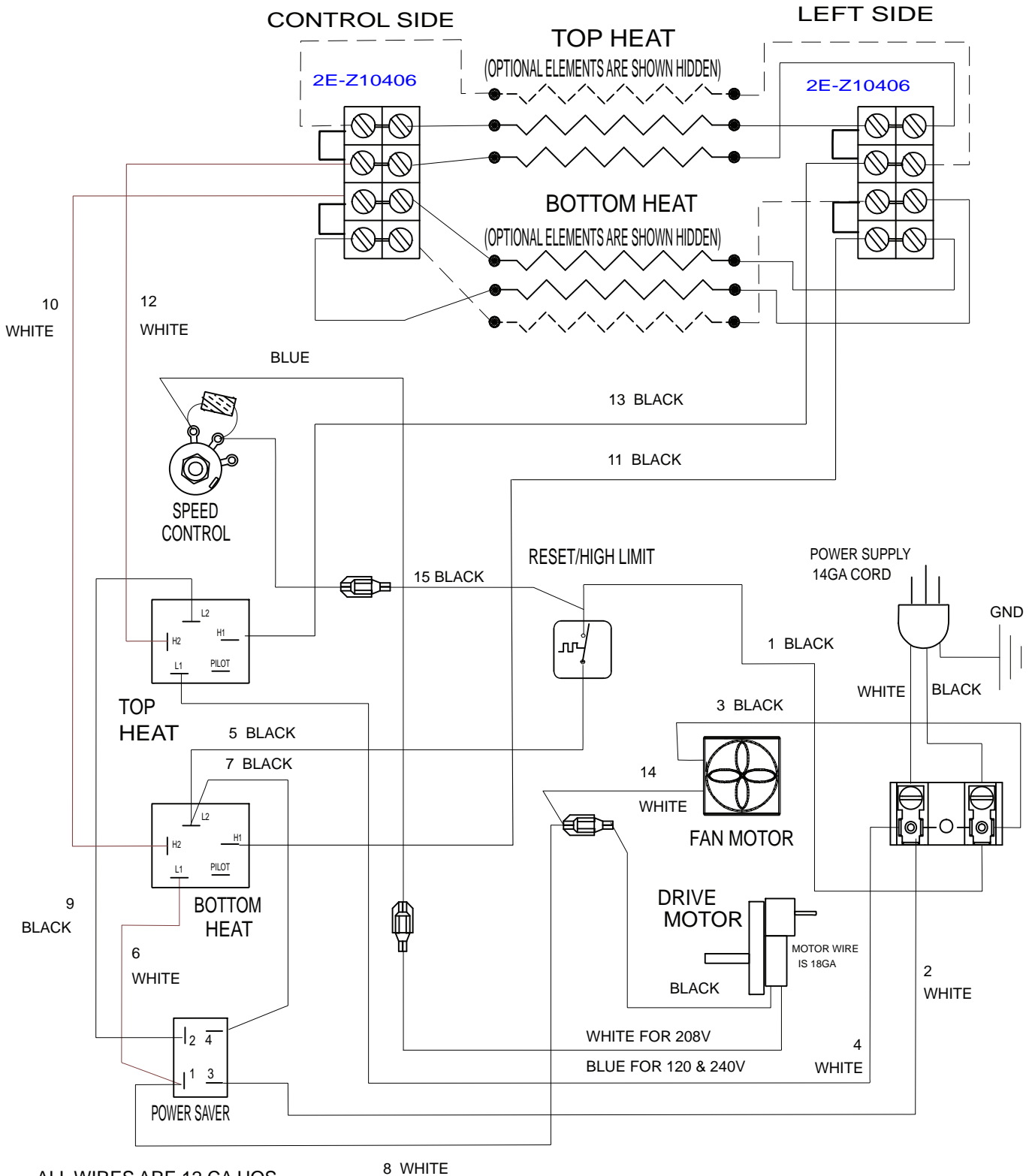

ALL WIRES ARE 12 CA UOS
 1N-E2010 12GA 150C BLACK
 1N-E2011 12GA 150C WHITE

THIS DRAWING CONTAINS INFORMATION CONFIDENTIAL TO STAR MFG. INT'L. INC.
 NO REPRODUCTION OR DISCLOSURE OF ITS CONTENTS IS PERMITTED.

MODEL: QCS2 & 3 Wired Parallel
 RCS2 & 3 Wired Parallel



SK2241 Rev - 7/2007

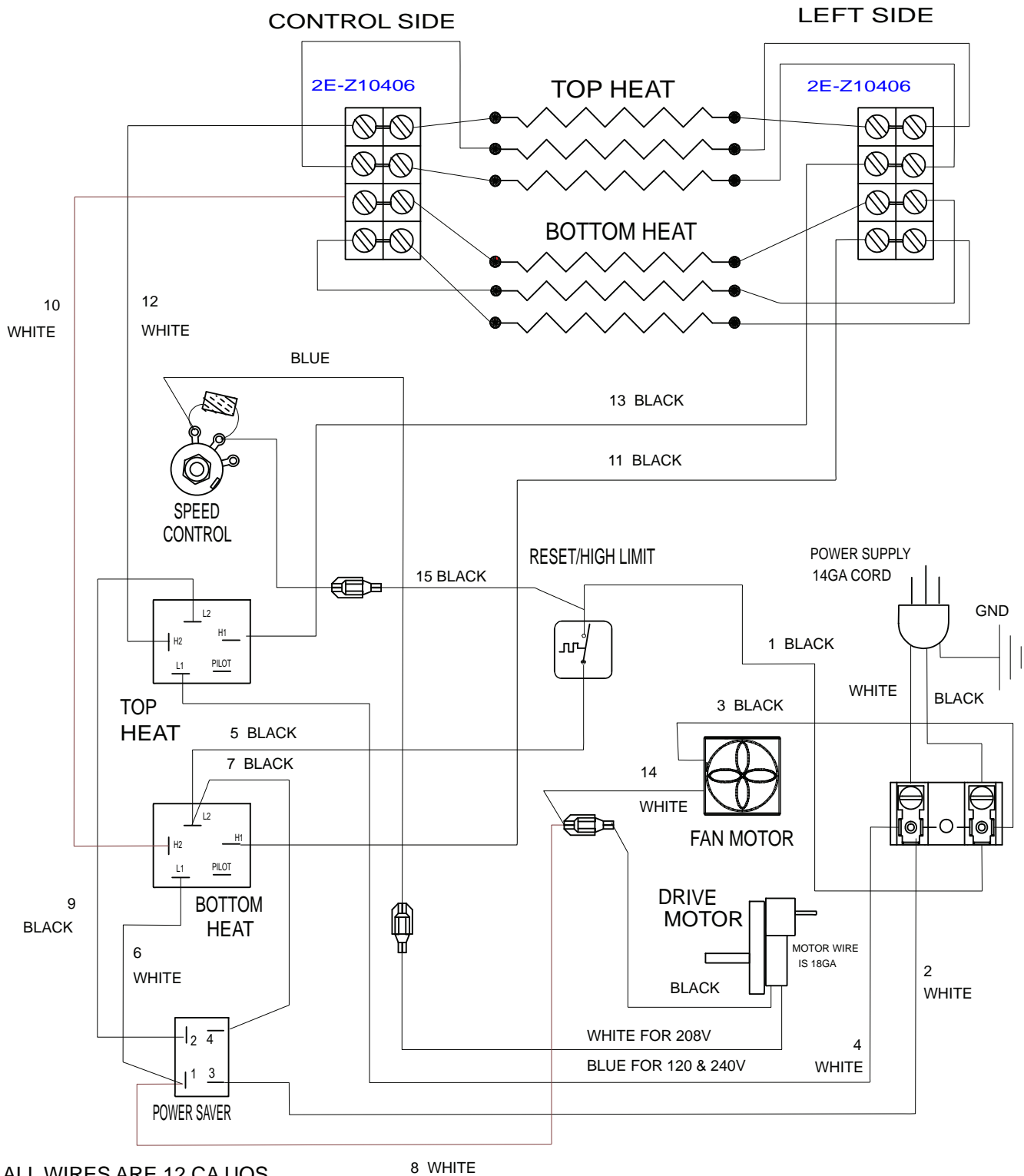

ALL WIRES ARE 12 CA UOS
 1N-E2010 12GA 150C BLACK
 1N-E2011 12GA 150C WHITE
 Ref: SOW# 2E-Z10380

THIS DRAWING CONTAINS INFORMATION CONFIDENTIAL TO STAR MFG. INTL. INC.
 NO REPRODUCTION OR DISCLOSURE OF ITS CONTENTS IS PERMITTED.

MODEL: QCS2 & 3, 3 Wired in Series
 RCS2 & 3, 3 Wired in Series



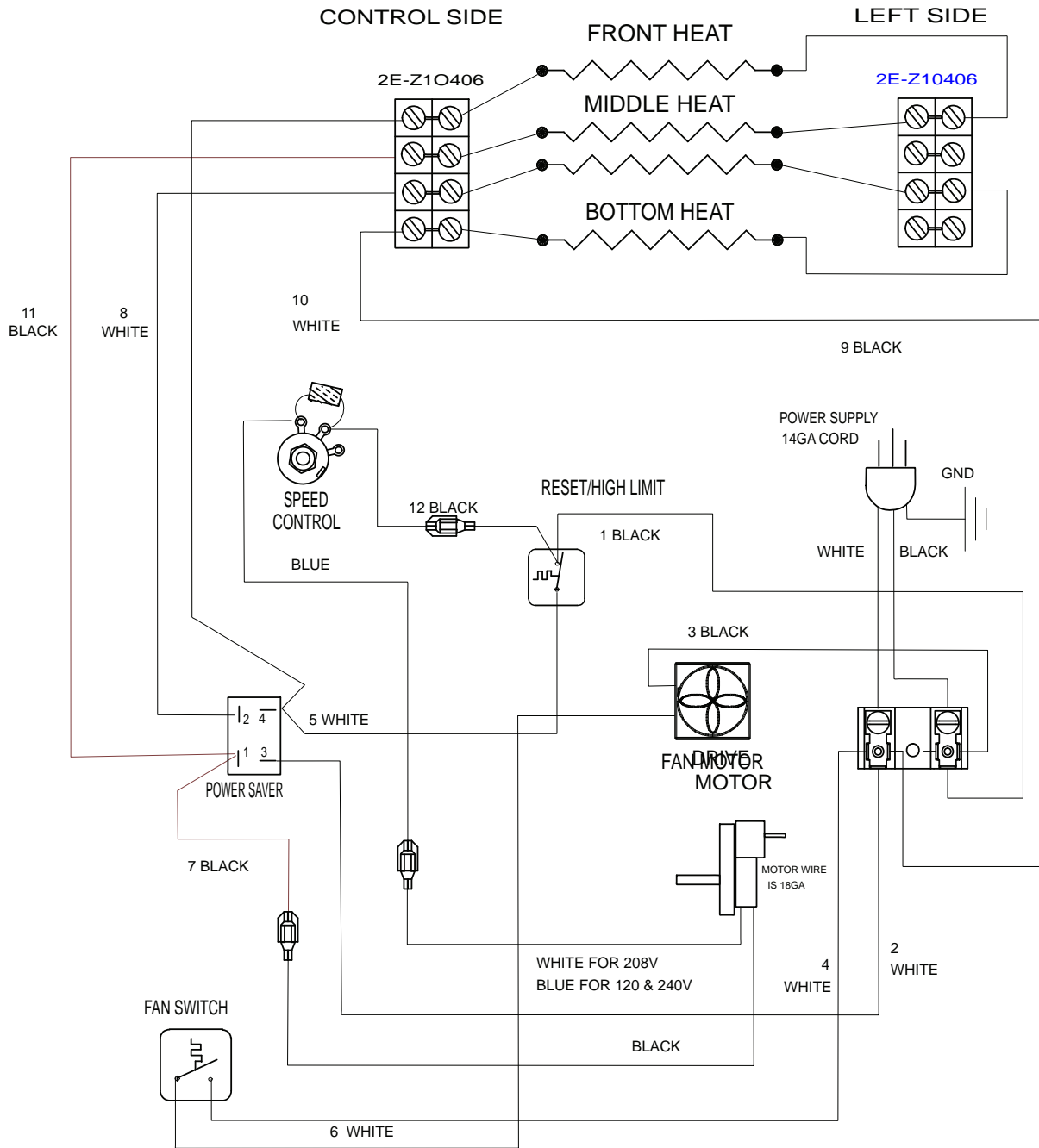

ALL WIRES ARE 14 CA UOS
 1N-E2020 14GA 150C BLACK
 1N-E2021 14GA 150C WHITE

THIS DRAWING CONTAINS INFORMATION CONFIDENTIAL TO STAR MFG. INT'L. INC.
 NO REPRODUCTION OR DISCLOSURE OF ITS CONTENTS IS PERMITTED.

MODEL: QCS2 & w/Fan Switch, Series
 RCS2 & w/Fan Switch, Series



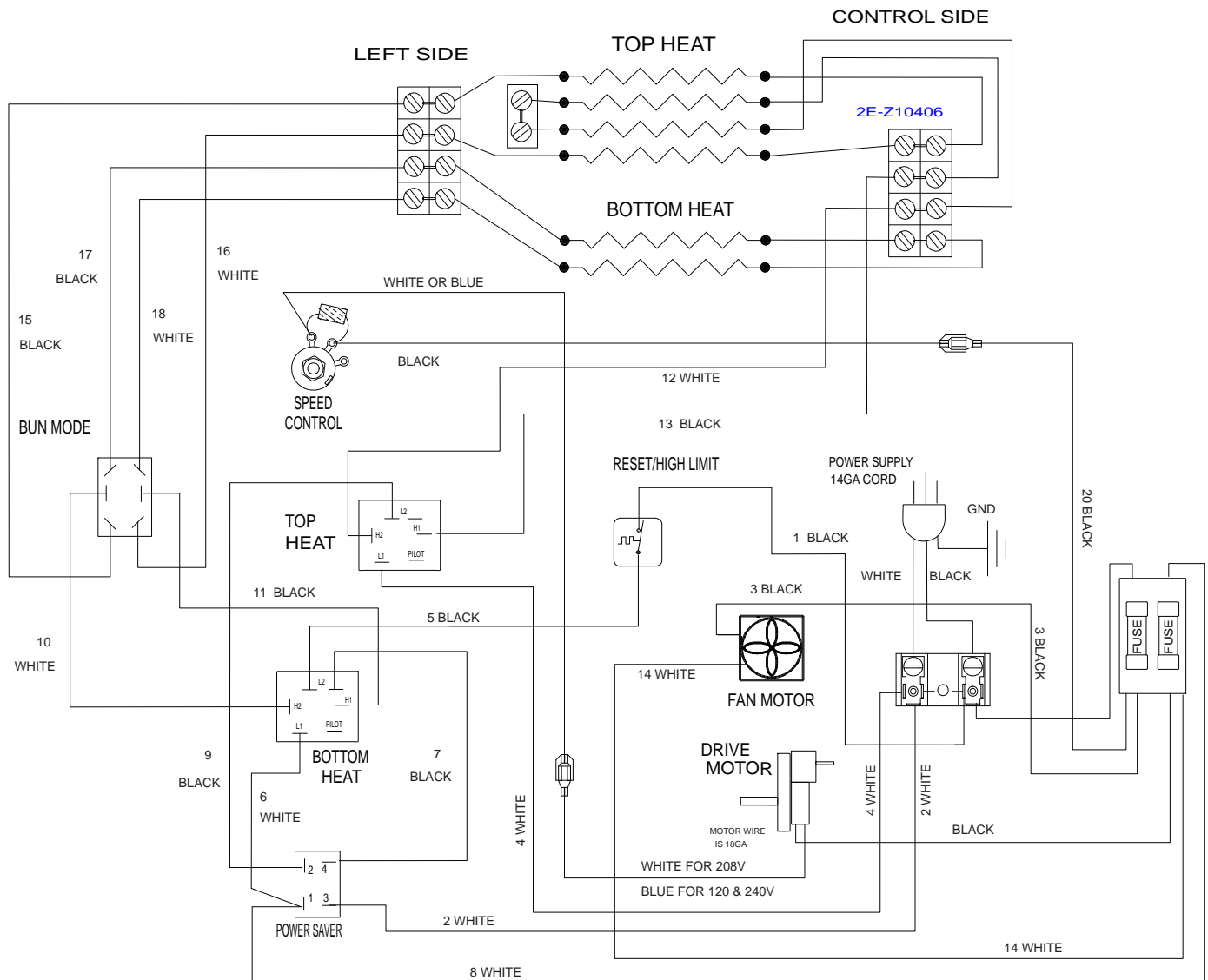

SERIES HEATER TUBES

ALL WIRES ARE 12 CA UOS
 1N-E2010 12GA 150C BLACK
 1N-E2011 12GA 150C WHITE

MODEL: QCS2 & 3, Wired Series w/ Bun Mode & Fuses
 RCS2 & 3 Wired Series w/ Bun Mode & Fuses



THIS DRAWING CONTAINS INFORMATION CONFIDENTIAL TO STAR MFG. INT'L. INC.
 NO REPRODUCTION OR DISCLOSURE OF ITS CONTENTS IS PERMITTED.

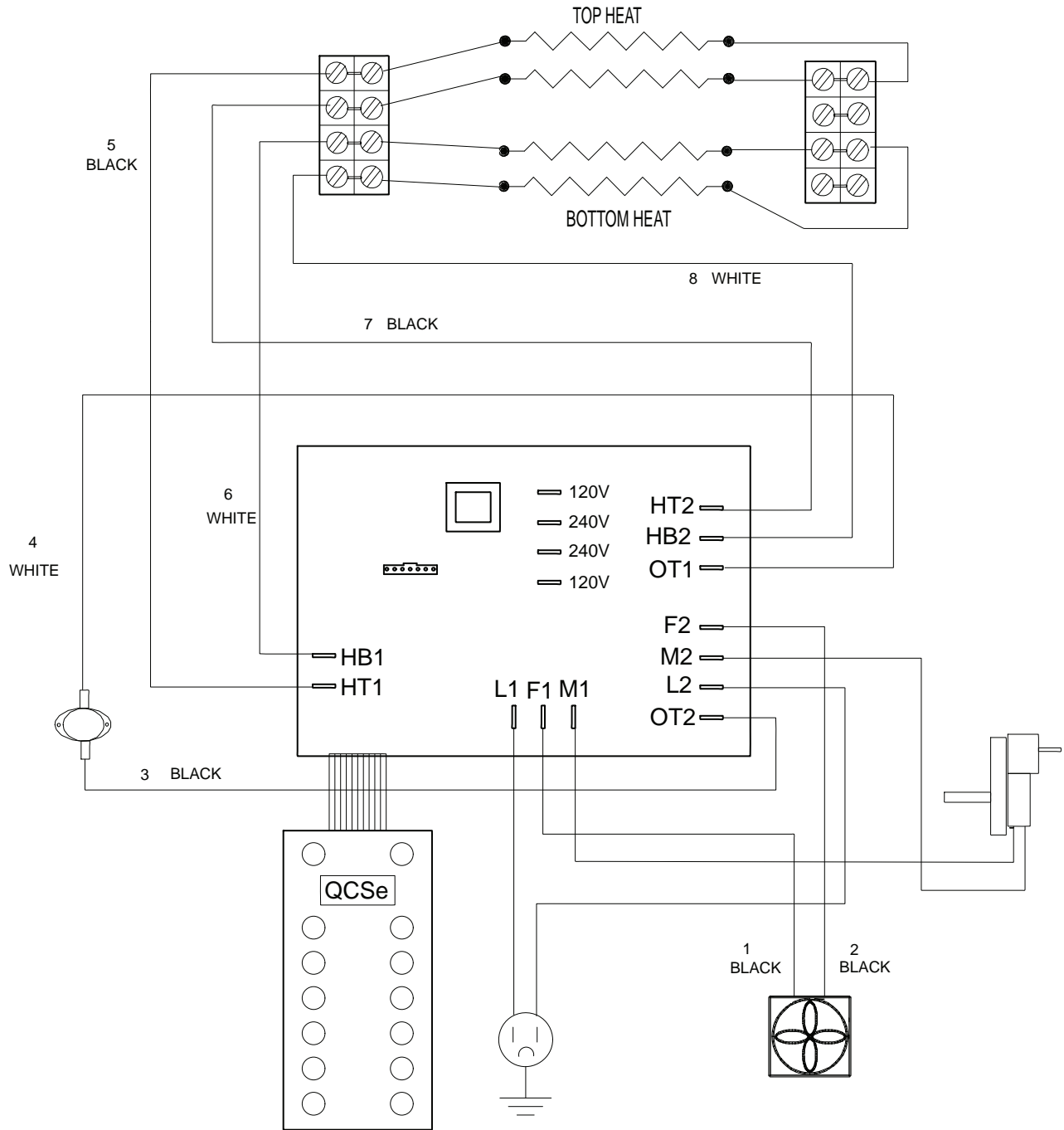

THIS DRAWING CONTAINS INFORMATION CONFIDENTIAL TO STAR MFG. INTL. INC.
NO REPRODUCTION OR DISCLOSURE OF ITS CONTENTS IS PERMITTED.

MODEL: QCSe 4 Tube wired Series



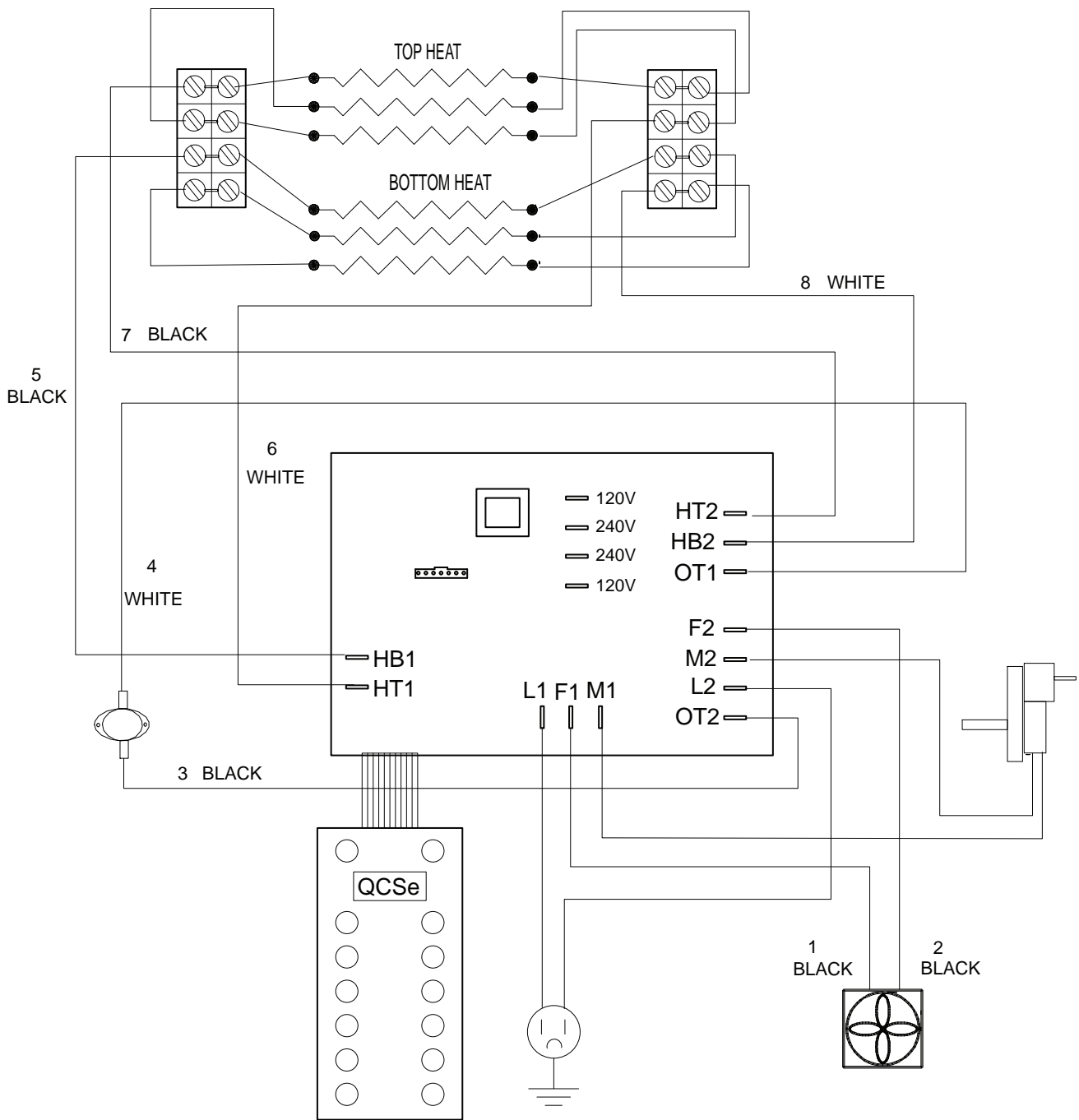

THIS DRAWING CONTAINS INFORMATION CONFIDENTIAL TO STAR MFG. INT'L. INC.
NO REPRODUCTION OR DISCLOSURE OF ITS CONTENTS IS PERMITTED.

MODEL: QCSe 6 Tube wired Series



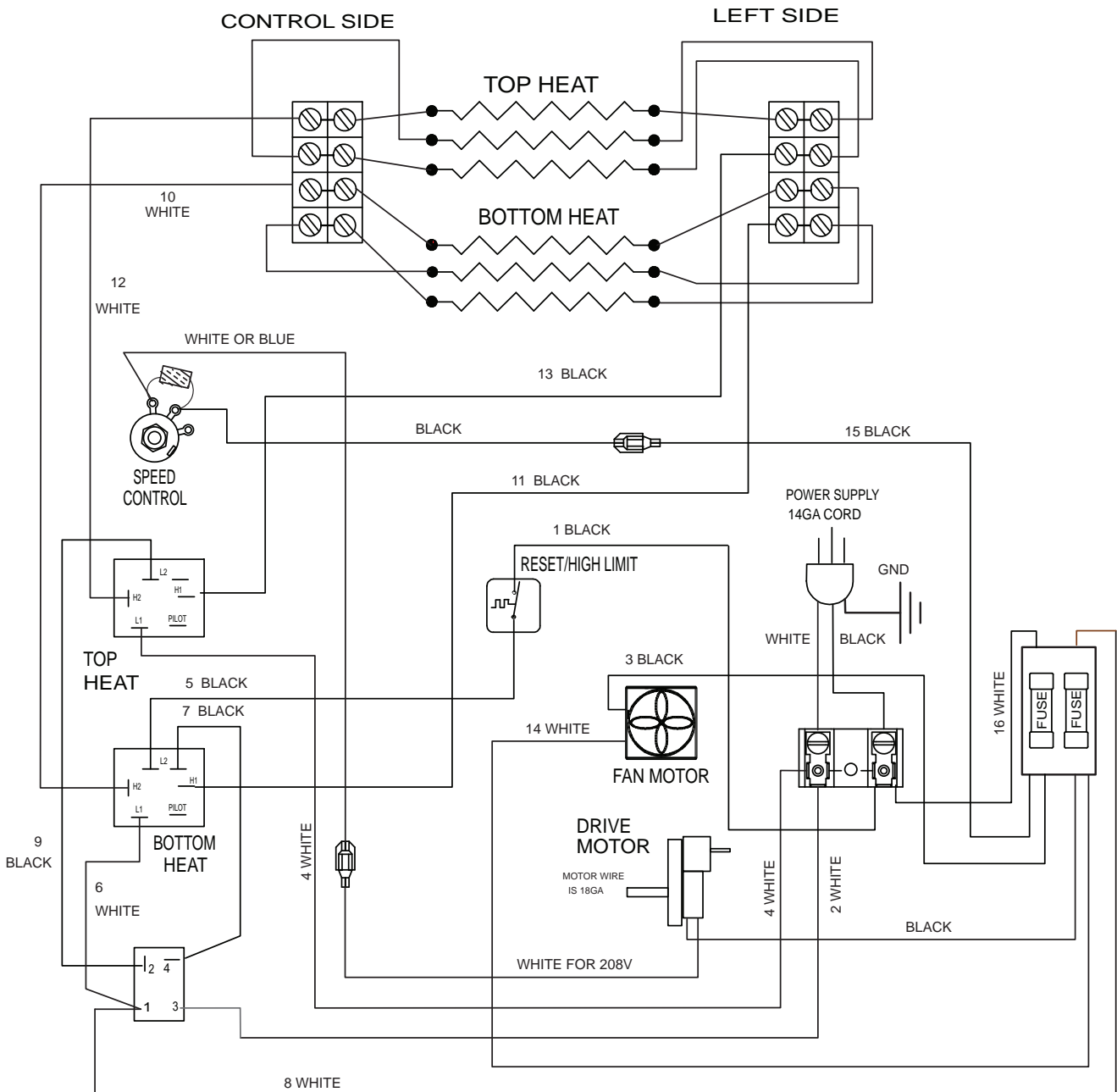

SOME ITEMS ARE INCLUDED FOR ILLUSTRATIVE PURPOSES ONLY AND IN CERTAIN INSTANCES MAY NOT BE AVAILABLE

**QCS-3, 6 ELEMENTS
WIRED SERIES WITH
FUSES**



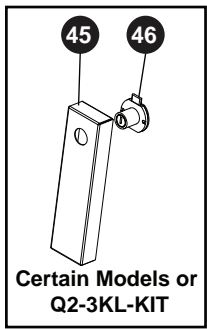
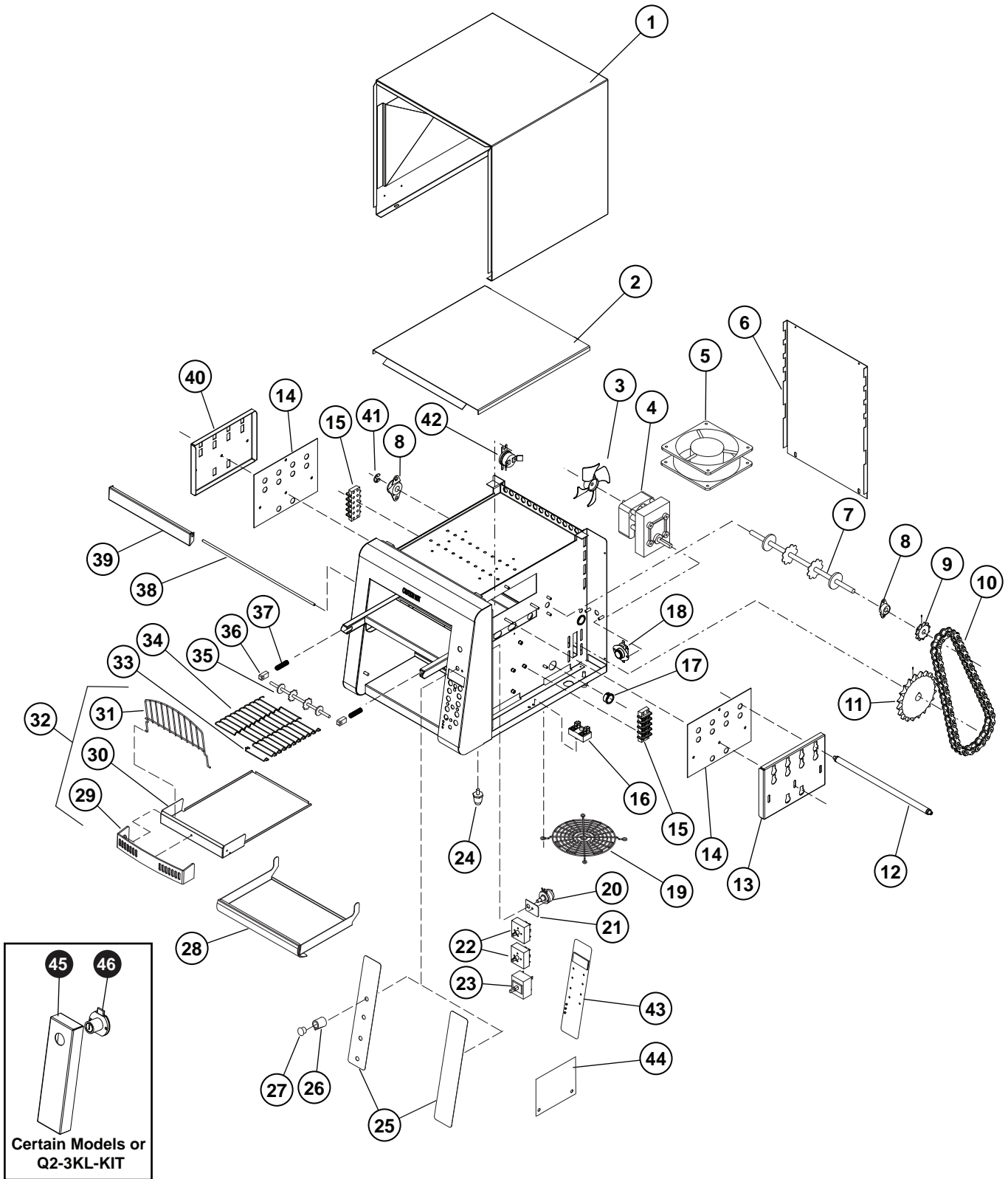

SOME ITEMS ARE INCLUDED FOR ILLUSTRATIVE PURPOSES ONLY AND IN CERTAIN INSTANCES MAY NOT BE AVAILABLE

This drawing contains information confidential to Star Manufacturing International, Inc. No reproduction or disclosure of its contents is permitted.



Model
Q2/Q2E/RCS2/Q3/Q3E Conveyor Toaster

PARTS LIST

June 30, 2011, Rev. D

Models: Q2-500-120V, Q2E-500-120V, Q2-500-CUL20, Q2-600H-CE, Q2-600H-UK, Q2-600HF-208, Q2-600H-208/220/240V, Q2-600HS-208, Q2E-600H-208/240V, Q2-800-208/220/240V, Q2-800-240UK, Q2-800-230CE, Q2E-800-208/240V, Q2-1200B-208/240V, R2-12BSZ-208/240V, R2--1200-208/240V, R2-600HJ-208/240V, R2-800-208V **CONVEYOR TOASTERS**

Fig No	Part No.	Qty	Description	Application
1	HC-120258	1	ENCLOSURE ASSY - QCS-2	ALL
2	HB-120270	1	TOP BAFFLE ASSY QCS-2 LOW	Q2-800-208/220/240V, Q2-1200B-208/240V, R2-12BSZ-208/240V, R2-1200B-208/240V, R2-600HJ-208/240V, Q2-500-120V, Q2-500-CUL20, Q2E-500-120V, Q2E-500CUL20, Q2-800-240UK
	HB-120280		BAFFLE ASSEMBLY, HIGH	Q2-600H-208/220/240V , Q2E-600H-208/240V, Q2E-800-208/240V, Q2-600H-CE
3	2R-Z8879	1	2-5/8" DIA. FAN BLACK CW	ALL
4	HA-120243	1	MTR, ASSY QCS, 220/230/240	Q2-600H-CE, Q2-600H-UK, Q2-800-240UK, Q2-800-230CE
	HB-120240		MOTOR ASSY 120V	Q2-500-120V, Q2-500-CUL20, Q2E-500-120V, Q2E-500CUL20, R2E-500-120V
	HB-120262		MOTOR ASSY 208-240V	Q2-600H-208/220/240V, Q2-800-208/220/240V, Q2-1200B-208/240V, R2-12BSZ-208/240V, R2-1200B-208/240V, R2-600HJ-208/240V, Q2E-600H-208V, Q2-800-240UK, R2E-800-208V
5	2U-200559	1	FAN 120V	Q2E-500-120V, Q2E-500CUL20
	2U-200560		FAN 240V	Q2-600H-208/220/240V, Q2-800-208/220/240V, R2-600HJ-208/240V, Q2E-600H-208V, Q2E-800-208/240V, Q2-500-120V, Q2-500-CUL20, Q2E-500-120V, Q2-600H-CE, Q2-600H-UK, R2E-800-208V
	2U-200561		MOTOR, FAN240V 23BTM	Q2-1200B-208/240V, R2-12BSZ-208/240V, R2-1200B-208/240V, R2E-12BK-208V
6	HC-Z10412	1	BACK PANEL QCS-2	ALL
7	2A-202900	1	SHAFT, T710 DRIVE	ALL
8	HA-112261	2	BEARING ASSY, 5/16 TEFLON	Q2-600H-208/220/240V, Q2-800-208/220/240V, R2-600HJ-208/240V, Q2E-600H-208V, Q2E-800-208/240V, Q2-500-120V, Q2-500-CUL20, Q2E-500-120V, Q2E-500CUL20, Q2-600H-CE, Q2-600H-UK, R2E-800-208V
	HA-112263		BEARING ASSY, PTFE/ BRONZE	Q2-1200B-208/240V, R2-12BSZ-208/240V, R2-1200B-208/240V, R2E-12BK-208V
9	2P-Z8779	1	SPROCKET, 25P-11T .313 ID	ALL
10	2P-150013	1	DRIVE CHAIN #25	Q2-600H-208/220/240V, Q2-800-208/220/240V, R2-600HJ-208/240V, Q2E-600H-208V, Q2E-800-208/240V, Q2-500-120V, Q2-500-CUL20, Q2E-500-120V, Q2E-500CUL20, R2E-800-208V
	2P-150015		CHAIN DRIVE #25	Q2-1200B-208/240V, R2-12BSZ-208/240V, R2-1200B-208/240V, R2E-12BK-208
11	2P-200645	1	SPROCKET, 25B17 X 5/16"	Q2-600H-208/220/240V, Q2-800-208/220/240V, R2-600HJ-208/240V, Q2E-600H-208V, Q2E-800-208/240V, Q2-500-120V, Q2-500-CUL20, Q2E-500-120V, Q2E-500CUL20, Q2-600H-CE, Q2-600H-UK, R2E-800-208V
	2P-200648		SPROCKET, 25B32 X 5/16	Q2-1200B-208/240V, R2-12BSZ-208/240V, R2-1200B-208/240V, R2E-12BK-208

**IMPORTANT: WHEN ORDERING, SPECIFY VOLTAGE OR TYPE GAS DESIRED
INCLUDE MODEL AND SERIAL NUMBER**

PAGE 1
OF 4

Some items are included for illustrative purposes only and in certain instances may not be available.



PARTS LIST

June 30, 2011, Rev. D

Models: Q2-500-120V, Q2E-500-120V, Q2-500-CUL20, Q2-600H-CE, Q2-600H-UK, Q2-600HF-208, Q2-600H-208/220/240V, Q2-600HS-208, Q2E-600H-208/240V, Q2-800-208/220/240V, Q2-800-240UK, Q2-800-230CE, Q2E-800-208/240V, Q2-1200B-208/240V, R2-12BSZ-208/240V, R2--1200-208/240V, R2-600HJ-208/240V, R2-800-208V **CONVEYOR TOASTERS**

Fig No	Part No.	Qty	Description	Application
12	2N-209100	4	ELEMENT, METAL 120V 430W	R2E-500-120V
	2N-209112	2	ELEMENT, SERPENTINE, RCS	R2-12BSZ-240V, R2-1200B-240V
	2N-209114		SERPENTINE ELEMENT RCS	R2-12BSZ-208V, R2-1200B-208V, R2E-12BK-208
	2N-209194		ELEMENT METAL, 200W/120V	R2-12BSZ-240V, R2-1200B-240V
	2N-209198		ELEMENT METAL, 200W/104V	R2-12BSZ-208V, R2-1200B-208V, R2E-12BK-208
	2N-209199		METAL ELEMENT, 500W, 104V	R2-600HJ-208V
	2N-209216	4	ELEMENT, METAL, 500W, 120V	R2-600HJ-240V
	2N-209197		ELEMENT METAL, 700W/104V	R2-800-208V, R2-800H-208V, R2E-800-208V
	HO-197842		HEATERTUBE, QUARTZ	Q2-600H-240V, Q2-800-240V, Q2E-600H-240V, Q2E-600H-240V, Q2-600H-UK, Q2-800-240UK
	HO-197842	6	HEATERTUBE, QUARTZ	Q2-500-120V, Q2E-500-120V, Q2E-500CUL20
	HG-198062	4	HEATERTUBE, QCS-2-1200B	Q2-1200B-208V
	HG-198064		HEATERTUBE, QCS-2-1200B	Q2-1200B-240V
	HO-197841		HEATERTUBE, QUARTZ	Q2-600H-208V, Q2-800-208V, Q2E-600H-208V, Q2E-600H-208V, Q2E-800-208V, Q2-500-120V, Q2-500-CUL20
	HO-197844		HEATERTUBE, QUARTZ	Q2-600H-220V, Q2-800-220V, Q2E-600H-220V, Q2-600H-CE
HC-Z10390	1		ELEMENT RETAINER, RIGHT QCS	Q2-600H-208/220/240V, Q2-800-208/220/240V, Q2E-600H-208V, Q2E-800-208/240V, R2-600H, R2-800
HC-Z10440		ELEMENT RETAINER, RIGHT	Q2-1200B-208/240V	
HC-Z10443		HEATER TUBE RETAINER	R2-12BSZ-208/240V, R2-1200B-208/240V, R2E-12BK-208	
HC-Z11288		1 2	RETAINER, RCS ELEMENT	R2-600H, R2-600HJ R2-800, R2E-500, R2E-800
14	HB-Z10857	2	ELEMENT GUIDE PLATE	Q2-500-120V, Q2-500-CUL20, Q2E-500-120V, Q2E-500CUL20
	HC-Z10388		ELEMENT GUIDE PLATE	Q2-600H-208/220/240V, Q2-800-208/220/240V, Q2E-600H-208V, Q2E-800-208/240V, Q2-600H-CE, Q2-600H-UK, R2-800, R2E-800
	HC-Z10439		ELEMENT GUIDE PLATE 1200	Q2-1200B-208/240V
	HC-Z10442		ELEMENT GUIDE PLATE SERP	R2-12BSZ-208/240V, R2-1200B-208/240V, R2E-12BK-208
15	2E-Z10406	3	TERMINAL BLOCK 4 POS.	R2E-800-208V
		2		Q2E-300H-120, Q2E-500-120V, Q2E-500CUL20, Q2-600H-208/220/240V, Q2-800-208/220/240V, Q2-1200B-208/240V, R2-12BSZ-208/240V, R2-1200B-208/240V, Q2-500-120V, Q2-500-CUL20, Q2E-500-120V, Q2E-500CUL20, Q2-600H-CE, Q2-600H-UK, R2E-500-120V, R2E-12BK-208
		1		Q2E-600H-208/240V, Q2E-800-208/240V
16	2E-Z9736	1	TERMINAL BLOCK - POWER	Q2-600H-208/220/240V, Q2-800-208/220/240V, Q2-1200B-208/240V, R2-12BSZ-208/240V, R2-1200B-208/240V, R2-600HJ-208/240V, Q2E-600H-208V, Q2E-800-208/240, Q2-500-120V, Q2-600H-CE, Q2-600H-UK
17	2K-200464	2	BUSHING WIRE RING 7/8"	Q2-600H-208/220/240V, Q2-800-208/220/240V, Q2E-600H-208V, Q2E-800-208/240V, Q2-500-120V, Q2-500-CUL20, Q2E-500-120V, Q2E-500CUL20, Q2-600H-CE, Q2-600H-UK
		1		Q2-1200B-208/240V, R2-12BSZ-208/240V, R2-1200B-208/240V, R2-600HJ-208/240V
18	2E-200566	1	SWITCH, RESET	ALL

**IMPORTANT: WHEN ORDERING, SPECIFY VOLTAGE OR TYPE GAS DESIRED
INCLUDE MODEL AND SERIAL NUMBER**

PAGE 2
OF 4

Some items are included for illustrative purposes only and in certain instances may not be available.



PARTS LIST

June 30, 2011, Rev. D

Models: Q2-500-120V, Q2E-500-120V, Q2-500-CUL20, Q2-600H-CE, Q2-600H-UK, Q2-600HF-208, Q2-600H-208/220/240V, Q2-600HS-208, Q2E-600H-208/240V, Q2-800-208/220/240V, Q2-800-240UK, Q2-800-230CE, Q2E-800-208/240V, Q2-1200B-208/240V, R2-12BSZ-208/240V, R2--1200-208/240V, R2-600HJ-208/240V, R2-800-208V **CONVEYOR TOASTERS**

Fig No	Part No.	Qty	Description	Application
19	2R-200562	1	FAN GUARD	ALL
20	HA-120239	1	SPEED CONTROL ASSEMBLY	Q2-500-120V, Q2-500-CUL20
	HB-120259		SPEED CONTROL ASSY 250	Q2-1200B-208/240V, R2-12BSZ-208/240V, R2-1200B-208/240V
	HB-120261		SPEED CONTROL ASSY 500	Q2-600H-208/220/240V, Q2-800-208/220/240V, Q2-600H-CE, Q2-600H-UK, R2-600HJ-208/240V, R2-800-208V
21	2P-402728	1	POT, ANTI SPIN PLATE	ALL NON-ELECTRONIC
22	2J-200538	2	SWITCH, EGO 240V INFINITE	Q2-600H-208/220/240V, Q2-800-208/220/240V, Q2-1200B-208/240V, R2-12BSZ-208/240V, R2-1200B-208/240V, R2-600HJ-208/240V, Q2-500-120V,
	2J-200539		SWITCH, EGO 120V INFINITE	Q2-500-120V, Q2-500KL-120, Q2-500-CUL20
23	2E-200551	1	SWITCH ROTARY	Q2-600H-208/220/240V, Q2-800-208/220/240V, Q2-1200B-208/240V, R2-12BSZ-208/240V, R2-1200B-208/240V, R2-600HJ-208/240V, Q2-500-120V, Q2-500-CUL20
24	2R-200709	4	LEG 1" CHOME PLASTIC	Q2-600H-208/220/240V, Q2-800-208/220/240V, Q2-1200B-208/240V, R2-12BSZ-208/240V, R2-1200B-208/240V, R2-600HJ-208/240V, Q2E-600H-208V
25	2M-200864	1	LABEL, QCS-2 & 3 CONTROLS	Q2-600H-208/220/240V, Q2-800-208/220/240V, Q2-500-120V, Q2-500-CUL20, Q2-600H-CE, Q2-600H-UK
	2M-200894		LABEL, QCS-2&3 BAGEL CONT	Q2-1200B-208/240V
	2M-201810		LABEL, RCS-2&3 BAGEL CONT	R2-12BSZ-208/240V, R2-1200B-208/240V, R2-600HJ-208/240V, R2-800-208V
	2M-201813		LABEL, QCSE	Q2E-600H-208V, Q2E-500-120V, Q2E-500CUL20
	2M-Z13358		LABEL - CONTROL Q2E-600HW	Q2E-600HW
	2M-Z13864		LABEL - CONTROL PANEL R2E	R2E-500-120V, R2E-800-208V
	2M-Z14858		LABEL - CONTROL R2E-12BK	R2E-12BK-208
26	2R-200768	1	KNOB, CNTRL Q SERIES, SPEED	Q2-600H-208/220/240V, Q2-800-208/220/240V, Q2-500-120V, Q2-500-CUL20, Q2-600H-CE, Q2-600H-UK
	2R-200769	3	KNOB, POWERSAVER Q SERIES	Q2-600H-208/220/240V, Q2-800-208/220/240V, R2-600HJ-208V, Q2-500-120V, Q2-600H-CE, Q2-600H-UK
		1	KNOB, POWERSAVER Q SERIES	Q2-1200B-208/240V, R2-12BSZ-208/240V, R2-1200B-208/240V, R2-600HJ-208/240V
27	2R-200708	4	KNOB, CONTROL CAP	Q2-600H-208/220/240V, Q2-800-208/220/240V, R2-600HJ-208/240V, Q2-500-120V, Q2-500-CUL20, Q2-600H-CE, Q2-600H-UK
		2	KNOB, CONTROL CAP	R2-12BSZ-208/240V, R2-1200B-208/240V
28	HA-100560	1	TRAY, PULL OUT QCS, 10"	ALL
	HF-100562		SECURITY TRAY, PULL OUT	ALL SECURITY UNITS
29	2R-200787	1	QCS 1&2 CRUMB TRAY GUARD	ALL
30	HC-402457	1	CRUMB TRAY, QCS-2	ALL
	HF-100656		SECURITY CRUMB TRAY, QCS	Q2-600HS-208
	HB-120309		CRUMB TRAY ASSY, Q2E-600HW	Q2E-600HW-208, 240
	HB-120311		CRUMB TRAY ASSY	R2E-12BK-208
31	2B-200763	1	LOADUP, 10 EURO, WIRE	ALL

**IMPORTANT: WHEN ORDERING, SPECIFY VOLTAGE OR TYPE GAS DESIRED
INCLUDE MODEL AND SERIAL NUMBER**

PAGE 3
OF 4

Some items are included for illustrative purposes only and in certain instances may not be available.



PARTS LIST

June 30, 2011, Rev. D

Models: Q2-500-120V, Q2E-500-120V, Q2-500-CUL20, Q2-600H-CE, Q2-600H-UK, Q2-600HF-208, Q2-600H-208/220/240V, Q2-600HS-208, Q2E-600H-208/240V, Q2-800-208/220/240V, Q2-800-240UK, Q2-800-230CE, Q2E-800-208/240V, Q2-1200B-208/240V, R2-12BSZ-208/240V, R2--1200-208/240V, R2-600HJ-208/240V, R2-800-208V **CONVEYOR TOASTERS**

Fig No	Part No.	Qty	Description	Application
32	HF-101115	1	TRAY, CRUMB TRAY ASSY	CERTAIN MODELS
33	2B-Z10675	2	MASTERLINK 10" CONV	ALL
34	SP-160027	1	BELT, CONVEYOR 10"	ALL
35	2A-202904	1	SHAFT, 210HX IDLER	ALL
36	2P-200700	2	SPRING LOAD BEARING TEFLON	ALL
37	2P-200736	2	2" INCH BEARING SPRING	ALL
38	HC-402134	1	NC10H SHUTTER ROD	Q2-600H-208/220/240V, R2-600HJ-208V/240V, Q2E-600H-208V
39	HC-402206	1	HEAT SHUTTER, SWINGING	Q2-600H-208/220/240V, R2-600HJ-208V/240V, Q2E-600H-208V
40	HC-Z10389	1	ELEMENT RETAINER, LEFT QCS	Q2-600H-208/220/240V, Q2-800-208/220/240V, Q2E-600H-208V, Q2E-800-208/240V, Q2-500-120V, Q2-500-CUL20, Q2E-500-120V, Q2E-500CUL20, Q2-600H-CE, R2-600H, R2-800
	HC-Z10441		ELEMENT RETAINER, LEFT QCS	Q2-1200B-208/240V
41	2A-200284	1	E-CLIP 5/16"	ALL
42	2E-200574	1	SWITCH, FAN CERAMIC	Q2-1200B-208/240V, R2-12BSZ-208/240V, R2-1200B-208/240V
43	2U-200591	1	QCSE CONTROL BOARD	Q2E-600H-208/240V, Q2E-800-208/240V, Q2E-500-120V, R2-800-208V, R2E-500-120V
	2E-Z13360		CONTROL BOARD Q2E-600HW	Q2E-600HW
	2E-Z14864		CONTROL BOARD R2E-12BK	R2E-12BK-208
44	2U-200592	1	QCSE POWER BOARD	Q2E-600H-208/240V, Q2E-800-208/240V, Q2E-500-120V
	HD-Z13861	1	POWER BOARD 120V	R2E-500-120V
45	HF-402536	1	SECURITY LOCKING COVER	ALL SECURITY UNITS
46	2R-200752	1	KEYLOCKING SPEC KEYED ALIKE	ALL SECURITY UNITS
	HA-Z11222	1	KEYLOCK - DRILLED	Q2-600HS-208
NI	2K-200463	1	BUSHING CORD HEYCO 1247	Q2-600H-208/220/240V, Q2-800-208/220/240V, R2-600HJ-208V
	2K-200465	1	BUSH CORD HEYCO12/3 BL	Q2-1200B-208/240V, R2-12BSZ-208/240V, R2-1200B-208/240V
	2K-Y2968	1	BUSHING - HEYCO 7W-2	Q2E-600H-208/240V, Q2E-800-208/240V, Q2E-500-120V, R2-800-208V, R2E-500-120V, R2E-12BK-208
NI	2P-200267	1	WIRE BRUSH	R2-1200B-208V
NI	D9-GR0216	1	POWER CORD ASSY-UK	Q2-800-240UK

**IMPORTANT: WHEN ORDERING, SPECIFY VOLTAGE OR TYPE GAS DESIRED
INCLUDE MODEL AND SERIAL NUMBER**

PAGE 4
OF 4

Some items are included for illustrative purposes only and in certain instances may not be available.



PARTS LIST

June 01, 2011, Rev. D

Models: Q3-950H-208/220/240V/CE/UK, Q3-1000-208/220/240/CE/UK, Q3-1300-208/240V, Q3-1400BH-208/240/CE, Q3-1600B-208/240, Q3E-950H-208/240, Q3E-1000-208/240, Q3E-1300-208/240 **CONVEYOR TOASTERS**

Fig No	Part No.	Qty	Description	Application
1	HC-120283	1	CHASSIS ENCLOSURE ASSY	ALL
2	HC-120284	1	ASSY, AIR BAFFLE QCS-3 LO	Q3-950H-208/240
	HC-120285		ASSY, AIR BAFFLE QCS-3 HI	Q3-1400BH
3	2R-Z8879	1	2-5/8 DIA FAN BLACK CW	ALL
4	HA-120243	1	MTR,ASSY,QCS,220,230,240V	Q3-950H-CE, Q3-1000-CE, Q3-1000-UK, Q3-1400BH-CE
	HB-120262		MOTOR ASSY 208-240V	Q3-950H, Q3-1000-208V, Q3-1300-240V, Q3-1400BH208
	HC-120289		MOTOR ASSEMBLY QCS3	Q3-1300-208V
	HI-115071		MOTOR, RMS72, W/TERMINALS	Q3E-1300-208
5	2U-200561	1	MOTOR,FAN240V 23BTM	ALL
6	HC-Z11212	1	BACK PANEL,QCS-3	ALL
7	2A-202902	1	SHAFT, T714 DRIVE	ALL
8	HA-112261	2	BEARING ASSY, 5/16 TEFLON	Q3-950H, Q3-1000
	HA-112263		BEARING ASSY PTFE/BRONZE	Q3-1300, Q3-1400BH,
9	2P-Z8779	1	SPROCKET 25P-11T .313 ID	ALL
10	2P-150013	1	DRIVE CHAIN #25 ROLLER	Q3-950H-208/220/240V, Q3-1000-208V
11	2P-200645	1	SPROCKET, 25B17 X 5/16	Q3-950H, Q3-1000, Q3-1400BH
	2P-200648		SPROCKET, 25B32 X 5/16	Q3-1600B
12	GB-197847	4	HEATERTUBE, QUARTZ, 240V	Q3-950H-240V, Q3-1000-240V, Q3E-950H-240V, Q3E-1000-240V
	HL-197862		HEATERTUBE, QCS-3-1600B	Q3-1600B-208
	HL-197863		HEATERTUBE, QUARTZ	Q3-1600B-240
	HT-197845		HEATERTUBE, QUARTZ, 208V	Q3-950H-208V, Q3-1000-208V, Q3E-1000-208V, Q3E-950H-208V
	HT-197846		HEATERTUBE, QUARTZ, 220V	Q3-950H-220V, Q3-950H-CE, Q3-1000-220V, Q3-1000-CE, Q3-1000-UK
	2N-209130		ELEMENT, METAL 208V 800W	R3-950H-208V, R3-1000-208V
	2N-209160		ELEMENT, METAL 240V 800W	R3-950H-CE
	GB-197847		HEATERTUBE, QUARTZ, 240V	Q3-1400BH240
	HJ-198054		HEATERTUBE, QCS-3-1300	Q3-1300-240V, Q3E-1300-240V
	HJ-198060		HEATERTUBE, QCS-3-1300	Q3-1300-208V, Q3E-1300-208V
13	HC-Z10390	1	ELEMENT RETAINER,RHT,QCS-	Q3-950H, Q3-1000, Q3E-950H, Q3E-1000, Q3E-1300
	HC-Z11287	1	ELEMENT REATINER-RH, RCS-2	R3-950H-208V, R3-950H-CE
	HC-Z11288	2	RETAINER, RCS, ELEMENT	R3-1000-208V, R3-950H-208V, R3-950H-CE
14	HC-Z10440	2	ELEMENT RETAINER, RIGHT	Q3-1400BH, Q3-1600B
	HB-Z10858		ELEMENT GUIDE PLATE QCS2	Q3-950H
	HC-Z10388		ELEMENT GUIDE PLATE	Q3-1000, Q3-1300, Q3E-1000, Q3E-950H-208
	HC-Z10439		ELEMENT GUIDE PLATE 1200	Q3-1400BH, Q3-1600B
15	2E-Z10406	2	TERMINAL BLOCK 4 POS	Q3-950H, Q3-1000, Q3-1600B,
16	2E-Z9736	1	TERMINAL BLOCK - POWER	Q3-950H, Q3-1600B,
		2		Q3-1000
17	2K-200464	1	BUSHING, WIRE RING 7/8"	Q3-1400BH
		2		Q3-950H, Q3-1000
18	2E-200566	1	SWITCH, RESET, 0796	ALL
19	2R-200562	1	FAN GUARD	ALL

**IMPORTANT: WHEN ORDERING, SPECIFY VOLTAGE OR TYPE GAS DESIRED
INCLUDE MODEL AND SERIAL NUMBER**

PAGE 1
OF 3

Some items are included for illustrative purposes only and in certain instances may not be available.



PARTS LIST

June 01, 2011, Rev. D

Models: Q3-950H-208/220/240V/CE/UK, Q3-1000-208/220/240/CE/UK, Q3-1300-208/240V, Q3-1400BH-208/240/CE, Q3-1600B-208/240, Q3E-950H-208/240, Q3E-1000-208/240, Q3E-1300-208/240 **CONVEYOR TOASTERS**

Fig No	Part No.	Qty	Description	Application
20	HB-120261	1	SPEED CONTROL ASSY 500	Q3-950H, Q3-1000, Q3-1300-240V, Q3-1600B
	HC-120278		SPEED CONTROL ASSEMBLY	Q3-1300-208V, Q3-1400BH
21	2P-402728	1	POT, ANTI SPIN PLATE	ALL
22	2J-200538	2	SWITCH, EGO 240V INFINITE	Q3-950H, Q3-1000, Q3-1300, Q3-1400BH
23	2E-200551	1	SWITCH ROTARY	ALL
24	2R-200709	4	LEG 1 INCH CHROME PLASTIC	Q3-950H, Q3-1000, Q3-1300, Q3-1400BG, Q3-1600B
	HP-402209		BRACKET, SECURITY LEG TT	Q3-950HS-208
25	2M-200864	1	LABEL, QCS-2 & 3 CONTROL	Q3-950H, Q3-1000, Q3-1300, Q3-1400BG, Q3-1600B
	2M-201813		LABEL, QCSE	Q3E-950H, Q3E-1000, Q3E-1300
	2M-200899		LABEL, RCS-2, RCS-3 CONTR	R3-950H, R3-1000
26	2R-200768	1	KNOB, CONTROL Q SERIES	Q3-950H, Q3-1000, Q3-1300, Q3-1400BH, Q3-1600B
	2R-200769	1	KNOB, POWERSAVER Q SERIES	Q3-1600B
		3	KNOB, POWERSAVER Q SERIES	Q3-950H, Q3-1000, Q3-1300, Q3-1400BH
27	2R-200708	2	KNOB, CONTROL CAP	Q3-1600B
		4		Q3-950H, Q3-1000, Q3-1300, Q3-1400BH
28	HH-100561	1	TRAY, PULL OUT, QCS, 14	ALL
	HI-100563		SECURITY PULL OUT TRAY	Q3-950HS-208
29	2R-200788	1	QCS-3 CRUMB TRAY GUARD	ALL
30	HC-Z11261	1	CRUMB TRAY,QCS3	Q3-950H, Q3-1000, Q3-1300, Q3-1400BG, Q3-1600B
	HI-100566		SECURITY CRUMB TRAY, QCS	Q3-950HS-208, Q3-1300S-208/240
31	2B-200764	1	LOADUP, 14 EURO, WIRE	ALL
32	HI-101116	1	TRAY, CRUMB ASSEMBLY	Q3-950H, Q3-1000, Q3-1300, Q3-1400BG, Q3-1600B
33	2B-200603	3	BELT LINK 14IN SPACECLIP	ALL
34	SP-160028	1	CONVEYOR BELT (14" X 35")	ALL
35	2A-202905	1	SHAFT, 214HX IDLER	ALL
36	2P-200700	2	BEARING-PTFE SPRING LOAD	ALL
37	2P-200736	2	2 INCH BEARING SPRING	ALL
38	HH-402135	1	NC14H SHUTTER ROD	Q3-950H, Q3-1400BH, Q3E-950H
39	HH-401698	1	HEAT SHUTTER, SWINGING	Q3-950H, Q3-1400BH
40	HC-Z10389	1	ELEMENT RETAINER,LFT,QCS-	Q3-950H, Q3-1000, Q3-1300, Q3E-950H, Q3E-1000, Q3E-1300
	HC-Z11288	2	RETAINER, RCS, ELEMENT	R3-950H
	HC-Z10441	1	ELEMENT RETAINER, LEFT	Q3-1400BH, Q3-1600B
41	2A-200284	1	E-CLIP 5/16	ALL
42	2E-200574	1	SWITCH, FAN, CERAMIC	Q3-1600B
	2U-200591		QCSE CONTROL BOARD	Q3E
43	HC-Z13815	1	CONTROL - PROGRAMMED	Q3E-950HP208
	2U-200592		QCSE POWER BOARD	Q3E
44	2U-200592	1	QCSE POWER BOARD	Q3E
45	HB-Z11456	1	SECURITY LOCKING COVER	Q3-950HS-208, Q3-1300S-208/240, 9H-Q2-3KL-KIT
46	2R-200752	1	KEYLOCKING SPEC KEYED ALIKE	Q3-950HS-208, Q3-1300S-208/240, 9H-Q2-3KL-KIT
NI	2E-Z5680	2	FUSE, 5A - CLASS G	Q3-1300-208V, Q3-1400BH
NI	2E-Z5680	4	FUSE, 5A - CLASS G	Q3E-1300-208/240V
NI	2E-Z5681	1	FUSEHOLDER, CLASS G	Q3-1300-208V, Q3-1400BH
NI	2E-Z5681	2	FUSEHOLDER, CLASS G	Q3E-1300-208/240V
NI	2K-200465	1	BUSHING,CORD HEYCO12/3 BL	Q3-950H, Q3-1400BH208

**IMPORTANT: WHEN ORDERING, SPECIFY VOLTAGE OR TYPE GAS DESIRED
INCLUDE MODEL AND SERIAL NUMBER**

PAGE 2
OF 3

Some items are included for illustrative purposes only and in certain instances may not be available.



PARTS LIST

June 01, 2011, Rev. D

Models: Q3-950H-208/220/240V/CE/UK, Q3-1000-208/220/240/CE/UK, Q3-1300-208/240V, Q3-1400BH-208/240/CE, Q3-1600B-208/240, Q3E-950H-208/240, Q3E-1000-208/240, Q3E-1300-208/240 **CONVEYOR TOASTERS**

Fig No	Part No.	Qty	Description	Application
NI	2K-Y2968	1	BUSHING - HEYCO	Q3-950H-CE, Q3-1400BH-CE
NI	2P-200267	1	WIRE BRUSH	
NI	HB-120269	1	CORD ASSY 6-20P W/3 #10R	Q3-950H-208/220/240V
NI	HB-120272	1	ASSY, CORD SET, 6-30P	Q3-1300-208V, Q3-1400BH208, Q3-1600B-208
NI	HB-120276	1	CORD ASSEMBLY CEE7-7	Q3-950H-CE, Q3-1000-CE, Q3-1400BH-CE
NI	HG-402144	1	FAN SWITCH BRACKET	Q3-1600B

**IMPORTANT: WHEN ORDERING, SPECIFY VOLTAGE OR TYPE GAS DESIRED
INCLUDE MODEL AND SERIAL NUMBER**

PAGE 3
OF 3

Some items are included for illustrative purposes only and in certain instances may not be available.

