

QBD® Cooling Systems

31 BRAMSTEELE ROAD
BRAMPTON, ONTARIO
L6W 3K6

TEL: (905) 459-0709
FAX: (905) 459-1478

COOLER : CD40-HC
84-7040-XXX

Exploded View : CD40-HC

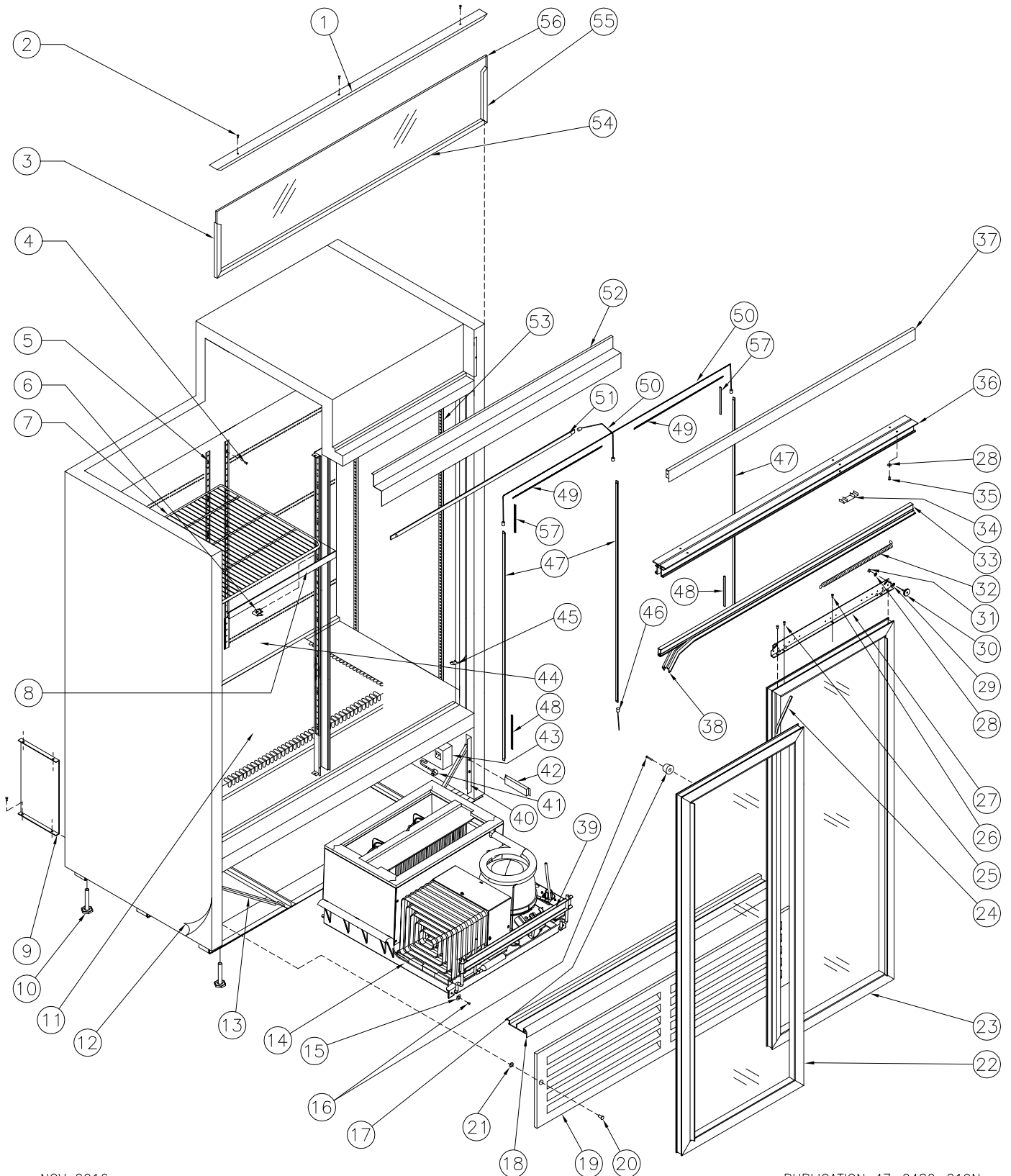



Cooling Systems Inc.

31 Bramstele Rd
Brampton, Ontario, Canada
L6W 3K6

Telephone: (905) 459-0709
Toll Free: (800) 663-3005
FAX: (905) 459-1478
info@qbd.com
www.qbd.com

CD40-HC Cooler

(84-7040-XXX) 120V, 60 Hz.

Item No.	Part No.	Pepsi Part No.	Description	Item No.	Part No.	Pepsi Part No.	Description
1	47-8832-039		Cover, CD40 Top Sign	30	47-0530-088	69715	Wheel Sliding Door 1" Dia ¼ - 20
2	53-0301-021		SCW SM 8 x ½ AB PH TR HD	31	47-0360-036	1006115	Nut ¼ - 20 Hex 2 Way Lock Zinc
3	47-8607-039	1001716	Frame, DC45 LH Top Sign	32	53-0149-076	82310	Spring Door DC40/49
4	47-0400-007	510282	SCW, Pilaster Strip "Custom"	33	47-7393-239	1008150	Seal Holder Door DC40
5	47-0034-420		Pilaster Strip 51" Aluminum	34	47-7386-039	67589	Extrusion Track Filler .875
6	53-0377-032	510362	Bracket (clip) Shelf Support	35	47-0264-308	83973	SCW MA ¼ - 20 x ¾ PAN HD Quad
7	47-0200-193	1009988	Shelf Standard CD40	36	47-0031-570		Track Door 43" LG DC40
8a	47-0130-587		Price Holder CD40/41 20" Black	37	47-8829-039		Cover, CD40 Wheel Black
8b	47-0130-610		Price Holder CD40/41 20" Blue	38	47-7359-139	1006617	Seal Foam Door Horiz 96"
9	47-0034-415		Support CD Brace	39	47-0033-410	1007047	Bracket, CD ½ - ½ HP Lift Rod Lock
10	47-0530-089	510204	Level Leg ½ x 3 x 1.375 AF	40	47-0034-093	1008884	Support CD Grill
11	47-8148-932	1001787	Decal, DC45 Side Pepsi	41	18-7218-001	1007217	Cord, Power 14/3 SJTW-A 12'
12	47-0035-103	1022158	Duct, CD Large Air	42	47-0440-007	1003097	Outlet, 3 Wire
13	-----		Not Applicable On CD40	43	47-0440-087		Driver, LED 20W
14	80-0011-207	1027022	Ref. Chassis ½ HP CD HC R290	44	47-0034-506		Panel, CD40/41 Back Discharge
15	20-0468-012		SCW SM 8 X ¾ PH TR HD	45	47-7379-139	1008528	Gasket Foam Vert. Cabinet 53" LG
16	18-6147-002		Washer 5/16 Bolt Size 7/8" OD	46	47-0450-285		Connector, 36" Wire Lead
17	47-0120-075	1024709	Bumper, Rubber Stopper #RB-186	47	47-0530-672	1027018	LED, 47.5" L11 - 47.5 Series
18	47-8093-239		Bottom, CD40 Guide	48	47-0130-786		Cap, CD45-HC Bottom LED
19	47-8828-039		Grill, CD40 Front Black	49	47-0130-803		Channel, CD40 Wireway
20	47-0254-007		SCW MA 10 x 32 x ¾ PH PAN HD	50	47-0450-312		Connector, CD45/47 Wire Lead
21	47-0530-639		Nut, Push Faster	51	47-0530-671	1027017	LED, 35.5" L11 - 35.5 Series
22	47-7652-739		Door Assy. CD40 LH	52	47-0035-457		Reflector, CD40-HC Top Sign
23	47-7651-739	1024146	Door Assy. CD40 RH	53	53-0377-031	80230	Pilaster Strip 52" Aluminum
24	47-7361-039	69563	Seal Foam Door Vert (5 Ft. Req'd)	54	47-8095-139	1000885	Frame, CD40 Bottom Top Sign
25	47-0400-019		SCW TR 8 - 32 x ½ Slot Hex HD	55	47-8606-039	1002297	Frame, DC45 RH Top Sign
26	53-0301-021		SCW SM 8 x ½ 'AB' PH TR HD	56a	47-8834-633		Lens, CD40/41 White
27	47-0034-124		Bracket, CD40 Door Hanging	56b	47-8834-932		Lens, CD40/41 Pepsi
28	53-0267-006	83974	Washer ¼ Split - Lock Zinc	57	47-0130-785		Cap, CD45-HC Top LED
29	53-0138-013	1006114	Washer ¼ Int-Ext A				

Accessories:

47-0011-307	1024707	Shelf, CD40/41 600ml Gravity
47-0060-178		Gasket Seal UL Ref CD ½ HP
47-0130-441		Shelf Glide CD45 Blue
47-0520-077	81272	Lock & Key Assy Sliding Door
47-0520-216	1001844	Caster Kit - Swivel Type
47-0520-245	1001883	Kit, Casters Transfer - No Wheels
47-0520-273		Kit, Electrics for TPA2414UDS
47-7353-539		Trim, CD/DC Door Handle
47-8092-239		Door Track Bottom CD40
W47-0130-441		Shelf Glide CD45 White

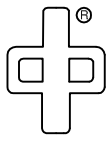

QBD[®] Cooling Systems Inc.

31 BRAMSTEELE ROAD
BRAMPTON, ONTARIO
L6W 3K6

TEL: (905) 459-0709
FAX: (905) 459-1478

REF. CHASSIS 1/2HP PLASTIC BASE
WITH DUAL EVAPORATOR FAN
80-0011-207 120V, 60Hz

**Used in Models:
CD38-HC, CD39-HC,
CD40-HC, CD41-HC,
CD45-HC, CD47-HC**

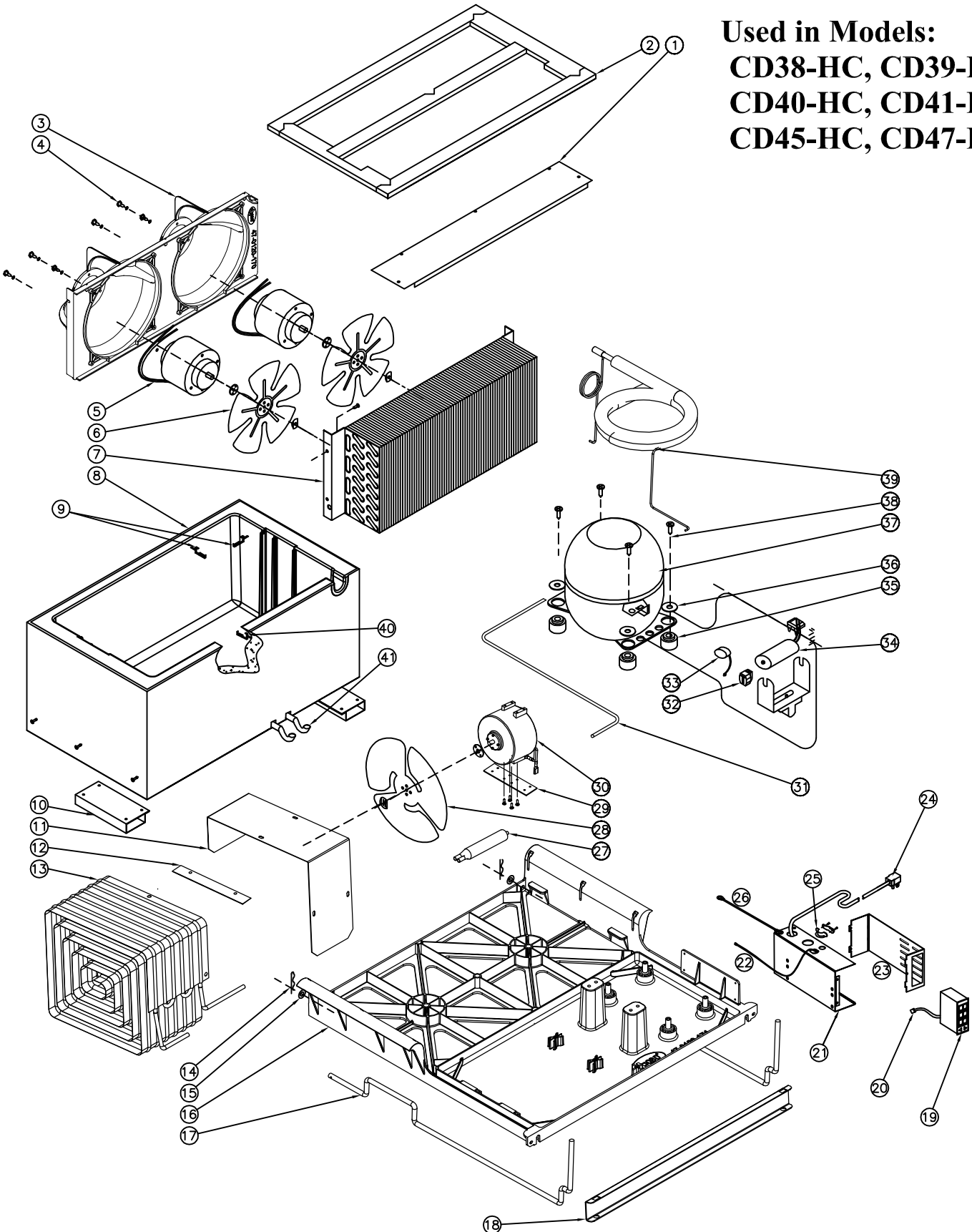



Cooling Systems Inc.

31 Bramsteele Rd
Brampton, Ontario, Canada
L6W 3K6

Telephone: (905) 459-0709
Toll Free: (800) 663-3005
FAX: (905) 459-1478
info@qbd.com
www.qbd.com

Refrigeration Chassis 1/2 HP

80-0011-207 HC R290

120V, 60 Hz.

Item No.	Part No.	Pepsi Part No.	Description	Item No.	Part No.	Pepsi Part No.	Description
1	47-0034-410		Baffle, CD 1/3 - 1/2 HP Evap Air	22	47-0450-281		Harness, CD Compressor
2	47-0060-178		Gasket Seal UL Ref CD 1/2 HP	23	47-0035-463		Cover, HC Chassis Control
3	47-0120-170	1007551	Shroud, 1/2 HP CD, Evap, Plastic	24	47-0450-261		Cord Power 3 Wire 1/4 CD 24"
4	20-0470-002	81343	SCW,ST 8-32x.312" PH PAN HD "F"	25	47-0530-445		Non Metal Sheathed Cable Connector
5a	47-0410-068		Motor, 13W "ECM2" - Electric	26	47-0450-143		Wire, 12" Green #10 Ring - #8 Ring
5b	47-0410-070		Motor, Fan WG-ECM7112	27	47-0011-317		Drier Assy 1/4" Swagged
6	47-0530-541	57910	Fan Blade OP OU7737-5 CW	28	33-2420-001	1003098	Fan Blade 8 3/4 Dia. 3BD CW
7	47-0530-558	1007073	Evap, Coil CD 1/2 HP	29	47-0035-306		Bracket, NR Chassis Condenser Fan
8	47-0011-205		Evap. Box Assy CD 1/3 HP	30a	47-0410-068		Motor, 13W "ECM2" - Electric
9	47-0530-690		Clip Wire	30b	47-0410-070		Motor, Fan WG-ECM7112
10	47-0033-392		Support, CD Rod Rest.	31	47-0100-301		Tube, CD 1/2 - 1/2 HP Discharge
11	47-0034-406		Shroud 1/3 - 1/2 HP CD Condenser	32	47-0430-197		Relay, TPA2414UDS
12	47-0034-360		Bracket, Cond Hold Down	33	47-0430-196		Overload, TPA2414UDS
13	47-0530-547	1006903	Condenser Coil Lint Forgiven	34	47-0430-198		Capacitor, TPA2414UDS
14	47-0530-533		Cotter Pin 3/32" Dia x 1" LG	35	18-9723-000		Grommet (Compressor Foot) 70711
15	18-6147-000		Washer SAE Flat ZC WFS-37	36	18-6147-002		Washer 5/16 Bolt Size - 7/8" OD
16	47-0120-209		Platform, 1/2 HP CD, Comp, Plas Green	37	47-0530-584		Compressor 1/2 HP TPA2414UDS
17	47-0035-285		Rod, CD 1/2 - 1/2 HP Lift - Green	38	47-0400-043		SCW SM #14 - 1/4" L AB PH PAN HD
18	47-0033-410	1007047	Bracket, CD 1/2 HP Lift Rod Lock	39	47-0020-613		Suction Line Assy CD R290
19	47-0430-202		Control, CAREL	40	47-0120-187	640774	Clip, CD Probe
20	47-0430-204		Probe, CAREL	41	47-0120-194		"P" Trap CD Plastic
21	47-0035-462		Box, HC Chassis Control				
				47-0520-255	1020990		Kit, CAREL Cold Control
				47-0520-273			Kit, Electrics for TPA2414UDS