

**FAST FILL CONDIMENT SYSTEMS
MODELS MCD-1FF & MCD-1FFDS**

THIS EQUIPMENT CHAPTER SHOULD BE INSERTED
IN THE EQUIPMENT MANUAL

MANUFACTURED
FOR
McDONALD'S ©
BY
PERFECTION EQUIPMENT, INC.
4259 LEE AVENUE
GURNEE, ILLINOIS 60031
PHONE (847)-244-7200
(800) 356-6301



TABLE OF CONTENTS	
INTRODUCTION	PAGE 2
WARRANTY	PAGE 2
SAFETY	PAGE 2
SYSTEM IDENTIFICATION	PAGE 3-4
PARTS IDENTIFICATION	PAGE 5-8
OPERATING INSTRUCTIONS	PAGE 8-9
TROUBLESHOOTING	PAGE 10-11
ORDERING / SERVICE INFORMATION	PAGE 12
NON-SCHEDULED MAINTENANCE	PAGE 12
BAG CONNECTOR INSTRUCTION	PAGE 13

This manual is for the exclusive use of licensees and employees of McDonald's Systems, Inc.

INTRODUCTION

Models MCD-1FF, and MCD-1FFDS condiment dispense systems manufactured by PERFECTION EQUIPMENT, INC. for McDonald's Corporation, are designed primarily for rapid filling of existing manual back-of-house condiment dispensers or squeeze bottles

- Powered by CO2 gas or compressed air.
- Entirely mechanical operation requiring no electrical connection.
- Improves sanitation.
- Reduces labor costs by maintaining a large quantity of product "on line".
- Easy access to product containers for ease of use and employee comfort

WARRANTY

Manufacturers limited warranty for the condiment dispensing systems, models MCD-1FF and MCD-1FFDS

PERFECTION EQUIPMENT warrants that condiment systems manufactured by us will be free from material and workmanship defects, under normal use and service for a period of one (1) year from the date of original installation. The limited warranty will apply only to condiment systems that were installed by factory approved installers. The limited warranty will not apply to systems or any part thereof where the cleaning and sanitation procedures have not been in accordance with those provided with the equipment.

Any alleged defective part should be returned, freight prepaid to the factory. PERFECTION EQUIPMENT, INC. shall not be liable for any labor, damage or other expense, nor shall PERFECTION EQUIPMENT, INC. be liable for any indirect, incidental or consequential damages of any kind incurred by reason of the use or sale of any defective product or part.

SAFETY

THE CONDIMENT DELIVERY AND DISPENSING SYSTEMS MANUFACTURED BY PERFECTION EQUIPMENT, INC. ARE GENERALLY POWERED BY CARBON DIOXIDE GAS (CO2) PRESSURE. ALTHOUGH THIS IS THE SAME GAS THAT IS USED TO MAKE THE BUBBLES IN CARBONATED BEVERAGES AND IS A NON-POISONOUS GAS THERE IS A DANGER OF AIR REPLACEMENT IN A CONFINED SPACE WHEN CARBON DIOXIDE IS LEAKING.

WHEN CONDIMENT SYSTEMS ARE PRESSURIZED BY BULK CO2 SYSTEMS THE PRESSURE CONTAINED WITHIN THE SYSTEM WILL BE LESS THAN 200 PSI. WHEN TANKS OF CO2 GAS ARE USED TO PRESSURIZE THE CONDIMENT SYSTEM THE PRESSURE IN THE TANK CAN REACH 1000 PSI. CARE SHOULD BE TAKEN TO STORE AND USE THE CYLINDERS OF CO2 GAS SAFELY.

THE HIGH PRESSURE REGULATOR THAT IS ATTACHED TO THE CO2 CYLINDER REDUCES THE PRESSURE OUTPUT TO A LOWER LEVEL, USUALLY 100 PSI. IT IS IMPERATIVE THAT THE TANK'S MAIN VALVE BE SECURELY SHUT OFF WHEN THE TANK IS CHANGED. BE SURE THAT THE NEW TANK'S VALVE NOT BE OPENED UNTIL THE REGULATOR IS SECURELY ATTACHED.

McDonald's

(BACK OF HOUSE)

MODEL MCD-1FF

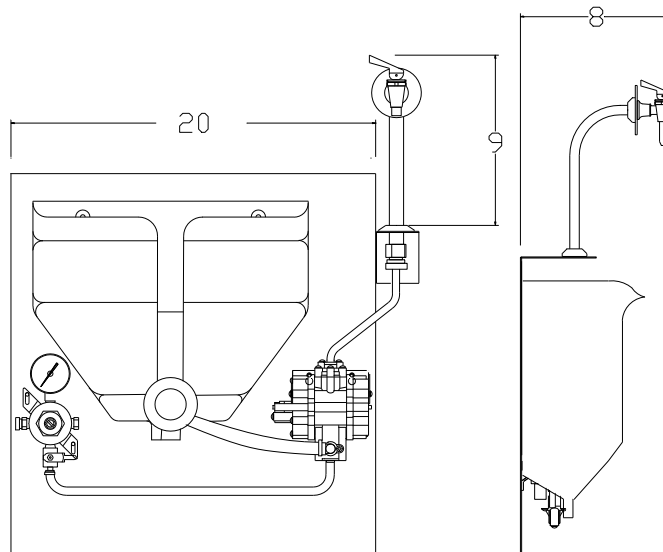

All components fully pre-fabricated on Stainless Steel mounting plate, ready to mount to the wall. System also includes a Clean-In-Place Kit.

Requires connection to a remote CO₂ source.

Optional High-Pressure regulator available when remote CO₂ is not easily accessible.

PERFORMANCE

Product

Packaging

Flow Rate @ 65 PSI

Flow Rate @ 30 PSI

Fill time for Prince Castle Model 406-A Dispenser

Fill time for Prince Castle Model 406-A Dispenser

Ketchup

3-Gallon bag – Volpak

3.2 ounces / second

2.2 ounces / second

15 seconds @ 65 PSI

22 seconds @ 30 PSI



KETCHUP WRIN NUMBER 04843-006

McDonald's

(BACK OF HOUSE)

MODEL MCD-1FFDS

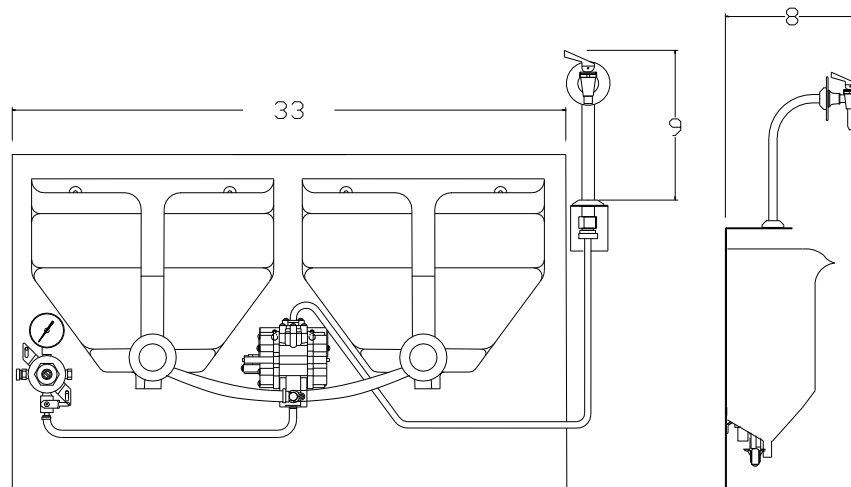

All components fully pre-fabricated on Stainless Steel mounting plate, ready to mount to the wall. System also includes a Clean-In-Place Kit.

Requires connection to a remote CO₂ source.

Optional High-Pressure regulator available when remote CO₂ is not easily accessible.

PERFORMANCE

Product

Packaging

Flow Rate @ 65 PSI

Flow Rate @ 30 PSI

Fill time for Prince Castle Model 406-A Dispenser

Fill time for Prince Castle Model 406-A Dispenser

Ketchup

3-Gallon bag – Volpak

3.2 ounces / second

2.2 ounces / second

15 seconds @ 65 PSI

22 seconds @ 30 PSI



KETCHUP WRIN NUMBER 04843-006

WALL MOUNT PLATE ASSEMBLY

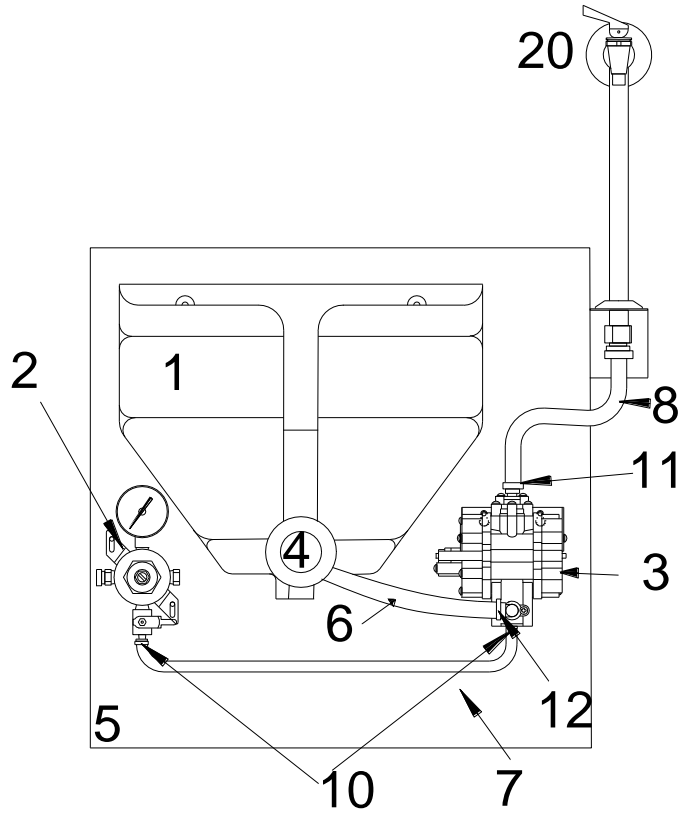
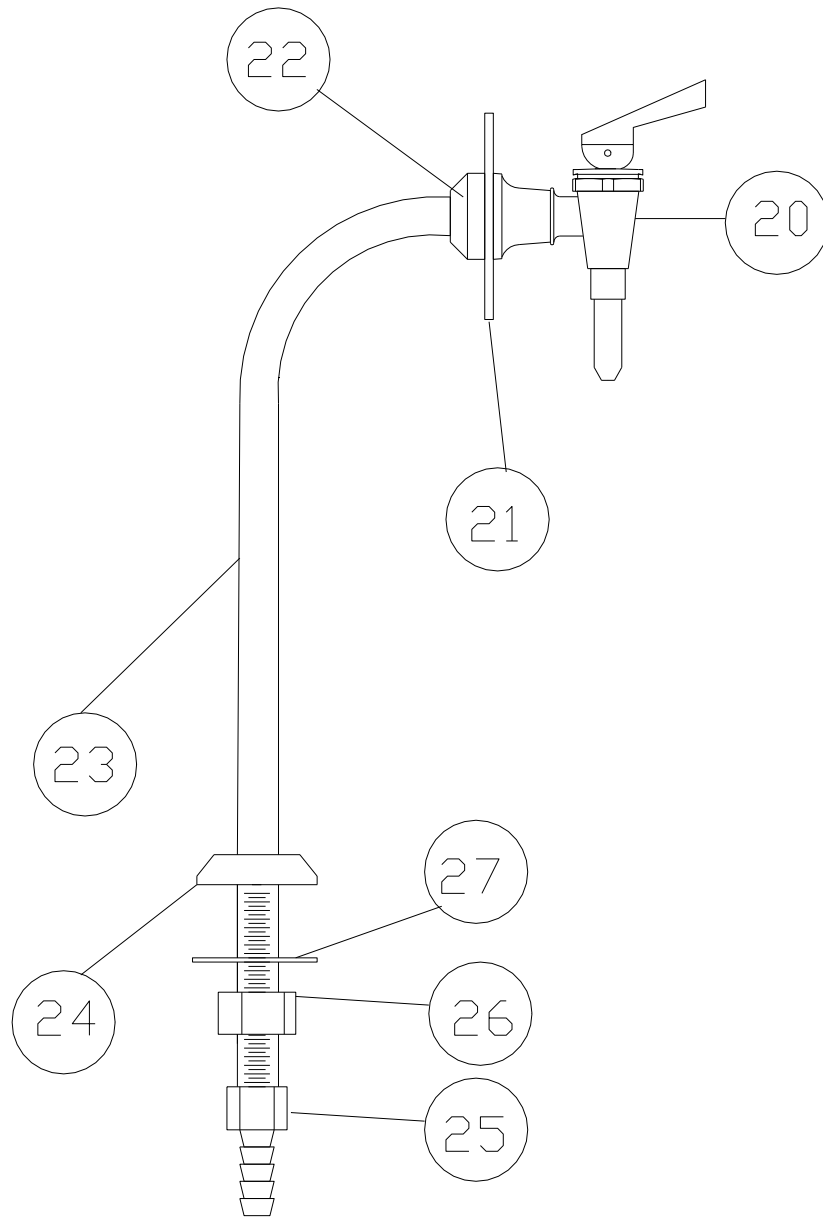

FIGURE 1

FIGURE 2
PT-1
WITH HIGH FLOW SURESHOT VALVE



PARTS IDENTIFICATION

(REFER TO FIGURES #1 +2)

#	PART NUMBER	DESCRIPTION	FUNCTION
1	C04-0025	PLASTIC SADDLE	HOLDS PRODUCT BAG
2	18-5011	LOW PRESSURE REGULATOR	DETERMINES PRODUCT FLOW RATE
3	C00-0010	CONDIMENT PUMP	PULLS PRODUCT FROM BAG AND PRESSURIZES LINE
4	C11-0050	BAG CONNECTOR BODY	CONNECTS BAG TO SYSTEM
	C11-0060	BAG CONNECTOR CAP (SEE #1 PAGE 14)	ATTACHES TO BAG
5	C04-0013	WALL PLATE	
6	C15-0015	CLEAR VINYL TUBE	PRODUCT TUBE – BAG TO PUMP
7	C15-0040	¼" ID BRAIDED TUBE	CO2 GAS TUBE
8	C15-0010	½" ID BRAIDED TUBE	PRODUCT TUBE
10	C09-0095	12.3 TAB CLAMP	SECURES TUBING
11	C09-0098	21.0 TAB CLAMP	SECURES TUBING
12	09-0625	21.0 TAB CLAMP	SECURES TUBING
20	C20-0012	HIGHFLOW SURESHOT VALVE	DISPENSER
21	C03-0030 KETCHUP	PRODUCT LABEL KETCHUP	IDENTIFIES PRODUCT
21	C03-0030 MUSTARD	PRODUCT LABEL MUSTARD	IDENTIFIES PRODUCT

21	C03-0030 BBQ	PRODUCT LABEL BBQ	IDENTIFIES PRODUCT
22	C01-0100	PT-1 UPPER COLLAR	SECURES LABEL AND FAUCET
23	C01-0100	PT-1 COLUMN	BODY OF DISPENSER
24	C01-0100	PT-1 LOWER COLLAR	SECURES BASE OF DISPENSER
25	12-C026	PT-1 FITTING	ATTACHES PRODUCT LINE
26	C01-0100	PT-1 NUT	SECURES BASE OF DISPENSER
27	C01-0100	PT-1 WASHER	SECURES BASE OF DISPENSER

POWERED CONDIMENT DISPENSING™ SYSTEM OPERATING INSTRUCTIONS

NOTE: IF YOU PURCHASED A PERFECTION POWERED CONDIMENT™ SYSTEM WITH PERFECTION'S INSTALLATION OPTION, STEPS 2 THROUGH 4 WILL HAVE BEEN DONE BY OUR INSTALLER AND DEMONSTRATED TO YOUR STAFF.

1. Before hooking up product for the first time after installation, clean the system according to the cleaning instructions supplied.
2. Installing the Condiment Bag and Connector – C.P.C. (See attached instruction sheet PAGE 13)
3. Connecting The High Pressure Regulator (If applicable)
If you are using a CO2 tank rather than remote or centralized CO2, you will need to connect the high-pressure regulator to the tank before using the system. Connect the high pressure regulator to the CO2 tank by inserting the gasket/washer into the connecting nut on the CO2 high pressure regulator and screwing the CO2 connecting nut on the regulator onto the CO2 tank outlet. Tighten the tank nut by turning it clockwise. Open the valve on top of the CO2 tank completely by turning it counter clockwise and check the high pressure gauge which should be set at 100 p.s.i. Note: On single product systems the pressure should first be set to 20 p.s.i. and regulated from there until the desired flow rate is achieved. Turn the adjustment screw “in” (clockwise) to increase the pressure or “out” (counter clockwise) to decrease the pressure. There may be a lock nut that must be loosened to allow this adjustment to be made. Always retighten the lock nut after an adjustment is made to prevent the adjustment screw from turning after the desired pressure is set. The other gauge is for determining how much CO2 is in the tank and has no adjustment.
5. Operating the Pumps
Once the CO2 tank has been turned on, the pumps(s) may start to operate for a short period of time. If a pump continues to run after one or two minutes, there may be a leak in the product connection. Check to make sure that the bag connector is installed correctly on the bag of

condiment and that all hose clamps are tight. If the pumps do not begin to operate first, check the CO2 tank valve to make sure that it is open, then check the individual low pressure regulator for each product to make sure that the red lever below each low pressure regulator is turned to its vertical position parallel to the CO2 line leaving each low pressure regulator. Set the low-pressure regulators to a minimum of 20 p.s.i. Products thicker than ketchup may require pressures of up to 50 or 60 p.s.i. to achieve the desired flow rate. To adjust the flow rate use the same procedure as outlined in step #2 above for adjusting the high-pressure regulator. Be sure to tighten the lock nut after the desired flow rate is achieved.

6. Priming the System

Select a product dispensing valve. Depress the valve lever. While product will not dispense immediately, the product pump for that product will begin to operate. Keep the lever depressed until product starts to be dispensed from the valve. The product may sputter at first until the line is fully primed. Continue to dispense until a smooth, full stream of product begins to appear. Repeat this process for all products on line. If the pumps do not begin to operate, first, check the CO2 tank valve to make sure that it is open, then check the individual low pressure regulator for each product to make sure that the red lever below each low pressure regulator is turned to its vertical position parallel to the CO2 line leaving each low pressure regulator.

Set the low-pressure regulators to a minimum of 20 p.s.i. Products thicker than ketchup may require pressures of up to 50 or 60 p.s.i. to achieve the desired flow rate. To adjust the flow rate use the same procedure as outlined in step #3 for adjusting the high-pressure regulator. Be sure to tighten the lock nut after the desired flow rate is achieved. Make sure that there are no kinks in the product lines or bag connector line(s). Check to see that the correct pump is connected to the proper bag of product. Products thicker than ketchup will take longer to prime than thinner, less viscous products.

TROUBLESHOOTING GUIDE

If your Powered Condiment Dispensing™ System is not functioning properly, check the following:

1. Check your CO2 pressure regulator gauges to insure that the tank is not empty and that the proper pressures are set on the low-pressure regulators.
2. Check the connector; make sure that it is fully engaged.
3. If the CO2 and bag connections are OK, and the pump isn't priming, the problem may be that the pump valves are dry and unable to pull product from the bag. Disengage the bag connector and use the CIP (clean in place) hose to see if water can be pumped through the line. If it can, leave the water in the system lines and engage the connector to the bag. Open the valve and allow the food product to force the water out of the lines until product is flowing smoothly.
4. Cleaning procedures should be performed regularly. If they are not it allows product to dry at the valve or dispensing head and at the bag connector. If this appears to be the case due to lack of cleaning, inspect the valve first. Turn off the CO2 tank and then press the lever or button until all pressure is relieved from the line. Remove the valve by gently turning it counter clockwise, disassemble the valve by twisting the nut cap. Then check for any dried product, film, seeds or anything that appears to clog the valve. Soak valve in sanitizing solution and scrub clean; rinse and re-engage valve to line adapter using Teflon tape to insure that there are no leaks. Turn pressure on, engage connector to the product and press the lever to dispense product.

PROBLEM	PROBABLE CAUSE	CORRECTIVE ACTION
Product does not dispense from one valve	Valve nozzle clogged with dry product	Clean nozzle
	Product bag empty	Replace
	Bag connector not connected	Connect bag connector (See page #13)
	Low pressure regulator shut off	Turn handle on low pressure regulator to the 'on' (in-line) position
	Line kinked	Locate kinked line and straighten

Product does not dispense from all valves	CO ₂ supply empty	Change CO ₂ tank to full one
	Air compressor not functioning	Reconnect to power supply
	High pressure regulator in off position	Turn to on position
Product spits when dispensed	Bag connector not connected properly	Disconnect and reconnect properly
	Inlet fitting 'o' ring on pump damaged	Replace (See page #12 Ordering parts)
	Valve nozzle clogged with dry product	Clean nozzle
Product dispenses too slowly	Low pressure regulator set at too low a pressure	Readjust to a higher pressure (see #6 page 9)
	Low pressure regulator set too high	Readjust to a lower pressure (see #6 page 9)
Pump operates but product does not dispense	Bag connector improperly connected or not connected	Connect properly
	Pump lost prime	Clean system and reconnect
	Inlet fitting 'o' ring on pump damaged	Replace (See page #12 Ordering parts)
Valve will not shut off	Valve spring broken	Replace valve (See page #12 Ordering parts)

If you have any questions, comments or suggestions please feel free to contact the factory at (800) 356-6301.

ORDERING PARTS OR SERVICE

PARTS MAY BE ORDERED BY CONTACTING PERFECTION EQUIPMENT, INC. AT 1-800-356-6301 AND ASKING FOR THE PARTS DEPARTMENT. REQUESTS FOR SERVICE INFORMATION GO TO THE SAME PHONE NUMBER AND ARE DIRECTED TO THE SERVICE DEPARTMENT.

NON-SCHEDULED MAINTENANCE

EVERY EFFORT HAS BEEN MADE BY PERFECTION EQUIPMENT, INC. TO ENSURE THAT NONSCHEDULED MAINTENANCE WILL BE MINIMIZED. AS THESE SYSTEMS ARE MECHANICAL IN NATURE THEY WILL EVENTUALLY REQUIRE SERVICE OTHER THAN STANDARD CLEANING. THE ONE THING THAT CAN BE DONE BY THE OPERATOR TO REDUCE SERVICE REQUIREMENTS IS TO **CLEAN THE SYSTEM ON REGULAR BASIS.**

WHEN SERVICE IS REQUIRED THE ONE QUESTION THAT WILL BE ASKED BY PERFECTION EQUIPMENT'S SERVICE PERSONNEL IS "WHEN WAS THE SYSTEM LAST CLEANED?" UNLESS THERE IS A MAJOR PROBLEM, SUCH AS SEVERED LINES, THE CLEANING PROCEDURE AS OUT LINED IN THE MAINTENANCE REQUIREMENT CARD WILL TAKE CARE OF MANY COMMON PROBLEMS.

SHOULD SERVICE BE REQUIRED CALL THE FACTORY SERVICE DEPARTMENT IF IT IS A WARRANTY PROBLEM (WITHIN ONE YEAR OF INSTALLATION) OR THE LOCAL SERVICE AGENT (AFTER ONE YEAR). IF UNSURE OF YOUR LOCAL SERVICE AGENT CALL THE FACTORY AT 1-800-356-6301 FOR ASSISTANCE.

TO DISCONNECT



1st Push-In Coupler Bottom
 (pull firmly to remove)



2nd Remove Bag from Hopper



3rd Wash Spout Facing ↑ Upright
 Remove Cap



4th Do Not Throw Away Cap

5th Thread Cap onto next full bag

TO CONNECT



1st Remove Seal Cap,
 Thread Cap onto Spout
 (keep spout ↑ upright.)



2nd Remove Bag from Box
 (Place Bag Spout ↓ down
 into hopper.)



3rd Connect Hose with
 Coupler to Cap
 (push firmly together.)

Cleaning: Use a clean, moist towel to cleanse all the outside surfaces of the Condiment Coupler System, making sure to remove all dirtied condiments. Next, wrap the towel around your index finger and swab out the interior of the Coupler and Coupler Cap.

Colder Products Company

1001 Westgate Drive, St. Paul, MN 55114 CALL: 651-645-0091 FAX: 651-645-5404 1-800-444-2474 www.colder.com

MAINTENANCE REQUIREMENT CARD

Planned Maintenance System

Equipment: Condiment Dispensing System. Perfection models MCD-1FF,
MCD-1FFDS

DAILY AND WEEKLY CLEANING PROCEDURE

SUPPLIES:

CLEAN, SANITIZED BUCKETS (2)

CLEAN, SANITIZED TOWELS

SMALL BRUSH

McD[®] SANITIZER

McD[®] ALL PURPOSE SUPER CONCENTRATE

DAILY PROCEDURE:

CLEAN AND SANITIZE EXTERIOR OF DISPENSING NOZZLE BY WIPING WITH A CLEAN, SANITIZED TOWEL THAT HAS BEEN SOAKED IN McD[®] SANITIZER SOLUTION (MIX 1 PAK OF McD[®] SANITIZER IN 2 ½ GAL. OF LUKEWARM WATER). PAY PARTICULAR ATTENTION TO REMOVING ANY DRIED ON FOOD PRODUCT FROM THE TIP OF THE DISPENSING NOZZLE.

WEEKLY PROCEDURE:

1. FILL A CLEAN, SANITIZED BUCKET WITH 2-GALLONS OF HOT McD[®] ALL-PURPOSE SUPER CONCENTRATE SOLUTION AS DRAWN THROUGH THE SINK PROPORTIONER.
2. FILL A SECOND CLEAN, SANITIZED BUCKET WITH A FRESH SOLUTION OF McD[®] SANITIZER SOLUTION (MIX 1 PAK OF McD[®] SANITIZER IN 2 ½ GAL. OF LUKEWARM WATER).
3. DISCONNECT THE PRODUCT BAG FROM THE BAG CONNECTOR. DIP END OF BAG CONNECTOR INTO THE DETERGENT SOLUTION AND BRUSH CLEAN THE CONNECTOR TO REMOVE ANY FOOD SOILS. CONNECT THE PROVIDED CLEAN-IN-PLACE TUBE TO BAG CONNECTOR AND SUBMERGE THE FREE END OF THE TUBE INTO THE DETERGENT SOLUTION.
4. PLACE A CLEAN CONTAINER UNDER THE DISPENSER NOZZLE.
5. FLUSH SYSTEM BY DEPRESSING DISPENSER LEVER AND DISPENSING APPROXIMATELY 1-GALLON OF SOLUTION. ALLOW DETERGENT SOLUTION TO STAND IN SYSTEM FOR 5 MINUTES.
6. AFTER 5 MINUTES, DEPRESS THE DISPENSING LEVER AND FINISH DRAWING THROUGH THE REMAINING AMOUNT OF DETERGENT SOLUTION. WHEN THE BUCKET IS EMPTY, LIFT THE CLEAN-IN-PLACE TUBE AND CONTINUE TO DEPRESS DISPENSER FOR APPROXIMATELY 5 SECONDS. THIS WILL FLUSH THE REMAINING SOLUTION THROUGH THE SYSTEM. DISCARD THE SOLUTION THAT WAS COLLECTED FROM THE DISPENSER.
7. RINSE THE SYSTEM BY REPEATING STEPS 4,5, & 6 USING HOT WATER (120°F - 180°F MAX) IN PLACE OF THE DETERGENT SOLUTION.
8. SANITIZE THE SYSTEM BY REPEATING STEPS 4,5, & 6 USING THE SOLUTION McD[®] SANITIZER IN PLACE OF THE DETERGENT SOLUTION.
9. REMOVE THE CLEAN-IN-PLACE TUBE FROM THE SANITIZER SOLUTION BUCKET AND DISCONNECT IT FROM THE BAG CONNECTOR. **NOTE:** IN ORDER TO COMPLETELY CLEAN AND SANITIZE THE INTERIOR OF FEED TUBE AND DISPENSER NOZZLE, YOU MUST DRAW THE FULL 2-GALLONS OF DETERGENT SOLUTION AND SANITIZER THROUGH THE SYSTEM.
10. RECONNECT PRODUCT BAG TO BAG CONNECTOR.
11. FLUSH ANY REMAINING SANITIZER SOLUTION BY DEPRESSING DISPENSING LEVER UNTIL FRESH CONDIMENT IS BEING DISPENSED. **NOTE:** THE CONDIMENT SHOULD NOT APPEAR WATERY OR THIN
12. DISPENSE AT LEAST 6 PORTIONS OF CONDIMENT TO THOROUGHLY FLUSH OUT ANY REMAINING SANITIZING SOLUTION.