

# Service Manual

# Pitco Frialator



for the

# TURBOFRY 2000

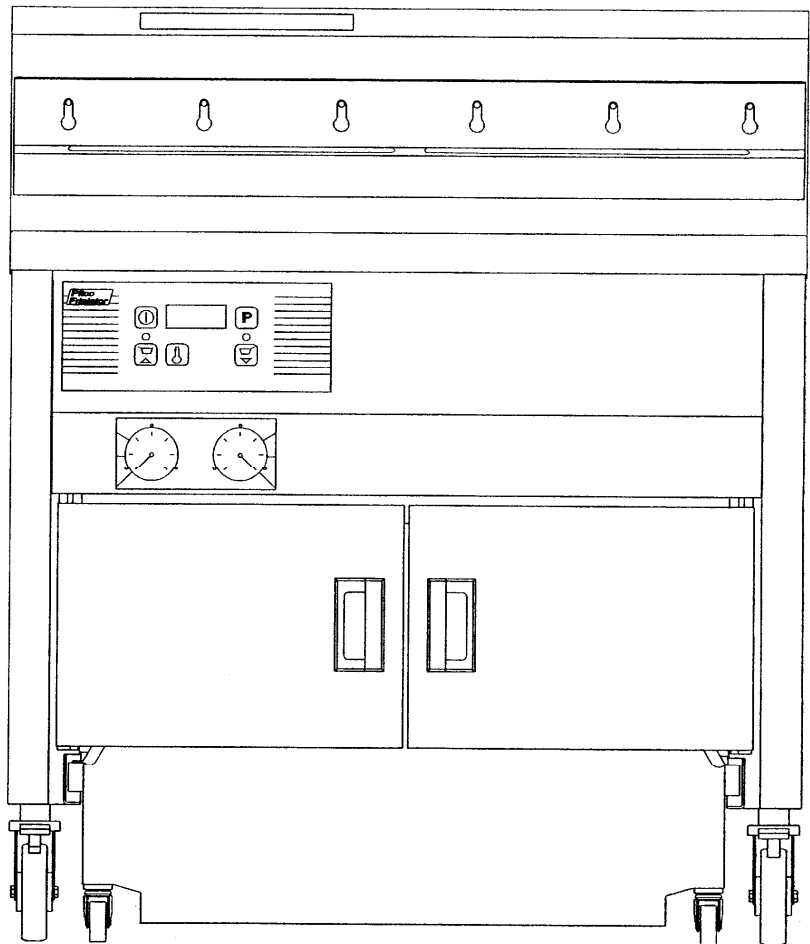

Literature # L20-155 Rev 1

Patent Pending

Manufactured in  
The United States of America

**FOR YOUR SAFETY:**

**Do not store gasoline or other flammable vapors or liquids in the vicinity of this or any other appliance.**

**TO THE PURCHASER**

**POST IN A PROMINENT LOCATION INSTRUCTIONS TO BE FOLLOWED IN THE EVENT THAT AN OPERATOR SMELLS GAS. OBTAIN THIS INFORMATION FROM YOUR LOCAL GAS SUPPLIER.**

**WARNING:**

**IMPROPER INSTALLATION, ADJUSTMENT, ALTERATION, SERVICE OR MAINTENANCE CAN CAUSE PROPERTY DAMAGE, INJURY OR DEATH. READ THE INSTALLATION, OPERATING AND MAINTENANCE MANUALS THOROUGHLY BEFORE INSTALLING OR SERVICING THIS EQUIPMENT.**

**WARNING**

DO NOT use an open flame to check for gas leaks! Keep all open flames away from the machine at all times.

**WARNING**

Machines equipped with casters and a flexible power cord, must be connected to a gas supply with a Quick-Disconnect device. This quick disconnect must comply with ANSI Z24.41. To limit the movement of the unit without depending on the connector or quick disconnect, a restraining cable must also be installed.

**WARNING**

Use only a B/C or A/B/C extinguisher that contains the dry chemical Sodium Bicarbonate or Potassium Bicarbonate should be used to extinguish any fires.

**WARNING**

Ensure that the machine can get enough air to keep the flame burning correctly. If the flame is starved of air it can give off a dangerous carbon monoxide gas. Carbon Monoxide is a clear odorless gas that can cause suffocation.

**WARNING**

Blocking the flue will also cause the unit to overheat. DO NOT obstruct the flow of combustion/ventilation or air opening around the machine. Ensure that you meet the minimum clearances specified in the installation instructions. Adequate clearance around the unit is necessary for servicing and proper burner operation.

**WARNING**

The power supply must be disconnected before servicing or cleaning the unit.

**WARNING**

DO NOT supply the fryer with a gas that is not identified on the data plate, located on the inside of one of the doors of the machine. If you need to convert the machine to another type of fuel, contact your dealer or Authorized Blodgett Service Agency.

**WARNING**

When the fryer is in its operating location, lock the casters and reattach the restraining device to the rear of the machine.

**WARNING**

Shortening, when it is at cooking temperatures, is very HOT and DANGEROUS! Use extreme caution when handling! Use the proper protective gear such as insulated gloves, aprons, face shield and sleeves when handling hot shortening. DO NOT attempt to move any machine that has hot oil in it. Allow the oil to cool to room temperature or drain the oil into a suitable container before moving the fryer.

# ORIGINAL EQUIPMENT LIMITED WARRANTY - TURBOFRY 2000

## General Warranty

Pitco Frialator, Inc. warrants to the original user of its **Turbofry 2000** cooking appliance that said appliance and related equipment will be free from defects in material and workmanship under normal use for a period of one (1) year from the date of installation, with appropriate documentation, subject to the following additions, exceptions, exclusions and limitations.

### What is covered

This warranty is limited to the repair or replacement at the Company's option, without charge, of any part found to be defective within the warranty period and reasonable expenses incurred for freight and material for the installation of such part; in addition, the Company's obligation shall be limited to reimbursement for normal labor on such parts.

Pitco Frialator, Inc. agrees to pay the G.S. Blodgett Corporation Authorized Service and Parts Distributor, for any labor and material required to repair or replace, at the Company's option, any part which may fail due to defects in material or workmanship during the above general warranty period.

### Fry Tanks

In addition, the Company warrants to the original user of any fry tank to be free from defects for a period of ten (10) years from the date of manufacture. Labor and freight shall be the responsibility of the user. This shall only obligate the Company to repair or replace, at its option, any fry tank which it determines to be defective. Claims under this item shall be supported by a statement detailing the defect, and the Company may require the return of the fry tank claimed to be defective.

### Computer or Digital Cooking Controller

In addition, the Company warrants to the original user of any Cooking Computer or Digital Controller to be free from defects for a period of two (2) years, from the date of manufacture. During the two (2) year period all charges involved in the replacement of a Pitco Computer or Digital Controller will be the responsibility of Pitco Frialator Inc.

### How to Keep Your Warranty in Force

- Make sure any shipping damages are reported immediately. Damages of this nature are the responsibility of the carrier.
- Install the unit properly. This is the responsibility of the installer and the procedures are outlined in the manual. Do not install it in a home or residence.
- Maintain the unit properly. This is the responsibility of the user, the procedures are outlined in the manual.

### What is NOT covered under this Warranty

- Adjustments, such as calibration, leveling, tightening of fasteners or plumbing or electrical connections normally associated with initial installation are not covered under this warranty. These procedures are outlined in the installation manual.
- Damaged due to flood, fire or other acts of Nature are not covered under this warranty.
- If the unit is used for a purpose other than for which it was intended or designed, resulting damages are not covered under the warranty.
- Failures due to erratic voltage or gas supplies are not covered under the warranty.
- Material alterations or modifications from the condition in which the unit left the factory are not covered under the warranty.
- Units with unreadable, obliterated or removed serial number rating plates are not covered by the warranty.
- Any parts other than Genuine OEM parts from Pitco Frialator, Inc. or its Authorized Parts and Service Distributors are not covered by the warranty.
- Any other failure which is not attributable to a defect in materials or workmanship is not covered by the warranty.

This warranty specifically excludes parts which wear or would be replaced under normal usage, including, but not limited to, electric lamps, fuses, interior or exterior finishes and gaskets.

### Limits to the Warranty

Outside the United States of America and Canada, this warranty is limited to the replacement of parts and Pitco Frialator, Inc. will not bear any other expense be it labor, mileage, freight or travel.

Charges for mileage over one hundred (100) miles, travel time over two (2) hours, overtime, and holiday charges are not covered under this warranty. These charges are the responsibility of the individual or firm requesting these services.

If any oral statements have been made regarding the appliance, these statements do not constitute warranties and are not part of the contract of sale. This limited warranty constitutes the complete, final and exclusive statement with regard to warranties.

**THIS LIMITED WARRANTY IS EXCLUSIVE AND IS IN LIEU OF ALL OTHER WARRANTIES WHETHER WRITTEN, ORAL OR IMPLIED, INCLUDING, BUT NOT LIMITED TO ANY WARRANTY OF MERCHANTABILITY OR FITNESS FOR A PARTICULAR PURPOSE OR WARRANTY AGAINST LATENT DEFECTS.**

### Limitations of Liability

In the event of a warranty or other claim, the sole obligation of Pitco Frialator, Inc. will be the repair or replacement, at the Company's option, of the appliance or the component part. This repair or replacement will be at the expense of Pitco Frialator, Inc. except as limited by this warranty statement. Any repair or replacement under this warranty does not constitute an extension in time to the original warranty. Parts covered under this warranty will be repaired or replaced, at the Company's option, with new or functionally operative parts. The liability of Pitco Frialator, Inc. on any claim of any kind, including claims based on warranty, express or implied contract, negligence, strict liability or any other legal theories will be exclusively the repair or replacement of the appliance. This liability will not include, and the purchaser specifically renounces any right to recover special, incidental, consequential or other damages of any kind, including, but not limited to, injuries to persons, damage to property, loss of profits or anticipated loss of the use of this appliance.

If any provision of this warranty is unenforceable under the law of any jurisdiction, that provision only will be inapplicable there, and the remainder of the warranty will remain unaffected. The maximum exclusion or limitation allowed by law will be substituted for the unenforceable provision.

### How to Obtain Warranty Service

First direct your claim to the G.S. Blodgett Corporation Authorized Service and Parts Distributor closest to you giving complete model, serial and code numbers, voltage, gas type, and description of the problem. Proof of the date of installation and/or the sales slip may also be required. If this procedure fails to be satisfactory, write the National Service Manager, Pitco Frialator, Inc., P. O. Box 501, Concord, NH. 03302-0501. USA

This warranty gives you certain specific legal rights; you may have other rights which vary from state to state.

# Table of Contents

ORIGINAL EQUIPMENT LIMITED WARRANTY .....	ii
TABLE OF CONTENTS .....	iii
SPECIFICATIONS and DATA .....	iv
INTRODUCTION .....	1
How does it work? .....	1
230 VAC, High Voltage System .....	1
24 VAC, Low Voltage System .....	2
Component Recognition - Fry Tank .....	5
Component Recognition - Controls .....	6
PREVENTATIVE MAINTENANCE .....	7
Daily Cleaning .....	7
Weekly Cleaning .....	7
Vacuum Gauge Inspection .....	7
Boil Out Procedure .....	7
Air Filter Inspection .....	9
Inspect O-Rings .....	10
Service Technician Inspection .....	10
TROUBLESHOOTING .....	11
COMPONENT TROUBLESHOOTING .....	12
Temperature Probe .....	12
Relays .....	12
Hi Limits .....	12
Drain Valve & Return Valve Switches .....	12
Transformer .....	12
Blower .....	13
Pressure Switch .....	13
Ignition Control Modules .....	13
Ignitors .....	13
PARTS .....	15
General .....	15
Entrance Box Assembly .....	16 - 17
SCHEMATICS .....	18 - 20
700268 Rev C - Page 1, Left Side of schematic .....	18
700268 Rev C - Page 1, Right Side of schematic .....	19
700268 Rev C - Page 2 .....	20

## SPECIFICATIONS and DATA

Gas Consumption .....	240 kbtu/hr
Efficiency .....	71-73%
Cooking capacity, fries .....	260 lb/hr
Supply Voltage .....	208 - 230 VAC
Control Voltage .....	24 VAC
Heat up time - Liquid .....	20 mins
Heat up time - Solid .....	25 mins
Minimum melt time - Solid only .....	10 mins
Sump Thermostat temp .....	Open at 135°F
	Close at 105°F
Spark Gap .....	0.1 ± 0.005" (2.54 ± 0.127mm)
Hi Limit specs .....	435 - 465°F
Burner flame color .....	Yellowish blue
Blower speed .....	Set by Speed control
Ignition lockout time .....	15 secs
Pressure switch .....	Open below 0.8" WC (0.2 kPa)
	Close above 0.1" WC (0.325 kPa)
Blower Air High Fire Pressure .....	Nat - 5.5 - 5.6" WC
	LP - 4.8 - 4.9" WC
Blower Air Low Fire Pressure .....	Nat - 0.4" WC
	LP - 0.4" WC
Gas Pressure at Tap in High Fire Gas Line .....	Nat - 4" WC
	LP - 3.5" WC
Heat Time from 250°F to 300°F .....	2:25 - 3 Minutes
Pump Rate, clean oil, Full Pan to Fry Tank .....	5 - 5:45 Minutes/Seconds
Pump Rate, clean oil, to empty Circulating System .....	45 Seconds
(This is done after the Tank has been cleaned, drained and the filters removed)	
Low Fire Orifice Size .....	Nat & LP - #54 Drill Size
Hi Fire Orifice Size .....	Nat - 0.328"
	LP - 0.302"
Air Bleed Tip Orifice .....	Nat - #52 Drill Size
	LP - #45 Drill Size
Air collar Size .....	Nat - 1.06"
	LP - 1.165"
Minimum Gas Pressure Requirments .....	Nat & LP - 5.0" WC
Maximum Gas Pressure Requirements .....	Nat & LP - 14" WC

## INTRODUCTION

The development of the TURBOFRY 2000 fills the needs of the food industry that have been, until now, unattainable. They are:

1. *Continuous filtration of the food oil.*
2. *Crispier than ever fried food coatings due to convection currents.*
3. *High production from a high efficiency heat transfer system.*

Continuous filtration of the cooking oil provides clean, clear oil, even through busy periods. This means breaded particles do not settle on heating surfaces and burn, which in turn means longer oil life and lower oil costs. The clean oil produces foods with coatings free of burnt food particles that look and taste more appetizing. Turbofry 2000 has an advanced filter system that makes clean up quick and easy. The main filters trap the larger crumbs and can be lifted out for easy cleaning and replacement.

The Turbofry 2000 uses a heating process, within the cooking area, known as "Convection", foods cook with crisper coatings because hot oil is forced between the individual pieces of food, the breading or outer coating gets seared quickly before the food can absorb as much oil as with a standard fryer. This will produce a finished product that is much lower in absorbed oils.

The Turbofry 2000 has a high efficiency gas combustion system that transfers heat more efficiently than regular fryers. The high input rate in conjunction with a large heat transfer surface area give this fryer the ability to cook high capacity loads effortlessly.

When installing the Turbofry 2000 follow the instructions in the **Installation and Operating Manual**.

## How does it work?

There are two parts to the control system in the Turbofry 2000 fryer, the 230 VAC or high voltage circuit and the 24 VAC or low voltage circuit.

### 230 VAC, High Voltage System:

230 VAC is applied to the machine -

- The Pump Motor Relay switch contact are supplied with 230 VAC.
- The Sump Heat System is supplied with 230 VAC. When the Sump Temperature Switch closes the Sump Heat Tape will start to heat.
- The Motor Relay switch contacts will be supplied with 230 VAC. This relay will be explained later in this manual.
- On machines equipped with the Solid Shortening Option the switch contacts of the Heat Tape Relay will also be supplied with 230 VAC. This relay is controlled by the Pipe Temperature Switch.
- The primary coils of the Transformer will be supplied with 230 VAC. At this point the 24 VAC, low voltage circuit will become energized.

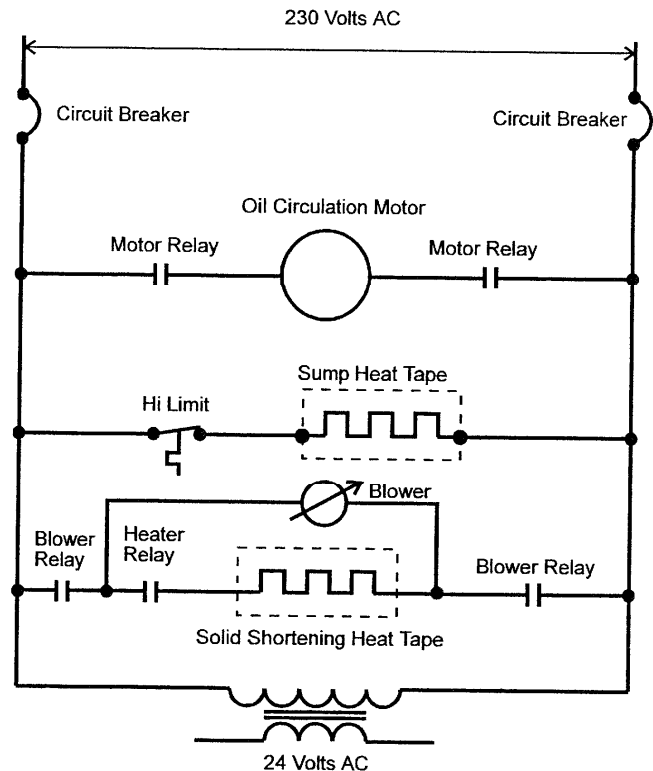

**24 VAC, Low Voltage System:**

Digital Control -  
 Condition - Power supply ON Digital Control OFF.

- 24 VAC is supplied to the Digital Temperature Controller.
- The Drain Valve Switch is supplied with 24 VAC. If the Drain Valve is closed the switch will allow 24 VAC to be supplied to the Drain Interlock connection at the Controller.
- The Power Relay switch contacts will also be supplied with 24 VAC.

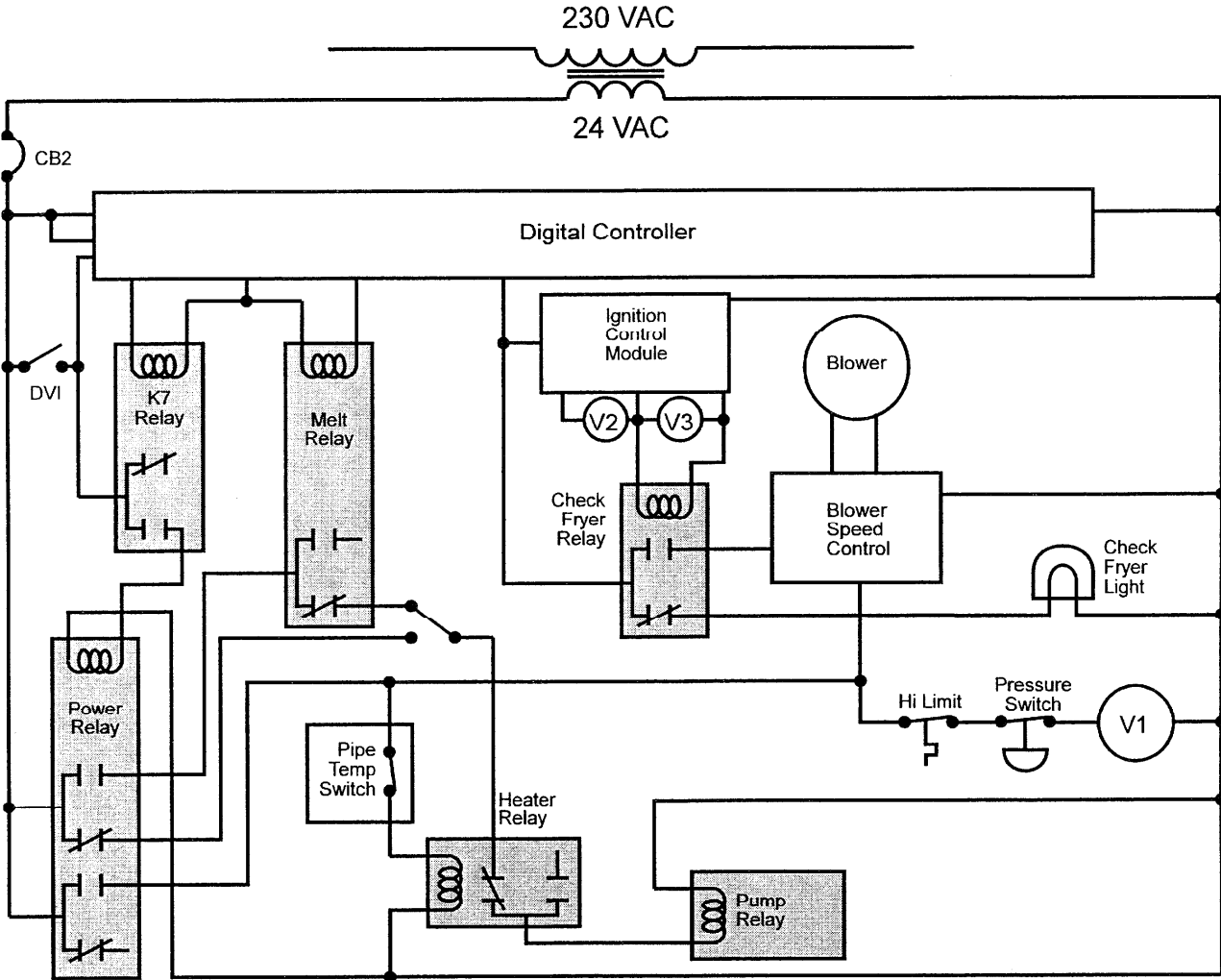

**Condition - Digital control is switched ON but there is NO demand for heat:**

- 24 VAC is supplied to the On Relay (K7) relay which energizes and supplies 24 VAC to the coil of the Power Relay (K1).
- The Power Relay (K1) energizes and supplies 24 VAC to following places:
  - Hi Limit Switch (S2) - If the Hi limit (S2) is closed 24 VAC is supplied to the Pressure Switch (PS1), the Pressure Switch (PS1) will close and supply 24 VAC to the Gas Valve (V1) when the Blower (M2) comes up to speed.
  - Melt Relay (K2) - if the Digital Control (A1) is in Melt Cycle the Melt Relay (K2) is energized and the circuit will be open. If the Digital Control (A1) has completed the Melt Cycle the Melt Relay (K2) will be de-energized and the Pump Override Switch (S1) will be supplied with 24 VAC.
  - Blower Speed Control (VR1) - the Blower Speed Control (VR1) will cause the Blower (M2) to run in Low Fire mode until it receives a signal from the Check Fryer Relay (K5) to tell it to run in the High Fire mode.
  - Pipe Temperature Switch (TS1) - When the temperature in the filter piping falls below a certain level the Pipe Temperature Switch (TS1) will close and supply 24 VAC to the Heater Relay (K6). In this state the Heat Tape (HR2-HR6) will be supplied with 230 VAC and will continue to heat until the Pipe Temperature Switch Opens at its designed temperature.

**Condition - Demand for heat (All Controls):**

- 24 VAC is supplied to the switch points of the Check Fryer Relay (K5). Since the Check Fryer Relay is energized by the Ignition Control Module when it runs in High Fire Mode it will remain de-energized and the Check Fryer Light (DS1) will be illuminated.
- 24 VAC is supplied to the Ignition control Module at terminal #6. The Ignition Control Module will cause a spark at the Ignitor (PR1) and supply the Gas Valve (V2) with 24 VAC. At this time the Low Fire flame will ignite. The Ignition Control Module will seek a flame sense signal from the Ignitor (PR1). The Ignition Control Module will then supply 24 VAC to the Gas Valve (V3) and the High Fire Flame will run. (Under normal working conditions it should take 2.6 - 4 seconds for the High Fire Flame to light.) The same 24 VAC signal supplied to the Gas Valve (V3) is also supplied to the Check Fryer Relay (K5). When the Check Fryer Relay energizes it will stop supplying 24 VAC to the Check Fryer Light and start supplying 24 VAC to the Blower Speed Control. The Blower speed will then increase to High Fire speed which will sustain the air demand for High Fire.

**Condition - Auto Pump start (All Controls):**

- The Pump Relay (K4) is supplied with 24 VAC from the Heater Relay (K6) and, if all of the following conditions are met, the Circulation Pump (M1) will begin to run:
- When the Controller is turned off the Power Relay (K1) is de-energized which supplies 24 VAC to one side of the Pump Override switch (S1). If the pump is NOT running the Pump Override Switch (S1) will be in the open condition. In the open position the Pump Override Switch will be in the correct position for Automatic Pump Start. When the Control is first turned on it will send a 24 VDC signal to the coil of the Melt Relay (K2). This will energize the relay and open the circuit to the Pump Override Switch. When the Control has exited the Melt Cycle or run past the Minimum Melt Time it will stop supplying the Melt Relay (K2) with 24 VDC and the Pump Override Switch will be supplied with 24 VAC. At this time, assuming the Sump Temperature is above 135°F (57°C) and the Heater Relay is de-energized the Pump Relay (K4) will be supplied with 24 VAC and the Circulation Pump will be supplied with 230 VAC.

**Condition - Computer Control Option:**

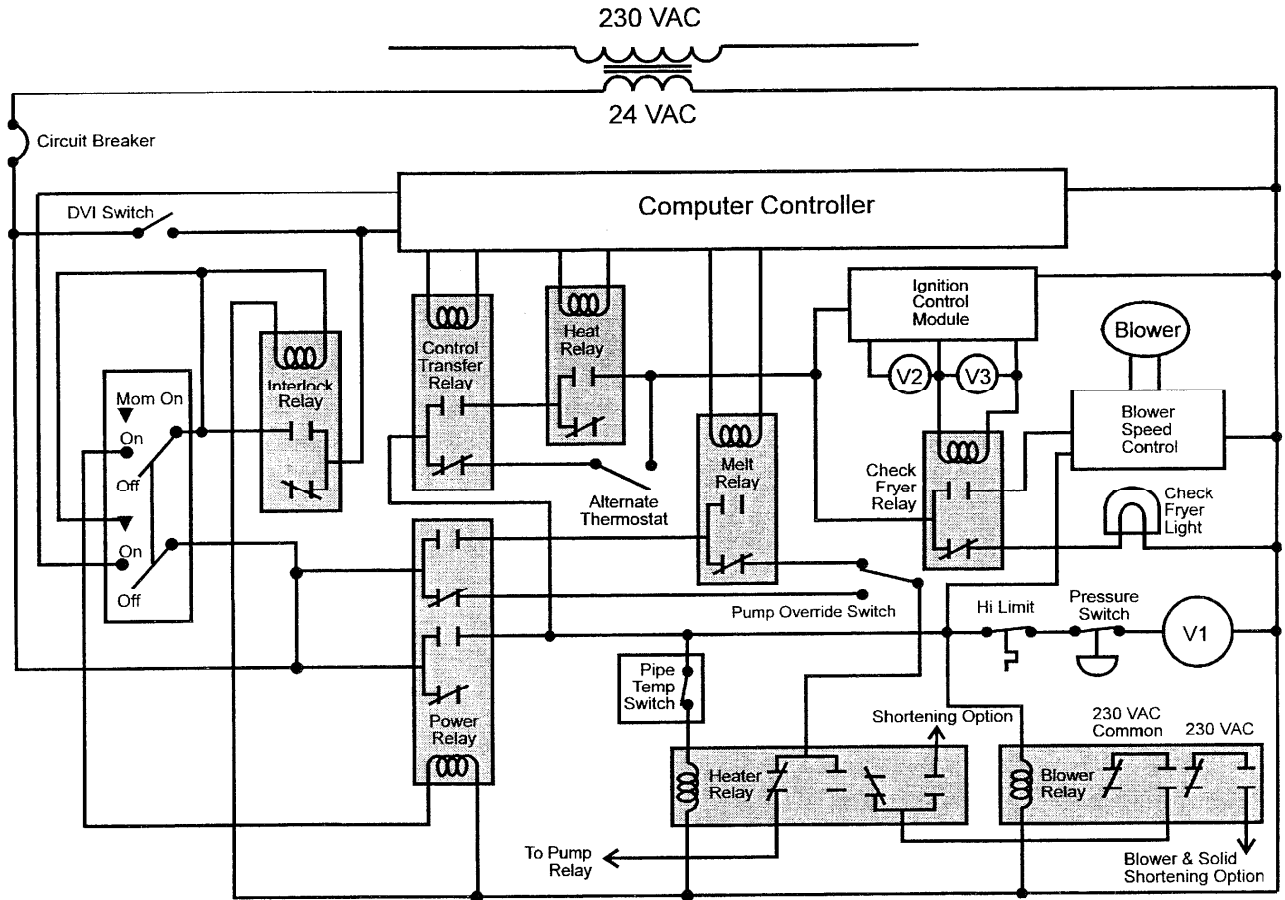

- In order to supply power to the computer the OFF/ON START Switch (S6) must be in the ON position. The following conditions must be met before the machine can begin heating:
  - The Drain Valve Interlock Switch (S3) must be closed.
  - The Interlock Relay (K10) must have been energized by pressing the OF/ON/START Switch (S6) to the START position and releasing. The Interlock Relay (K10) will stay latched until the Drain Valve Switch (S3) is opened or the power is cut to the machine. When the Interlock Relay (K10) is latched it will supply a continuous 24 VAC to the Power Relay (K1). When the Computer Control (A2) is supplied with 24 VAC it will supply the Control Transfer Relay (K8) with 24 VDC, if there is an open circuit condition on the Probe (PR1) the Computer Control (A2) will stop supplying the Control Transfer Relay (K8) with 24 VDC causing it to de-energize and allowing the Alternate Thermostat (S5) to control the Heating of the oil. When the Computer Control (A2) calls for heat it will supply 24 VDC to the coil of the Heat Demand Relay (K9) which will cause the machine to heat in a manner previously described.

**Component Recognition - Fry tank:**

The Turbofry 2000 uses a new frying and filtering technology, therefore it is important that you become familiar with the major components inside and outside of the fry tank. The following drawing and index shows these components and their uses:

1. Flue opening - The HOT exhaust gases from combustion will rise from this opening.
2. Burner Heat Tube - Combustion takes place within this tube. The heat radiates out from this tube and from the sides of the fry tank.
3. Hi Limit Probe - The Hi Limit is the safety device that will shut the machine down should the temperature become excessively high.
4. Temperature Sensing Probe - This probe is used by the Digital/Computer Control to sense the actual temperature of the oil.
5. Oil Circulation Tube Assembly - The filtered oil is returned to the fry tank through this tube. It has many orifices along the underside to direct the oil streams into the bottom of the fry tank. There is a handle welded to the end of the tube.
6. Filter Bag Retainers - The Filter Bags "Hang" on the retainer which fits snugly in the Filter Bag Housing.
7. Drain - Oil will drain from this opening when the Drain Valve Handle is opened.
8. Filter Bag Housing Lifting Points - Use the supplied lifting tool to lift the Housing out.

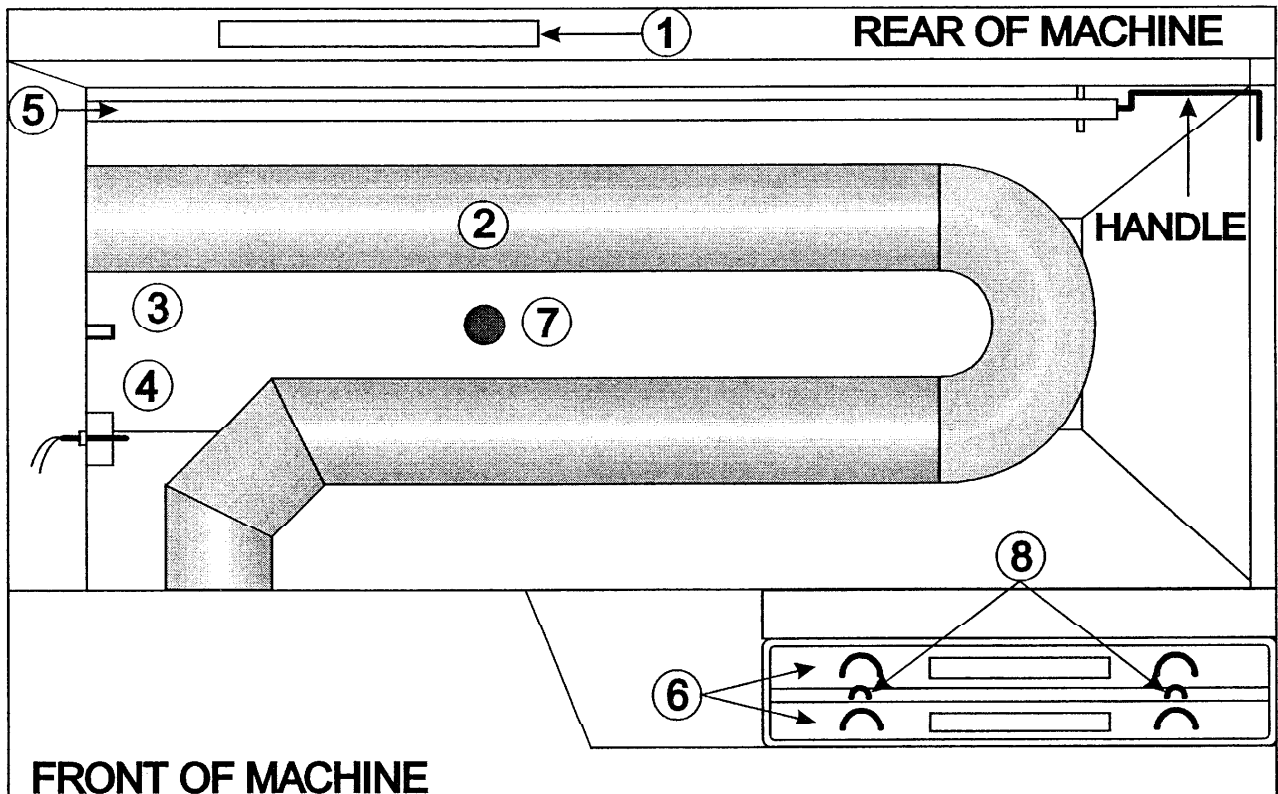

**Component Recognition - Controls:**

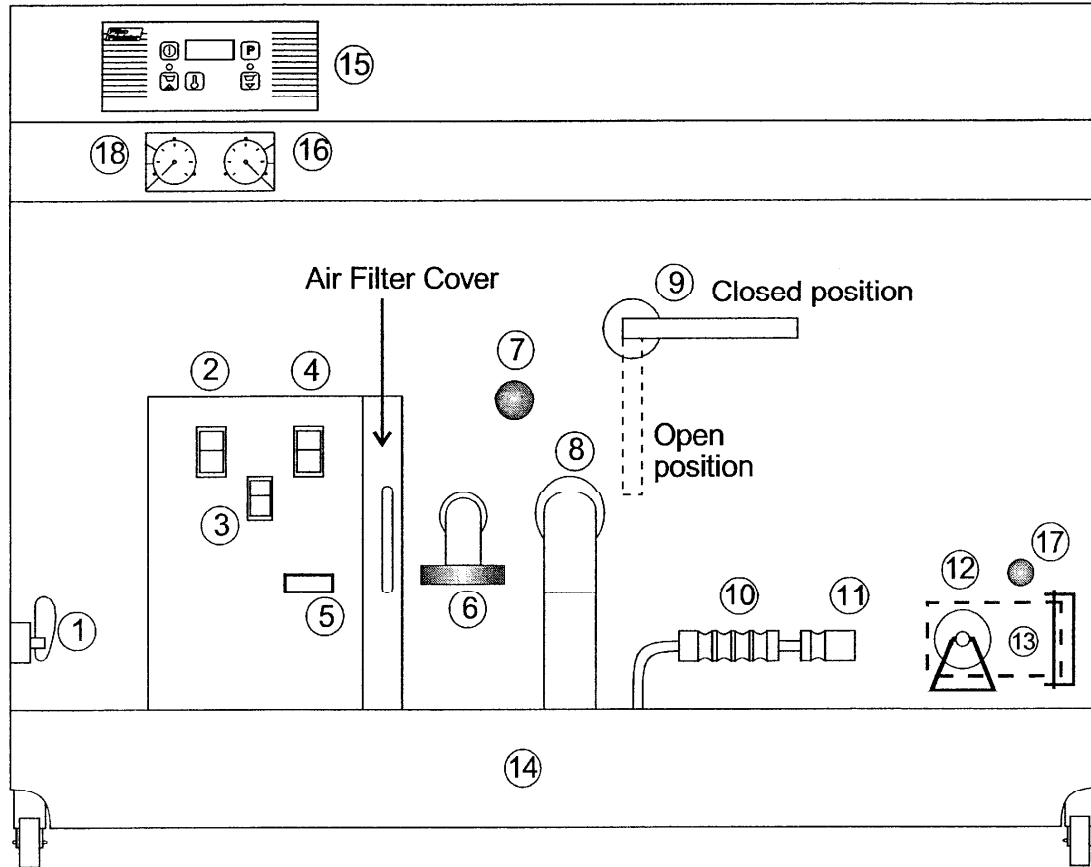

1. Gas Shut Off Valve.
2. Master Circuit Breaker - Protects all circuits in the machine.
3. Pump Override Switch - Manually turns the filter pump ON or OFF independently of the current operation mode. This switch is locked out while the control is in the melt cycle mode.
4. Control Circuit Breaker - Protects the control circuit only.
5. Check Fryer Indicator Light - Indicates burner ignition status.
6. Flush Hose Connector - When needed the Flush Hose is connected here.
7. Pump Outlet Selector - Used to direct the oil to the Fry Tank or the Flush Hose.
8. Drain Outlet Pipe - Allows the oil to be drained into the Lower Pan or a high temperature disposal container.
9. Drain Valve Handle - Green.
10. Lower Pan Pick Up Assembly - Connects the Lower Pan to the Pump Suction Connection.
11. Pump Suction Connection.
12. Sump Screen Assembly - This Screen prevents any debris from getting into the pump during a Filter Bag Change procedure.
13. Sump Drain Handle - When this is pulled away from the Sump Screen Assembly it opens a valve to drain the Sump so that it can be removed from the machine safely.
14. Lower Pan Assembly - Holds the cooking oil while the filter bags are being changed.
15. Digital/Computer Control - Controls operating and cooking functions (Digital Control shown.)
16. Vacuum Gauge - Shows the status of the main filters.
17. Pump Inlet Selector Knob - Used to change the pump inlet from Main Filter to the Lower Pan Assembly.
18. Oil Circulation Tube Gauge - Indicates when the Oil Circulation Tube needs cleaning.

**PREVENTATIVE MAINTENANCE:**

In order to keep your new Pitco Frialator Turbofry 2000 operating and looking in top condition it is necessary to perform a few simple tasks on a daily, weekly, monthly and quarterly basis. Follow the chart below to find the frequency at which these Preventative Maintenance Items should be performed:

Cleaning	Daily and Weekly
Vacuum Gauge Inspection	Daily
Boil Out	Monthly or when needed
Air Filter Inspection	Every 3 months
Inspect O-Rings on- Filter Bag Housing	Every 3 months
Oil Circulation Tube	Every 3 months
Sump Screen	Every 3 months
Service Tech Inspection	Yearly

Follow the directions outlined below for the instructions on how to perform the given task:

**Daily Cleaning:**

It is recommended that, in addition to filtering, the external components of the fryer be cleaned in the following manner.

Turn the fryer OFF by pressing the **⓪** key on the Digital Control panel, or pressing the power switch to the OFF position. Using a soft clean cloth to wipe the exterior surfaces until they are free of oil. A small amount of non abrasive cleaner may be used on stubborn stains.

**Weekly Cleaning:**

At least once a week the following preventative maintenance procedures should be performed:

- Clean Filter Bag Housing
- Clean Pump Suction Screen
- Clean Oil Circulation Tube
- Clean Fry Tank using the Boil Out procedure

Follow the instructions below for instructions on each of these items:

**Filter Bag Housing** - After the oil has been drained from the Filter Bag Housing use the supplied Filter

Bag Removal Tool to lift the complete Filter Bag Housing out of the machine. Wash the Filter Bag Housing with soap and water to remove all debris. Dry thoroughly and install in the machine. Make sure the Housing is seated correctly before installing the Filter Bags.

**Pump Suction Screen** - Follow the instructions outlined in the Main Filter Bag Changing Procedure. Use an abrasive, NON metallic, scouring pad on persistent stains.

**Oil Circulation Tube** - Grasp the Oil Circulation Tube Handle and pull to the right until it is free from the housing. Lift the Oil Circulation Tube from the fry tank. The Oil Circulation Tube may be washed with soap and water. Use a toothpick or similar tool to push the crumbs and debris out of the circulation holes. Thoroughly dry the Oil Circulation Tube and reinstall by carefully aligning the end in the housing, lower the handle until it is seated on the bracket. Push the Oil Circulation Tube into the housing until it seats.

**Vacuum Gauge Inspection:**

Each time that the pump is switched off or the machine shuts the pump off during a Filter Bags Change, check the Vacuum Gauge to make sure the needle points to the zero mark. The Vacuum Gauge will only point to zero when the pump is NOT running. If it does not point to the zero or very close call an Authorized Service Agency to have the Vacuum Gauge checked.

**Boil Out Procedure:**

Periodically it will be necessary to perform what is known as a **Boil Out**. This removes baked on frying oil from the inner surfaces of the fry tank. The best time to accomplish this is when the oil is ready to be replaced.

Due to the unique design of the TURBOFRY 2000, the **Boil Out** procedure is more involved than that of a regular fryer. Always use Pitco Fryer Cleaner to boil out the TURBOFRY 2000. Other cleaners not approved by Pitco may be harmful to materials used in the construction of the TURBOFRY 2000. Any



damage done by the use of other cleaners will not be covered by the Pitco warranty.

The Procedure has 3 main parts - Cleaning, Neutralization and Rinsing:

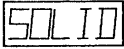
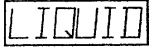
**Cleaning:**

1. Check that the controller is programmed to heat with a melt cycle, the Digital display will show . (The Computer display will show  or .)
2. Check the current Set Temperature setting of the controller. Reprogram the controller to a temperature setting of 200° F. (Follow the instructions in the appropriate section of this manual.)

**Notice** - Even though we call this a **Boil Out**, there is no need to boil the water. 200°F is hot enough for the cleaner to work and will prevent the mess and hazards of a boil over.

3. Shut the fryer OFF by pressing the  key on the Digital controller. (Press the OFF/ON/START switch to the OFF position on Computer controlled machines.)
4. Drain all of the oil from fry tank and filter bags into the lower pan by opening the Green Drain Valve (#9, page 6). Remove any pieces of food that may have accumulated on the bottom of the fry tank or in the Sump and Sump Screen. Remove the Sump Screen assembly (#12, page 6) and clear any particles from it. Return the Sump Screen assembly to its housing and make sure it is seated. Remove the soiled Filter Bags and install clean ones.
5. Fill the fry tank with water to the OIL LEVEL mark on the inside of the fry tank.
6. Turn the fryer ON by pressing the  key on the Digital control. (Press the OFF/ON/START switch to the ON position on Computer controlled machines.)

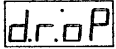
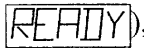
**Notice** - Allow the fryer to heat for 10-15 minutes until the Digital display changes to  (Computers will show ) before adding Pitco cleaner. Adding cleaner while the fryer is heating up

could cause a boil over. At this time the pump should have started to circulate the water.

7. Add 8 Ounces by weight of Pitco Fryer Cleaner to the water. (4 sample packets, supplied with your new fryer.)
8. Allow the Pitco Fryer Cleaner and hot water to soak with the pump running for 45 minutes, the fryer will hold the cleaning compound at 200°F.
9. While the cleaner is soaking, use the white fryer cleaning brush to scrub all the inner surfaces of the fry tank, splashback, basket hanger, and the fry baskets.
10. After 45 minutes, turn the fryer OFF by pressing and holding the  key on the Digital control. (Press the OFF/ON/START switch to the OFF position on Computer controlled machines.)
11. Rotate the Drain Outlet Pipe (#8, page 6) to point outward. Place a heat resistant 3-5 gallon container under the Drain Outlet Pipe. The water should be disposed of in a responsible manner.
12. Drain the fry tank by slowly opening the Green Drain Valve Handle (#9, page 6). The used **Boil Out** water and Pitco cleaner is safe to pour down a sink drain.

**Notice** - The water from the fryer could be hot enough to damage plastic drain systems. Run cold tap water as you pour the hot cleaner down the drain to protect plastic drain systems.

13. Turn the pump on by pressing the Pump Override Switch (#3, page 6) to drain the filters. Allow the pump to run until the Filter Bags are empty of water. Remove and dispose of the soiled Filter Bags.
14. Use a Green Scouring Pad or similar Non Metallic abrasive cleaning pad to remove any carbonized deposits from the inner surfaces of the fry tank. Rinse all surfaces after scrubbing.
15. Remove the Oil Circulation Tube Assembly (#5, page 5) and rinse it. Rinsing should be done from the outside of the Circulation holes to the inside of the tube to prevent plugging the holes, a toothpick or similar tool may be used to clear any blockages in the holes.
16. If after completing the previous steps, the fry tank

is not cleaned to your satisfaction, repeat steps 5 through 15. If the fry tank is clean go to step 17. If the fryer cleaner did not clean the fryer adequately, then **Boil Outs** should be performed more frequently to prevent heavy build up.

17. Use clean water to rinse the fryer cleaner out of the fry tank. Use the brush or a clean towel to rinse all surfaces that were contacted by the fryer cleaner. Repeat the rinsing until all surfaces are free of cleaner residue.

**Notice** - If you are using the recommended Pitco Fryer Cleaner (Pitco part Number P6071397) which is a "Non Caustic" cleaner or another brand Non Caustic cleaner skip the Neutralization steps (18 through 23).

#### **Neutralization:**

18. Fill the fryer with fresh water to the OIL LEVEL line on the rear of the fry tank. Add 1/2 gallon of white vinegar to the water.
19. Connect the flush hose to the flush hose fitting. Start the pump by pressing the Pump Override Switch (#3, page 6). Let the pump run for 1-2 minutes. Stop the pump. Pull the Pump Outlet Selector (#7, page 6) to the Flush Hose position, place the end of the hose nozzle into the fry tank, and start pump by pressing the Pump Override Switch. This will neutralize the cleaner in the flush hose lines. Use the brush or a clean towel to wipe the neutralizer solution over all the parts that were cleaned with the fryer cleaner. Once the entire fryer has been neutralized, drain the fry tank and filter sump by following steps 12 and 13.
20. Close the Green Drain Valve Handle (#9, page 6) and fill the fryer with fresh water to the OIL LEVEL line on the rear of the fry tank. Rinse the fry tank, splashback, basket hanger, and the fry baskets. Operate the pump as in step 19.
21. Drain the fry tank and filter sump of all water, by opening the Green Drain Valve Handle (#9, page 6). This includes removing the Sump Screen Assembly (#12, page 6) and allowing all water to drain from the sump housing. Replace the Sump Screen Assembly in the sump housing and return the Sump Drain Handle (#13, page 6) to its normal operating position.
22. Wipe the fry tank, splashback, basket hanger, and the fry baskets with clean dry towels to remove all water. Install the Oil Circulation Tube Assembly (#5, page 5). This completes the neutraliza-

tion part of the **Boil Out** procedure.

23. Install new filters in the filter sump. Pull the Pump Inlet Selector Knob (#17, page 6) to the "Lower Pan" position.
24. Turn the Drain Valve Handle (#9, page 6) counter clockwise to the "Closed" position. Use the Pump Override Switch to start the pump and pump all of the oil from the lower pan to the fry tank to a level 1/2" below the OIL LEVEL mark at the rear of the fry tank.

#### **CAUTION:**

The next step will be very noisy as the fryer evaporates the remaining water in the fry tank and pump lines. Allow the pump to run the entire time it takes to evaporate the residual water. If the pump is not left running, there is a chance that steam could build up in the unit and discharge hot oil.

25. Turn the fryer on using the (Ⓛ) key. Enter the program mode to reset the temperature to the original setting as shown in the Operating Manual. The fryer will now heat the oil and evaporate any remaining moisture.
26. Allow the fryer to heat the oil until all the moisture from the boil out is evaporated. The amount of time required to do this will vary with the degree of dryness that was achieved during the wipe down after rinsing, generally it takes 15 -20 minutes to dry the oil.

**Notice** -The best way to tell if the system has dried out is by the appearance of the oil. When the oil is dry, there will be no small bubbles visible in the oil. At this point the fryer can be shut down.

27. Shut the fryer OFF by pressing the (Ⓛ) key on the Digital controller. (Press the OFF/ON/START switch to the OFF position on Computer controlled machines.) Drain fry tank and filter sump and dispose of the used oil.
28. Fill the fryer with new cooking oil. The **Boil Out** is now complete.

#### **Air Filter Inspection:**

Remove the 8 screws that hold the Air Filter cover in place (see page 6), grasp the handle and pull outward until the entire Air Filter extends out of its housing.

Inspect the air Filter for dirt and debris. If the Air Filter has a light coating of dust, it may be removed and cleaned by gently tapping it against a hard surface so that the particles fall out of the filter material. Check for anything that may obstruct air flow. If, for any reason, the Air Filter requires changing pull it out of the housing by lifting upwards and install a new Air Filter.

**Notice** - The Air Filter has a directional arrow on it. Make sure the arrow is pointing in the direction of the air flow.

Push the Air Filter Housing in until it stops and the cover seats, replace ALL of the screws and tighten them. Take care not to overtighten.

### **Inspect O-Rings:**

Choose a time when the machine has been cleaned and allowed to cool to perform any O-Ring inspection (see page 5). Take great care NOT to stretch the O-Ring.

**Filter Bag Housing** - Lift the Filter Bag Housing out as described in the Operation Manual. Using a small Dental Pick or Flat Tipped Screwdriver carefully lift the O-Ring out of its groove. Inspect the O-Ring for any Dry, Cracked or Flat surfaces, if the O-Ring has any of these symptoms it should be replaced.

To install the O-Ring, first clean the groove to make sure it is clear of any debris or pieces of old O-Ring. Cover the new O-Ring in a little cooking oil which will make the installation a little easier. Place the O-Ring in its groove making sure it is has not twisted during the installation. If it did twist gently untwist it and replace it in the groove. Make sure the O-Ring has seated in the bottom of the groove and reinstall the Filter Bag Housing.

**Oil Circulation Tube** - There is an O-Ring inside the housing where the Oil Circulation Tube seats. Use a Curved Dental Pick to extract the O-Ring. Inspect it for Dry, Cracked or Flat surfaces. To reinstall the O-Ring Place the O-Ring in its groove making sure it is has not twisted during the installation. If it did twist gently untwist it and replace it in the groove. Make

sure the O-Ring has seated in the bottom of the groove and reinstall the Oil Circulation Tube.

**Sump Screen** - Unscrew the Sump Screen (#12, page 6) as described in the Operation Manual. Inspect it for Dry, Cracked or Flat surfaces. To reinstall the O-Ring place the O-Ring in its groove making sure it is has not twisted during the installation. If it did twist gently untwist it and replace it in the groove. Make sure the O-Ring has seated in the bottom of the groove and reinstall the Sump Screen Assembly.

### **Service Technicians Inspection:**

On a yearly basis an Authorized Parts and Service Technician should perform the following Preventative Maintenance checks:

- 1.\* Remove and clean or replace the Air Filter.
2. Perform recovery test.
3. Check input gas pressure.
4. Remove burner and inspect for sooting or other damage.
5. Check calibration of controls.
6. Remove and replace the Pump Suction Connection O-Ring, Oil Circulation Tube O-Ring and the Sump Screen O-Ring.
- 7.\* Inspect the Filter Housing O-Ring, replace when needed.
8. On machines equipped with Heaters, check to make sure they are heating correctly.
- 9.\* Inspect the Vacuum Gauge to make sure it is returning to zero.

\* These are steps which the end user will normally perform, however, during the Technician' scheduled visit they are performed as part of the overall Preventative Maintenance (PM) service.

It is estimated that this should take approximately 2 - 2.5 hours.

### TROUBLESHOOTING:

Symptom	Cause	Repair
Vacuum Gauge in black area.	Filter Bags are clogged or are old.	Install new filters bags. Filters can be reused for up to 2 days. After 2 days, the fibers are saturated and the material is hardened, dispose of filters, replace.
High vacuum gauge reading.	Cold oil. Clogged Sump Screen. Incorrect Filter Bag installation, debris has clogged the Filter Bag Housing. Dirty or clogged Filter Bags. Filter Bag has a hole in it. Mechanical Problems.	Allow the oil to rise to operating temp and recheck the VACUUM GAUGE. Caused by a failure to clear the area around the filter bags before changing. Clean the Filter Bag Housing. Remove the Filter Bags and Filter Bag Housing, clean and reinstall. New Filter Bags should be used to prevent the introduction of debris to the system. Install a new Filter Bag. The Vacuum Gauge may be defective.
Low oil flow in cook zone, gauge needle in Yellow.	Filter Bags are becoming full.	Install new Filter Bags (Page 12).
Bubbles coming from the right rear corner of the fry tank.	Product has a high moisture content. Filter Bags are filling. Oil level is low. Pump Inlet Selector set to PAN.	This is a normal reaction to high moisture content. Check the Vacuum Gauge for Filter Bag status. Add cooking oil as needed. Push the Pump Inlet Selector Knob in to select the MAIN FILTERS position.
Low oil flow in cook zone, filter bags are clean.	Large amounts of high moisture content foods are being cooked.	This is normal and will dissipate shortly.
High pressure reading on PRESSURE GAUGE.	OIL CIRCULATION TUBE is becoming blocked. FLUSH HOSE valve not in fry pot position.	Remove the OIL CIRCULATION TUBE as and clean the orifices with a toothpick or similar item. Place the PUMP OUTLET SELECTOR in the FRY TANK position.
Cooking controller displays "dm" "trn" "off".	DRAIN HANDLE is in open position or has not been closed fully.	Close DRAIN HANDLE and refill the fry tank. Check the DRAIN HANDLE by pushing closed. The machine will have to be shut down and started up again as described Operating Manual.
No oil is coming out of the flush hose.	PUMP OUTLET SELECTOR is not set on FLUSH HOSE. No oil in LOWER PAN. LOWER PAN PICK UP ASSEMBLY not connected properly.	Check the position of the PUMP OUTLET SELECTOR and change as needed. Follow the directions outlined in the Operating Manual. Remove the LOWER PAN PICK UP ASSEMBLY and install it into the LOWER PAN PICK UP CONNECTION until it seats properly.

## COMPONENT TROUBLESHOOTING

### Temperature Probe:

The resistance of the probe decreases as the temperature rises. The lower the temperature the greater the resistance change will be per degree of temperature change, as the temperature approaches the working range of the probe, the resistance change will slow and become more linear. If the probe is suspect, check its resistance and the oil/air temperature at which it was taken. Compare these values on the chart below.

TEMP °F	RESISTANCE Ohms Ω	TEMP °F	RESISTANCE Ohms Ω
60°	139055 Ω	330°	1192 Ω
80°	84644 Ω	335°	1123 Ω
100°	53146 Ω	340°	1058 Ω
120°	34328 Ω	345°	998 Ω
140°	22755 Ω	350°	942 Ω
160°	15446 Ω	355°	890 Ω
180°	10716 Ω	360°	841 Ω
200°	7586 Ω	365°	795 Ω
210°	6427 Ω	370°	752 Ω
220°	5470 Ω	375°	712 Ω
240°	4013 Ω	380°	675 Ω
260°	2991 Ω	385°	640 Ω
280°	2262 Ω	390°	607 Ω
300°	1734 Ω	395°	576 Ω
320°	1347 Ω	400°	547 Ω
325°	1267 Ω		

If the probe returns an open circuit or 0 Ohms reading it should be replaced. If the resistance varies more than 20 Ohms from the above chart when being checked between 325 - 375°F (162°C - 190°C) the probe will give a false temperature reading on the computer and should be replaced. However, it will continue to operate at a slightly higher or lower temperature. Allow the oil to cool and check the probe resistance at a lower temperature. As can be seen from the chart a greater degree of offset can be allowed at a lower temperature.

### Relays:

Relays will energize when the correct voltage is sup-

plied to the coil. When energizing, the relay Switching Contacts will close, thus connecting the Common and Normally Open terminals.

### Hi Limits:

A Hi - Limit switch is a normally closed switch until the temperature at its probe reaches 435°F ± 15° (225°C ± 15°). In order to test this switch it will be necessary to bypass the Heat Demand Relay. This will cause the fryer to heat until the temperature of the oil reaches the necessary temperature to trip the Hi Limit.

#### **WARNING**

Do NOT leave the machine during this test. This test will cause the oil to heat past the normal operating temperature and can cause damage to the machine and its operator. Always use an external temperature probe to observe the oil temperature during this procedure

In order to cause the oil to reach a temperature where the Hi Limit will trip it will be necessary to bypass the Temperature Controls.

If the switch does not trip between the prescribed limits it is defective and should be replaced. Once tripped, the switch cannot be reset until the oil has cooled to approximately 400°F (204°C). If the switch cannot be reset it is defective.

### Drain Valve & Return Valve Switches:

These switches are magnetically operated Reed switches. When the Drain Valve handle is moved to the open position, the Actuator will move away from the switch causing the Reed switch to open. When the Drain Valve is closed the Reed switch will close. This switch can also be checked with an Ohm meter. The normal gap between the Actuator and the Sensor switch on the Drain Valve handle is 1/8" - 1/4" (3 - 6 mm).

### Transformer:

Transformers are multiple input voltage, 24 volt output voltage and can be checked by reading the input and output voltages.

### **Blower:**

Check the voltage between the wires going to the Blower. If 230 VAC is found at the blower connection and the Blower is NOT turning it is defective.

### **Pressure Switch:**

As the blower speed rises the amount of vacuum on the suction side of the pressure switch rises past approximately 1.3" WC (0.325 kPa) and the Pressure Switch will close. When the vacuum falls below approximately 0.8" WC (0.2 kPa) the Pressure Switch will open. With the Blower running, check the IN and OUT voltage of the Switch. If 24 VAC can be found on one side but NOT the other, the Pressure Switch is defective.

### **Ignition Control Modules:**

When the Ignition Control Module is supplied with 24 VAC from the temperature control system at the TH terminal it will send a signal to the Ignitor which will begin to spark. At the same time the Ignition Control Module will also have a 24 VAC output signal on the PV terminal sending 24 VAC to V2. At this time the Low-Fire flame will light and produce a flame sense signal. When the Ignition Control Module is supplied with a flame sense signal it will send a second 24 VAC signal on the MV terminal which will cause the V2 gas valve to open and thus create the Hi-Fire flame. If a flame sense signal is NOT received the Ignition Control Module will spark for 15 seconds before it "Locks Out". If the machine is running on High Fire flame and loses the flame for any reason the Ignition Control will "Lock Out" in 0.8 seconds.

### **Ignitors:**

When an Ignitor is supplied with power and does NOT spark the Spark Gap should be checked. The distance between the Ignitor and the Ground post should be approximately 1/8" ± 1/32".

## **PARTS:**

### **General Parts:**

Basket, #18 .....	P6072184	Module, Ignition Control - 24VAC .....	PP11096
Blower, Variable Speed 240V 50/60HZ.....	PP11091	Motor, Filter Pump - 230V 1 Ph .....	B5304701
Brush, Cleaning .....	PP10056	O-Ring, 0.5" ID .....	PP10111
Burner, Nat Gas .....	B8021001	O-Ring, 0.688 ID x 0.875 OD, Pick Up .....	PP10409
Burner, LP Gas .....	B8021002	O-Ring, 1" ID .....	PP11104
Burner Gasket .....	A8019401	O-Ring, 1.25" ID .....	PP11188
Capacitor, Motor Starting .....	PP11196	O-Ring, 13" ID .....	PP11105
Caster, Swivel .....	PP11113	Orifice, Burner .....	A8002721
Caster, Locking .....	PP11114	Orifice, Main Burner .....	P6071336
Caster, Filter .....	P6071062	Pan Assembly .....	B6645801
Circuit Breaker, 8 Amp Rocker .....	PP10460	Probe, Temperature .....	P5044876
Circuit Breaker, 15 Amp .....	PP11074	Probe, Ignition/Flame Sensor .....	PP11100
Circulation Tube Assembly .....	B6651001	Pump, Gear Oil w/relief valve .....	B6646301
Clamp, Filter Bag .....	B6646701	Pump Selector Rod .....	A4018602
Computer .....	PP11235	Pump Strainer .....	B6646601
Contactora, Motor Starting - 24VAC .....	PP11102	Rack, Tube .....	B4511301
Controller Digital T-Stat .....	PP11082	Regulator, Gas Pressure .....	PP11093
Controller, Fan - 2 Speed .....	PP11099	Relay, 24 VAC DPDT .....	P5046686
Door Assembly - RH .....	B2302501	Relay, 24 VDC SPDT .....	PP11124
Door Assembly - LH.....	B2302502	Relay DPDT-24VDC .....	PP11068
Drain Fitting Screen.....	B3319601	Relay, Over Load .....	PP11103
Filter, Air.....	PP11072	Retainer, Filter Bag.....	B6652701
Filter Bags (64 Count) .....	A7011101	Screen Assembly, Filter Pickup .....	B6646501
Filter Removal Tool .....	A4018002	Skimmer, Mesh .....	PP10725
Flush Hose Assembly .....	B6602501	Snap Ring, Pick Up Tube.....	PP10842
Gasket .....	A8019401	Spider Bushing .....	PP11080
Gauge, Pressure .....	PP11223	Spider Coupling .....	PP11089
Gauge, Vacuum .....	PP11073	Strainer, Pump .....	B6646601
Handle Assy, Drain Valve .....	B4002201	Switch, Motor Starter .....	PP11195
Handle, Door .....	P6071516	Switch, Off/On/Start .....	PP10559
Handle, Flush Hose Assembly.....	B4002501	Switch, Pressure Sensing .....	PP10925
Handle, Pump Inlet Selector .....	B4002701	Switch, Proximity Actuator .....	PP10263
Handle, Filter Bag Removal .....	A4018002	Switch, Proximity Sensor .....	PP10262
Hanger, Basket.....	A1105002	Tank Assembly.....	B3319101
Harness, Control Cable.....	B6733001	Tape, Heat 240VAC .....	PP10298
Hinge, Door - Bottom Left .....	PP10895	Tape, Heat 240 VAC 165 Watt - 1/2" x 79" .....	PP10080
Hinge, Door - Bottom Right .....	PP10896	Tape, Heat 240 VAC - 48" .....	PP10588
Hinge, Door - Top Left .....	PP10893	Thermostat, Alternate .....	P5047587
Hinge, Door - Top Right .....	PP10894	Thermostat, Snap Disk .....	PP10739
Hi Limit- Snap Disc - 425 Deg .....	PP11064	Transformer, 230 - 24 VAC.....	PP10429
Holder, Filter Bag .....	B6646901	Tube Assembly, Pickup.....	B6646401
Hose, fluoropolymer.....	B6647501	Tube, Recirculation.....	B6651001
Hose, Flush .....	B6602405	Tube Rack .....	B4511301
Insulator, O-Ring Fitting .....	A7005601	Valve 3/8" W/O Handle .....	P6071780
Knob, Thermostat .....	PP10539	Valve, Drain .....	P6071769
Knob, Plastic, 1" .....	PP11218	Valve, Gas 1" -24VAC NAT/LP .....	PP11092
Main O-Ring Fitting .....	B6646801	Valve, Gas Poppet.....	PP11094
		Valve, Manual Shut Off .....	PP11095
		Vibration Pad .....	A7010701
		Vibration Washer .....	A7010801
		Wire, Ignition with Boot .....	PP11200

**Entrance Box Assembly:**

#	DESCRIPTION	PART #
1	Cover, Top .....	A2951601
2	Cover, Rear .....	A2951701
3	Body .....	A2951801
4	Guide, Air Filter .....	A2951901
5	Bracket, Blower Mounting .....	A2952001
6	Bracket, Relay Mounting .....	A2952101
7	Slide, Air Filter .....	B2911301
8	Plate, Front .....	A2952301
9	Cover, Air Filter Access .....	A2952401
10	Tray, Component Mounting .....	A2952501
11	Cover, Component Access .....	A2952601
12	Blower .....	PP11091
13	Air Filter .....	PP11072
14	Handle .....	P6071516
15	Switch, Rocker - SPDT .....	PP10093
16	Contact, 24 VAC 3 pole .....	PP10560
17	Circuit Breaker, Control - 8 A, 250 VAC .....	PP10460
18	Heater, Overload Relay .....	PP11103
19	Contact, Motor Starter .....	PP11102
20	Relay - DPDT, 10A 24 VDC .....	PP11068
21	Relay - DPDT, 24 VAC .....	P5046686
22	Ignition Control Module .....	PP11096
23	Clamp, Ground .....	P5045241
24	Circuit Breaker, Master - DPST 250 VAC .....	PP11074
25	Switch, Pressure .....	PP10925
26	Bushing, Strain Relief .....	PP10914
27	Lamp, 28 V Amber .....	P5045044
28	Transformer, 80 VA Multi Tap to 24 .....	PP10429
29	Control, 2 Speed Fan .....	PP11099
30	Label, Switch Cover .....	A6071501
31	Wiring Harness .....	B6727401
32	Nutsert, 10-24 .....	P0092500
33	Nutsert, 6-32 .....	P0091400
34	Screw, 6-32 x 5/16" .....	PP10687
35	Screw, 6-32 x 7/8" .....	P0006100
36	Screw, 10-24 x 3/8" .....	PP10693
37	Screw, 10-32 x 1/2" .....	PP10752
38	Switch, Pump Motor Starter .....	PP11195
39	Capacitor, Pump Motor Starter .....	PP11196
40	Ignition Wire .....	PP11200
41	Screw, M4 .....	PP10303
42	Clip, Spring .....	PP11234
43	Connector, Plug 5 Pin .....	PP11098
44	Adaptor, Ignition Wire .....	PP11263

NOTES:

- CONNECTOR J8 IS SUPPLIED WITH M2, CONNECTOR J5 IS SUPPLIED WITH A1 AND CONNECTOR J12 IS SUPPLIED WITH A2.
- ALL WIRES TO BE 18 GAUGE UNLESS OTHERWISE SPECIFIED.

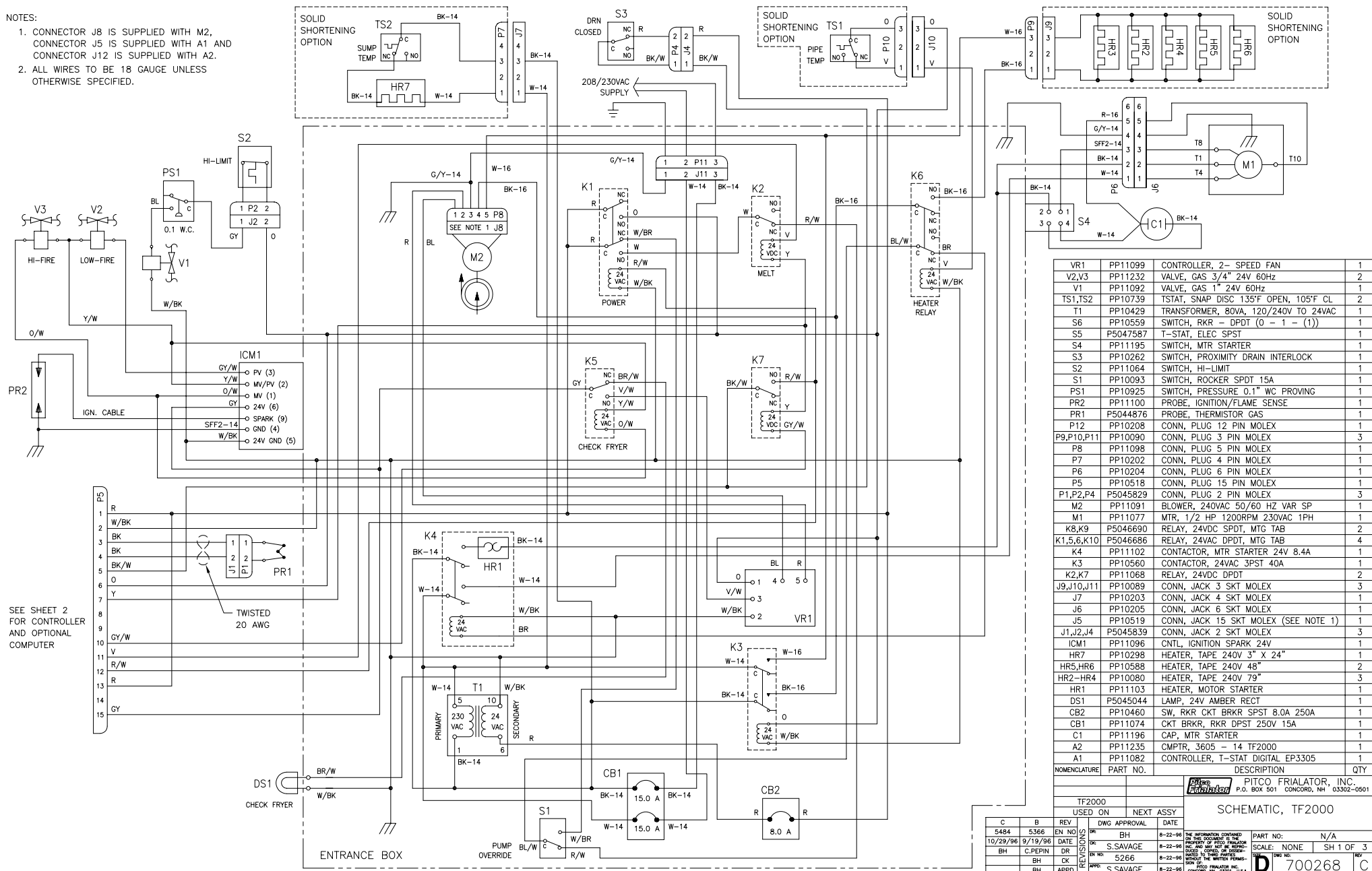

VR1	PP11099	CONTROLLER, 2- SPEED FAN	1	
V2,V3	PP11232	VALVE, GAS 3/4" 24V 60Hz	2	
V1	PP11092	VALVE, GAS 1" 24V 60Hz	1	
TS1,TS2	PP10739	TSTAT, SNAP DISC 135°F OPEN, 105°F CL	2	
T1	PP10429	TRANSFORMER, 80VA, 120/240V TO 24VAC	1	
S6	PP10559	SWITCH, RKR - DPDT (0 - 1 - (1))	1	
S5	P5047587	T-STAT, ELEC SPST	1	
S4	PP11195	SWITCH, MTR STARTER	1	
S3	PP10262	SWITCH, PROXIMITY DRAIN INTERLOCK	1	
S2	PP11064	SWITCH, HI-LIMIT	1	
S1	PP10093	SWITCH, ROCKER SPDT 15A	1	
PS1	PP10925	SWITCH, PRESSURE 0.1" WC PROVING	1	
PR2	PP11100	PROBE, IGNITION/FLAME SENSE	1	
PR1	P5044876	PROBE, THERMISTOR GAS	1	
P12	PP10208	CONN, PLUG 12 PIN MOLEX	1	
P9,P10,P11	PP10090	CONN, PLUG 3 PIN MOLEX	3	
P8	PP11098	CONN, PLUG 5 PIN MOLEX	1	
P7	PP10202	CONN, PLUG 4 PIN MOLEX	1	
P6	PP10204	CONN, PLUG 6 PIN MOLEX	1	
P5	PP10518	CONN, PLUG 15 PIN MOLEX	1	
P1,P2,P4	P5045829	CONN, PLUG 2 PIN MOLEX	3	
M2	PP11091	BLOWER, 240VAC 50/60 HZ VAR SP	1	
M1	PP11077	MTR, 1/2 HP 1200RPM 230VAC 1PH	1	
K8,K9	P5046690	RELAY, 24VDC SPDT, MTG TAB	2	
K1,5,6,K10	P5046686	RELAY, 24VAC DPDT, MTG TAB	4	
K4	PP11102	CONTACTOR, MTR STARTER 24V 8.4A	1	
K3	PP10560	CONTACTOR, 24VAC 3PST 40A	1	
K2,K7	PP11068	RELAY, 24VDC DPDT	2	
J9,J10,J11	PP10089	CONN, JACK 3 SKT MOLEX	3	
J7	PP10203	CONN, JACK 4 SKT MOLEX	1	
J6	PP10205	CONN, JACK 6 SKT MOLEX	1	
J5	PP10519	CONN, JACK 15 SKT MOLEX (SEE NOTE 1)	1	
J1,J2,J4	P5045839	CONN, JACK 2 SKT MOLEX	3	
ICM1	PP11096	CNTL, IGNITION SPARK 24V	1	
HR7	PP10298	HEATER, TAPE 240V 3" X 24"	1	
HR5,HR6	PP10588	HEATER, TAPE 240V 48"	2	
HR2-HR4	PP10080	HEATER, TAPE 240V 79"	3	
HR1	PP11103	HEATER, MOTOR STARTER	1	
DS1	P5045044	LAMP, 24V AMBER RECT	1	
CB2	PP10460	SW, RKR CKT BRKR SPST 8.0A 250A	1	
CB1	PP11074	CKT BRKR, RKR DPST 250V 15A	1	
C1	PP11196	CAP, MTR STARTER	1	
A2	PP11235	CMPTIR, 3605 - 14 TF2000	1	
A1	PP11082	CONTROLLER, T-STAT DIGITAL EP3305	1	
NOMENCLATURE		PART NO.	DESCRIPTION	QTY

PITCO FRIALATOR, INC.  
P.O. BOX 501 CONCORD, NH 03302-0501

TF2000 SCHEMATIC, TF2000

C	B	REV	EN	NO	DATE	BY	APPD	DATE	DESCRIPTION	PART NO.	SCALE	SH	OF	REV
5484	5366		EN	NO	8-22-96	BH		8-22-96	The information contained on this drawing is the property of Pitco Frialator, Inc. and may not be reproduced in any form without the written permission of Pitco Frialator, Inc.	N/A	NONE	1	OF 3	
10/29/98	5/19/98		DR	NO	8-22-96	S.SAVAGE		8-22-96						
BH			DR	NO	8-22-96	S.SAVAGE		8-22-96						
			CK	NO	8-22-96	5266		8-22-96						
			APPD	NO	8-22-96	S.SAVAGE		8-22-96						

DWG NO: 700268

SEE SHEET 2 FOR CONTROLLER AND OPTIONAL COMPUTER

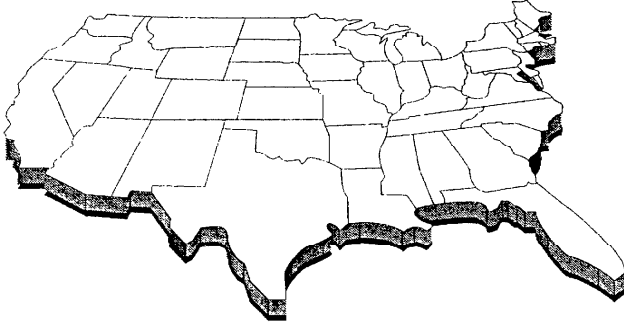

In the event of problems with or questions about your equipment, please contact your local ASAP (Authorized Service and Parts) representative. You can find their number by calling the:

**NATIONAL SERVICE COOPERATIVE**  
**1(800)298-1862**

**To obtain copies of this Installation, Operators and Maintenance Manual at NO CHARGE please contact Pitco Frialator at the following address:**

**Pitco Frialator Inc.,**  
P.O. BOX 501  
CONCORD, NH 03302-0501

In the event of problems with or questions about your order, please contact the Pitco Frialator factory, from 8:00 a.m. - 5:00 p.m., Eastern Standard Time, Monday through Friday,

(603)225-6684 World Wide