

Pitco Frialator

Installation, Operation and
Maintenance Manual

for the

TURBOFRY 2000

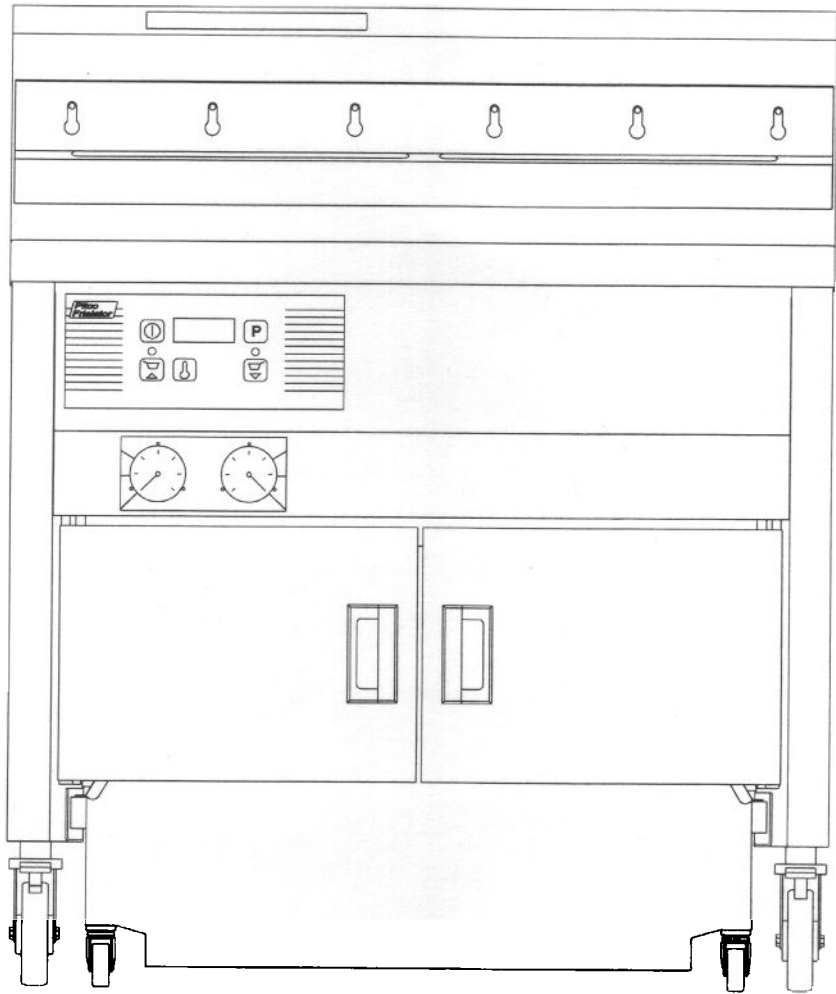



FOR YOUR SAFETY:

Do not store gasoline or other flammable vapors or liquids in the vicinity of this or any other appliance.

TO THE PURCHASER

POST IN A PROMINENT LOCATION INSTRUCTIONS TO BE FOLLOWED IN THE EVENT THAT AN OPERATOR SMELLS GAS. OBTAIN THIS INFORMATION FROM YOUR LOCAL GAS SUPPLIER.

WARNING:

IMPROPER INSTALLATION, ADJUSTMENT, ALTERATION, SERVICE OR MAINTENANCE CAN CAUSE PROPERTY DAMAGE, INJURY OR DEATH. READ THE INSTALLATION, OPERATING AND MAINTENANCE MANUALS THOROUGHLY BEFORE INSTALLING OR SERVICING THIS EQUIPMENT.

WARNING

This appliance is equipped with a three prong (grounding) plug. This is for your protection against shock hazard in the event of equipment malfunction. Always plug the unit into a properly grounded three-prong receptacle. **DO NOT** cut or remove the grounding (third) prong.

WARNING

DO NOT use an open flame to check for gas leaks! Keep all open flames away from the machine at all times.

WARNING

Machines equipped with casters and a flexible power cord, must be connected to a gas supply with a Quick-Disconnect device. This quick disconnect must comply with ANSI Z24.41. To limit the movement of the unit without depending on the connector or quick disconnect, a restraining cable must also be installed.

WARNING

There is an open flame inside the machine. The unit may get hot enough to set nearby materials on fire. Keep the area around the unit free from combustibles.

WARNING

Use only a B/C or A/B/C extinguisher that contains the dry chemical Sodium Bicarbonate or Potassium Bicarbonate should be used to extinguish any fires.

WARNING

Ensure that the machine can get enough air to keep the flame burning correctly. If the flame is starved of air it can give off a dangerous carbon monoxide gas. Carbon Monoxide is a clear odorless gas that can cause suffocation.

WARNING

Carbon Monoxide gas can build up if you obstruct the flue. Blocking the flue will also cause the unit to overheat. **DO NOT** obstruct the flow of combustion/ventilation or air opening around the machine. Ensure that you meet the minimum clearances specified in the installation instructions. Adequate clearance around the unit is necessary for servicing and proper burner operation.

WARNING

If the machine should shut down unexpectedly wait 5 minutes before attempting to restart it. This will allow for any excess gas in the unit to dissipate.

WARNING

The power supply must be disconnected before servicing or cleaning the unit.

WARNING

DO NOT supply the fryer with a gas that is not identified on the data plate, located on the inside of one of the doors of the machine. If you need to convert the machine to another type of fuel, contact your dealer or Authorized Blodgett Service Agency.

WARNING

To prevent tipping of the machine and splashing of HOT oil your Pitco Frialator fryer is equipped with a Gas Hose Quick Disconnect and restraining device. This attaches the rear of the machine to the wall. When the fryer is in its operating location, lock the casters and reattach the restraining device to the rear of the machine.

WARNING

Shortening, when it is at cooking temperatures, is very HOT and DANGEROUS! Use extreme caution when handling! Use the proper protective gear such as insulated gloves, aprons, face shield and sleeves when handling hot shortening. **DO NOT** attempt to move any machine that has hot oil in it. Allow the oil to cool to room temperature or drain the oil into a suitable container before moving the fryer.

ORIGINAL EQUIPMENT LIMITED WARRANTY - TURBOFRY 2000

General Warranty

Pitco Frialator, Inc. warrants to the original user of its Turbofry 2000 cooking appliance that said appliance and related equipment will be free from defects in material and workmanship under normal use for a period of one (1) year from the date of installation, with appropriate documentation, subject to the following additions, exceptions, exclusions and limitations.

What is covered

This warranty is limited to the repair or replacement at the Company's option, without charge, of any part found to be defective within the warranty period and reasonable expenses incurred for freight and material for the installation of such part; in addition, the Company's obligation shall be limited to reimbursement for normal labor on such parts.

Pitco Frialator, Inc. agrees to pay the G.S. Blodgett Corporation Authorized Service and Parts Distributor, for any labor and material required to repair or replace, at the Company's option, any part which may fail due to defects in material or workmanship during the above general warranty period.

Fry Tanks

In addition, the Company warrants to the original user of any fry tank to be free from defects for a period of ten (10) years from the date of manufacture. Labor and freight shall be the responsibility of the user. This shall only obligate the Company to repair or replace, at its option, any fry tank which it determines to be defective. Claims under this item shall be supported by a statement detailing the defect, and the Company may require the return of the fry tank claimed to be defective.

Computer or Digital Cooking Controller

In addition, the Company warrants to the original user of any Cooking Computer or Digital Controller to be free from defects for a period of two (2) years from the date of manufacture. During the two (2) year period all charges involved in the replacement of a Pitco Computer or Digital Controller will be the responsibility of Pitco Frialator Inc.

How to Keep Your Warranty in Force

- Make sure any shipping damages are reported immediately. Damages of this nature are the responsibility of the carrier.
- Install the unit properly. This is the responsibility of the installer and the procedures are outlined in the manual. Do not install it in a home or residence.
- Maintain the unit properly. This is the responsibility of the user, the procedures are outlined in the manual.

What is NOT covered under this Warranty

- Adjustments, such as calibration, leveling, tightening of fasteners or plumbing or electrical connections normally associated with initial installation are not covered under this warranty. These procedures are outlined in the installation manual.
- Damaged due to flood, fire or other acts of Nature are not covered under this warranty.
- If the unit is used for a purpose other than for which it was intended or designed, resulting damages are not covered under the warranty.
- Failures due to erratic voltage or gas supplies are not covered under the warranty.
- Material alterations or modifications from the condition in which the unit left the factory are not covered under the warranty.
- Units with unreadable, obliterated or removed serial number rating plates are not covered by the warranty.
- Any parts other than Genuine OEM parts from Pitco Frialator, Inc. or its Authorized Parts and Service Distributors are not covered by the warranty.
- Any other failure which is not attributable to a defect in materials or workmanship is not covered by the warranty.

This warranty specifically excludes parts which wear or would be replaced under normal usage, including, but not limited to, electric lamps, fuses, interior or exterior finishes and gaskets.

Limits to the Warranty

Outside the United States of America and Canada, this warranty is limited to the replacement of parts and Pitco Frialator, Inc. will not bear any other expense be it labor, mileage, freight or travel.

Charges for mileage over one hundred (100) miles, travel time over two (2) hours, overtime, and holiday charges are not covered under this warranty. These charges are the responsibility of the individual or firm requesting these services.

If any oral statements have been made regarding the appliance, these statements do not constitute warranties and are not part of the contract of sale. This limited warranty constitutes the complete, final and exclusive statement with regard to warranties.

THIS LIMITED WARRANTY IS EXCLUSIVE AND IS IN LIEU OF ALL OTHER WARRANTIES WHETHER WRITTEN, ORAL OR IMPLIED, INCLUDING, BUT NOT LIMITED TO ANY WARRANTY OF MERCHANTABILITY OR FITNESS FOR A PARTICULAR PURPOSE OR WARRANTY AGAINST LATENT DEFECTS.

Limitations of Liability

In the event of a warranty or other claim, the sole obligation of Pitco Frialator, Inc. will be the repair or replacement, at the Company's option, of the appliance or the component part. This repair or replacement will be at the expense of Pitco Frialator, Inc. except as limited by this warranty statement. Any repair or replacement under this warranty does not constitute an extension in time to the original warranty. Parts covered under this warranty will be repaired or replaced, at the Company's option, with new or functionally operative parts. The liability of Pitco Frialator, Inc. on any claim of any kind, including claims based on warranty, express or implied contract, negligence, strict liability or any other legal theories will be exclusively the repair or replacement of the appliance. This liability will not include, and the purchaser specifically renounces any right to recover special, incidental, consequential or other damages of any kind, including, but not limited to, injuries to persons, damage to property, loss of profits or anticipated loss of the use of this appliance.

If any provision of this warranty is unenforceable under the law of any jurisdiction, that provision only will be inapplicable there, and the remainder of the warranty will remain unaffected. The maximum exclusion or limitation allowed by law will be substituted for the unenforceable provision.

How to Obtain Warranty Service

First direct your claim to the G.S. Blodgett Corporation Authorized Service and Parts Distributor closest to you giving complete model, serial and code numbers, voltage, gas type, and description of the problem. Proof of the date of installation and/or the sales slip may also be required. If this procedure fails to be satisfactory, write the National Service Manager, Pitco Frialator, Inc., P. O. Box 501, Concord, NH. 03302-0501. USA

This warranty gives you certain specific legal rights; you may have other rights which vary from state to state.

Table of Contents

ORIGINAL EQUIPMENT LIMITED WARRANTY	ii
INTRODUCTION	1
Chapter 1: DELIVERY and UNPACKING	1
Checking your new fryer	1
Check Your Order	2
Chapter 2: INSTALLATION	2
Installation Clearances	2
Gas Connection	2
Fuel Types	3
Gas Line Connection	3
Quick Disconnect Gas Connection	3
Fuel Supply Line Leak and Pressure Testing	3
Electrical Connection and Requirements	3
Ventilation and Fire Safety Systems	4
Visual Checks	4
Initial Cleaning	4
Chapter 3: OPERATING INSTRUCTIONS	5
Component Recognition - Fry Tank	5
Component Recognition - Controls	6
Morning Fryer Start Up	7
Fryer Shut Down	8
Operating the Digital Controller	9
Programming the Digital Controller	9
Operating the Computer Control	10
Programming the Cook Time, Shake Time and Hold Times	10
Programming Cooking Temperature	10
Level 2 Programming	10
Main Filter Bag Changing Procedures	12
Flush Hose Operation	13
Chapter 4: PREVENTATIVE MAINTENANCE	13
Daily Cleaning	13
Weekly Cleaning	13
Vacuum Gauge Inspection	14
Boil Out Procedure	14
Air Filter Inspection	16
Inspect O-Rings	16
Service Technician Inspection	17
Storing the Turbofry 2000	17
Returning the Turbofry 2000 to service after storage	17
Chapter 5: PARTS	18
Chapter 6: TROUBLESHOOTING	19

INTRODUCTION

The development of the TURBOFRY 2000 fills the needs of the food industry that have been, until now, unattainable. They are:

1. Continuous filtration of the food oil.
2. Crispier than ever fried food coatings due to convection currents.
3. High production from a high efficiency heat transfer system.

Continuous filtration of the cooking oil provides clean, clear oil, even through busy periods. This means breaded particles do not settle on heating surfaces and burn, which in turn means longer oil life and lower oil costs. The clean oil produces foods with coatings free of burnt food particles that look and taste more appetizing. Turbofry 2000 has an advanced filter system that makes clean up quick and easy. The main filters trap the larger crumbs and can be lifted out for easy cleaning and replacement.

The Turbofry 2000 uses a heating process, within the cooking area, known as "Convection", foods cook with crisper coatings because hot oil is forced between the individual pieces of food, the breading or outer coating gets seared quickly before the food can absorb as much oil as with a standard fryer. This will produce a finished product that is much lower in absorbed oils.

The Turbofry 2000 has a high efficiency gas combustion system that transfers heat more efficiently than regular fryers. The high input rate in conjunction with a large heat transfer surface area give this fryer the ability to cook high capacity loads effortlessly.

Chapter 1: DELIVERY and UNPACKING

Checking your new fryer:

Your new fryer and it's filter have been carefully packed. Every effort has been made to ensure that your fryer will be delivered to you in perfect condition. As you unpack your new fryer, inspect each of the pieces for damage. If something is damaged, DO NOT sign the bill of lading. Contact the shipper immediately, the shipper is only responsible for 15 days after delivery. Check the packing list enclosed with your fryer to ensure that you have received all of the parts to the fryer. If you are missing any parts, contact the dealer from whom the fryer was purchased. As you unpack the fryer and it's accessories be careful to keep the weight of the fryer evenly distributed.

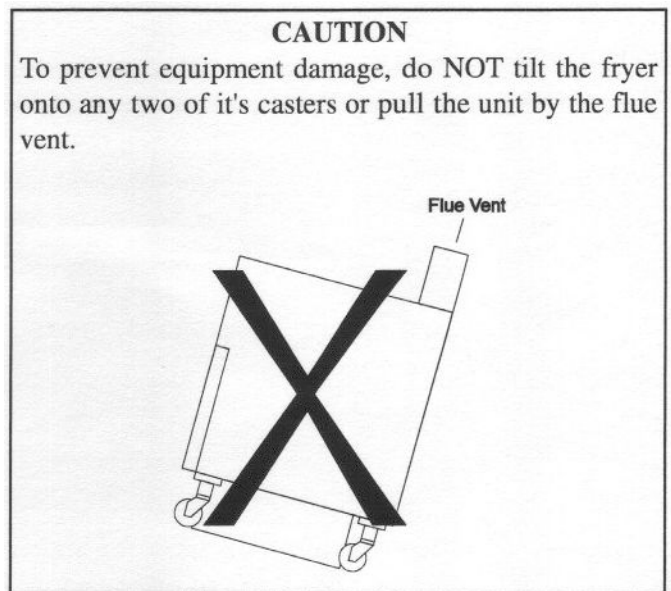

Locate the data plate on the inside panel of the door, record the model and serial number, date received and date installed in the space provided below.

Model Number: _____
(Example: TF2000)

Serial Number: _____
(Example: G96AB12345)

Date Recieved: _____

Date Installed: _____

Check Your Order:

The crate containing the fryer unit will also contain the following:

- 4 - Fry baskets P6072184
- 1 - Fry Basket Hanger A1105002
- 4 - Pitco Cleaner Sample P6071400
- 1 - Drain Clean Out Rod A3333401
- 1 - Flush Hose B6602501
- 1 - Cleaning Brush (Fryer) PP10056
- 1 - Filter Crumb Scoop B7404801
- 16 - Filter Bags A7011101
- 1 - Filter Bag Removal Tool A4018002
- 1 - Drain Fitting Screen B3319601
- 1 - Skimmer PP10725

Chapter 2: INSTALLATION

Although it is possible for you to install and set up your new fryer, it is **STRONGLY** recommended that you have it done by qualified professionals. The professionals that install your new fryer will know the local building codes and ensure that your installation is safe.

WARNING

The fryer must be properly restrained to prevent movement or tipping. This restraint must prevent the fryer from movements that would splash hot liquids on personnel. This restraint may be any means (alcove installation, adequate cable restraint or battery installation).

Installation Clearances:

The fryer needs clearance around it for proper operation. Adequate clearances allow for servicing and proper burner operation. The clearances shown below are for cooker installation in combustible and noncombustible construction.

	Combustible Construction	Non-Combustible Construction
Back	3" (8 cm)	3" (8 cm)
Sides	3" (8 cm)	0" (0 cm)

In addition to the clearances required for proper fryer operation, there must be at least 33" (84 cm) of aisle space in front of the fryer to remove/install the filter pan/module.

Gas Connection:

Your fryer must be plumbed with a 3" drip leg. The size of the gas hose, gas line and quick disconnect must be sufficiently large enough to provide at least 250,000 BTU/HR gas flow. The gas line must be installed to meet the local building codes or National Fuel Gas Code (NFPA 54-1984) and ANSI Z223.1-1988 Latest Edition. In Canada, install the fryer in accordance with CAN/CGA-B149.1 or .2 and local codes. Gas line sizing requirements can be determined by your local gas company by referring to National Fuel Gas Code, Appendix C, Table C-4 (natural gas) and Table C-16 (propane). The gas line needs to be large enough to supply the necessary amount of fuel to all appliances without losing pressure to any appliance. Other factors that are used to determine the piping requirements are BTU requirements of the appliances being connected and the length of pipe between the meter (main shut off) and the appliances.

WARNING

NEVER supply the fryer with a gas that is not indicated on the data plate. Using the incorrect gas type will cause improper operation. If you need to convert the fryer to another type of fuel, contact your dealer.

Fuel Types:

Each fryer is equipped to work with one type of fuel. Each Turbofry 2000 is set at the factory and should need no further adjustments. Refer to the data plate, located on the inside of the door, for the gas specifications of the machine you have. Attach a water manometer to the pressure port on the manual gas valve shown.

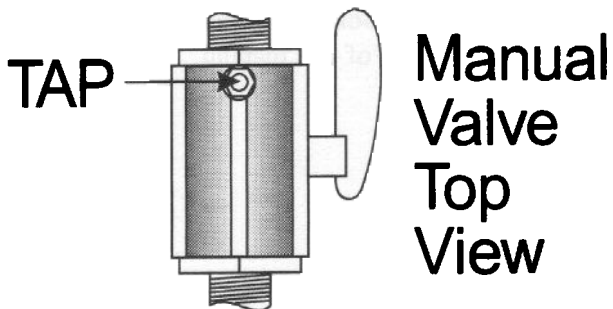

Check that the INPUT SUPPLY PRESSURE is 5 - 13" WC for Natural Gas and 10 - 13" WC for LP gas.

WARNING

DO NOT use an open flame to check for gas leaks!

Gas Line Connection:

Connect the fryer to the gas supply line with a connector that complies with the Standard for Connectors for Movable Gas Appliances (ANSI Z21.69-1987). Connect the gas line to the fryer using a pipe joint sealant that is resistant to Liquefied Petroleum. If the fryer was disconnected during the fuel line testing, use a solution of soap and water to leak test the new connection. It is advised that the gas supply to the fryer be connected to the ventilation system in such a way as to prevent the fryer from being operated without the ventilator on.

CAUTION

NEVER use an adaptor to make a smaller gas supply line fit the cooker connection. This will not allow sufficient gas flow for optimum burner operation, resulting in poor cooker performance.

Quick Disconnect Gas Connection:

The Turbofry 2000 is supplied with casters and must be installed with a gas connector that comply with the Standard for Connectors for Movable Gas Appliances, ANSI Z21.69-1987, and Addenda Z21.69A-1989. This connection should include a quick disconnect device that complies with the Standard for Quick Disconnect Devices for Use With Gas Fuel, ANSI Z21.41-1989.

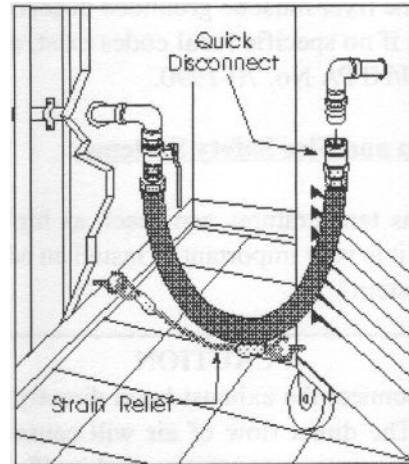

When installing a quick disconnect you must also install a means for limiting the movement of the fryer. This device will prevent the gas line or the quick disconnect from being strained. The restraining device should be attached to the cooker on the back panel as shown in the illustration. The quick disconnect, hose, and restraining device is supplied with all Pitco Frialator Turbofry 2000 fryers systems.

Fuel Supply Line Leak and Pressure Testing:

The fuel supply system must be tested before the fryer is used. If the fuel line is going to be tested at a pressure greater than (>)1/2 PSI (3.45 kPa), make sure that the fryer is disconnected from the fuel line. If the fuel line is to be tested at a pressure equal to or less than (≤) 1/2 PSI (3.45 kPa), the fryer can be connected but the unit's gas valve must be shut. Test all gas line connections for leaks with a solution of soap and water when pressure is applied.

Electrical Connection and Requirements:

The electrical service used by the fryer must comply with local codes. If there are no local codes that apply, refer to the National Electrical Code (NEC) to install the service. In Canada refer to CSA Standard C22.1 and local codes.

Wiring diagrams are provided inside the fryer control box. The power requirements for the fryer are shown below.

Voltage	208/230 VAC, 60Hz
Amps	2.8 -3.5 Amps
Branch Circuit Protector	20.0 Amps

The fryer is supplied with an 8' power cord for the fryer controls and the filter. As the unit is supplied on casters, a quick disconnect electrical connector (plug) is recommended. The fryer must be grounded in accordance with local code; if no specific local codes exist, comply with NEC ANSI/NFPA No. 70-1990.

Ventilation and Fire Safety Systems:

Exhaust gas temperatures can reach as high as 600°F. Therefore, it is very important to install an adequate fire fighting system.

CAUTION

NEVER connect the exhaust hood directly to the flue opening. The direct flow of air will cause poor temperature recovery, poor ignition and inefficient operation of the fryer.

It is advised that the power supply NOT be controlled by the ventilation control.

Frequent cleaning of the ventilation system and the fryer will reduce the chances of fire.

Additional information can be obtained from the American Gas Association, 8501 East Pleasant Valley Road, Cleveland, OH 44131.

Visual Checks.

Before you begin filling and operating the fryer, perform the following visual checks:

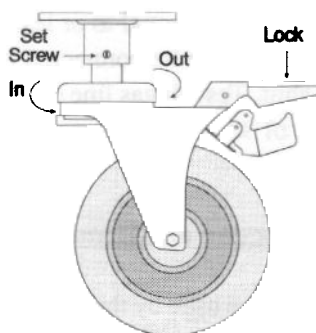

- After the fryer is in its permanent location, lock the casters and check that it is level. Any leveling that is

necessary can be performed by loosening the two set screws on the shaft of the caster, adjust the casters up or down as needed by unscrewing or screwing the wheel in or out. Tighten the locking screws when finished.

- Check that the Oil Circulation Tube is installed correctly.

Initial Cleaning:

Before packaging and shipping, your fryer was thoroughly tested using a Kosher Peanut Oil (a record of this may be obtained from the factory). This oil and any debris that has accumulated between Pitco and the machine's destination must now be removed from the fryer. Follow the instructions for the **Boil Out** procedure outlined in the maintenance section of this manual.

Chapter 3: OPERATING INSTRUCTIONS.

Component Recognition - Fry tank:

The Turbofry 2000 uses a new frying and filtering technology, therefore it is important that you become familiar with the major components inside and outside of the fry tank. The following drawing and index shows these components and their uses:

1. Flue opening - The HOT exhaust gases from combustion will rise from this opening.
2. Burner Heat Tube - Combustion takes place within this tube. The heat radiates out from this tube and from the sides of the fry tank.
3. Hi Limit Probe - The Hi Limit is the safety device that will shut the machine down should the temperature become excessively high.
4. Temperature Sensing Probe - This probe is used by the Digital/Computer Control to sense the actual temperature of the oil.
5. Oil Circulation Tube Assembly - The filtered oil is returned to the fry tank through this tube. It has many orifices along the underside to direct the oil streams into the bottom of the fry tank. There is a handle welded to the end of the tube.
6. Filter Bag Retainers - The Filter Bags "Hang" on the retainer which fits snugly in the Filter Bag Housing.
7. Drain - Oil will drain from this opening when the Drain Valve Handle is operated.
8. Filter Bag Housing Lifting Points - Use the supplied lifting tool to lift the Housing out.

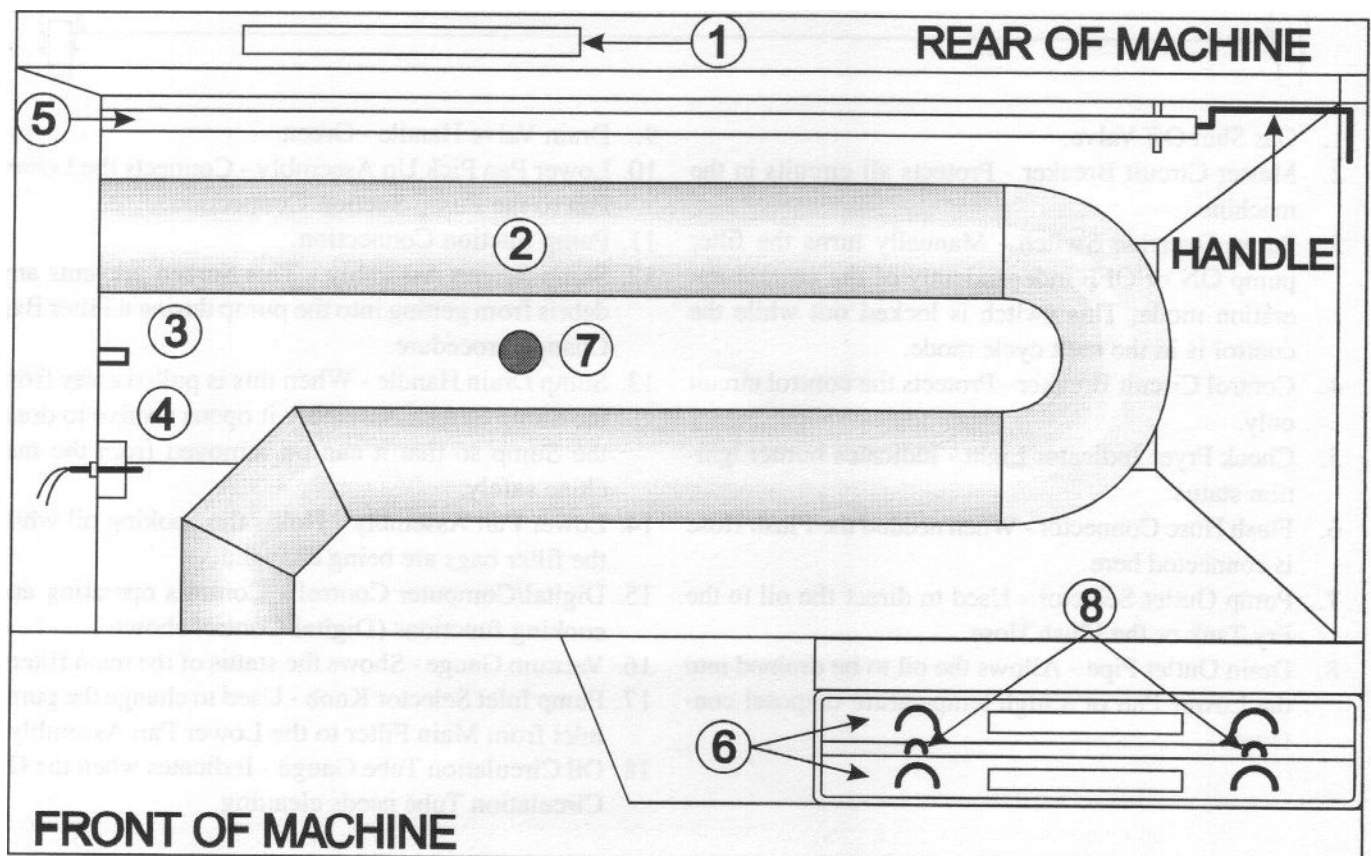

Component Recognition Controls:

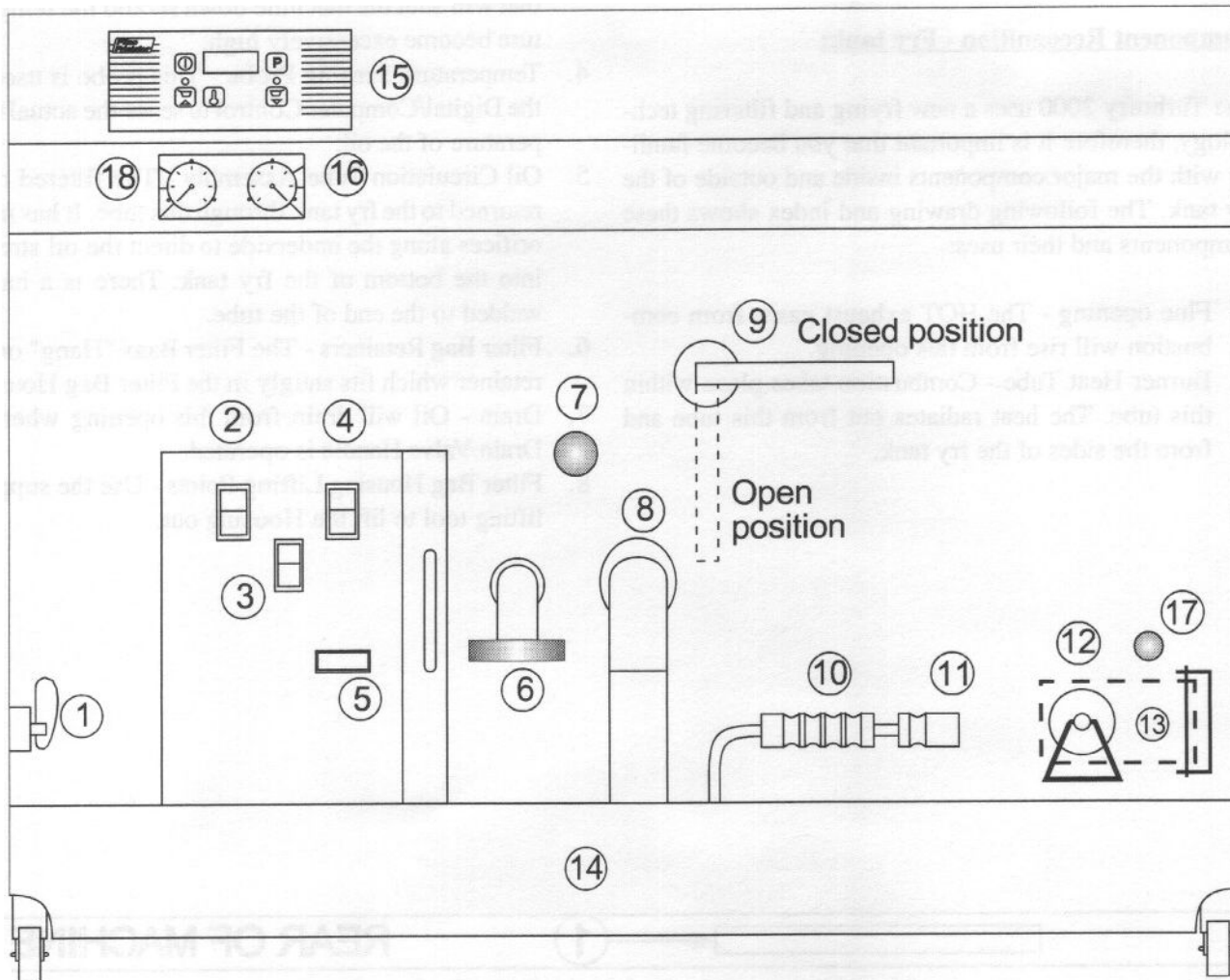

1. Gas Shut Off Valve.
2. Master Circuit Breaker - Protects all circuits in the machine.
3. Pump Override Switch - Manually turns the filter pump ON or OFF independently of the current operation mode. This switch is locked out while the control is in the melt cycle mode.
4. Control Circuit Breaker - Protects the control circuit only.
5. Check Fryer Indicator Light - Indicates burner ignition status.
6. Flush Hose Connector - When needed the Flush Hose is connected here.
7. Pump Outlet Selector - Used to direct the oil to the Fry Tank or the Flush Hose.
8. Drain Outlet Pipe - Allows the oil to be drained into the Lower Pan or a high temperature disposal container.
9. Drain Valve Handle - Green.
10. Lower Pan Pick Up Assembly - Connects the Lower Pan to the Pump Suction Connection.
11. Pump Suction Connection.
12. Sump Screen Assembly - This Screen prevents any debris from getting into the pump during a Filter Bag Change procedure.
13. Sump Drain Handle - When this is pulled away from the Sump Screen Assembly it opens a valve to drain the Sump so that it can be removed from the machine safely.
14. Lower Pan Assembly - Holds the cooking oil while the filter bags are being changed.
15. Digital/Computer Control - Controls operating and cooking functions (Digital Control shown.)
16. Vacuum Gauge - Shows the status of the main filters.
17. Pump Inlet Selector Knob - Used to change the pump inlet from Main Filter to the Lower Pan Assembly.
18. Oil Circulation Tube Gauge - Indicates when the Oil Circulation Tube needs cleaning.

Morning Fryer Start Up:

Your fryer has been constructed to utilize either Liquid or Solid shortening. DO NOT attempt to use Solid shortening in a machine that is NOT equipped with the Solid Shortening option. There is a label located behind the door that will show the type of shortening the machine was designed to use. A fryer designed for Solid shortening can use Liquid shortening, however a fryer designed for Liquid shortening cannot be used for Solid shortening.

Follow the instructions that are appropriate for the type of shortening you are using:

Liquid Oil:

Always observe the safety instructions outlined in the front of this manual before operating this fryer. Because fryer operation is controlled by the Digital or Computer Control Start Up and Shut Down is made very simple.

Make sure the Master (#2, page 6) and Control Circuit Breakers (#4, page 6) are ON by pressing them to the ON position.

Pump any oil from the Lower Pan into the Fry Tank. (See steps 17, 18 & 19 on pages 12 & 13 for instructions on how to do this.) Add sufficient new oil to bring the oil level up to the indicated level. Follow the instructions below to fill the fryer with oil.

Make sure the drain valve is completely closed.

Fill the fryer with oil up to ½" below the "Oil Level" line as shown in the picture below.

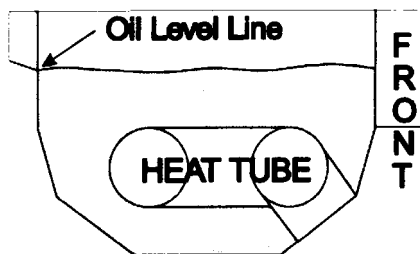

5. Turn the Gas Shut Off Valve handle clockwise to turn the gas ON.

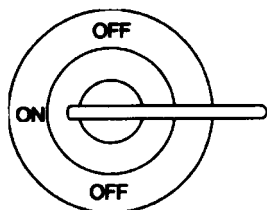





On a fryer equipped with a Computer controller the fryer will now come on and take control of heating the oil. On a fryer equipped with a Digital control

press the  key on the front panel. The Digital Controller will now come on and take control of heating the oil.

7. Observe the Check Fryer Indicator Light (#5, page 6) for 1 minute to verify that burner ignition has taken place. Under normal conditions the Check Fryer Indicator Light should light briefly, then go out.

Notice - If the Check Fryer Indicator Light goes out and comes back on or stays on, turn the fryer off at the Digital Control (Control Circuit Breaker (#4, page 6) for Computer Controls) Wait at least 5 minutes before repeating steps d & e to allow for accumulated gas to dissipate from the system. If the Check Fryer Indicator Light fails to go out after 5 tries consult the troubleshooting guide in the back of this manual.

8. When the Digital control shows  or the Computer control shows  the fryer is ready for use. (usually about 20 minutes with Liquid shortening and 1 hour with Solid Shortening.)

Notice - On machines built for Liquid shortening the controller will heat the shortening in a melt cycle for a minimum of 10 minutes. During this time the Digital control will show  and the Computer will show  or . When the melt cycle is complete the oil circulation pump will automatically start to circulate the oil and the fryer will continue to heat in a non melt cycle mode.

9. Check the Vacuum Gauge (#16, page 6) on a regular basis and replace the Filter Bags when indicated.

Adding Shortening:

When adding Liquid shortening to a fry tank to "Top Off" the oil level the new oil may be poured directly into the fry tank.

WARNING

Shortening, when it is at cooking temperatures, is very HOT and DANGEROUS! Use extreme caution when handling! Use the proper protective gear such as insulated gloves, aprons, face shield and sleeves when handling hot shortening.

Solid Shortening:

Notice - If you have a machine that is designed to be used with Liquid shortening and you wish to use Solid shortening you will have to purchase and install a Solid Shortening Kit. Call your Authorized Dealer for more information.

CAUTION

If Solid shortening is used, DO NOT attempt to melt the shortening in your fryer unless the controller is programmed with the melt cycle option programmed to Solid Shortening. (The Digital display will show **.CPS**). The Computer control will show **MELT S**.) Improper operation or machine damage could occur.

1. Make sure the drain valve is completely closed.
2. remove the screen covering the tube if it is still in the fry tank.
3. Cut the shortening into 1" (2.5 cm) cubes. Always pack the pieces of shortening below, beside and on top of the heat tube. DO NOT leave any large air pockets and take care not to damage any sensor probes.

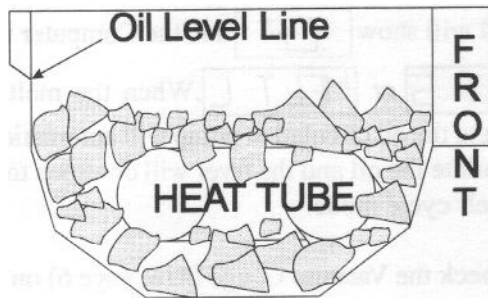

4. Start the fryer as described in the following section and allow the fryer to automatically come up to temperature. This will take approximately 1 hour and should not be bypassed. The controller will melt the shortening in short controlled bursts of heat. When the oil has reached a temperature where it is liquid the controller will automatically switch to a full run condition and the shortening will now come up to the desired temperature automatically.

Adding Shortening:

When adding Solid shortening to a fry tank to "Top Off" the oil level the new shortening must be cut into 1" (2.5 cm) cubes and added piece by piece.

Fryer Shut Down (All machines):

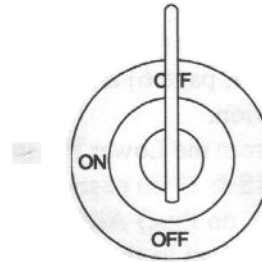

1. Always allow the fryer to operate for 5 to 10 minutes after cooking has finished to allow filter time to clear the oil.
2. Before the fryer is shut down for the night and while the oil is still hot, follow the instructions on page 12 to change the Filter Bags.
3. On a fryer equipped with a Computer controller press the ON/OFF/START Switch to the OFF position and then press the Control Circuit Breaker (#4, page 6) to the OFF position. On a fryer equipped with a Digital controller press the **Ⓢ** key on the front panel. The Digital Controller will now turn the fryer OFF. Press the Control Circuit Breaker to the OFF position.
4. If the fryer is to be left for an extended period of time, such as overnight, turn the Gas Shut Off Valve handle counter clockwise to shut the gas supply OFF.

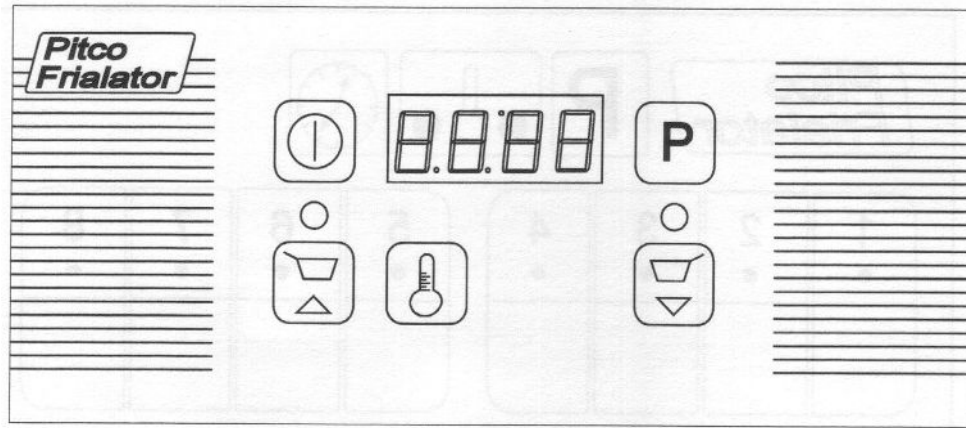





Operating the Digital Controller:

Below is listed the control functions of the Pitco Digital Controller:

Press the  key to turn the control ON. Press and hold the  key for 3 seconds to turn the control OFF.



Press the  or the  key to start the Left or Right timers



Press the  key to display the ACTUAL Temperature.

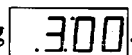

Press the  key a second time to display the SET temperature.



Programming the Digital Control:

Press the  key to enter the program mode.

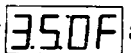



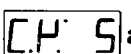



Once the program mode has been entered the display will show the LH Timer setting . An adjustment may be made by using the  or  keys.

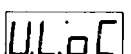

Press the  key again and the display will allow you to change the RH Timer setting by using the  or  keys.



Press  again, the display will show  and the Set Temperature may be changed by using the  or  keys.

Press  again, the display will show  and the Melt Cycle Options may be selected by using  or  keys. S may be selected to allow for a mild Melt Cycle needed for Solid Shortening. L may be selected to

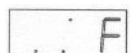
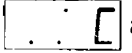
allow for a more aggressive Melt Cycle needed for Liquid cooking media. O may be selected to bypass a Melt Cycle.

Press  again, the display will show  or  and the Password option may be set by using  or . If a Password Required option is programmed the Password will be   then   and is not adjustable.

Press  again, the display will show  or  and the Fahrenheit or Celcius option may be chosen by using  or  keys.

Press  again and the display will return to the LH Timer setting. To exit the Programming mode at any time, press and hold  for three seconds.

The following messages may also be seen in the display:

 indicates the fryer is ready for cooking.

 indicates the controller is in the heating mode.

 indicates the controller is in a Melt cycle.

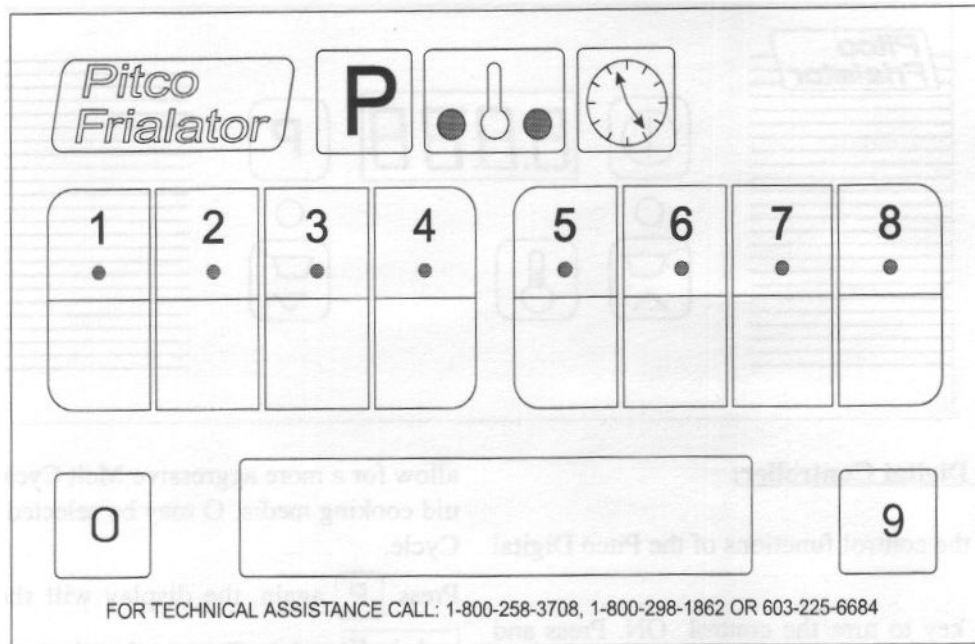

 indicates the controller is outputting a heat signal.



Operating the Computer Control:





Checking the Temperature functions and Cooking times -

To check the ACTUAL temperature press the  once.

To check the SET temperature press the  key two times. After 5 seconds the display will return to normal. To check the COOK, SHAKE and HOLD times press the  followed by the product key you wish to check.



The times will be displayed in sequence followed by a short pause, finally returning to the normal cook mode. When the computer is calling for heat the two lights in the lower corners of the  key will illuminate.

Programming Cook Time, Shake Time and Hold Times:

To set the COOK time press the  key then the  key. Enter the desired product key and change the desired time by using the numbered keys. Press the  key to set the corresponding SHAKE time using the numbered keys. Press the  key to set the corresponding HOLD time using the numbered keys. Pressing the  key two times at any point during this procedure will return you to the normal cook mode.



Programming Cooking Temperature.



This setting determines the thermostat setting for the computer. Unlike conventional thermostats, once the computer is set it will never need calibration. Set the desired temperature by performing the following procedure.



Press the  key followed by the  key. The new COOK temperature may now be set using the numbered keys. Pressing the  key two times at any point during this procedure will return you to the normal cook mode.

Level 2 Programming:

There are several features that merit mention at this point. Their programming functions are explained along with their descriptions.

To enter the level 2 programming mode press the  key followed by the  key. If a password has been set you will be asked to enter it, if you do not remember what the password is use "6684". This will allow you to program these basic functions and reset the password.

To choose between "°F" or "°C" press the  key and use the  key to toggle between the options.

To set the PASSWORD option press the  key and use the  key to toggle between the two options.

PASS REQ & **NO PASS**. To set a new password press the **P** key and enter a four digit password, the display will show **SET PASS** then **PASS1234**. Press the **P** key again and the display will return to the normal cook mode. To continue setting level options in the level 2 programming you must re enter to level 2 programming mode in the same manner as before.

To set the beeper volume press the **3** key and use the **0** key to toggle between the options.

To set the Language option press the **4** key and use the **0** key to toggle between the options. At the time of printing the only language option available is SPANISH **ESPAÑOL**. When a language option has been set the display will show in that language.

Pressing the **P** key two times at any point during this procedure will return you to the normal cook mode.

To set the melt cycle option press the **5** key and use the **0** key to toggle between the three options available. Solid shortening melt cycle **SOLID**, Liquid shortening melt cycle **LIQUID** or no melt cycle **LIQUID**. It is highly recommended that a melt cycle is used to ensure longevity of oil and fryer.

To view the recovery test data press the **6** key followed by any numbered key to view the stored data. Each time the fryer heats through the temperature range of 250°F - 300°F it records (in seconds) the time it took and stores it as recovery data. This data can be recorded when the fryer is new and viewed again at a later date to see whether the fryer is performing correctly.

To set the control mode press the **7** key and use the **0** key to toggle between the options. The computer may be set in a **CONTROL** mode for total computer control or in **TIMER** mode where the Auxiliary Thermostat will control the temperature of the oil and the computer will act as a timer.

To exit the level 2 programming mode at any time press the **P** key two times. This will return you to the normal cook mode.

Main Filter Bag Changing Procedure:

Although the Turbofry 2000 is a continuous filtering machine the Main Filter Bags will need to be changed on a daily basis (Depending on usage.) The vacuum gauge is graduated so that it will show the condition of the Filter Bags. When the Filter Bags are new the needle will read in the GREEN zone, as the Filter Bags fill up with debris the needle will rise. The YELLOW zone is an indication that the Filter Bags are filling and that it is time to change the Filter Bags is getting close. If the Turbofry 2000 is in use (the middle of Supper for example) when the needle moves to the top of the YELLOW zone it is permissible to wait until the soonest available time until changing the Filter Bags. If the needle rises into the BLUE zone it is time to change or clean the Filter Bags.

NOTICE - It is important that the operators become familiar with the fryer and the times at which it will need filtering. This will alleviate the need to shut the fryer down and filter during a critical cooking period.

Follow the steps outlined below to complete the filtering process:

(The numbers referenced below refer to the Component Recognition drawing on page #6.)

1. Using the supplied Filter Bag Removal Tool, remove the Filter Bag Guard and place in an area where the oil can drain.
2. With the machine running brush the area around the Filters to stir up any debris to be collected by the Filter Bags.
3. Turn the machine off by pressing the  key on the Digital Control (#15). (Press the ON/OFF/TEST Switch for Computer controlled machines.)
4. Open the Green Drain Valve Handle (#9) by turning clockwise until it is in the vertical position. The oil will now drain into the lower pan (#14).
5. Turn the pump on by pressing the Pump Override Switch (#3). The Filter Pump will start and the oil will be pumped from the Filter Bags.
6. After approximately 1-3 minutes or when the oil has stopped coming out of the Oil Circulation Tube the Oil will have been pumped from the Filter Bags, turn the pump off with the Pump Override Switch (#3). The pump will stop running.
7. It is recommended that the Sump Screen Assembly (#12) be checked daily. Pull the Cover (#13) out and away from the Sump Screen Assembly (#12). Allow the oil to drain fully.

8. Turn the Sump Screen Assembly (#12) counter clockwise until it becomes free from its housing.
9. Pull the Sump Screen Assembly (#12) out slightly and allow any excess oil to drain into the lower pan. Inspect the screen for debris. If any debris is found shake the Sump Screen Assembly until it is clean.

WARNING

Since Water will instantly boil when it is introduced into cooking temperature oil it is very important that ALL parts be completely DRY before reassembly.

10. To install the Sump Screen Assembly feed the assembly into the hole and turn clockwise until the threads seat. Close the Cover.
 11. Using the supplied Filter Bag Removal Tool remove a Filter Bag Retainer along with its Filter Bag. The Filter Bag will be 1/3 to 1/2 full of debris. (Follow the recommendations outlined at the beginning of the section regarding the reuse of the Filter Bags.) Lift the Filter Bag from the Retainer and discard. The Filter Bag Retainer can now be washed with hot water. Repeat this process for the second Filter Bag.
 12. Install the new Filter Bag by hanging it on the Filter Bag Retainer. Feed the bottom of the Filter Bag into the housing using the Clean Out Rod to make sure the bottom of the Filter Bag rests in the bottom of the housing.
- Notice** - It is important that the Filter Bags are located in the bottom of the housing and are NOT bunched up. Also that the top of the Filter Bag where it hangs on the Retainer should, once installed, protrude slightly over the top of the Filter Bag Retainer.
13. Repeat step #12 for the second Filter Bag.
 14. Close the Green Drain Valve handle (#9).
 15. Replace the Filter Bag Cover over the Filter Bag Housing.
 16. Pull the Pump Inlet Selector Knob (#17) OUTWARD so that the filter pump will suction from the Lower Pan (#14).
 17. Press the Pump Override Switch (#3), the pump will start and the oil will return to the fry tank. When the Filter Pan (#14) is empty turn the Pump Override switch OFF.

Notice - This would be the ideal opportunity to use the Flush Hose. Follow the instructions outlined in the next section for the use of the Flush Hose.

18. Press the Flush Hose Selector Knob INWARD.

19. Disconnect the Filter Pick Up Assembly (#10) from the Pump Suction Connection (#11) by grasping the Filter Pick Up Assembly (#10) and pulling to the left as shown.

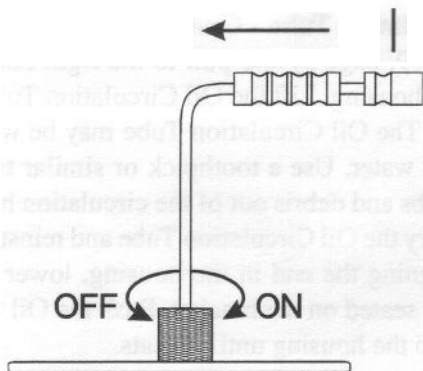

20. Pull the Filter Pan (#14) out and remove the Filter Pick Up Assembly (#10) from the pan. Unscrew the large nut at the end of the Filter Pick Up Assembly (#10) from the Pick Up Screen. Each piece may now be washed with soap and water or in the dish washer.
21. When the parts are clean and dry they can be reassembled by screwing the Filter Pick Up Assembly (#10) onto the Pick Up Screen in a clockwise direction. Place the assembly in the bottom of the Filter Pan (#14) and push the Filter Pan (#14) under the fryer. Carefully place the Filter Pick Up Assembly (#10) end into the Pump Suction Connection and press together.
22. Turn the fryer on by pressing the  key on the Digital Control (#15).

Your fryer is now ready to use.

Flush Hose Operation:

The Turbofry 2000 has a Flush Hose feature that will allow the user to wash down the inside of the fry tank. The Flush Hose can also be used for pumping the oil into a waste oil container when it is no longer usable.

CAUTION

The Flush Hose can discharge HOT oil. Use extreme caution when handling! Never start the pump without first ensuring that the hose is pointed in a safe direction.

1. Connect the Flush Hose to the Flush Hose Connector (#6) by pulling the black ring back on the quick disconnect. Push the hose end onto the connection

and release the black ring.

2. Drain the oil from the fry tank into the Lower Pan (#14) by turning the Drain Valve Handle (#9) clockwise into the open position.
3. Pull the Pump Outlet Selector (#7) into the Flush Hose position.
4. Pull the Pump Inlet Selector Knob (#17) into the Lower Pan position.
5. Point the nozzle into the fry tank.
6. Turn the pump ON by pressing the Pump Override Switch (#3) to the ON position. Use the Flush Hose for the desired purpose. Turn the pump OFF by pressing the Pump Override Switch (#3) to the OFF position.
7. When finished direct the end of the Flush Hose Nozzle into the Lower Pan to prevent spilling.

CAUTION

The fitting where the flush hose attaches to the fryer will be very hot after use. Use insulated rubber gloves and extreme caution when handling.

Pull the black ring back on the quick disconnect and release the Flush Hose connection. Allow all of the oil in the Flush Hose to drain into the Lower Pan. The Flush Hose should now be removed to its storage location.

8. Press the Pump Outlet Selector (#7) until it stops.
9. Turn the Drain Valve Handle (#9) counter clockwise to close the drain valve. Refill the fry tank by pressing the Pump Override Switch (#3) to the ON position. When the Lower Pan (#14) is empty turn the Pump Override switch OFF.
10. Press the Flush Hose Selector Knob INWARD.

Your fryer is now ready to use.

Chapter 4. PREVENTATIVE MAINTENANCE.

In order to keep your new Pitco Frialator Turbofry 2000 operating and looking in top condition it is necessary to perform a few simple tasks on a daily, weekly, monthly and quarterly basis. Follow the chart below to find the frequency at which these Preventative Maintenance Items should be performed:

Cleaning	Daily and Weekly
Vacuum Gauge Inspection	Daily
Boil Out	Monthly or when needed
Air Filter Inspection	Every 3 months
Inspect O-Rings on-	
Filter Bag Housing	Every 3 months
Oil Circulation Tube	Every 3 months
Sump Screen	Every 3 months
Service Tech Inspection	Yearly

Follow the directions outlined below for the instructions on how to perform the given task:

Daily Cleaning:

It is recommended that, in addition to filtering, the external components of the fryer be cleaned in the following manner.

Turn the fryer OFF by pressing the  key on the Digital Control panel. Using a soft clean cloth to wipe the exterior surfaces until they are free of oil. A small amount of non abrasive cleaner may be used on stubborn stains.

Weekly Cleaning:

At least once a week the following preventative maintenance procedures should be performed:

- Clean Filter Bag Housing,
- Clean Pump Suction Screen,
- Clean Oil Circulation Tube,
- Clean Fry Tank using the Boil Out procedure,

Follow the instructions below for instructions on each of these items:

Filter Bag Housing - After the oil has been drained from the Filter Bag Housing (Step #12 and 14 in the Filtering Procedure.) Use the supplied Filter Bag Removal Tool to lift the complete Filter Bag Housing out of the machine. Wash the Filter Bag Housing with soap and water to remove all debris. Dry thoroughly and install in the machine. Make sure the Housing is seated correctly before installing the Filter Bags.

Pump Suction Screen - Follow the instructions outlined in the Main Filter Bag Changing Procedure, step #s 8 through 11. Use an abrasive, NON metallic, scouring pad on persistent stains.

Oil Circulation Tube - Grasp the Oil Circulation Tube Handle (#9, page 5) and pull to the right until it is free from the housing. Lift the Oil Circulation Tube from the fry tank. The Oil Circulation Tube may be washed with soap and water. Use a toothpick or similar tool to push the crumbs and debris out of the circulation holes. Thoroughly dry the Oil Circulation Tube and reinstall by carefully aligning the end in the housing, lower the handle until it is seated on the bracket. Push the Oil Circulation Tube into the housing until it seats.

Vacuum Gauge Inspection:

Each time that the pump is switched off or the machine shuts the pump off during a Filter Bags Change, check the Vacuum Gauge (#16, page 6) to make sure the needle points to the zero mark. The Vacuum Gauge will only point to zero when the pump is NOT rubbing. If it does not point to the zero or very close call an Authorized Service Agency to have the Vacuum Gauge checked.



Boil Out Procedure:

Periodically it will be necessary to perform what is known as a **Boil Out**. This removes baked on frying oil from the inner surfaces of the fry tank. This is best accomplished when the oil is ready to be replaced.

Due to the unique design of the TURBOFRY 2000, the **Boil Out** procedure is more involved than that of a regular fryer. It is an easy job if the steps in the procedure outlined below are followed. Always use Pitco Fryer Cleaner to boil out the TURBOFRY 2000. Other cleaners not approved by Pitco may be harmful to materials used in the construction of the TURBOFRY 2000. Any damage done by the use of other cleaners will not be covered by the Pitco warranty. The Procedure has 3 main parts - Cleaning, Neutralization and Rinsing.

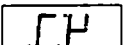
Cleaning:

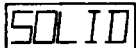

Check that the controller is programmed to heat with a melt cycle, the Digital display will show .



(The Computer display will show  or .)

Check the current Set Temperature setting of the controller. Reprogram the controller to a temperature set-

ting of 200° F. (Follow the instructions in the appropriate section of this manual.)

Notice - Even though we call this a **Boil Out**, there is no need to boil the water. 200°F is hot enough for the cleaner to work and will prevent the mess and hazards of a boil over.

3. Shut the fryer OFF by pressing the  key on the Digital controller. (Press the OFF/ON/START switch to the OFF position on Computer controlled machines.)
4. Drain all of the oil from fry tank and filter bags into the lower pan by opening the Green Drain Valve (#9, page 6). Remove any pieces of food that may have accumulated on the bottom of the fry tank or in the Sump and Sump Screen. Remove the Sump Screen assembly (#12, page 6) and clear any particles from it. Return the Sump Screen assembly to its housing and make sure it is seated. Remove the soiled Filter Bags and install clean ones.
5. Fill the fry tank with water to the OIL LEVEL mark on the inside of the fry tank.
6. Turn the fryer ON by pressing the  key on the Digital control. (Press the OFF/ON/START switch to the ON position on Computer controlled machines.)

Notice - Allow the fryer to heat for 10-15 minutes until the Digital display changes to  (Computers will show ) before adding Pitco cleaner. Adding cleaner while the fryer is heating up could cause a boil over. At this time the pump should have started to circulate the water.

7. Add 8 Ounces by weight of Pitco Fryer Cleaner to the water. (4 sample packets, supplied with your new fryer.)
8. Allow the Pitco Fryer Cleaner and hot water to soak with the pump running for 45 minutes, the fryer will hold the cleaning compound at 200°F.
9. While the cleaner is soaking, use the white fryer cleaning brush to scrub all the inner surfaces of the fry tank, splashback, basket hanger, and the fry baskets.
10. After 45 minutes, turn the fryer OFF by pressing and holding the  key on the Digital control. (Press the OFF/ON/START switch to the OFF position on Computer controlled machines.)
11. Rotate the Drain Outlet Pipe (#8, page 6) to point outward. Place a heat resistant 3-5 gallon container

under the Drain Outlet Pipe.

12. Drain the fry tank by slowly opening the Green Drain Valve Handle (#9, page 6). The used **Boil Out** water and Pitco cleaner is safe to pour down a sink drain.

Notice - The water from the fryer could be hot enough to damage plastic drain systems. Run cold tap water as you pour the hot cleaner down the drain to protect plastic drain systems.

13. Turn the pump on by pressing the Pump Override Switch (#3, page 6) to drain the filters. Allow the pump to run until the Filter Bags are empty of water. Remove and dispose of the soiled Filter Bags.
14. Use a Green Scouring Pad or similar Non Metallic abrasive cleaning pad to remove any carbonized deposits from the inner surfaces of the fry tank. Rinse all surfaces after scrubbing.
15. Remove the Oil Circulation Tube Assembly (#5, page 5) and rinse it. Rinsing should be done from the outside of the Circulation holes to the inside of the tube to prevent plugging the holes, a toothpick or similar tool may be used.
16. If after completing the previous steps, the fry tank is not cleaned to your satisfaction, repeat steps 5 through 15. If the fry tank is clean go to step 17. If the fryer cleaner did not clean the fryer adequately, then **Boil Outs** should be performed more frequently to prevent heavy build up.
17. Use clean water to rinse the fryer cleaner out of the fry tank. Use the brush or a clean towel to rinse all surfaces that were contacted by the fryer cleaner. Repeat the rinsing until all surfaces are free of cleaner residue.

Notice - If you are using the recommended Pitco Fryer Cleaner (Pitco part Number P6071397) which is a "Non Caustic" cleaner or another brand Non Caustic cleaner skip the Neutralization steps (18 through 23).

Neutralization:

18. Fill the fryer with fresh water to the OIL LEVEL line on the rear of the fry tank. Add 1/2 gallon of white vinegar to the water.
19. Connect the flush hose to the flush hose fitting. Start the pump by pressing the Pump Override Switch (#3, page 6). Let the pump run for 1-2 minutes. Stop the pump. Pull the Pump Outlet Selector (#7, page 6) to the Flush Hose position, place the end of the hose nozzle into the fry tank, and start pump by pressing the Pump Override Switch. This will neutralize the cleaner in the flush hose lines. Use the brush or a

clean towel to wipe the neutralizer solution over all the parts that were cleaned with the fryer cleaner. Once the entire fryer has been neutralized, drain the fry tank and filter sump by following steps 12 and 13.

20. Close the Green Drain Valve Handle and fill the fryer with fresh water to the OIL LEVEL line on the rear of the fry tank. Rinse the fry tank, splashback, basket hanger, and the fry baskets. Operate the pump as in step 19.
21. Drain the fry tank and filter sump of all water, This includes removing the Sump Screen Assembly (#12, page 6) and allowing all water to drain from the sump housing. Replace the Sump Screen Assembly in the sump housing and return the Sump Drain Handle (#13, page 6) to its normal operating position.
22. Wipe the fry tank, splashback, basket hanger, and the fry baskets with clean dry towels to remove all water. Install the Oil Circulation Tube Assembly (#5, page 5). This completes the neutralization part of the **Boil Out** procedure.
23. Install new filters in the filter sump. Pull the Pump Inlet Selector Knob (#17, page 6) to the "Lower Pan" position.
24. Turn the Drain Valve Handle (#9, page 6) counter clockwise to the "Closed" position. Use the Pump Override Switch to start the pump and pump all of the oil from the lower pan to the fry tank to a level ½" below the OIL LEVEL mark at the rear of the fry tank.

CAUTION:

The next step will be very noisy as the fryer evaporates the remaining water in the fry tank and pump lines. Allow the pump to run the entire time it takes to evaporate the residual water. If the pump is not left running, there is a chance that steam could build up in the unit and discharge hot oil.

25. Turn the fryer on using the **Ⓛ** key. Enter the program mode to reset the temperature to the original setting as noted in step 3. The fryer will now heat the oil and evaporate any remaining moisture.
26. Allow the fryer to heat the oil until all the moisture from the boil out is evaporated. The amount of time required to do this will vary with the degree of dryness that was achieved during the wipe down after rinsing, generally it takes 15 -20 minutes to dry the oil.

Notice -The best way to tell if the system has dried out by the appearance of the oil. When the oil is dry, there will be no small bubbles visible in the oil. At this point the fryer can be shut down.

27. Shut the fryer OFF by pressing the **Ⓛ** key on the Digital controller. (Press the OFF/ON/START switch to the OFF position on Computer controlled machines.) Drain fry tank and filter sump and dispose of the used oil.
28. Fill the fryer with new cooking oil. The **Boil Out** is now complete.

Air Filter Inspection:

Remove the 8 screws that hold the Air Filter cover in place, grasp the handle and pull outward until the entire Air Filter extends out of its housing. Inspect the air Filter for dirt and debris. If the Air Filter has a light coating of dust, it may be removed and cleaned by gently tapping it against a hard surface so that the particles fall out of the filter material. Check for anything that may obstruct air flow. If, for any reason, the Air Filter requires changing pull it out of the housing by lifting upwards and install a new Air Filter.

Notice - The Air Filter has a directional arrow on it. Make sure the arrow is pointing in the direction of the air flow.

Push the Air Filter Housing in until it stops and the cover seats, replace ALL of the screws and tighten them. Take care not to overtighten.

Inspect O-Rings:

Choose a time when the machine has been cleaned and allowed to cool to perform any O-Ring inspection. Take great care NOT to stretch the O-Ring.

Filter Bag Housing - Lift the Filter Bag Housing out as described in the Main Filter Bag Changing Procedure on page 12. Using a small Dental Pick or Flat Tipped Screwdriver carefully lift the O-Ring out of its groove. Inspect the O-Ring for any Dry, Cracked or Flat surfaces, if the O-Ring has any of these areas it should be replaced.

To install the O-Ring, first clean the groove to make sure it is clear of any debris or pieces of old O-Ring. Cover the new O-Ring in a little cooking oil which will make the installation a little easier. Place the O-Ring in its groove making sure it is has not twisted during the installation. If it did twist gently untwist it and replace it in

the groove. Make sure the O-Ring has seated in the bottom of the groove and reinstall the Filter Bag Housing.

Oil Circulation Tube - There is an O-Ring inside the housing where the Oil Circulation Tube seats. Use a Curved Dental Pick to extract the O-Ring. Inspect it for Dry, Cracked or Flat surfaces. To reinstall the O-Ring Place the O-Ring in its groove making sure it is has not twisted during the installation. If it did twist gently untwist it and replace it in the groove. Make sure the O-Ring has seated in the bottom of the groove and reinstall the Oil Circulation Tube.

Sump Screen - Unscrew the Sump Screen as described in the Main Filter Bag Changing Procedure on page 12. Inspect it for Dry, Cracked or Flat surfaces. To reinstall the O-Ring place the O-Ring in its groove making sure it is has not twisted during the installation. If it did twist gently untwist it and replace it in the groove. Make sure the O-Ring has seated in the bottom of the groove and reinstall the Sump Screen Assembly.

Service Technicians Inspection:

On a yearly basis an Authorized Parts and Service Technician should perform the following Preventative Maintenance checks:

- 1.* Remove and clean or replace the Air Filter.
2. Perform recovery test.
3. Check input gas pressure.
4. Remove burner and inspect for sooting or other damage.
5. Check calibration of controls.
6. Remove and replace the Pump Suction Connection O-Ring, Oil Circulation Tube O-Ring and the Sump Screen O-Ring.
- 7.* Inspect the Filter Housing O-Ring, replace when needed.
8. On machines equipped with Heaters, check to make sure they are heating correctly.
- 9.* Inspect the Vacuum Gauge to make sure it is returning to zero.

* These are steps which the end user will normally perform, however, during the Technician' scheduled visit they are performed as part of the overall Preventative Maintenance (PM) service.

It is estimated that this should take approximately 2 - 2.5 hours.

Storing the TURBOFRY 2000:

If you need to store the TURBOFRY 2000 for an extended period of time. Please follow the guidelines below:

Never leave oil (or solid shortening, if equipped for solid shortening) in the fryer for longer than 7 days.

Boil out the fryer and operate the pump with fresh, clean cooking oil to prevent corrosion from occurring inside the pump.

Wipe up any oil spills around the front of the electrical box.

Wash the Lower Pan and Lower Pan Pick Up Assembly thoroughly.

Was the outside of the fryer with a heavy duty detergent to remove any jelled cooking oil.

Shut off all gas and electric service to the fryer.

Returning the TURBOFRY 2000 to service after storage:

Reconnect the gas and electric service, and have them tested by qualified Personnel.

Have the TURBOFRY 2000 checked out by an Authorized Service and Parts (ASAP) technician.

If the storage was for longer than 7 days, the pump shaft should be checked to see that it turns freely. If the pump shaft does not turn freely, it must be freed up before attempting to operate the TURBOFRY 2000.

Chapter 5. PARTS:

Blower, Variable Speed 240V 50/60HZ	PP11091	Spider Coupling	PP11089
Burner, Nat Gas	B8021001	Switch, High Limit- Snap Disc - 425 Deg ...	PP11064
Burner, LP Gas	B8021002	Switch, Motor Starter	PP11195
Burner Gasket	A8019401	Switch, Pressure Sensing	PP10925
Capacitor, Motor Starting	PP11196	Tank Assembly	B3319101
Caster, Swivel	PP11113	Tape, Heat 240VAC	PP10298
Caster, Locking	PP11114	Tube Assembly, Pickup	B6646401
Circuit Breaker, 15 Amp	PP11074	Tube Rack	B4511301
Circulation Tube Assembly	B6651001	Valve, Gas 1" -24VAC NAT/LP	PP11092
Circulation Tube Assembly	B6651001	Valve, Gas Poppet	PP11094
Clamp, Filter Bag	B6646701	Valve, Manual Shut Off	PP11072
Contactora, Motor Starting - 24VAC	PP11102	Vibration Pad	A7010701
Controller Digital T-Stat	PP11082	Vibration Washer	A7010801
Controller, Fan - 2 Speed	PP11099	Wire, Ignition	PP11200
Door Assembly - RH	B2302501		
Door Assembly - LH	B2302502		
Door Assembly - RH	B2302501		
Door Assembly - LH	B2302502		
Drain Fitting Screen	B3319601		
Filter, Air	PP1 1072		
Filter Bags (64 Count)	A7011101		
Filter Removal Tool	A4018002		
Gauge, Pressure	PP11223		
Gauge, Vacuum	PP11073		
Handle Assy, Drain Valve	B4002201		
Hanger, Basket	A1105002		
Holder, Filter Bag	B6646901		
Hose, Fluoropolymer	B6647501		
Insulator, O-Ring Fitting	A7005601		
Knob, Plastic 1"	PP11218		
Main O-Ring Fitting	B6646801		
Module, Ignition Control - 24VAC	PP11096		
Motor, Filter Pump - 230V 1 Ph	B5304701		
O-Ring, 0.5" ID	PP10111		
O-Ring, 1" ID	PP11104		
O-Ring, 1.25" ID	PP11188		
O-Ring, 13" ID	PP11105		
Orifice, Burner	A8002721		
Orifice, Main Burner	P6071336		
Pan Assembly	B6645801		
Probe, Ignition/Flame Sensor	PP11100		
Pump, Gear Oil w/relief valve	B6646301		
Pump Selector Rod	A4018602		
Pump Strainer	B6646601		
Regulator, Gas Pressure	PP11093		
Relay DPDT-24VDC	PP11068		
Relay, Over Load	PP11103		
Screen Assembly, Filter Pickup	B6646501		
Spider Bushing	PP11080		

Chapter 6: TROUBLESHOOTING.

Symptom	Cause	Repair
Vacuum Gauge in black area,	Filter Bags are clogged or are old.	Install new filters (Page 12). Filters can be reused for up to 2 days, after 2 days, the fibers are saturated, and material is hardened. dispose of filters, replace.
High vacuum gauge reading.	Cold oil. Clogged Sump Screen. Incorrect Filter Bag installation, debris has clogged the Filter Bag Housing. Dirty or clogged Filter Bags. Filter Bag has a hole in it. Mechanical Problems.	Allow the oil to rise to operating temp and recheck the VACUUM GAUGE. Caused by a failure to clear the area around the filter bags before changing. Clean the Filter Bag Housing (Page 13). Remove the Filter Bags and Filter Bag Housing, clean and reinstall (Page 12 & 13). New Filter Bags should be used to prevent the introduction of debris to the system. Install a new Filter Bag. The Vacuum Gauge may be defective. Call an Authorized Service and Parts Distributor.
Low oil flow in cook zone, gauge needle in Yellow.	Filter Bags are becoming full.	Install new Filter Bags (Page 12).
Bubbles coming from the right rear corner of the fry tank	Product has a high moisture content. Filter Bags are filling. Oil level is low. Pump Inlet Selector set to PAN.	This is a normal reaction to high moisture content. Check the Vacuum Gauge for Filter Bag status. Add cooking oil as needed. Push the Pump Inlet Selector Knob in to select the MAIN FILTERS position.
Low oil flow in cook zone, filter bags are clean	Large amounts of high moisture content foods are being cooked.	This is normal and will disipate shortly.
High pressure reading on PRESSURE GAUGE	OIL CIRCULATION TUBE is becoming blocked. FLUSH HOSE valve not in fry pot position.	Remove the OIL CIRCULATION TUBE as described on page 13 and clean the orifices with a toothpick or similar item. Place the PUMP OUTLET SELECTOR in the FRY TANK position.
Cooking controller displays "drm" "trn" "off" decribed on pages 7 & 8.	DRAIN HANDLE is in open position or has not been closed fully.	Close DRAIN HANDLE and refill the fry tank as described on page 12. Check the DRAIN HANDLE by pushing closed. The machine will have to be shut down and started up ageain as
No oil is coming out of the flush hose	PUMP OUTLET SELECTOR is not set on FLUSH HOSE. No oil in LOWER PAN. LOWER PAN PICK UP ASSEMBLY not connected properly.	Check the position of the PUMP OUTLET SELECTOR and change as needed. Follow the directions outlined on page 12. Remove the LOWER PAN PICK UP ASSEMBLY and install it into the LOWER PAN PICK UP CONNECTION until it seats properly.

NOTES:

- CONNECTOR J8 IS SUPPLIED WITH M2, CONNECTOR J5 IS SUPPLIED WITH A1 AND CONNECTOR J12 IS SUPPLIED WITH A2.
- ALL WIRES TO BE 18 GAUGE UNLESS OTHERWISE SPECIFIED.

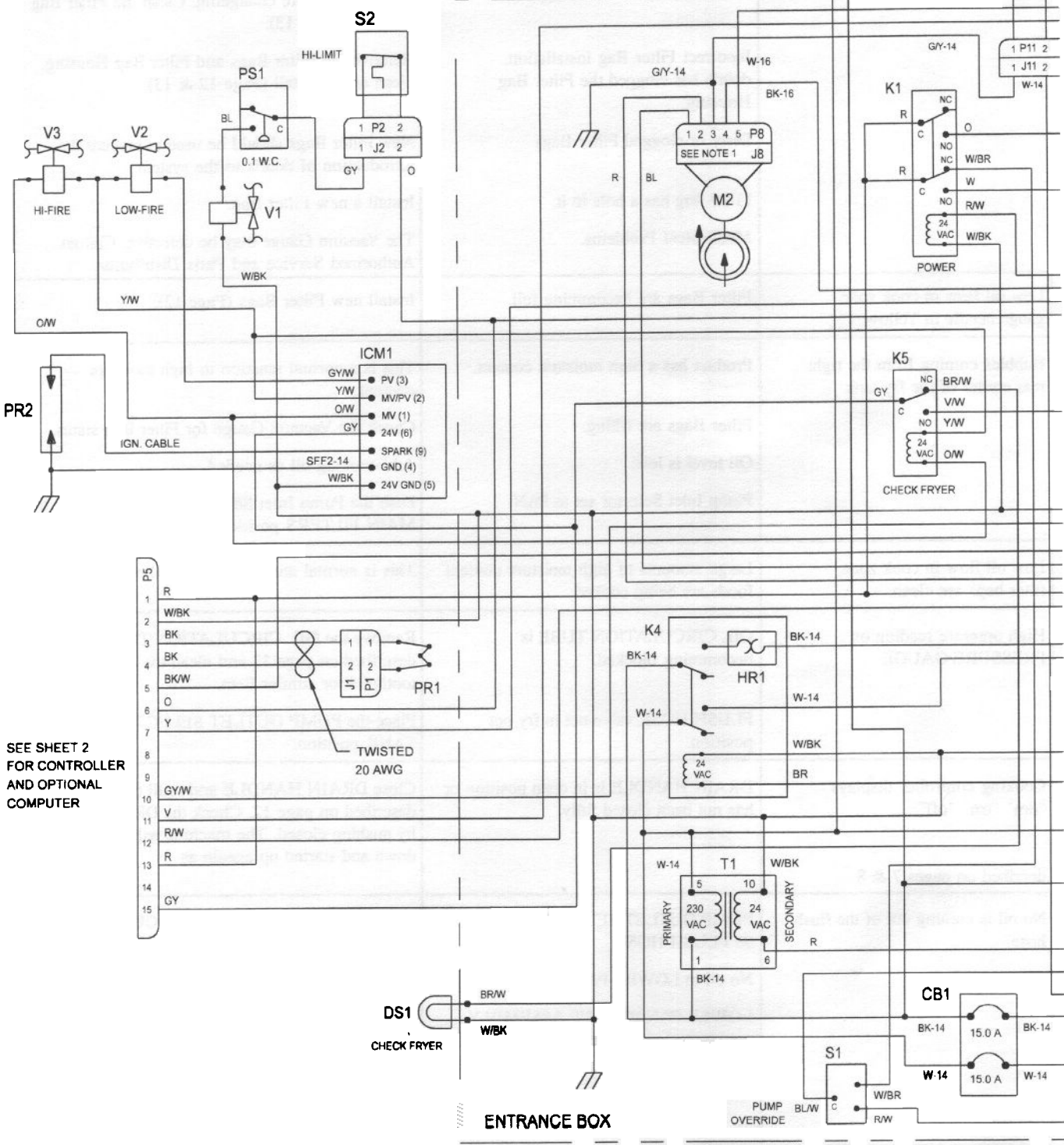
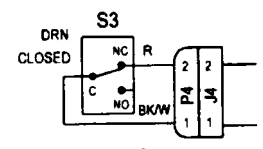
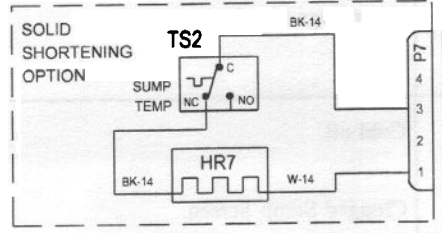

SEE SHEET 2 FOR CONTROLLER AND OPTIONAL COMPUTER

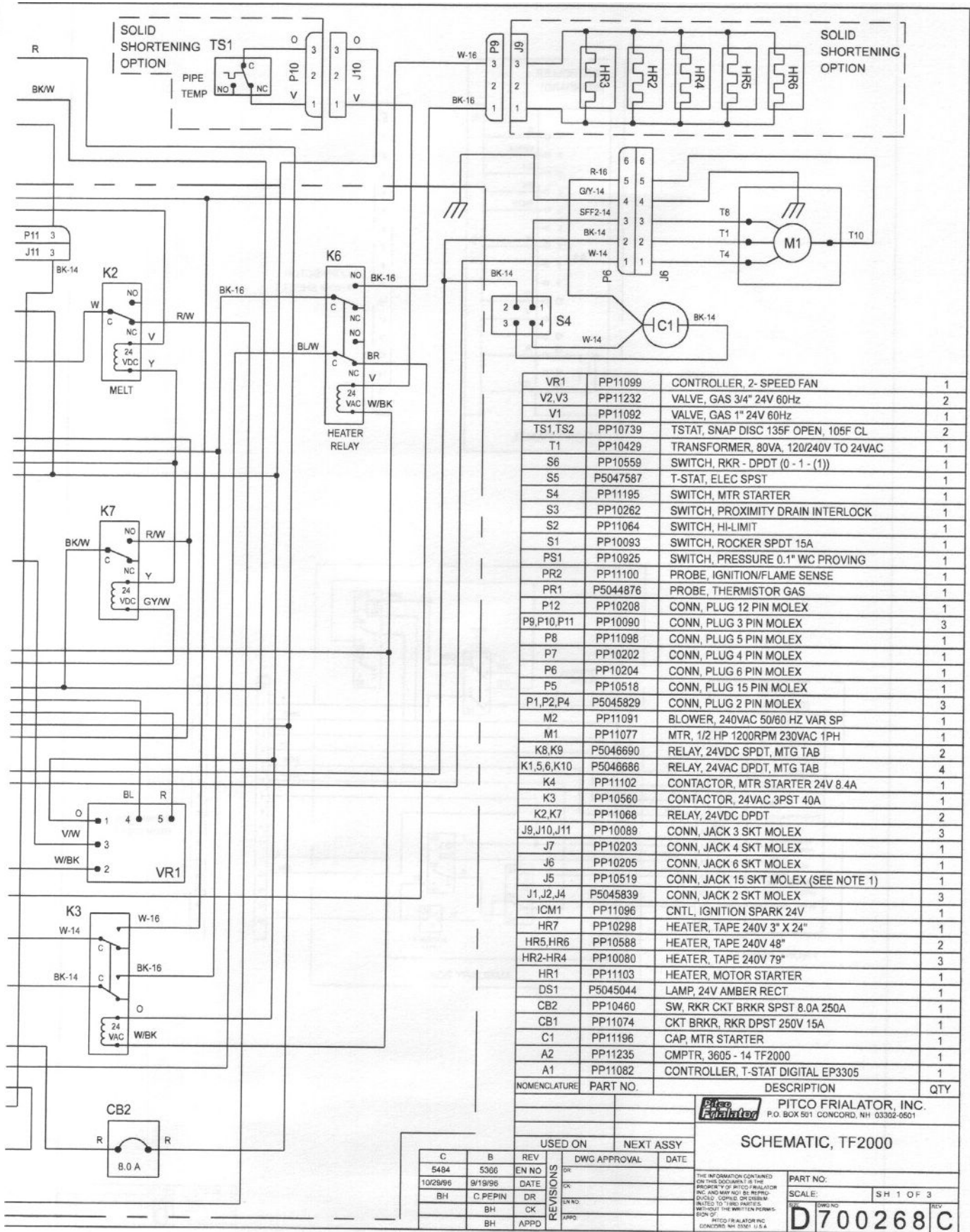

VR1	PP11099	CONTROLLER, 2-SPEED FAN	1
V2,V3	PP11232	VALVE, GAS 3/4" 24V 60Hz	2
V1	PP11092	VALVE, GAS 1" 24V 60Hz	1
TS1,TS2	PP10739	TSTAT, SNAP DISC 135F OPEN, 105F CL	2
T1	PP10429	TRANSFORMER, 80VA, 120/240V TO 24VAC	1
S6	PP10559	SWITCH, RKR - DPDT (0 - 1 - (1))	1
S5	P5047587	T-STAT, ELEC SPST	1
S4	PP11195	SWITCH, MTR STARTER	1
S3	PP10262	SWITCH, PROXIMITY DRAIN INTERLOCK	1
S2	PP11064	SWITCH, HI-LIMIT	1
S1	PP10093	SWITCH, ROCKER SPDT 15A	1
PS1	PP10925	SWITCH, PRESSURE 0.1" WC PROVING	1
PR2	PP11100	PROBE, IGNITION/FLAME SENSE	1
PR1	P5044876	PROBE, THERMISTOR GAS	1
P12	PP10208	CONN, PLUG 12 PIN MOLEX	1
P9,P10,P11	PP10090	CONN, PLUG 3 PIN MOLEX	3
P8	PP11098	CONN, PLUG 5 PIN MOLEX	1
P7	PP10202	CONN, PLUG 4 PIN MOLEX	1
P6	PP10204	CONN, PLUG 6 PIN MOLEX	1
P5	PP10518	CONN, PLUG 15 PIN MOLEX	1
P1,P2,P4	P5045829	CONN, PLUG 2 PIN MOLEX	3
M2	PP11091	BLOWER, 240VAC 50/60 HZ VAR SP	1
M1	PP11077	MTR, 1/2 HP 1200RPM 230VAC 1PH	1
K8,K9	P5046690	RELAY, 24VDC SPDT, MTG TAB	2
K1,5,6,K10	P5046686	RELAY, 24VAC DPDT, MTG TAB	4
K4	PP11102	CONTACTOR, MTR STARTER 24V 8.4A	1
K3	PP10560	CONTACTOR, 24VAC 3PST 40A	1
K2,K7	PP11068	RELAY, 24VDC DPDT	2
J9,J10,J11	PP10089	CONN, JACK 3 SKT MOLEX	3
J7	PP10203	CONN, JACK 4 SKT MOLEX	1
J6	PP10205	CONN, JACK 6 SKT MOLEX	1
J5	PP10519	CONN, JACK 15 SKT MOLEX (SEE NOTE 1)	1
J1,J2,J4	P5045839	CONN, JACK 2 SKT MOLEX	3
ICM1	PP11096	CNTL, IGNITION SPARK 24V	1
HR7	PP10298	HEATER, TAPE 240V 3" X 24"	1
HR5,HR6	PP10588	HEATER, TAPE 240V 48"	2
HR2-HR4	PP10080	HEATER, TAPE 240V 79"	3
HR1	PP11103	HEATER, MOTOR STARTER	1
DS1	P5045044	LAMP, 24V AMBER RECT	1
CB2	PP10460	SW, RKR CKT BRKR SPST 8.0A 250A	1
CB1	PP11074	CKT BRKR, RKR DPST 250V 15A	1
C1	PP11196	CAP, MTR STARTER	1
A2	PP11235	CMPTR, 3605 - 14 TF2000	1
A1	PP11082	CONTROLLER, T-STAT DIGITAL EP3305	1
NOMENCLATURE	PART NO.	DESCRIPTION	QTY

C	B	REV	DWG APPROVAL	DATE
5484	5306	EN NO		
10/29/96	9/19/96	DATE		
BH	C.PEPIN	DR	REVISIONS	

PITCO FRIALATOR, INC.
P.O. BOX 501 CONCORD, NH 03302-0501

SCHMATIC, TF2000

PART NO: **D700268C**

SCALE: SH 1 OF 3

DATE: 10/29/96

REV: 1

APPD: BH

THE INFORMATION CONTAINED ON THIS DOCUMENT IS THE PROPERTY OF PITCO FRIALATOR, INC. AND MAY NOT BE REPRODUCED OR TRANSMITTED IN ANY FORM OR BY ANY MEANS WITHOUT THE WRITTEN PERMISSION OF PITCO FRIALATOR, INC. CONCORD, NH 03302-0501 U.S.A.

1

2

3

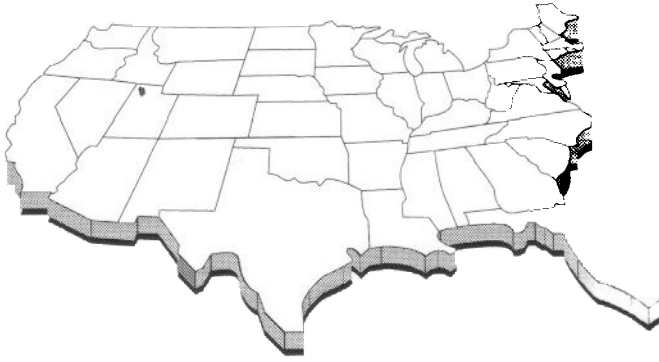

In the event of problems with or questions about your equipment, please contact your local ASAP (Authorized Service and Parts) representative. You can find their number by calling the:

NATIONAL SERVICE COOPERATIVE
1(800)298-1862

To obtain copies of this Installation, Operators and Maintenance Manual at NO CHARGE please contact Pitco Frialator at the following address:

**Pitco Frialator Inc.,
P.O.BOX 501
CONCORD, NH 03302-0501**

In the event of problems with or questions about your order, please contact the Pitco Frialator factory, from 8:00 a.m. - 5:00 p.m., Eastern Standard Time, Monday through Friday,

(603)225-6684 World Wide