



IMPORTANT FOR FUTURE REFERENCE
Please complete this information and retain this manual for the life of the equipment:

Model #: _____
Serial #: _____
Date Purchased: _____

ENGLISH

Exploded Parts Manual

SSPG Gas Pasta Cooker





TO THE PURCHASER, OWNER AND STORE MANAGER

Please review these warnings prior to posting them in a prominent location for reference

TO THE PURCHASER

Post in a prominent location the instructions to be followed in the event that an operator smells gas. Obtain this information from your local gas supplier.

WARNING

DO NOT store or use gasoline or other flammable vapors and liquids in the vicinity of this or any other appliance.

WARNING

Improper installation, alteration, service or maintenance can cause property damage, injury or death. Read the installation, operating and maintenance instructions thoroughly before installing or servicing this appliance.

WARNING

Installation, maintenance and repairs should be performed by a Pitco Authorized Service and Parts (ASAP) company technician or other qualified personnel. Installation, maintenance or repairs by an unauthorized and unqualified personnel will void the warranty.

WARNING

Installation and all connections must be made according to national and local regulations and codes in force.

WARNING

During the warranty period if a customer elects to use a non-original part or modifies an original part purchased from Pitco and/or its Authorized Service and Parts (ASAP) companies, this warranty will be void. In addition, Pitco and its affiliates will not be liable for any claims, damages or expenses incurred by the customer which arises directly or indirectly, in whole or in part, due to the installation of any modified part and/or received from an unauthorized service center.

WARNING

This appliance, when installed, must be electrically grounded in accordance with local codes, or in the absence of local codes, with the National Electrical Code, ANSI/NFPA 70, or the Canadian Electrical Code, CSA C22.2, as applicable.

WARNING

Adequate means must be provided to LIMIT the movement of this appliance without depending on the gas or electrical cord connection. Single appliances equipped with legs must be stabilized by installing anchor straps. All appliances equipped with casters must be stabilized by installing restraining chains.

WARNING

An appliance equipped with casters and a flexible gas line must be connected to the gas supply with a quick disconnect device. This quick disconnect must comply with ANSI Z24.41.

WARNING

DO NOT alter or remove structural material on the appliance to accommodate placement under a ventilation hood.

WARNING

This appliance is intended for professional use only and should be operated by fully trained and qualified personnel.

WARNING

If the appliance is equipped with a power cord and it is damaged, it must be replaced by a Pitco Authorized Service and Parts (ASAP) company technician, or a similarly qualified person in order to avoid a hazard.

WARNING

The power supply must be disconnected before servicing, maintaining or cleaning this appliance.

WARNING

The appliance is NOT jet stream approved. DO NOT clean the appliance with a water jet.

Exploded Parts-SSPG Gas Model

WARNING

DO NOT attempt to move this appliance or transfer hot liquids from one container to another when the unit is at operating temperature or filled with hot liquids. Serious personal injury could result if skin comes in contact with the hot surfaces or liquids.

WARNING

DO NOT sit or stand on this appliance. The appliance's front panel, tank, splash back, tank cover, workshelf, drain board is not a step. Serious injury could result from slipping, falling or contact with hot liquids.

WARNING

NEVER use the appliance as a step for cleaning or accessing the ventilation hood. Serious injury could result from slips, trips or from contacting hot liquids.

WARNING

The water level should be maintained at the level line. DO NOT turn the appliance on until the heat tubes are fully covered with water at all times. Serious injury could result from hot steam vapors off the heat tubes.

WARNING

If overflow drain is not equipped or if overflow drain stop is used, do not leave appliance unattended while filling with water. Over filling the appliance can cause serious injuries and damage the equipment.

WARNING

Completely shut the appliance down when the water is being drained from the appliance. This will prevent the appliance from heating up during the draining and filling process. Serious injury can occur.

WARNING

This appliance is intended for indoor use only.

WARNING

DO NOT operate appliance unless all panels and access covers are attached correctly.

WARNING

It is recommended that this appliance be inspected by a qualified service technician for proper performance and operation on a yearly basis.

WARNING

There is an open flame inside this appliance. The unit may get hot enough to set nearby materials on fire. Keep the area around the appliance free from combustibles.

WARNING

DO NOT supply the appliance with a gas that is not indicated on the data plate. If you need to convert the appliance to another type of fuel, contact your dealer.

WARNING

DO NOT use an open flame to check for gas leaks!

WARNING

If gas flow to appliance is interrupted, or pilots extinguish, wait 5 minutes before attempting to relight the pilot to allow any residual gas in appliance to dissipate.

WARNING

Ensure that the appliance can get enough air to keep the flame burning correctly. If the flame is starved for air, it can give off a dangerous carbon monoxide gas. Carbon monoxide is a clear odorless gas that can cause suffocation.



NOTICE

IN THE EVENT OF PROBLEMS OR QUESTIONS ABOUT YOUR ORDER, CONTACT THE PITCO FRIALATOR FACTORY AT (603) 225-6684.

IN THE EVENT OF PROBLEMS OR QUESTIONS ABOUT YOUR EQUIPMENT, CONTACT THE PITCO FRIALATOR AUTHORIZED SERVICE AND PARTS REPRESENTATIVE (ASAP) COVERING YOUR AREA, OR CONTACT PITCO AT THE NUMBER LISTED ABOVE.

MAILING ADDRESS

PITCO FRIALATOR
P. O. BOX 501
CONCORD, NH 03302-0501

SHIPPING ADDRESS

PITCO FRIALATOR
10 FERRY STREET
CONCORD, NH 03301

TABLE OF CONTENTS

A) TANK & FLUE4
 TANK & FLUE EXPLODED PARTS LIST/VIEW4

B) BURNER ASSEMBLY5
 BURNER ASSEMBLY EXPLODED PARTS LIST/VIEW.....5

C) GAS TRAIN6
 GAS TRAIN DRAWING PARTS LIST6

D) GAS CONVERSION KITS.....7
 GAS CONVERSION KITS QUICK REFERENCE7

E) STANDARD CABINET DRAWING8
 STANDARD CABINET DRAWING LIST8
 STANDARD CABINET PARTS DRAWING.....9

F) ACCESSORIES.....10
 ACCESSORIES DRAWING PARTS.....10

A) TANK & FLUE

Tank & Flue Exploded Parts List/View

BOM TABLE			
ITEM NO.	PART NO.	DESCRIPTION	QTY
1	B3330702	TANK, WELDMENT	1
2	B3505601	FLUE, WELDMENT	1
3	60148604	VALVE, BALL 1.250" FULL PORT STAINLESS	1
4	PP10023	SCREW, 10-24 X .375 SELF TAPPING	4
5	A1402202	CLAMP, BULB LIMIT 316 SS	1
6	PP10568	NUT, WING 10-24 SS	2

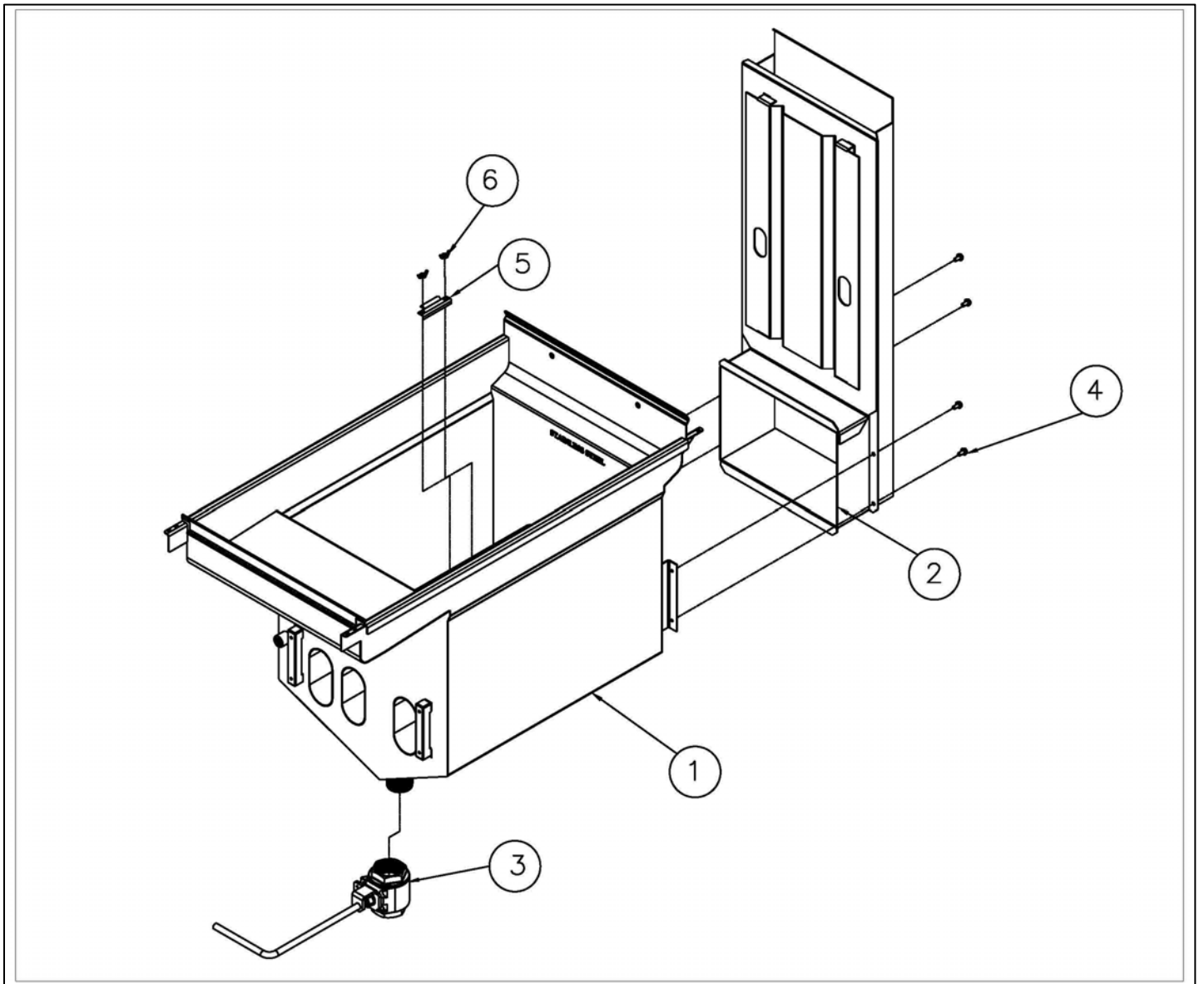

B) BURNER ASSEMBLY

Burner Assembly Exploded Parts List/View

BOM TABLE				
ITEM NO.	PART NO.	DESCRIPTION	NAT QTY	LP QTY
1	A8042301	PIPING, BURNER BRACKET	1	1
2	B8041901	PIPING, BURNER INCONEL 601 SCREEN	3	-
	B8046101	PIPING, BURNER INCONEL 20X20 SCREEN	-	3
3	B8046301	PIPING, BURNER MANIFOLD WELDMENT	1	1
4	60127501	FITTING, ADAPTER MALE FLARE X .500 FPT	1	1
5	60129701	FITTING, BURNER	3	3
6	N/A	1/8 NPT 3/16 HEX SOCKET HEAD PLUG	1	1
7	A8031601	PIPING, CROSSOVER	1	1
8	A803171	PIPING, BURNER SHIELD LH	1	-
	A8034901	PIPING, BURNER LP SHIELD LH	-	1
9	A8031801	PIPING, BURNER SHIELD	1	-
	A8034905	PIPING, BURNER LP SHIELD	-	1
10	PP10023	SCREW, 10-24 X .375 SELF TAPPING HEX HD SLTD	5	5
11	PP10174	STUD, WELD FLANGED 10-24 UNC X 375	8	8
12	P0092300	NUT, HEX KEP 10-24 ZN	6	6
13	A8043201	PIPING, BURNER RETAINER BRACKET	3	4

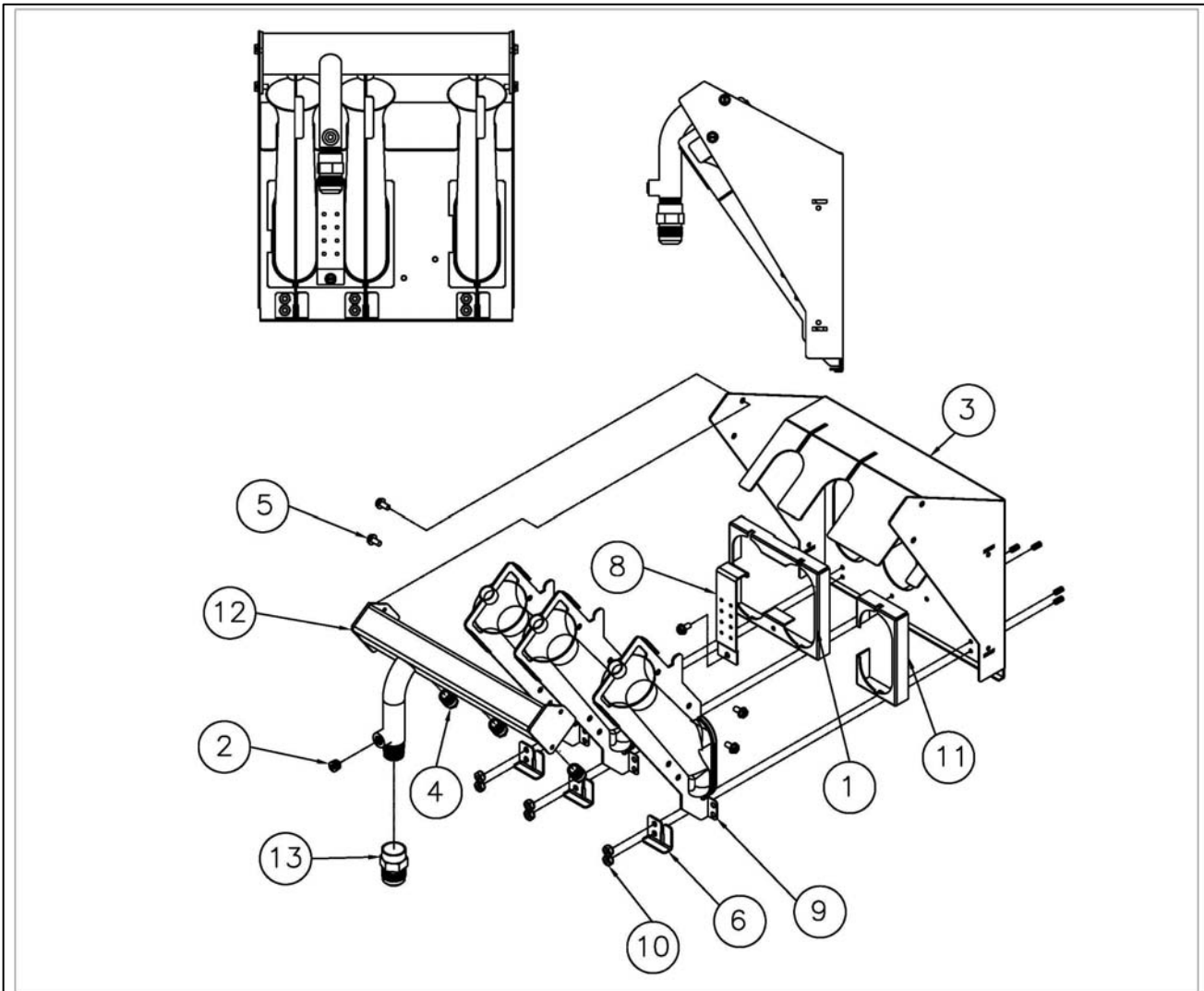

C) GAS TRAIN

Gas Train Drawing Parts List

BOM TABLE				
ITEM NO.	PART NO.	DESCRIPTION	NAT 24V QTY	LP 24V QTY
1	60125901	TUBE, VENT GAS VALVE	1	1
2	60127601	FITTING, APAPTER FEMALE SWIVEL X 500 NPT	2	2
3	A8043501	PIPING, VALVE SHIELD HE PASTA	1	1
4	60127401	FITTING, ELBOW MALE FLARE X MALE PIPE THREAD	2	1
5	P0007300	SCREW, 8-32 X .250 HEX HEAD SLOTTED ZN	3	3
6	A8029105	COUPLING, GAS SUPPLY SHORT	1	1
7	60113501	VALVE, GAS VR8204 24V FAST NAT	1	-
8	60128101	VALVE, GAS SUPPLY SHUTOFF	1	1
9	6012816	TUBING, FLEXIBLE WITH FITTINGS 28 GAS	1	1
10	PP10687	SCREW, 6-32 X 313 THRUSS HEAD PHILLIPS ZN	2	2
11	PP10803	SWITCH, HI-LIMIT 250F LB117-026	1	1
12	A8043601	BRACKET, HI LIMIT PSG	1	1
13	P0075400	SCREW, 10-24 X .500 SELF TAPPING	2	2
14	B6745502	WIRING, HI-LIMIT 24VAC (NOT SHOWN)	1	1
15	60113502	VAVLE, GAS VR8204 24V FAST LP	-	1

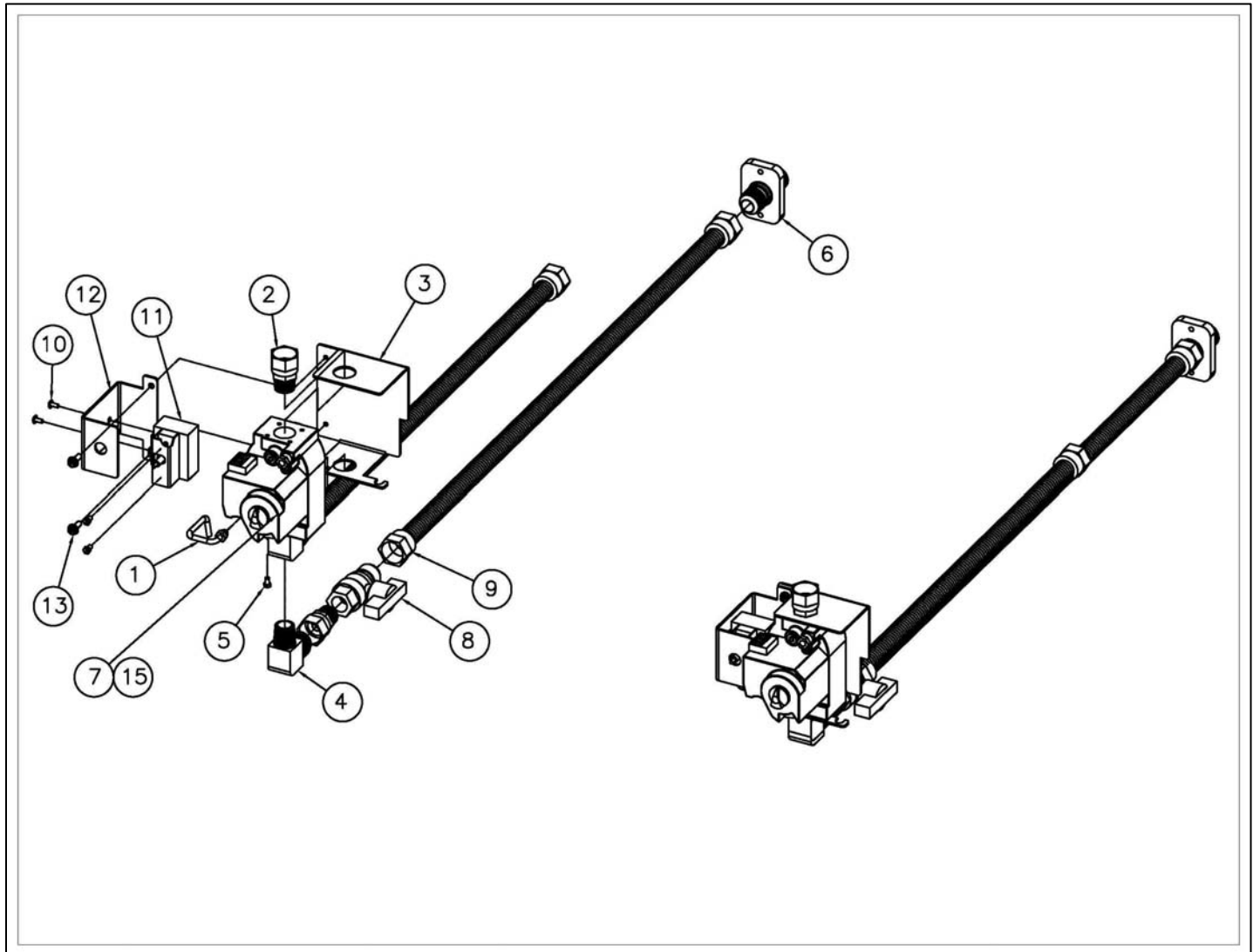



D) GAS CONVERSION KITS

Gas Conversion Kits Quick Reference

NATURAL TO LP			
ITEM #	PART #	PART DESCRIPTION	QTY
1	B8043250-C	PG, CONV SSPG NAT TO LP	
	2908-0940502	ORF, PILOT RNR TUBE #68	1
	P6071665	ORF, SPUD LP .016[0.40]	1
	PP10426	LBL, GAS NOTICE CVRSN LP	1
	PP11141	VLV, CONV KIT VR8204 NAT TO LP	1
	A8034905	PG, COLLAR BNR LP ST MG, SGH	2
	B8046101	PG, BNR INC 600, 20X20 SCRN	2
	P6071353	ORIFICE #53	2
LP TO NATURAL			
ITEM #	PART #	PART DESCRIPTION	QTY
1	B8043251-C	PG, CONV SSPG LP TO NAT	
	2908-0940501	ORF, PILOT RNR TUBE #52	1
	P6071666	ORF, SPUD NAT .022[0.55]	1
	PP10427	LBL, GAS NOTICE CVRSN NAT	1
	PP11319	VLV, CONV KIT VR8204 LP TO NAT	1
	A8031801	PG, BNR SHLD SG14T*	2
	P6071342	ORIFICE #42	2

E) Standard Cabinet Drawing

Standard Cabinet Drawing List

BOM TABLE			
ITEM NO.	PART NO.	DESCRIPTION	QTY
1	A1537002	CABINET SIDE, LH HE PASTA GAS	1
2	A1537004	CABINET SIDE, RH HE PASTA GAS	1
3	A1537102	CABINET SIDE, SUPPORT HE PASTA MOD	2
4	A1638202	CABINET BACK,BOTTOM HE PASTA 14	1
5	A1638101	CABINET BACK, TOP SSPG14	1
6	A1853201	CABINET, SPACER HE PASTA 14	1
7	P0075400	SCREW, 10-24 X .500 SELF TAPPING	58
8	A1853601	CABINET, SPACER SOLSTICE GAS PASTA 14	1
9	P0020600	SCREW, .250-20 X .625 HEX HEAD ZN	16
10	P0093300	NUT, HEX KEP .250-20 ZN	16
11	60132401	LEG, ADJUSTABLE 9" POWDER COATED	4
12	A1234301	CABINET BOTTOM BRACE, FRONT	1
13	B3636203	FRONT PANEL, BEZEL ASSEMBLY COMPACT DIGITAL	1
14	B3636501	FRONT PANEL, TOP DECK WELDMNT	1
15	A3679002	FRONT PANEL, BOTTOM HE PASTA	1
16	A3678802	FRONT PANEL, END CAP	2
17	B2304616	DOOR, ASSEMBLY	1
18	B3802401	HINGE, WELDMENT UPPER RH	1
19	B3801801	HINGE, WELDMENT LOWER RH	1
20	A3679102	FRONT PANEL, LOWER SSPG14 T&S MX VLV	1
21	A1847002	CLIP, BRACKET MAGNET CATCH	1
22	P6071300	CATCH, MAGNET STANDARD	1
23	B2006102	CONTROL BOX ASSEMBLY	1
24	A4110902	SPLASH BACK, HE PASTA T&S	1
25	60132001	TANK, STUD SPLASH BACK SCREW ON	2
26	60125801	SCREW, 10-24 X .375 THRUSS HEAD SLOTTED SST	2
27	A1108002	BASKET HANGER, HEMMED HE PASTA	1
28	A1236502	CABINET, BOTTOM SHELF HE PASTA RH	1
29	A1236504	CABINET, BOTTOM SHELF HE PASTA LH	1

Standard Cabinet Parts Drawing

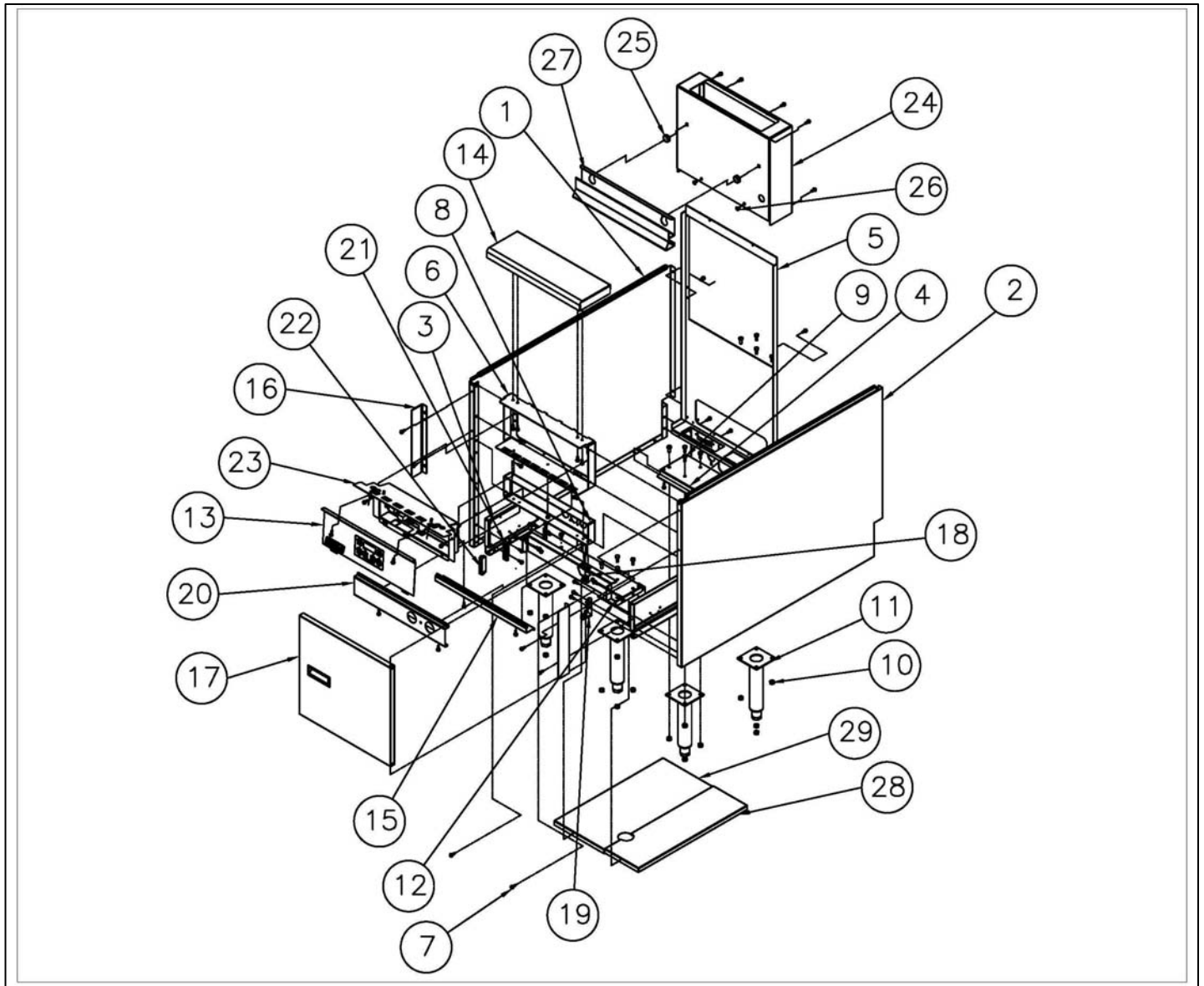

F) ACCESSORIES

Accessories Drawing Parts

ITEM #	PART #	PART DESCRIPTION
1	A3305701	CLEAN-OUT ROD
2	PP10730	BRUSH,NYL FRYER-CLNR STR 416T
3	60132401	9" LEG
4	B392102	9" LEG SET OF 4 WITH HARDWARE (NOT SHOWN)
5	60115301	9" LEG WITH BOTTOM BOLT FLANGE ADJUSTABLE (NOT SHOWN)
6	PP10814	9" CASTER NON-LOCKING
7	PP10815	9" CASTER LOCKING
8	B3901504	9" CASTER SET OF 4 (2 LOCKING, 2 NON-LOCKING) (NOT SHOWN)
9	A1108001	BASKET HANGER, HEMMED HE PASTA
10	B4510101	WR/G,RACK PASTA BSKT PG14D,PPG
11	B4510001	WR/G,BSKT PST RND 4-7/8 REG
12	B4512702	WR/G,BSKT PST LG BULK FINE MSH
13	B4509901	WR/G,BSKT PST RND 6-1/2 REG
14	B4510202	WR/G,BSKT PST SM BULK FINE MSH
15A	B9010006	SET IND SERV BSKTS W/RACK
15B	P6071998	IND SERVING BASKET
16	B4509801	OBLONG BASKET

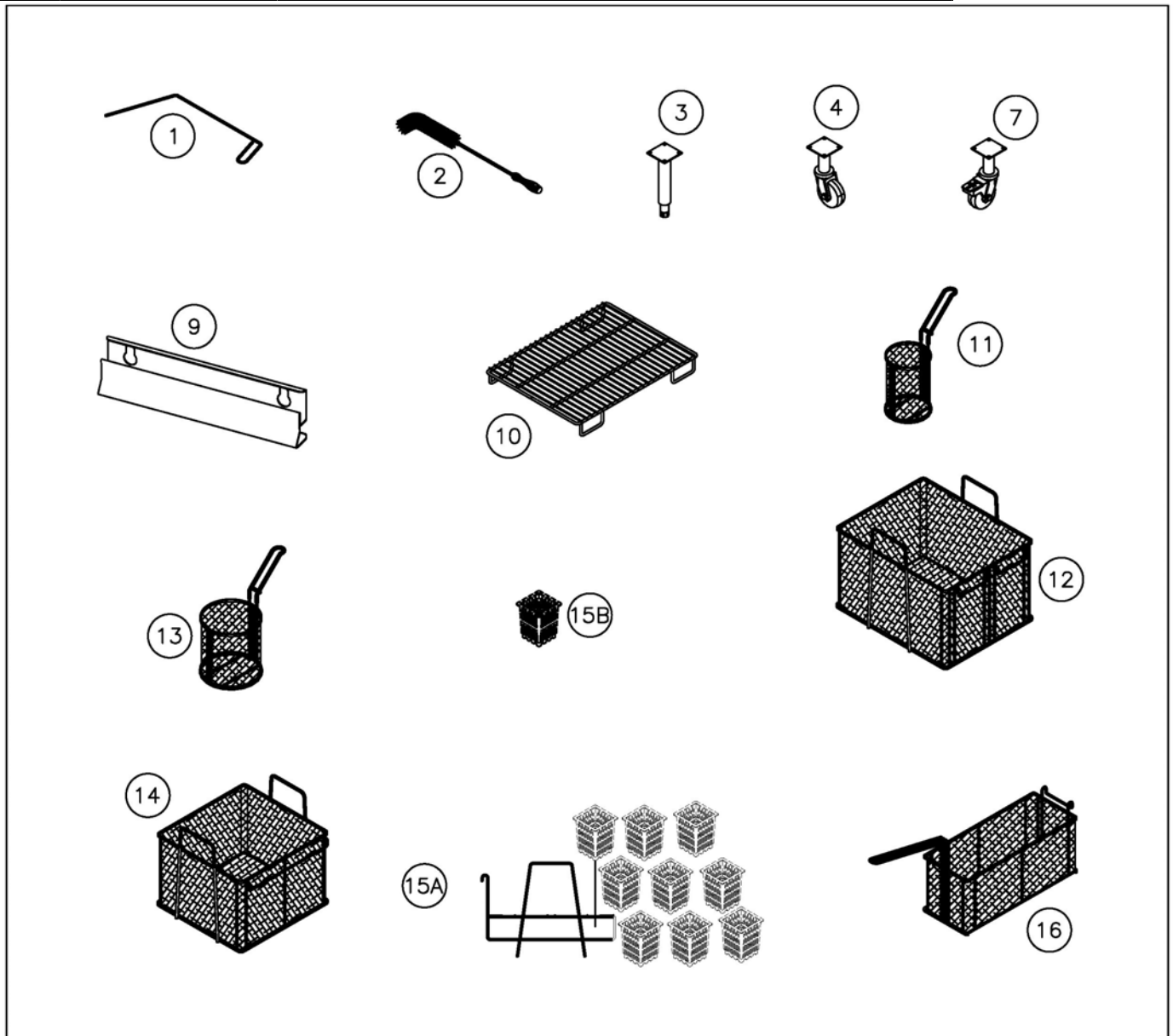

NOTES



In the event of problems with or questions about your order, please contact the Pitco Frialator factory at

(603) 225-6684 World Wide
www.pitco.com

In the event of problems with or questions about your equipment, please contact the Pitco Frialator Authorized Service and Parts representative (ASAP) covering your area, or contact Pitco at the numbers listed to the left.

MAILING ADDRESS – P.O. BOX 501, CONCORD, NH 03302-0501
SHIPPING ADDRESS – 10 FERRY ST., CONCORD, NH 03301