

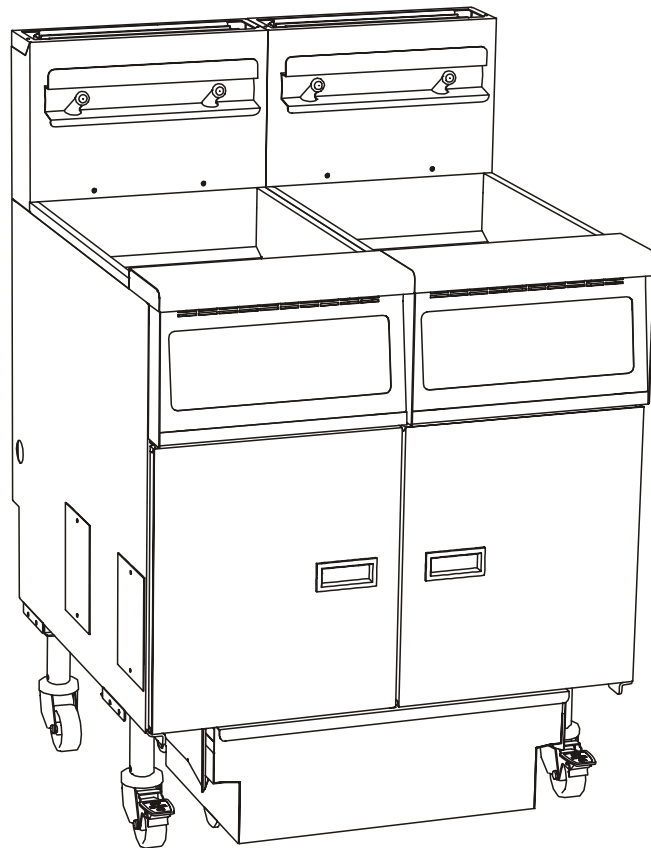

Technical Service and Exploded Parts
For Gas Fryers
Covering Models
SGH50 Full and Twin



WARNING! FIRE HAZARD

THE OIL LEVEL SHOULD NOT FALL BELOW THE MINIMUM INDICATED LEVEL AT ANY TIME. THE USE OF OLD OIL CAN BE DAGEROUS AS IT WILL HAVE A REDUCED FLASH-POINT AND BE MORE PRONE TO SURGE BOILING.

WARNING

INSTALLATION AND ALL CONNECTIONS MUST BE MADE ACCORDING TO NATIONAL AND LOCAL REGULATIONS AND CODES IN FORCE.

WARNING

A COUNTRY APPROVED ALL POLE CIRCUIT BREAKER WITH A MINIMUM OPEN CONTACT GAP OF 3mm MUST BE USED FOR PROPER INSTALLATION.

WARNING

THE FRYER IS NOT JET STREAM APPROVED. DO NOT CLEAN THE APPLIANCE WITH A WATER JET.

NOTICE

INSTALLATION SHOULD ONLY BE DONE BY A COMPETENT SERVICE TECHNICIAN. THE MODEL & SERIAL NUMBER, AND ELECTRICAL REQUIREMENTS STAMPED INTO THE DATA PLATE, LOCATED ON THE INSIDE PANEL OF THE DOOR.

NOTICE

THIS APPLIANCE IS INTENDED FOR PROFESSIONAL USE ONLY, AND AS SUCH, SHOULD BE OPERATED BY FULLY TRAINED PERSONNEL.

NOTICE

IT IS RECOMMENDED THAT THIS MACHINE BE INSPECTED BY A QUALIFIED TECHNICIAN ON A YEARLY BASIS.

WARNING

THE POWER SUPPLY MUST BE DISCONNECTED SERVICING OR CLEANING THE UNIT.

WARNING

SHORTENING, WHEN IT IS AT OPERATING TEMPERATURES, IS VERY HOT AND DANGEROUS! USE EXTREME CAUTION WHEN HANDLING! USE PROPER PROTECTIVE GEAR SUCH AS INSULATED GLOVES, APRONS, FACE SHIELD, AND SLEEVES WHEN HANDLING HOT SHORTENING. DO NOT ATTEMPT TO MOVE MACHINE THAT HAS HOT OIL IN IT. ALLOW TO COOL TO ROOM TEMPERATURE OR DRAIN THE OIL INTO A SUITABLE CONTAINER BEFORE MOVING THE FRYER.

Table of Contents

How Does It Work? 4

Component Troubleshooting..... 4

Temperature Probe Resistance Chart 5

Basic Trouble Shooting 8

Relay Board Component Explanation 10

Ladder Diagram 13

Schematics 14-19

Basic Parts List 21

Exploded Drawings 22-31

Front Panel and Tank Components 22

Pump Box and Drain Manifold 24

Main Entrance Box and Gas Components 26

Pump Assembly and Filter Pan 28

Wire Harness? 30

Chapter 1: HOW DOES IT WORK?

The SGH50 fryer components function in specific order of operation. Knowing and understanding the sequence of fryer and components operation will enable you to diagnose equipment failure more accurately.

Heating System

Power to the machine is turned ON:

- If Fuse F1 on the Relay board is good, the A.C. indicator will illuminate and the controller will be supplied with 24 VAC and, if the drain valve handle is closed, the proximity switch will supply 24 VAC to the DVI (drain valve interlock) input at the controller.
- The computer or solid state control is turned ON:
- The side on relay will be energized, closing the circuit and the S.O. indicator on the Relay Board will illuminate. If the hi limit is NOT tripped the ignition module will receive 24VAC at terminal 6 (24 VAC).
- The ignition module will have a 24 VAC output from terminal 3(PV) to the PV terminal on the gas valve and the ignitor will spark. When the pilot has lit and the module has proven the pilot flame, it will have a 24 VAC output at terminal 1(MV) and put 24 VAC on pin #2 at connection J/P32 on the relay board. The heat demand relay on the relay board will interrupt the 24 VAC supply to the gas valve until the controller calls for heat.
Note: When the controller is on, the pilot should always remain lit.
- Controller calls for heat:
- The heat demand relay will energize supplying the gas valve with 24 VAC and the H.D. indicator on the Relay Board will illuminate. This will also supply the computer with a heat feedback signal.

Hi Limit System:

- If the hi limit trips, it interrupts the 24 VAC supply to the ignition module. When the controller calls for heat, it will not receive a 24 VAC heat feed back. With approximately 90 seconds of heat feed back loss, the controller will indicate an ignition failure or heat failure. After the hi limit is reset (unit cools to 400°F ± 20°F) the computer will have to be turned off and back on for the unit to heat.

Filter System:

- Opening the RED return valve handle will close the proximity switch causing the "pump run" relay to be energized. The pump motor will begin to run. Closing the return valve handle will de-energize the relay and the pump motor will stop running.
- The pump system is equipped with a circuit breaker which will de-energize the system and the heat tape in the event of over current. The circuit breaker switch must be in the ON position for the pump and heat tape to operate.
- The return piping system may be provided with optional heat tape to prevent solidification of solid shortening. The heat tape is low wattage and is on constantly to maintain liquid shortening in the line.

Optional Basket Lift:

- The basket lift is a self contained unit that requires a 120, 208 or 240V supply. With most fryer configurations, the power is supplied from the entrance box at the back of the fryer but some configurations will require power direct from a wall outlet. When power is supplied to basket lift assembly, the baskets will lift to the up position. The baskets will lower with a 24 VDC output from the controller.

Chapter 2: COMPONENT TROUBLESHOOTING:

Probe:

The resistance of the probe will change as the temperature changes. The resistance will decrease as the temperature rises.

If the probe is suspect, check its resistance and the oil temperature at which it was taken. Compare these values on the probe resistance chart.

If the probe returns an open circuit or 0 Ohms reading, it should be replaced. If the resistance varies more than 30 Ohms when being checked between 325-375°F the probe will give a false temperature reading on the computer and should be calibrated (up to 10°F) or replaced. However, it will continue to operate at a slightly higher or lower temperature.

TEMP °F/°C	RESISTANCE OHMΩ	TEMP °F/°C	RESISTANCE OHMΩ
60/16	139,055	330/166	1,192
80/27	84,644	335/168	1,123
100/38	53,146	340/171	1,058
120/49	34,328	345/174	998
140/60	22,755	350/177	942
160/71	15,446	355/179	890
180/82	10,716	360/182	841
200/93	7,586	365/185	795
210/99	6,427	370/188	752
220/104	5,470	375/191	712
240/116	4,013	380/193	675
260/127	2,991	385/196	640
280/138	2,262	390/199	607
300/149	1,734	395/202	576
320/160	1,347	400/204	547
325/163	1,267		

Allow the oil to cool and check the probe resistance at a lower temperature. As can be seen from the chart a greater variation can be tolerated at a lower temperature.

Gas Valve:

The gas valve has a dual 24 VAC operator and will open when the correct voltage is supplied to the operator. With 24 VAC applied to the PV (24 VAC) connection, the pilot valve operator will open, allowing gas to flow to the pilot.

With 24 VAC applied to the MV (24 VAC) connection, the main valve operator will open, allowing gas to flow to the main burners.

Hi Limit:

The hi - limit switch is a normally closed switch until the temperature at the hi-limit bulb reaches 450°F ± 15°F.

WARNING!

This test should be performed by a qualified technician only! Monitor the fryer closely. This test will cause the oil to heat past the normal operating temperature and can cause damage to the machine and its operator if care is not taken.

WARNING!

This test will cause the burners to run continuously. Remove test resistor when test is complete. Leaving the test resistor in the fryer could cause damage to equipment and/or personal injury.

To test the hi-limit, use a 2kΩ - 5kΩ resistor to simulate a 230°F - 275°F temperature. This will cause the burners to run continuously until the hi-limit trips or the fryer is turned off.

•If the fryer is equipped with a **computer or digital controller**, plug the resistor in at connector J41 behind the front panel.

•If the fryer is equipped with a **solid state controller** behind the door, plug the resistor in at connector J43 behind the front panel.

If the switch does not trip between the prescribed limits it is defective and should be replaced. Once tripped, the switch cannot be reset until the oil has cooled to approximately 400°F ± 20°F. If the switch does not reset after oil has cooled it is defective.

Drain Valve & Return Valve Switches:

These switches are a magnetically operated proximity switches. When the Drain Valve handle is moved to the open position, the Actuator will move away from the switch causing the switch to open. When the Drain Valve is closed the switch will close.

Opening the RED return valve handle will close the proximity switch causing the "pump on" relay to be energized. The pump will begin to pump. Closing the return valve handle will open the proximity switch causing the relay to de-energize and the pump will stop pumping. These switches can also be checked with an Ohm meter. When the switch is closed, you should have continuity. The normal gap between the Actuator and the Sensor switch on the valve handle is 1/8" - 1/4" (3 - 6mm).

Transformer:

The transformer is a multiple AC input voltage 24 VAC output voltage and can be checked by reading the input and output voltages. A quick check for 24 VAC can be done at the relay board behind the front panel. The AC

indicator will be illuminated if the F1 fuse is good and the board is receiving 24 VAC.

Ignition Module:

With a 24 VAC input at pin #6, the ignition module will have a 24 VAC output from terminal 3(PV) and the ignitor will spark until the module senses pilot flame or for approximately 90 seconds at which time the module will lock out, whichever occurs first. When the module has proven the pilot flame, it will have a 24 VAC output at terminal 1(MV) and put 24 VAC to pin 2 at connection J/P32 on the relay board. The relay board will interrupt the 24 VAC to the gas valve until the controller calls for heat.

Note: When the controller is on, the pilot should always remain lit.

Relay Board:

Note: J connectors are marked on the relay board.

•With 24 VAC supplied to pin #2 at connector J35 and a good F1 fuse, the relay board will have a 24 VAC output at pin #2 on connectors J33 and J34 and the A.C. indicator will be illuminated.

Note: If the fryer is equipped with a computer or solid state digital, at connection J33 there will be a jumper from pin #2 to pin #10 to supply 24 VAC to pin # 2 at connection J31 to supply the controller with 24VAC.

•When the board receives a 24 VDC side on input at pin #7 on connectors J31 or J33, the S.O. indicator will illuminate, the side on relay (S.O.) will energize and there will be a 24 VAC output at pin #4 on connector J32.

•When the board receives a 24 VDC heat demand input at pin #6 on connectors J31 or J33, the H.D. indicator will illuminate, the heat demand relay (H.D.) will energize and there will be continuity between pin #1 and pin #2 at connector J32.

Computer Control:

Note: All controller test points are at connector P/J1 (closest connector to the controller).

•With 24 VAC supplied to pin #1(24VAC supply) and pin # 5(24VAC input from DVI), the display should read "OFF".

•With the controller turned on, there will be a 24 VDC

output at pin #9 (side on).

•When the controller calls for heat, there will be a 24 VDC output at pin #8 (heat demand) and a 24 VAC input at pin #6 (heat feed back). If the controller does not receive the 24 VAC input at pin #6 in approximately 90 seconds, the controller will display "HEAT FAIL" or "IGNITION FAILURE". This would indicate a break in the heat demand or heat feed back circuit.

1. Check the hi-limit switch (is it open or tripped).
2. Check the ignition module (sensing pilot flame, locked out, 24 VAC at MV terminal).
3. Check the heat demand relay (H.D.) on the relay board (is heat demand relay energized, continuity through COM and NO contacts).

•If display reads "PROBE OP" "OPEN", ohm test the temperature probe. Check the wires and connectors between the probe and controller for continuity.

•If display reads "SYSTEM" "FAILURE", test the temperature probe and the wires and connectors between the probe and controller for a short.

•If display reads "DRAINING" "TURN OFF", verify that the drain valve is closed, check the proximity switch on the drain valve, turn the fryer off, then turn the fryer on.

Digital Solid State Control:

Note: All controller test points are at connector P/J1 (closest connector to the controller).

•With 24 VAC supplied to pin #1(24VAC supply) and pin # 5(24VAC input from DVI), the display should read "OFF".

•With the controller turned on, there will be a 24 VDC output at pin #9 (side on).

•When the controller calls for heat, the display will read "HEAt", there will be a 24 VDC output at pin #8 (heat demand) and a 24 VAC input at pin #6 (heat feed back). If the controller does not receive the 24 VAC input at pin #6 in approximately 90 seconds, the controller will display "HEAt" "FAIL" . This would indicate a break in the heat demand or heat feed back circuit.

1. Check the hi-limit switch (is it open or tripped).
2. Check the ignition module (sensing pilot flame, locked out, 24 VAC at MV terminal).
3. Check the heat demand relay (H.D.) on the relay board (is heat demand relay energized, continuity through COM and NO contacts).

•If display reads "Prob", ohm test the temperature probe. Check the wires and connectors between the probe and

controller for continuity.

- If display reads "Prob" "HI", ohm test the temperature probe and the wires and connectors between the probe and controller for a short.

- If display reads "drn" "tUrn" "oFF", verify that the drain valve is closed, check the proximity switch on the drain valve.

Primary Solid State Control:

Note: All controller test points are at connector P/J3 (the 12 pin connector at the controller).

- 24 VAC is supplied to the controller at pin #1(24VAC supply) and pin # 5 (24 VAC input from DVI),

- With the controller turned on, there will be a 24 VDC output at pin #9 (side on) and the green indicator will be illuminated.

- When the controller calls for heat, there will be a 24 VDC output at pin #8 (heat demand), the yellow indicator on the left will be illuminated and there will be a 24 VAC input at pin #6 (heat feed back).

- When the controller receives the 24 VAC input at pin #6, the yellow indicator on the right will illuminate. If the controller does not receive the 24 VAC input at pin #6, the indicator will not illuminate. This would indicate a break in the heat demand or heat feed back circuit.

1. Check the hi-limit switch (is it open or tripped).
2. Check the ignition module (sensing pilot flame, locked out, 24 VAC at MV terminal).
3. Check the heat demand relay (H.D.) on the relay board (is heat demand relay energized, continuity through COM and NO contacts).

- If the green indicator and the yellow indicator on the left come on and shut off when the controller is turned on, that indicates an open or shorted probe or wires in between the probe and the controller.

- If none of the indicators illuminate when the controller is turned on, verify that the drain valve is closed and that the magnetic proximity switch has continuity when the drain valve is closed. Also verify that there is 24 VAC at pin #1 (24 VAC supply) and pin #5 (24 VAC input from DVI).

Backup Solid State Control:

The backup solid state control works the same as the primary solid state control, with the exception of the 24 VAC supply passing through the solid state backup transfer switch to the computer or solid state digital control.

If the transfer switch is set to backup or if the backup

controller has been unplugged, the primary controller will not work. The jumper must be installed on the relay board (connection J33) to allow the primary controller to function if the backup controller is removed.

Optional Basket Lift:

- The basket lift is a self contained unit that requires a 120, 208 or 240V supply. With most fryer configurations, the power is supplied from the entrance box at the back of the fryer but some configurations will require power direct from a wall outlet.

- When supply voltage is applied to the basket lift assembly, it goes through a voltage selector switch to a multi tap 24V, 80VA transformer. The transformer supplies 24 VAC to the driver board at connection J54.

Note: When power is supplied to basket lift assembly, the baskets will lift to the up position.

- When a timer is activated, it will send a 24 VDC signal to pin #1 (24 VDC+) at connector J51 on the driver board. The driver board will generate a 24 VDC output at J53 to the basket lift motor, lowering the basket.

Note: For the purpose of testing, jumping pins #1 and #2 at connection J5 on the driver board will simulate a 24 VDC signal from the controller, lowering the basket.

Fryer Trouble Shooting

PROBLEM	POSSIBLE CAUSE	ACTION
Controller will NOT turn ON Display does NOT light	A. No power to the machine B. F1 Fuse blown C. T1 Transformer	A. Check building circuit breaker, verify power cord is plugged in B. Check F1 Fuse. Replace if defective C. Check voltage in and out of T1
Controller indicates "IGNITION FAILURE" or "HEAT FAIL" and machine does NOT heat.	A. Hi limit tripped B. Heat demand relay C. Relay board	A. Once the oil temp has gone below 400°F ± 20°, the Hi-limit should reset automatically, if not, replace Hi-limit B. Check & replace if defective C. Check & replace if defective
Machine is heating slowly	A. Gas vavle not turned fully to the on position B. Gas shut-off (yellow handle) not fully open C. Quick disconnect not connected properly D. Low gas pressure	A. Verify that the gas valve is in the on position B. Verify that the yellow handle is fully open (inline with the gas line) C. Verify that quick disconnect is properly connected D. Call a qualified gas technicain
Oil is hotter or colder than computer /controller displays	A. Temperature calibration B. Probe C. Probe wiring terminals	A. Adjust temperature offset up to ±10°F B. Check & replace if defective C. Clean or repair terminals
Controller will not turn on or displays "DRAINING" or "TURN OFF"	A. Blue drain valve not fully closed B. Sensor switch C. Incorrect switch gap/alignment	A. Check position of handle B. Switch may be loose or have loose wires, replace if defective C. Check gap/alignment, replace if defective
Controller heat demand lights are lit, machine does not heat. HD & SO lights on relay board are lit.	A. K1 relay (relay board) B. Gas valve C. Ignition module	A. Check & replace if defective B. Check & replace if defective C. Check & replace if defective
Computer displays "PROBE FAILURE"	A. Shorted probe B. Open probe C. Probe wiring terminals	A. Check probe & replace if defective B. Check probe & replace if defective C. Clean or repair terminals

Filter Trouble Shooting

PROBLEM	POSSIBLE CAUSE	ACTION
Red return handle is pulled out, but no pump sound can be heard	<ul style="list-style-type: none"> A. Red return handle not completely open B. Filter circuit breaker may be tripped or in the off position C. Filter motor thermal overload may be tripped D. Sensor switch may be loose or defective E. Power cord unplugged or loose 	<ul style="list-style-type: none"> A. Pull on red return handle to make sure valve is completely open B. Reset the circuit breaker or press it to the on position C. Push the red reset button on the end of the motor D. Check that the switch is tight and that it has the correct gap. Replace if defective E. Check the power cord at the fryer entrance box and at the pump box and make sure that the power cords are plugged in and /or pushed in all the way
Drain valve is closed, computer has been reset, but computer still displays "DRAINING"	<ul style="list-style-type: none"> A. Blue drain valve not fully closed B. Sensor switch C. Incorrect switch gap/alignment 	<ul style="list-style-type: none"> A. Check position of handle B. Switch may be loose or have loose wires, replace if defective C. Check gap/alignment, replace if defective
Oil is returning to the vat slowly or not at all	<ul style="list-style-type: none"> A. Dirty filter paper B. Strainer cap dirty C. Filter pan not pushed in completely D. O-rings not sealing on pick up tube 	<ul style="list-style-type: none"> A. Change filter paper B. Remove strainer cap and clean it C. Push filter pan in D. Check & replace if defective
Air bubbles are in the oil being returned to the vat	<ul style="list-style-type: none"> A. Strainer cap not tight B. Strainer cap not in pick up tube C. Filter pan not pushed in completely D. O-rings not sealing on pick up tube 	<ul style="list-style-type: none"> A. Tighten strainer cap B. Install strainer cap C. Push filter pan in D. Check & replace if defective
Drain valve is open, the oil is draining slowly or not at all	<ul style="list-style-type: none"> A. Drain valve is not fully open B. Drain line is plugged with debris 	<ul style="list-style-type: none"> A. Apply a little more pressure to the drain valve handle to check that the drain valve is fully open B. Use the clean out rod to clear the drain valve opening. If this does not clear the blockage, close the drain valve, and call for service

Fuse:

Relay Board Component Explanation

F1 - If fuse is blown, A.C. will not be lit.

Trouble Shooting Lights:

A.C. - When lit, F1 Fuse and T1 Transformer are good.

S.O. - When lit, A1 Computer is on and K10 Contactor should be energized.

H.D. - When lit, A1 Computer is on and calling for heat, K11 Contactor should be energized

Relays:

K1 - Heat Demand Relay, will be energized when A1 Computer calls for heat and when H.D. is lit.

K3 - Side On Relay, will be energized when A1 Computer is on and A.C. is lit.

Connectors:

J31 - Connects to A1 Computer

J32 - To Side On and Heat Demand Contactors and Heat Feed Back.

J33 - To 24VAC jumper harness.

J34 - To Drain Switch and optional Basketlifts

J35 - Input voltage from transformer

Relay Board:

Note: J connectors are marked on the relay board.

•With 24 VAC supplied to pin #2 at connector J35 and a good F1 fuse, the relay board will have a 24 VAC output at pin #2 on connectors J33 and J34 and the A.C. indicator will be illuminated.

Note: If the fryer is equipped with a computer or solid state digital, at connection J33 there will be a jumper from pin #2 to pin #10 to supply 24 VAC to pin # 2 at connection J31 to supply the controller with 24VAC.

•When the board receives a 24 VDC side on input at pin #7 on connectors J31 or J33, the S.O. indicator will illuminate, the side on relay (S.O.) will energize and there will be a 24 VAC output at pin #4 on connector J32.

•When the board receives a 24 VDC heat demand input at pin #6 on connectors J31 or J33, the H.D. indicator will illuminate, the heat demand relay (H.D.) will energize and there should continuity between pin #1 and pin #2 at connector J32.

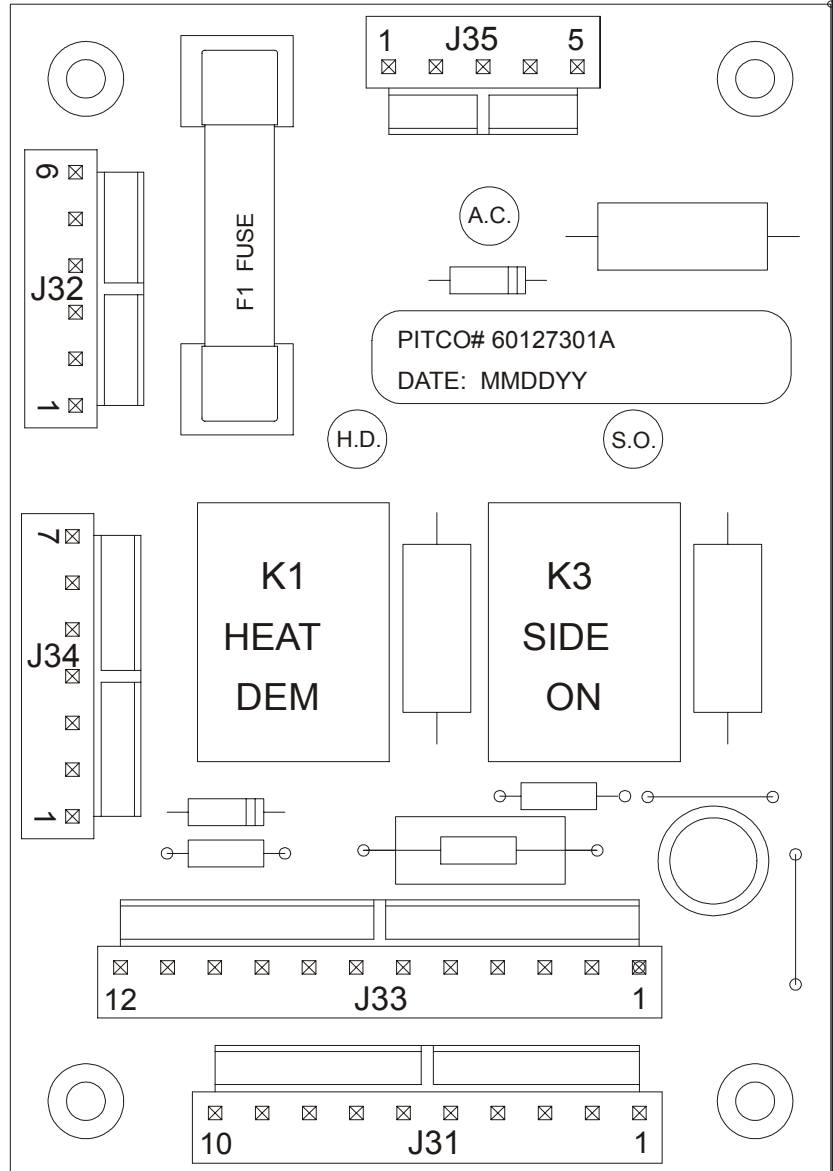

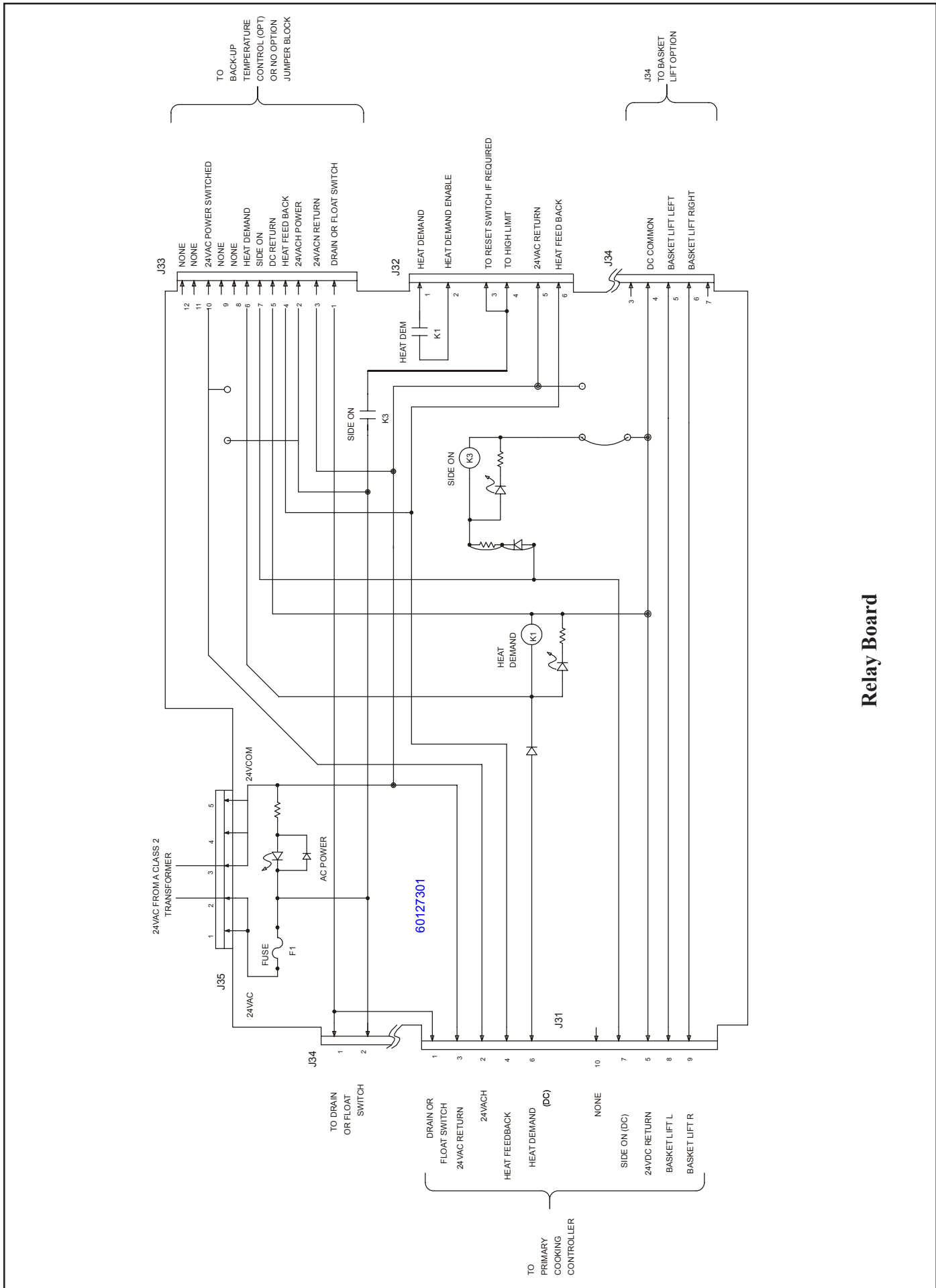

Relay Board

Schematics

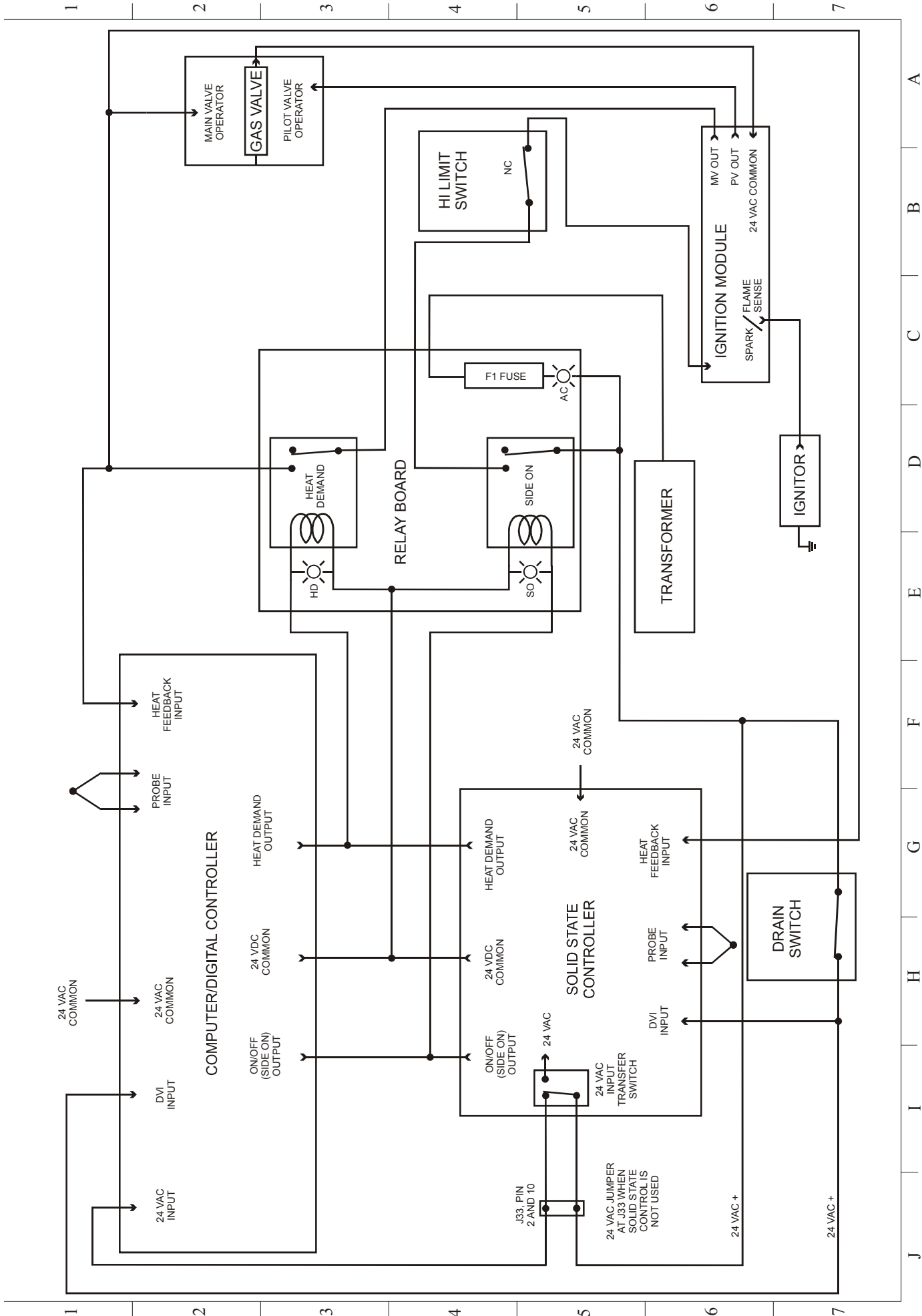

FRYER REPLACEMENT PARTS		CONTROLLER CONNECTIONS	
REF	DESCRIPTION	PIN#	DESCRIPTION
A5	SOLID STATE TEMP CNTRL, W/MELT&DVI (PRIM)	1	24VACH POWER IN
A1 (OPT)	DIGITAL TEMPERATURE CNTRL SINGLE	2	24VAC COM POWER RETURN (CONNECTED TO FRAME GND)
A1 (OPT)	DIGITAL TEMPERATURE CNTRL DUAL	3	PROBE +
A1 (OPT)	COMPUTER COOKING CNTRL SINGLE	4	PROBE -
A1 (OPT)	COMPUTER COOKING CNTRL DUAL	5	24VAC INPUT --DRAIN VALVE INTERLOCK (DVI)
A2 (DOMESTIC)	IGNITION MODULE	6	24VAC INPUT --HEAT FEED BACK
A2 (CE EXPORT)	IGNITION MODULE	7	24VDC POWER RETURN
A3 (OPT)	BACKUP SSTC, W/MELT & DVI	8	24VDC OUTPUT-- HEAT DEMAND
HL1	SWITCH, HIGH LIMIT	9	24VDC OUTPUT-- SIDE ON
T1	XFMR, 120--208--240/24VAC 80VA CLASS 2	10	24VDC OUTPUT-- BASKET LIFT RH
RT1,2	PROBE, NTC THERMISTOR GAS	11	24VDC OUTPUT-- BASKET LIFT LH
LS1 (TYPICAL)	SWITCH PROXIMITY MAGNETIC	12	24VACH TO PRIMARY CONTROLLER
	SWITCH ACTUATOR MAGNETIC		NOTE 2
E2	EI PILOT & HOOD ASSEMBLY NATURAL		
	EI PILOT & HOOD ASSEMBLY PROPANE		
F1	FUSE 1.5A 250V TIME DELAY CERAMIC		
V1 (DOMESTIC)	VALVE, GAS FAST OPEN 24VAC NATURAL		
	VALVE, GAS FAST OPEN 24VAC PROPANE		
V1 (CE EXPORT)	VALVE, GAS FAST OPEN 24VAC NATURAL		
	VALVE, GAS FAST OPEN 24VAC PROPANE		
A4	RELAY BOARD 24VAC CLASS 2		

REF	DESCRIPTION	LOCATION	PART NO.
A5	SOLID STATE TEMP CNTRL, W/MELT&DVI (PRIM)	SHEET 2, B3	B2004201-C
A1 (OPT)	DIGITAL TEMPERATURE CNTRL SINGLE	SHEET 2, J3	60126601
A1 (OPT)	DIGITAL TEMPERATURE CNTRL DUAL	SHEET 2, J3	60126701
A1 (OPT)	COMPUTER COOKING CNTRL SINGLE	SHEET 2, J3	60126801
A1 (OPT)	COMPUTER COOKING CNTRL DUAL	SHEET 2, J3	60126802
A2 (DOMESTIC)	IGNITION MODULE	SHEET 2, C6	60108601
A2 (CE EXPORT)	IGNITION MODULE	SHEET 2, C6	60132501
A3 (OPT)	BACKUP SSTC, W/MELT & DVI	SHEET 2, B3	B2004202-C
HL1	SWITCH, HIGH LIMIT	SHEET 2, E6	PP10084
T1	XFMR, 120--208--240/24VAC 80VA CLASS 2	SHEET 2, F2	PP10429
RT1,2	PROBE, NTC THERMISTOR GAS	SHEET 2, G7, C1	B6700604-C
LS1 (TYPICAL)	SWITCH PROXIMITY MAGNETIC	SHEET 2, I4	B5305001
	SWITCH ACTUATOR MAGNETIC	SHEET 2, I4	PP10263
E2	EI PILOT & HOOD ASSEMBLY NATURAL	SHEET 2, B6	60130901
	EI PILOT & HOOD ASSEMBLY PROPANE	SHEET 2, B6	60130902
F1	FUSE 1.5A 250V TIME DELAY CERAMIC	SHEET 2, E3	60132702
V1 (DOMESTIC)	VALVE, GAS FAST OPEN 24VAC NATURAL	SHEET 2, B6	60113501
	VALVE, GAS FAST OPEN 24VAC PROPANE	SHEET 2, B6	60113502
V1 (CE EXPORT)	VALVE, GAS FAST OPEN 24VAC NATURAL	SHEET 2, B6	60113503
	VALVE, GAS FAST OPEN 24VAC PROPANE	SHEET 2, B6	60113504
A4	RELAY BOARD 24VAC CLASS 2	SHEET 2, B6	60113505
		SHEET 2, G4	60127301

NOTES:

- STANDARD CONTROL (A5) MOUNTS BEHIND FRONT DOOR AND CONNECTS AT P3. BACKUP T-STAT AND BASKETLIFT OPTIONS NOT AVAILABLE WITH STANDARD CONTROL.
- WHERE OPTIONAL CONTROL (A1) IS SUPPLIED, 24VAC (J3--12) IS SWITCHED ON/OFF BY OPTIONAL BACKUP T-STAT (A5). INSTALL JUMPER BLOCK AT J33 IF NO BACKUP OPTION IS SUPPLIED.
- WIRING IS UL TYPE AWM, 300V, COLOR SHOWN. ALL WIRE IS 18AWG UNLESS NOTED.
- DRAIN VALVE SWITCH IS CLOSED WHEN VALVE IS CLOSED.
- LINE VOLTAGE CABLES ARE TYPE SJTO. WIRE GAUGE AS SHOWN (AWG).
- NO MORE THAN 4 CABINETS CONNECTED TOGETHER WITH JUMPER CORDS.

FILTER PUMP REPLACEMENT PARTS				
ITEM	VOLTAGE	DESCRIPTION	LOCATION	PART NO.
M1	120V-50/60Hz	MOTOR AND PUMP 1/3HP	SHEET 4, E4, J4	60130801
	230V-50/60Hz			
	240V/50Hz	MOTOR AND PUMP 1/3HP	SHEET 4, J6	60130802
CB1	120V-50/60Hz	CKT BRKR,10 AMP SINGLE POLE	SHEET 4, C3	60077901
	230V-50/60Hz	CKT BRKR, 5 AMP TWO POLE	SHEET 4, H3	60078502
	240V/50Hz			
T3	120V-50/60Hz	XFMR, 120/24VAC 5VA	SHEET 4, C3	60130301
	230V-50/60Hz	XFMR, 240/24 VAC 5VA	SHEET 4, G3	60130302
	240V-50Hz			
K5	120V-50/60Hz	RELAY, 24VAC, 30A SPST	SHEET 4, C4	PP11058
	230V-50/60Hz	RELAY, 24VAC, 30A DPST	SHEET 4, H4	60104701
	240V-50Hz			
F2	ALL	FUSE 0.2A 250V TIME DELAY CERAMIC	SHEET 4, G2	60132701
FH2		FUSE HOLDER, IN LINE, .25 X 1.25	SHEET 4, G2	PP10765

SHORTENING HEATER OPTIONS REPLACEMENT PARTS			
ITEM	VOLTAGE	DESCRIPTION	PART NO.
HTR1	120-50/60Hz	HEATER TAPE 1/2X 72", 50W	60133503
	230-50/60Hz	HEATER TAPE 1/2X 72", 50W	60133504
	240/50Hz		
HTR2,3	120-50/60Hz	HEATER TAPE 1/2X 33", 25W	60133501
	230-50/60Hz	HEATER TAPE 1/2X 33", 25W	60133502
	240/50Hz		

115V/60HZ

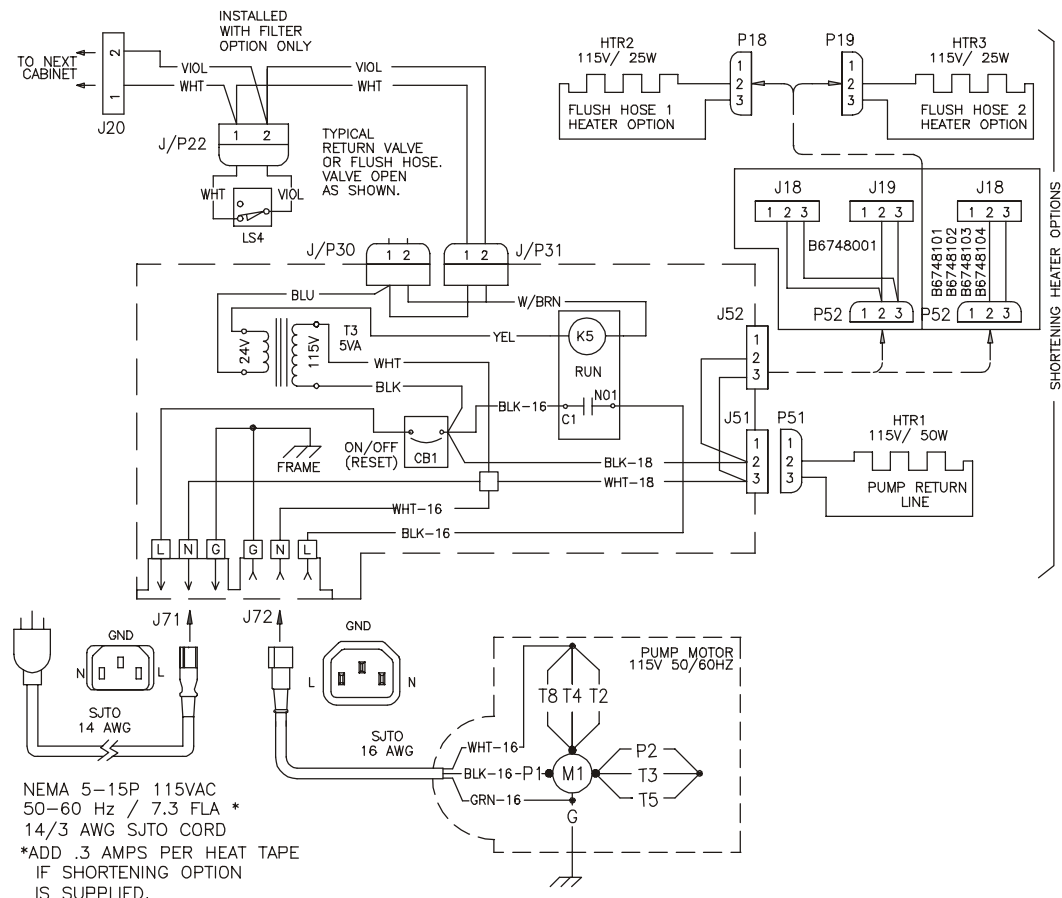

NEMA 5-15P 115VAC
 50-60 Hz / 7.3 FLA *
 14/3 AWG SJTO CORD
 *ADD .3 AMPS PER HEAT TAPE
 IF SHORTENING OPTION
 IS SUPPLIED.

220-230V OR 240V/50HZ

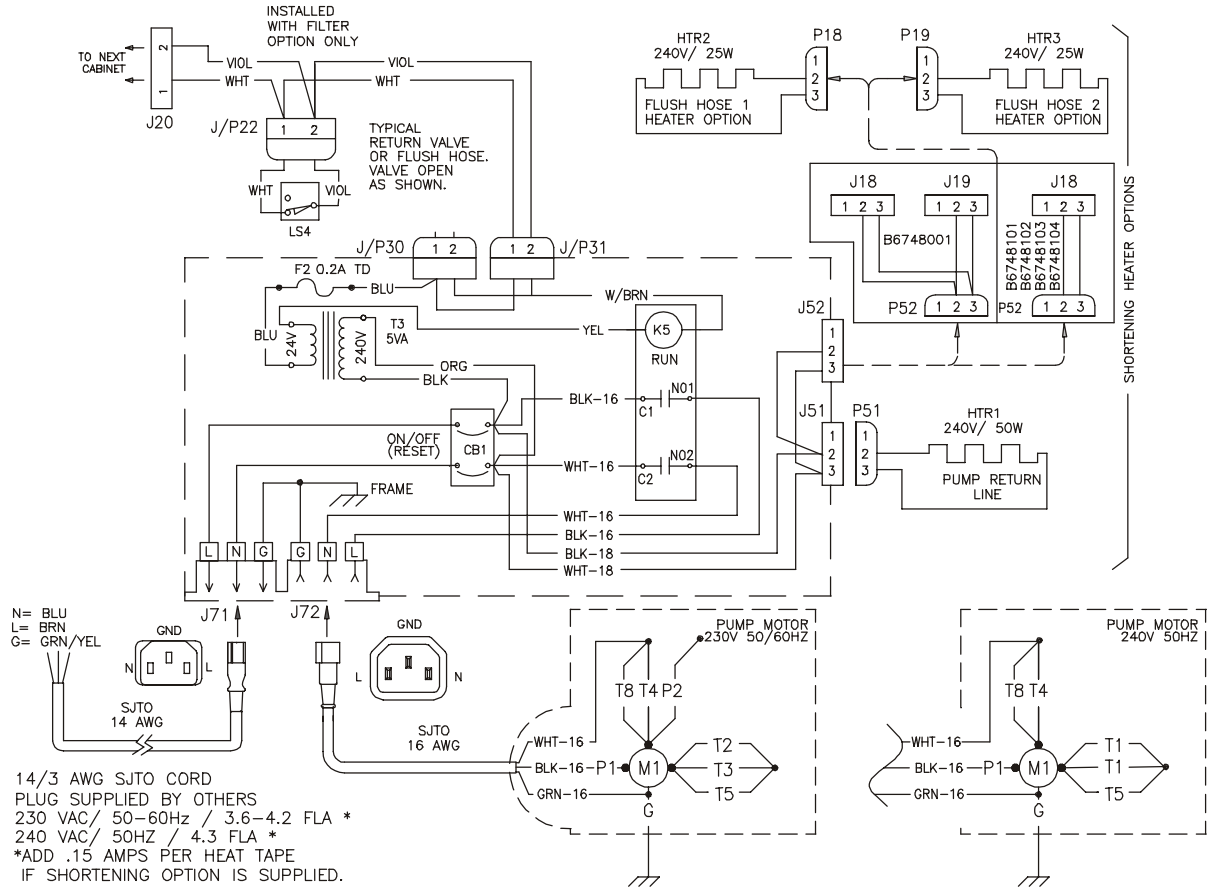

N= BLU
 L= BRN
 G= GRN/YEL

14/3 AWG SJTO CORD
 PLUG SUPPLIED BY OTHERS
 230 VAC/ 50-60Hz / 3.6-4.2 FLA *
 240 VAC/ 50HZ / 4.3 FLA *
 *ADD .15 AMPS PER HEAT TAPE
 IF SHORTENING OPTION IS SUPPLIED.

FRYER REPLACEMENT PARTS			
REF	DESCRIPTION	LOCATION	PART NO.
A5	SOLID STATE TEMP CNTRL, W/MELT&DVI (PRIM)	SHEET 2, B3	B2004201-C
A1 (OPT)	DIGITAL TEMPERATURE CNTRL SINGLE	SHEET 2, J3	60126601
A1 (OPT)	DIGITAL TEMPERATURE CNTRL DUAL	SHEET 2, J3	60126701
A1 (OPT)	COMPUTER COOKING CNTRL SINGLE	SHEET 2, J3	60126801
A1 (OPT)	COMPUTER COOKING CNTRL DUAL	SHEET 2, J3	60126802
A2 (DOMESTIC)	IGNITION MODULE	SHEET 2, C6	60108601
A2 (CE EXPORT)	IGNITION MODULE	SHEET 2, C6	60132501
A3 (OPT)	BACKUP SSTC, W/MELT & DVI	SHEET 2, B3	B2004202-C
HL1	SWITCH, HIGH LIMIT	SHEET 2, E6	PP10084
T1	XFMR, 120-208-240/24VAC 80VA CLASS 2	SHEET 2, F2	PP10429
RT1,2	PROBE, NTC THERMISTOR GAS	SHEET 2, G7, C1	B6700604-C
LS1 (TYPICAL)	SWITCH PROXIMITY MAGNETIC	SHEET 2, I4	B5305001
	SWITCH ACTUATOR MAGNETIC	SHEET 2, I4	PP10263
E2	EI PILOT & HOOD ASSEMBLY NATURAL	SHEET 2, B6	60130901
	EI PILOT & HOOD ASSEMBLY PROPANE	SHEET 2, B6	60130902
F1	FUSE 1.5A 250V TIME DELAY CERAMIC	SHEET 2, E3	60132702
V1 (DOMESTIC)	VALVE, GAS FAST OPEN 24VAC NATURAL	SHEET 2, B6	60113501
	VALVE, GAS FAST OPEN 24VAC PROPANE	SHEET 2, B6	60113502
V1 (CE EXPORT)	VALVE, GAS FAST OPEN 24VAC NATURAL	SHEET 2, B6	60113503
	VALVE, GAS FAST OPEN 24VAC PROPANE	SHEET 2, B6	60113504
	VALVE, GAS FAST OPEN 24VAC PROPANE UNREG	SHEET 2, B6	60113505
A4	RELAY BOARD 24VAC CLASS 2	SHEET 2, G4	60127301

CONTROLLER CONNECTIONS		
PIN#	DESCRIPTION	
1	24VACH POWER IN	
2	24VAC COM POWER RETURN (CONNECTED TO FRAME GND)	
3	PROBE +	
4	PROBE -	
5	24VAC INPUT -DRAIN VALVE INTERLOCK (DVI)	
6	24VAC INPUT -HEAT FEED BACK	
7	24VDC POWER RETURN	
8	24VDC OUTPUT- HEAT DEMAND	
9	24VDC OUTPUT- SIDE ON	
10	24VDC OUTPUT- BASKET LIFT RH	NOTE 1
11	24VDC OUTPUT- BASKET LIFT LH	
12	24VACH TO PRIMARY CONTROLLER	NOTE 2

TABLE 1				
PART NO.	DESCRIPTION	P/N REV	P/N ECN	NEXT ASSY
700324	SCHEM. GAS SINGLE OR DUAL SG	TITLE BLOCK		SEE MRP USAGE
700324-1	LBL, WIRING CNTRL TYPICAL 24V SG	A	9802	
700324-2	LBL, WIRING FLTR PUMP 115V/50-60HZ SG	A	9802	
700324-3	LBL, WIRING FLTR PUMP 230V/240V SG	A	9802	
700324-4	LBL, WIRING BASKET LIFT 115/208/240 SG	B	10833	

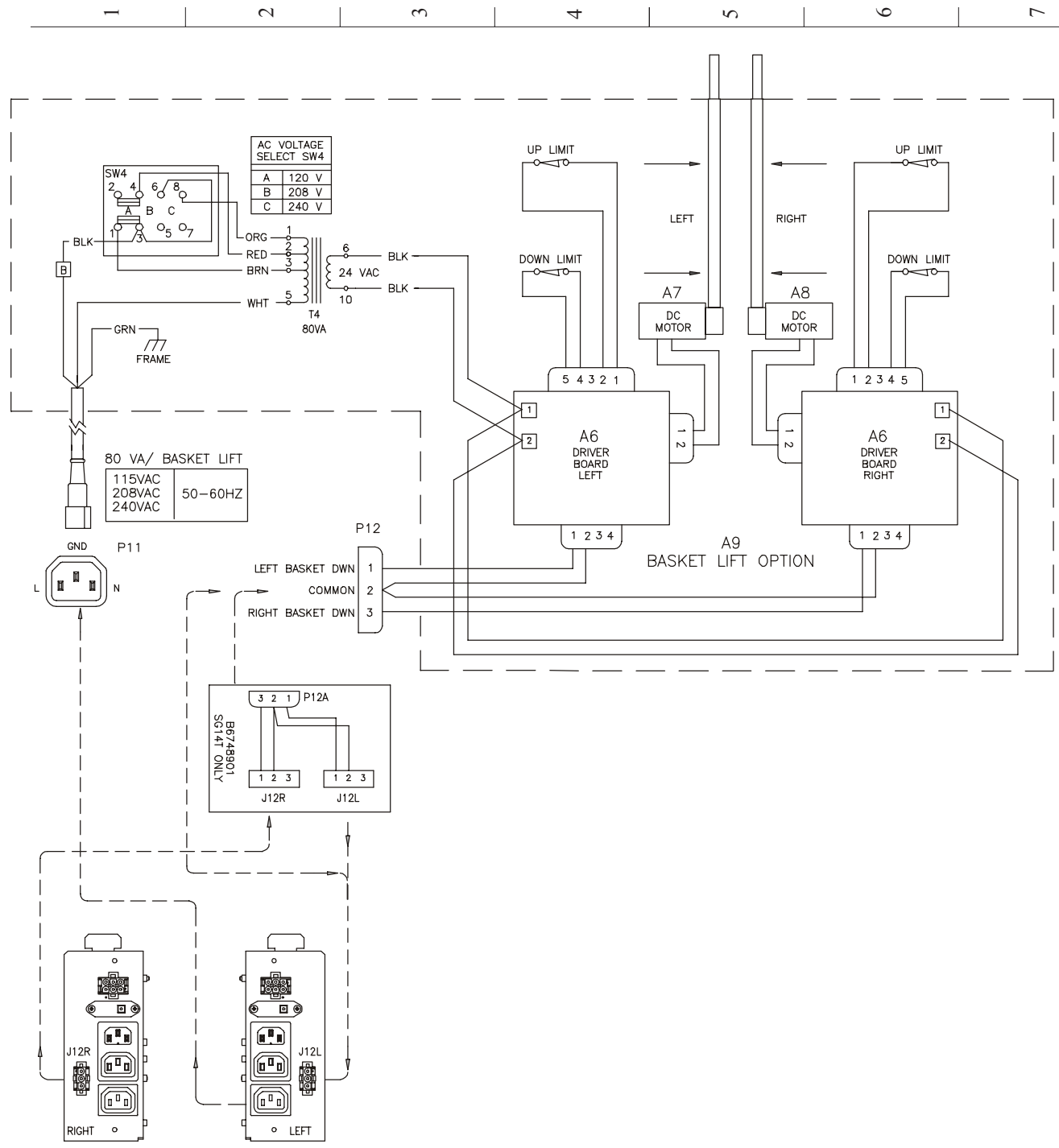

BASKET LIFT OPTION REPLACEMENT PARTS		
ITEM	DESCRIPTION	PART NO.
A9	COMPLETE BASKET LIFT ASSEMBY 120V	B5604601
	COMPLETE BASKET LIFT ASSEMBY 208V	B5604602
	COMPLETE BASKET LIFT ASSEMBY 240V	B5604603
A6	CNTL, BASKET LIFT DRIVER BRD 24V	60134001
A7	ACTUATOR, LINEAR DC MOTOR W/SWITCHES LH	60134301
A8	ACTUATOR, LINEAR DC MOTOR W/SWITCHES RH	60134302
T4	XFMR, 120-208-240/24VAC 80VA CLASS 2	PP10429

A
B
C
D
E
F
G
H
I
J

Exploded Drawings and Parts Lists

Parts Listing

Fryer Components:

Part Number Description

PP10084	Hi Limit Switch
PP10429	120/208/240V Transformer
B6700604-C	Temperature Probe
60132702	1.5A Time Delay Fuse
60127301	Relay Board
60132901	Relay Board Insulation
B2004201-C	Solid State Control
B2004202-C	Back-up SolidState Control
60126601	Digital Control
60126701	Dual Digital Control
60126801	Computer Control
60126802	Dual Computer Control
60108601	Ignition Module
60132501	CE Ignition Module
60113501	Nat Gas Valve
60113502	LP Gas Valve
60113503	CE Nat Gas Valve
60113504	CE LP Gas Valve
60113505	CE LP Unregulated Gas Valve
60125901	Gas Valve Vent Tube
60119001	Pilot Tubing
60130901	Nat Pilot Assembly
60130902	LP Pilot ssembly
B5305001	DVI/Return Switch
PP10263	DVI/ReturnActuator

Filter Components:

Part Number Description

60130806	115/220V Pump & Motor
60130807	240V Pump & Motor
60130810	208V Pump & Motor
60130803	115/220V Motor
60130804	240V Motor
60130809	208V Motor
PP10417	5 GPM Pump
60077901	10A Circuit Breaker (120V)
60078502	5A Circuit Breaker(208-240V)
60130301	120/24V Transformer
60130302	230-240/24V Transformer
60130303	208/24V Transformer
PP11058	24VAC SPST Relay (120V)
60104701	24VAC DPDT Relay (208-240V)
60132701	0.2A Time Delay Fuse
60133503	120V Heat Tape (Pump)
60133504	230/240V Heat Tape (Pump)

60133501	120V Heat Tape (Flush Hose)
60133502	230/240V Heat Tape (Flush Hose)
PP11104	1" Viton O-ring
60138701	Full/LH Non Locking Drain Valve
60138702	RH Non Locking Drain Valve
60138703	Full/LH Locking Drain Valve
60138704	RH Locking Drain Valve
60059302	Drain Line Gasket
60127702	Drain Line Clamp
B6665101	Drain Elbow
B6665201	Drain Tee Full
A7022407	Drain Line Tube Full/Full
A7022409	Drain Line Tube Split/Full
A7022411	Drain Line Tube Split/Split
A7022101	Drain Tee Ferrule
A7022201	Drain Tee Flange
B6664701	Drain Down Spout Full/Full
B6673301	Drain Down Spout Split
B5305001	DVI/Return Switch
PP10263	DVI/ReturnActuator
B6671201	Strainer Cap
B4004501	Full Return Handle
B4004601	Left Split Return Handle
B4004701	Right Split Return Handle
60131801	Return Valve
A7008302	Paper Support
B6673801	Filter Pan

Miscellaneous

Part Number Description

P6073148	Full Vat Tube Rack
B4511801	Split Vat Tube Rack
A1103204	Basket Hanger
60138101	Basket Hanger Stud
A4107802	Splash Back
60059701	Nylon Cleaning Brush
A3301001	Cleanout Rod
B2304602	LH/RH Door
B3801901	RH Hinge Kit
B3801902	LH Hinge Kit
B3902101	9" Caster Set (4)
A1908202	Channel Strip
B2101503	Full/Twin Tank Cover

Table 1
Element and Tank Components

Item#	Part#	Part Description
1.....	A1103204	Basket Hanger
2.....	A4107802	Splash Back
3.....	60138101	Basket Hanger Stud
	60118201	Bolt,Hex 1/4-20 X 3/4
4.....	PP10084.....	Hi Limit Switch
5.....	PP11366	Screw, 10-24 X 5/8 PHH SS TF
6.....	A1406802	Probe/Hi Limit Bracket
7.....	B6700604-C	Temperature Probe
8.....	Contact Factory	Top Deck
9.....	A3671102	Left/Right Front Panel End Cap
	A3671002	Front Panel Middle Cap
10.....	60127301	Relay Board
	60132702	Relay Board Fuse, 1.5A Time Delay
11.....	60126601	Solid State Digital Controller
	60126701	Dual Solid State Digital Controller
	60126801	Computer Controller
	60126802	Dual Computer Controller
12.....	B3631303	Bezel
	B3631805	Blank Bezel
13.....	B2004201-C	Primary Solid State Controller
	B2004202-C	Back-up Solid State Controller
14.....	PP10916.....	Probe Fitting
15.....	60132901	Relay Board Insulation
16.....	A3667906	Front Panel Bottom Rail
17.....	B3324501-C	Full Vat Tank
	B3324601-C	Split Vat Tank

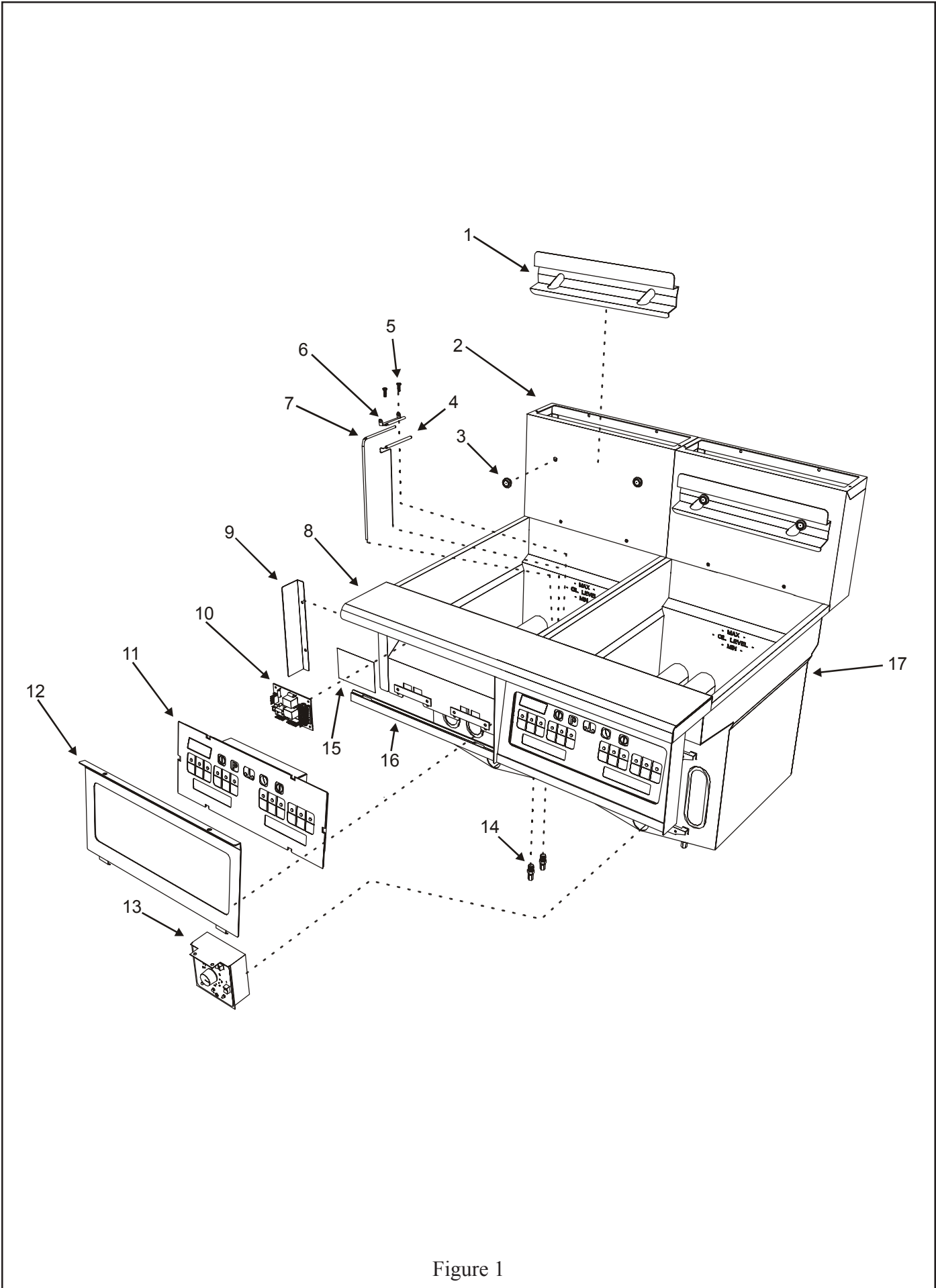
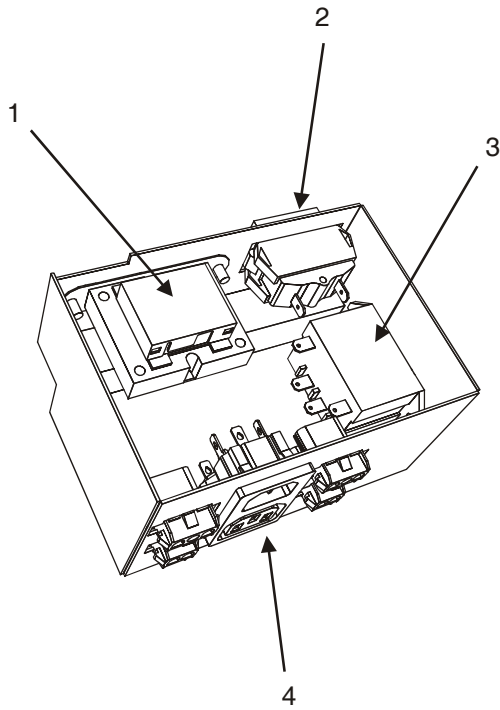

Figure 1

Table 2 Check & replace if defective

Pump Box and Drain Manifold

Item#	Part#	Part Description
1	60130301	120/24V Transformer
	60130302	230-240/24VAC Transformer
	60130303	208VAC Transformer
2	60077901	10A Circuit Breaker (120V)
	60078502	5A Circuit Breaker (208V-240V)
3	PP11058	24VAC SPST Relay (120V)
	60104701	24VAC DPDT Relay (208-240V)
4	60130701	Conn, Pwr In & Out IEC320
5	60138701	Drain Valve, Full/Right Split, W/Non-locking Handle
	60138703	Drain Valve, Full/Right Split, W/Locking Handle
6	A7021701	Drain Valve Nipple
7	A7022201	Drain Flange
8	A7022101	Drain Ferrule
9	B6665101	Drain Elbow
10	60088002	Hex Bolt 3/8"x16x1-1/4"
11	P0082700	Lock Washer 3/8"
12	60127701	Drain Line Clamp
13	60059302	Drain Line Gasket
14	B6664701	Drain Down Spout Full/Full
	B6673301	Drain Down Spout Split
15	60138702	Drain Valve, Left Split, W/Non-locking Handle
	60138704	Drain Valve, Left Split, W/Locking Handle
16	Contact Factory	Drain Line Tube
17	PP10263	DVI Actuator
18	B5305001	DVI Switch Assembly
19	PP10266	Screw, 4-40 X .250 RDH ZN



Pump Entrance Box
(viewed from bottom)

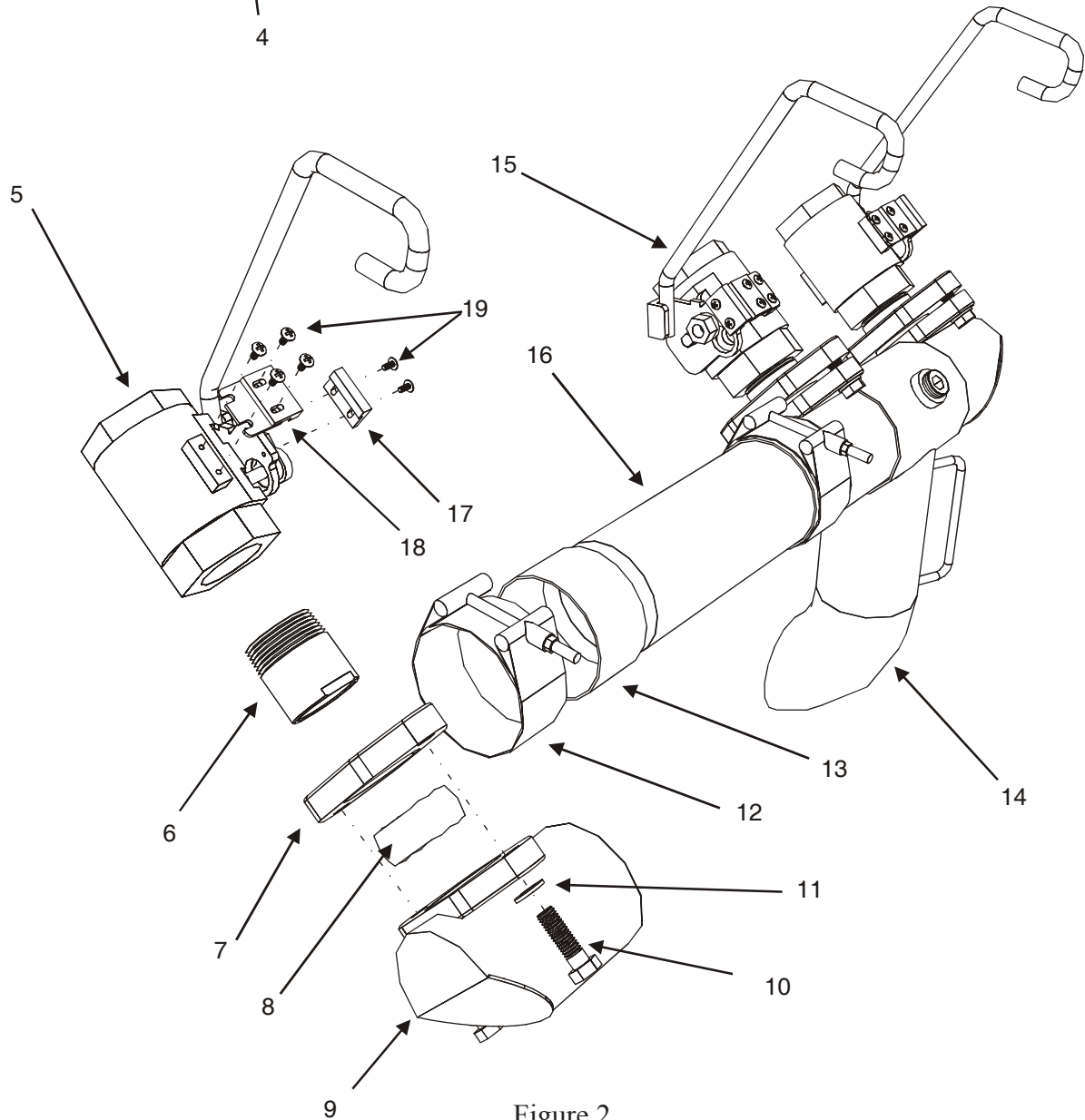

Figure 2

Table 3
Main Entrance Box

Item#	Part#	Part Description
1	60130701	IEC In & Out Connector
2	PP10689	Screw, 6-32 X 1/2
3	A2958102	Switch Cover 120V
	A2958104	Switch Cover 208V
	A2958106	Switch Cover 220V/240V
4	B6744901	Voltage Selector Switch
5	PP10429	Multi Tap 24VAC Transformer
6	PP10686	Screw, 6-32 X 1/4
7	B6744601	Harness, RH Module
	B6744602	Harness, LH Module
	B6744603	Harness, RH CE Module
	B6744604	Harness, LH CE Module
8	60108601	Ignition Module
	60132501	CE Ignition Module
9	PP10690	Screw, 6-32 X 1/2
10	A2957901	Ignition Module Mounting Bracket
11	B6751101	Harness, Spinal Tap
12	B8037303	Nat SGH Burner
	B8030001	LP SGH Burner
13	A8031701	Nat SGH Burner Shroud
	A8031703	LP SGH Burner Shroud
	A8031801	Nat SGH Twin Burner Shroud
14	A8031601	Flame Jumper
15	See Table	Burner Orifice Tip
16	60127501	Fitting
17	60127601	Swivel Fitting
18	60113501	Nat Gas Valve
	60113502	LP Gas Valve
	60135503	CE Nat Gas Valve
	60135504	CE LP Gas Valve
	60135505	CE LP Unregulated Gas Valve
19	60125901	Gas Valve Vent Tube
20	A8032101	Full Vat Gas Valve Sheild
	A8032201	Split/Twin Vat Gas Valve Sheild
21	60130901	Nat Pilot Assembly
	60130902	LP Pilot Assembly
22	A8029602	Pilot Bracket
23	A8029101	Gas Supply Coupling
24	60128001	Gas Flex Tube With Fittings
25	60128101	Gas Supply Shut Off
26	60127401	Flare/Npt Elbow

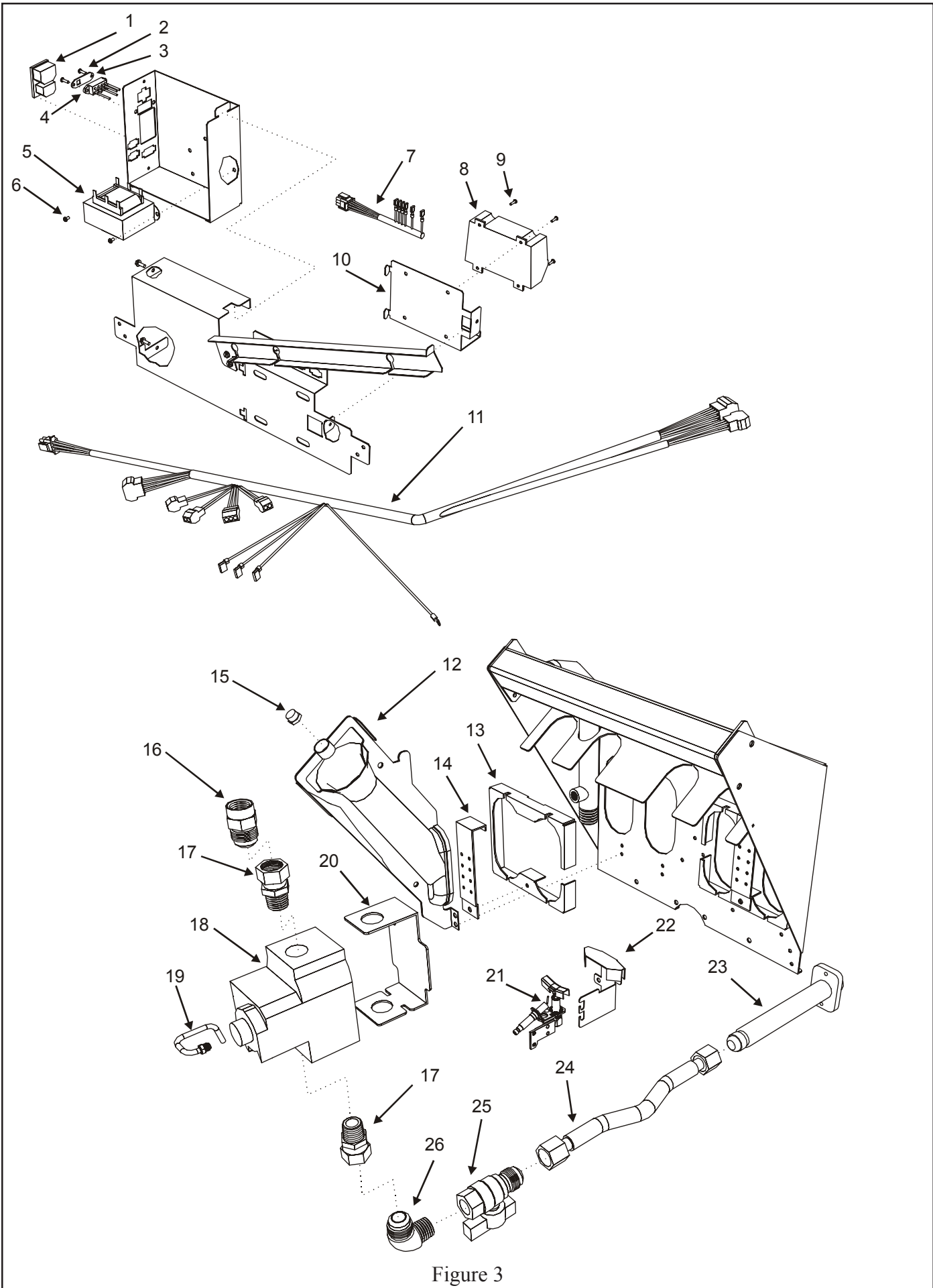

Figure 3

Table 4
Pump Assembly and Filter Pan

Item#	Part#	Part Description
1	B4004501	Full Return Handle
	B4004601	Left Split Return Handle
	B4004701	Right Split Return Handle
2	P0190200	Cotter Pin 1/16"x3/4"
3	60131901	Washer, Spring 5/8" with 5/16" Hole
4	P0080750	Washer, Flat 5/16"
5	P0075400	Screw, 10-24 X 1/2
6	A7020501	Return Handle Bracket Cover
7	A7028001	Return Handle Bracket
8	B5305001	DVI Return Switch
9	PP10266	4-40 x 1/4" Screw
10	PP10266	4-40 x 1/4" Screw
11	PP10263	DVI Return Actuator
12	P7037751	3/4" Street Elbow
13	60136801	3/4" X 1/2" Street Elbow
14	60130806	115/220VAC Pump & Motor Assembly
	60130807	240VAC Pump & Motor Assembly
	60130810	208VAC Pump & Motor Assembly
	60130804	115/220V Motor Only
	60130804	240VAC Motor Only
	60130809	208VAC Motor Only
	PP10417	5 GPM Pump Only
15	P6071516	3/4" x 4" NPT Nipple
16	A7027602	Pickup Tube Receiving Block
17	PP11104	1" x 1.18" viton O-ring (3 required)
18	A7008302	Paper Support
19	B6671201	Pickup Tube Strainer
20	60131401	Rigid Caster
21	B6673401	Filter Pan Only (no casters)
22	B6673501	Paper Hold Down
23	P7036603	3/4" NPT Coupling
24	60131301	3/4" X 9" Nipple
25	PP10485	3/4" X 1/2" Elbow
26	P7037092	1/2" X 1-1/2" Nipple
27	60132201	Hose, fluoropolymer swivel FxMPT
28	A8033801	Flare Fitting Elbow
29	60128008	Tbg, Flex Return Line 0.5" x 15.5"
	60128009	Tbg, Flex Return Line 0.5" x 19"
	60128010	Tbg, Flex Return Line 0.5" x 22"
	60128011	Tbg, Flex Return Line 0.5" x 10"
30	60131801	Return Valve
31	60130001	End Cap
32	60130101	Tank Return Fitting
<u>Additional Parts Not Shown</u>		
	PP11323	Filter Paper
	60133503	120V Heat Tape (pump)
	60133504	230/240V Heat Tape (pump)
	60133501	120V Heat Tape (flush hose)
	60133502	230/240V Heat Tape (flush hose)

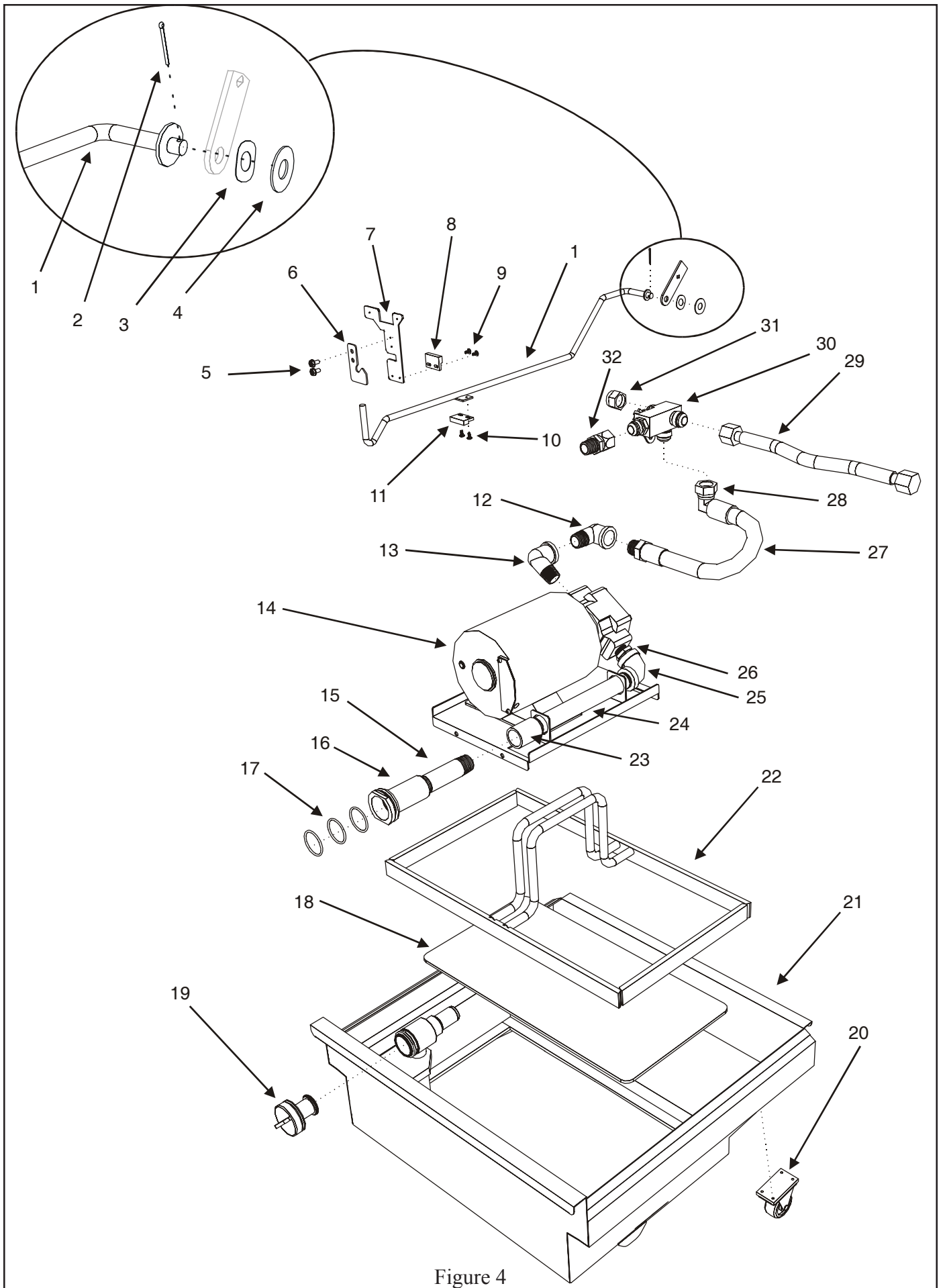
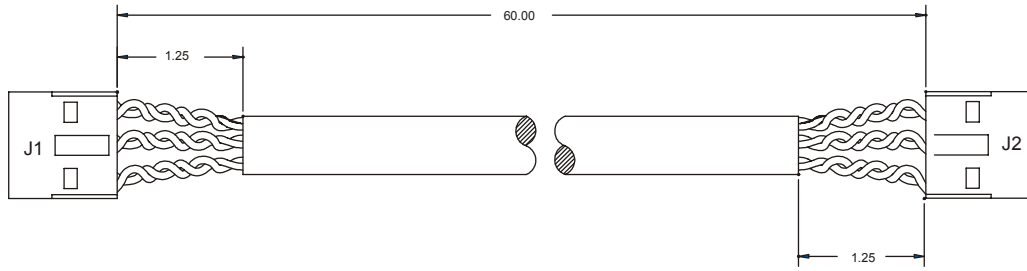
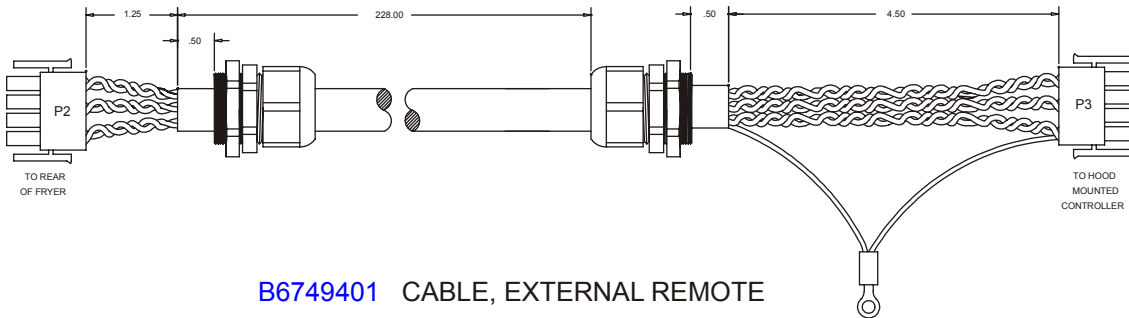

Figure 4



J		SCHEMATIC		J	
10					10
11					11
1		BK	1		
2		GR	2		
3		BK	3		
4		W	4		
5		BK	5		
6		R	6		
7		BK	7		
8		BL	8		
9		BK	9		
12		Y	12		

B6749301 CABLE, INTERNAL REMOTE



P2		SCHEMATIC		P3	
10					10
11					11
1		BK	1		
2		GR	2		
3		BK	3		
4		W	4		
5		BK	5		
6		R	6		
7		BK	7		
8		BL	8		
9		BK	9		
12		Y	12		

B6749401 CABLE, EXTERNAL REMOTE

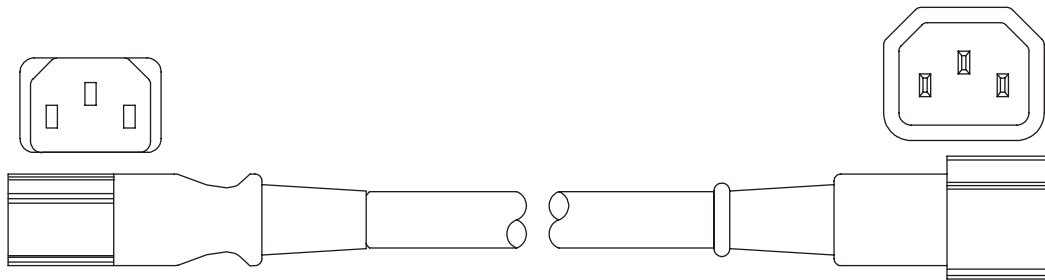

60128403 CORD,M-F JUMPER IEC-320X34"

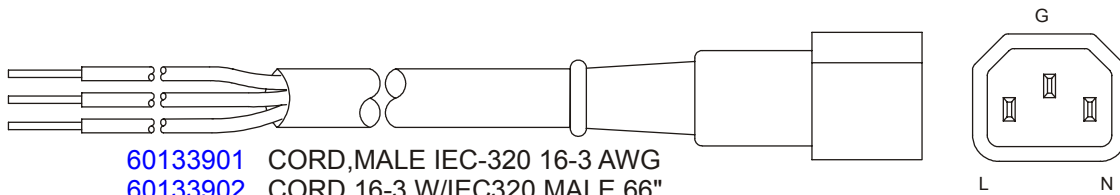

60133901 CORD,MALE IEC-320 16-3 AWG
60133902 CORD,16-3 W/IEC320 MALE 66"

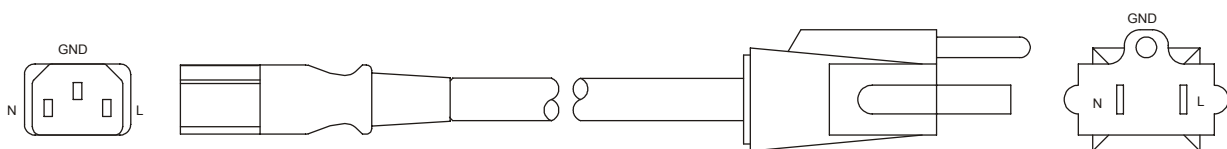

60128501 CORD, FEMALE IEC/NEMA 5-15

Figure 6



In the event of problems with or questions about your order, please contact the Pitco Frialator factory, from 8:00 a.m. - 5:00 p.m., Eastern Standard Time, Monday through Friday, 1-603-225-6684

In the event of problems with or questions about your order, please contact the Pitco Frialator Authorized Service and Parts representative (ASAP) covering your area, through Pitco at:

1-603-225-6684