

PIPER

The Food-Focused Equipment Company

ROLL-IN PROOFER

RIP-1, RIP-2

Installation and Operating Manual



For service information call 800-544-3057

Please have the following information available before calling. Information can be found on the identification/certification tag:

- Model Number
- Serial Number
- Date of Purchase
- Part Description and number as shown in parts list



**IMPORTANT INFORMATION
READ BEFORE USE**

This manual contains important safety information concerning the maintenance, use and operation of this product. Failure to follow these instructions could result in damaging equipment, voiding the warranty, serious injury or even death.

Piper Products, Inc
300 South 84th Avenue
Wausau, WI 54401

Phone: 715-842-2724 . FAX: 715-842-3125

TABLE OF CONTENTS

2	INTRODUCTION
2	FREIGHT DAMAGE CLAIMS
3	SAFETY PRECAUTIONS
3	UNPACKING YOUR EQUIPMENT
4	INSTALLATION
5	PLUMBING INFORMATION
6	OPERATING INSTRUCTIONS
7	GENERAL CLEANING
8	MAINTENANCE
9	TROUBLESHOOTING GUIDE
10	REPLACEMENT PARTS - FRONT
11	REPLACEMENT PARTS - SIDE
12	REPLACEMENT PARTS - REAR
13	REPLACEMENT PARTS - FAN ASSEMBLY
14	REPLACEMENT PARTS - RIP-1 AUTO HUMIDITY
15	REPLACEMENT PARTS - RIP-1 AUTO HUMIDITY
16	WIRING DIAGRAM - RIP-1 WITH AUTOFILL
17	WIRING DIAGRAM - RIP-2 WITH AUTOFILL
18	WARRANTY

INTRODUCTION

Congratulations! You have just purchased one of the finest pieces of equipment on the market today. Before installing or operating your new Piper equipment, you should read through this manual. This manual should be retained for further reference as it contains installation and operating instructions, service tips, part lists and warranty information.

For your safety, read and follow all cautions and warnings.

FREIGHT DAMAGE CLAIMS

Your Piper equipment was carefully inspected and packed before leaving our factory. The transportation company assumes full responsibility for safe delivery of this equipment. Piper Products cannot assume responsibilities for damage or loss incurred in transit. Visible damage or loss should be noted on the freight bill and signed by the person making the delivery.

A freight claim should be filed immediately with the transportation company. If damage is unnoticed or concealed until equipment is unpacked, notify the transportation company immediately and tell them you want to file a concealed damage claim. This must be done within five (5) days after delivery was made. Be sure to retain all packing material and cartons.

WARNING

Installation of this equipment should be done only by persons qualified or licensed to install electrical equipment. All electrical and plumbing must meet local, state, and federal codes.

Plumbing installation must be performed by a qualified plumber.

Adjustments and service work should be performed only by a qualified service technician. Service is available through Authorized Piper Parts and Service Distributors throughout the United States. For a complete listing of these call or write Piper Products, Inc. for the name of the nearest distributor.

This equipment is intended for commercial use only. Not for household use. Use of other than genuine Piper replacement parts or service work performed by other than an authorized Piper service agent will void the warranty.

Do not use any corrosive cleaners. Piper only approves soap and water for cleaning stainless steel.

SAFETY PRECAUTIONS

1. Read all instructions and warranty before operating unit.
2. Equipment should be installed by a qualified electrician familiar with local electrical codes.
3. Equipment should be installed on a solid, level floor.
4. Adequate space should be allocated surrounding the unit to allow for proper airflow and provide access for servicing (see electrical information for more details).
5. Flammable materials should not be stored near the equipment. Do not cover or block any openings or vents.
6. Surfaces on equipment may become extremely hot. Exercise caution when operating.
7. All warnings and operating instructions should be followed.
8. When replacement parts are required, be sure the service technician has parts specified by the manufacturer or have the same characteristics as the original part. Unauthorized substitutions may result in fire, electrical shock or other hazards.
9. This Operators Manual should be retained for future reference.

UNPACKING YOUR EQUIPMENT

1. Check crate for damage upon arrival. Make notation on freight of any damage.
2. Uncrate equipment and check for concealed damage. If damaged, call freight company immediately to come and inspect the equipment. Save the crate and packing material for inspection.

TO REMOVE THE EQUIPMENT FROM THE SKID

1. Tilt unit backward at a 45° angle.
2. Push down on front of skid breaking off narrow board on back.
3. Remove skid by pulling forward.

YOUR SHIPMENT SHOULD CONSIST OF:

**RIP-1
or
RIP-2**

INSTALLATION



ELECTRICAL CONNECTION

WARNING!!!! DO NOT USE EXTENSION CORDS (VOIDS WARRANTY)

Ground:

The electrical outlet must be provided with an efficient ground, and the voltage and the frequency of the electrical line matches those indicated on the data plate.



If unsure about the efficiency of the ground, have your electrical circuit checked by a qualified technician.

- Carefully remove carton or crate from unit. Remove all loose packing materials, making sure that no small parts or accessories are lost. Inspect the unit for concealed damage before discarding packing materials.
- It is the responsibility of the installer to comply with all local codes.
- Electrical installation should be made by a licensed electrician.
- Check unit nameplate for electrical requirements. Make sure that the thermostats are all set to the “OFF” position. Connect the electrical power cord and plug to a properly sized power source of the correct voltage.
- Supplied voltage must correspond with the voltage specified on the serial plate.



WARNING!: Improper voltage supplied to the unit will void the warranty. Voltage variation can cause erratic operation and serious damage to the electrical system.

- All external wiring should conform to the national, state and local electrical code requirements. See electrical specifications listed in the back of this manual for more details on your Holding Cabinet.
- Equipment must be properly grounded to prevent electrical shock.
- Equipment must have a separate ground.
- For more details see electrical specifications listed on the wiring diagram in the back of this manual.



WARNING!: Allow 4” from wall on the rear of the unit for airflow.

PLUMBING INFORMATION

A 1/4" FPT (female pipe thread) connector is provided on all units that require a water hookup. Units with automatic humidity and/or automatic steam injection have plumbing connections located on the right rear corner post approximately 8" up from the floor.



WARNING! Improper voltage supplied to the unit will void the warranty. Voltage variation can cause erratic operation and serious damage to the electrical system.

NOTE: Piper's automatic steam and humidity systems **MUST** be connected to a source of clean and filtered water. The filter removes solid particles and dissolves minerals (such as what is commonly found in hard water) to prevent scale build-up on the water heating element.

IMPORTANT!

YOUR LOCAL WATER CONDITIONS MAY PERMANENTLY DAMAGE THIS APPLIANCE. FAILURE TO PROPERLY TREAT WATER MAY RESULT IN DAMAGE AND WILL VOID YOUR WARRANTY. ENSURE THAT YOUR WATER SUPPLY MEETS THESE MINIMUM WATER QUALITY SPECIFICATIONS BELOW BEFORE INSTALLING.

FAILURE TO MEET THESE REQUIREMENTS, AND PROVIDE PROOF OF WATER QUALITY, **WILL VOID MANUFACTURERS WARRANTY.**

Parameter	Unit	Value
Alkalinity	ppm	30
Aluminum	ppb	15
Total Hardness	ppm	7
Calcium	ppm	6

Parameter	Unit	Value
Magnesium	ppm	1
Free Chlorine Residual	ppm	0.5
PH	s.u	8
Sodium	ppm	7

OPERATING INSTRUCTIONS

- Turn the power switch “ON”.
- Set the thermostat to 100°F. Allow approximately 15-30 minutes to reach temperature
- Set the humidity control to 3 to 4.5. At the proper setting your proofer door will have a light haze on it. This process will take approximately 15-30 minutes. If water beads up and runs down the door, the setting is too high. You may need to adjust according to atmospheric conditions.*
- Drain humidity system **DAILY**. Drain valve is located on lower front corner post.

Ideal proofing conditions consist of a temperature of 100°F and approximately 60-80% humidity. Proofing times will vary depending on the handling and the type of dough products. Sugar and yeast must be able to react properly which takes a certain amount of time. This cannot be altered by adjusting the settings. Correct proofing is very important for a successful bake.

Make sure dough is completely thawed and at room temperature (if using frozen dough products) before placing the products in the proofer. If not, it can take two to three times longer to proof.



HINT: You may want to place the dough (from the retarder) on a room temperature pan – not the cold pan it was just sitting on. This helps shorten the proofing time. When putting cold pans in the proofer, you bring the temperature down, taking longer for it to get back to the desired 100 degree temperature.

GENERAL CLEANING



CAUTION: BURN HAZARD: Some exterior surfaces on unit will get hot. Use caution when touching these areas.

DO NOT clean the unit while it contains any food product. Remove food product and allow unit to cool completely before cleaning or servicing.

CAUTION: Prior to cleaning or maintenance, turn all switches “OFF” and disconnect the power.

Stainless Steel and Aluminum:

- Piper only approves soap and water for cleaning stainless steel.
- **NOTICE:** Do NOT use chlorinated cleaners.

Hardened Foods or Scale Deposits:

- Clean hardened foods or scale deposits by utilizing a plastic scouring pad and a mild detergent. Rinse completely with warm water and dry.
- **NOTICE:** Do NOT use steel wool

MAINTENANCE

To obtain the best performance from your equipment, it should be cleaned daily and maintained in good condition.



SAFETY / ENVIRONMENTAL CAUTION

PERSONAL PROTECTION:

Check your company safety and environmental policy before cleaning or servicing.



Safety Tip! : Utilize protective gloves and safety glasses

ELECTRICAL POWER:



Before performing EXTENDED CLEANING where electrical components can become wet, the power switch must be turned to OFF and the unit disconnected from the power source.



WARNING: Do not use any chlorinated or highly caustic cleaners, acids, ammonia or other corrosive cleaners. These may cause corrosion and/or damage to the stainless steel. Piper only approves soap and water for cleaning stainless steel.

REQUIRED MONTHLY MAINTENANCE:

- Check thermostat settings
- Check operating temperature of unit
- Check electrical connection

TROUBLESHOOTING GUIDE

If problems are not found by the following checks, then you should contact your Authorized Parts and Service Dealer for service. They have the necessary parts and training to repair your unit quickly and efficiently.



DANGER: Disconnect all power to unit before servicing.

SYMPTOMS	REMEDIES
Insufficient heat in the holding cabinet	Check circuit breaker.
	Check if blower is operating.
	Check for faulty thermostat. Indicator light should come "ON" when thermostat is turned up.
	Check to see if door fits properly.
Excessive heat in holding cabinet	Check for faulty thermostat. Indicator light stays "ON" at all times.
	Check to see if humidity burner cycles off with the indicator light.
Insufficient humidity in the holding cabinet	Check fuse.
	Check relay for water solenoid valve.
	Check water supply to proofer.
	Check for faulty solenoid valve.
	Check for stuck water float.
	Check relay for steam generator heating element
	Check for faulty heating element.
Excessive humidity in the holding cabinet.	Check for water level being too high.
	Check float for being stuck in the down position.
	Check water solenoid valve for sticking open.

NOTE: Piper's automatic steam and humidity systems **MUST** be connected to a source of clean and filtered water. The filter removes solid particles and dissolves minerals (such as what is commonly found in hard water) to prevent scale build-up on the water heating element.

Call Piper Products directly at 800-544-3057 if you need further assistance.

REPLACEMENT PARTS FRONT

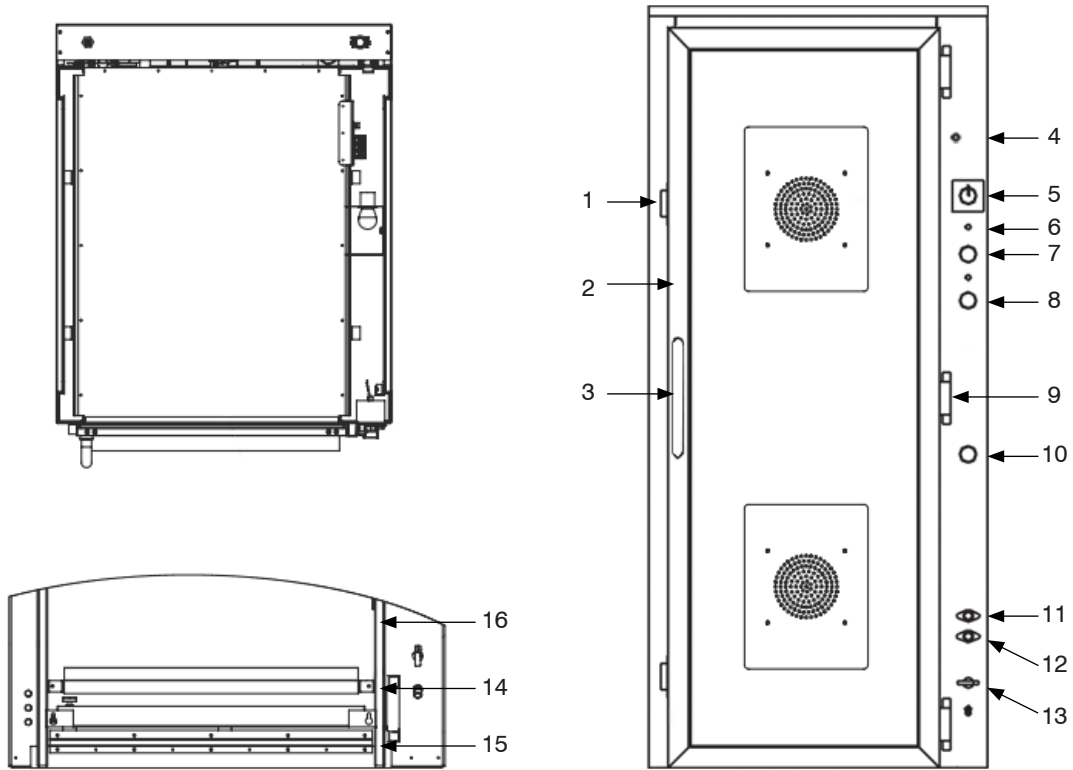

ITEM NO.	PART NUMBER	DESCRIPTION
1	305612	MAGNET, S/S ENCASED
2	11-0000067-000	DOOR ASSEMBLY, PROOFER
3	305002	HANDLE, DOOR
4	305613	BUMPER, DOOR STOP
5	705484	SWITCH DISCONNECT, 3-POLE 30 AMP
6	705160	INDICATOR LIGHT, 250V
7	705705	THERMOSTAT, PROOFER 60-125 DEG KIT
8	705757	SWITCH, INFINITE 120V HUMIDITY CONTROL KIT
9	305012	HINGE
10	706155	TIMER, 60 MINUTE
11	705518	FUSE HOLDER, 15 AMP
(w/ HUMIDITY)	13-700171	FUSE HOLDER - 20 AMP
12	705514	FUSE, 15 AMP
(w/ HUMIDITY)	705514	FUSE, 20 AMP
13	701930	BALL VALVE, STEAM/HUMIDITY
	701931	KNOB, BALL VALVE
14	11-0000066-000	DRIP TROUGH ASSEMBLY
15	105052	DOOR SWEEP ASSEMBLY
16	305206	DOOR GASKET - 15'

REPLACEMENT PARTS SIDE

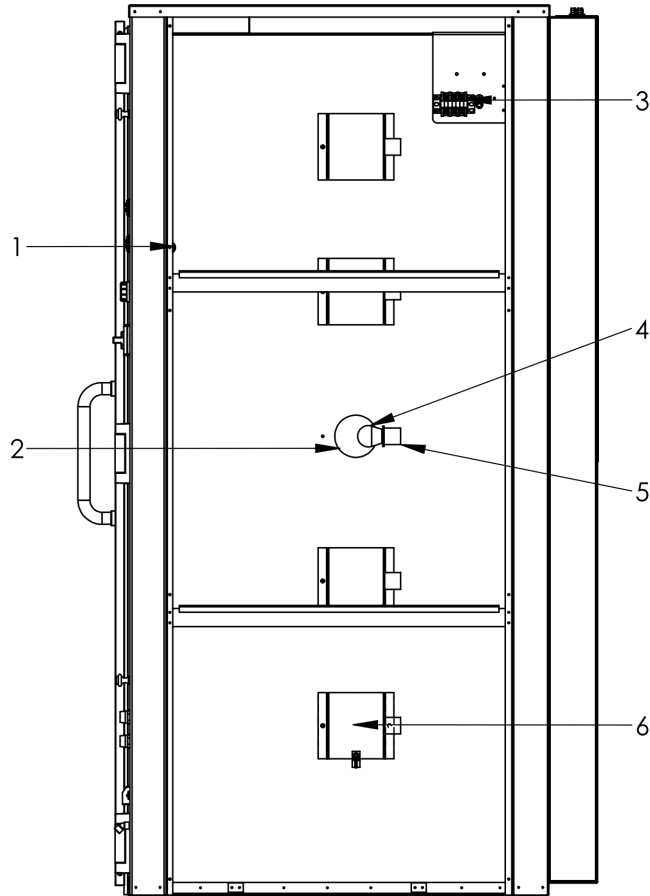

ITEM NO.	PART NUMBER	DESCRIPTION
1	705532	BUZZER
2	305209	GASKET, LIGHT COVER
2	200001	GLASS, LIGHT COVER 4.5" x 4.5"
3	705366	TERMINAL BLOCK, 75A 3 POLE
4	705146	LIGHT BULB, 40W, 130V
5	705157	ROUND LIGHT SOCKET
6	104075	LIGHT SOCKET HOLDER

REPLACEMENT PARTS REAR

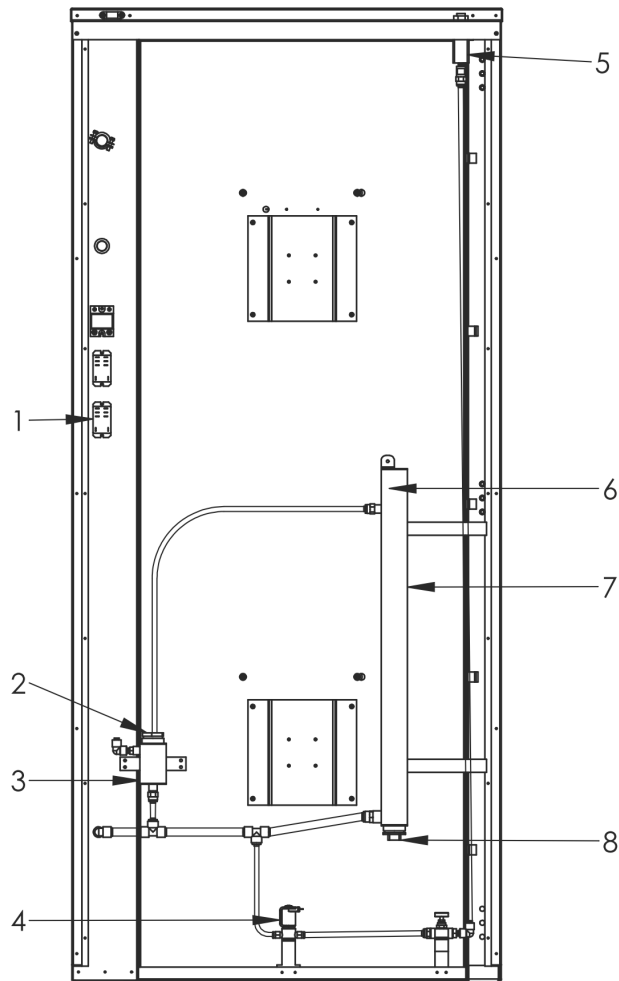

ITEM NO.	PART NUMBER	DESCRIPTION
1	705426	RELAY, HUMIDITY, 120V
2	705476	SWITCH, FLOAT HUMIDITY LIQUID LEVEL
3	105077	FLOAT CHAMBER, HUMIDITY
4	705864	SOLENOID VALVE, HUMIDITY, 120V
5	701960	AQUA-FLOW, STEAM / HUMIDITY
6	701508	HUMIDITY NOZZLE
7	11-0000511-000	CHAMBER, PROOFER HUMIDITY
8	704300	ELEMENT, IMMERSION - HUMIDITY 120V, 1500W
	305213	GASKET FOR HUMIDITY ELEMENT

REPLACEMENT PARTS FAN ASSEMBLY

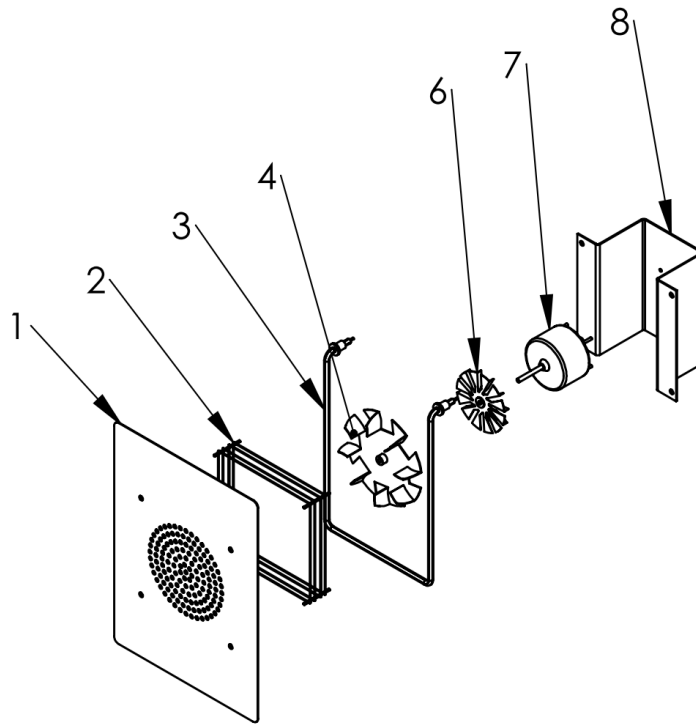

ITEM NO.	PART NUMBER	DESCRIPTION
1	102059	FAN COVER, PROOFER
2	705821	GUARD, FAN BLADE
3	704761	ELEMENT - U-SHAPE, 120V/750W
4	705846	FAN BLADE, RADIAL 6-1/4"
6	705847	FAN BLADE, RADIAL 4"
7	706400B	MOTOR, SHADED POLE
8	12-0003807-000	BRACKET, MOTOR
	408902	FINGE NUT

REPLACEMENT PARTS RIP-1 AUTO HUMIDITY

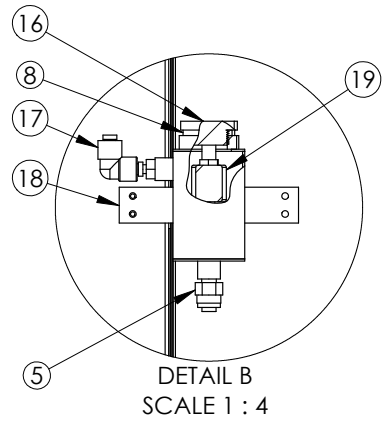
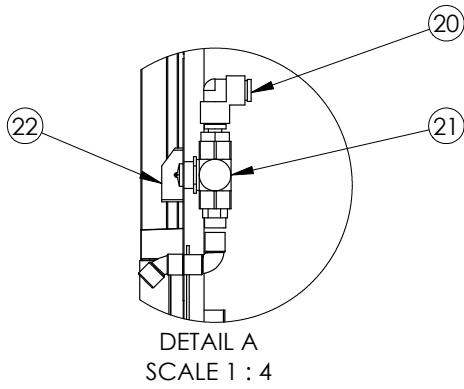
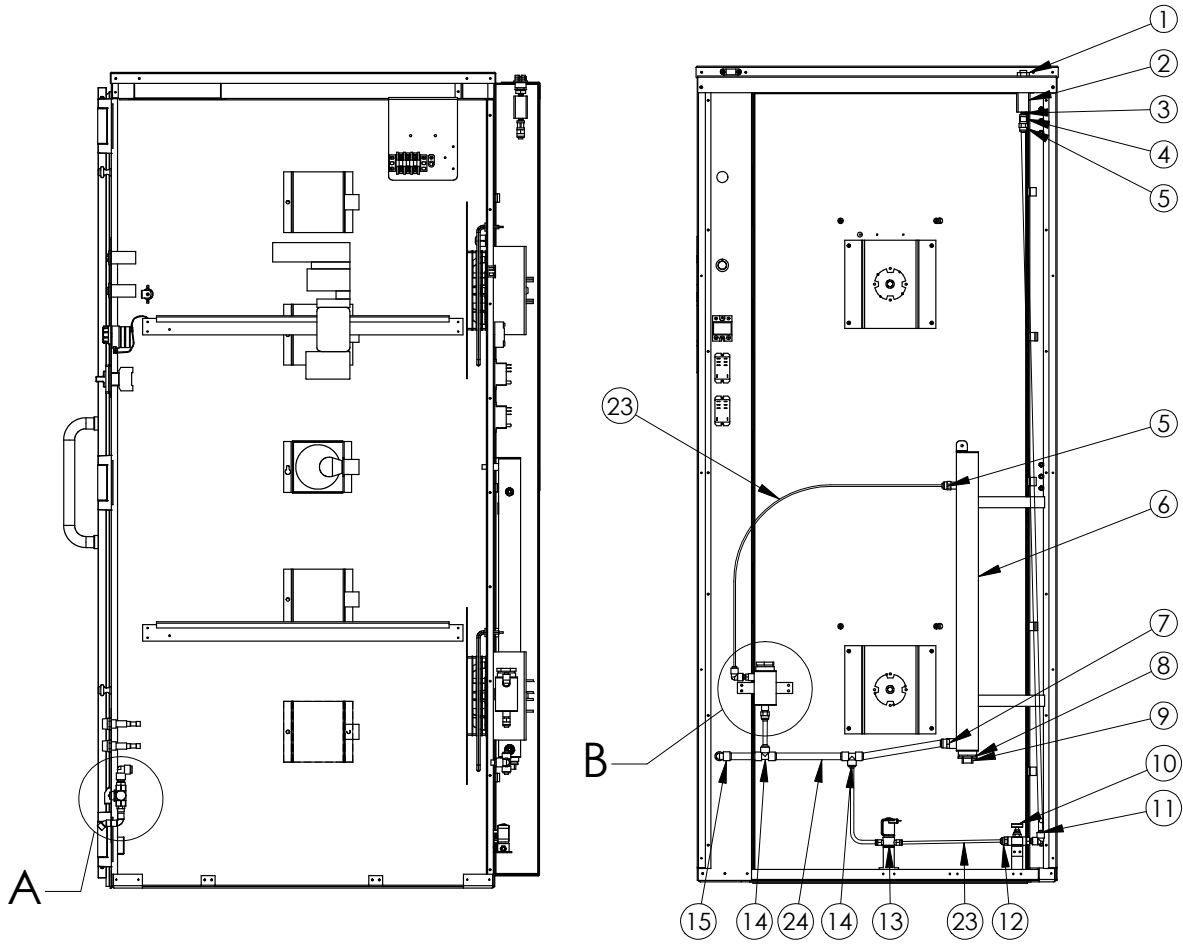

REPLACEMENT PARTS RIP-1 AUTO HUMIDITY

ITEM NO.	PART NUMBER	DESCRIPTION	QTY
1	701915	BRASS FTG BULKHEAD ADAPTOR 1/8	1
2	701960	AQUA-FLOW #C-25	1
3	701508	S/S FTG NIPPLE 1/8 X 3	1
4	701540	BRASS PIPER COUPLER 1/8"	1
5	701016	NYLON MALE CONNECTOR PP4MC2	3
6	11-0000511-000	AUTO HUMIDITY STEAM CHAMBER	1
7	701012	NYLON MALE CONNECTOR PP6MC6	1
8	305213	GASKET FOR STEAM; ADAPT-O-MATIC	2
9	704300	ELEMENT, IMMERSION 120V/1500W	1
10	705786	NEEDLE VALVE DC 3000	1
11	701015	NYLON SWIVEL ELBOW PP4MES4	1
12	701027	NYLON FITTING PP4MC4	1
13	705864	SOLENOID VALVE REG. STEAM & HUMIDITY	1
14	701020	NYLON UNION TEE PP6TU4	2
15	701024	NYLON ELBOW UNION PP6EU6	1
16	701929	BRASS FTG TANK NUT CTR/HOLE	1
17	701019	NYLON SWIVEL ELBOW PP4MES2	1
18	11-0000510-000	AUTO HUMIDITY FLOAT CHAMBER	1
19	705476	SWITCH FLOAT LIQUID LEVEL	1
20	701018	NYLON SWIVEL ELBOW PP6MES6	1
21	701930	VALVE BALL 3/8 X 3/8 IH4	1
22	701931	KNOB, FOR STEAM BALL VALVE	1
23	701032	1/4" NYLON TUBING	
24	701034	3/8" NYLON TUBING	

WIRING DIAGRAM RIP-1 WITH AUTOFILL

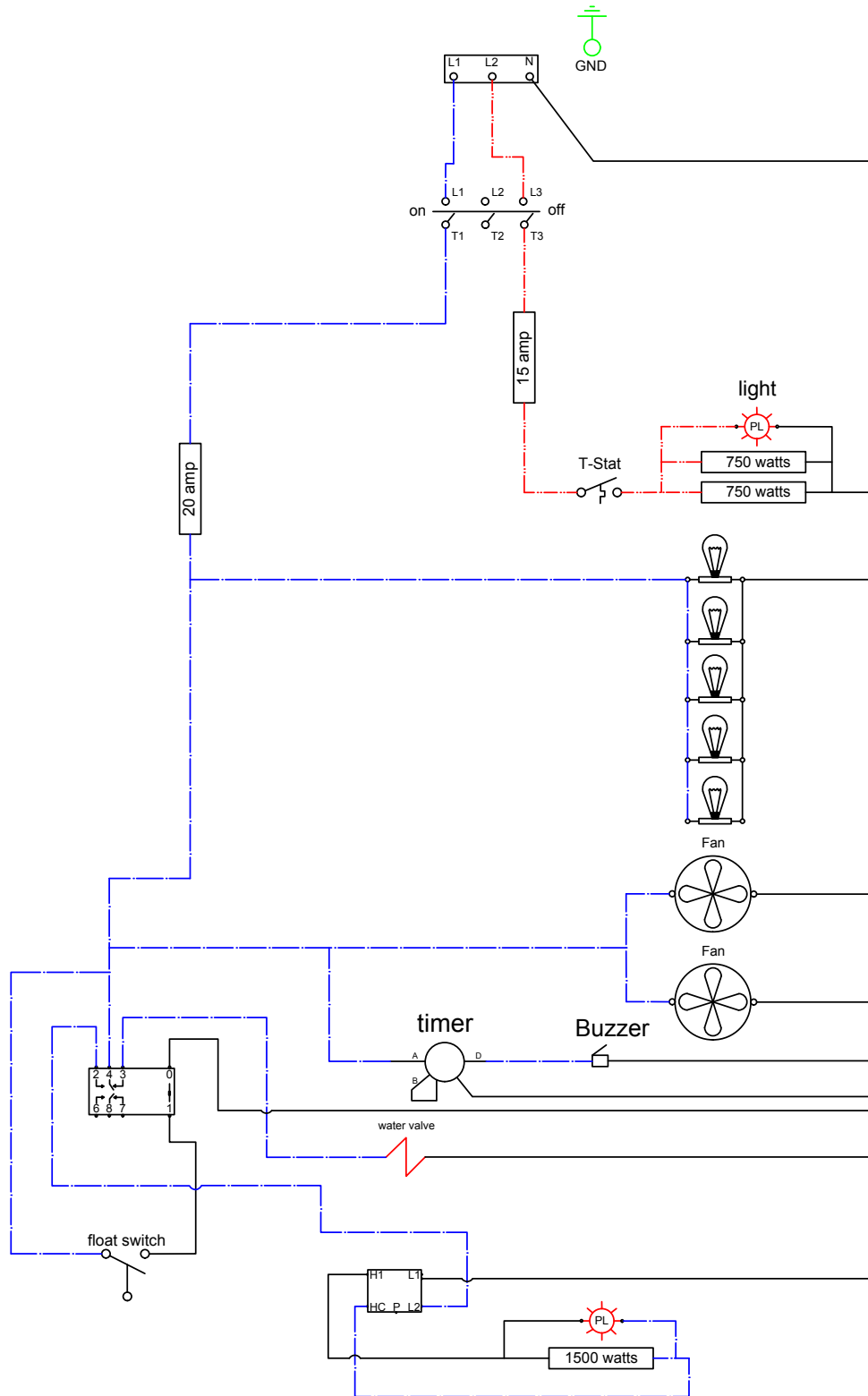

WIRING DIAGRAM RIP-2 WITH AUTOFILL

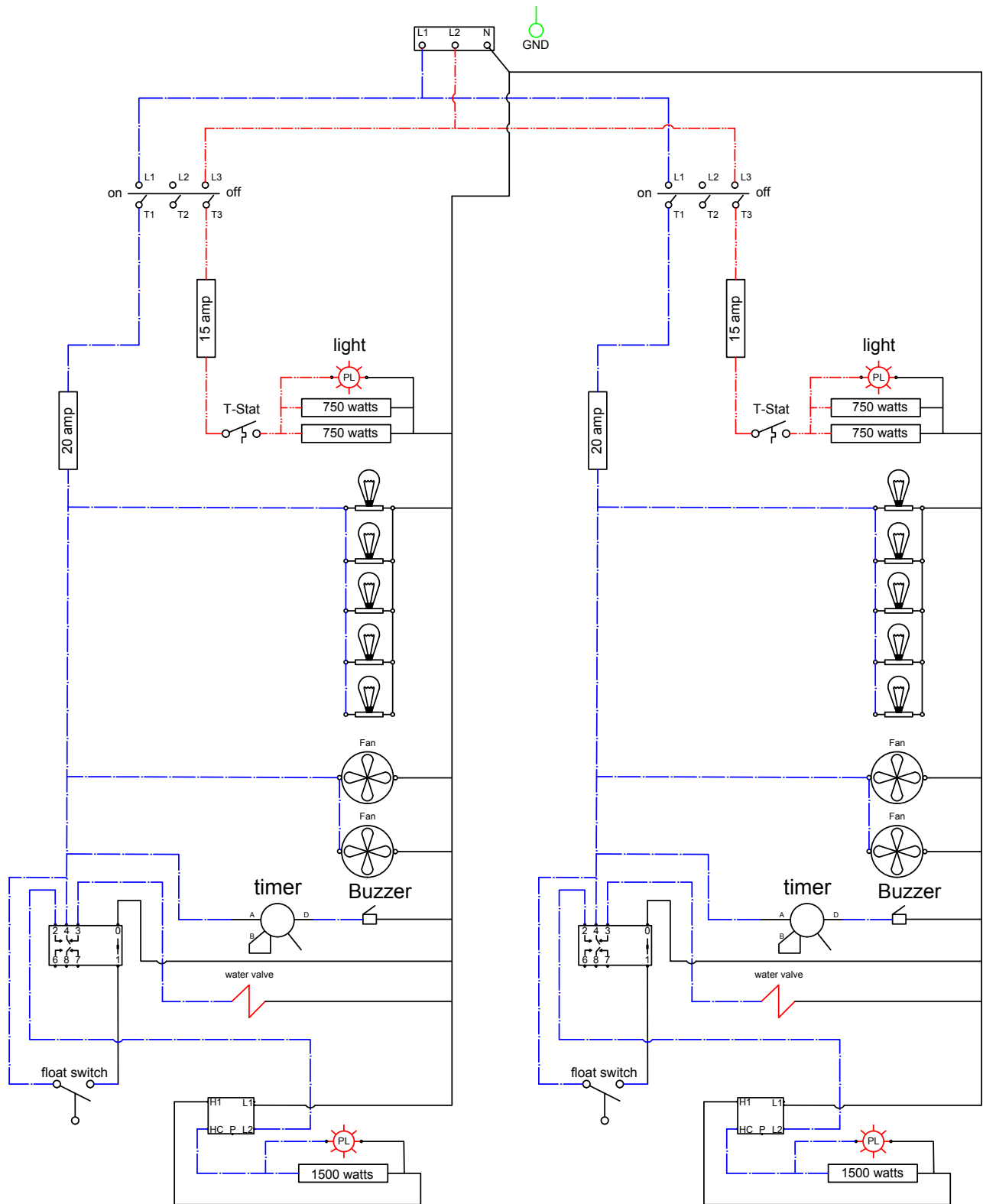

PIPER PRODUCTS, INC. LIMITED WARRANTY

Piper Products, Inc. warrants to the original purchaser that its equipment will be free from defects in the materials and/or parts for a period of 12 months from date of shipment and reported to the factory.

The purchaser is responsible for having equipment properly installed, operated under normal conditions with proper supervision and to perform periodic preventative maintenance. Equipment failures caused by inadequate water quality, improper cleaning, harsh chemicals, or acids are not covered under warranty.

The manufacturer's obligation under this warranty shall be the replacement or repair of defective parts within the warranty period. Excessive labor (more than 1/2 hour) required to access Piper equipment built into cabinets, tables or structures by others, is NOT covered under labor warranty. Example: Piper multiple- or single-well food wells. All labor shall be performed during regular working hours. Overtime premium will be charged to buyer. After thorough examination, the decision of the Piper Products Service Department shall be final.

Any defective parts to be repaired or replaced must be returned to Piper Products, Inc., 300 South 84th Avenue, Wausau, WI 54401, transportation charges prepaid, and they must be properly packed and tagged. The serial and model number of the equipment and date of original installation of such equipment must be given. However, after one year we will not assume any responsibility for any expenses (including labor) incurred in the field incidental to the repair or replacement of equipment covered by this warranty. Our obligation hereunder to repair or replace a defective part is the exclusive remedy for breach of this warranty; and we will not be liable for any other damages or claims, including consequential damages.

If, upon inspection by Piper Products, Inc. or its Authorized Service Agency, it is determined that this equipment has not been properly installed or has not been used in an appropriate manner, has been modified, has not been properly maintained, the warranty will be void. Also, if the nameplate or other identifying marks have been removed, defaced or changed or the unit has been repaired or altered by persons other than expressly approved by Piper Products, Inc., the warranty will be void. If the equipment has been subjected to misuse or misapplication, neglect, abuse, accident, damage during transit or delivery, fire, flood, riot or acts of God, then this warranty shall also be void. When any situation occurs which voids the warranty the manufacturer shall not be liable for any damage to any person or any property which may result from the use of the equipment thereafter.

Warranty is limited to Piper manufactured products only and does not apply to other equipment which may be connected to or installed within.

No representative, dealer, distributor or any other person is authorized or permitted to make any other warranty or obligate Piper Products, Inc. to any liability not strictly in accordance with this policy.

This warranty is in lieu of all other warranties expressed or implied, including any warranty of merchantability, and fitness for a particular purpose. Piper Products does hereby exclude and shall not be liable to purchaser for any consequential or incidental damages including but not limited to damages to property, damages for loss of use, loss of time, loss of profits or income, resulting from any breach of warranty.

PIPER

The Food-Focused Equipment Company

Piper Products, Inc
300 South 84th Avenue
Wausau, WI 54401
Phone: 715-842-2724 . FAX: 715-842-3125