

# INSTALLATION AND OPERATION INSTRUCTIONS

## CUSTOM PASS-THRU BACK BAR CABINET — SELF CONTAINED AND REMOTE

### MODEL NOS.

PS Series  
PR Series

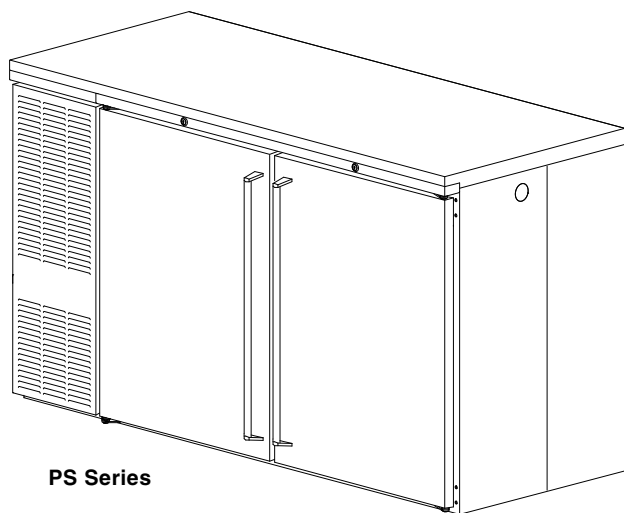

PS Series

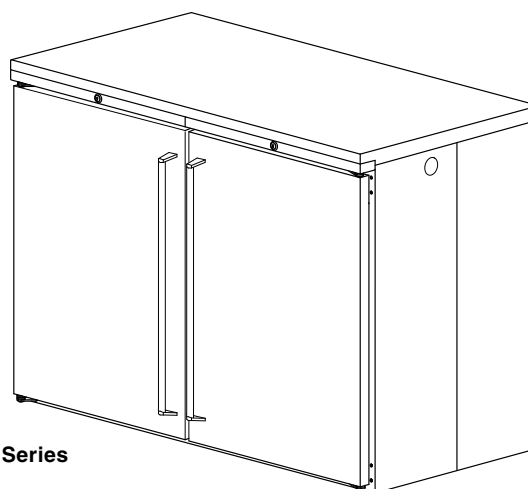

PR Series

### IMPORTANT INFORMATION

To register your product, visit our web site at ([www.perlick.com](http://www.perlick.com)). Click on “Commercial”, then “Service”. You will see the link to “Warranty Registration Form”. You must complete and submit this form or the installation date will revert back to the ship Date.

This manual has been prepared to assist you in the installation of your Cabinet and to acquaint you with its operation and maintenance.

We dedicate considerable time to ensure that our products provide the highest level of customer satisfaction. If service is required, your dealer can provide you with a list of qualified service agents. For your own protection, never return merchandise for credit without our approval.

We thank you for selecting a Perlick product and assure you of our continuing interest in your satisfaction.

**WARNING: When lifting, the full weight of the cabinet must be supported. Lift from the cabinet base and not from the top. Improper lifting can result in severe damage to the cabinet.**

### Table of Contents

<b>PREPARING THE CABINET</b>	
Specifications .....	2,3
List of Included Parts.....	4
Tools Required .....	4
Plumbing.....	4
Electrical .....	4
Uncrating and Inspection.....	4
Placing the Cabinet .....	4
Leveling the Cabinet.....	4
Installing Legs .....	4
Installing the Base Plate.....	4
Electrical Condensate Evapaway Kit .....	4
Refrigeration and Temperature Control.....	5
Cleaning the Cabinet.....	5
Cleaning Stainless Steel .....	5
Replacement Parts.....	6
Reversing Door Hinge.....	7
Wiring Diagram.....	8



# Installation and Operating Instructions

## Sizes and Specifications Custom Pass-Thru Cabinets – Self Contained

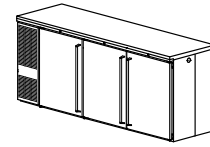
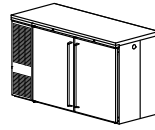

MODEL NOS.	PS60	PS84	
NUMBER OF DOORS	2 Door	3 Door	
CABINET DIMENSIONS	Length - Inches (mm)	60" (1524)	84" (2134)
	Depth - Inches (mm)	26 <sup>3</sup> / <sub>4</sub> " (629)	26 <sup>3</sup> / <sub>4</sub> " (629)
	Height - Inches (mm)	34 <sup>1</sup> / <sub>2</sub> " (876)	34 <sup>1</sup> / <sub>2</sub> " (876)
CASE CAPACITY (based on 12oz. Long Neck bottle)	15	24	
CONDENSING UNIT H.P.	1/4	1/3	
RUNNING LOAD - AMPS	5.7	7.8	
SHIP WT. Lbs. (kg.)	380 (172)	490 (222)	
INTERIOR	<b>Door sill:</b> High strength polyethylene. <b>Door pan and ceiling:</b> High strength polystyrene. <b>Floor pan and Walls:</b> Stainless steel. Includes pilasters, (2) vinyl coated shelves and floor rack per door, and interior lights.		
EXTERIOR	Front, back, top and sides stainless steel. Bottom galvanized steel. See optional accessories for door & grille finishes.		
DOOR HINGING	Stainless steel hinges with standard locations as illustrated. For special hinging specify hinge locations starting from left to right. Field reversible		
DOOR HARDWARE	<b>Door handles:</b> Choice of full length stainless steel, classic 6" black vinyl wrapped pull or top mounted stainless steel pull tab. <b>Lock finish:</b> chrome		
REFRIGERATION	R-134a capillary tube-type. Aluminum fin and copper tube evaporator, epoxy coated coil. Adjustable temperature control. Self-defrosting. Pull-out condensing unit for service and cleaning. Compressor left, standard.		
ELECTRICAL	115V, 60Hz., 1 phase AC. Furnished with 3-prong, 6 foot NEMA5-15 P cord which exits through knock-out in bottom of condensing unit compartment. Contact Perlick for other voltage/frequency requirements.		
PLUMBING	Cabinet comes with 4 feet of 1/2" vinyl tubing for evaporator drain. The tubing exits from the center bottom of the cabinet thru a 15/16" Dia. hole in back of the mullion.		
INSULATION	Foamed-in-place polyurethane, 2" walls, 1 1/2" top.		
OPTIONAL ACCESSORIES & MODIFICATIONS	<ul style="list-style-type: none"> <li>• Leg set</li> <li>• Tapping kit - 3 door only</li> <li>• Laminated top</li> <li>• Laminated ends</li> <li>• Brass hardware (classic &amp; full length only)</li> <li>• Base plates</li> <li>• Condensate Evapaway kit</li> </ul>	<p><b>Door finishes</b></p> <ul style="list-style-type: none"> <li>Black vinyl coated</li> <li>Stainless steel</li> <li>Customer choice of laminate</li> <li>Painted in color of choice</li> <li>Prepared for field lamination</li> <li>Glass door with black vinyl coated frame</li> <li>Glass door with stainless steel frame</li> <li>Glass door with laminated frame</li> </ul>	<p><b>Grille finishes</b></p> <ul style="list-style-type: none"> <li>Black vinyl coated</li> <li>Stainless steel</li> <li>Customer choice of laminate</li> <li>Painted in color of choice</li> </ul>

NOTE: This equipment is intended for the storage and display of non-potentially-hazardous bottled or canned products only.

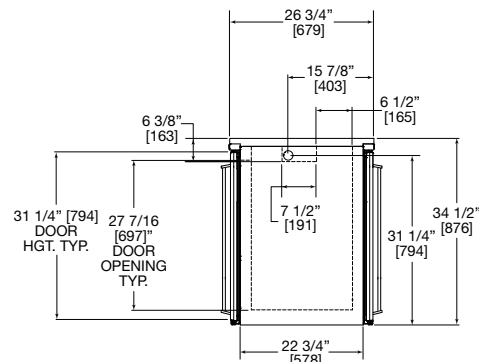
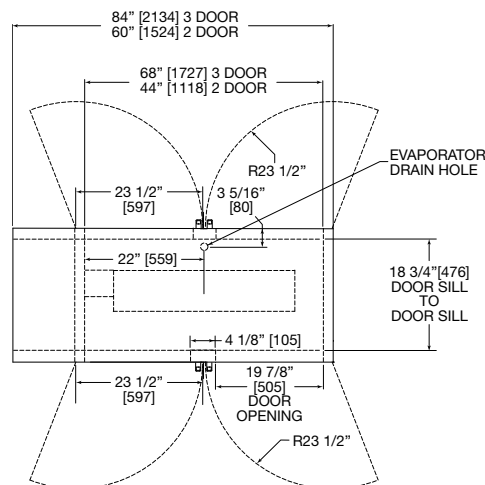

Perlick is committed to continuous improvement. Therefore, we reserve the right to change specifications without prior notice.

# Installation and Operating Instructions

## Sizes and Specifications, Custom Pass-Thru Cabinets – Remote

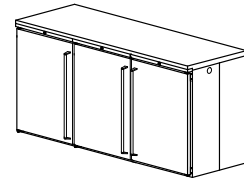
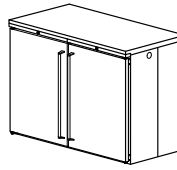

MODEL NOS.	PR48	PR72	
NUMBER OF DOORS	2 Door	3 Door	
CABINET DIMENSIONS	Length - Inches (mm)	48" (1219)	72" (1829)
	Depth - Inches (mm)	26 <sup>3</sup> / <sub>4</sub> " (629)	26 <sup>3</sup> / <sub>4</sub> " (629)
	Height - Inches (mm)	34 <sup>1</sup> / <sub>2</sub> " (876)	34 <sup>1</sup> / <sub>2</sub> " (876)
CASE CAPACITY (based on 12oz. Long Neck bottle)	15	24	
AMPS	.9	.9	
EVAPORATOR CAPACITY@20° F (BTU/HR)	1900	2300	
SHIP WT. Lbs. (kg.)	310 (141)	400 (181)	
INTERIOR	<b>Door sill:</b> High strength polyethylene. <b>Door pan and ceiling:</b> High strength polystyrene. <b>Floor pan and Walls:</b> Stainless steel. Includes pilasters, (2) vinyl coated shelves and floor rack per door, and interior lights.		
EXTERIOR	Front, back, top and sides stainless steel. Bottom galvanized steel. See optional accessories for door finishes.		
DOOR HINGING	Stainless steel hinges with standard locations as illustrated. For special hinging specify hinge locations starting from left to right. Field reversible		
DOOR HARDWARE	<b>Door handles:</b> Choice of full length stainless steel, classic 6" black vinyl wrapped pull or top mounted stainless steel pull tab. <b>Lock finish:</b> chrome		
REFRIGERATION	Aluminum fin and copper tube evaporator, epoxy coated coil. Factory installed expansion valve. Choice of R22, R404A or R134a. Copper tube connection stubbed out left side of evaporator assembly. Suction line accepts 3/8" O.D. copper tubing. Liquid line accepts 1/4" O.D. copper tubing.		
ELECTRICAL	115V, 60Hz., 1 phase AC. Contact Perlick for other voltage/frequency requirements.		
PLUMBING	Cabinet comes with 4 feet of 1/2" vinyl tubing for evaporator drain. The tubing exits from the center bottom of the cabinet thru a 15/16" Dia. hole in back of the mullion.		
INSULATION	Foamed-in-place polyurethane, 2" walls, 1 1/2" top.		
OPTIONAL ACCESSORIES & MODIFICATIONS	<ul style="list-style-type: none"> <li>• Leg set</li> <li>• Tapping kit - 3 door only</li> <li>• Laminated top</li> <li>• Laminated ends</li> <li>• Brass hardware (classic &amp; full length only)</li> <li>• Caster sets</li> <li>• Base plates</li> <li>• Floor access kit</li> </ul> <p style="text-align: center;"><b>Door finishes</b></p> <ul style="list-style-type: none"> <li>Black vinyl coated</li> <li>Stainless steel</li> <li>Customer choice of laminate</li> <li>Painted in color of choice</li> <li>Prepared for field lamination</li> <li>Glass door with black vinyl coated frame</li> <li>Glass door with stainless steel frame</li> <li>Glass door with laminated frame</li> </ul>		

NOTE: This equipment is intended for the storage and display of non-potentially-hazardous bottled or canned products only.

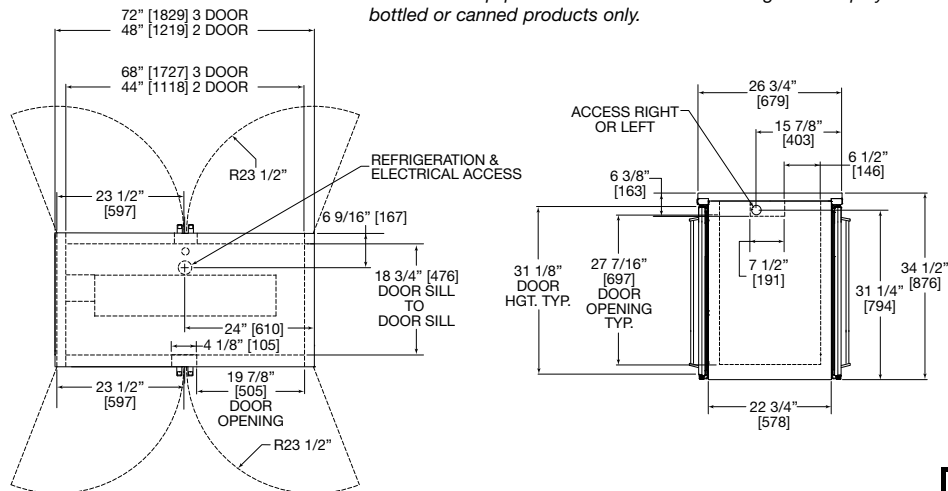

Perlick is committed to continuous improvement. Therefore, we reserve the right to change specifications without prior notice.



# Preparing the Cabinet for Use – Pass-Thru Back Bar Cabinets

---

## Parts List

---

- (2) Shelves plus (1) Floor Rack-per door.
- Shelf Clips.

## Suggested Tools

---

- #2 Phillips Screwdriver.
- 10" Crescent Wrench.
- 9/16" Allen Wrench.
- 5/16" and 3/8" Hex Socket.
- Power Drill or Driver.

## Plumbing

---

Before operating the cabinet, the condensate drain tube (furnished) must be connected. One end is attached to the barbed elbow on the evaporator condensate pan. The other end is inserted through evaporator drain hole and exits the bottom of the cabinet. The drain hole is located in the cabinet floor pan, behind the vertical door mullion.

The drain tube must be placed over a floor drain or into a condensate management system such as a "CONDENSATE EVAPAWAY" pan and heater.

## Electrical

---

The cabinet must be connected to a separately fused power source (see electrical specification plate) and grounded in accordance with National and Local Electrical Codes. Caution: Do not attempt to operate the equipment on any other power source than that listed on the Electrical Specification plate.

## Uncrating and Inspection

---

Remove all crating material before operating. Carefully inspect cabinet for hidden damage. If damage is discovered, file your claim immediately with the transportation company. Perlick is not responsible for damage in transit.

## Installing Legs (Optional)

---

Attach four legs to the cabinet bottom. Use the supplied 1/4"- 20 x 3/4" hex head self-tapping machine screws.

## Placing the Cabinet

---

Position the cabinet into place using rollers when necessary. **Important:** Proper air flow around the condensing unit is necessary for efficient operation. Never obstruct the air flow in and out of the condensing unit.

## Leveling the Cabinet

---

When the cabinet is in place, check installation with carpenter's level. When level front to back and left to right, accumulated water will drain out of cabinet evaporator drain.

## Electric Condensate Evapaway Kit (Optional)

---

A 115-volt electric condensate pan can be installed underneath the cabinet to collect and evaporate the condensate from the cabinet evaporator. A 6 foot - 3 prong plug is included. A separate circuit should be provided for the heater. The kit can be used only on cabinets with 4" minimum legs. It can not be used with platform or baseplate kits..

## Installing Base Plate (Optional)

---

Attach brackets to cabinet bottom in holes provided. Attach base plate to brackets. (See separate instructions, provided with kit). When returning cabinet to upright position, be careful not to bend brackets.

## WARNING! — Self Contained Units

---

*To avoid compressor damage, after returning cabinet to an upright position, let unit stand for 24 hours before plugging it in and running the unit.*



# General Information

## Refrigeration and Temperature Control

The cabinet is equipped with a heavy-duty refrigeration system designed to automatically maintain a storage temperature of approximately 38 degrees F.

### Adjusting the temperature

The temperature control is inside the cabinet on the left-hand side of the evaporator fan panel assembly. You will need a screwdriver to turn the adjusting screw. Make small adjustments until the desired temperature is achieved.

- **Colder Temperatures:**  
Turn the adjusting screw clockwise (to the right).
- **Warmer Temperatures:**  
Turn the adjusting screw counterclockwise (to the left).
- **Temperature Control “OFF”:**  
Turn the adjusting screw completely counterclockwise to the “O” position until a click is noted.

The condenser fan motor turns off and on with the compressor. The evaporator fan motor is on all the time.

#### NOTE:

Cabinet Temperatures lower than 34° will not allow for proper defrosting of the evaporator coil. If defrosting is necessary, turn the control knob to the OFF position until coil is defrosted.

## Cleaning the Cabinet

Use a mild detergent and water to clean the inside and outside of the cabinet. Dry thoroughly. Never use a scouring pad or abrasive cleanser.

**NOTE:** An industrial strength, commercial cleaner can be used to clean the outside of painted cabinets.

## Cleaning the Condenser

Use a long handled, stiff brush to clean the dirt from the front surface of the condenser. Keeping the condenser free from dust and dirt will ensure efficient operation.

**CAUTION:** Do not bend the fins while brushing the front of the condenser.

## Condenser

The condenser (located behind the front grille cover) should be inspected every 30 days and cleaned, if necessary.

Failure to keep the condenser clean will cause a loss in condensing unit efficiency.

## Recommended Cleaning Agents

JOB	CLEANING AGENT*	COMMENTS
Routine Cleaning	Soap, ammonia, detergent	Apply with sponge or cloth. Can be used on all finishes.
Fingerprints and smears	Areal 20, Lac-O-Nu, Lumin Wash, O’Cedar Cream Polish	Provides barrier film to minimize fingerprints. Can be used on all finishes.
Stubborn stains and Discolorations	Allchem Concentrated Cleaner, Samae, Twinkle, Zud Restoro, Grade F or FFF Italian Pumice, Whiting or Talc, Liquid Nu Steel, Copper’s or Revere Stainless Steel Cleaner, Lumin Cleaner, Sta-Clean, Cameo Copper Cleaner, Allen Polish Highlite, Penny-Brite, Copper Brite	Rub lightly, using dry or damp cloth in the direction of polish lines on the stainless steel.

\* Use of propriety names is intended only to indicate a type of cleaner and does not constitute an endorsement. Omission of any proprietary cleaner does not imply its inadequacy. All products should be used in strict accordance with instructions on the package. NOTE: Do Not Use Steel Wool or Scouring Pads to clean stainless steel.

# Replacement Parts — Pass-Thru Back Bar Cabinets

MODEL NOS.	PS60	PS84
	PR48	PR72
<b>Condensing Units (PS Only)</b>		
Condensing unit 115 volt, 60 hz.	C22647	C22646
Condensing unit	515301063	515301062
Compressor	513200314	513200003
Fan motor assembly	515315009	515315009
Condenser coil	15352019	15352019
Terminal board	519100088	519100088
Overload protector	US-PB10HBX1	US-PB12HBX1
Relay	US-PB10HBX1	US-PB12HBX1
Capacitor	US-PB10HBX1	US-PB12HBX1
<b>Evaproator Assembly</b>		
Self Contained (PS) complete	66071AEP	66072AEP
Remote (PR) complete	66073AEP	66074AEP
Evaporator coil	C17511-1EP	C17511-2EP
Fan blade	57699	57699
Fan motor	C15239A	C15239A
Evaporator fan guard	65557	65557
Temperature control	61283	61283
Bulb clamp	C6634	C6634
Wire harness, compressor bottom	65560	65560
Wire harness, evaporator	65561	65561
Wire harness, light jumper	65051A	65051A
Light bulb	C15046	C15046
Light bulb guard	65099-1	65099-1
Light socket	63484	63484
Light switch	63303	63303
Lock	63762	63762
Space, lock	63761-1	63761-1
Lock rail	65432-24SS or 65432-24	65432-24SS or 65432-24
Grille rail	65432-12SS or 65432-12	65432-12SS or 65432-12
Condenser pan	65565-1	65565-1
Condenser end panel	66215-1SS	66215-1SS
Grille, black	66210-12	66210-12SS
Grille, SS	66210-12SS	66210-12
Condenser housing back	65435-12SS	65435-12SS
Door sill	65500-1	65500-1
Door handle	Several Options - Contact Factory	
Door gasket	66237-4	66237-4
Cabinet hinge group left	66264L	66264L
Cabinet hinge group right	66264R	66264R
Hinge pin	63679-1	63679-1
End shelf kit (std. flat)	57928	57928
Center shelf kit (std. flat)	—	57929
Left or right shelf (std. flat)	62307-2	62307-2
Center shelf (std. flat)	—	62308-2
Pilaster strip	C19271-1	C19271-1
Shelf clip	C15875	C15875
*Replacement door	RD-NL2	RD-NL2

\*Contact Perlick Milwaukee for complete door replacement. Cabinet serial no. required.



Perlick is committed to continuous improvement. Therefore, we reserve the right to change specifications without prior notice.

# Reversing Door Hinge

## Tools Required

- #3 Phillips Screwdriver.
- 1/16" Allen Wrench.
- Flathead Screwdriver

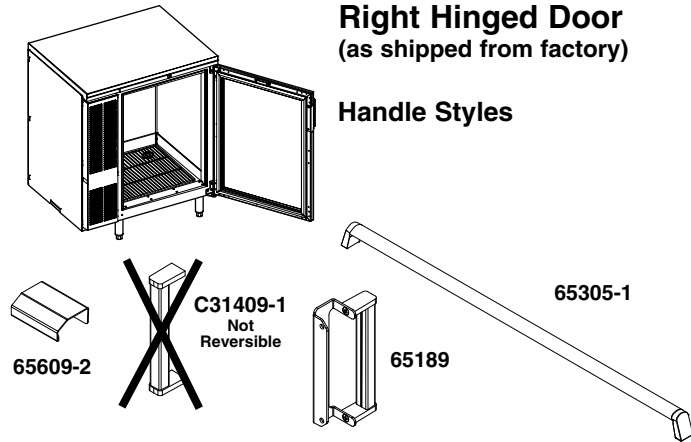

## Operations to Perform on Cabinet

**STEP 1:**  
Remove bottom hinge pin from assembly.

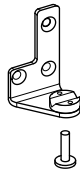

**STEP 2:**  
Carefully lift and tilt out door assembly from the unit and set aside.

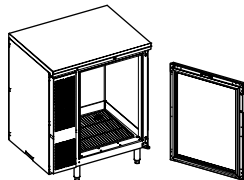

**STEP 3:**  
Remove lock rail from cabinet, requires removal of four screws.

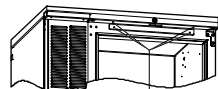

**STEP 4:**  
Remove top hinge pin.  
Remove top and bottom hinge brackets from the unit.

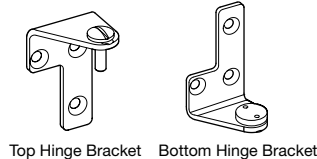

**STEP 5:**  
Remove hinge bushing from bottom hinge bracket and assemble to top hinge bracket.



**STEP 6:**  
Taking care not to scratch the surface, remove hole plugs from the left hinge holes.

**STEP 7:**  
Insert hole plugs into vacant right hinge holes.

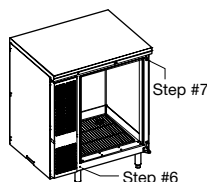

**STEP 8:**  
Re-assemble hinge brackets to unit. Bottom right bracket is assembled as the top left bracket. Top right bracket is assembled as the bottom left bracket.

**STEP 9:**  
Re-insert top hinge pin.

**STEP 10:**  
Re-assemble lock rail from STEP #3

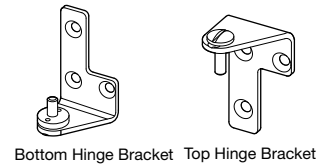

## Operations to Perform on Door

**STEP 11:**  
Remove bottom door hinge bracket from door assembly and remove door hinge bushing from bracket.  
Re-assemble door hinge bracket to previous position, without bushing.

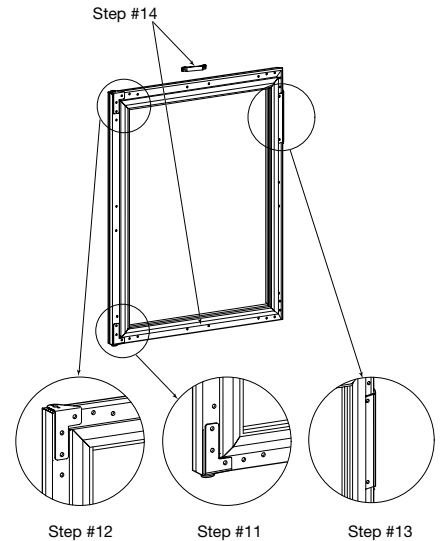

**STEP 12:**  
Remove top door hinge bracket from door assembly and assemble door hinge bushing from STEP 11 to bracket. Re-assemble door hinge bracket to previous position with bushing attached.

**STEP 13:**  
**Door with full length SS handle:**  
There is no need to remove door handle. It will be positioned correctly when door is reversed.

**Door with SS pull tab or handle with wrap-around bracket:**  
Remove the two screws mounting the handle and reposition to appropriate location on the opposite side of the door.

**STEP 14:**  
Remove lock retainer and install on opposite end of door.

**STEP 15:**  
What was the door top is now the door bottom. Carefully lift the door onto the hinge brackets of the cabinet. The two hinge bushings should meet. Reinsert the bottom hinge pin to complete the door switching operation.

# Wiring Diagram – Custom Back Bar Cabinets

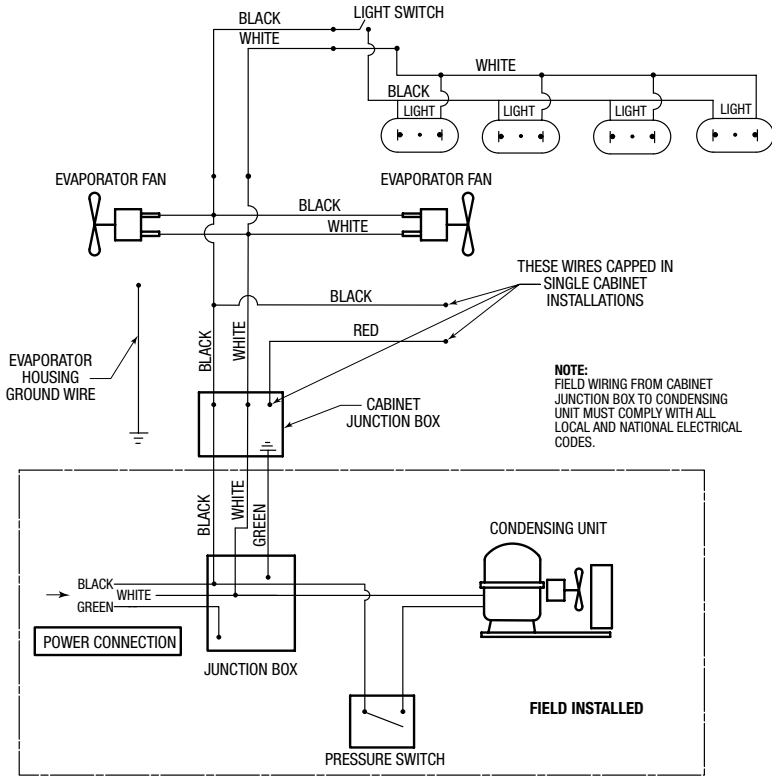

**PS Series Self-Contained  
2 and 3 Door**

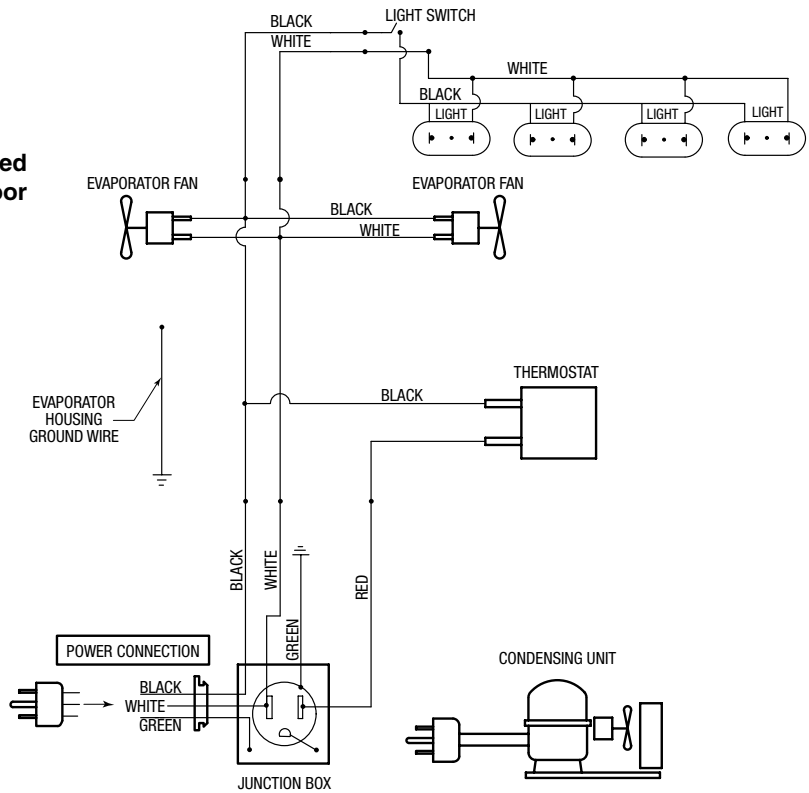

8300 West Good Hope Road • Milwaukee, WI 53223 • Phone 414-353-7060 • Fax 414-353-7069  
Toll Free 800-558-5592 • E-Mail: Perlick@Perlick.com • www.Perlick.com

Perlick is committed to continuous improvement. Therefore, we reserve the right to change specifications without prior notice.

Form No. Z2279  
Rev 07.24.10