

INSTALL & OPERATION MANUAL

PRINCE CASTLE FLAME KING BROILER: FK4-NGA-BKNA



TABLE OF CONTENTS

PRODUCT REGISTRATION	2
SAFETY INFORMATION	3
SPECIFICATIONS	4
GENERAL NOTES	5
UNBOXING & ASSEMBLY	8
INSTALLATION	16
OPERATION	21
PARTS IDENTIFICATION	25
CLEANING	26
TROUBLESHOOTING	38
ERROR CODES	39
PARTS LIST	40
WIRING DIAGRAM	51

Training Resources and Videos

Scan the QR code
to access available
tools and resources

or visit [princecastle.com/
products/flame-king-broiler](http://princecastle.com/products/flame-king-broiler)

Call **1-800-722-7853**
for free technical
service support



Prince Castle, a Marmon Foodservice Technologies brand
355 East Kehoe Blvd, Carol Stream, IL 60188
1-800-PCASTLE | info@princecastle.com | princecastle.com

EQUIPMENT REGISTRATION



Thank you for purchasing your equipment from the Marmon Foodservice Technologies family of brands. From technical support to warranty dispatch to replacement parts sales, Marmon Link provides your entire after-sales support for Cornelius, Prince Castle, Silver King, and Angelo Po America equipment.

Registering your equipment will help us keep you up to date on equipment information, preventative maintenance resources, and other topics. Your equipment's warranty will not be affected if you choose to not fill out this form.

To expedite the process, we ask that you have the following:

- The serial numbers of the equipment you purchased.
- The name and email address for a designed store contact.
- The general store information, including address location number.

REGISTER YOUR EQUIPMENT

To Maximize Your Benefits

- * Comprehensive after-sales service
- * Over the phone technicians
- * Quick-ship parts

Complete with:

- * Serial Number
- * Equipment location details



Scan the QR Code

Your equipment serial number will be validated against our database of existing serial numbers. If you are having difficulties entering a valid number, please contact Marmon Link at **1-866-275-6392**.

SAFETY INFORMATION

FOR YOUR SAFETY



Do not store or use gasoline or other flammable vapors or liquids in the vicinity of this or any other appliance.

WARNING



Improper installation, adjustment, alteration, and/or maintenance can cause property damage, injury, or death. Read the installation, operating, and maintenance instructions

SAFETY INFORMATION (CONTINUED)



WARNING

1. Do not store or use gasoline or other flammable vapors or liquids in the vicinity of this or any other appliance.
2. Broiler area must be kept free of combustible materials and the flow of combustion and ventilation air must not be obstructed.
3. Do not use this appliance in an area where a water jet could be used.
4. Do not clean the appliance with a water jet.
5. If the power supply cord is damaged, it must only be replaced by an authorized agent approved by Prince Castle.
6. This appliance must be installed by a qualified installer, in compliance with all national and local regulations and authorities having jurisdiction.
7. This machine must be connected to a grounded electrical supply.
8. Install adjacent to non-combustible surfaces only. See chart for minimum clearances.
9. This appliance is not intended for use by persons with reduced physical, sensory, or mental capabilities or lack of experience and knowledge. All operators of this equipment must be trained in its use.

IMPORTANT:

RETAIN THIS MANUAL IN A SAFE PLACE FOR FUTURE REFERENCE

SPECIFICATIONS

Nominal Power Rating: 120 VAC, 1 PH, 2 AMP, NEMA 5-15

Model: Prince Castle Flame King Broiler

Inlet Pressure: 7.0" WC

Max Energy BTU/hr.: 112,000

Min Energy/BTU/hr.: 88,000

Weight: 482 lbs. (219 kg)



CAUTION

Do not operate the broiler at gas pressures other than those stated here. Doing so will affect the operation of your broiler.



CAUTION

All electrical and gas connections must be in accordance with local electrical codes and any other applicable codes.

Fuel Type	Elevation [ft]	Inlet Pressure [inWC]	Front IR Burner			Rear IR Burner			Tube Burner		
			Orifice Size [#]	HI Pressure [inWC]	LOW Pressure [inWC]	Orifice Size [#]	HI Pressure [inWC]	LOW Pressure [inWC]	Orifice Size [#]	HI Pressure [inWC]	LOW Pressure [inWC]
Natural Gas	Up to 5,400	7.0	48	5.0	2.9	48	5.0	2.9	38	4.8	3.1
Natural Gas	5,400-10,100	7.0	44	5.0	2.9	44	5.0	2.6	38	4.8	3.1

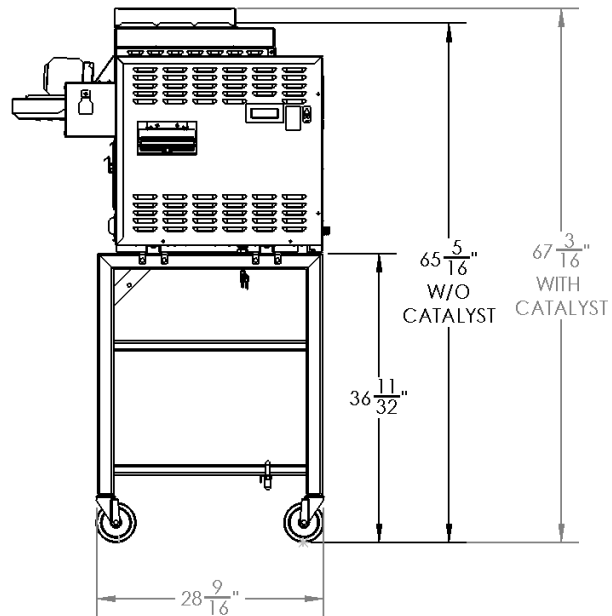
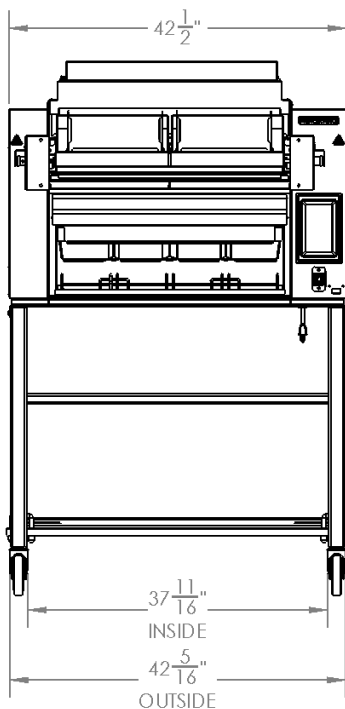
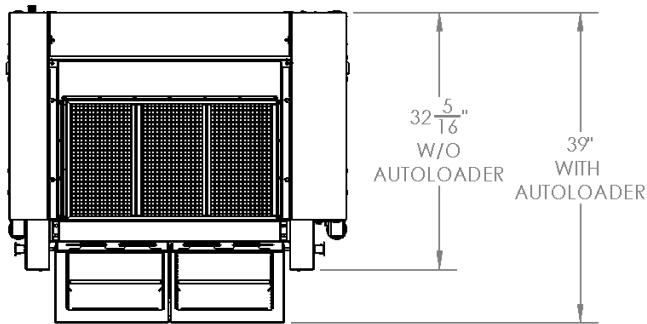

A. GENERAL NOTES

A.1 Description

Deliver consistent, great tasting food with the intuitive Prince Castle Flame King Broiler. This easy-to-operate, four-lane, continuous feed broiler makes cooking and cleaning easier than ever. Its independently controlled top and bottom burners offer precise and consistent cookout temperatures — delivering premium-quality, great-tasting, char-broiled products every time. The intuitive LED touchscreen display simplifies operations and gives crew members easy access to cookout settings.

This manual provides the safety, installation, cleaning and operating procedures for the Prince Castle Flame King Broiler. We recommend that all information contained in this manual be read prior to installing and operating the broiler.

A.2 Warranty Information

The information in this document is intended solely for the use of the intended food service equipment and is controlled directly by Prince Castle. **LIMITED ONE YEAR WARRANTY:** This product is warranted to be free from defects in material and/or workmanship for a period of 12 months from the date of installation; not to exceed 15 months from the date of manufacture. Use of any non-genuine Prince Castle parts voids this warranty. All work must be performed by an authorized Prince Castle Service Agent, except as provided herein. —All labor shall be performed during regular work hours.

Overtime premium will not be covered. —Travel charges are limited to 100 (200 kilometers) round trip, 2 hours travel time, one trip per repair.

—Damage caused by carelessness, neglect, and/or abuse (e.g. using wrong current, dropping, tampering with or altering electrical components, or improper cleaning) is not covered. —Equipment damaged in shipment, by fire, flood or an act of God is not covered. —Damage to coated surfaces is not covered by this limited warranty.

PRINCE CASTLE SHALL NOT BE LIABLE FOR INCIDENTAL OR CONSEQUENTIAL DAMAGES, LOSSES, OR EXPENSES. THIS IS PRINCE CASTLE'S ONLY WARRANTY. PRINCE CASTLE MAKES NO OTHER WARRANTY, EXPRESS OR IMPLIED. ALL IMPLIED WARRANTIES OF MERCHANTABILITY AND/OR FITNESS FOR ANY PARTICULAR PURPOSE ARE HEREBY DISCLAIMED AND EXCLUDED.

355 East Kehoe Blvd.—Carol Stream, IL 60188 USA—Telephone: 630-462-8800—Toll Free: 1-800-PCASTLE

If the unit arrives damaged, contact the carrier immediately and file a damage claim with them. Save all packing materials when filing a claim. Freight damage claims are the responsibility of the purchaser and ARE NOT covered under warranty.

The warranty does not extend to:

- Damage caused in shipment or damage as a result of improper use.
- Use of non-authorized service parts or agents.
- Installation of electrical service.
- Normal maintenance and consumables as outlined in this manual.
- Malfunction resulting from improper maintenance not in accordance with the steps contained in this manual and any applicable training.
- Damage from moisture into electrical components.
- Damage from tampering with or removal of any safety device.

IMPORTANT!

Keep these instructions for future reference. If the unit changes ownership, be sure this manual accompanies the equipment.

IMPORTANT

Prince Castle reserves the right to change specifications and product design in accordance with the general terms and conditions outlined in the BURGER KING®/Vendor agreement. Such revisions do not entitle the buyer to corresponding changes, improvements, additions or replacements for previously

A. GENERAL NOTES (CONTINUED)

A.3 Service / Technical Assistance

If you experience any problems with the installation or operation of your broiler, contact your local authorized Prince Castle distributor.

Fill in the information below and have it handy when calling your authorized service agency for assistance. The serial number is on the broiler rating plate on the back of the unit.

Purchased from: _____

Date of Purchase: _____

Model No.: _____

Serial No.: _____

For the name of your local authorized Prince Castle distributor, please call 1-800-PCASTLE (1-800-722-7853).

Use only genuine Prince Castle replacement parts in your broiler. Use of replacement parts other than those supplied by authorized Prince Castle distributors and service agencies will void the warranty and may significantly alter the performance of your broiler. The use of non-Prince Castle parts is capable of affecting these criteria, and may affect broiler performance, parts longevity, and food safety. Your local authorized Prince Castle distributor and service agent has been factory trained and has a complete supply of parts for your Prince Castle broiler.

You may contact the factory direct at +1-630-462-8800 if you have trouble locating your local Prince Castle distributor.

A.4 Important Safety Information

Throughout this manual, you will find the following safety words and symbols that signify important safety issues with regard to operating or maintaining the equipment:



WARNING

GENERAL WARNING. Indicates information important to the proper operation of the equipment. Failure to observe may result in damage to the equipment and/or bodily injury or death.



WARNING

ELECTRICAL WARNING. Indicates information relating to possible shock hazard. Failure to observe may result in damage to the



CAUTION

GENERAL CAUTION. Indicates information important to the proper operation of the equipment. Failure to observe may result in



WARNING

HOT SURFACE WARNING. Indicates information important to the handling of equipment and parts. Failure to observe

A. GENERAL NOTES (CONTINUED)

A.4 Important Safety Information (Continued)

In addition to the warnings and cautions in this manual, use the following guidelines for safe operation of your Prince Castle Flame King Broiler:

- Read and follow all instructions before using this equipment.
- Install or locate broiler only for its intended use as described in this manual.
- Do not operate this equipment if it has a damaged cord or plug, if it is not working properly or if it has been otherwise damaged.
- This equipment should only be serviced by authorized personnel. Contact your local Prince Castle distributor for adjustment or repair.

Do not connect to a gas supply with a damaged or leaking hose and connector. A gas shut off valve must be used along with a restraint kit.

Use only genuine Prince Castle replacement parts for your broiler. Failure to do so will void the warranty and may significantly alter the performance of your broiler. The use of non-Prince Castle parts may affect broiler performance, parts longevity and safety.

The following warnings and cautions appear throughout the manual and should be carefully observed:

- Turn the boiler off, close the main gas valve, and disconnect the plug before performing any service, maintenance or cleaning on the broiler.
- Always allow the broiler to fully cool before performing any service, maintenance or cleaning. Failure to wait for the broiler to cool fully may result in personal injury.
- The procedure in this manual may include reference to the use of chemical products. The Prince Castle Corporation does not endorse the use of any particular cleaning/degreasing agent. Use only those chemicals that are approved for use in your kitchen.
- The broiler should be grounded according to local electrical codes to prevent the possibility of electrical shock. It requires a grounded receptacle with separate electrical lines, protected by fuses or circuit breakers of the proper rating.
- All electrical and gas connections must be in accordance with local and national codes and any other applicable codes.
- The use of adequate ventilation with this broiler is mandatory. Failure to adequately ventilate this unit and provide safe operating clearances (as specified in this manual) is a fire safety hazard. Follow the instructions for emergency broiler shutdown in the event of an emergency.
- No attempt should be made to operate this appliance in the event of a power failure.

WARNING: ELECTRICAL SHOCK HAZARD. FAILURE TO FOLLOW THESE INSTRUCTIONS COULD RESULT IN SERIOUS INJURY OR DEATH:

- Electrical ground is required on this appliance.
- Check with a qualified electrician if you are in doubt as to whether the appliance is properly grounded.
- Do not use water on or near the broiler. There is a risk of serious injury or death due to electrical shock.

WARNING: HIGH TEMPERATURES WITH HOT SURFACES. FAILURE TO FOLLOW THESE PROCEDURES COULD RESULT IN SERIOUS INJURY:

- Do not attempt to clean, disassemble or perform maintenance on this broiler until it is fully cooled as per the instructions contained in this manual.

B. UNBOXING & ASSEMBLY

B.1 Unboxing

Uncrate the broiler and inspect for shipping damage. Remove the tape securing the machine parts and install the parts in their proper location. If there are obvious or concealed damages to any part of the broiler, please contact your freight carrier. The factory warranty does not cover freight damage.

Recommended Tools
Utility Knife or Scissors
Socket wrench with 9/16" socket

- Remove (3) straps using utility knife or scissors.



- Remove the cardboard top tray.

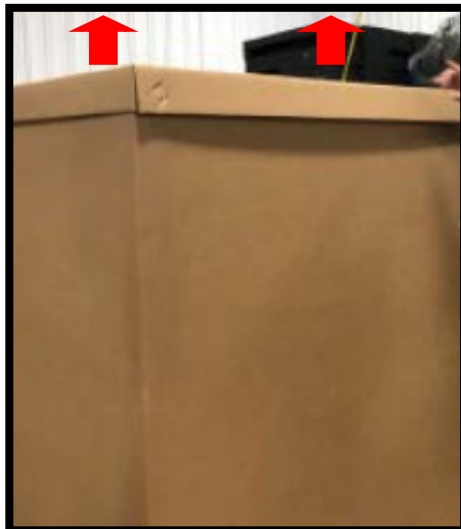

B. UNBOXING & ASSEMBLY

- Remove the (2) corner foam and (2) support wooden beams from the top of the unit.



- Locate the staples (not shown) on (2) corners and the bottom of the cardboard and remove the (2) wraps.



B. UNBOXING

- Cut away the plastic wrap using utility knife or scissors and remove all the boxes from the bottom of the unit.



- Using 9/16" socket, remove (4) bolts used to secure the frame to the skid. This will allow the (4) wooden parts to come loose.

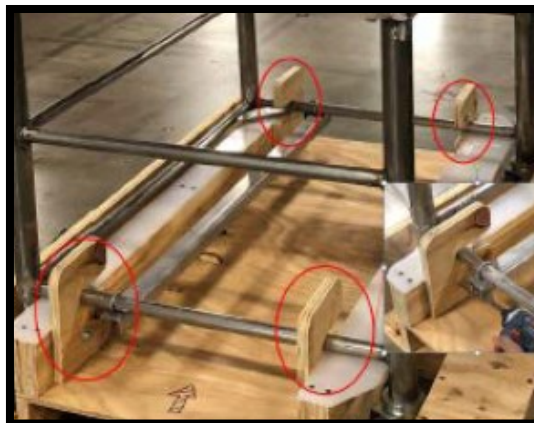

- Install the (2) ramps to the pallet. Line up with casters.



B. UNBOXING & ASSEMBLY

- Push the unit off the pallet, down the ramp in the direction of the arrows on the pallet.



- Locate the foam block on the side cutout and remove it from the unit.

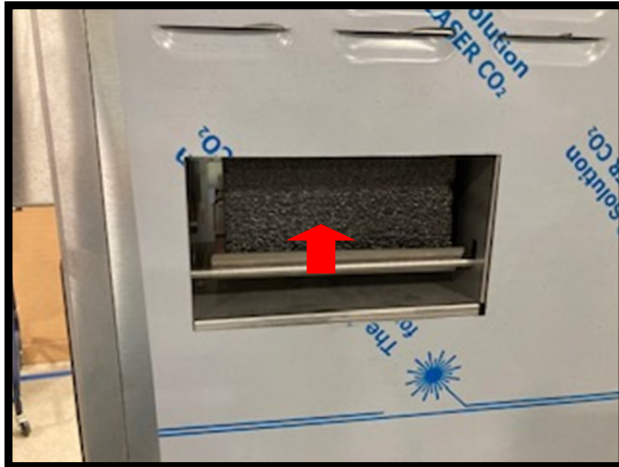

- Remove the foam piece that is below the conveyor belt.



B. UNBOXING & ASSEMBLY

- Remove the packing tape and manual from the unit.



- Remove all protective wrapping (white film) from broiler sheet metal.

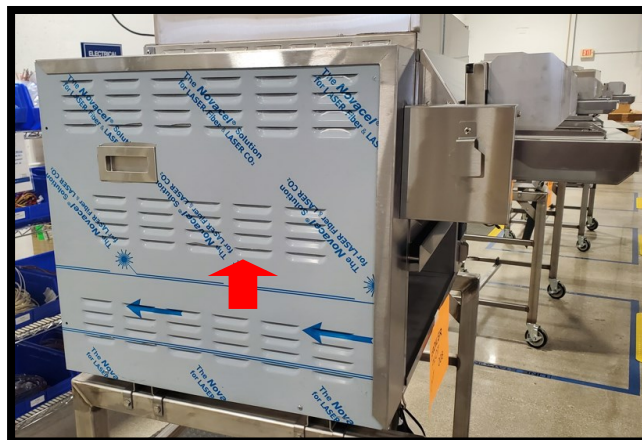

B. UNBOXING & ASSEMBLY

B.2 Included Parts List

Open all the included boxes and make sure all required parts are present before starting assembly.

- **Wire Rack**

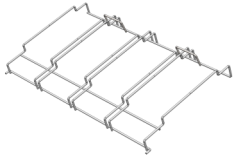

1000-343:
Rack—Holding Bins

- **Pan Holder**

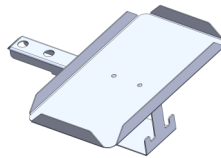

1000-737:
Tray—Pan Holder

- **Impedance Plate**

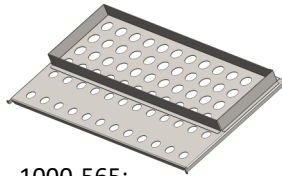

1000-565:
Plate—Impedance

- **Pan Holder**

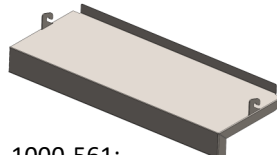

1000-561:
Cover—Upper Exit

- **Rear Parts**

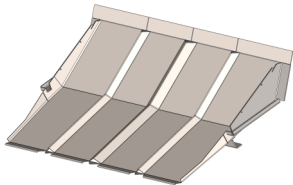

1000-353:
Ramp—Exit

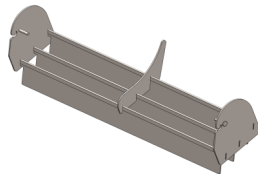

1000-527:
Shield—Heat, Exit Ramp

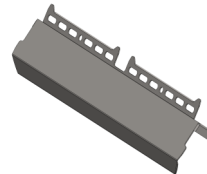

1000-364:
Scraper—Rear

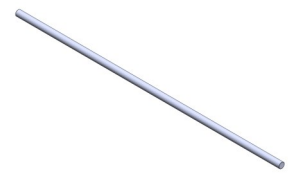

1000-892:
Shaft—Rear Scraper

- **Auto Feeder**

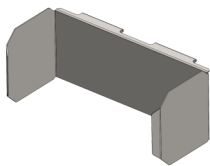

1000-301:
Plate—Limiter, Auto Feeder

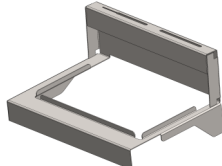

1000-302:
Cover—Left, Auto Feeder

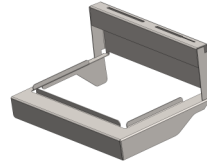

1000-303:
Cover—Right, Auto Feeder

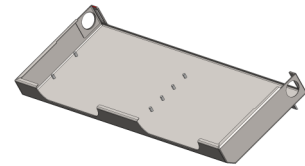

1000-305:
Tray—Main, Auto Feeder

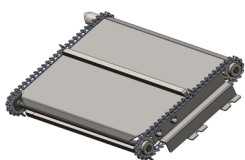

1000-310:
Cartridge—Left, Auto Feeder

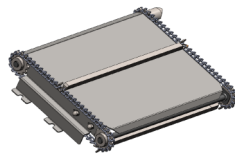

1000-325:
Cartridge—Right, Auto Feeder

B. UNBOXING & ASSEMBLY

B.3 Assembly

- **Landing Zone & Pan Holder**

1. Place front feet of Rack - Pan Holder under side tabs of Tray - Landing Zone and lower into position.
2. Slide Landing Zone Assembly onto bottom surface of Broiler. Push inwards to side tabs contact Broiler.
3. The Tray - Pan Holder can be placed in any of four location on the broiler where the Broiler attaches to the Cart on the Left and Right sides. Slide in the Tray - Pan Holder on a slightly downward angle until it stops. Then tilt upwards into position.

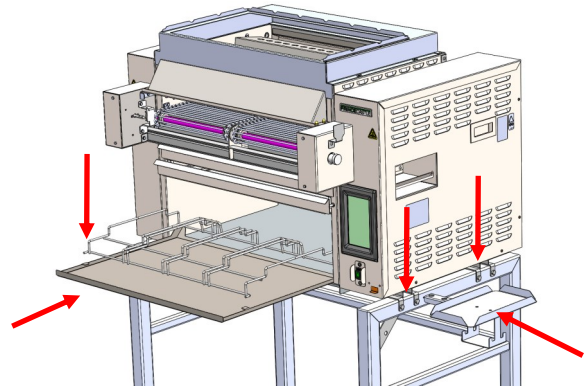

- **Auto Feeder**

1. Rotate Knob Retainer on Auto Feeder side housings and pull out Drive Knobs on both sides.
2. Hook the Tray - Main, Auto Feeder onto mounting hooks. The hooks are located on both sides between the Auto Feed knobs.
3. Place Left and Right Auto Feeder Cartridge into tray. Pass the Drive Coupler thru the hole in the side of the tray and lower onto the locating pins.
4. Lower Left and Right Auto Feeder Covers over the previously installed cartridges. The covers will sit over the tray with the side cutouts facing outwards.
5. Hook the Plate - Limiter, Auto Feeder on the Left and Right Auto Feeder Covers using the slots on the top. The side flanges should sit between the upright bends on the Covers.
6. Push Drive Knobs inward to engage Drive Coupler. Rotate Knob Retainers over Drive Knob.

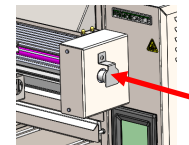
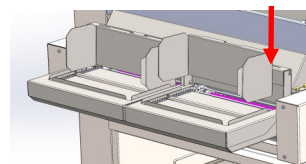
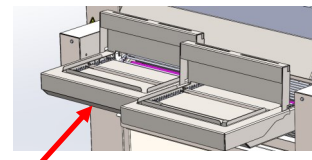
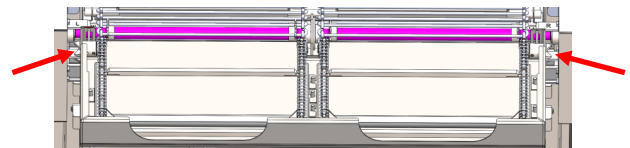
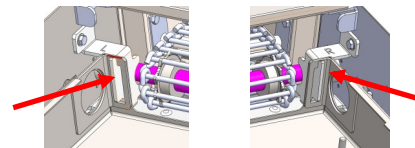
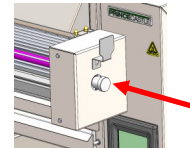

B. UNBOXING & ASSEMBLY

B.3 Assembly

- **Impedance Plate**

1. Place Plate - Impedance on top of broiler with the raised flange towards the rear.
2. Slide Plate onto broiler until the front tabs stop it.

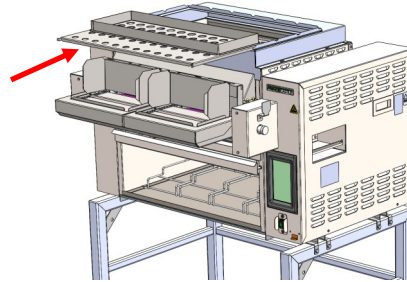

- **Rear Parts**

1. From the back of the Broiler, hook the Shield—Heat, Exit Ramp on the posts on the Left and Right Inner Walls located just under the Grill Chain in the middle. The Top Post will fit into the slot on the Shield.

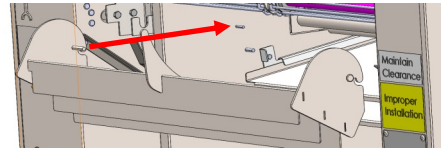

2. Hang the Shaft—Rear Scraper in the hooks on the Left and Right side under the Rear Drive Shaft.

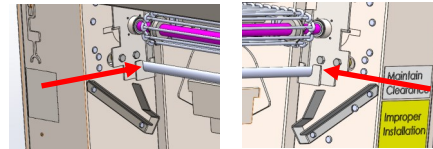

3. Place the Scraper - Rear over the Shaft previously installed above. The Scraper should go above the Shaft and below the Grill Chain. It should hang from the arm on each side and contact the Grill Chain.

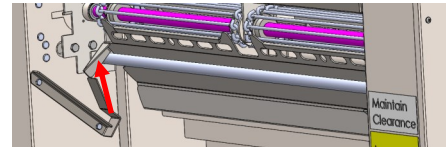

4. Hang the Cover - Exit Ramp on the upper posts at the rear of the Broiler. Allow the top bend to tuck inside the Top Cover.

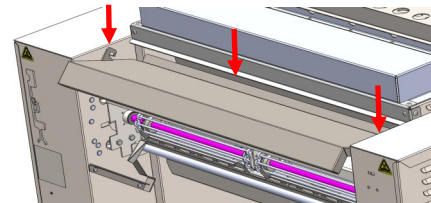

5. Slide the Ramp - Exit down the rails located on the Left and Right side of the Broiler at the rear. The Ramp is fully installed when it's side tabs are flush against the Rear Wall.

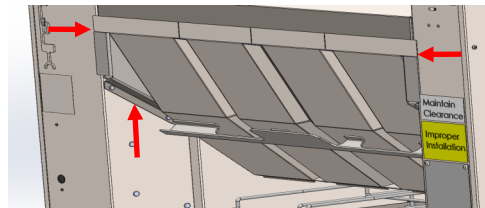

C. INSTALLATION

Recommended Installation Kit:

1000-610: Kit—Flame King Broiler Install

Includes:

- 3/4" Dia. Blue Hose (60")
- Snap Fast Quick Connect
- Full Port Valve
- 2X Swivel Max Couplers
- Wall Restraining Kit

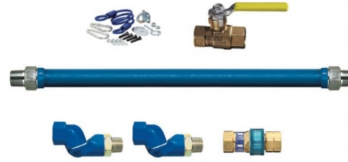

C.1 Mounting

Follow the mounting instructions if this function is not performed by the installer.

C.2 Leveling

It is extremely important that the broiler be placed on a level surface.

C.3 Hood Requirements

This appliance must be installed under a ventilation hood of adequate size. Do not obstruct the flow of combustion and ventilation air. An adequate air supply must be available for safe and proper operation.

Venting shall be in compliance with **NFPA (54) Code 10.3.5.1 & 10.3.5.2 (2002)**.

C.4 Gas Connection– 3/4" N.P.T

At rated input the gas supply should deliver a minimum pressure of at least 17.5 mbar (7" water column) at the broiler connection for natural gas. Incoming gas supply pressure must not exceed 35 mbar (14" water column).



CAUTION

SEVERE FIRE HAZARD. Do not install this broiler near combustible surfaces. Follow the recommended clearances to non-combustible surfaces to prevent a fire and safety hazard. Follow all fire and building codes.

Note: The installation of this appliance must conform with local codes, or in the absence of local codes, with the National Fuel Gas Code, ANSI Z223.1, Natural Gas Installation Code, CAN/CGA-B149.1 including:

1. The appliance and its individual shutoff valve must be disconnected from the gas supply piping system during any pressure testing of that system at test pressures in excess of 1/2 psi (3.45 kPa).
2. The appliance must be isolated from the gas supply piping system by closing its individual manual shutoff valve during any pressure testing of the gas supply piping system at test pressures equal to or less than 1/2 psi (3.45 kPa).

WARNING: This product can expose you to chemicals, which are known to the State of California to cause cancer. For more information go to www.P65Warnings.ca.gov.

C. INSTALLATION

C.5 Installing Gas Appliance Connectors and Flexible Gas Lines Correctly

For safety in the kitchen area, and to insure maximum service life, it is vitally important to correctly install connectors. The connector shall comply with the Standard for Connectors for Moveable Gas Appliances, ANSI Z21.69 or CAN/CGA-6.16 and a quick disconnect device that complies with the Standard for Quick-Disconnect Devices for use with gas fuel, ANSI Z21.41 or CAN1-6.9

In order to avoid sharp kinks or excessive bends that could have a damaging effect on the connector, it may be necessary to attach pipe elbows in order to bring the connector into its proper plane. For easy movement of the appliance, the connector should be installed with a “lazy” loop for minimum tension. Note: Gas appliances should be disconnected prior to maximum movement. (Minimal movement is possible to connect hose.)

A suitable restraint kit must be installed to limit movement of the flexible gas hose.

C.6 Clearance

Keep appliance area free from combustibles.

To facilitate disassembly and service of the unit, a minimum of 24" (610mm) should be allowed on the control panel (feed end) of the broiler.

REQUIRED AND RECOMMENDED CLEARANCES

	Minimum Clearance for installation near non-combustible walls and construction	Minimum Clearance Recommended by Prince Castle for proper disassembly and service
Back of broiler	3" (77 mm)	24" (610 mm)
Sides of broiler	3" (77 mm)	6" (153 mm)
Front of broiler	24" (610 mm)	24" (610 mm)

C.7 Electrical Connection

Power requirements are stated on the unit nameplate and must be connected accordingly. Before starting broiler, tighten all electrical connections in control box. An electrical wiring diagram can be found inside the control box.

Note: Disconnect power before servicing or cleaning.

C. INSTALLATION

C.8 Restraining Device Installation and Use

This high-strength restrainer is to be used with all moveable appliances on casters. It fully complies with American Gas Association requirements. References: Z21.69, Z83.11, and Z21.41 with current revisions. Installation is quick and positive. In Canada, device is in accordance with CAN 1-6.9-M70 Quick Disconnect Devices for use with gas fuel, and CAN 1-6.10-88 metal connectors for gas appliances. Correct length for any appliance is simply a matter of loosening two adjuster clips (1) and re-tightening. (3" to 6" shorter than appliance connector is desired length.) Restrainer is made of heavy duty steel cable with a strong scissor hook (2) at one end and an equally strong spring hook (3) at the other. Cotter pin (4) is supplied to secure the installation. For proper attachment to the broiler, use the supplied hardware to attach the device to the hole in the bottom-left rear corner plate of the broiler stand.

NOTE: If disconnection of the restraint is necessary, reconnect the restraint after the appliance has been returned to its originally-installed position.



IMPORTANT: This Restraining Device should be ordered with every connector for Movable appliances.

C.9 Pre-Operation Check

Be sure that all parts are installed in the proper location.

- Ventilation is turned on
- Broiler is plugged in
- Gas line is connected

C. INSTALLATION

C.10 Pressure Adjustment

1. Make sure the unit is turned off.
2. Unplug the quick disconnect wire from valve "HI" pin and place loose connector in a wire cover.
3. Use a 3/32" Allen key to turn the outlet pressure test tap screw one turn counter clockwise, not more than one turn.
4. Attach a tube (5/16" ID Polyethylene recommended) and manometer to the outlet pressure boss of the valve.
5. Remove brass cover from the LO outlet pressure adjustment screw.
6. Turn unit ON.
7. Read pressure value and turn regulator screw clockwise to increase pressure and counter-clockwise to decrease pressure until the correct LO value is met.
8. See the specification plate on rear of broiler for pressure settings.
9. Turn unit OFF.
10. Replace the brass cover to the LO adjustment screw.
11. Reconnect quick disconnect to the valve's "HI" pin.
12. Remove brass cover from the HI outlet pressure adjustment screw.
13. Turn unit ON.
14. Read pressure value and turn regulator screw clockwise to increase pressure and counter clockwise to decrease pressure until the correct HI value is met.
15. Replace the brass cover to the HI adjustment screw.
16. Disconnect hose from valve pressure boss.
17. Use Allen key to turn the outlet pressure test screw clockwise to stop the flow of gas.
18. Turn unit OFF.

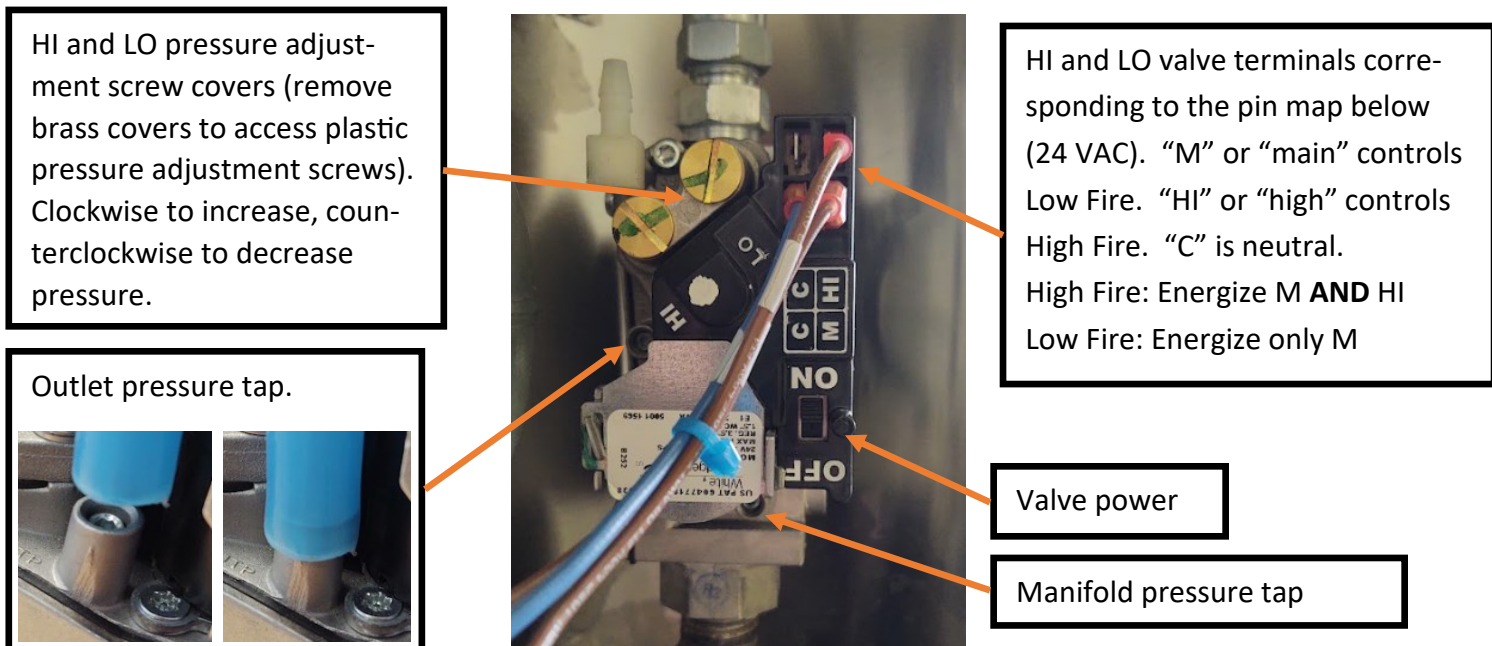

D. OPERATION

C.11 Set Point Temperature

Note: Only after the Gas Pressures have been set according to Section C.10 can proceed with setting the Set Point Temperature.

1. Turn unit ON.
2. When the HEATING UP screen appears, confirm that the Set Point Temperature (top temperature) is set to 1000° F. If it isn't, tap the Set Point Temperature (top temperature) displayed. If prompted, enter the Managers PIN # and set the temperature to 1000°F.
4. Allow the Broiler to heat up and reach a steady cook temperature. This will take approximately 40 minutes.
5. After 40 minutes, record the Current Broiler Temperature (bottom temperature).
6. Take the Current Broiler Temperature (bottom temperature) and **subtract** 40° F from it (example: 840° F - 40° F = 800° F). This will be your new Set Point Temperature (top temperature).
7. Tap the Set Point Temperature (top temperature) displayed. If prompted, enter the Managers PIN# and set the temperature to calculated value in Step 6.
8. Tap the check symbol to confirm the change. You should now see your calculated temperature as the new Set Point Temperature (top temperature).

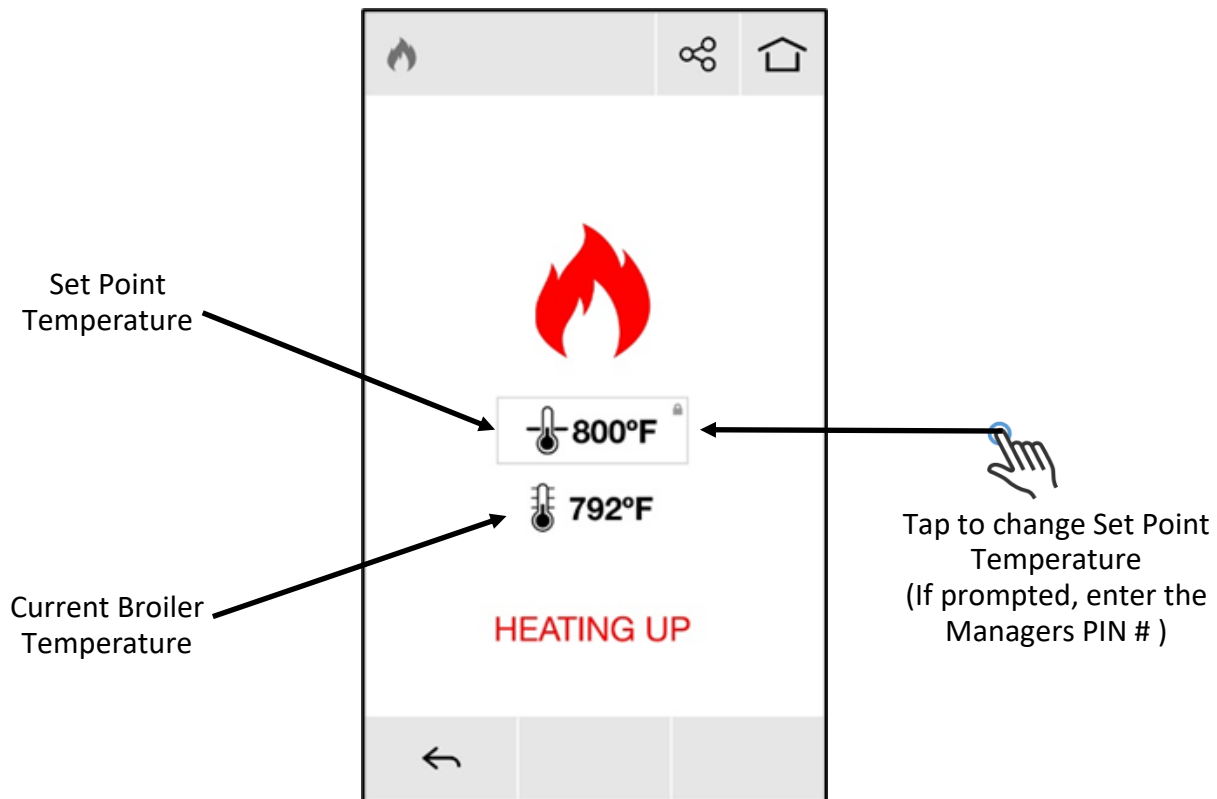

D. OPERATION

D.1 Controls and Indicators

1. Check machine is plugged into 120V outlet and main gas line is connected to broiler appliance.
2. Turn the MAIN POWER SWITCH on to start the machine.
3. On the control display window, the company logo appears with synchronizing dots for the system startup. **(Diagram 1)**



Diagram 1

4. When broiler is fully powered up, the company logo display is replaced with the HEATING UP screen that will remain until the broiler is ready to cook **(Diagram 2)**. It takes approximately 40 minutes for broiler to reach steady cook temperature from the room temperature.

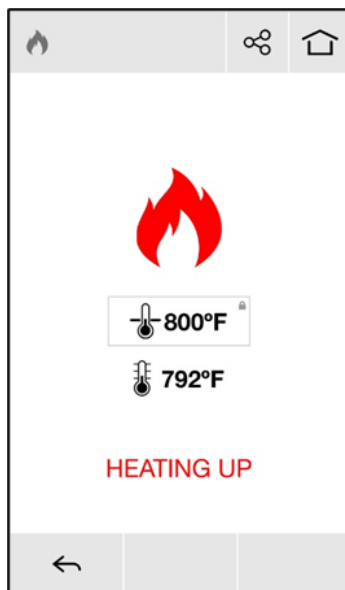
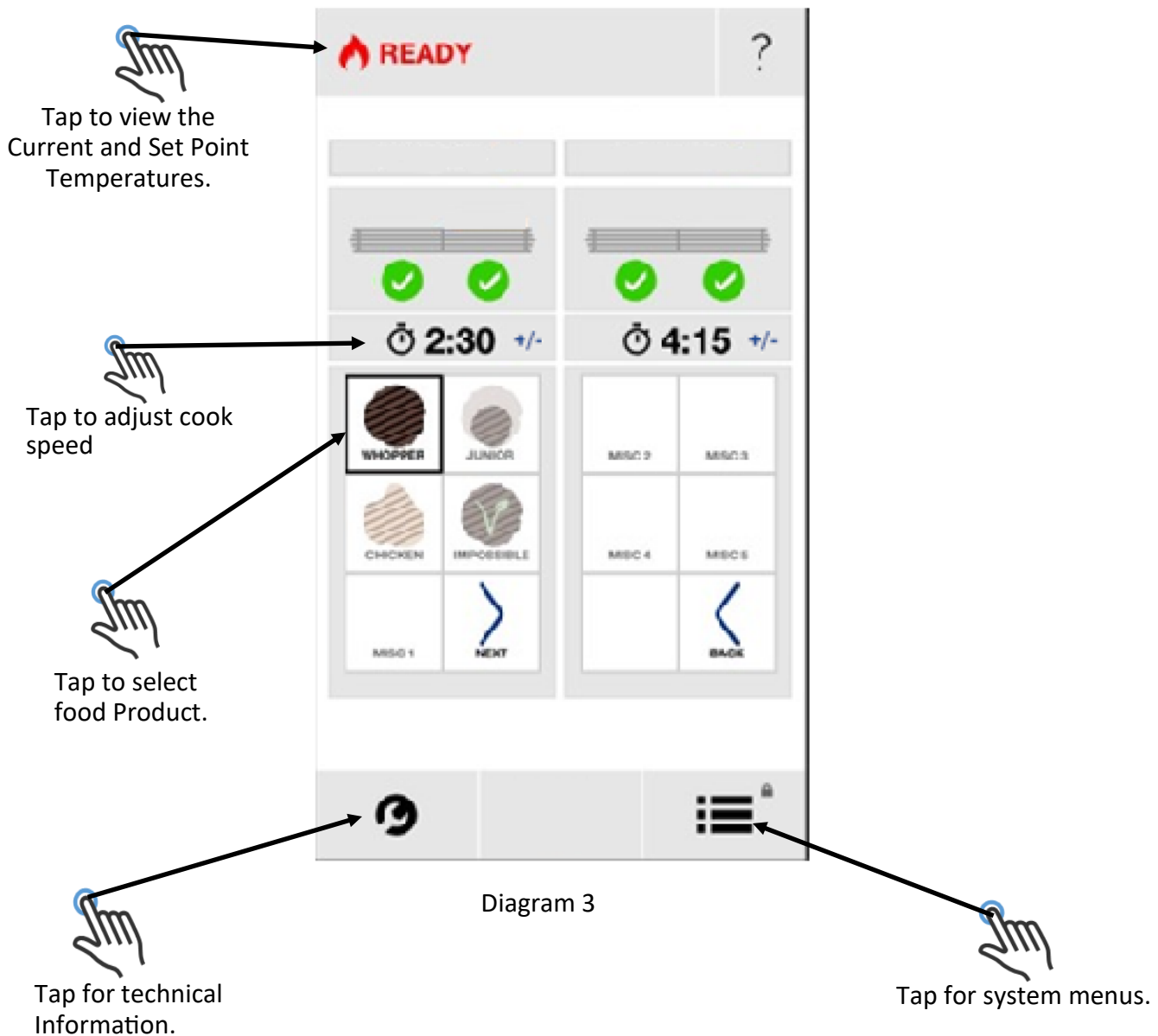

Diagram 2

D. OPERATION

5. If the main control screen is reached before the broiler is ready to cook (by tapping on the “home” button in the upper right corner), the top left corner indicates broiler HEATING UP. Once Set Point Temperature is reached, the status of the machine will change to READY. **(Diagram 3)**
6. To view Set Point Temperature and Current Temperature, from the main control screen tap the flame icon in the upper left corner.
7. Each lane of the broiler is independently controlled. The left side of the screen controls Lane 1 and the right side controls Lane 2. Each lane can cook either the same or different food product.
8. Tap and select the desired food product for LANE 1 (left) and LANE 2 (right). **(Diagram 3)**
9. If adjustment is required in the cook time, press the time indicator and adjust as necessary. Left side for Lane 1 and right side for Lane 2. **(Diagram 3)**



D. OPERATION

D.2 Product Loading

1. Each lane has its own independent Auto Feeder. The Auto Feeder is designed to run at the same speed as that lanes grill chain.
2. Each lane has two loading positions, left and right. **(Diagram 4)**
3. Allow the pusher bar to pass by and stack frozen product directly on Auto Feeder sheet metal. Two stacks of product per lane and no higher than the limiter plates. **(Diagram 5)**

Note: Be sure to separate frozen product before stacking. Products that are frozen together have the risk of causing improper cooking or damage to the broiler.

4. As product is fed into the broiler, additional product can be placed on the stack if required.

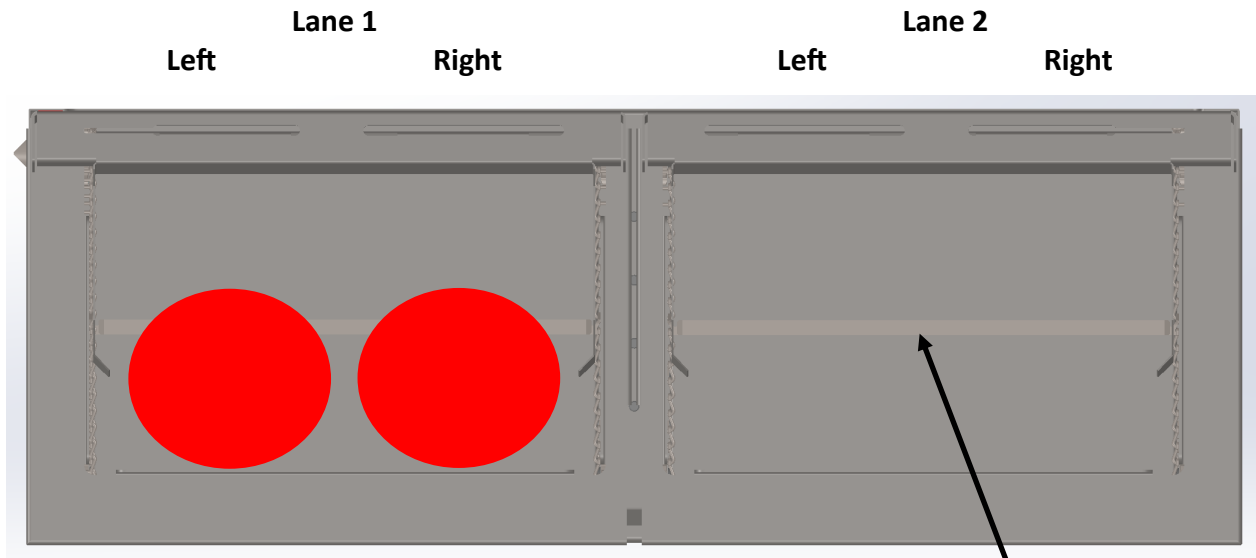

Diagram 4

Pusher Bar

Maximum height of product stack.

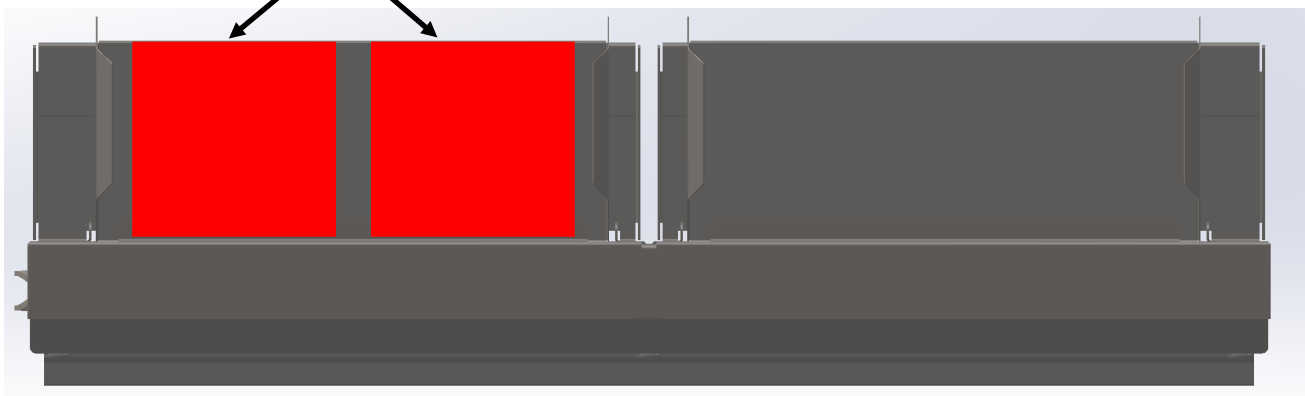

Diagram 5

C. OPERATION (CONTINUED)

D.3 Shutdown Procedures

EMERGENCY SHUTDOWN

1. Turn off the **MAIN POWER SWITCH**.
2. Close the **MAIN GAS VALVE**. Valve is closed when it is perpendicular to pipe.
3. **Wait until broiler cools down before cleaning or servicing.**

Your Prince Castle Flame King Broiler is designed to automatically stop gas flow to the broiler in the event of power failure, gas pressure loss or any other related incident. No attempt to operate this appliance should be made in the event of a power failure.

D. PARTS IDENTIFICATION

FEED END VIEW

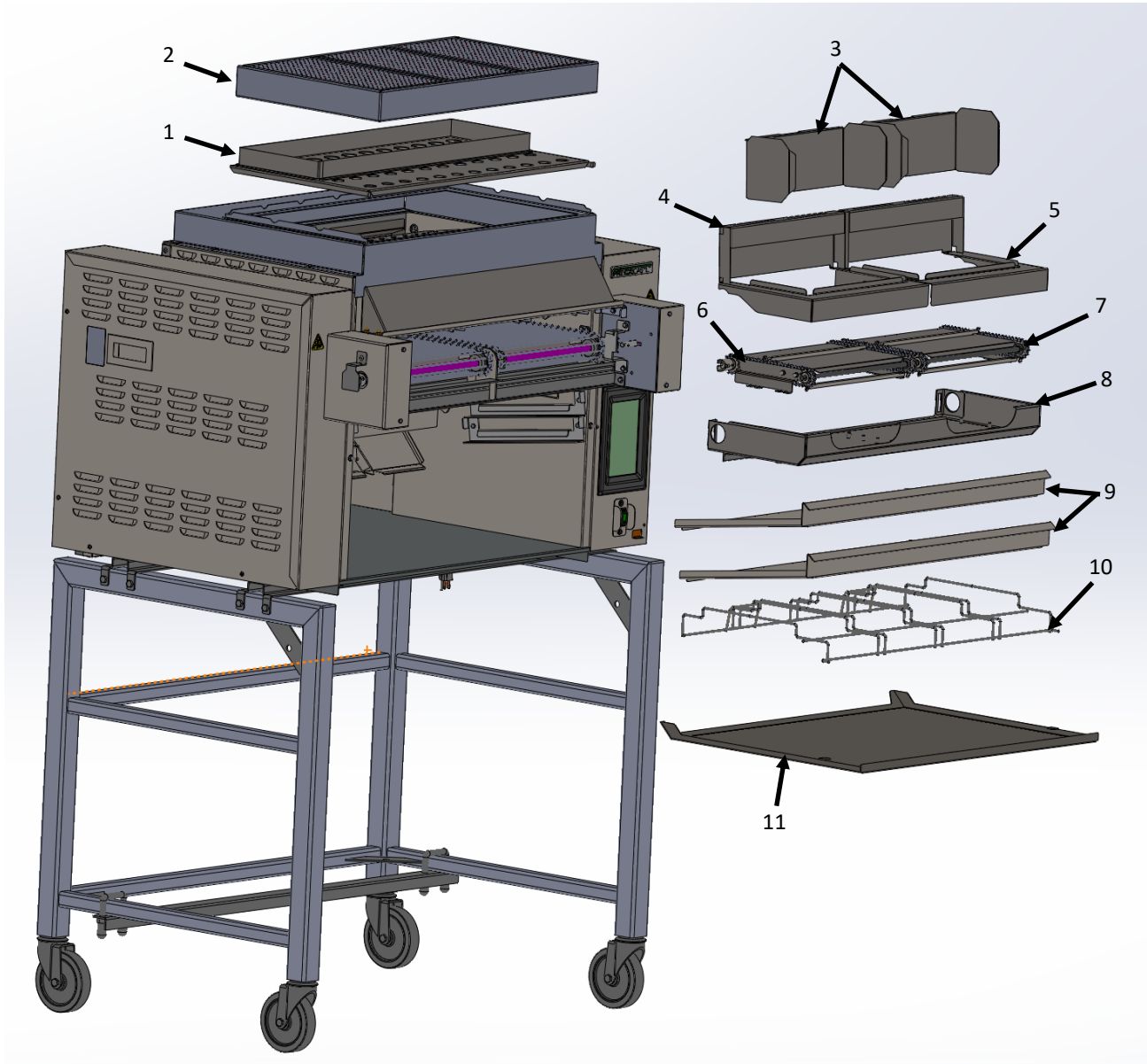

Item #	Description	Item #	Description
1	PLATE - IMPEDANCE	7	CARTRIDGE -RIGHT, AUTO FEEDER
2	CATALYST (IF EQUIPPED)	8	TRAY - MAIN, AUTO FEEDER
3	PLATE - LIMITER, AUTO FEEDER	9	SHIELD - HEAT/GREASE
4	COVER - LEFT, AUTO FEEDER	10	RACK - HOLDING BINS
5	COVER - RIGHT, AUTO FEEDER	11	TRAY - LANDING ZONE
6	CARTRIDGE - LEFT, AUTO FEEDER		

D. PARTS IDENTIFICATION

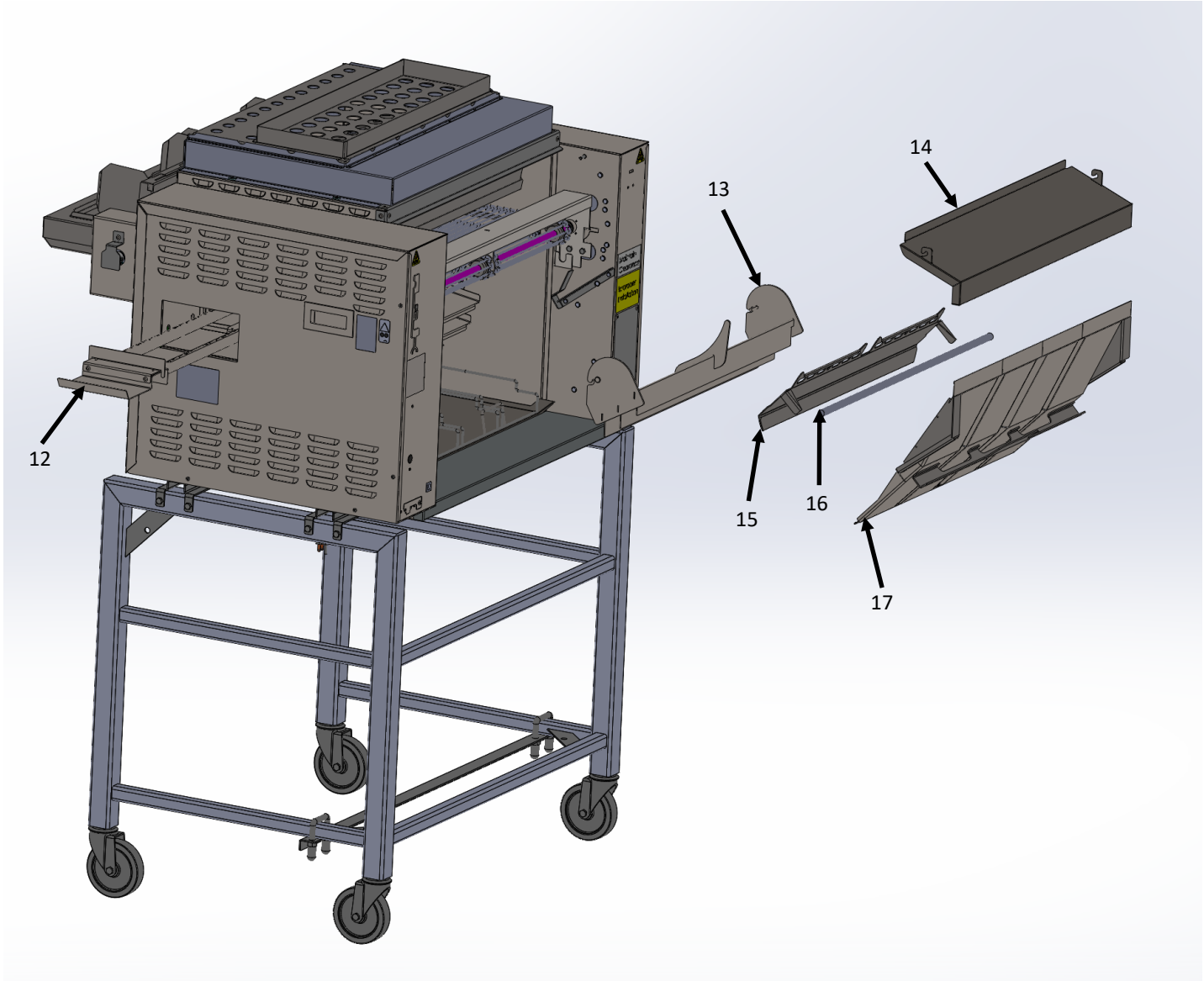

Item #	Description
12	BURNERS - TUBE, NG
13	SHIELD -HEAT, EXIT RAMP
14	COVER - UPPER EXIT
15	SCRAPER - REAR
16	SHAFT—REAR SCRAPER
17	RAMP - EXIT

E. CLEANING

Turn broiler off and close the main gas valve. Disconnect the power supply to the broiler before cleaning or servicing. If this broiler is connected using a restraint and disconnection of the restraint is necessary for cleaning or moving the broiler, the restraint must be reconnected after the broiler has been returned to its originally-installed position. Allow to cool for 30 minutes prior to cleaning/disassembly. Leave the ventilation system on during cooling. Use only approved cleaning, degreasing, and sanitizing solutions.



WARNING

LEAVE THE VENTILATION HOOD ON DURING COOLING. FAILURE TO DO SO COULD POSE A FIRE SAFETY HAZARD.



CAUTION

Follow the disassembly and reassembly steps to ensure proper operation of the broiler. Failure to do so may result in operational problems.



WARNING

BROILER PARTS ARE HOT. DO NOT ATTEMPT TO DISASSEMBLE THE BROILER UNTIL IT IS FULLY COOL. FAILURE TO FOLLOW THIS INSTRUCTION MAY RESULT IN SEVERE INJURY.

ALL PARTS ARE CLEANED ON A DAILY BASES UNLESS OTHERWISE NOTED

Follow the steps for proper disassembly. Reverse the order for reassembly.

How to read the cleaning section

Name of the part to be cleaned.

HEAT VENT

The location of the part.

Feed End

Tools needed to clean the part.



Tools:



3 COMPARTMENT SINK



SCRUB PAD

How to remove and clean the parts.



Instructions:

1. Pull each heat vent out slightly from the bottom, then lift off.
2. Wash, rinse, and sanitize in the 3-compartment sink.

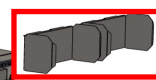
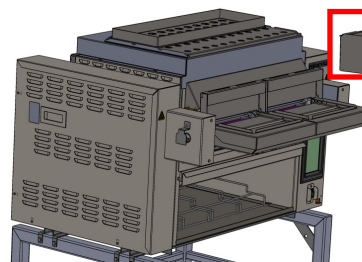

Picture of the part to be removed and cleaned.

When to clean the part.



Clean:

Once daily

E. CLEANING AND ASSEMBLY

Cleaning the Broiler

Tools Needed:



Instructions:

1. Allow the broiler to run free of product for 10 minutes before turning it off. This allows any residue to burn off the chains.
2. Shut the broiler off and let it cool for **30** minutes before disassembly and cleaning.
3. Close the main gas valve and unplug the broiler before cleaning.
4. Always leave the ventilation hood on during the cool down period.
5. Use only approved cleaning solutions.
6. Allow parts to air dry after cleaning.

Important Symbols:



This “Stop” sign shows a step in the procedure that must be followed exactly or personal safety could be affected.



This warning symbol shows a step in the procedure that must be followed exactly or broiler performance could be affected.



This “puzzle” symbol shows a step in the reassembly procedure that must be followed.

E. CLEANING (EVERY FOUR HOURS)

BURGER LIMITER



Tools:

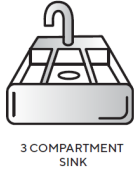

Instructions:



1. Pull the Burger Limiter out slightly from the bottom, then lift off.
2. Wash, rinse, and sanitize in the 3-compartment sink



Clean:
Every four hours.



REASSEMBLY: Hook Burger Limiter on Feeder Cover, ensure it sits between Feeder Cover rails.

Feed End

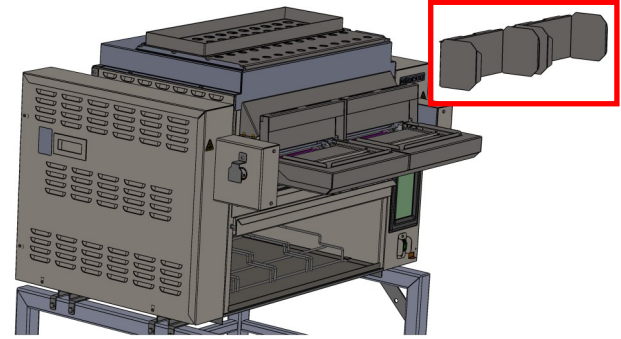

RH & LH AUTO-FEEDER COVERS



Tools:

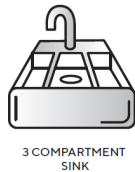

Instructions:



1. Slide the feeder cover towards you until it comes off.
2. Wash, rinse, and sanitize in the 3-compartment sink



Clean:
Every four hours



REASSEMBLY: Slide the feeder cover back into place until it is securely in position.

Feed End

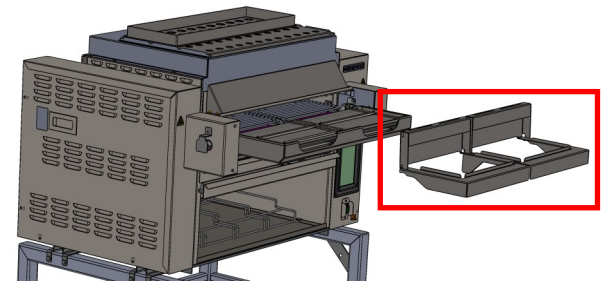

E. CLEANING (EVERY FOUR HOURS)

AUTO-FEEDER CONVEYOR SET



Tools:

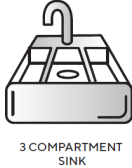

Instructions:

1. Rotate pin retainers and pull release pin outward.
2. Lift push bar and wire belt feeder bases up and off.
3. Wash, rinse, and sanitize in the 3-compartment sink.



Clean:

Every four hours



DO NOT lift the feeder base by the feeder bar or the chains. This will damage the feeder base.



REASSEMBLY: Place feeder base back in position and push in release pin. Rotate pin retainers in initial position.

Feed End

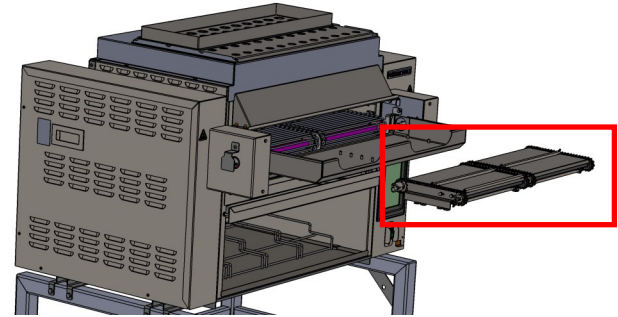

AUTO-FEEDER TRAY



Tools:

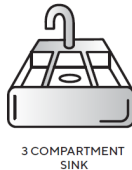

Instructions:

1. Lift and remove tray from auto-feeder hooks.
2. Wash, rinse, and sanitize in the 3-compartment sink.



Clean:

Once daily.



REASSEMBLY: Place tray back on auto-feeder hooks.

Feed End

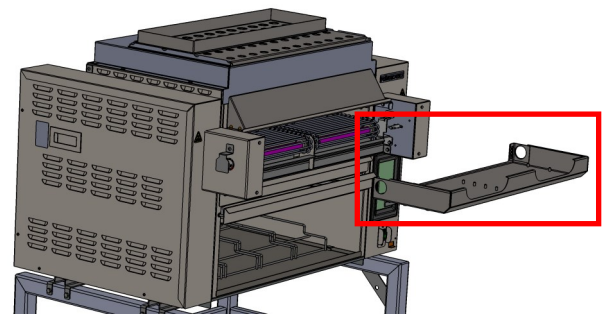

E. CLEANING (DAILY)

FRONT GREASE PANEL AND HEAT SHIELD



Tools:



3 COMPARTMENT SINK



DEGREASER



SCRUB PAD



HEAT RESISTANT GLOVES

Feed End

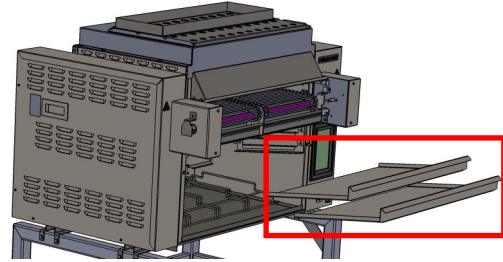

Instructions:

1. Slide out lower heat pan towards you.
2. Take to sink area and spray with degreaser.
3. Wash with a scrub pad, rinse, and sanitize in the 3-compartment sink.
4. Slide out upper grease pan towards you.
5. Take to sink area and spray with degreaser.
6. Wash with a scrub pad, rinse, and sanitize in the 3-compartment sink.



Clean:

Once daily.



REASSEMBLY: Slide warming pan shield back in and ensure it is in position. Slide front grease pan back in and ensure it is in position.

E. CLEANING (DAILY)

DISPLAY



Tools:



WATER



TOWEL

CAUTION

Use warm water. Using harsh cleaners or degreasers may cause damage to the display screen or assembly

Display

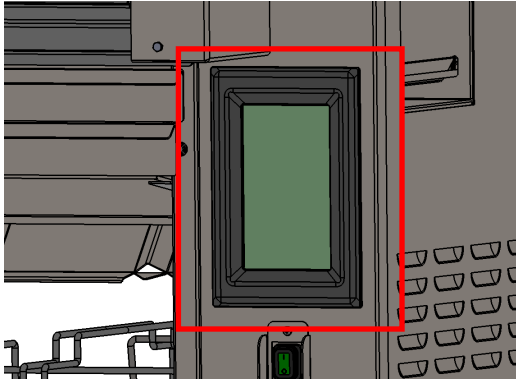

Instructions:

1. Spray water into towel
2. Wipe down the display screen until clean



Clean:

Once daily.

E. CLEANING (DAILY)

CATALYST (IF EQUIPPED)



Tools:

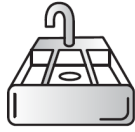

3 COMPARTMENT SINK



HEAT RESISTANT GLOVES

Catalyst

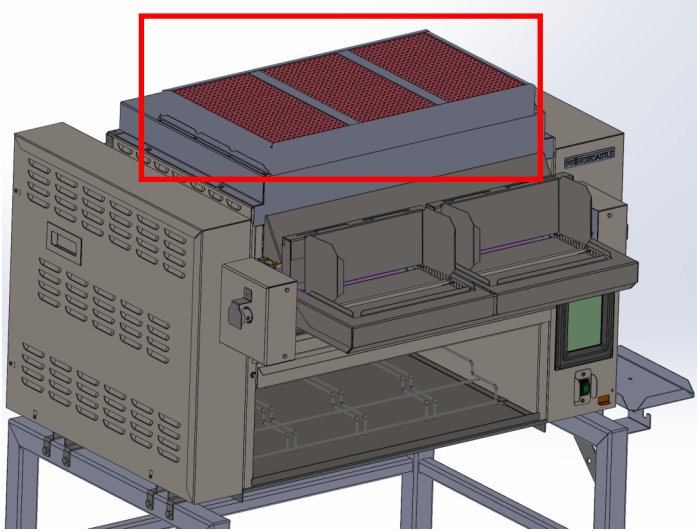

BROILER PARTS ARE HOT. DO NOT ATTEMPT TO DISASSEMBLE THE BROILER UNTIL IT IS FULLY COOL. FAILURE TO FOLLOW THIS INSTRUCTION MAY RESULT IN SEVERE INJURY.



Instructions:

1. Lift Catalyst up and off the unit top.
2. **SOAK IN WARM WATER FOR 1 HOUR. RINSE WITH WATER ONLY. NEVER USE ANY CHEMICALS ON THE CATALYST OR DAMAGE MAY OCCUR!**
3. Lay flat to drain water and let air dry overnight.
4. Make sure catalyst is completely dry before installing back onto the unit



Clean:

Once daily.

E. CLEANING (DAILY)

LANDING ZONE TRAY AND WIRE FORM



Tools:

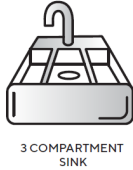

3 COMPARTMENT SINK



DEGREASER



HEAT RESISTANT GLOVES



SCRUB PAD

Feed End

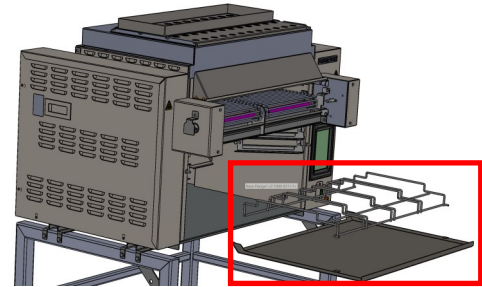

Instructions:

1. Slide component out.
2. Take to sink area and spray with degreaser.
3. Wash with a scrub pad, rinse, and sanitize in the 3-compartment sink.



Clean:

Once daily.



REASSEMBLY: Slide component back in position and ensure it is secured in place.

EXIT RAMP AND REAR SCRAPER



Tools:

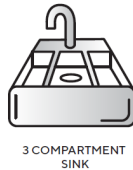

3 COMPARTMENT SINK



DEGREASER



HEAT RESISTANT GLOVES



SCRUB PAD

Back End

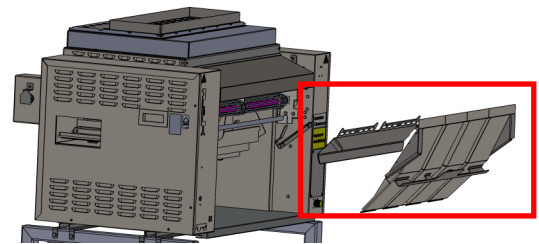

Instructions:

1. Slide component out.
2. Take to sink area and spray with degreaser.
3. Wash with a scrub pad, rinse, and sanitize in the 3-compartment sink.



Clean:

Once daily.



REASSEMBLY: Slide component back in position and ensure it is secured in place.

E. CLEANING (DAILY)

EXIT RAMP HEAT SHIELD



Tools:



3 COMPARTMENT SINK



DEGREASER



HEAT RESISTANT GLOVES



SCRUB PAD

Back End

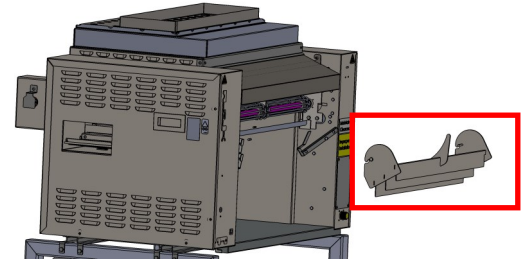

Instructions:

1. Un-hook shield from top pin and remove.
2. Take to sink area and spray with degreaser.
3. Wash with a scrub pad, rinse, and sanitize in the 3-compartment sink.



Clean:

Once daily.



REASSEMBLY: Hook shield on top pin. Allow it to rotate downward against bottom pin and ensure it is secured in place.

E. CLEANING (DAILY)

PARTS TO BE WIPED DAILY

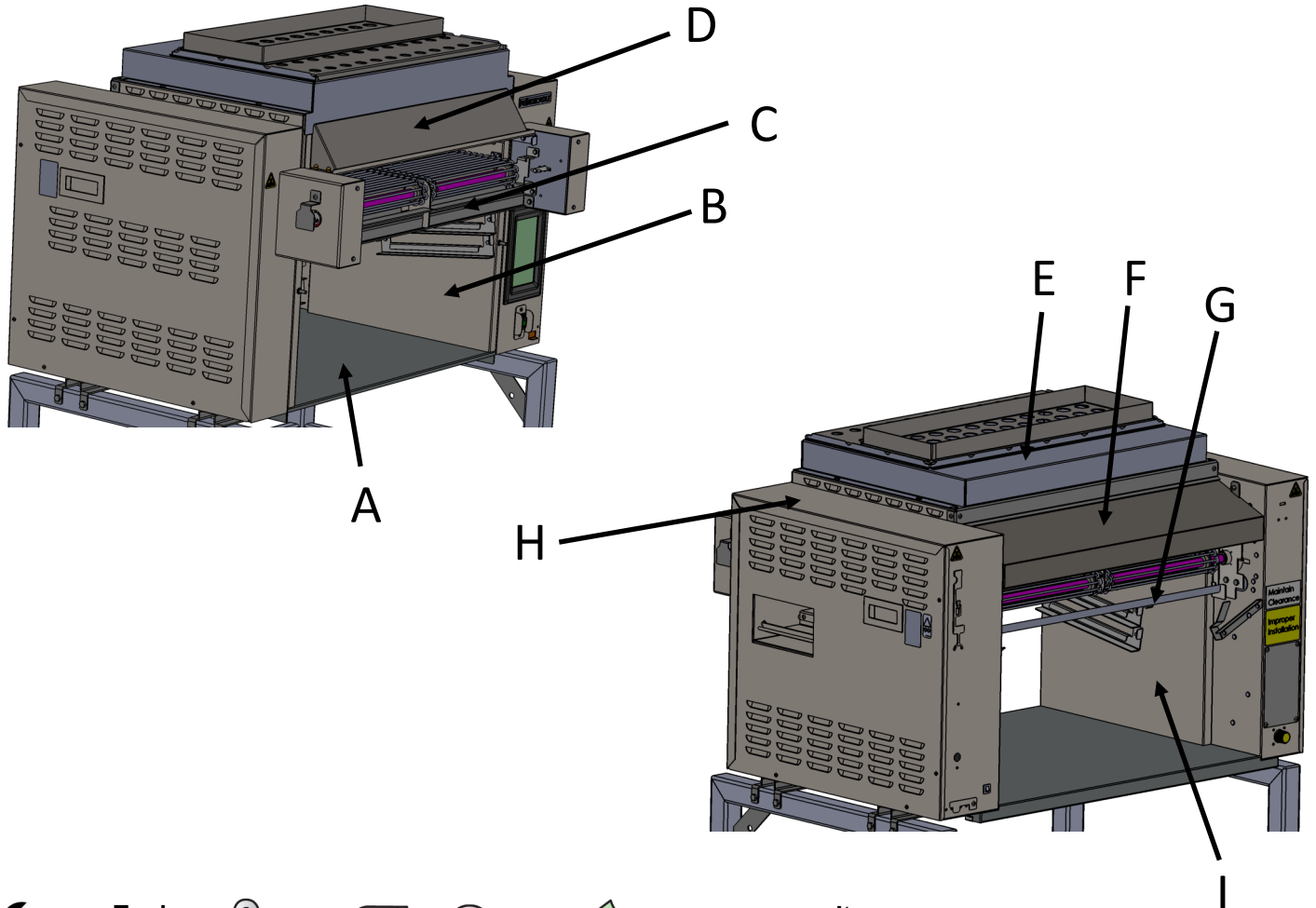

Tools:

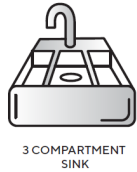

Instructions:



1. Wipe down located areas and spray with degreaser.
2. Scrub clean and rinse with a clean wet rag.



Clean:

Once daily.

Items:

- A) Base Plate
- B) Right Tower
- C) Crumb Tray (Use provided tool)
- D) Front Cover
- E) Plenum
- F) Rear Cover
- G) Rear Scraper Shaft
- H) Top of Towers
- I) Left Tower

E. CLEANING (MONTHLY)

PARTS TO BE WASHED ONCE MONTHLY

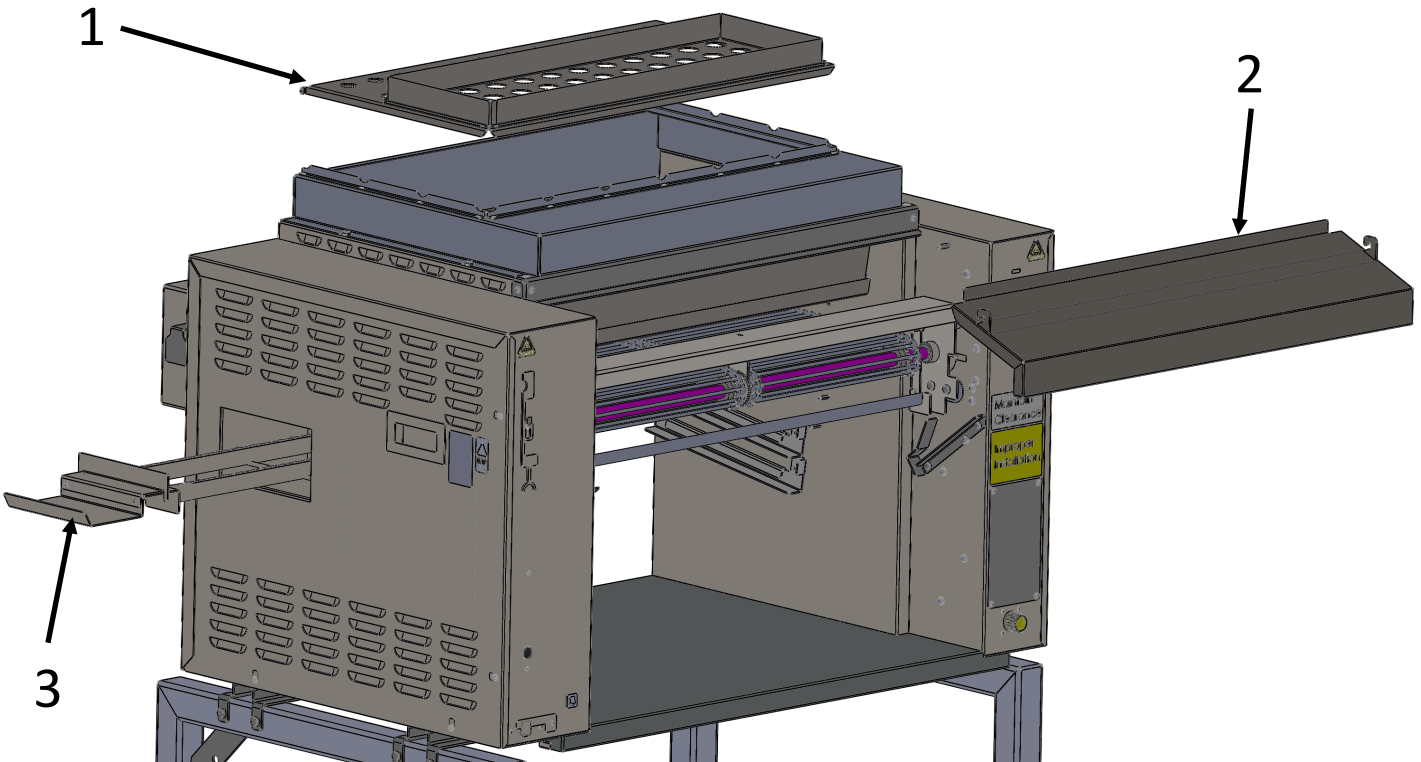

Tools:

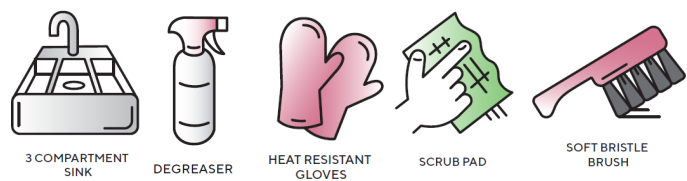

Items:

- 1. Impedance Plate
- 2. Rear Cover
- 3. Tube Burner Assembly



Instructions:

- 1. Remove component.
- 2. Take to sink area and spray with degreaser.
- 3. Wash with a scrub pad, rinse, and sanitize in the 3-compartment sink.



Clean:

Once monthly.

F. TROUBLESHOOTING

Always verify that the broiler is properly assembled, the hood is on, the gas valve is open, and the broiler is plugged in.

ID #	Problem	Indicators	Store Manager Checks	Technician Checks
1	Power switch is ON, burners are NOT lit , display is black, and the main conveyors are not moving		Broiler is plugged in Circuit breaker on wall panel is ON and not tripped	The power switch is functional and all incoming power line connections are secured
2	Power switch is ON, burners are NOT lit , but the display and conveyors are functional	Display: Red screen with "BURNER DID NOT LIGHT" text Display: Yellow triangle at the top right of the home screen with either E7, E8, E9, or E18 errors. Click on the error for additional details.	Ventilation hood is ON Gas line is properly connected and the gas valve is ON Bottom burner is pushed all the way in (no part of the handle should protrude passed the side cover) Bottom burner is clean and dry	Flame sensors are clean Flame sensors are not touching chassis when the broiler is hot Orifices are not plugged Valve on-board power switches are ON Valve pressures are set correctly Relay indicators lights turn on after a power cycle
3	Power switch is ON, burners are lit , and either the display is black or the main conveyors are not moving <i>Note: With the burners lit and conveyors moving, the broiler can cook. Upon restarting the unit, both conveyors default to Whopper.</i>	Display (if functional): Yellow triangle at the top right of the home screen with either E1 or E2 errors. Click on the error for additional details.	Turn the broiler off and on again The broiler's circuit breaker located behind the right tower is not tripped	The connections are secured on both ends of the wire harnesses connected to the control board and display The 5 VDC and 24 VDC power supplies are outputting the correct voltage The main control board has various indicator lights visible across the board
4	Broiler is status is continuously showing "HEATING UP" instead of "READY" <i>Note: With the lower burner and at least one upper burner lit, the broiler is functional after 45 minutes of heating up, even when the status still shows "HEATING UP". Perform a cookout test, adjust cook times to meet temperatures, and continue normal operation until issue is resolved.</i>	Display: Yellow triangle at the top right of the home screen with either E3, E4, E5, E6, or E18 errors. Click on errors for additional details.	See #2	See #2 Without cooking occurring, navigate to the "Cook Temperature" screen in the DEBUG menu and verify: 1. All four thermocouples values are updating. Move the thermocouples wires away from nearby power lines if so. 2. None of the thermocouples values are negative or abnormally low (200+ °F lower than the other values). Reconnect the problematic thermocouple and make sure there it is not open nor short circuited.
5	Burgers are failing to discharge		The rear scraper is installed and thoroughly cleaned The heat shield is installed The burger slide is cleaned	
6	Auto Feeder is not turning		The Auto Feeder is installed correctly and the clutch knob is pushed inward The broiler's circuit breaker located behind the right tower is not tripped <i>See #1 and #3</i>	The Auto Feeder roller chain is engaging the main conveyor sprocket and the clutch sprocket <i>See #1 and #3</i>
7	Burgers under or over cooked.		Increase the cook time to increase cookout temperature, decrease cook time to decrease cookout temperature All burners are lit Ventilation - make sure there isn't excessive exhaust or air vent blowing on the broiler	
8	Excessive flaming in broiler.		Thoroughly clean the grease tray Clean the catalyst if equipped. Check that all removable components are installed	
9	Too much smoke or heat in the kitchen		Check that the ventilation hood is ON and working Check that the broiler is properly positioned under the ventilation hood Check condition of catalyst if equipped	

G. ERROR CODES

Code #	Description	Symptom
1	ERROR_CONVEYOR1_EITHER_STUCK_OR_NOT_WORKING	Conveyor 1 stuck or not working
2	ERROR_CONVEYOR2_EITHER_STUCK_OR_NOT_WORKING	Conveyor 2 stuck or not working
3	ERROR_TEMPERATURE_SENSOR1_ERROR	Temperature Sensor 1 either open or short
4	ERROR_TEMPERATURE_SENSOR2_ERROR	Temperature Sensor 2 either open or short
5	ERROR_TEMPERATURE_SENSOR3_ERROR	Temperature Sensor 3 either open or short
6	ERROR_TEMPERATURE_SENSOR4_ERROR	Temperature Sensor 4 either open or short
7	ERROR_IGNITION_MODULE1_SHUT_DOWN	Front Upper Burner Fault
8	ERROR_IGNITION_MODULE2_SHUT_DOWN	Bottom Burner Fault
9	ERROR_IGNITION_MODULE3_SHUT_DOWN	Rear Upper Burner Fault
12	ERROR_USB_FAIL	USB failure
13	ERROR_CPU_UTILIZATION	High CPU utilization
14	ERROR_EEPROM_CORRUPT	EEPROM is corrupt
15	ERROR_MENUTUN_CORRUPT	Menu or tunable is corrupt
16	ERROR_ADC_CHANNEL_INIT_FAIL	Analog to digital converter initialization failed
17	ERROR_TIM_INIT_FAIL	Timer initialization failed
18	ERROR_FLAME_CONTROL	Flame Control Failure - unable to maintain desired temperature
19	ERROR_GENERAL_SYSTEM_FAULT	General Fault - Check the system

H. PARTS LIST

ELECTRICAL COMPONENTS RIGHT TOWER

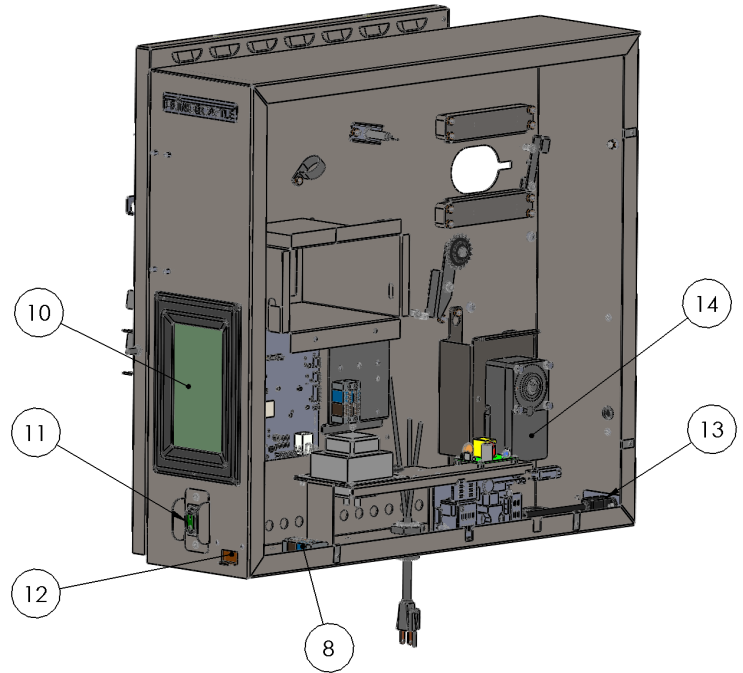
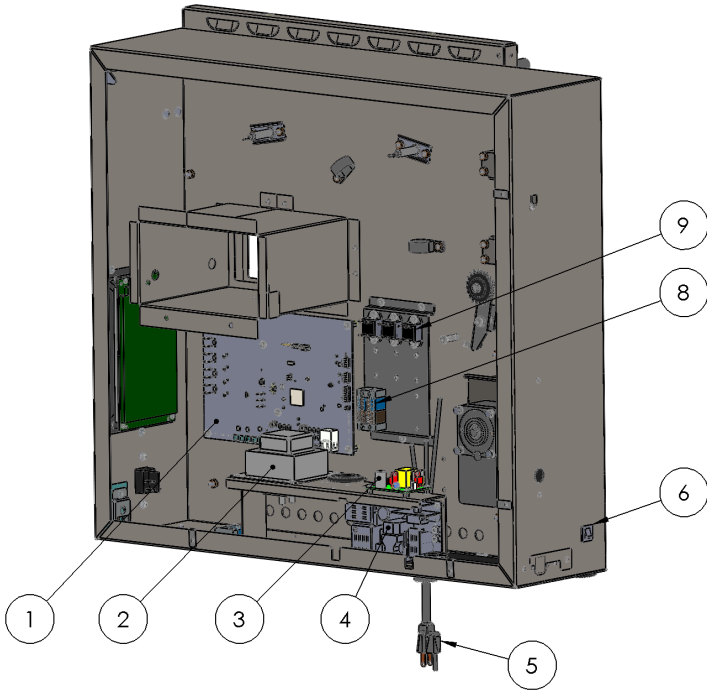

ITEM #	PART #	DESCRIPTION
1	7500-030	PCB—BROILER, MAIN
2	1000-803	POWER—TRANSFORMER, 24VAC
3	1000-801	POWER—SUPPLY, 5VDC
4	1000-802	POWER—SUPPLY, 24VDC
5	72-703	CORD—POWER, 16/3
6	1000-717	FUSE—CIRCUIT BREAKER, 4 AMP
7	-	-
8	1000-227	BLOCK—TERMINAL ASM
9	353-313	RELAY—IRT, 4-8VDC, 20A
10	1000-882S	DISPLAY—SCREEN W/BEZEL & GAS-KETS
11	78-184s	SWITCH, ROCKER, DPST, 16A
12	44368	CONNECTOR—USB ASM
13	95-2052	CONNECTOR—ETHERNET
14	1000-855S	MOTOR—STEPPER, 24VDC W/BRKT
NA	95-4430	CBL BROILER EMB DISPLAY
NA	95-4431	CBL, EXT, MOTOR, ORIENTAL

ITEM #	PART #	DESCRIPTION
NA	95-4409	IGNITION HV SHORT (N51537)
NA	95-4410	IGNITION HV LONG (N51538)
NA	95-4411	IGNITION SENSE 2 (N51539)
NA	95-4412	IGNITION SENSE 1+3 (N51540)
NA	95-4413	NEUTRAL BARRIER TO GND (N51541)
NA	95-4414	IGNITION TO GAS VALVE (N51542)
NA	95-4415	PCBA 24VAC TO IGNITION (N51543)
NA	95-4416	24VAC TO PCBA (N51544)
NA	95-4417	SSR 6,7,8 TO GAS HI (N51545)
NA	95-4418	BARRIER TO GAS SSR (N51546)
NA	95-4419	NEUTRAL BARRIER TO BARRIER (N51547)
NA	95-4420	PCB TO IGNITION/GAS TO SSR (N51548)
NA	95-4422	PS 5VDC AC SIDE (N51550)
NA	95-4423	PS 24VDC AC SIDE (N51551)
NA	95-4424	PS 24/5VDC DC SIDE (N51552)
NA	95-4426	SWITCH S1 (N51554)
NA	95-4428	IOT MODULE TO BROILER HARNESS (N51556)
NA	95-4429	CBL BROILER EMB GAS VALVE GRN (N51602)

H. PARTS LIST (CONTINUED)

BURNER IGNITION AND CONTROL

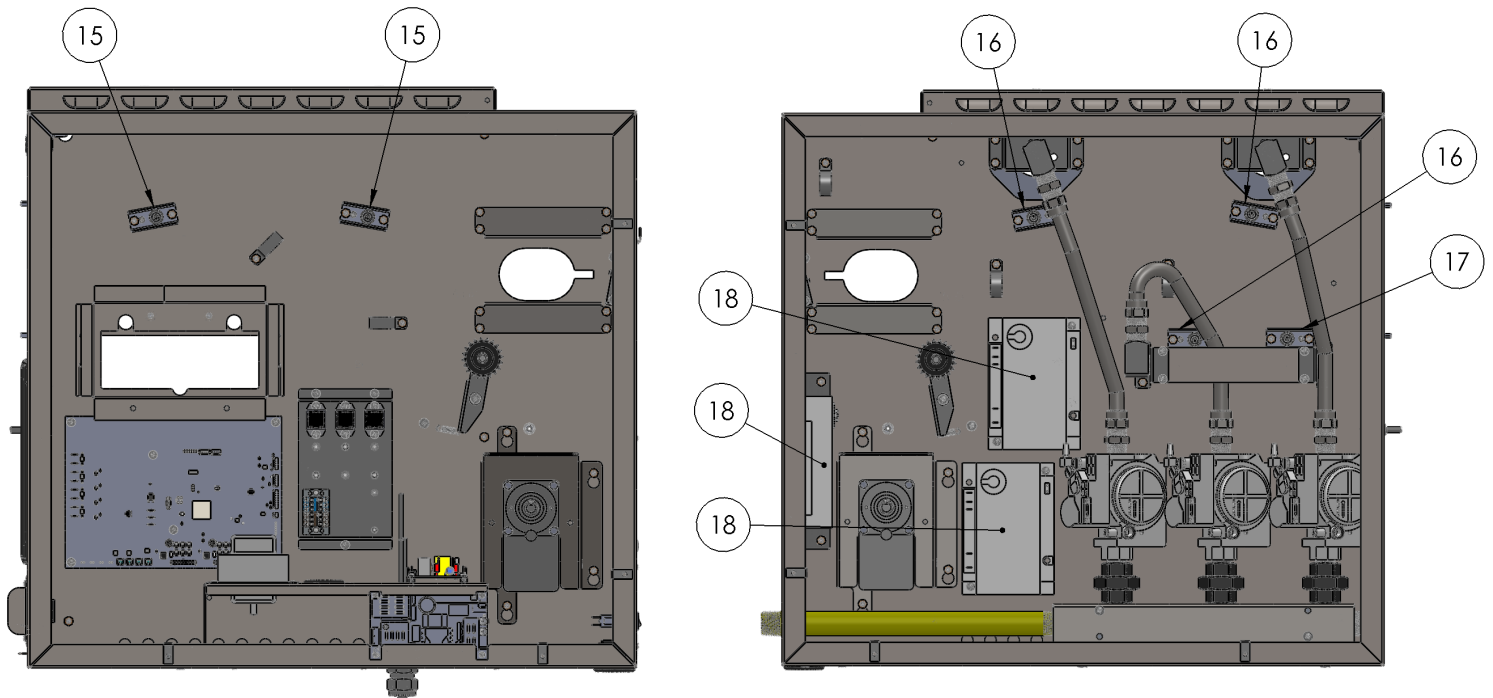

ITEM #	PART #	DESCRIPTION
15	1000-814	SENSOR—FLAME, IR BURNER
16	1000-146	IGNITOR—SPARK. IR & TUBE
17	1000-745	SENSOR—FLAME, TUBE BURNER
18	1000-818	MODULE—IGNITION, FENWAL

H. PARTS LIST (CONTINUED)

GAS COMPONENTS

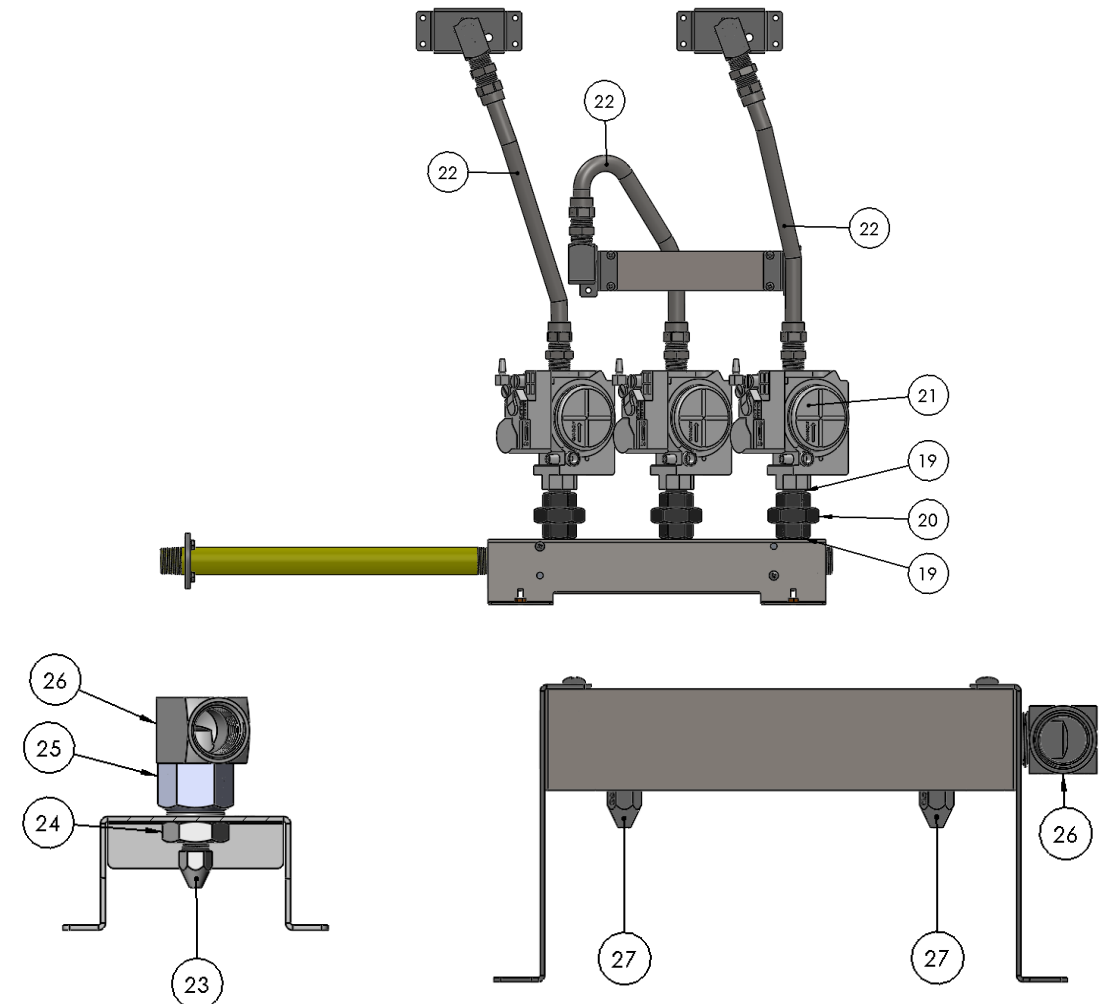

IR BURNER MANIFOLD

TUBE BURNER MANIFOLD

ITEM #	PART #	DESCRIPTION
19	1000-739	FITTING—1/2" NPT, FULLY THREADED
20	1000-738	FITTING—SWIVEL, 1/2" NPT
21	1000-824	VALVE—DUAL STAGE, WHITE RODGERS
22	1000-993	TUBE—FLEX, 1/2" NPT, 1FT, SS
23	1000-981	ORIFICE—#48, IR BURNERS
24	1000-980	NUT—JAM, 9/16"-18, 5/16" THK
25	1000-970	FITTING—BULKHEAD, 1/2" NPT X 1/8" NPT
26	1000-716	FITTING—ELBOW, M TO F, 1/2" NPT, BRASS
27	1000-711	ORIFICE—#38, TUBE BURNER
*	1000-567	KIT HIGH ALTITUDE (ORIFICES—#44)

* NOT SHOWN

H. PARTS LIST (CONTINUED)

AUTO FEEDER COMPONENTS

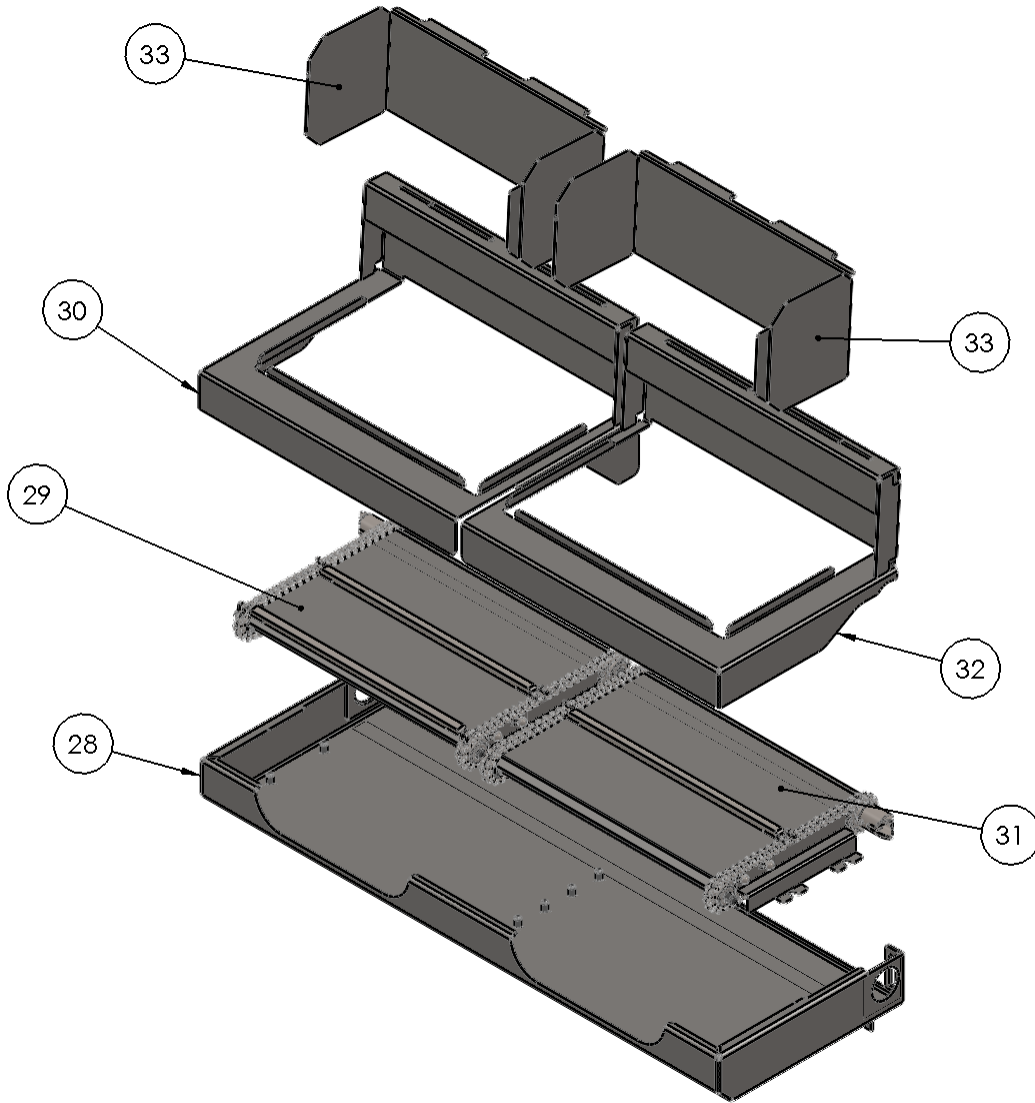

ITEM #	PART #	DESCRIPTION
28	1000-305	TRAY—AUTO FEEDER BASE
29	1000-310	CARTRIDGE—AUTO FEEDER, LEFT
30	1000-302	COVER—AUTO FEEDER, LEFT
31	1000-325	CARTRIDGE—AUTO FEEDER, RIGHT
32	1000-303	COVER—AUTO FEEDER, RIGHT
33	1000-301	PLATE—LIMITER, AUTO FEEDER

H. PARTS LIST (CONTINUED)

TUBE/IR BURNER COMPONENTS

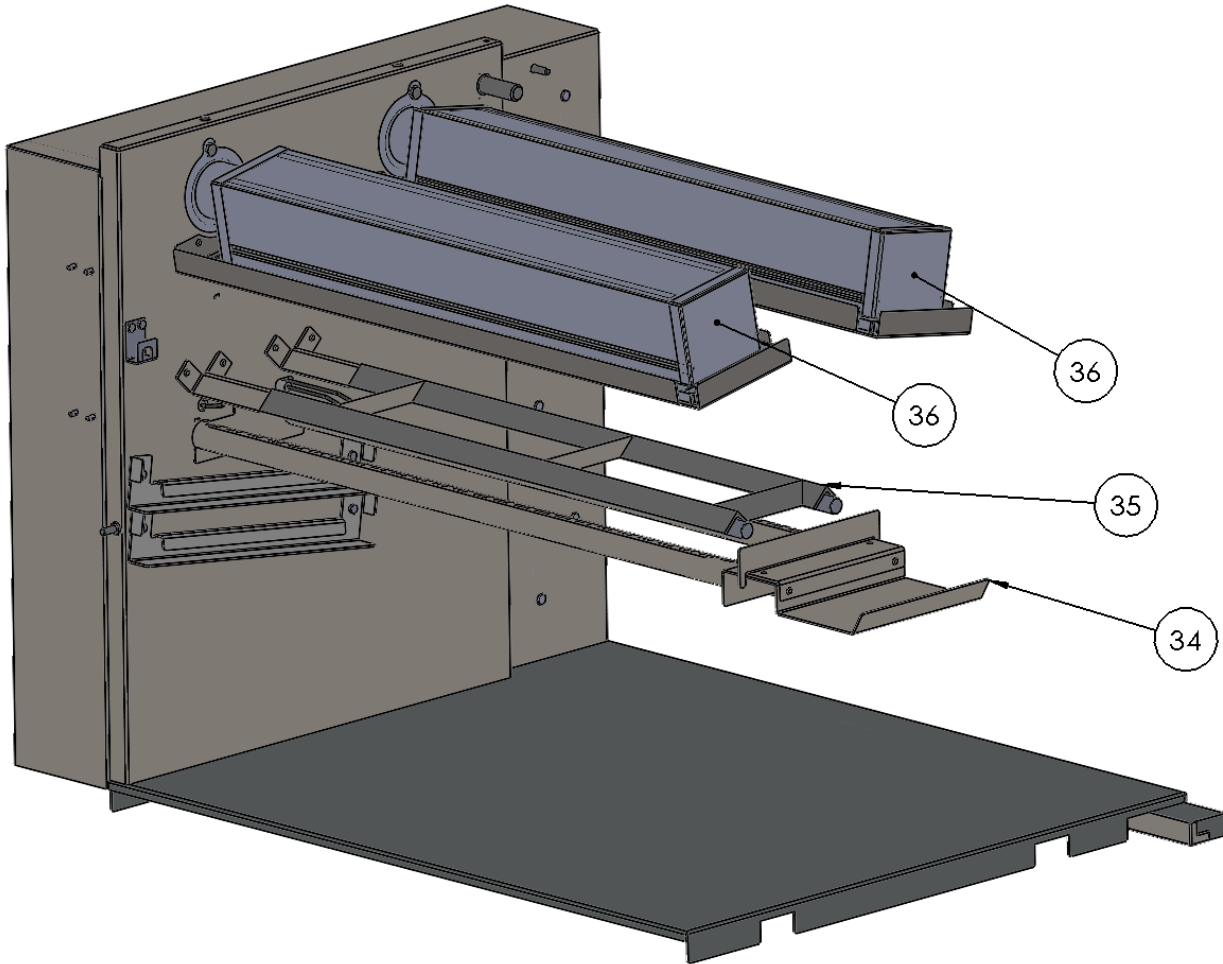

ITEM #	PART #	DESCRIPTION
34	1000-955	BURNER—TUBE ASM
35	1000-920	SHIELD—TUBE BURNER
36	1000-925	BURNER—IR ASM

H. PARTS LIST (CONTINUED)

REAR SCRAPER/EXIT RAMP COMPONENTS

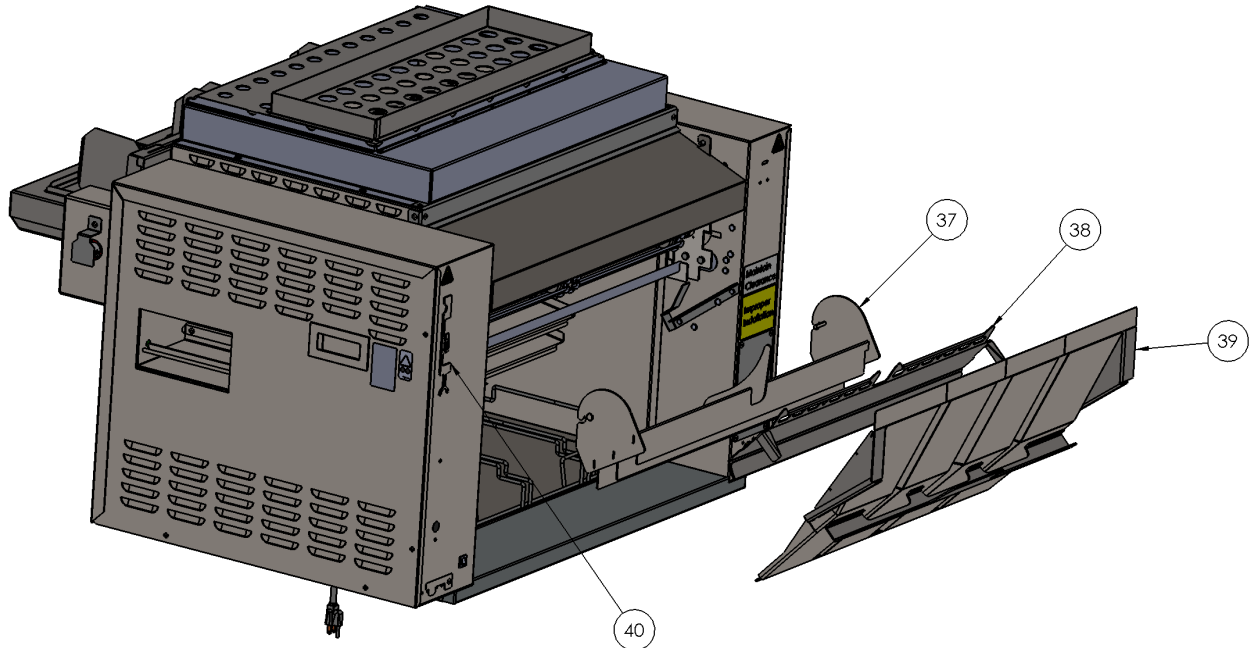

ITEM #	PART #	DESCRIPTION
37	1000-527	SHIELD—HEAT, EXIT RAMP
38	1000-364	SCRAPER—REAR
39	1000-353	RAMP—EXIT, NON TEFLON
40	1000-753	TOOL—CLEANING

H. PARTS LIST (CONTINUED)

LANDING ZONE/HEAT SHIELD COMPONENTS

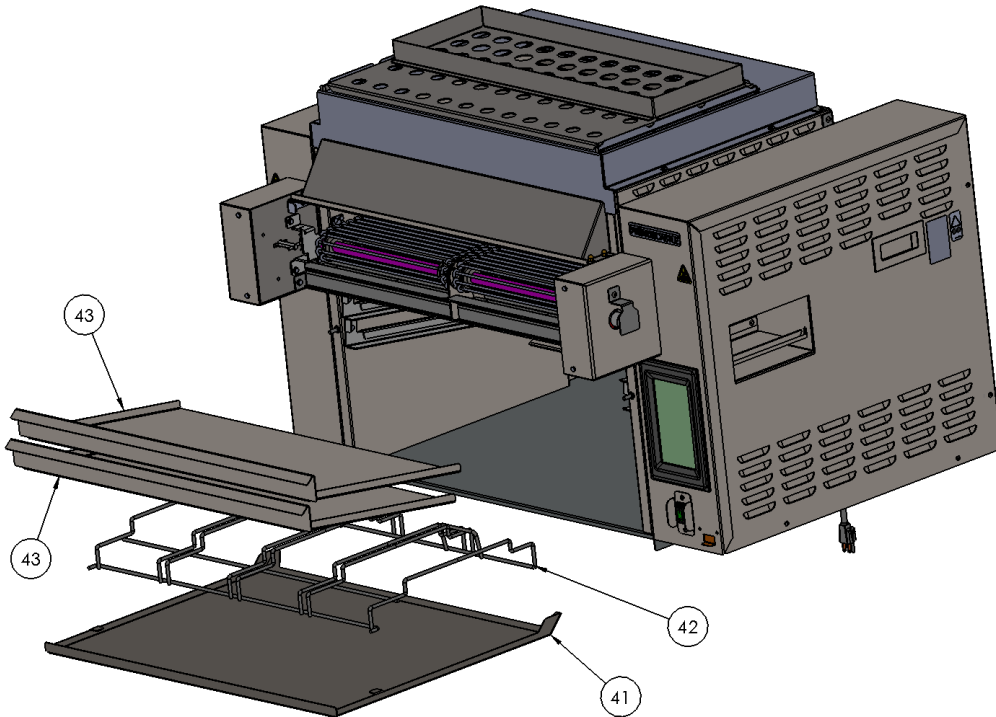

ITEM #	PART #	DESCRIPTION
41	1000-347	TRAY—LANDING ZONE
42	1000-343	RACK—HOLDING PANS
43	1000-360	PAN—GREASE/HEAT SHIELD

H. PARTS LIST (CONTINUED)

THERMOCOUPLES

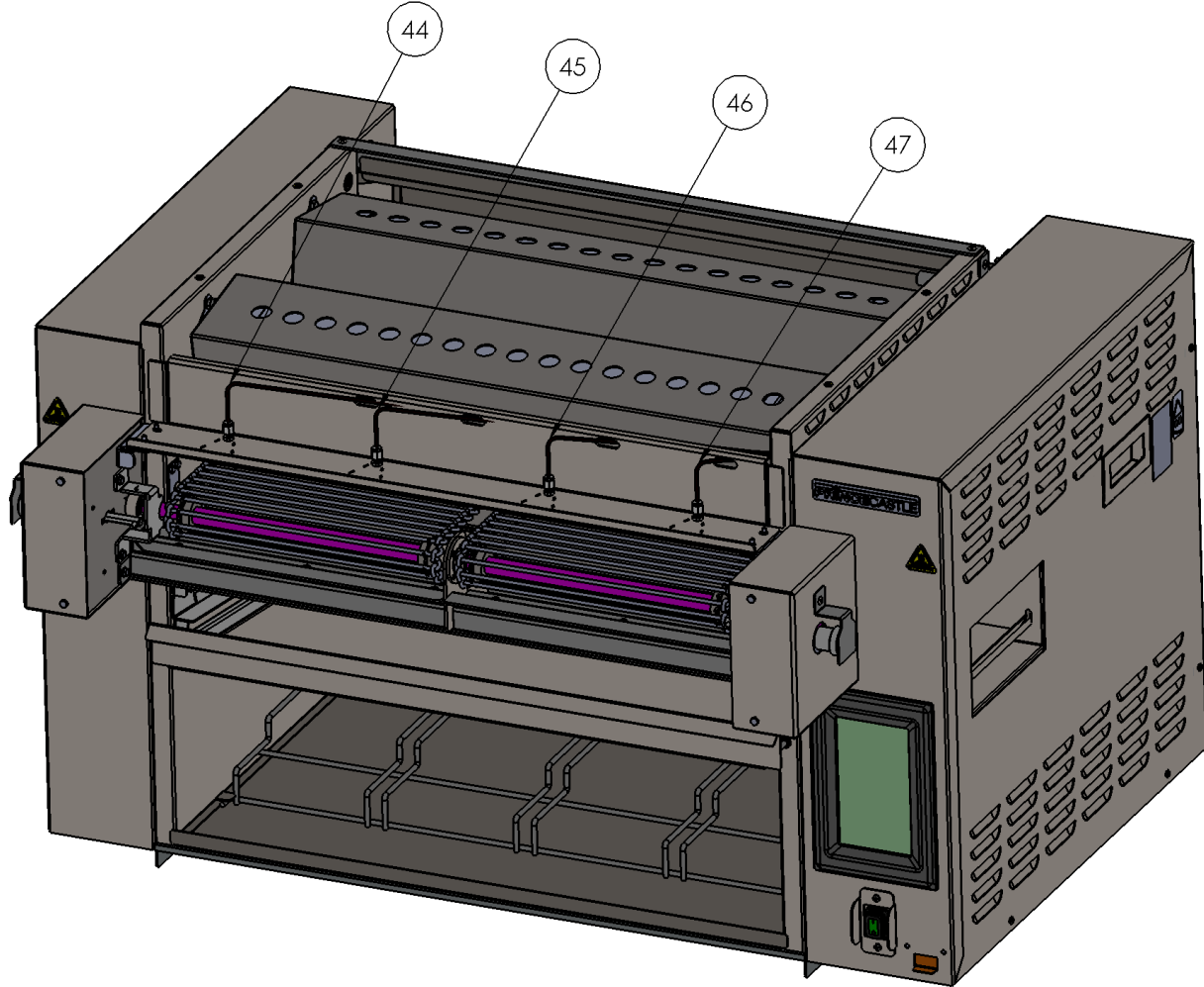

ITEM #	PART #	DESCRIPTION
44	1000-414	SENSOR—THERMOCOUPLE #1
45	1000-415	SENSOR—THERMOCOUPLE #2
46	1000-416	SENSOR—THERMOCOUPLE #3
47	1000-417	SENSOR—THERMOCOUPLE #4

H. PARTS LIST (CONTINUED)

Chains

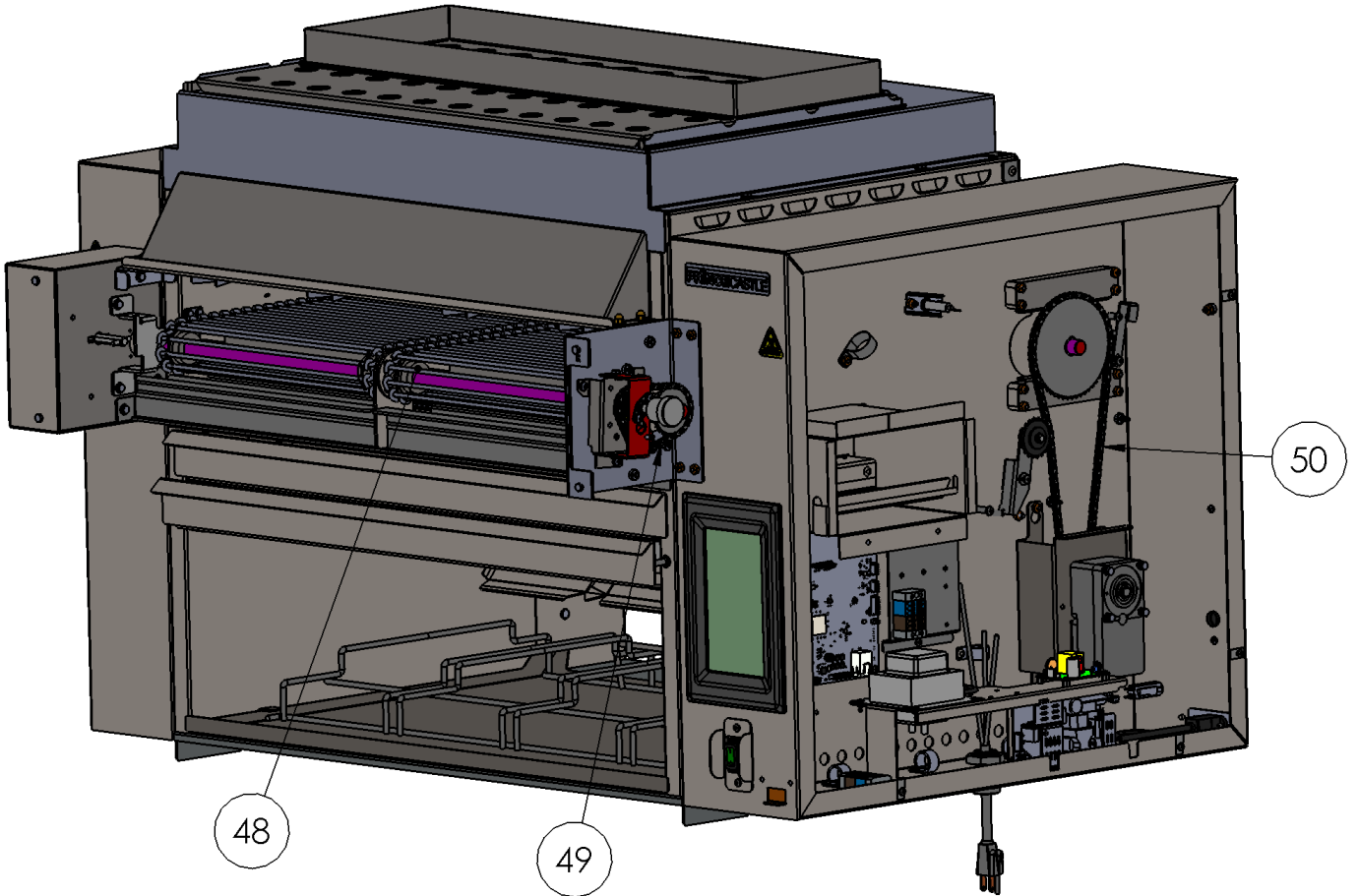

ITEM #	PART #	DESCRIPTION
48	1000-228	CHAIN—GRILL
49	1000-504	CHAIN—#25 ROLLER, AUTO FEEDER
50	1000-927	CHAIN—#25 ROLLER, MAIN DRIVE

H. PARTS LIST (CONTINUED)

Exhaust

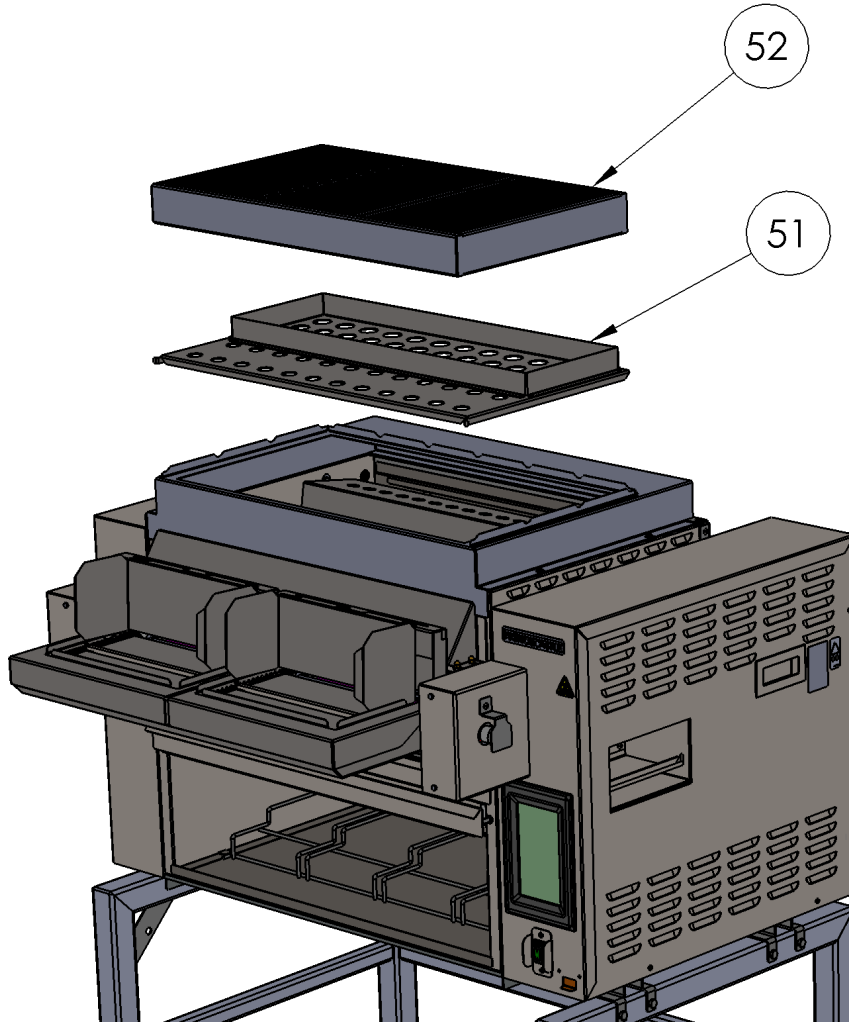

ITEM #	PART #	DESCRIPTION
51	1000-565	ASSY—IMPEDANCE PLATE
52	1000-552	CATALYST—BROILER (OPTIONAL)

H. PARTS LIST (CONTINUED)

CART

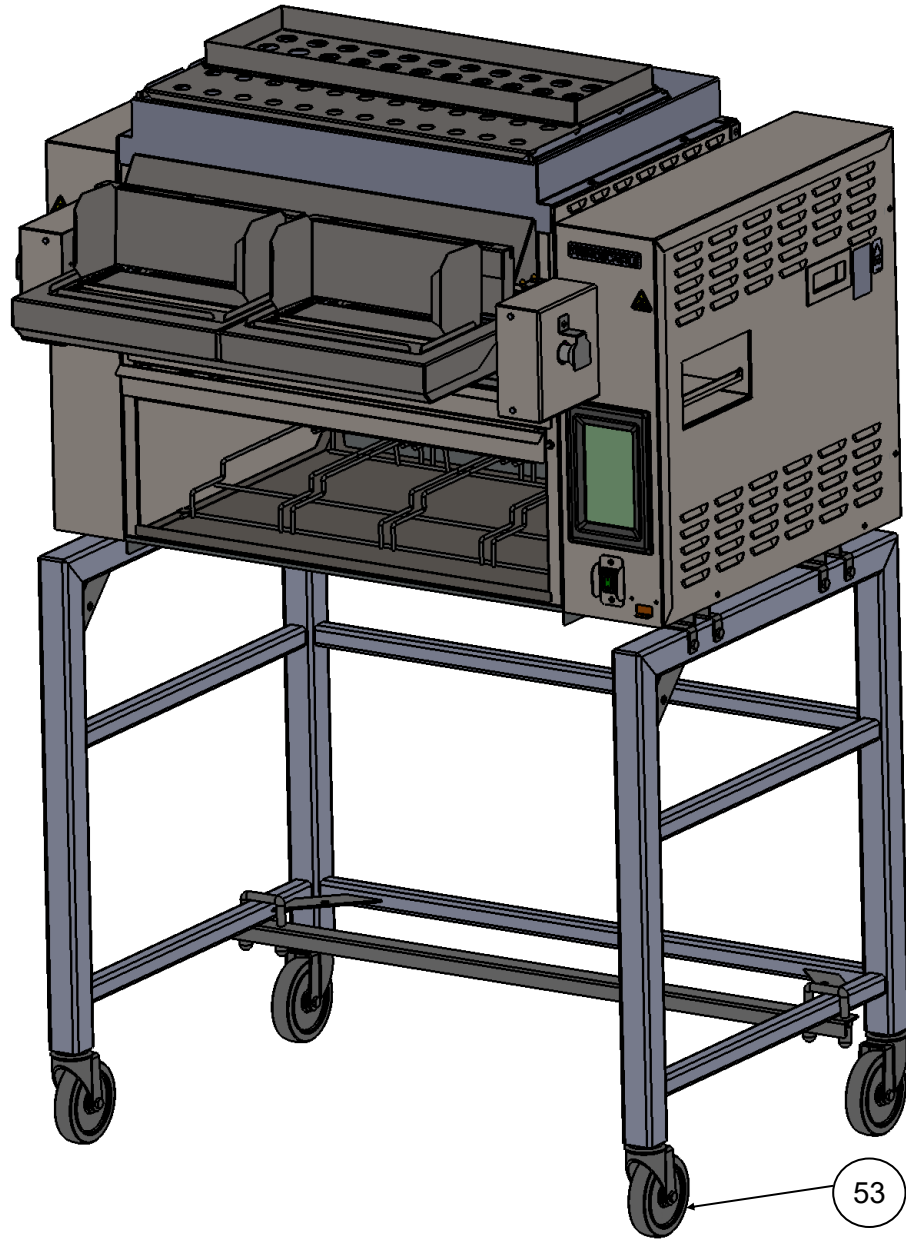

ITEM #	PART #	DESCRIPTION
53	1000-212	CASTER W/BRAKE

I. WIRING DIAGRAM

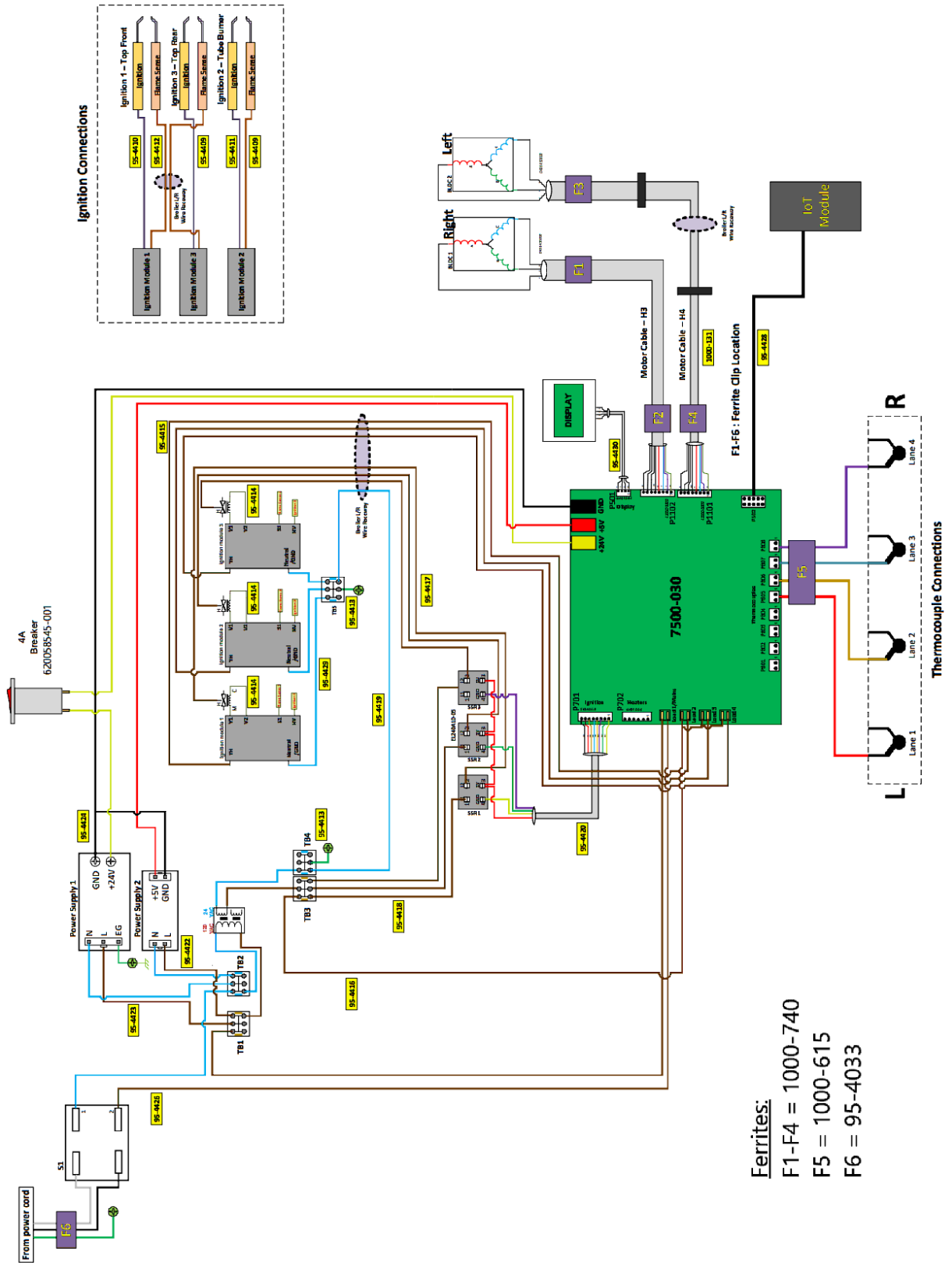



Prince Castle

355 East Kehoe Blvd.

Carol Stream IL, 60188 USA

800-PCASTLE

(630) 462-8800

www.princecastle.com