

Service Manual

Telephone Equipment

Caller ID Compatible

DECT
6.0

 Bluetooth®

Model No. **KX-TG155SK**
KX-TGA660M

Link-to-Cell Cellular Convergence
Solution

M: Metallic Grey Version
(for U.S.A.)



KX-TGA660M
(Handset)

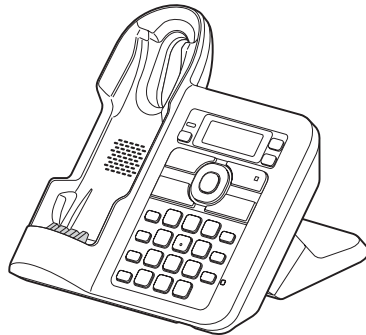

KX-TG7641M
(Base Unit)

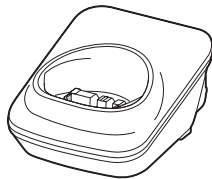

(Charger Unit)

Configuration for each model

| Model No | Base Unit | Handset | Charger Unit | Expandable |
|------------|------------|------------|--------------|------------|
| KX-TG155 | 1 (TG7641) | 5 (TGA660) | 4 | Up to 6 |
| KX-TGA660* | | 1 (TGA660) | 1 | |

*KX-TGA660 is also an optional accessory, which contains a handset and a charger.

Information for optional accessories

You can expand your phone system by registering optional handsets (KX-TGA410) to a single base unit. Optional handsets and the supplied handset are different model so that some functions may not be available. Refer to each Operating Instruction for details.

Panasonic®

© Panasonic System Networks Co., Ltd. 2012
Unauthorized copying and distribution is a violation of law.

 **WARNING**

This service information is designed for experienced repair technicians only and is not designed for use by the general public. It does not contain warnings or cautions to advise non-technical individuals of potential dangers in attempting to service a product. Products powered by electricity should be serviced or repaired only by experienced professional technicians. Any attempt to service or repair the product or products dealt with in this service information by anyone else could result in serious injury or death.

IMPORTANT SAFETY NOTICE

There are special components used in this equipment which are important for safety. These parts are marked by  in the Schematic Diagrams, Circuit Board Diagrams, Exploded Views and Replacement Parts List. It is essential that these critical parts should be replaced with manufacturer's specified parts to prevent shock, fire or other hazards. Do not modify the original design without permission of manufacturer.

IMPORTANT INFORMATION ABOUT LEAD FREE, (PbF), SOLDERING

If lead free solder was used in the manufacture of this product, the printed circuit boards will be marked PbF. Standard leaded, (Pb), solder can be used as usual on boards without the PbF mark. When this mark does appear, please read and follow the special instructions described in this manual on the use of PbF and how it might be permissible to use Pb solder during service and repair work.

- When you note the serial number, write down all 11 digits. The serial number may be found on the bottom of the unit.
- The illustrations in this Service Manual may vary slightly from the actual product.

TABLE OF CONTENTS

| | PAGE | | PAGE |
|--|-----------|--|-----------|
| 1 Safety Precautions ----- | 4 | 14.8. Schematic Diagram (Charger Unit)----- | 83 |
| 1.1. For Service Technicians ----- | 4 | 15 Printed Circuit Board ----- | 85 |
| 2 Warning ----- | 4 | 15.1. Circuit Board (Base Unit_Main) ----- | 85 |
| 2.1. Battery Caution----- | 4 | 15.2. Circuit Board (Base Unit_Operation)----- | 87 |
| 2.2. About Lead Free Solder (PbF: Pb free)----- | 4 | 15.3. Circuit Board (Base Unit_LED)----- | 88 |
| 2.3. Discarding of P. C. Board----- | 5 | 15.4. Circuit Board (Handset_Main)----- | 89 |
| 3 Specifications ----- | 6 | 15.5. Circuit Board (Handset_LED)----- | 91 |
| 4 Technical Descriptions ----- | 7 | 15.6. Circuit Board (Charger Unit)----- | 92 |
| 4.1. Circuit Configuration of TG764x Series Phones ----- | 7 | 16 Exploded View and Replacement Parts List ----- | 93 |
| 4.2. US-DECT Description----- | 8 | 16.1. Cabinet and Electrical Parts (Base Unit)----- | 93 |
| 4.3. Block Diagram (Base Unit_Main)----- | 10 | 16.2. Cabinet and Electrical Parts (Handset)----- | 94 |
| 4.4. Tel Interface Circuit----- | 11 | 16.3. Cabinet and Electrical Parts (Charger Unit)----- | 95 |
| 4.5. Block Diagram (Base Unit_RF Part)----- | 12 | 16.4. Accessories----- | 96 |
| 4.6. Circuit Operation (Base Unit)----- | 13 | 16.5. Replacement Parts List----- | 97 |
| 4.7. Block Diagram (Handset)----- | 20 | | |
| 4.8. Block Diagram (Handset_RF Part)----- | 21 | | |
| 4.9. Circuit Operation (Handset)----- | 22 | | |
| 4.10. Behavior of Electric Power Failure----- | 24 | | |
| 4.11. Circuit Operation (Charger Unit)----- | 24 | | |
| 4.12. Signal Route----- | 25 | | |
| 5 Location of Controls and Components ----- | 27 | | |
| 6 Installation Instructions ----- | 27 | | |
| 7 Operating Instructions ----- | 27 | | |
| 8 Test Mode ----- | 28 | | |
| 8.1. Engineering Mode----- | 28 | | |
| 9 Service Mode ----- | 32 | | |
| 9.1. How to Clear User Setting (Handset Only)----- | 32 | | |
| 10 Troubleshooting Guide ----- | 33 | | |
| 10.1. Troubleshooting Flowchart----- | 33 | | |
| 11 Disassembly and Assembly Instructions ----- | 49 | | |
| 11.1. Disassembly Instructions----- | 49 | | |
| 11.2. How to Attach the Antenna----- | 53 | | |
| 11.3. How to Replace the Base unit LCD----- | 54 | | |
| 11.4. How to Replace the Handset LCD----- | 56 | | |
| 12 Measurements and Adjustments ----- | 57 | | |
| 12.1. Equipment Required----- | 57 | | |
| 12.2. The Setting Method of JIG----- | 57 | | |
| 12.3. Adjustment Standard (Base Unit)----- | 61 | | |
| 12.4. Adjustment Standard (Charger Unit)----- | 62 | | |
| 12.5. Adjustment Standard (Handset)----- | 63 | | |
| 12.6. Things to Do after Replacing IC or X'tal----- | 64 | | |
| 12.7. Frequency Table----- | 66 | | |
| 12.8. Bluetooth Frequency Table----- | 67 | | |
| 13 Miscellaneous ----- | 68 | | |
| 13.1. How to Replace the LLP (Leadless Leadframe Package) IC----- | 68 | | |
| 13.2. How to Replace the Flat Package IC----- | 70 | | |
| 13.3. Terminal Guide of the ICs, Transistors and Diodes----- | 72 | | |
| 14 Schematic Diagram ----- | 73 | | |
| 14.1. For Schematic Diagram----- | 73 | | |
| 14.2. Schematic Diagram (Base Unit_Main)----- | 74 | | |
| 14.3. Schematic Diagram (Base Unit_RF)----- | 76 | | |
| 14.4. Schematic Diagram (Base Unit_Operation)----- | 77 | | |
| 14.5. Schematic Diagram (Base Unit_LED)----- | 78 | | |
| 14.6. Schematic Diagram (Handset_Main)----- | 80 | | |
| 14.7. Schematic Diagram (Handset_LED)----- | 82 | | |

1 Safety Precautions

1.1. For Service Technicians

- **Repair service shall be provided in accordance with repair technology information such as service manual so as to prevent fires, injury or electric shock, which can be caused by improper repair work.**

1. When repair services are provided, neither the products nor their parts or members shall be remodeled.
2. If a lead wire assembly is supplied as a repair part, the lead wire assembly shall be replaced.
3. FASTON terminals shall be plugged straight in and unplugged straight out.

- **ICs and LSIs are vulnerable to static electricity.**

When repairing, the following precautions will help prevent recurring malfunctions.

1. Cover plastic parts boxes with aluminum foil.
2. Ground the soldering irons.
3. Use a conductive mat on worktable.
4. Do not grasp IC or LSI pins with bare fingers.

2 Warning

2.1. Battery Caution

Risk of explosion if battery is replaced by an incorrect type. Dispose of used batteries according to the instructions.

2.2. About Lead Free Solder (PbF: Pb free)

Note:

In the information below, Pb, the symbol for lead in the periodic table of elements, will refer to standard solder or solder that contains lead.

We will use PbF solder when discussing the lead free solder used in our manufacturing process which is made from Tin (Sn), Silver (Ag), and Copper (Cu).

This model, and others like it, manufactured using lead free solder will have PbF stamped on the PCB. For service and repair work we suggest using the same type of solder.

Caution

- PbF solder has a melting point that is 50 °F ~ 70 °F (30 °C ~ 40 °C) higher than Pb solder. Please use a soldering iron with temperature control and adjust it to 700 °F ± 20 °F (370 °C ± 10 °C).
- Exercise care while using higher temperature soldering irons.:
Do not heat the PCB for too long time in order to prevent solder splash or damage to the PCB.
- PbF solder will tend to splash if it is heated much higher than its melting point, approximately 1100 °F (600 °C).
- When applying PbF solder to double layered boards, please check the component side for excess which may flow onto the opposite side (See the figure below).

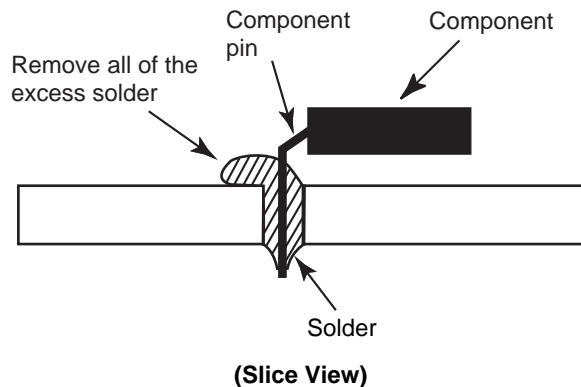

2.2.1. Suggested PbF Solder

There are several types of PbF solder available commercially. While this product is manufactured using Tin, Silver, and Copper (Sn+Ag+Cu), you can also use Tin and Copper (Sn+Cu), or Tin, Zinc, and Bismuth (Sn+Zn+Bi). Please check the manufacturer's specific instructions for the melting points of their products and any precautions for using their product with other materials.

The following lead free (PbF) solder wire sizes are recommended for service of this product: 0.3 mm, 0.6 mm and 1.0 mm.

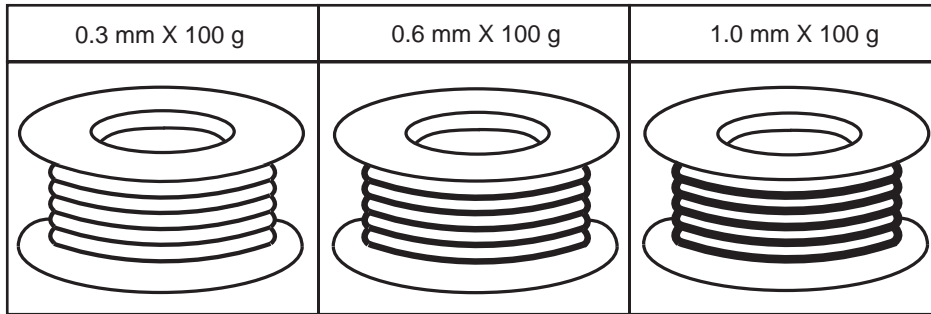

2.3. Discarding of P. C. Board

When discarding P. C. Board, delete all personal information such as telephone directory and caller list or scrap P. C. Board.

3 Specifications

■ Standard:

DECT 6.0 (Digital Enhanced Cordless Telecommunications 6.0)
Bluetooth wireless technology 2.0

■ Number of channels:

60 Duplex Channels (DECT 6.0)
79 Duplex channels (Bluetooth)

■ Frequency range:

1.92 GHz to 1.93 GHz (DECT 6.0)
2.402 GHz to 2.48 GHz (Bluetooth)

■ Duplex procedure:

TDMA (Time Division Multiple Access)

■ Channel spacing:

1.728MHz (DECT 6.0)
1.0MHz (Bluetooth)

■ Bit rate:

1.152Mbit/s (DECT 6.0)
1.0 Mbit/s (Bluetooth)

■ Modulation:

GFSK (Gaussian Frequency Shift Keying)

■ RF transmission power:

115 mW (max/DECT6.0)

■ Voice coding:

ADPCM 32 kbit/s (DECT 6.0)
CVSD/PCM 64kbit/s (Bluetooth)
PCM 64kbit/s (BT_IC)

| | Base Unit | Handset | Charger |
|------------------------------|---|---|---|
| Power source | AC Adaptor (PNLV226Z, 120 V AC, 60 Hz) | Rechargeable Ni-MH battery AAA (R03) size (1.2 V 550 mAh) | AC Adaptor (PNLV226Z, 120 V AC, 60 Hz) |
| Receiving Method | Super Heterodyne | Super Heterodyne | _____ |
| Oscillation Method | PLL synthesizer | PLL synthesizer | _____ |
| Detecting Method | Quadrature Discriminator | Quadrature Discriminator | _____ |
| Tolerance of OSC Frequency | 10.368 MHz ±100 Hz | 13.824 MHz ±100 Hz | _____ |
| Modulation Method | Frequency Modulation | Frequency Modulation | _____ |
| ID Code | 40 bit | 40 bit | _____ |
| Ringer Equivalence No. (REN) | 0.1B | _____ | _____ |
| Dialing Mode | Tone (DTMF)/Pulse | Tone (DTMF)/Pulse | _____ |
| Redial | Up to 48 digits | Up to 48 digits | _____ |
| Speed Dialer | _____ | Up to 24 digits (Phonebook) | _____ |
| Power Consumption | Standby: Approx. 1.5 W Maximum: Approx. 4.8 W | 11 days at Standby, 13 hours at Talk | Standby: Approx. 0.1 W Maximum: Approx. 2.0 W |
| Operating Conditions | 0 °C - 40 °C (32 °F - 104 °F) 20 % - 80 % relative air humidity (dry) | 0 °C - 40 °C (32 °F - 104 °F) 20 % - 80 % relative air humidity (dry) | 0 °C - 40 °C (32 °F - 104 °F) 20 % - 80 % relative air humidity (dry) |
| Dimensions (H x W x D) | Approx. 134 mm x 159 mm x 180 mm | Approx. 173 mm x 48 mm x 32 mm | Approx. 44 mm x 73 mm x 79 mm |
| Mass (Weight) | Approx. 380 g | Approx. 140 g | Approx. 50 g |

Note:

- Design and specifications are subject to change without notice.

Note for Service:

- **Operation range:** Up to 300 m outdoors, Up to 50 m indoors, depending on the condition.
- **Analog telephone connection:** Telephone Line
- **Optional headset:** KX-TCA60, KX-TCA93, KX-TCA94, KX-TCA400, KX-TCA430
- **Optional Range extender:** KX-TGA405

4 Technical Descriptions

4.1. Circuit Configuration of TG764x Series Phones

TG764x consists of DECT cordless telephone and Bluetooth Module.

Both voices of transmission and reception are transferred by PCM.

BBIC on DECT side controls the cordless telephone system, which makes control data communication with BT_IC on BT Module in serial data.

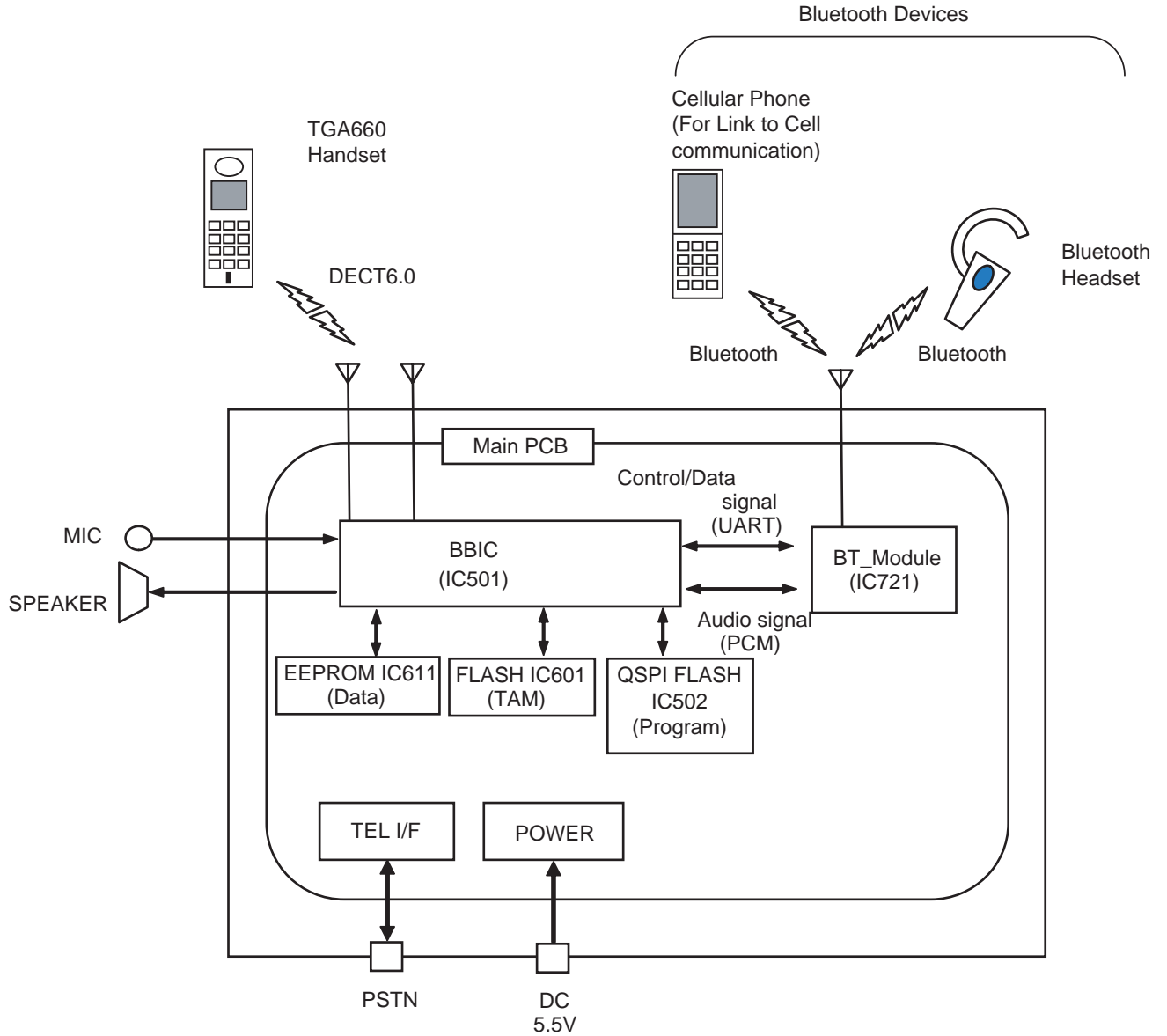

4.2.3. Signal Flowchart in the Radio Parts

Reception

Base unit:

A voice signal from TEL line is encoded to digital data and converted into a 1.9GHz modulated radio signal by BBIC(IC501). The RF signal, after which is amplified in BBIC, is fed to selected antenna.

Handset:

As for a handset RF, RF signal is received in one antenna.

BBIC down-converts to 864 kHz IF signal from RX signal and demodulates it to digital data "RXDATA".

BBIC (IC1) converts RXDATA into a voice signal and outputs it to speaker.

Transmission

Handset:

A voice signal from microphone is encoded to digital data and converted into a 1.9GHz modulated radio signal by BBIC(IC1). The RF signal, after which is amplified in BBIC, is fed to an antenna.

Base unit:

As for a base unit RF, RF signal is received in two antennas.

BBIC (IC501) compares RF signal levels and selects the antenna to be used. Then BBIC down-converts to 864 kHz IF signal from RX signal in the selected antenna, and demodulates it to digital data "RXDATA".

BBIC (IC501) converts RXDATA into a voice signal and outputs it to TEL line.

4.3. Block Diagram (Base Unit_Main)

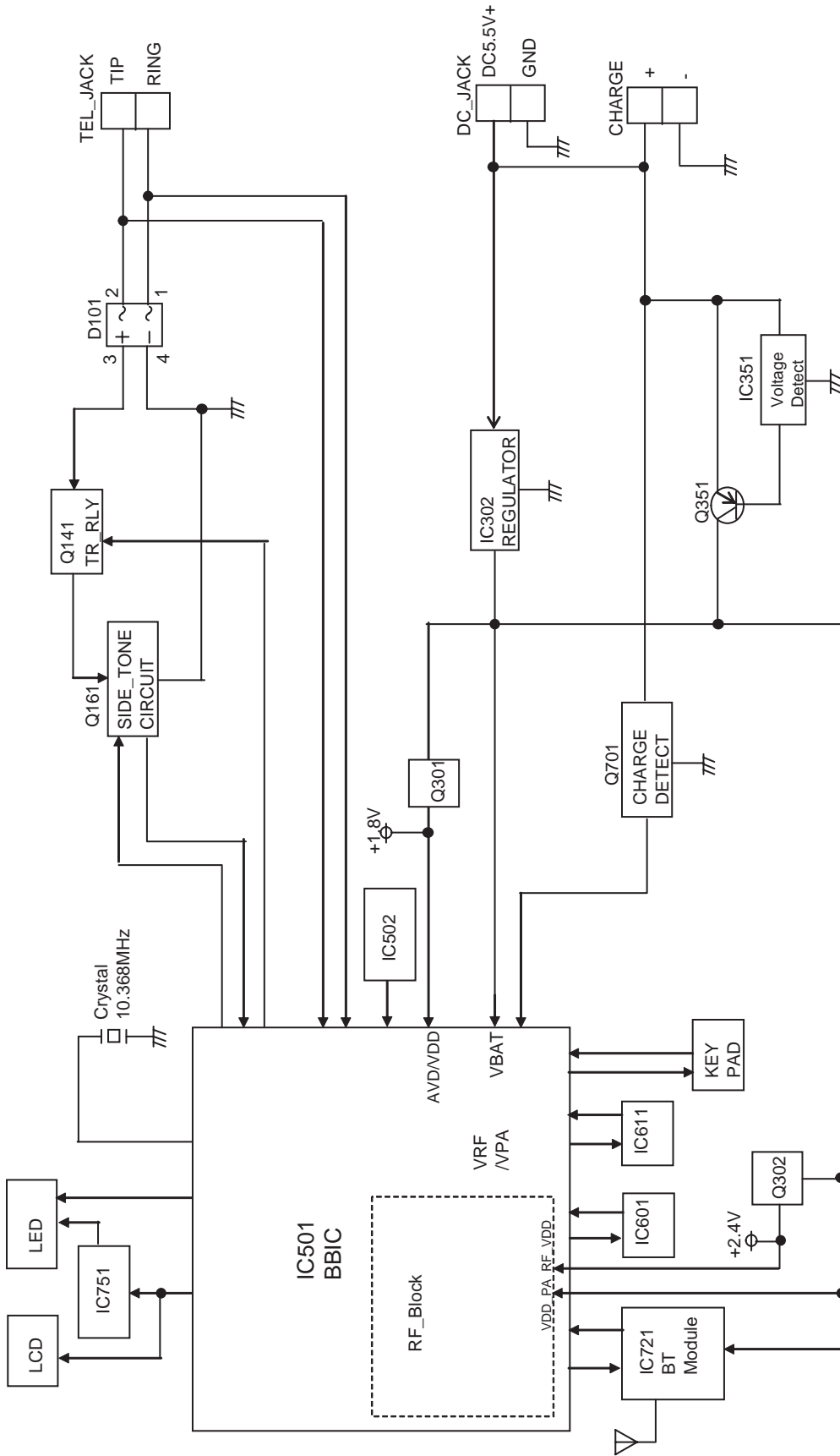

KX-TG155 BLOCK DIAGRAM (Base Unit_Main)

4.4. Tel Interface Circuit

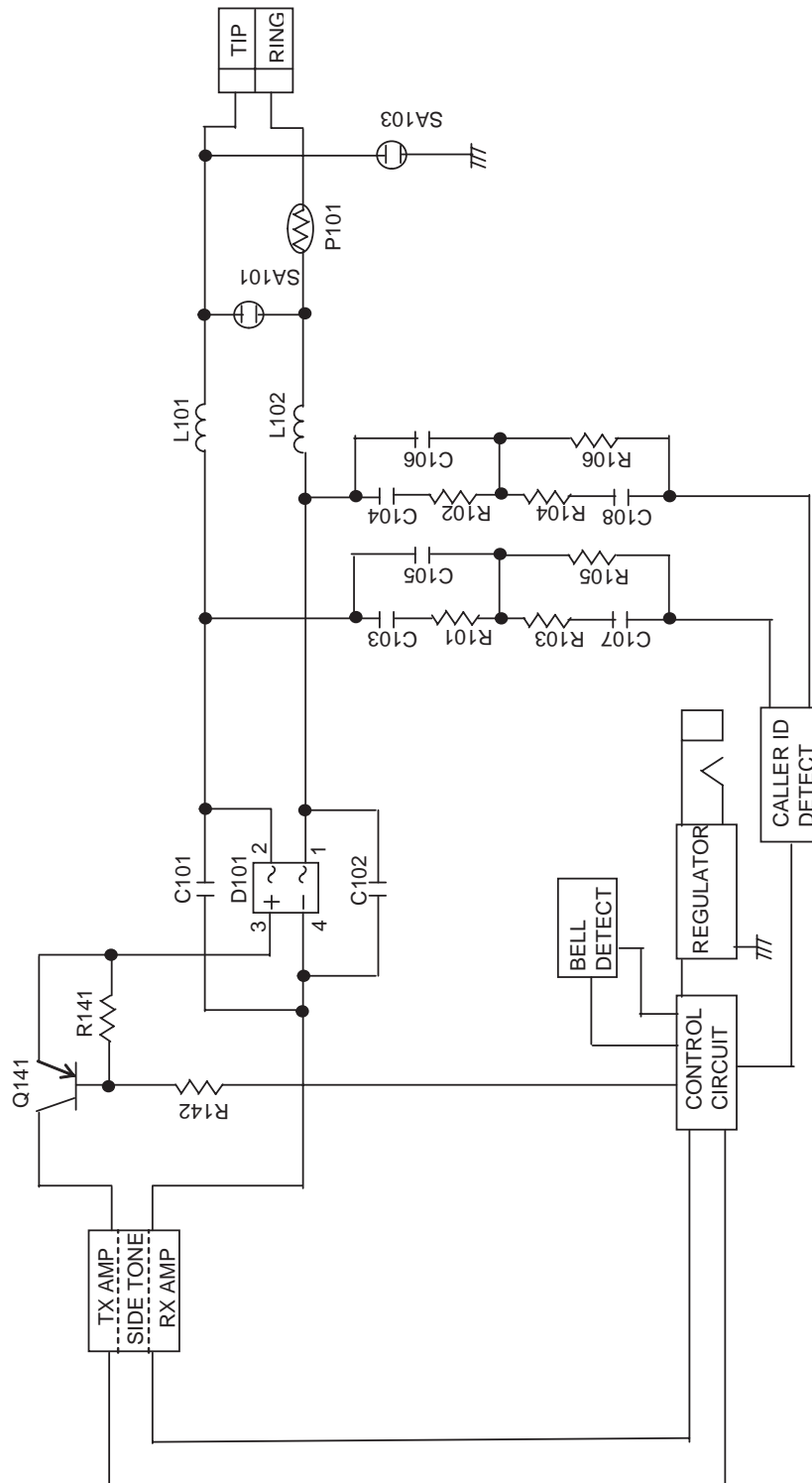

4.5. Block Diagram (Base Unit_RF Part)

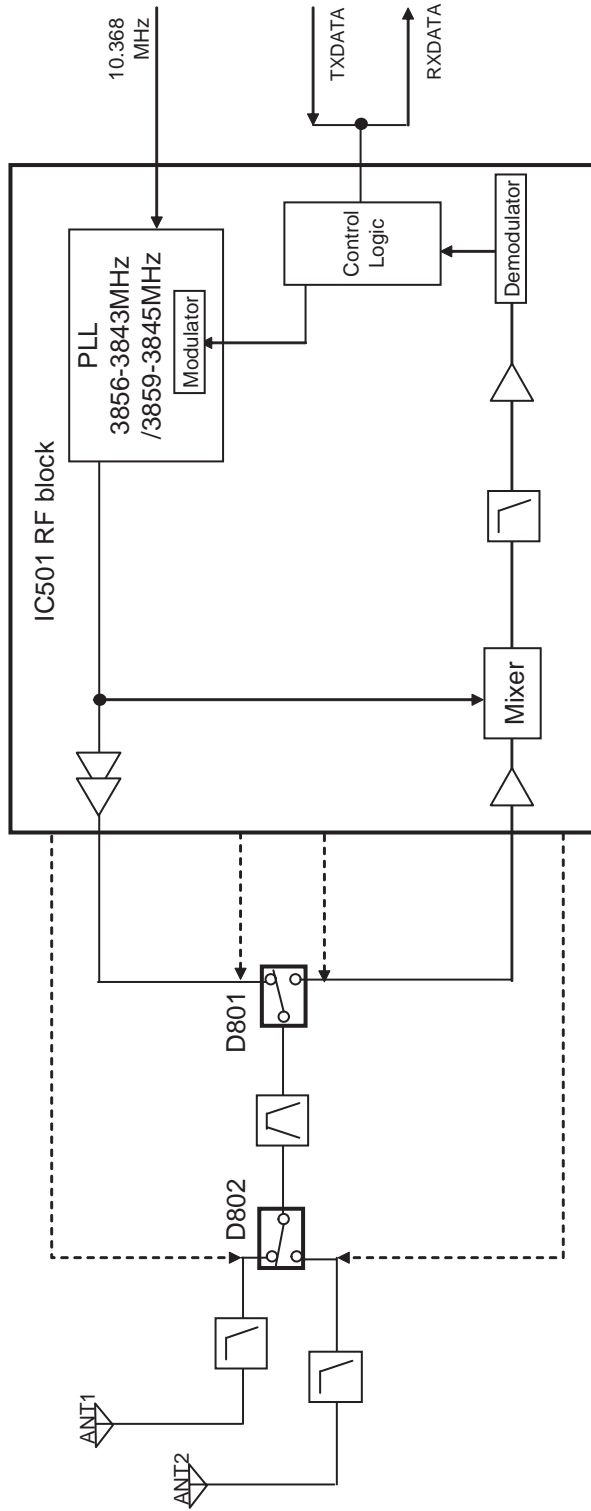

KX-TG155 BLOCK DIAGRAM (Base Unit_RF Part)

4.6. Circuit Operation (Base Unit)

General Description:

(BBIC, Flash Memory, EEPROM) is a digital speech/signal processing system that implements all the functions of speech compression, record and playback, and memory management required in a digital telephone answering machine.

The BBIC system is fully controlled by a host processor. The host processor provides activation and control of all that functions as follows.

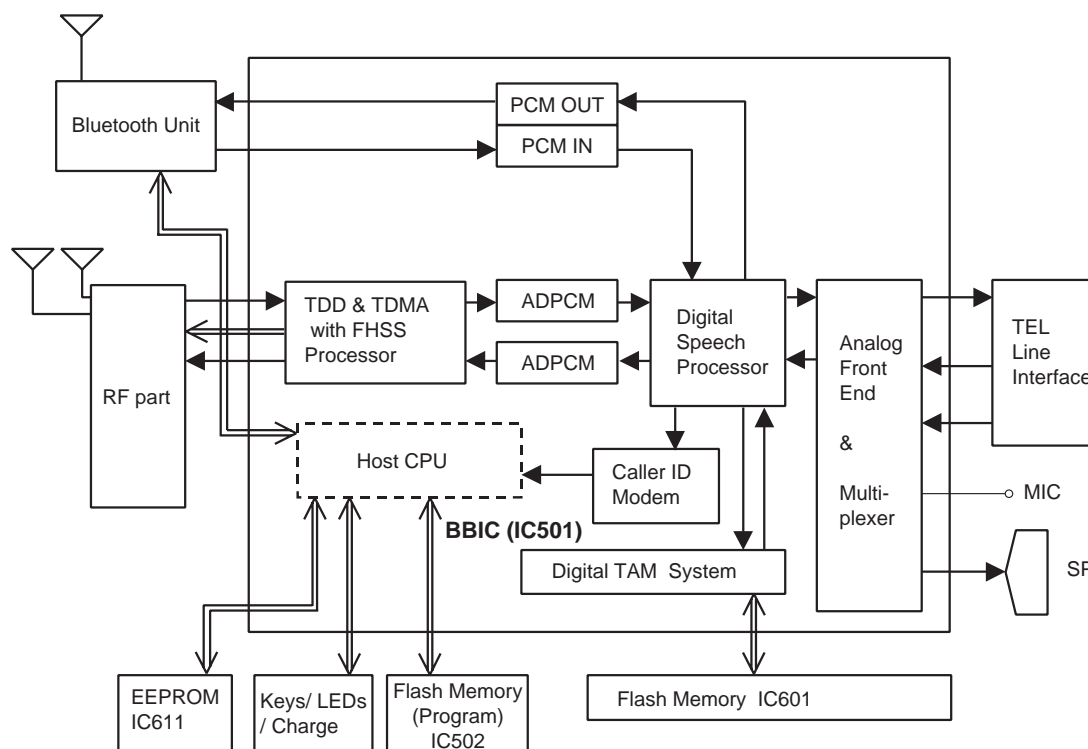

4.6.1. BBIC (Base Band IC: IC501)

- **Voice Message Recording/Play back**

The BBIC system uses a proprietary speech compression technique to record and store voice message in Flash Memory. An error correction algorithm is used to enable playback of these messages from the Flash Memory.

- **DTMF Generator**

When the DTMF data from the handset is received, the DTMF signal is output.

- **Synthesized Voice (Pre-recorded message)**

The BBIC implements synthesized Voice, utilizing the built in speech detector and a Flash Memory, which stored the vocabulary.

- **Caller ID demodulation**

The BBIC implements monitor and demodulate the FSK/DTMF signals that provide CID information from the Central Office.

- **Digital Switching**

The voice signal from telephone line is transmitted to the handset or the voice signal from the handset is transmitted to the Telephone line, etc. They are determined by the signal path route operation of voice signal.

- **Block Interface Circuit**

RF part, LED, Key scan, Speaker, Telephone line.

4.6.2. Flash Memory (IC502)

Main program data is stored.

4.6.3. Flash Memory (IC601)

Following information data is stored.

- **Voice signal**

ex: Pre-recorded Greeting message, Incoming message

4.6.4. EEPROM (IC611)

Following information data is stored.

- **Settings**

ex: message numbers, ID code, Flash Time, Tone/Pulse

4.6.5. Bluetooth Unit (IC721)

Use for Bluetooth communication.

4.6.6. Power Supply Circuit/Reset Circuit

The power supply voltage from AC adaptor is converted to VBAT (3.0V) in IC302. And +3.0V for peripherals and analog part is insulated from VBAT by Doubler of BBIC.

Circuit Operation:

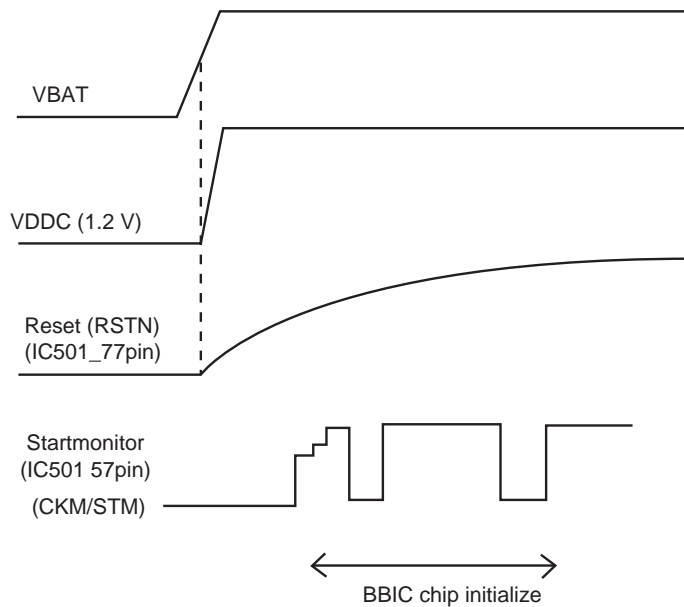
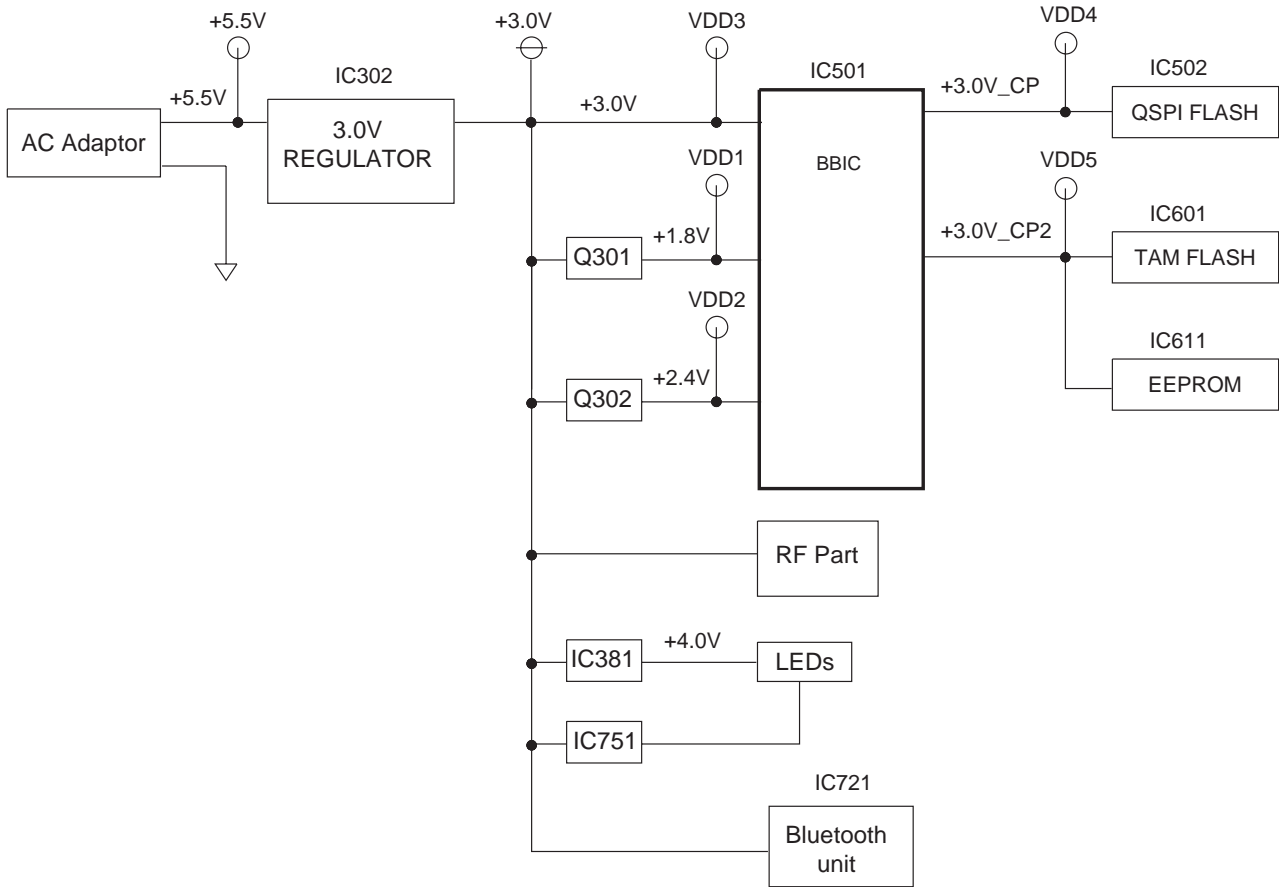

4.6.6.1. Charge Circuit

The voltage from the AC adaptor is supplied to the charge circuits.

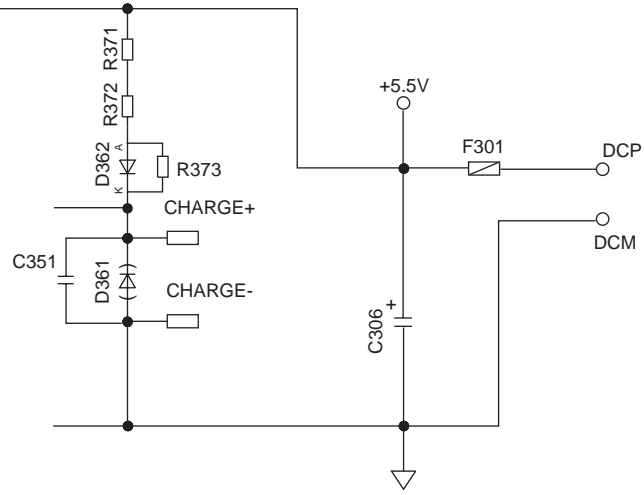

4.6.8. Parallel Connection Detect Circuit/Auto Disconnect Circuit

Function:

In order to disable call waiting and stutter tone functions when using telephones connected in parallel, it is necessary to have a circuit that judges whether a telephone connected in parallel is in use or not. This circuit determines whether the telephone connected in parallel is on hook or off hook by detecting changes in the T/R voltage.

Circuit Operation:

Parallel connection detection when on hook:

When on hook, the voltage is monitored at pin 32 of IC501. There is no parallel connection if the voltage is 0.54 V or higher, while a parallel connection is deemed to exist if the voltage is lower.

Parallel connection detection when off hook:

When off hook, the voltage is monitored at pin 17 of IC501; the presence/absence of a parallel connection is determined by detecting the voltage changes.

If the Auto disconnect function is ON and statuses are Hold, receiving ICM, OGM transmitting, BBIC disconnects the line after detecting parallel connection is off hook.

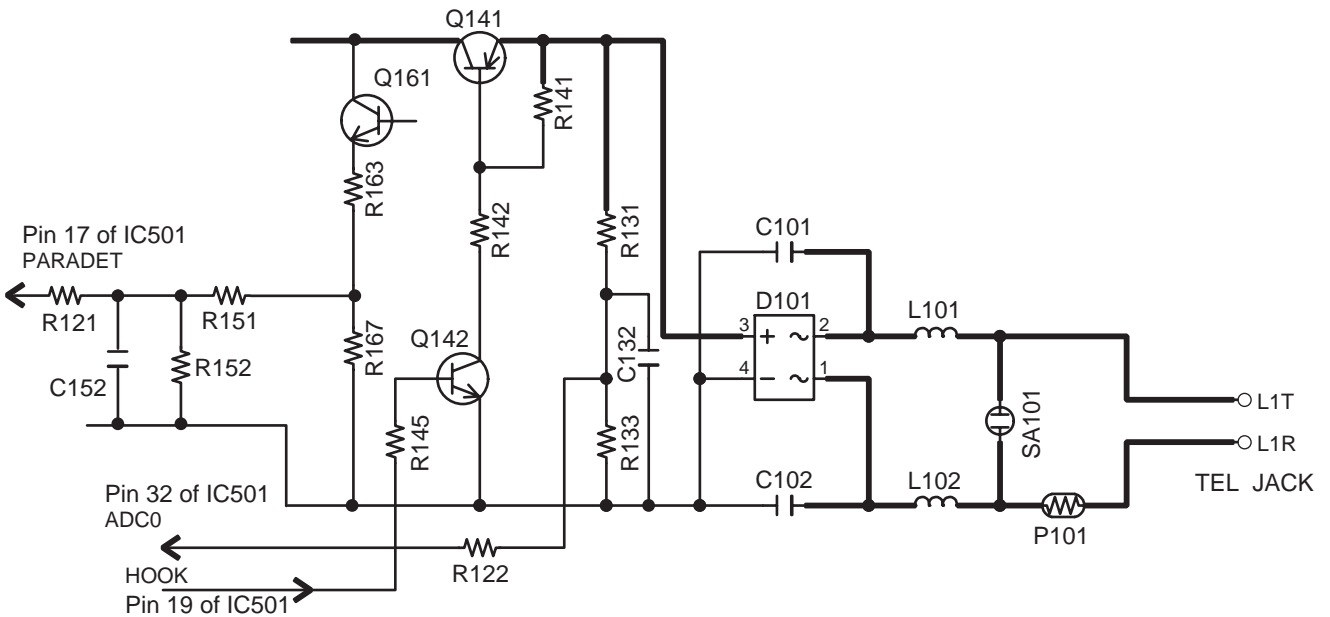

4.6.9. Calling Line Identification (Caller ID)/Call Waiting Caller ID

Function:

Caller ID

The caller ID is a chargeable ID which the user of a telephone circuit obtains by entering a contract with the telephone company to utilize a caller ID service. For this reason, the operation of this circuit assumes that a caller ID service contract has been entered for the circuit being used. The data for the caller ID from the telephone exchange is sent during the interval between the first and second rings of the bell signal. The data from the telephone exchange is a modem signal which is modulated in an FSK (Frequency Shift Keying) * format. Data "1" is a 1200 Hz sine wave, and data "0" is a 2200 Hz sine wave. There are two types of the message format which can be received: i.e. the single message format and plural message format. The plural message format allows to transmit the name and data code information in addition to the time and telephone number data.

*: Also the telephone exchange service provides other formats.

- Single message format

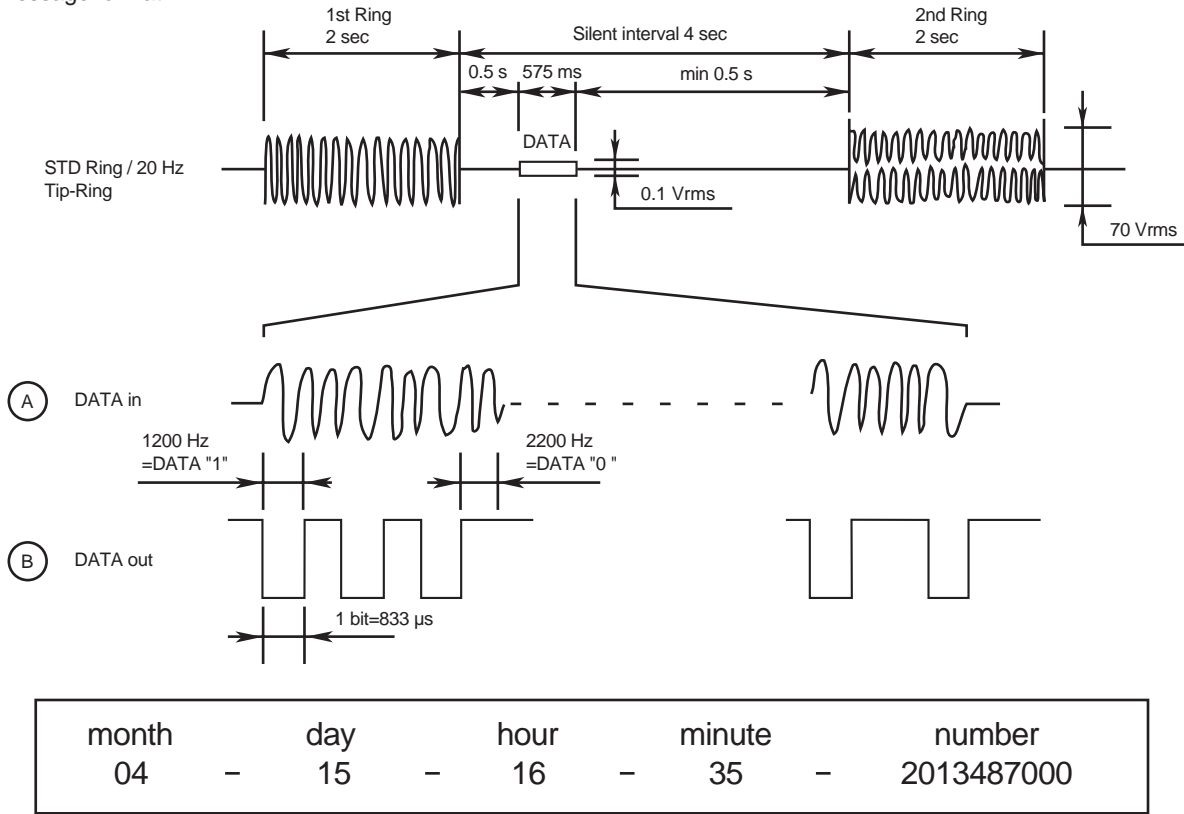

- Plural message format

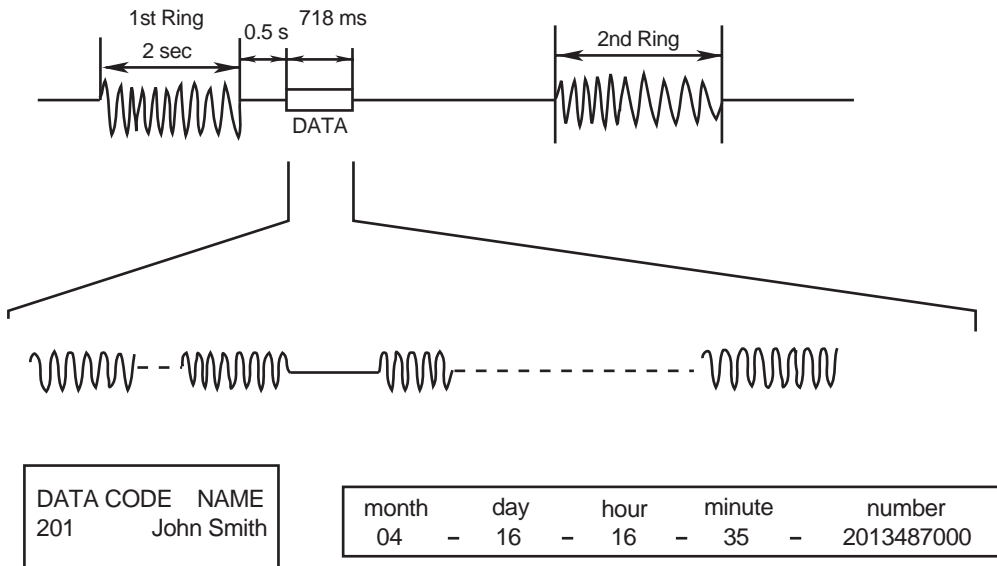

Call Waiting Caller ID

Calling Identity Delivery on Call Waiting (CIDCW) is a CLASS service that allows a customer, while off-hook on an existing call, to receive information about a calling party on a waited call. The transmission of the calling information takes place almost immediately after the customer is alerted to the new call so he/she can use this information to decide whether to take the new call.

Function:

The telephone exchange transmits or receives CAS and ACK signals through each voice RX/TX route. Then FSK data and MARK data pass the following route.

Telephone Line→P101→L101, L102→C105, C106→R105, R106→R108, R107→IC501(23, 21).

If the unit deems that a telephone connected in parallel is in use, ACK is not returned even if CAS is received, and the information for the second and subsequent callers is not displayed on the portable handset display.

Call Waiting Format

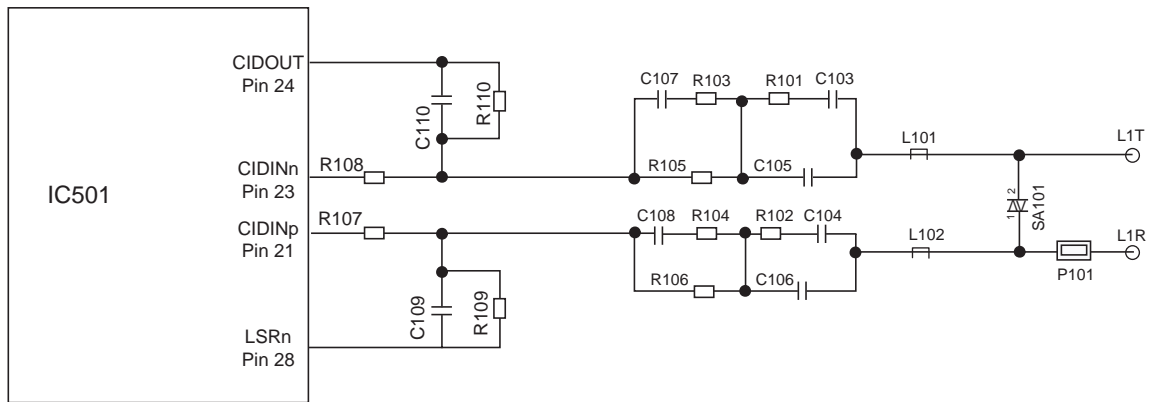
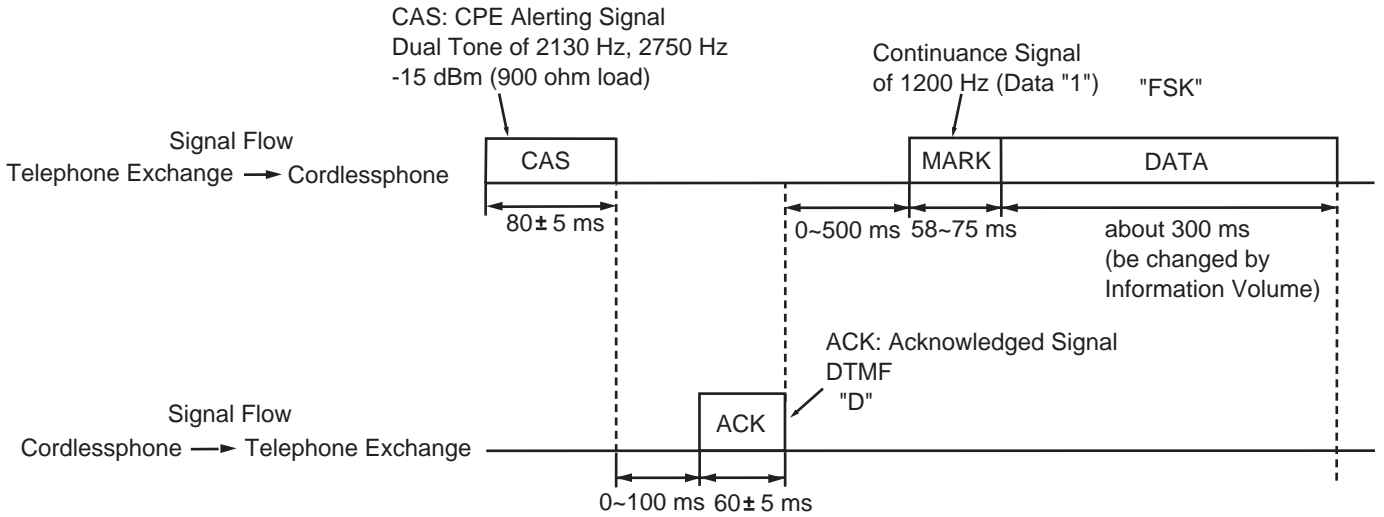

4.7. Block Diagram (Handset)

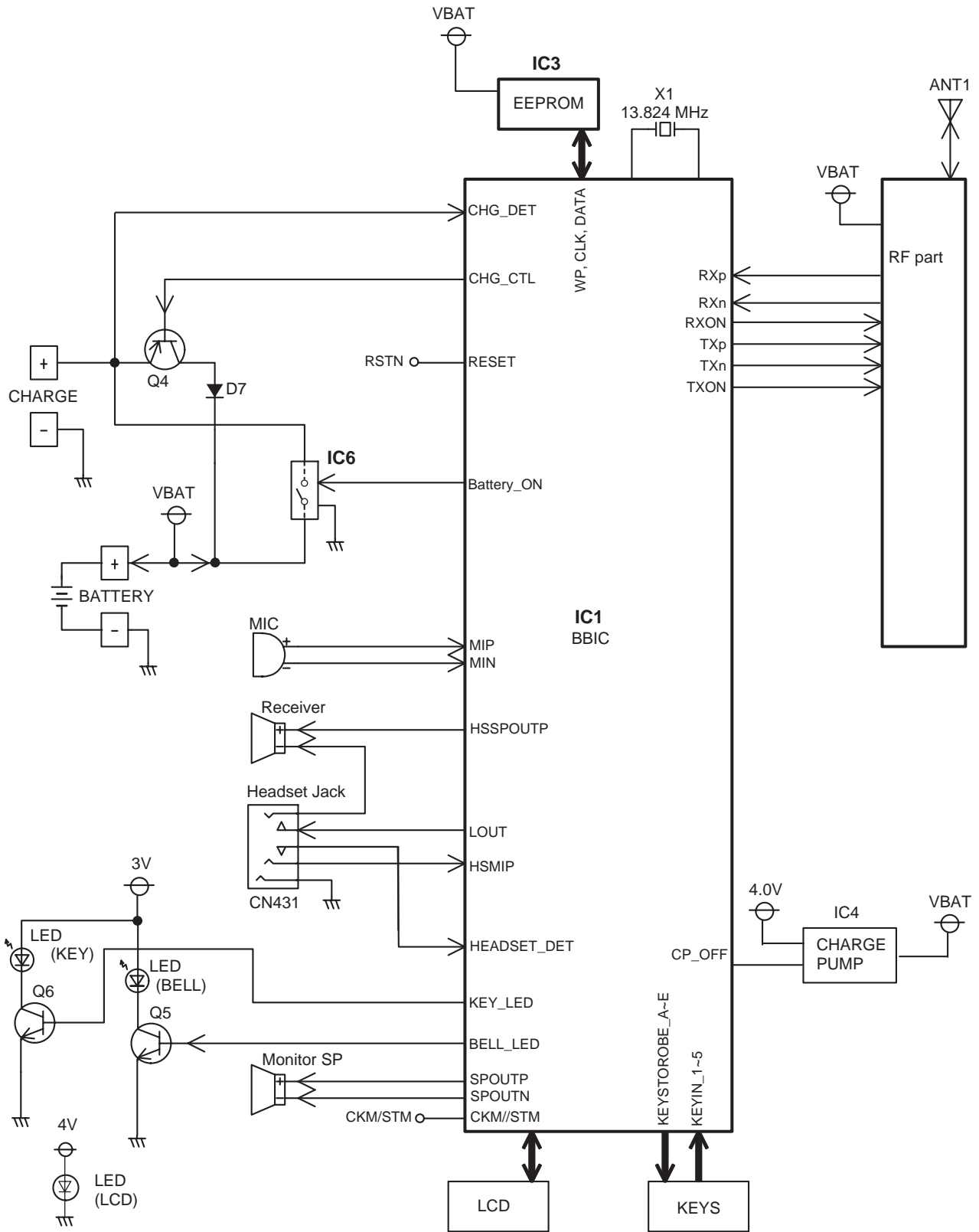

KX-TGA660 BLOCK DIAGRAM (Handset)

4.8. Block Diagram (Handset_RF Part)

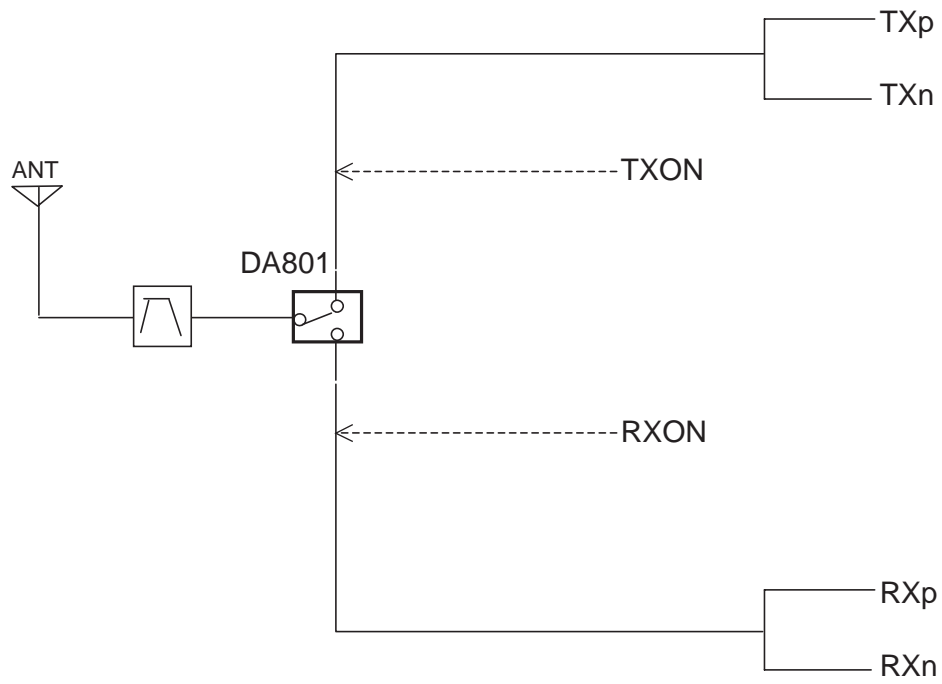

KX-TGA660 BLOCK DIAGRAM (Handset_RF Part)

4.9. Circuit Operation (Handset)

4.9.1. Outline

Handset consists of the following ICs as shown in **Block Diagram (Handset)** (P.20).

- DECT BBIC (**B**ase **B**and IC): IC1
 - All data signals (forming/analyzing ACK or CMD signal)
 - All interfaces (ex: Key, Detector Circuit, Charge, EEPROM, LCD)
- EEPROM: IC3
 - Setting data is stored. (e.g. ID, user setting)

4.9.2. Power Supply Circuit/Reset Circuit

Circuit Operation:

When power on the Handset, the voltage is as follows;

BATTERY(2.2 V ~ 2.6 V: BATT+) → F1 → BBC1 (IC1) 10 pin

The Reset signal generates IC1 (54 pin) and 1.8 V.

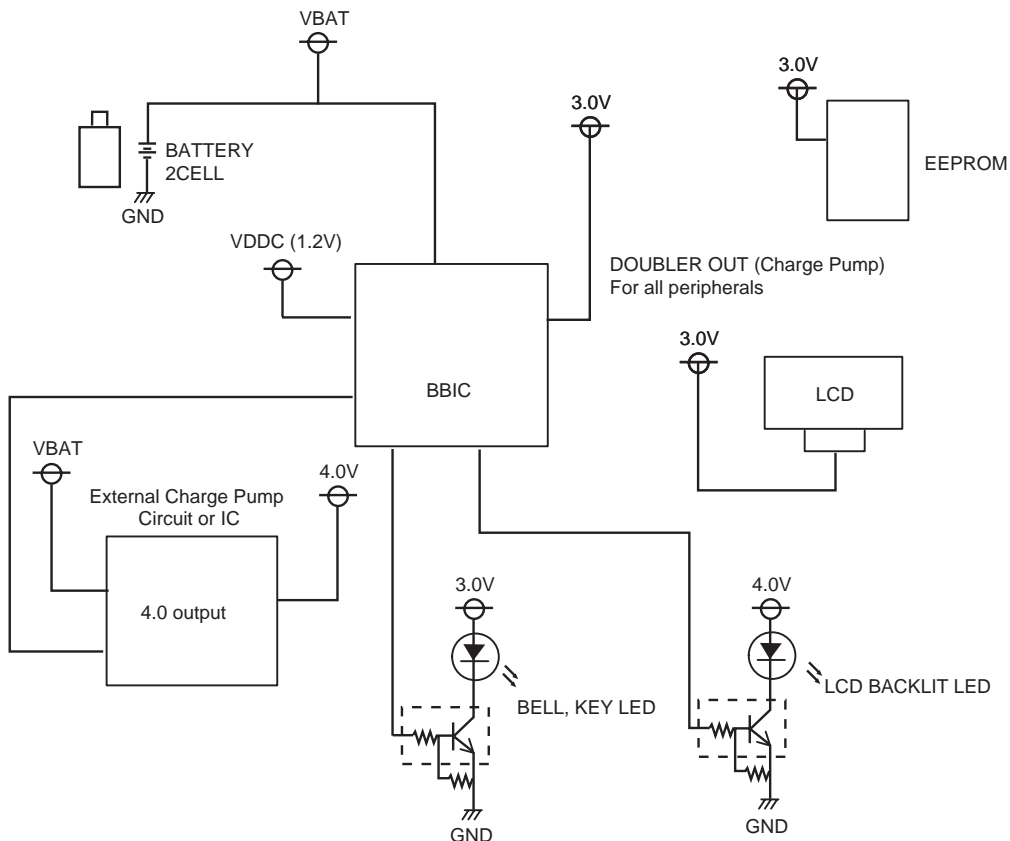
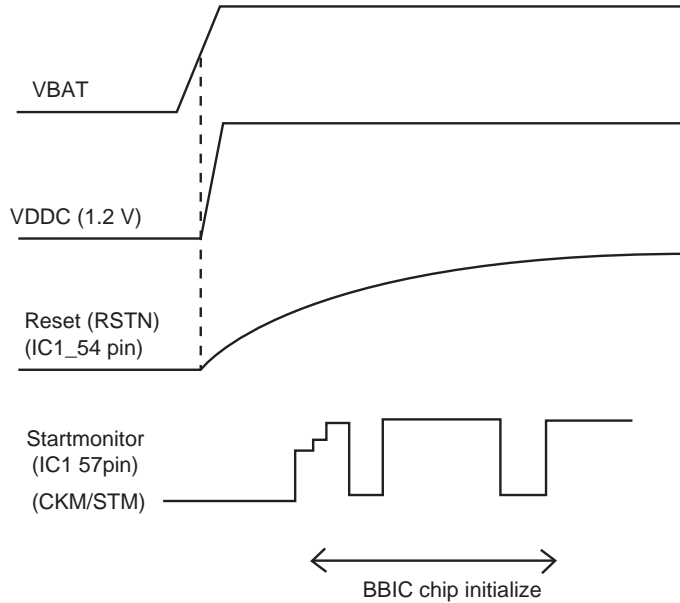

4.10. Behavior of Electric Power Failure

In case that the power from AC adaptor is lost and lose radio waves, BBIC (IC1) turns IC6 ON since handset presumes that base unit's power is failed.

Base unit detects that power voltage of AC adaptor +5.5V is OFF at IC351, then turns Q351 ON.

It's possible to use the units during the power failure, supplying power to VBAT of base unit from battery of handset through IC6, CHG terminal and Q351.

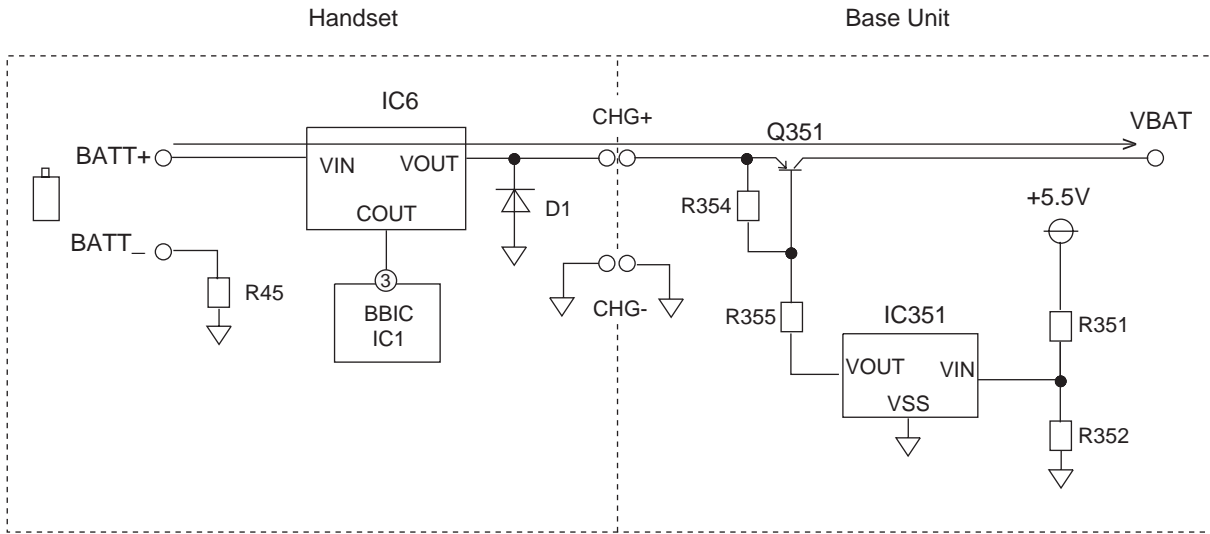

4.11. Circuit Operation (Charger Unit)

Charge control is executed at handset side so that the operation when using charger is also controlled by handset.

Refer to **Circuit Operation (Handset)** (P.22)

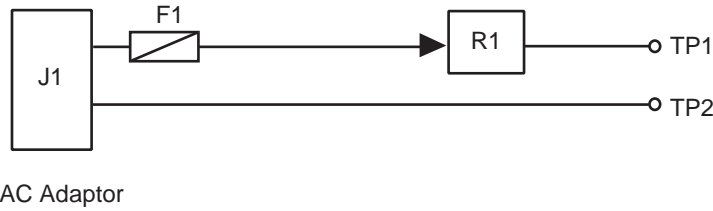

The route for this is as follows: DC+pin of J1(+) → F1 → R1 → CHARGE+pad → Handset → CHARGE-pad → DC-pin of J1(-).

4.12. Signal Route

| SIGNAL ROUTE | IN | → | ROUTE | → | OUT |
|---|----|---|---|---|-----|
| HANDSET TX | | | HANDSET MIC - R73/74 - C11/13 - RA4 - IC1(22/23) - <HANDSET_RF_TX_ROUTE> - ANT. --- | | |
| | | | ANT. - <BASE_UNIT_RF_RX_ROUTE> - IC501(2/3 - 27) - C184 - Q161 - Q141 - D101 - L101/[L102-P101] - T/R (TEL LINE) | | |
| HANDSET RX | | | T/R (TEL LINE) - L101/[P101-L102] - D101 - Q141 - R165 - C173 - R178 - IC501(25 - 94/95) - <BASE_UNIT_RF_TX_ROUTE> - ANT | | |
| | | | --- ANT. - <HANDSET_RF_RX_ROUTE> - IC1(28/27) - C86 - L74 - HEADSET_JACK(5 - 4) - R11 - HANDSET SPEAKER | | |
| HEADSET TX | | | HEADSET_JACK(2) - R306 - C14 - R22 - IC1(25) - <HANDSET_RF_TX_ROUTE> - ANT. --- | | |
| | | | ANT. - <BASE_UNIT_RF_RX_ROUTE> - IC501(2/3 - 27) - C184 - Q161 - Q141 - D101 - L101/[L102-P101] - T/R (TEL LINE) | | |
| HEADSET RX | | | T/R (TEL LINE) - L101/[P101-L102] - D101 - Q141 - R165 - C173 - R178 - IC501(25 - 94/95) - <BASE_UNIT_RF_TX_ROUTE> - ANT | | |
| | | | --- ANT. - <HANDSET_RF_RX_ROUTE> - IC1(28) - C86 - L74 - HEADSET_JACK(5) | | |
| HANDSET SP-Phone TX | | | HANDSET MIC - R73/74 - C11/13 - RA4 - IC1(22/23) - <HANDSET_RF_TX_ROUTE> - ANT. --- | | |
| | | | ANT. - <BASE_UNIT_RF_RX_ROUTE> - IC501(2/3 - 27) - C184 - Q161 - Q141 - D101 - L101/[L102-P101] - T/R (TEL LINE) | | |
| HANDSET SP-Phone RX | | | T/R (TEL LINE) - L101/[P101-L102] - D101 - Q141 - R165 - C173 - R178 - IC501(25 - 94/95) - <BASE_UNIT_RF_TX_ROUTE> - ANT | | |
| | | | --- ANT. - <HANDSET_RF_RX_ROUTE> - IC1(29/31) - Backside SP | | |
| BASE SP-Phone TX | | | MIC - C457/C458 - RA452 - IC501(37/38 - 27) - C184 - Q161 - Q141 - D101 - L101/[L102-P101] - T/R (TEL LINE) | | |
| BASE SP-Phone RX | | | T/R (TEL LINE) - L101/[P101-L102] - D101 - Q141 - R165 - C173 - R178 - IC501(25 - 41/43) - SPEAKER | | |
| CELLULAR TX | | | HANDSET MIC - R73/74 - C11/13 - RA4 - IC1(22/23) - <HANDSET_RF_TX_ROUTE> - ANT. --- | | |
| | | | ANT. - <BASE_UNIT_RF_RX_ROUTE> - IC501(2/3 - 80) - IC721(31 - 19) - R781 - ANT_BT - CELL PHONE | | |
| CELLULAR RX | | | CELL PHONE - ANT_BT - R781 - IC721(19 - 3) - IC501(81 - 94/95) - <BASE_UNIT_RF_TX_ROUTE> - ANT | | |
| | | | ---ANT.- <HANDSET_RF_RX_ROUTE> - IC1(28/27) - C86 - L74 - HEADSET JACK(5-4) - R11- HANDSET SPEAKER | | |
| Bluetooth Headset Sound TX(to Tel Line) | | | from BT Headset - ANT_BT - R781 - IC721(19 - 3) - IC501(81 - 27) - C184 - Q161 - Q141 - D101 - L101/[L102-P101] - T/R (TEL LINE) | | |
| Bluetooth Headset Sound RX(from Tel Line) | | | T/R (TEL LINE) - L101/[P101-L102] - D101 - Q141 - R165 - C173 - R178 - IC501(25 - 80) - IC721(31 - 19) - R781 - ANT_BT - to BT Headset | | |

Note:

: inside of Handset

RF part signal route

| SIGNAL ROUTE | IN | → | ROUTE | → | OUT |
|--------------------------------------|--|---|-------|---|-----|
| INTERCOM HANDSET TO BASE UNIT | HANDSET MIC - R73/74 - C11/13 - RA4 - IC1(22/23) - <HANDSET_RF_TX_ROUTE> - ANT. --- ANT - <BASE_UNIT_RF_RX_ROUTE> - IC501(2/3 - 41/43) - SPEAKER | | | | |
| INTERCOM BASE UNIT TO HANDSET | MIC - C457/C458 - RA452 - IC501(37/38 - 94/95) - <BASE_UNIT_RF_TX_ROUTE> - ANT --- ANT. - <HANDSET_RF_RX_ROUTE> - IC1(28/27) - C86 - L74 - HEADSET_JACK(5 - 4) - R11 - HANDSET SPEAKER | | | | |
| GREETING RECORDING | HANDSET MIC - R73/74 - C11/13 - RA4 - IC1(22/23) - <HANDSET_RF_TX_ROUTE> - ANT. --- ANT - <BASE_UNIT_RF_RX_ROUTE> - IC501(2/3 - 69/70) - IC601 | | | | |
| GREETING PLAY TO TEL LINE | IC601 - IC501(69/70 - 27) - C184 - Q161 - Q141 - D101 - L101/[L102-P101] - T/R (TEL LINE) | | | | |
| ICM RECORDING | T/R (TEL LINE) - L101/[P101-L102] - D101 - Q141 - R165 - C173 - R178 - IC501(25 - 69/70) - IC601 | | | | |
| ICM PLAY TO SPEAKER | IC601 - IC501(69/70 - 41/43) - SPEAKER | | | | |
| DTMF SIGNAL TO TEL LINE | IC501(27) - C184 - Q161 - Q141 - D101 - L101/[L102-P101] - T/R (TEL LINE) | | | | |
| CALLER ID | T/R(TEL LINE) - L101/[P101 - L102] - C105/C106 - R105/R106 - R108/R107 - IC501(23/21) | | | | |
| BELL DETECTION | T/R(TEL LINE) - L101 - C105 - R105 - R110 - R111 - R112 - IC501(18) | | | | |
| HANDSET RF [TX_ROUTE] | IC1(44/45) - L809 - C812 - DA801 - C895 - ANT | | | | |
| HANDSET RF [RX_ROUTE] | ANT - C895 - DA801 - C826 - IC1(46/47) | | | | |
| BASE UNIT RF [TX_ROUTE] | IC501(95/94) - L802/C813 - C812 - DA801 - C803 - DA802 - C851/C853 - ANT1/ANT2 | | | | |
| BASE UNIT RF [RX_ROUTE] | ANT1/ANT2 - C851/C853 - DA802 - C803 - DA801 - C826 - C854/C853 - IC501(3/2) | | | | |

Note:

: inside of Handset

5 Location of Controls and Components

Refer to the Operating Instructions.

Note:

You can download and refer to the Operating Instructions (Instruction book) on TSN Server.

6 Installation Instructions

Refer to the Operating Instructions.

Note:

You can download and refer to the Operating Instructions (Instruction book) on TSN Server.

7 Operating Instructions

Refer to the Operating Instructions.

Note:

You can download and refer to the Operating Instructions (Instruction book) on TSN Server.

8 Test Mode

8.1. Engineering Mode

8.1.1. Base Unit

Important:

Make sure the address on LCD is correct when entering new data. Otherwise, you may ruin the unit.

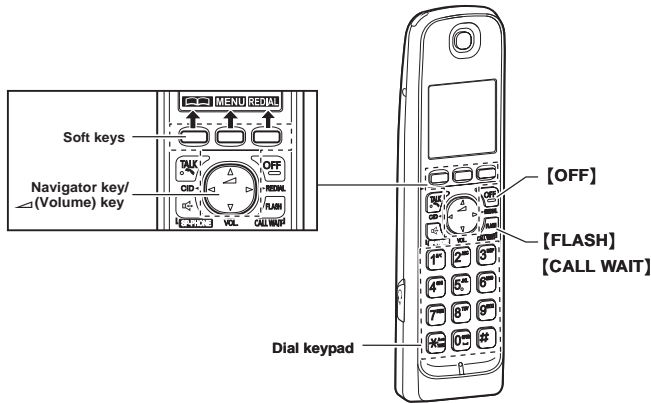

H/S key operation

- 1). Press **MENU** .
- 2). Select "Initial Setting" using **[▲]** or **[▼]** then press **SELECT** or **[▶]**.

 Select "Set tel line" using **[▲]** or **[▼]** then press **SELECT** or **[▶]**.
- 3). Enter "7", "2", "6", "2", "7", "6", "6", "4".
Note: 7262 7664 = PANA SONI
 (see letters printed on dial keys)
- 4). Select "Write EEP" using **[▲]** or **[▼]** then press **SELECT** or **[▶]**.
- 5). Enter "●", "●", "●", "●" (Address). (*1)
- 6). Enter "*", "*" (New Data). (*1)

H/S LCD

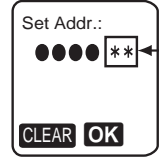
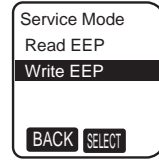
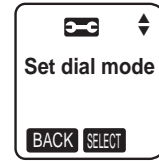
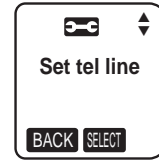
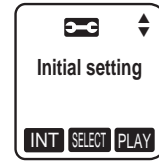

See next page

7). Press **OK** , a long confirmation beep will be heard.

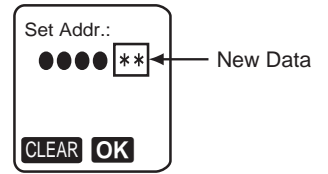

8). Press **[OFF]** to return to standby mode.
After that, turn the base unit power off and then power on.



Note: * To enter "Set dial mode", press **SELECT** or **[▶]** at " Set tel line".
It is necessary to turn on the power of base unit.

* "Set tel line" isn't appeared at Cell line only mode.
To back normal mode, execute the following procedure:

- 1 **[MENU]** → **[#][1][5][7]**
- 2 **[▼]/[▲]**: Select "off " → **[SELECT]**
- 3 **[OFF]**

Frequently Used Items (Base Unit)
ex.)

| Items | Address | Default Data | New Data | | Remarks |
|-----------|---------------|--------------|----------|---|---|
| Frequency | 00 07 / 00 08 | 70/02 | - | - | Use these items in a READ-ONLY mode to confirm the contents. Careless rewriting may cause serious damage to the computer system. |
| ID | 00 02 ~ 00 06 | Given value | - | - | |

Note:
(*1) When you enter the address or New Data, please refer to the table below.

| Desired Number (hex) | Input Keys | Desired Number (hex) | Input Keys |
|----------------------|------------|----------------------|-------------|
| 0 | 0 | A | [Flash] + 0 |
| 1 | 1 | B | [Flash] + 1 |
| . | . | C | [Flash] + 2 |
| . | . | D | [Flash] + 3 |
| . | . | E | [Flash] + 4 |
| 9 | 9 | F | [Flash] + 5 |

8.1.2. Handset

Important:

Make sure the address on LCD is correct when entering new data. Otherwise, you may ruin the unit.

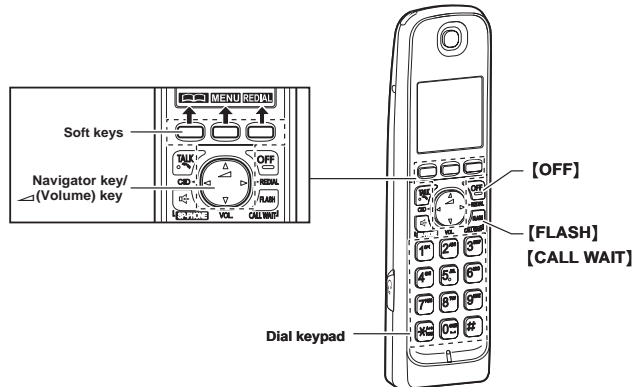

H/S key operation

- 1). Press **MENU** .
- 2). Select "Initial Setting" using **[▲]** or **[▼]** then press **SELECT** or **[▶]**.
- 3). Enter "7", "2", "6", "2", "7", "6", "6", "4".
Note: 7262 7664 = PANA SONI
 (see letters printed on dial keys)
- 4). Select "Write EEP" using **[▲]** or **[▼]** then press **SELECT** or **[▶]**.

H/S LCD

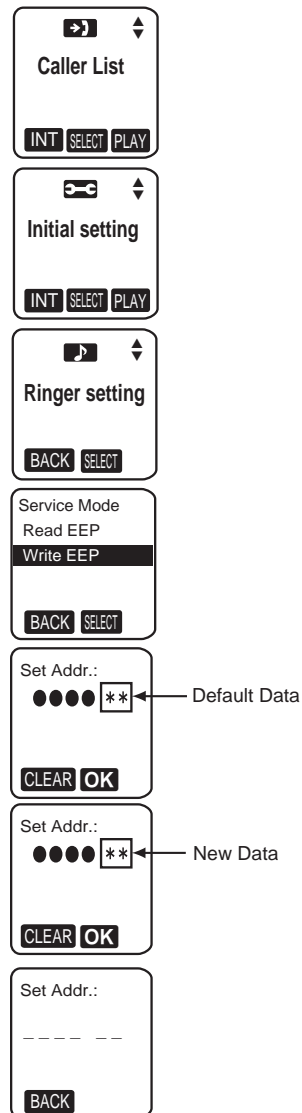

- 5). Enter "●", "●", "●", "●" (Address). (*1)
- 6). Enter "*", "*" (New Data). (*1)
- 7). Press **OK** , a long confirmation beep will be heard.
- 8). Press **[OFF]** to return to standby mode.

After that, remove and reinsert the batteries. Press the Power button for about 1 second if the power is not turned on.

Frequently Used Items (Handset)

ex.)

| Items | Address | Default Data | New Data | Possible Adjusted Value MAX (hex) | Possible Adjusted Value MIN (hex) | Remarks |
|-------------|---------------|--------------|----------|-----------------------------------|-----------------------------------|---------|
| Battery Low | 00 12/00 13 | 00 / 00 | - | - | - | (*2) |
| Frequency | 00 07 / 00 08 | 00 / 01 | - | - | - | |
| ID | 00 02 ~ 00 06 | Given value | - | - | - | |

Note:

(*1) When you enter the address or New Data, please refer to the table below.

| Desired Number (hex.) | Input Keys | Desired Number (hex.) | Input Keys |
|-----------------------|------------|-----------------------|-------------|
| 0 | 0 | A | [Flash] + 0 |
| 1 | 1 | B | [Flash] + 1 |
| . | . | C | [Flash] + 2 |
| . | . | D | [Flash] + 3 |
| . | . | E | [Flash] + 4 |
| 9 | 9 | F | [Flash] + 5 |

(*2) Use these items in a READ-ONLY mode to confirm the contents. Careless rewriting may cause serious damage to the handset.

9 Service Mode

9.1. How to Clear User Setting (Handset Only)

Handset

Press **2**, **5**, **8**, **0** simultaneously until a beep sound is heard. Then single handset is initialized.

(The contents of user setting are reset to factory default)

*Usage time is not cleared.

10 Troubleshooting Guide

10.1. Troubleshooting Flowchart

FLOW CHART

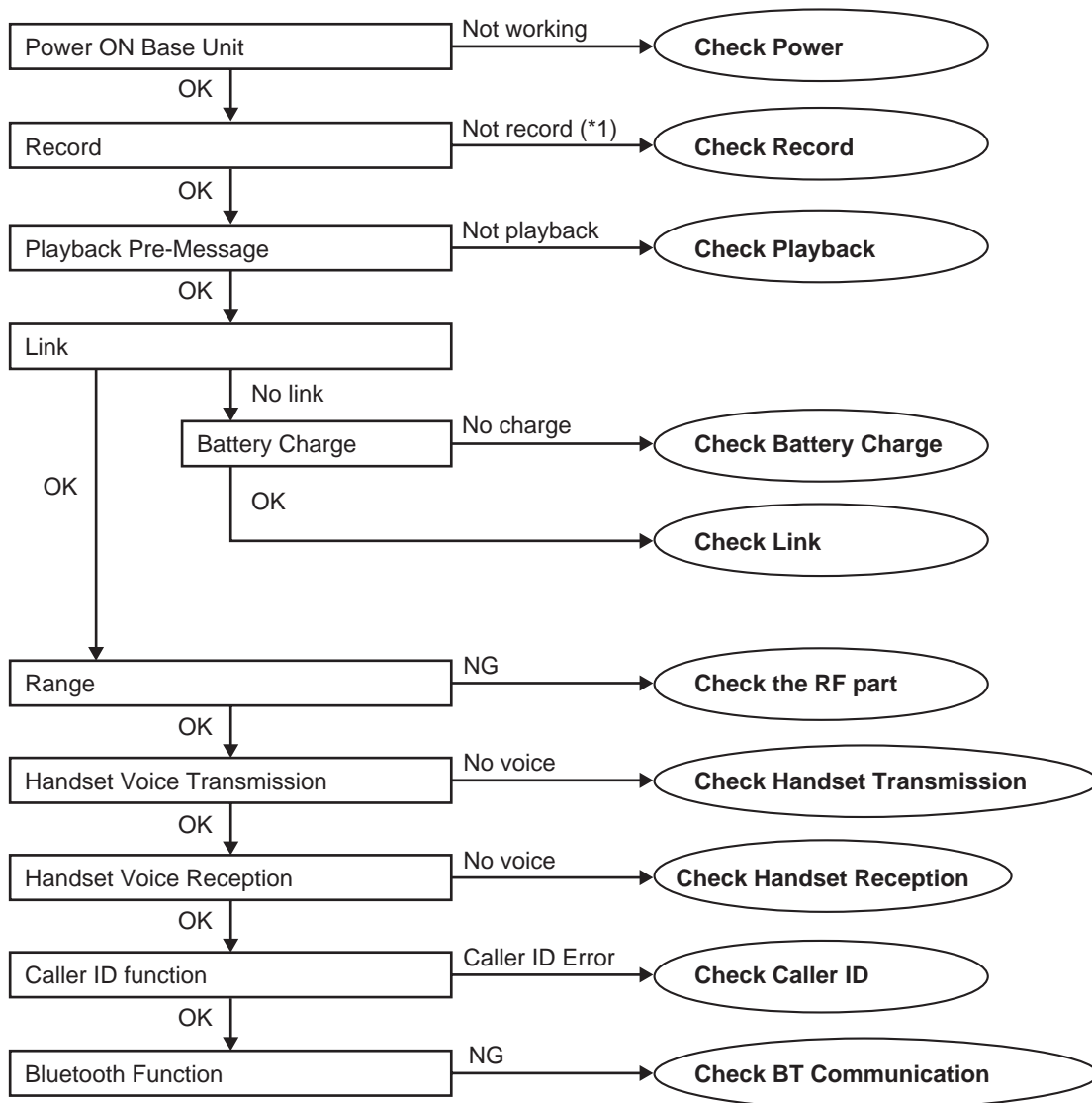

Cross Reference:

Check Power (P.34)

Check Record (P.35)

Check Playback (P.38)

Check Battery Charge (P.38)

Check Link (P.39)

Check the RF part (P.41)

Check Handset Transmission (P.46)

Check Handset Reception (P.46)

Check Caller ID (P.46)

Check BT Communication (P.47)

Note:

(*1) When a user claims that the unit disconnects a call right after the greeting message and no incoming messages can be recorded, this symptom can not be reappeared with TEL simulator in the service center. In this case, try to change the Auto disconnect activation time and Vox level.

<How to change the Auto Disconnect activation time and VOX level> (P.36) item (A) and (B).

10.1.1. Check Power

10.1.1.1. Base Unit

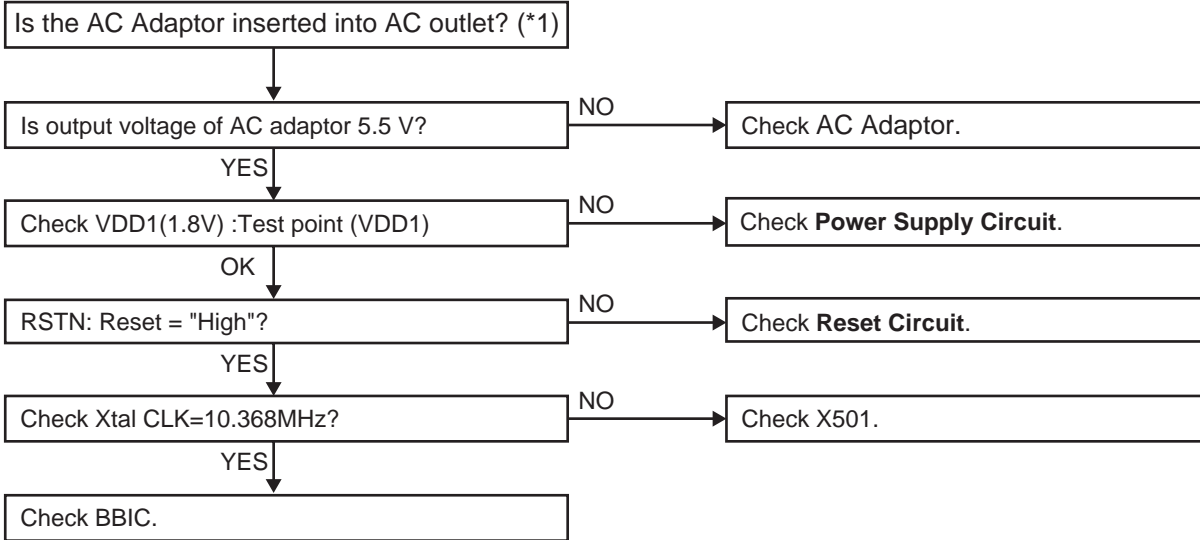

Cross Reference:
Power Supply Circuit/Reset Circuit (P.14)

Note:
 BBIC is IC501.
 (*1) Refer to **Specifications (P.6)** for part number and supply voltage of AC adaptor.
 (*2) Refer to **Circuit Board (Base Unit_Main) (P.85)**.

10.1.1.2. Handset

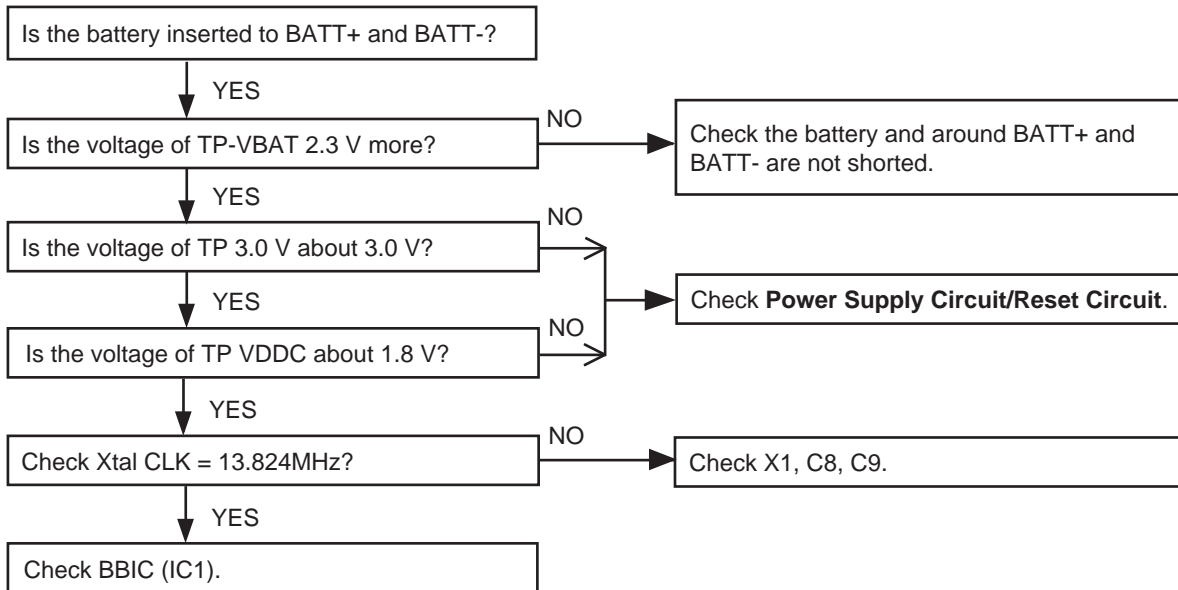

Cross Reference:
Power Supply Circuit/Reset Circuit (P.22)

10.1.2. Check Record

10.1.2.1. Base Unit

Not record Incoming Message

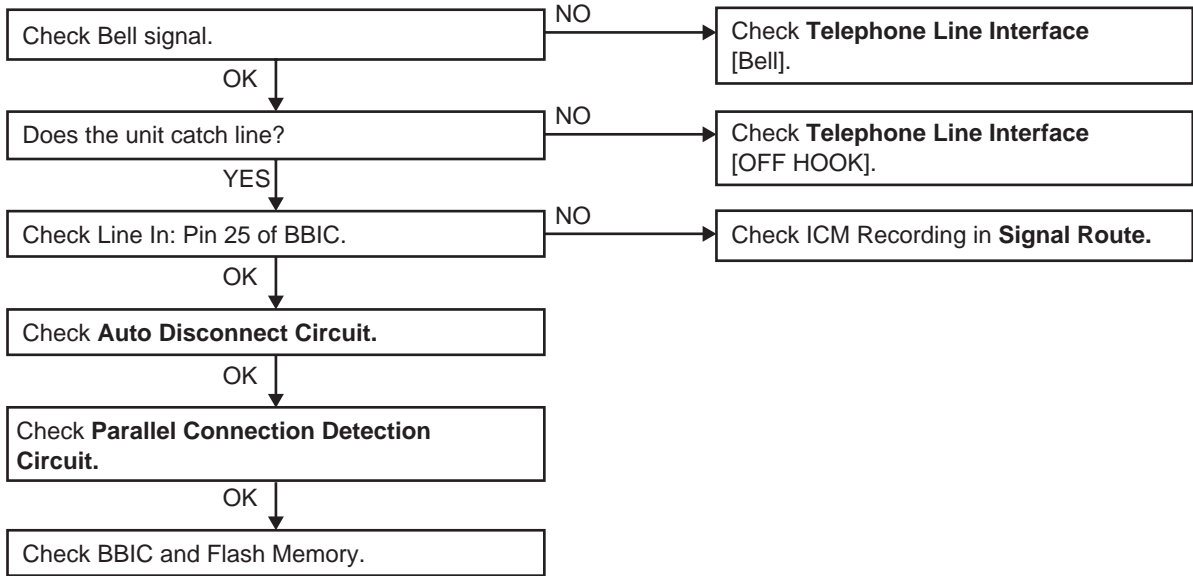

Cross Reference:

Signal Route (P.25)

Telephone Line Interface (P.16)

Parallel Connection Detect Circuit/Auto Disconnect Circuit (P.17)

Note:

Flash Memory is IC601.

BBIC is IC501.

<How to change the Auto Disconnect activation time and VOX level>

A) Auto Disconnect activation time:

Some Telephone Company lines (fiber or cable) ON Hook and OFF Hook voltages are lower than conventional lines, which may cause a malfunction of Auto Disconnect detection. To solve this problem, try changing the Auto Disconnect activation through the procedures below.

1) Press "MENU " key at standby Mode and "#" key.

Note: The set must power on and be linked.

2) Press "9", "0", "0", "0", "*" .

LCD (H/S)

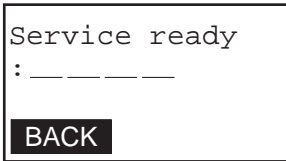

3) Press "7", "3", "1".

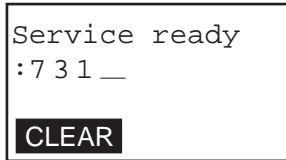

4) Then enter the below last digit;

| | | |
|------------|-----|--|
| last digit | "0" | Auto disconnect & CPC ^(*1) : enable . . . [default] |
| | "1" | Auto disconnect : enable ^(*1) CPC : disable |
| | "2" | Auto disconnect & CPC : disable ^(*2) |

Note:

(*1) Both Auto Disconnect and CPC don't detect for the first 2 seconds.

(*2) If the "Disable" is selected, even if the parallel-connected telephone is OFF HOOK, the line isn't disconnected.

5) Back to "standby" mode automatically after step 4).
You can hear beep sound which is a confirmation tone.

B) Vox level:

It makes easier to detect a small voice (caller) by raising the sensitivity of VOX level. Therefore, the recording of TAM is not turned off during a detection.

1) ~ 2) are same as (A).

3) Press "5", "1", "1".

| |
|---|
| Service ready :5 1 1 _ CLEAR |
|---|

4) Then enter the below last digit;

| | | |
|------------|-----|-----------------------------|
| last digit | "0" | default setting : normal |
| | "1" | 6dB up |

5) Back to "standby" mode automatically after step 4).
You can hear beep sound which is a confirmation tone.

10.1.3. Check Playback

10.1.3.1. Base Unit

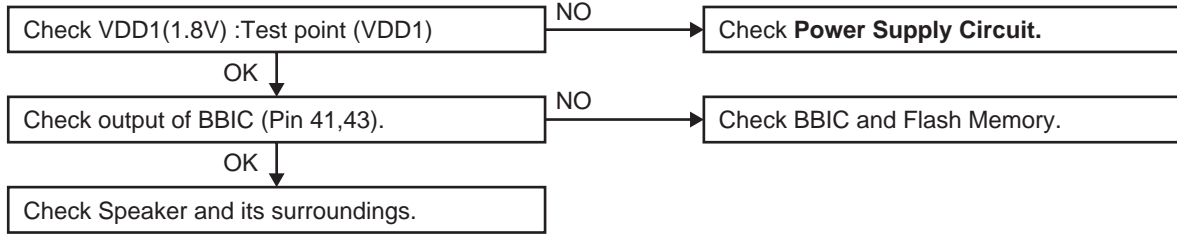

Cross Reference:
Power Supply Circuit/Reset Circuit (P.14)

Note:
 Flash Memory is IC601.
 BBIC is IC1.
 (*1) Refer to **Circuit Board (Base Unit_Main) (P.85)**.

10.1.4. Check Battery Charge

10.1.4.1. Base Unit

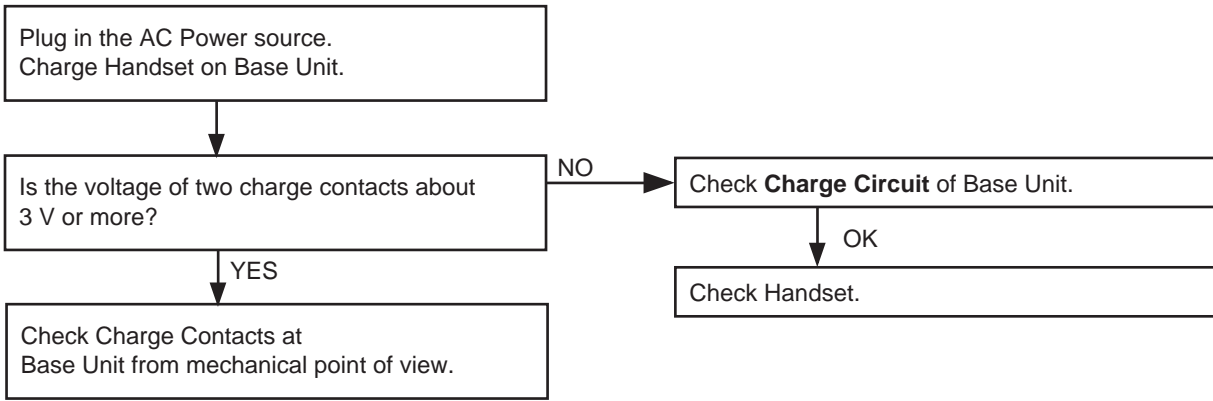

Cross Reference:
Charge Circuit (P.15)

10.1.4.2. Handset

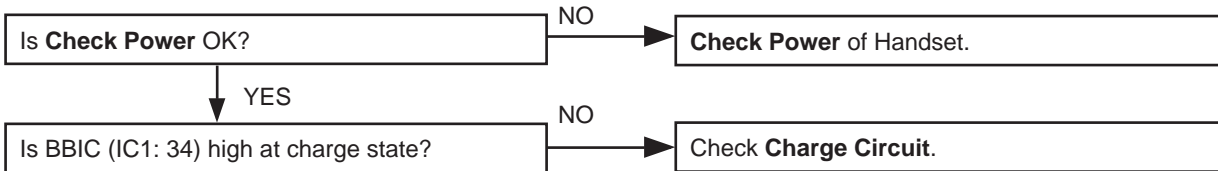

Cross Reference:
Check Power (P.34)
Charge Circuit (P.23)

10.1.4.3. Charger Unit

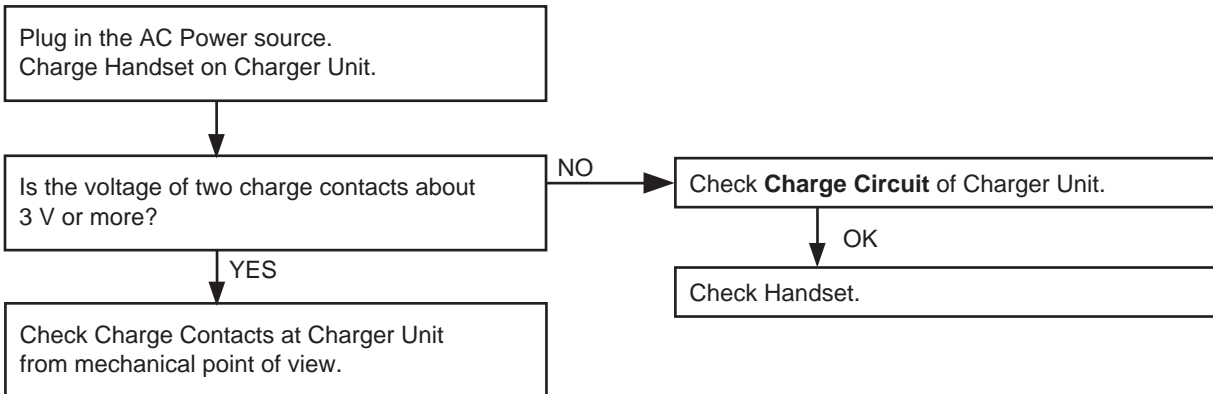

Cross Reference:
Charge Circuit (P.23)

10.1.5. Check Link

10.1.5.1. Base Unit

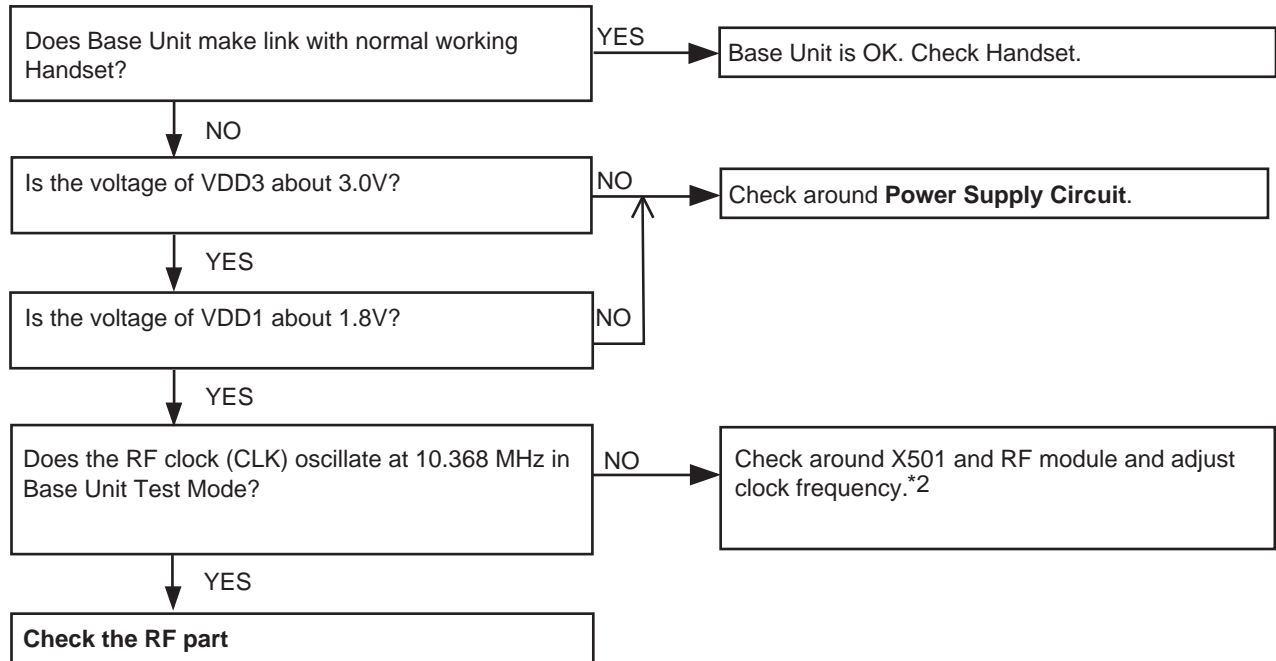

Cross Reference:

Power Supply Circuit/Reset Circuit (P.14)

Check the RF part (P.41)

Note:

*1 How to adjust +3.0V:

Execute the command "VDA"

Refer to **Things to Do after Replacing IC or X'tal (P.64)** for Base Unit.

*2 How to adjust the frequency of X501:

To see the frequency, execute the command "SFR", then check the TP_CKM (IC501-57pin).

To adjust frequency, send command "SFR □○○□○○" until the frequency counter becomes 13.824 MHz±55HZ.

10.1.5.2. Handset

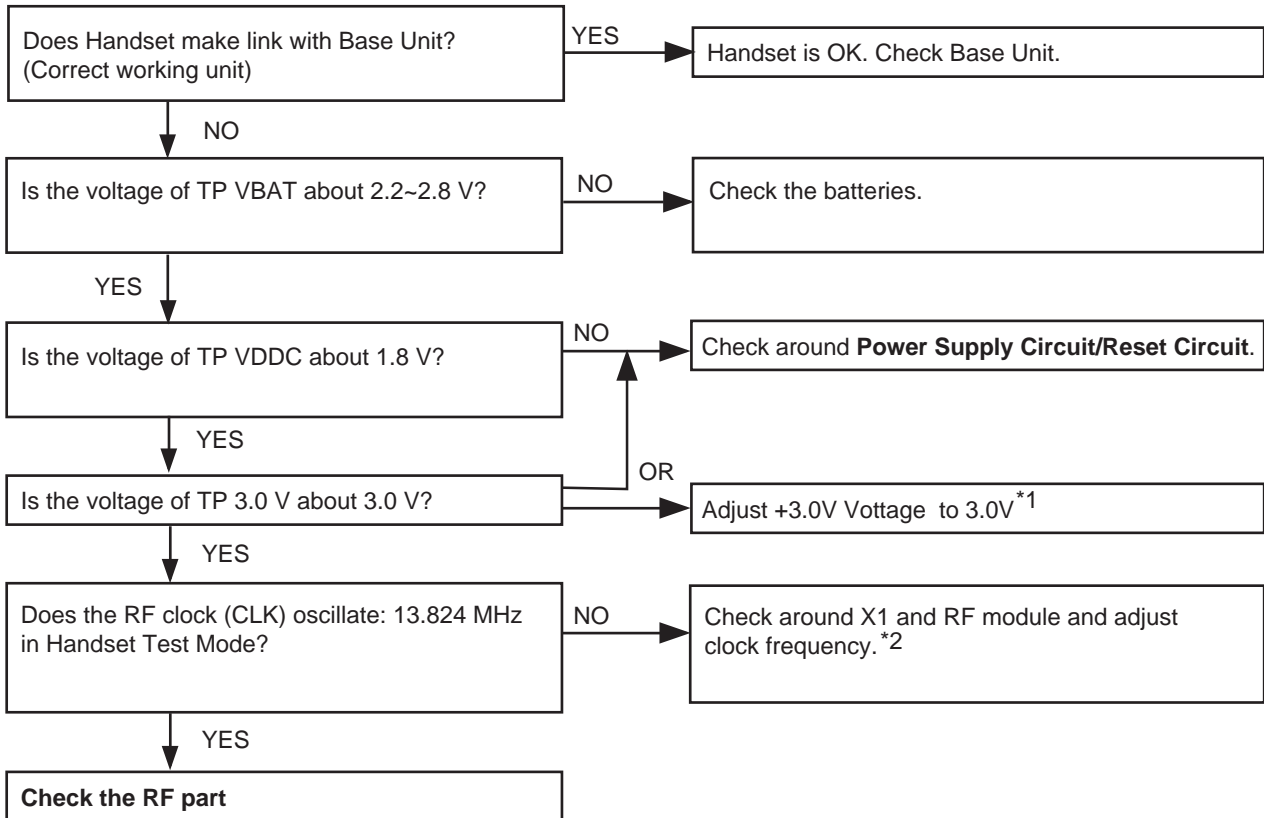

Cross Reference:

Power Supply Circuit/Reset Circuit (P.22)

Check the RF part (P.41)

Note:

*1 How to adjust +3.0V:

Execute the command "VDA"

Refer to **Things to Do after Replacing IC or X'tal (P.65)** for Handset.

*2 How to adjust the frequency of X1:

To see the frequency, execute the command "SFR", then check the TP_CKM (IC1-57pin).

To adjust frequency, send command "SFR □○○□○○"until the frequency counter becomes 13.824 MHz±55HZ.

10.1.6. Check the RF part

10.1.6.1. Finding out the Defective part

1. Prepare Regular HS(*1) and Regular BU(*2).
2. a. Re-register regular HS (Normal mode) to base unit (to be checked).
If this operation fails in some ways, the base unit is defective.
- b. Re-register handset (to be checked) to regular BU (Normal mode).
If this operation fails in some ways, the handset is defective.

After All the Checkings or Repairing

1. Re-register the checked handset to the checked base unit, and Regular HS to Regular BU.

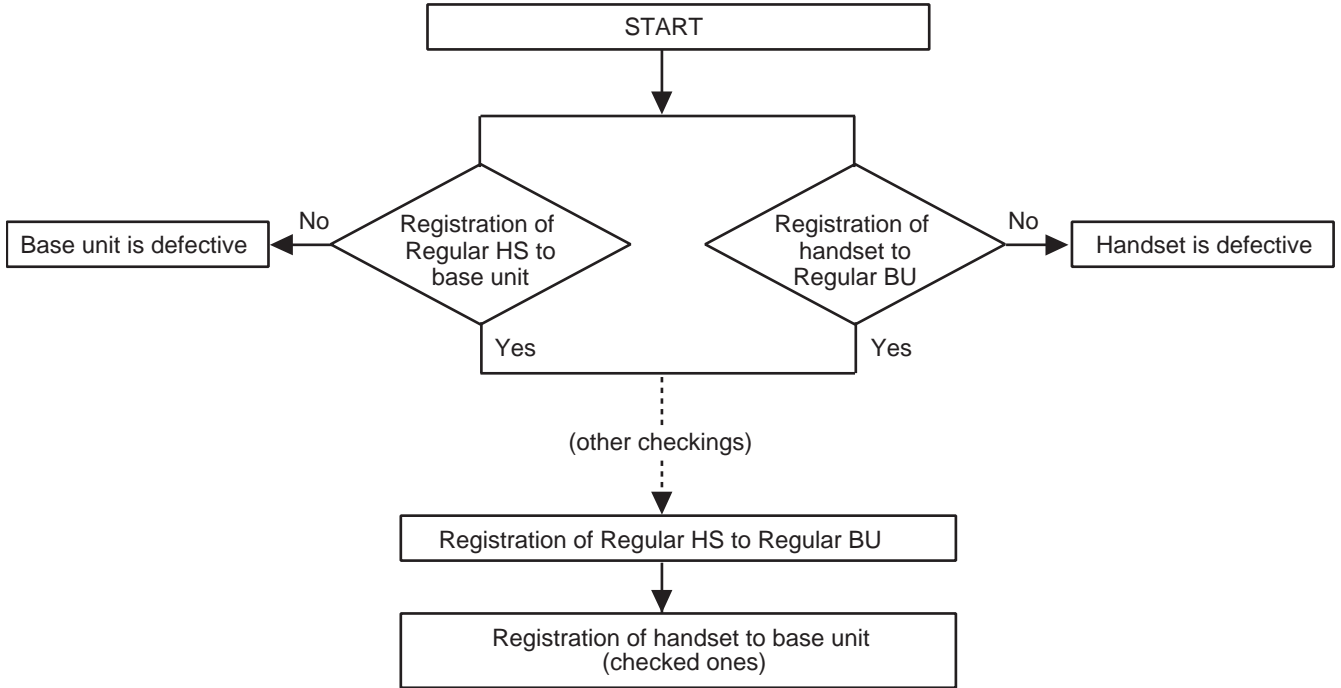

Note:

- (*1) HS: Handset
- (*2) BU: Base Unit

10.1.6.2. RF Check Flowchart

Each item (1 ~ 5) of RF Check Flowchart corresponds to **Check Table for RF part** (P.43).
Please refer to the each item.

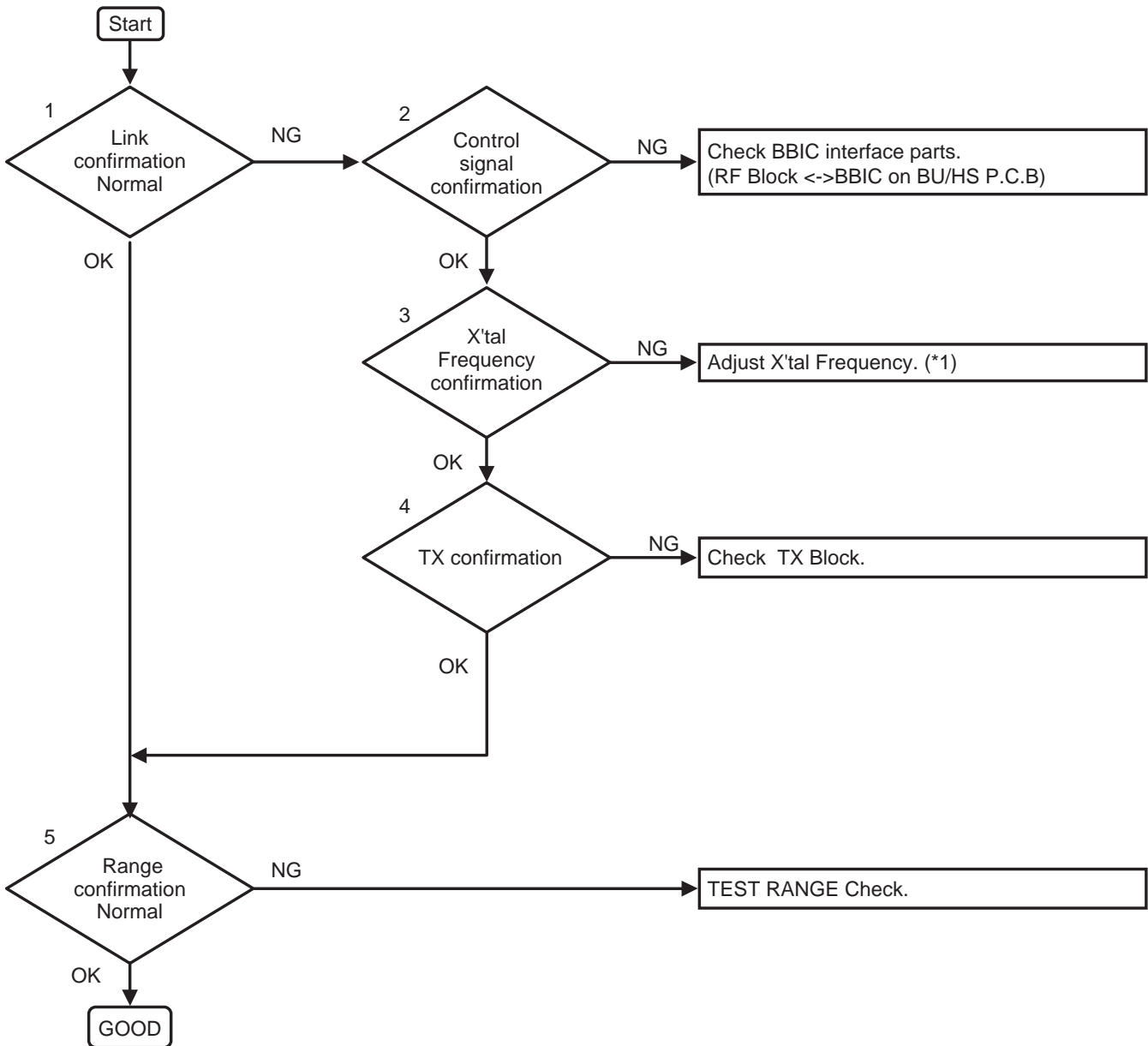

Note:
(*1) Refer to **Check Link** (P.39).

10.1.6.3. Check Table for RF part

| No. | Item | BU (Base Unit) Check | HS (Handset) Check |
|-----|---|--|--|
| 1 | Link Confirmation Normal HS, BU Mode [Normal Mode] | <ol style="list-style-type: none"> 1. Register Regular HS to BU (to be checked). 2. Press [Talk] key of the Regular HS to establish link. | <ol style="list-style-type: none"> 1. Register HS (to be checked) to Regular BU. 2. Press [Talk] key of the HS to establish link. |
| 2 | X'tal Frequency confirmation HS, BU Mode: [Adjustment] | Check X'tal Frequency. (10.368 MHz \pm 100Hz) | Check X'tal Frequency. (13.824 MHz \pm 100 Hz) |
| 3 | TX confirmation HS Mode: HS_Burst Mode] (*1) BS Mode: BS_Burst Mode] (*1) | <ol style="list-style-type: none"> 1. Remove wire antenna 2 and connect spectrum analyzer to TP. (*2) 2. Confirm TX power whether spec. is satisfied. Power \geq13.5dBm | <ol style="list-style-type: none"> 1. Connect spectrum analyzer to TP. (*3) 2. Confirm TX power whether satisfied spec. Power \geq16.0dBm |
| 4 | Range Confirmation Normal HS, BU Mode: [Normal Mode] | <ol style="list-style-type: none"> 1. Register Regular HS to BU (to be checked). 2. Press [Talk] key of the Regular HS to establish link. 3. Compare the range of the BU (being checked) with that of the Regular BU. | <ol style="list-style-type: none"> 1. Register HS (to be checked) to Regular BU. 2. Press [Talk] key of the HS to establish link. 3. Compare the range of the HS (being checked) with that of the Regular HS. |

Note:

(*1) Refer to **Commands** (P.60)

(*2) **Adjustment Standard (Base Unit)** (P.61)

(*3) **Adjustment Standard (Handset)** (P.63)

10.1.6.4. TEST RANGE Check

Circuit block which range is defective can be found by the following check.

| Item | BU (Base Unit) Check | HS (Handset) Check |
|---|--|--|
| Range Confirmation TX TEST (TX Power check) HS, BU setting Checked unit: Low TX power (*1) Regular unit: High TX power (*1) | 1. Register Regular HS to BU (to be checked). 2. Set TX Power of the BU and the Regular HS according to CHART1. 3. At distance of about 20m between HS and BU, Link OK = TX Power of the BU is OK. No Link = TX Power of the BU is NG. | 1. Register HS (to be checked) to Regular BU. 2. Set TX Power of the HS and the Regular BU according to CHART1. 3. At distance of about 20m between HS and BU, Link OK = TX Power of the HS is OK. No Link = TX Power of the HS is NG. |
| Range Confirmation RX TEST (RX sensitivity check) HS, BU setting Checked unit: High TX power (*1) Regular unit: Low TX power (*1) | 1. Register Regular HS to BU (to be checked). 2. Set TX Power of the BU and the Regular HS according to CHART1. 3. At distance of about 20m between HS and BU, Link OK= RX Sensitivity of the BU is OK. No Link = RX Sensitivity of the BU is NG. | 1. Register HS (to be checked) to Regular BU. 2. Set TX Power of the Checking HS and the Regular BU according to CHART1. 3. At distance of about 20m between HS and BU, Link OK= RX Sensitivity of the HS is OK. No Link = RX Sensitivity of the HS is NG |

CHART1: Setting of TX Power and RX Sensitivity in Range Confirmation TX TEST, RX TEST

| | BU (to be checked) | Regular_HS |
|-------------------------------------|--------------------|------------|
| | TX Power | TX Power |
| BU (Base Unit) TX Power Check | Low | High |
| BU (Base Unit) RX Sensitivity Check | High | Low |

| | HS (to be checked) | Regular_BU |
|-----------------------------------|--------------------|------------|
| | TX Power | TX Power |
| HS (Handset) TX Power Check | Low | High |
| HS (Handset) RX Sensitivity Check | High | Low |

Note:

(*1) Refer to **Commands** (P.60).

10.1.7. Registering a Handset to the Base Unit

The supplied handset and base unit are pre-registered. If for some reason the handset is not registered to the base unit, re-register the handset.

- 1 **Handset:**
[MENU] → **# 1 3 0**
- 2 **Base unit:**
 Press and hold **MLOCATOR** for about 5 seconds until the registration tone sounds.
 - If all registered handsets start ringing, press **[LOCATOR]** again to stop, then repeat this step.
 - The next step must be completed within 90 seconds.
- 3 **Handset:**
 Press **[OK]**, then wait until a long beep sounds.

Note:

- While registering, “**Base in registering**” is displayed on all registered handsets.
- When you purchase an additional handset, refer to the additional handset’s installation manual for registration.

10.1.8. Deregistering a Handset

A handset can cancel its own registration to the base unit, or other handsets registered to the same base unit. This allows the handset to end its wireless connection with the system.

- 1 **[MENU]** → **# 1 3 1**
 - All handsets registered to the base unit are displayed.
- 2 **[↕]**: Select the handset you want to cancel. → **[SELECT]**
- 3 **[↕]**: “Yes” → **[SELECT]**
- 4 **[OFF]**

10.1.9. Check Handset Transmission

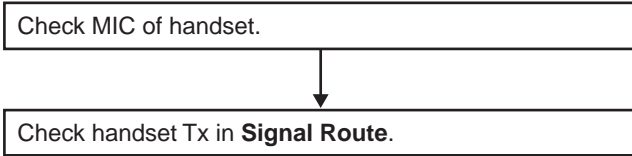

Cross Reference:
Signal Route (P.25)

10.1.10. Check Handset Reception

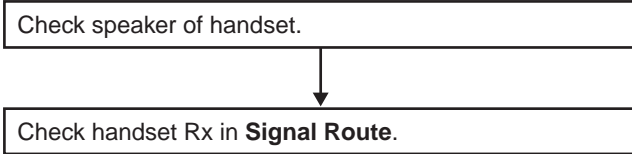

Cross Reference:
Signal Route (P.25)

Note:
When checking the RF part, Refer to **Check the RF part** (P.41).

10.1.11. Check Caller ID

BASE UNIT

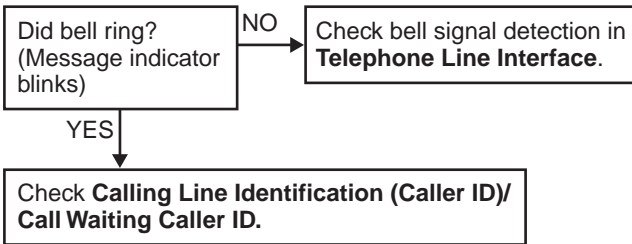

Cross Reference:
Telephone Line Interface (P.16)
Calling Line Identification (Caller ID)/Call Waiting Caller ID (P.18)

Note:

- Make sure the format of the Caller ID service of the Telephone company that the customer subscribes to.
- It is also recommended to confirm that the customer is really a subscriber of the service.

10.1.12. Check BT Communication

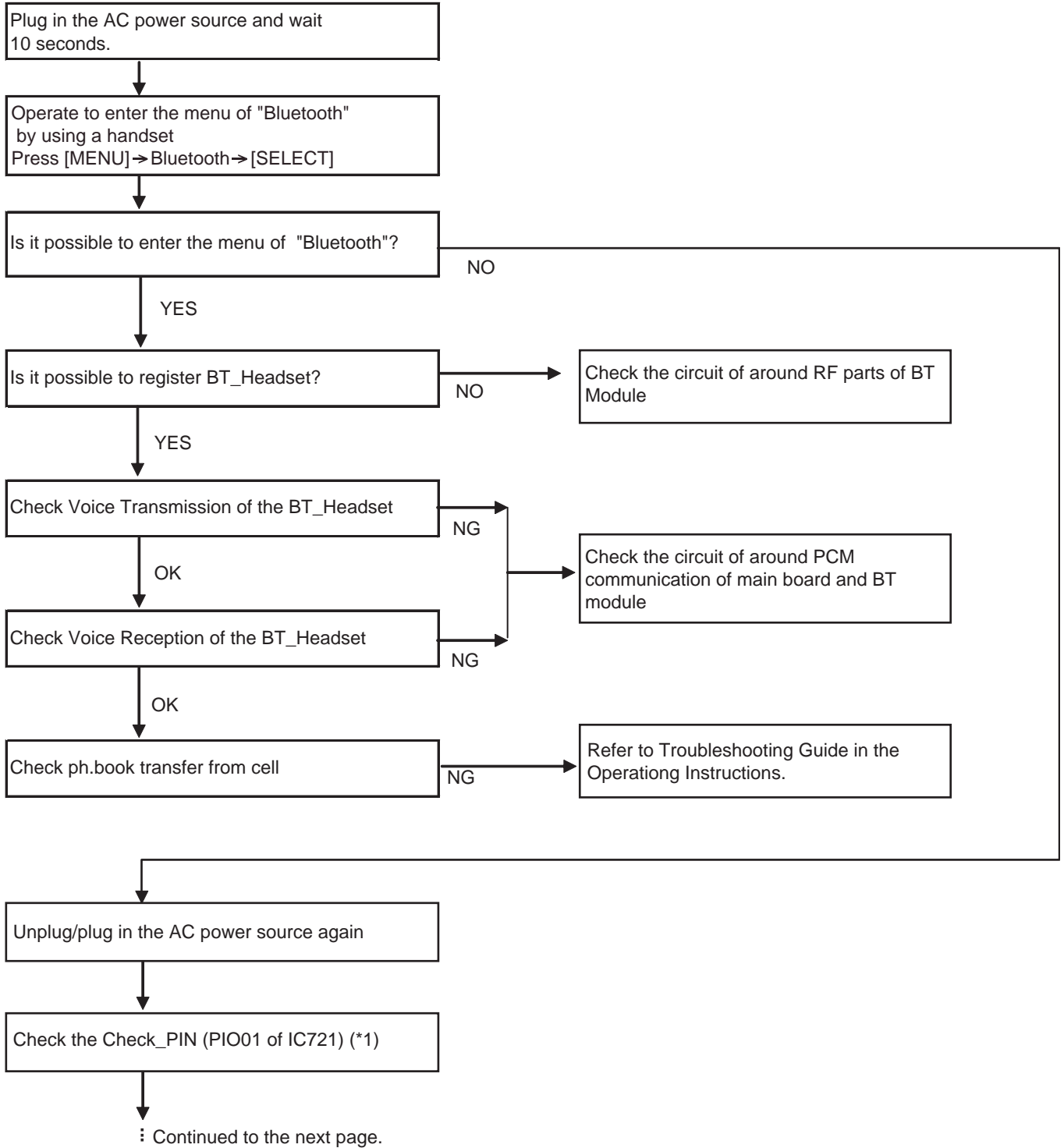

Cross Reference:
Bottom View (P.86)

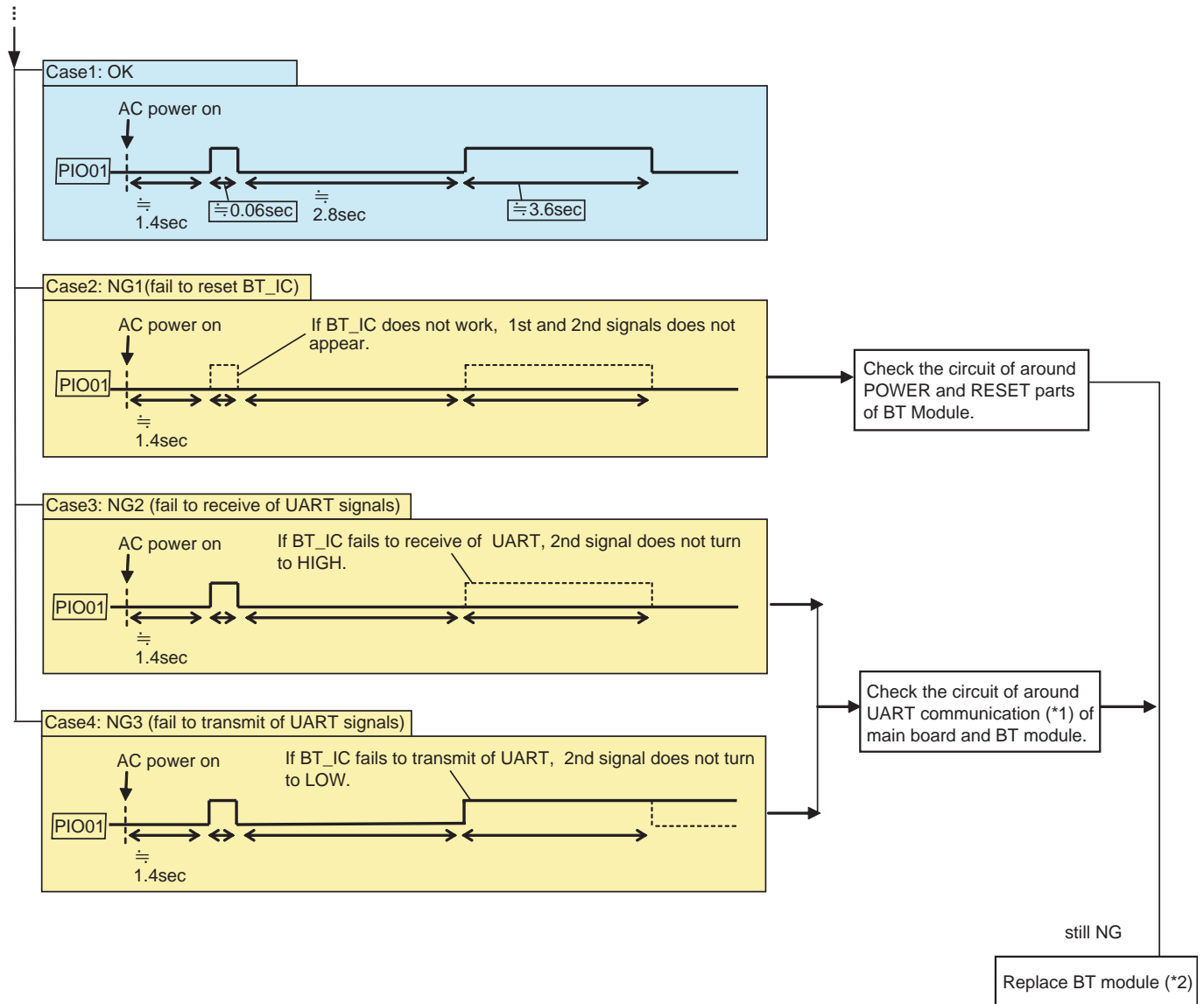

Cross Reference:

Schematic Diagram (Base Unit_RF) (P.76)

Note:

(*2) After replacing, need to adjust the frequency of BT.
Refer to **Things to Do after Replacing IC or X'tal** (P.64)

11 Disassembly and Assembly Instructions

11.1. Disassembly Instructions

11.1.1. Base Unit

- ① Remove the 5 screws to remove the cabinet cover.
- ② Remove the solders.

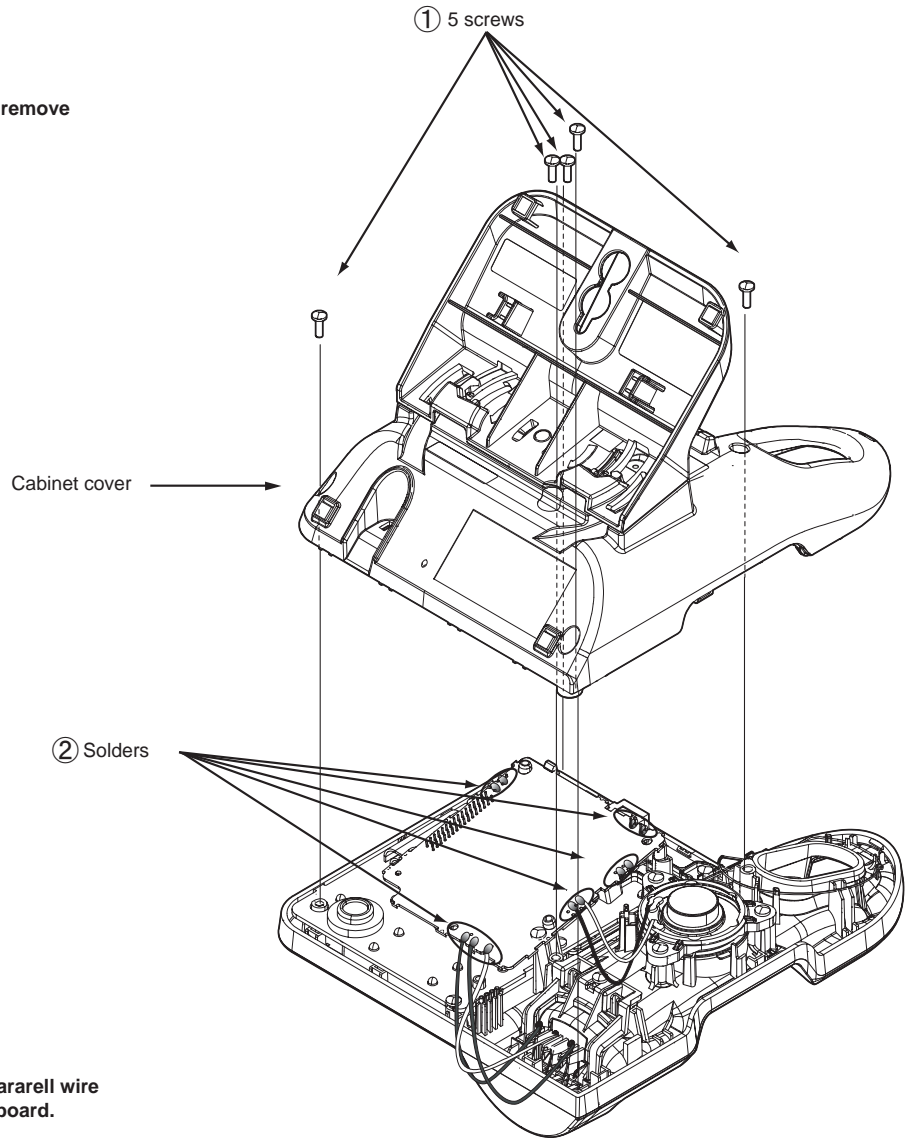

- ③ Remove the screw and parrell wire to remove the main P.C. board.

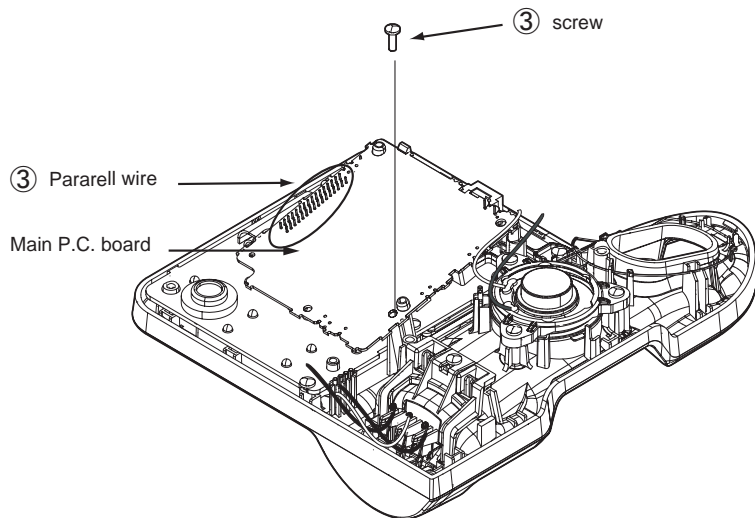

- ④ Remove the screw to remove the Jack holder.

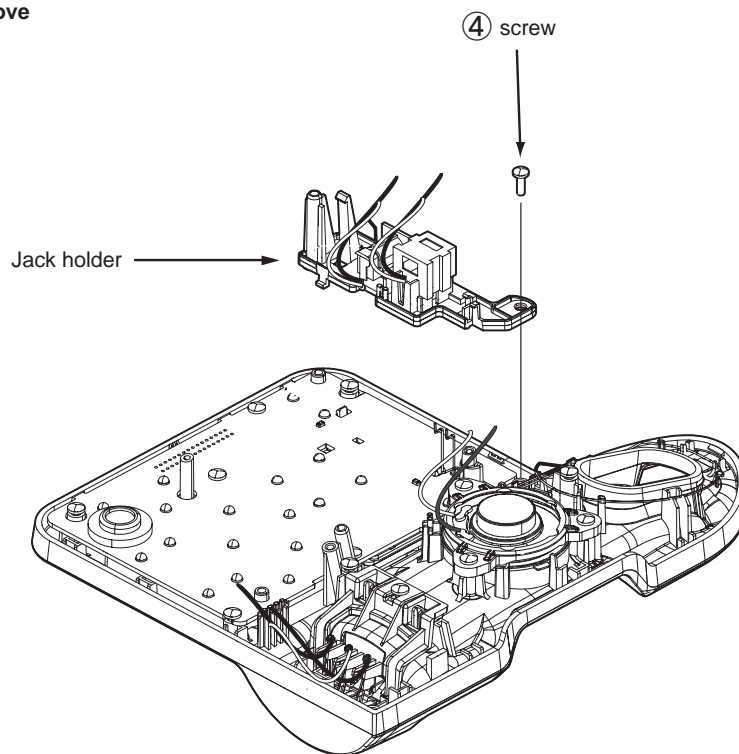

- ⑤ Remove the 4 screws and parrell wire to remove the operational P.C.B board.

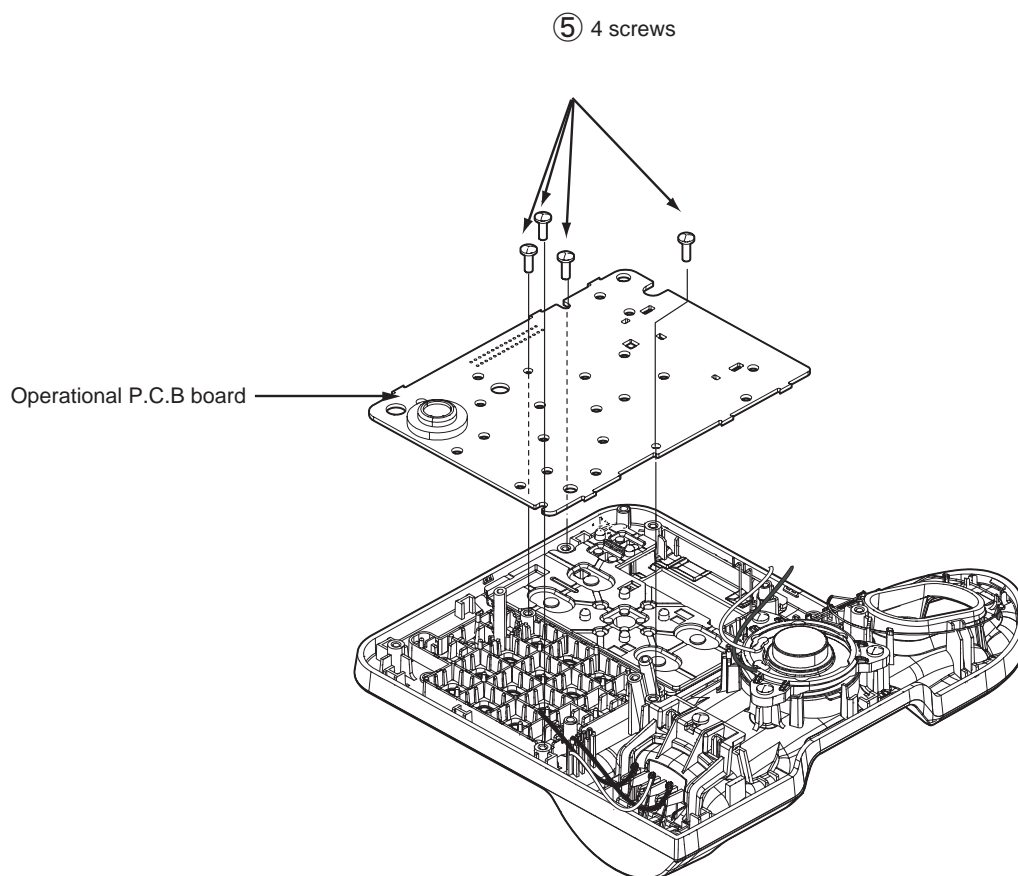

11.1.2. Handset

- ① Remove the 2 screws.

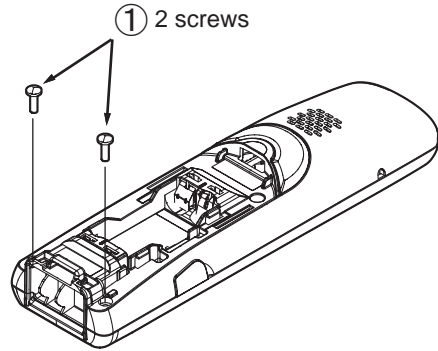

- ② Insert a plastic card. (Ex. Used SIM card etc.) between the cabinet body and the cabinet cover, then pull it along the gap to open the cabinet.

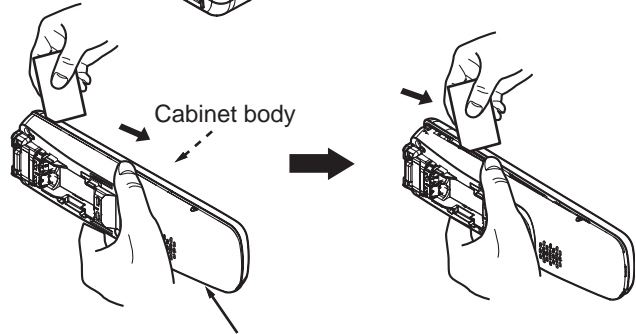

- ③ Likewise, open the other side of the cabinet.

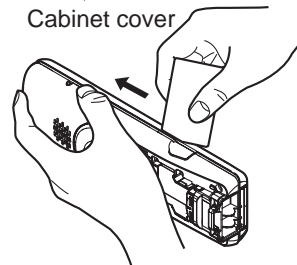

- ④ Remove the cabinet cover by pushing it upward.

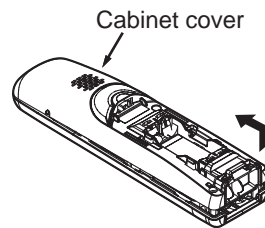

- ⑤ Remove the solders and tape.

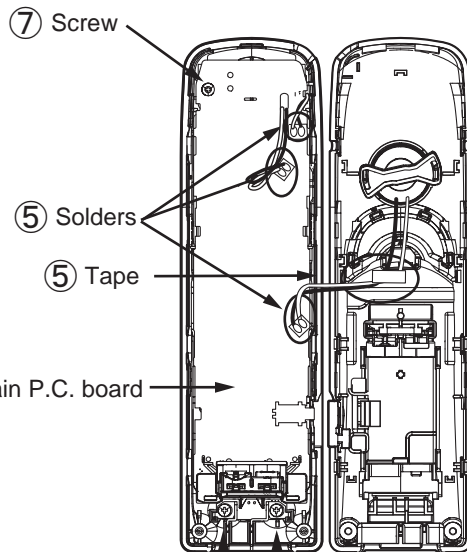

- ⑥ Remove the 2 screws to remove the 2 charge terminals.

- ⑦ Remove the screw to remove the main P. C. board.

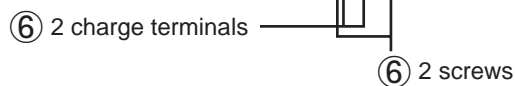

11.1.3. Charger Unit

- ① Remove the screw to remove the cabinet cover.

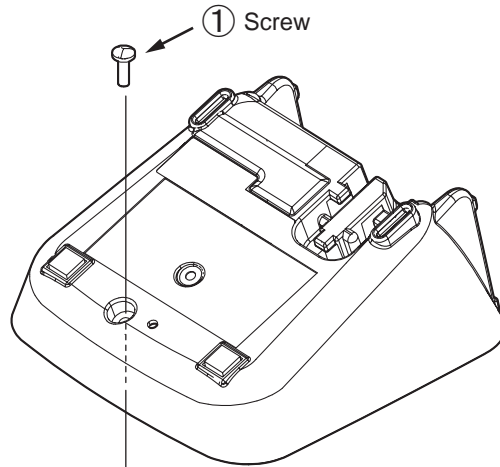

- ② Remove the solders to remove the 2 charge terminals.

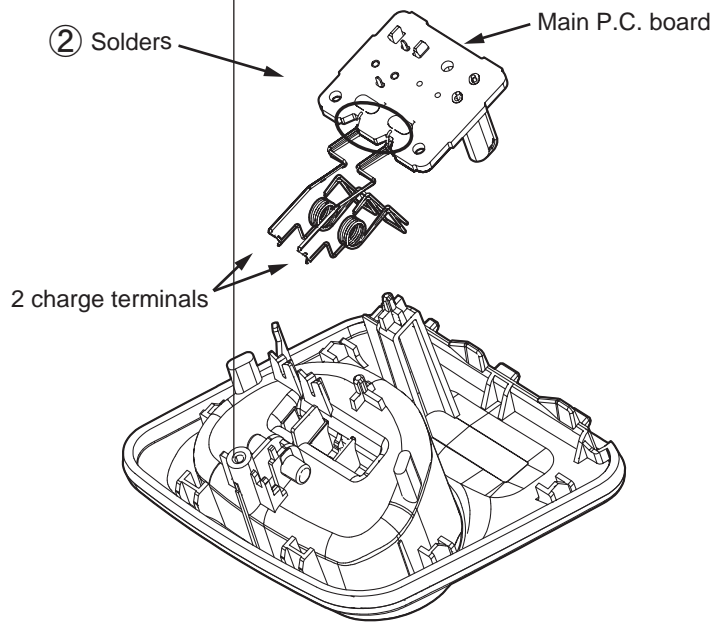

11.2. How to Attach the Antenna

Locate as the following figure

- ① Fix by hook.
- ② Insert to boss

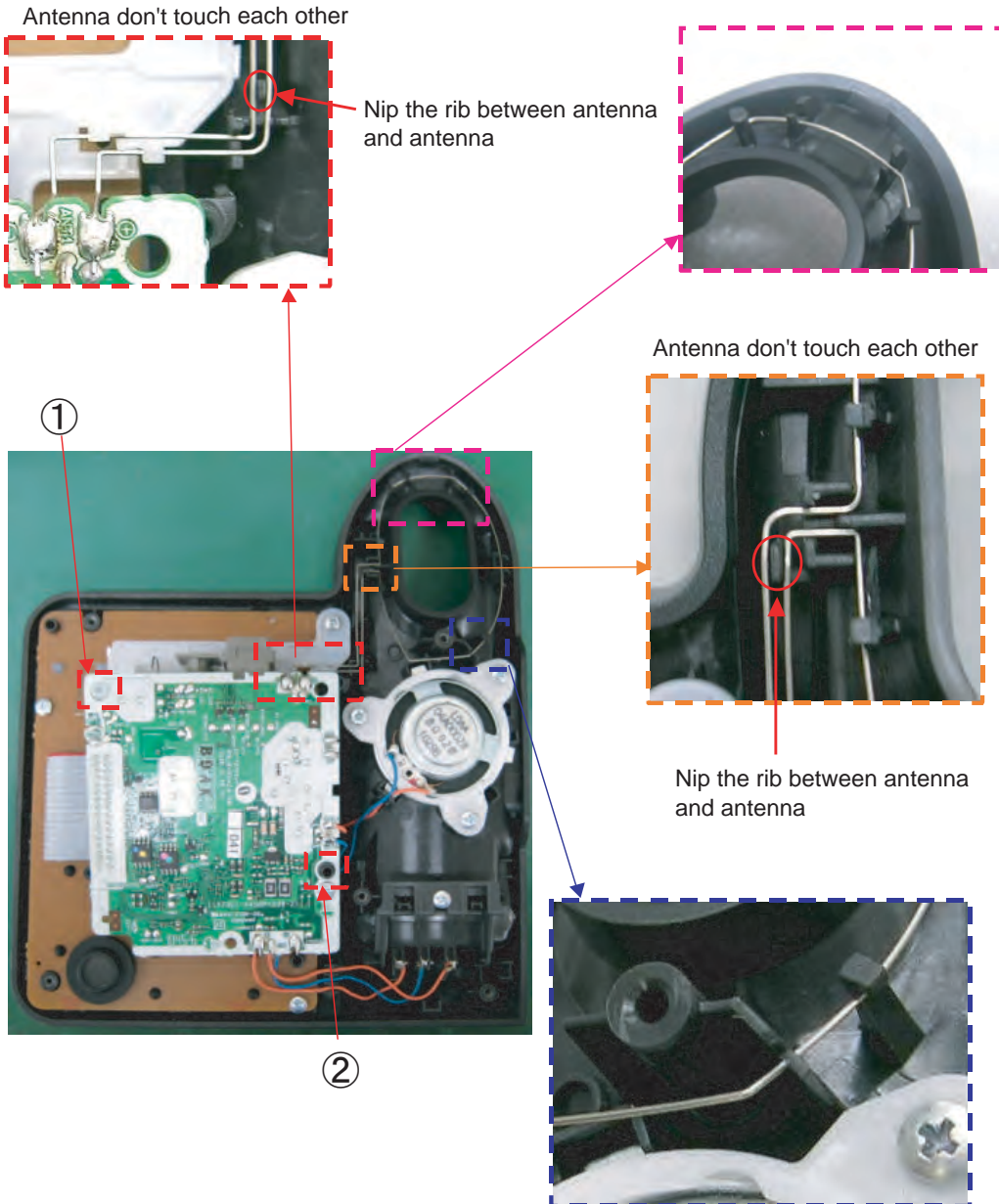

11.3. How to Replace the Base unit LCD

- ① Fit the heatseal of a new LCD.

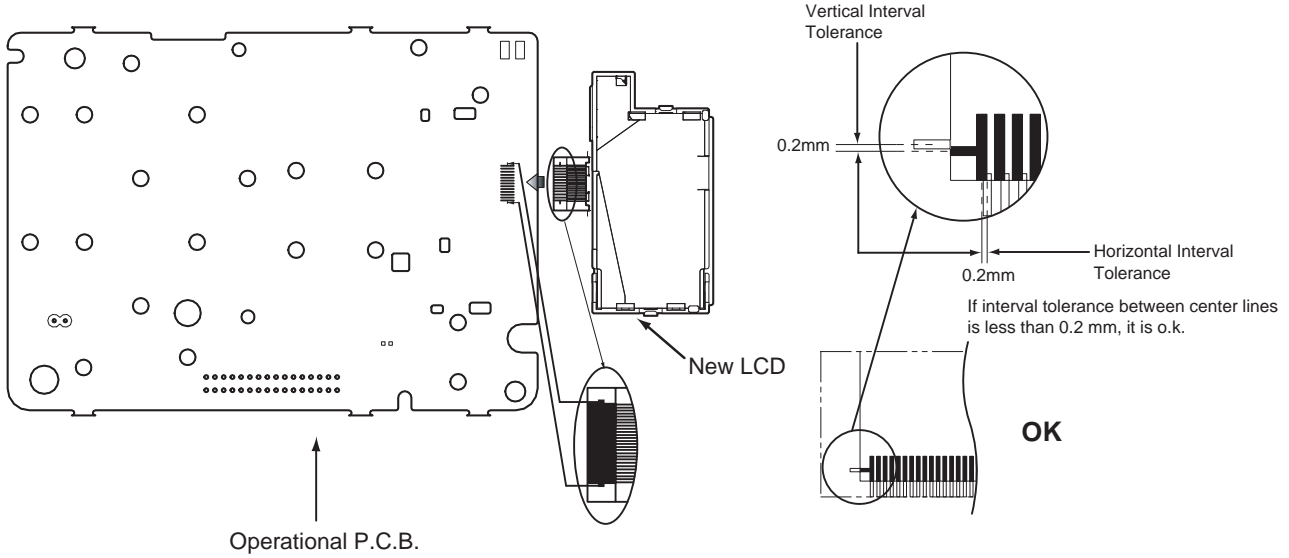

- ② Heatweld with the tip of the soldering iron about 5 to 8 seconds (in case of 60W soldering iron).

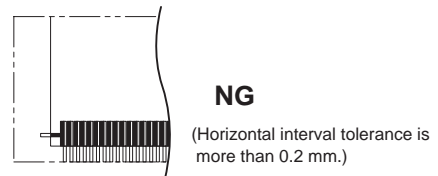
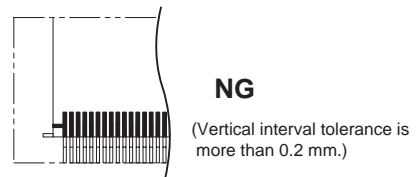
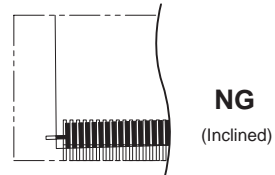
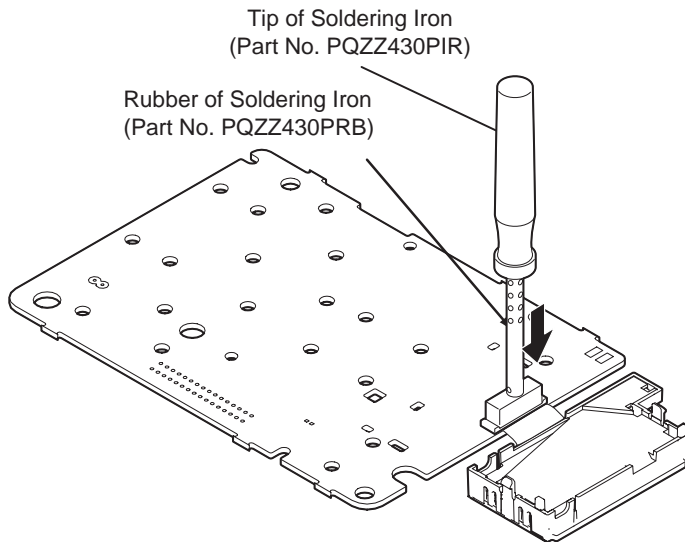

③ Attach the LCD and fix by hook A (two points).

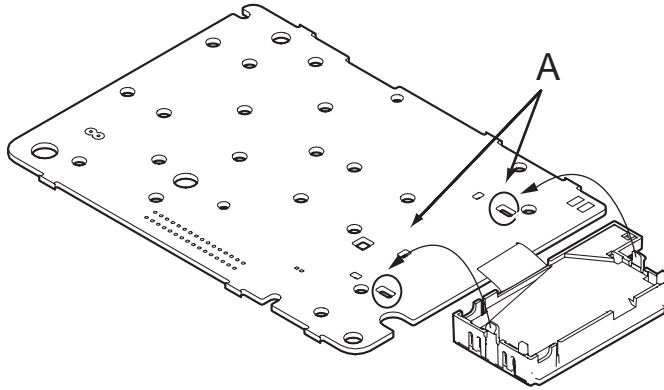

④ Solder the wires.

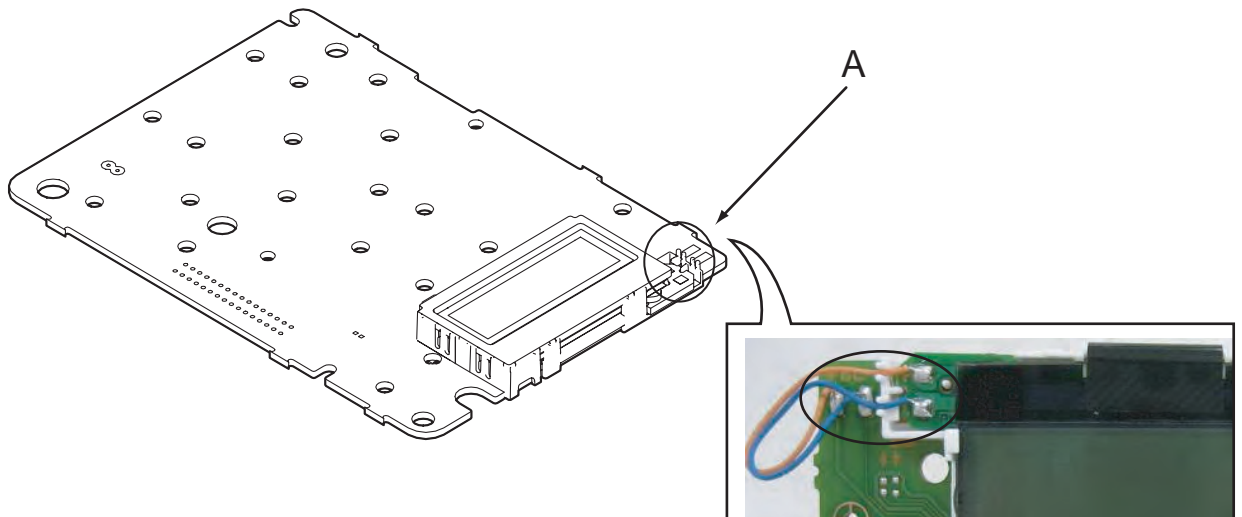

11.4. How to Replace the Handset LCD

Note:

The illustrations are simplified in this page.
They may differ from the actual product.

①

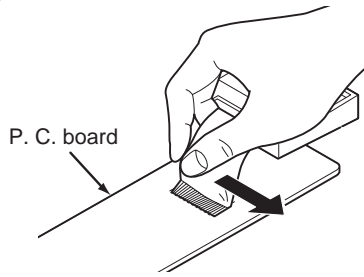

Peel off the FFC (Flexible Flat Cable) from the LCD, in the direction of the arrow. Take care to ensure that the foil on the P.C. board is not damaged.

②

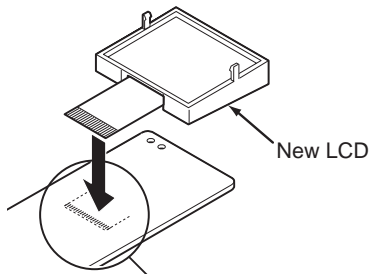

Fit the heatseal of a new LCD.

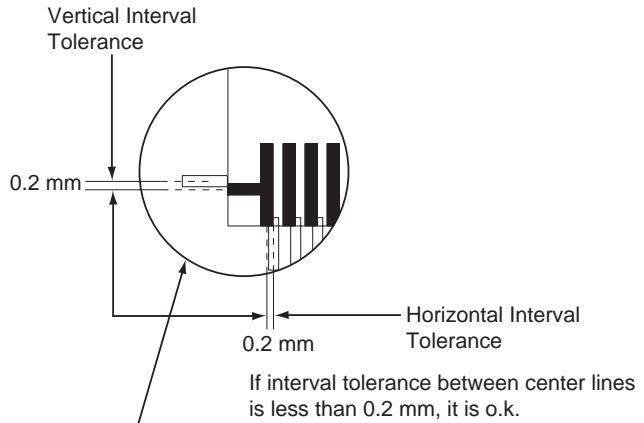

③

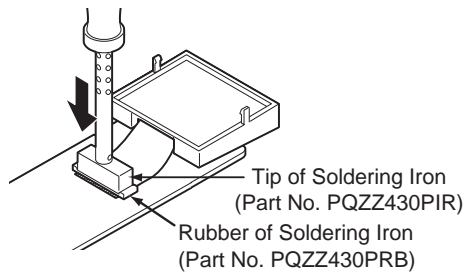

Heatweld with the tip of the soldering iron about 5 to 8 seconds (in case of 60W soldering iron).

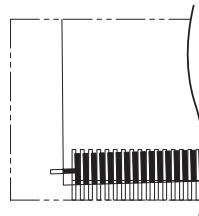

OK

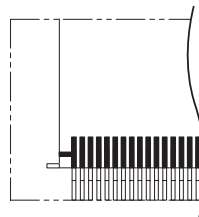

NG

(Inclined)

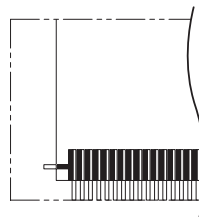

NG

(Vertical interval tolerance is more than 0.2 mm.)



NG

(Horizontal interval tolerance is more than 0.2 mm.)

12 Measurements and Adjustments

This chapter explains the measuring equipment, the JIG connection, and the PC setting method necessary for the measurement in **Troubleshooting Guide** (P.33)

12.1. Equipment Required

- Digital multi-meter (DMM): it must be able to measure voltage and current.
- Oscilloscope.
- Frequency counter: It must be precise enough to measure intervals of 1 Hz (precision; ± 4 ppm)
Hewlett Packard, 53131A is recommended.
- DECT tester: Rohde & Schwarz, CMD 60 is recommended.
This equipment may be useful in order to precisely adjust like a mass production.

12.2. The Setting Method of JIG

<Preparation>

- Serial JIG cable: PQZZ1CD300E*
- PC which runs in DOS mode
- **Batch file CD-ROM** for setting: PNZZTG7621M

Note:

*: If you have the JIG Cable for TCD500 series (PQZZ1CD505E), change the following values of resistance. Then you can use it as a JIG Cable for both TCD300 and TCD500 series. (It is an upper compatible JIG Cable.)

| Resistor | Old value (k Ω) | New value (k Ω) |
|----------|-------------------------|-------------------------|
| R2 | 22 | 3.3 |
| R3 | 22 | 3.3 |
| R4 | 22 | 4.7 |
| R7 | 4.7 | 10 |

12.2.1. Connections (Base Unit)

- ① Connect the AC adaptor.
- ② Connect the JIG Cable GND (black).
- ③ Connect the JIG Cable RX (red) and TX (yellow).

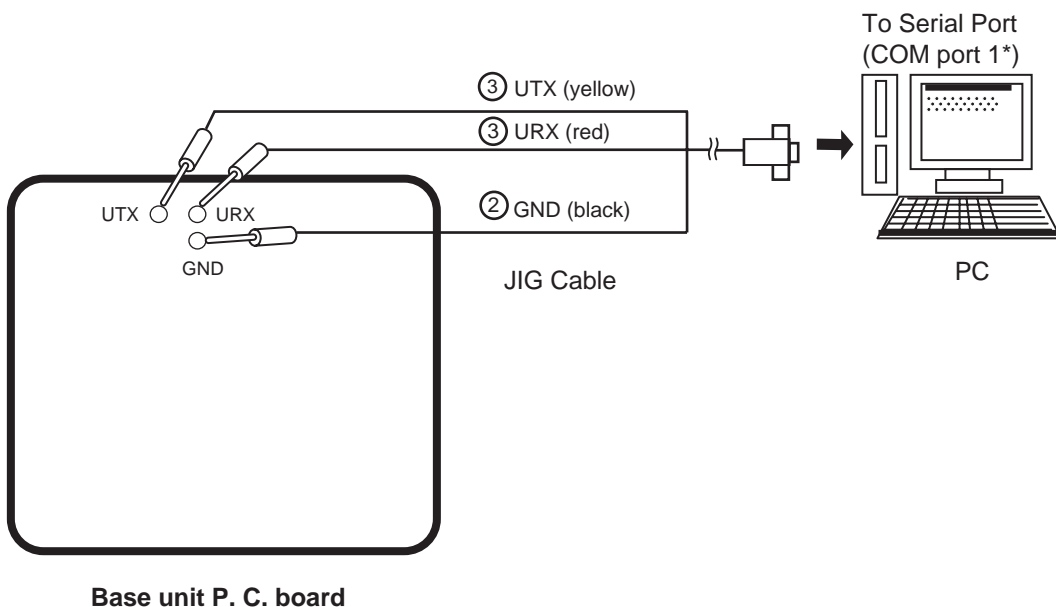

Note:

*: COM port names may vary depending on what your PC calls it.

12.2.2. Connections (Handset)

- ① Connect the DC Power or Battery to BATT+ and BATT-.
- ② Connect the JIG cable GND (black) to GND.
- ③ Connect the JIG cable UTX (yellow) to UTX and URX (red) to URX.

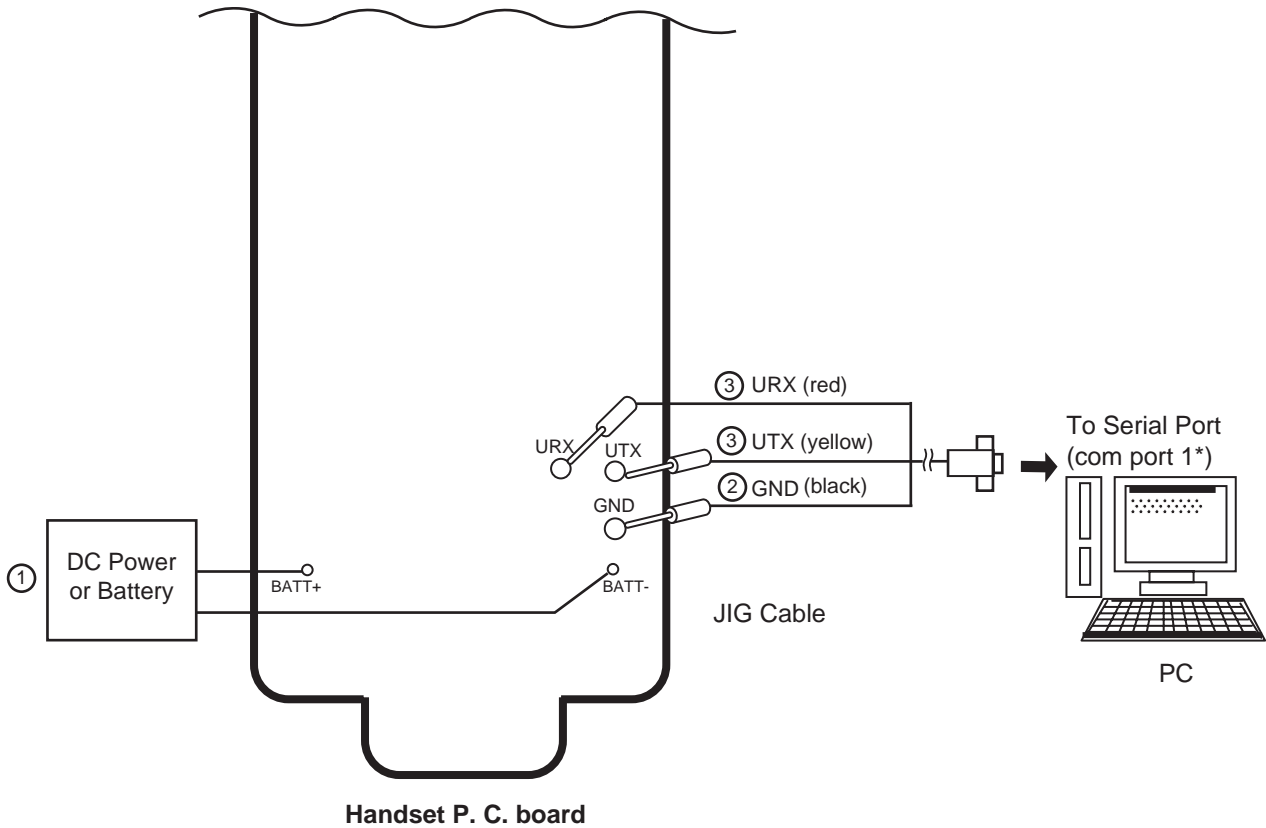

Note:

*: COM port names may vary depending on what your PC calls it.

12.2.3. How to install Batch file into P.C.

1. Insert the Batch file CD-ROM into CD-ROM drive and copy PNZZTG**** folder to your PC (example: D drive).

2. Open an MS-DOS mode window.

3. At the DOS prompt, type "D:" (for example) to select the drive, then press the **Enter** key.

4. Type "CD ¥PNZZTG****", then press the **Enter** key.

5. Type "SET_COM=X", then press the **Enter** key (X: COM port number used for the serial connection on your PC).

6. Type "READID", then press the **Enter** key.
 • If any error messages appear, change the port number or check the cable connection.
 • If any value appear, go to next step.

7. Type "DOSKEY", then press the **Enter** key.

<Example for Windows>

On your computer, click [**Start**], select **Programs** (**All Programs** for Windows XP/Windows Server 2003), then click
MS-DOS Prompt. (for Windows 95/Windows 98)
 Or
Accessories-MS-DOS Prompt. (for Windows Me)
 Or
Command Prompt. (for Windows NT 4.0)
 Or
Accessories-Command Prompt.
 (for Windows 2000/Windows XP/Windows Server 2003)

<Example>

```
C: ¥Documents and Settings>D:
D: ¥>CD ¥PNZZTG****
D: ¥PNZZTG**** >SET_COM=X
D: ¥PNZZTG****>READID
00 52 4F A8 A8
D: ¥PNZZTG****>DOSKEY
D: ¥PNZZTG****>_
```

<Example: error happens>

```
C: ¥Documents and Settings>D:
D: ¥>CD ¥PNZZTG****
D: ¥PNZZTG**** >SET_COM=X
D: ¥PNZZTG****>READID
CreateFile error
ERROR 10: Can't open serial port
D: ¥PNZZTG ****>_
```

Note:

- "****" varies depending on the country or models.

12.2.4. Commands

See the table below for frequently used commands.

| Command name | | Function | Example |
|---|------------------------------|---|--|
| XBT 0 | | Base unit only. For excluding failure of command response. Please send this command at first before other command is executed. *However, if you want to execute "#X" command then DO NOT USE this command. | Type "sendchar XBT 0". |
| rdeeprom | | Read the data of EEPROM | Type "rdeeprom 00 00 FF", and the data from address "00 00" to "FF" is read out. |
| readid | | Read ID (RFPI) | Type "readid", and the registered ID is read out. |
| writeid | | Write ID (RFPI) | Type "writeid 00 18 E0 0E 98", and the ID "0018 E0 0E 98" is written. |
| hookoff | | Off-hook mode on Base | Type "hookoff". |
| hookon | | On-hook mode on Base | Type "hookon". |
| getchk (Base unit) | | Read checksum | Type "getchk". |
| How to use of "getchk" in Handset | 1.rdeeprom | Read EEPROM | Type "RdEeprom 03 7D 04", and the data from address "03 7D" to "03 80" is read out *This command gets 4 byte "WW", "XX", "YY", "ZZ". *Please NEVER forget these 4 byte data! |
| | 2.sendchar epw | Write EEPROM | Type "sendchar epw 03 7D 04 FF FF FF FF" |
| | 3.sendchar RST | Reset baseset | Type "sendchar RST" |
| | 4.getchk | Read checksum | Type "getchk". |
| | 5.sendchar epw | Write EEPROM | Type "sendchar epw 03 7D 04 WW XX YY ZZ" *"WW", "XX", "YY", "ZZ" is 4 byte data that already read from same address. |
| wreeprom | | Write the data of EEPROM | Type "wreeprom 01 23 45". "01 23" is address and "45" is data to be written. |
| hs_burst | | Handset outputs RF power in burst test mode | Type "hs_burst" |
| bs_burst | | Base unit outputs RF power in burst test mode on antenna 2 | Type "bs_burst" |
| tx_high | | Keep TX power high | Type "tx_high" |
| tx_low | | Keep TX power low | Type "tx_low" |
| How to using "#X" command for base unit | | | |
| XBT | | Enter this command before using following command "#X", "bs_burst", "tx_high" "tx_low" for Base Unit. | Type "sendchar XBT 1" and then "OK" is back when it succeeds. (caution) Before entering this command, wait 10 seconds after power on the base unit |
| #X (Attention) When type "sendchar #X" command, must be the "X" must be capital letter. | Read and Write BT parameters | | [Read MAC address] Type "sendchar #X sme" and MAC address is read out (exp. sendchar #XXsme 0080 F08C FFD1) |
| | | | [Write MAC address] Type "sendchar #X sme **** *" and (note) part of **** should be set correct MAC address |
| | | | [Read the data of crystal of BT] Type "sendchar #X nc" and adjustment parameter of crystal of BT is read out (exp. #XXnc=0x1D) |
| | | | [Write the data of crystal of BT] Type "sendchar #X nc *" and adjustment parameter of crystal of BT is read out (note) part of ** should be set the adjusted value. |

Note:

For the command related with BT XBT and #X, the example of this, refer to **Things to Do after Replacing IC or X'tal** (P.64)

12.3. Adjustment Standard (Base Unit)

When connecting the simulator equipment for checking, please refer to below.

12.3.1. Bottom View

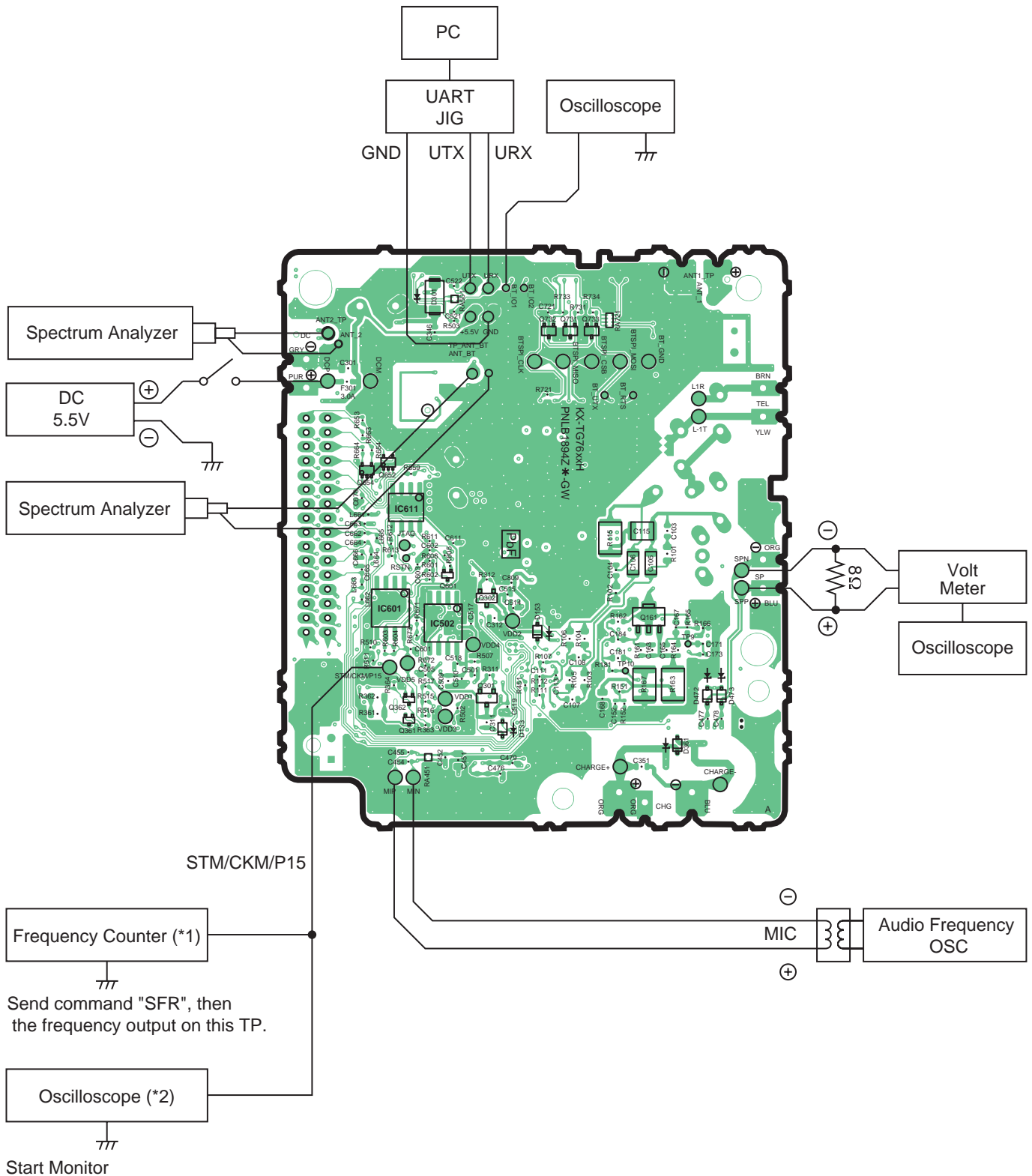

Note:

(*1) is referred to No.2 of Check Check Table for RF part (P.43)

(*2) is referred to Power Supply Circuit/Reset Circuit (P.14)

12.4. Adjustment Standard (Charger Unit)

When connecting the simulator equipment for checking, please refer to below.

12.4.1. Bottom View

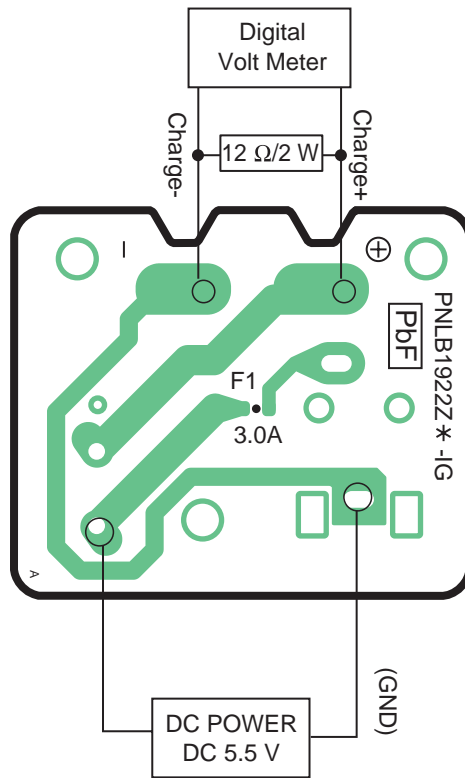

12.5. Adjustment Standard (Handset)

When connecting the simulator equipment for checking, please refer to below.

12.5.1. Component View

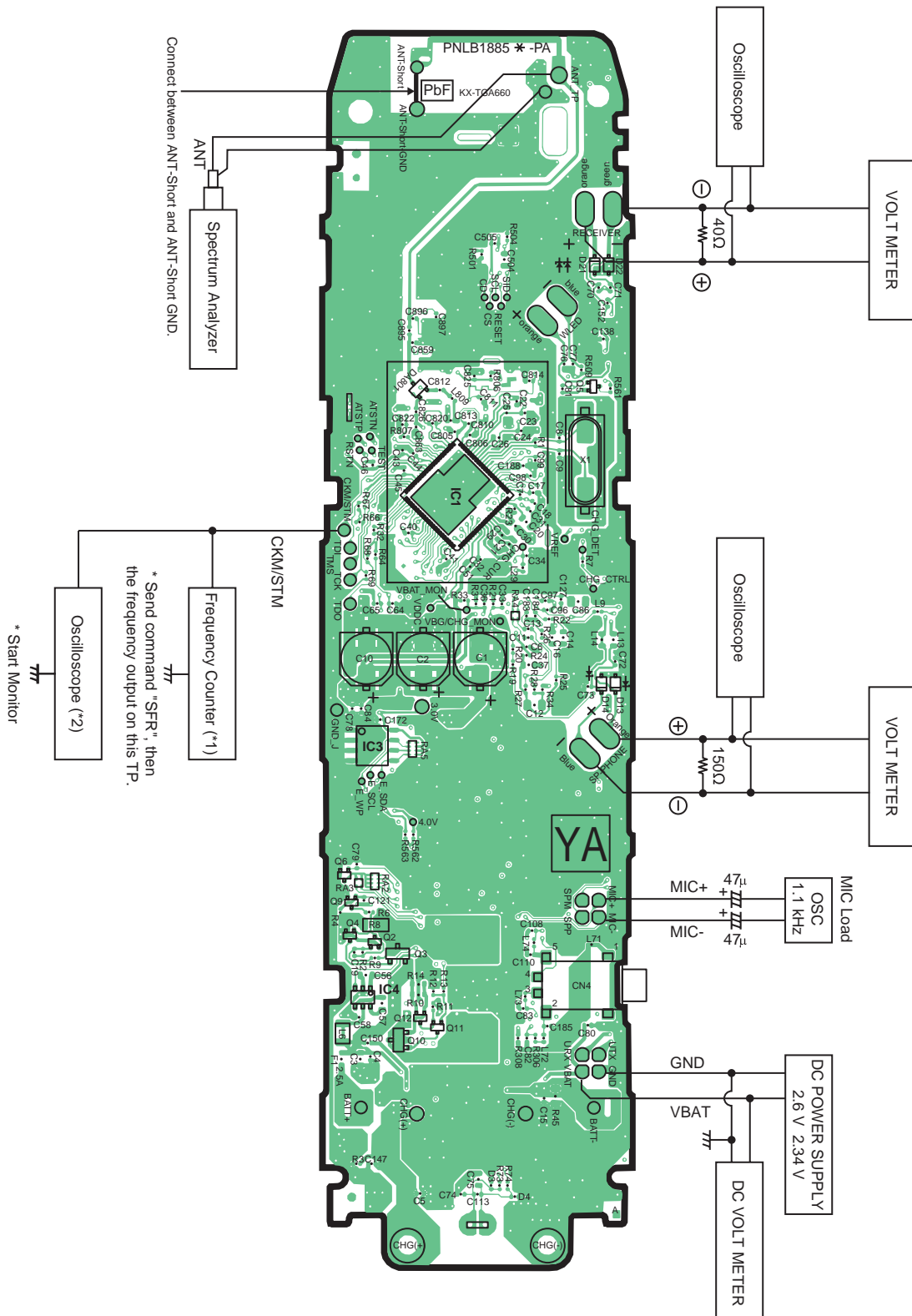

Note:

(*1) is referred to No.2 of Check **Check Table for RF part** (P.43)

(*2) is referred to **Power Supply Circuit/Reset Circuit** (P.22)

12.6. Things to Do after Replacing IC or X'tal

If repairing or replacing EEPROM and X'tal, it is necessary to download the required data such as Programming data or adjustment data, etc. in memory.

The set doesn't operate if it is not executed.

12.6.1. How to download the data

12.6.1.1. Base Unit

First, operate the PC setting according to **The Setting Method of JIG** (P.57).

Then download the appropriate data according to the following procedures.

| Items | | How to download/Required adjustment |
|----------------|---|--|
| BBIC(IC501) | Programming data is stored in memory. | 1) Clock adjustment: Refer to Check Point (H).(*2) |
| EEPROM (IC611) | Adjusted parameter data is stored in memory. (country version batch file, default batch file, etc.) | 1) Change the address "0001" of EEPROM to "AA" to download the data. 2) Default batch file: Execute the command "default.bat". 3) Country version batch file: Execute the command "TG7641US_US_RevXXX_YYY.bat". (*1) 4) Clock adjustment |
| FLASH1 (IC601) | Voice prompt data is stored in memory. (vary depending on country version) | 1) Wait more than 15 seconds after connecting the JIG Cable. 2) Execute the command "VPDL2011 -AA ZZZ.bin" (*1). (writing time: approx. 1 min (115200 bps).) |
| FLASH2 (IC502) | Program D/L | 1) Make sure to connect the JIG cable and disconnect the DC Power in order to download the data. 2) Execute the command "flw441 *****.hex". 3) Connect the DC Power. 4) Press the PC Enter key once. 5) After a few minutes, "Successful upgrade" is displayed on the PC indicating downloading has finished. 6) Detach the JIG cable, then disconnect the DC Power. 7) Connect the DC Power. 8) Connect the JIG cable again, and execute the command "getchk", then confirm the checksum value is correct. (If the downloading fails, start again from step 1). 9) Default batch file: Execute the command "default.bat". 10) Country version batch file: Execute the command "TG7641US_US_RevXXX_YYY.bat". (*1) 11) Clock adjustment: Refer to Check Point (H). (*2) |
| X'tal (X1) | System clock | Clock adjustment data is in EEPROM, adjust the data again after replacing it. 1) Apply 5.5V between DCP and DCM with DC power. 2) Input Command "sendchar sfr", then you can confirm the current value. 3) Check X'tal Frequency.(10.368MHz \pm 41Hz). 4) If the frequency is not 10.368MHz \pm 41Hz, adjust the frequency of CLK executing the command "sendchar sfr xx xx (where xx is the value)" so that the reading of the frequency counter is 10.368MHz \pm 5Hz. |

Note:

(*1) XXX_YYY: revision number, ZZZ:Voice prompt, AA: Baud rate(9600/19200/57600/115200)

"XXX_YYY and "ZZZ" vary depending on the country version. You can find them in the batch file, PNZZ- mentioned in **The Setting Method of JIG** (P.57).

When adjust the frequency the BT Unit or write the MAC address to the BT Unit.

| | Item | Test command | | Description |
|---|-------------------------|---|------------------------------------|--|
| | | Input | Echo back | |
| 1 | Power on | - | - | Wait 10seconds and connect JIG |
| 2 | Test mode | sendchar XBT 1 ↵ sendchar #X ts ↵ | OK #XXTEST | Enter"XBT 1" and then "OK" is back when it succeeds to enter test mode. |
| 3 | Confirm a default value | sendchar #X nc ↵ | #XXnc=0x1A | Confirm a default value before adjusting the frequency. |
| 4 | Adjust the frequency | sendchar #X b3 39 19 ↵ sendchar nc,, ↵ | #XXTS ch=2441 pwr=19 #XXnc=0x,, | Adjust the frequency to "2441MHz \pm 10kHz" by changing the value of,, Test Point: ANT-C3, refer to Bottom View (P.86) |

Note:

↵: Enter key

12.6.1.2. Handset

First, operate the PC setting according to **The Setting Method of JIG** (P.57).

Then download the appropriate data according to the following procedures.

| Items | | How to download/Required adjustment |
|--------------|---|---|
| EEPROM (IC3) | Adjusted parameter data is stored in memory. (country version batch file, default batch file, etc.) | <ol style="list-style-type: none"> 1) Default batch file: Execute the command "default.bat". 2) Default batch file (remaining): Execute the command "TGA660US_DEF_RevXXX_YYY.bat". (*2) 3) Country version batch file: Execute the command "TGA660US_US_RevXXX_YYY.bat". (*2) 4) Clock adjustment 5) 2.35 V setting and battery low detection |
| X'tal (X1) | System clock | <ol style="list-style-type: none"> 1) Apply 2.6V between BATT+ and BATT- with DC power. 2) Input Command " sendchar sfr", then you can confirm the current value. 3) Check X'tal Frequency.(13.824 MHz \pm 100 Hz). 4) If the frequency is not 13.824 MHz \pm 100 Hz, adjust the frequency of CLK executing the command "sendchar sfr xx xx (where xx is the value)" so that the reading of the frequency counter is 13.824000 MHz \pm 5 Hz. |

Note:

(*2) XXX_YYY: revision number

"XXX_YYY" vary depending on the country version. You can find them in the batch file, PNZZ- mentioned in **The Setting Method of JIG** (P.57).

12.7. Frequency Table

| | Ch. (hex) | TX/RX Frequency (MHz) |
|-----------|-----------|-----------------------|
| Channel 0 | 00 | 1928.448 |
| Channel 1 | 01 | 1926.720 |
| Channel 2 | 02 | 1924.992 |
| Channel 3 | 03 | 1923.264 |
| Channel 4 | 04 | 1921.536 |

12.8. Bluetooth Frequency Table

| Ch. | Frequency (MHz) | Ch. | Frequency (MHz) | Ch. | Frequency (MHz) |
|-----|-----------------|-----|-----------------|-----|-----------------|
| 0 | 2402 | 33 | 2435 | 66 | 2468 |
| 1 | 2403 | 34 | 2436 | 67 | 2469 |
| 2 | 2404 | 35 | 2437 | 68 | 2470 |
| 3 | 2405 | 36 | 2438 | 69 | 2471 |
| 4 | 2406 | 37 | 2439 | 70 | 2472 |
| 5 | 2407 | 38 | 2440 | 71 | 2473 |
| 6 | 2408 | 39 | 2441 | 72 | 2474 |
| 7 | 2409 | 40 | 2442 | 73 | 2475 |
| 8 | 2410 | 41 | 2443 | 74 | 2476 |
| 9 | 2411 | 42 | 2444 | 75 | 2477 |
| 10 | 2412 | 43 | 2445 | 76 | 2478 |
| 11 | 2413 | 44 | 2446 | 77 | 2479 |
| 12 | 2414 | 45 | 2447 | 78 | 2480 |
| 13 | 2415 | 46 | 2448 | | |
| 14 | 2416 | 47 | 2449 | | |
| 15 | 2417 | 48 | 2450 | | |
| 16 | 2418 | 49 | 2451 | | |
| 17 | 2419 | 50 | 2452 | | |
| 18 | 2420 | 51 | 2453 | | |
| 19 | 2421 | 52 | 2454 | | |
| 20 | 2422 | 53 | 2455 | | |
| 21 | 2423 | 54 | 2456 | | |
| 22 | 2424 | 55 | 2457 | | |
| 23 | 2425 | 56 | 2458 | | |
| 24 | 2426 | 57 | 2459 | | |
| 25 | 2427 | 58 | 2460 | | |
| 26 | 2428 | 59 | 2461 | | |
| 27 | 2429 | 60 | 2462 | | |
| 28 | 2430 | 61 | 2463 | | |
| 29 | 2431 | 62 | 2464 | | |
| 30 | 2432 | 63 | 2465 | | |
| 31 | 2433 | 64 | 2466 | | |
| 32 | 2434 | 65 | 2467 | | |

13 Miscellaneous

13.1. How to Replace the LLP (Leadless Leadframe Package) IC

Note:

This description is only applied on the model with Shield case.

13.1.1. Preparation

- PbF (: Pb free) Solder
- Soldering Iron
Tip Temperature of 700 °F ± 20 °F (370 °C ± 10 °C)

Note:

We recommend a 30 to 40 Watt soldering iron. An expert may be able to use a 60 to 80 Watt iron where someone with less experience could overheat and damage the PCB foil.

- Hot Air Desoldering Tool
Temperature: 608 °F ± 68 °F (320 °C ± 20 °C)

13.1.2. Caution

- To replace the IC efficiently, choose the right sized nozzle of the hot air desoldering tool that matches the IC package.
- Be careful about the temperature of the hot air desoldering tool not to damage the PCB and/or IC.

13.1.3. How to Remove the IC

1. Heat the IC with a hot air desoldering tool through the P.C.Board.

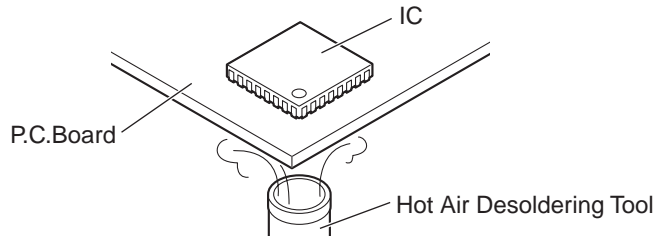

2. Pick up the IC with tweezers, etc. when the solder is melted completely.

Note:

- Be careful not to touch the peripheral parts with tweezers, etc. They are unstable.

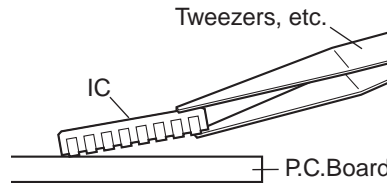

When it is hard to melt the solder completely, heat it with a hot air desoldering tool through the IC besides through the P.C.Board.

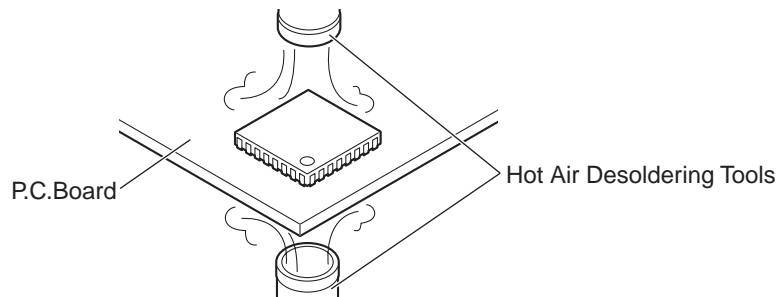

3. After removing the IC, clean the P.C.Board of residual solder.

13.1.4. How to Install the IC

1. Place the solder a little on the land where the radiation GND pad on IC bottom is to be attached.

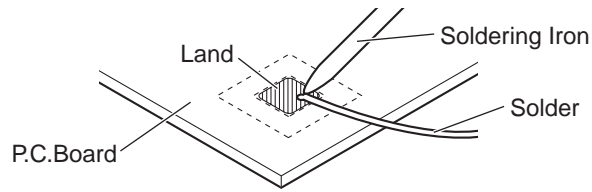

2. Place the solder a little on the land where IC pins are to be attached, then place the IC.

Note:

- When placing the IC, the positioning should be done very carefully.

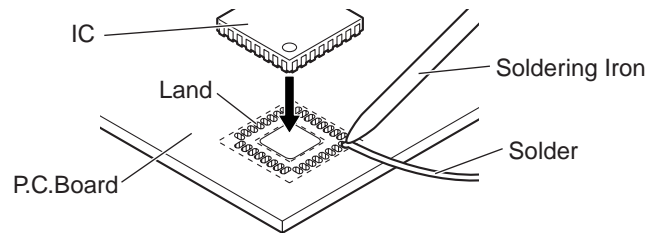

3. Heat the IC with a hot air desoldering tool through the P.C.Board until the solder on IC bottom is melted.

Note:

- Be sure to place it precisely, controlling the air volume of the hot air desoldering tool.

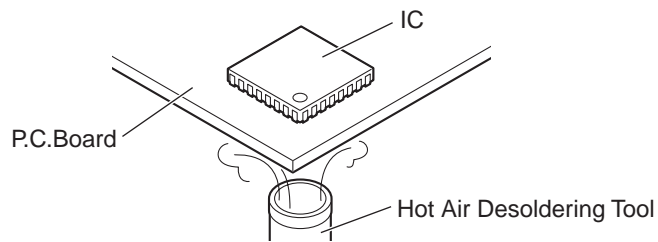

4. After soldering, confirm there are no short and open circuits with visual inspection.

13.2. How to Replace the Flat Package IC

Even if you do not have the special tools (for example, a spot heater) to remove the Flat IC, with some solder (large amount), a soldering iron and a cutter knife, you can easily remove the ICs that have more than 100 pins.

13.2.1. Preparation

- PbF (: Pb free) Solder

- Soldering Iron

Tip Temperature of 700 °F ± 20 °F (370 °C ± 10 °C)

Note: We recommend a 30 to 40 Watt soldering iron. An expert may be able to use a 60 to 80 Watt iron where someone with less experience could overheat and damage the PCB foil.

- Flux

Recommended Flux: Specific Gravity → 0.82.

Type → RMA (lower residue, non-cleaning type)

Note: See **About Lead Free Solder (PbF: Pb free)** (P.4)

13.2.2. How to Remove the IC

1. Put plenty of solder on the IC pins so that the pins can be completely covered.

Note:

If the IC pins are not soldered enough, you may give pressure to the P.C. board when cutting the pins with a cutter.

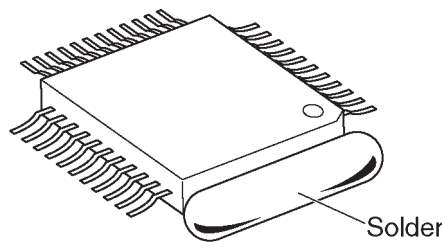

2. Make a few cuts into the joint (between the IC and its pins) first and then cut off the pins thoroughly.

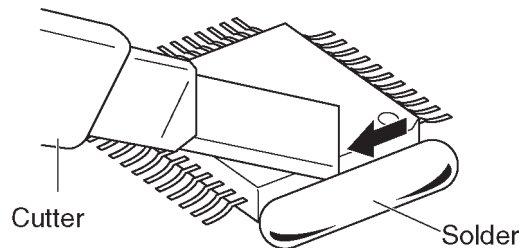

3. While the solder melts, remove it together with the IC pins.

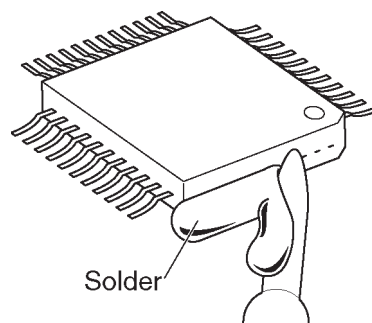

When you attach a new IC to the board, remove all solder left on the board with some tools like a soldering wire. If some solder is left at the joint on the board, the new IC will not be attached properly.

13.2.3. How to Install the IC

1. Temporarily fix the FLAT PACKAGE IC, soldering the two marked pins.

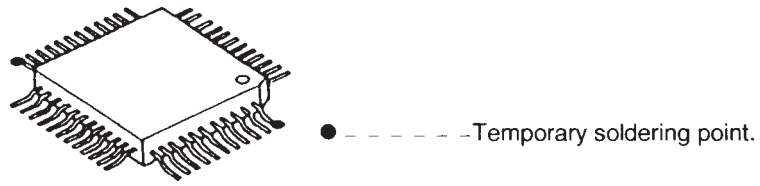

*Check the accuracy of the IC setting with the corresponding soldering foil.

2. Apply flux to all pins of the FLAT PACKAGE IC.

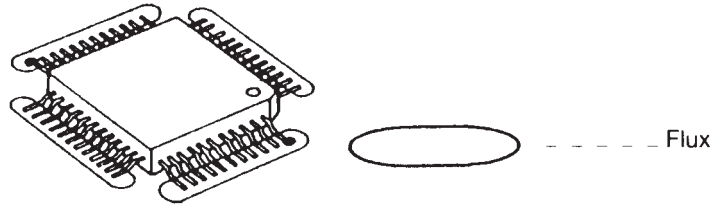

3. Solder the pins, sliding the soldering iron in the direction of the arrow.

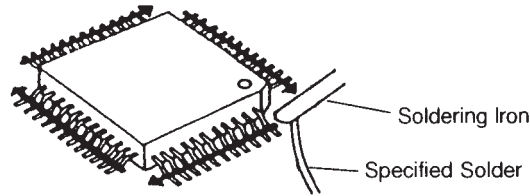

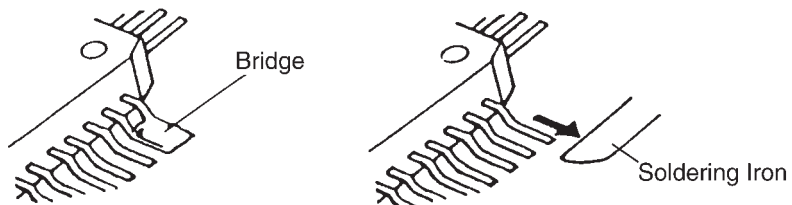

13.2.4. How to Remove a Solder Bridge

1. Lightly resolder the bridged portion.
2. Remove the remaining solder along the pins using a soldering iron as shown in the figure below.



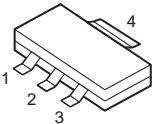
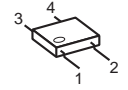
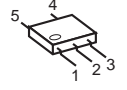
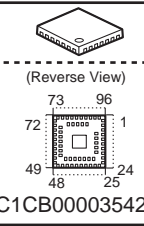
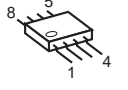
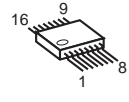
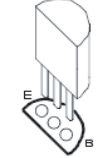
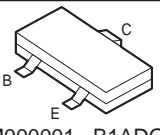
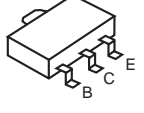
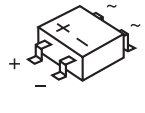
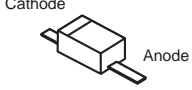

13.3. Terminal Guide of the ICs, Transistors and Diodes

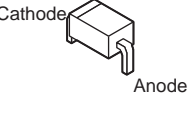
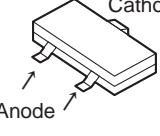
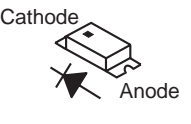
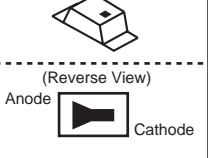
13.3.1. Base Unit

| | | | | |
|---|---|--|---|---|
|  <p>C0CBAYG00016</p> |  <p>C0EBE0000124</p> |  <p>C0CBCCC00103 B1GFCFEN0011</p> |  <p>(Reverse View) C1CB00003542</p> |  <p>PNWI1TG7641H PNWI2TG7621H PNWI3TG7621H</p> |
|  <p>C0JBAQ000247</p> |  <p>B1ACGP000008</p> |  <p>B1ABDM000001, B1ADGE000012 B1ADNB000003, B1ABDF000017 B1GBCFYY0010, B1GBCFYY0020 2SA1576S, PQVTDTC114TU</p> |  <p>DSC7003S0L</p> | |
|  <p>PQVDMD5S</p> |  <p>1SS355</p> |  <p>PQVDPTZT2530</p> |  <p>B0ECKM000008</p> |  <p>B0DDCD000001</p> |
|  <p>LNJ237W82RA</p> |  <p>(Reverse View) B3ABB0000331</p> | | | |

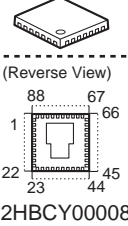
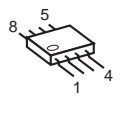
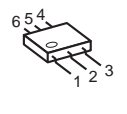
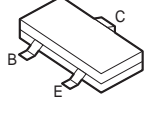
13.3.2. Handset

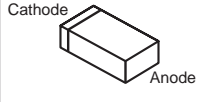
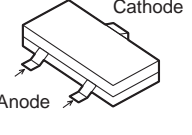
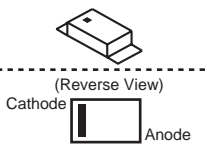
| | | | | |
|--|---|--|---|---|
|  <p>(Reverse View) C2HBCY000081</p> |  <p>PNWITGA660BR</p> |  <p>C0DBZYY00357</p> |  <p>B1ADCF000040 B1GBCFYY0010 B1ABDF000017 B1ADNB000003</p> |  <p>B1ABGE000011</p> |
|  <p>B0BC4R3A0006</p> |  <p>B0DDCD000001</p> |  <p>(Reverse View) B3ACB0000216</p> | | |

14 Schematic Diagram

14.1. For Schematic Diagram

14.1.1. Base Unit (Schematic Diagram (Base Unit_Main))

Notes:

1. DC voltage measurements are taken with voltmeter from the negative voltage line.

Important Safety Notice:

Components identified by \triangle mark have special characteristics important for safety. When replacing any of these components, use only the manufacture's specified parts.

2. The schematic diagrams may be modified at any time with the development of new technology.

14.1.2. Handset (Schematic Diagram (Handset_Main))

Notes:

1. DC voltage measurements are taken with an oscilloscope or a tester with a ground.
2. The schematic diagrams may be modified at any time with the development of new technology.

14.1.3. Charger Unit (Schematic Diagram (Charger Unit))

Notes:

1. DC voltage measurements are taken with voltmeter from the negative voltage line.

Important Safety Notice:

Components identified by \triangle mark have special characteristics important for safety. When replacing any of these components, use only the manufacture's specified parts.

2. The schematic diagrams may be modified at any time with the development of new technology.

14.2. Schematic Diagram (Base Unit_Main)

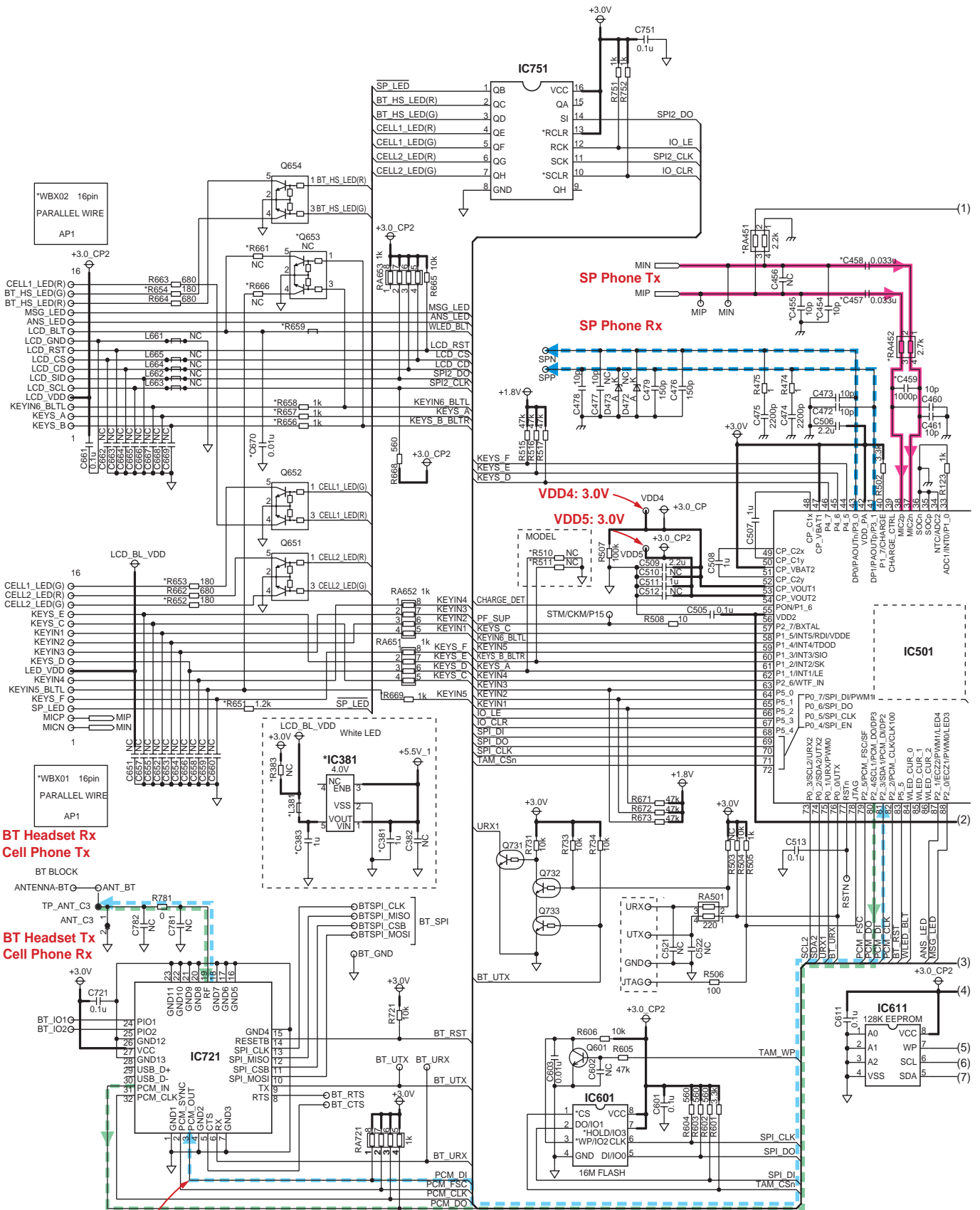

NC: No Components

REFERENCE
 1XX: TEL LINE
 3XX: POWER, CHARGE
 4XX: MIC, SP
 5XX: BBIC
 6XX: FLASH, EEPROM, KEY, LCD
 7XX: FOR DK/BT
 8XX: RF

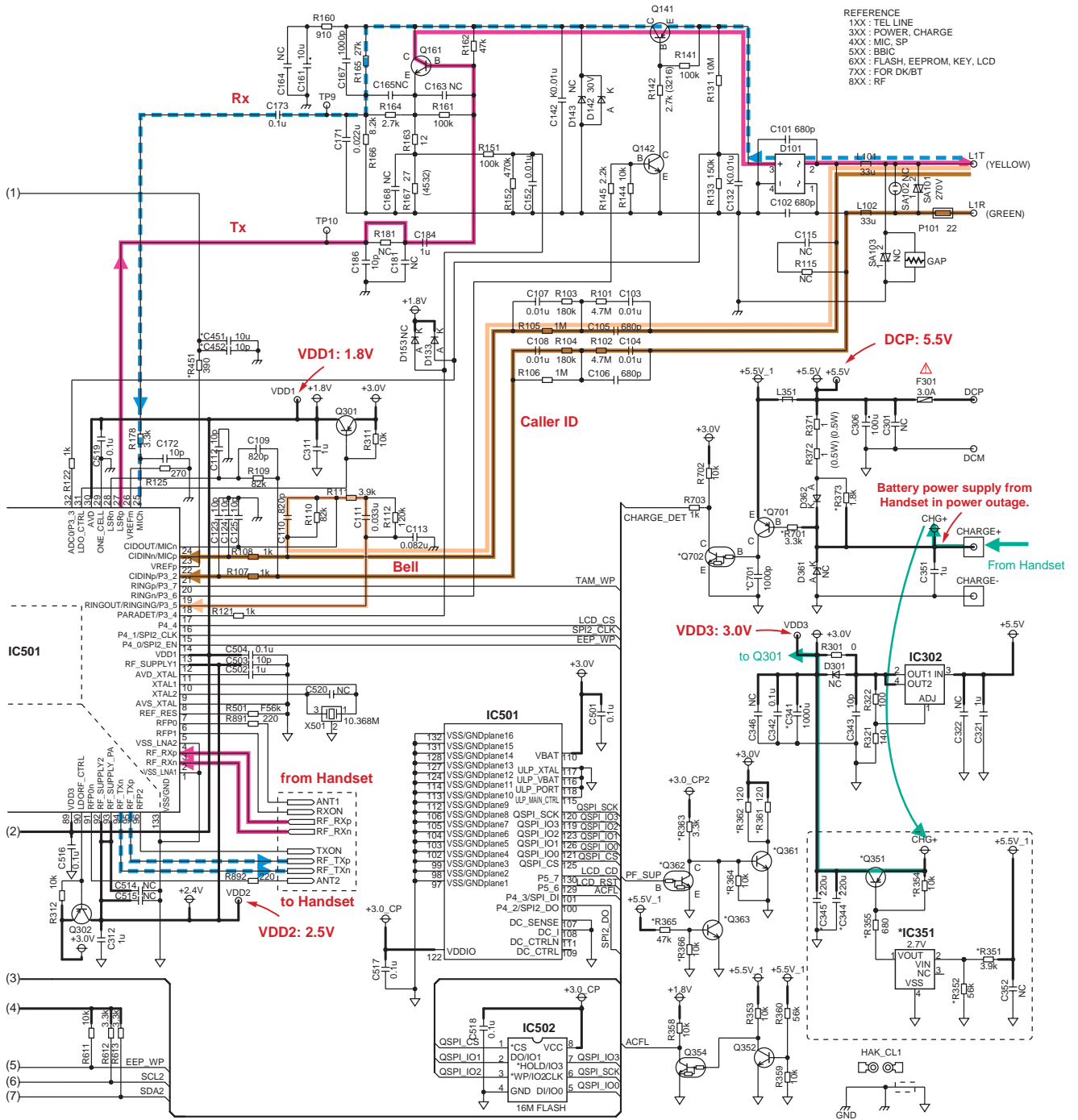

NC: No Components

KX-TG155 SCHEMATIC DIAGRAM (Base Unit_Main)

14.3. Schematic Diagram (Base Unit_RF)

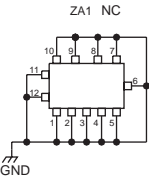
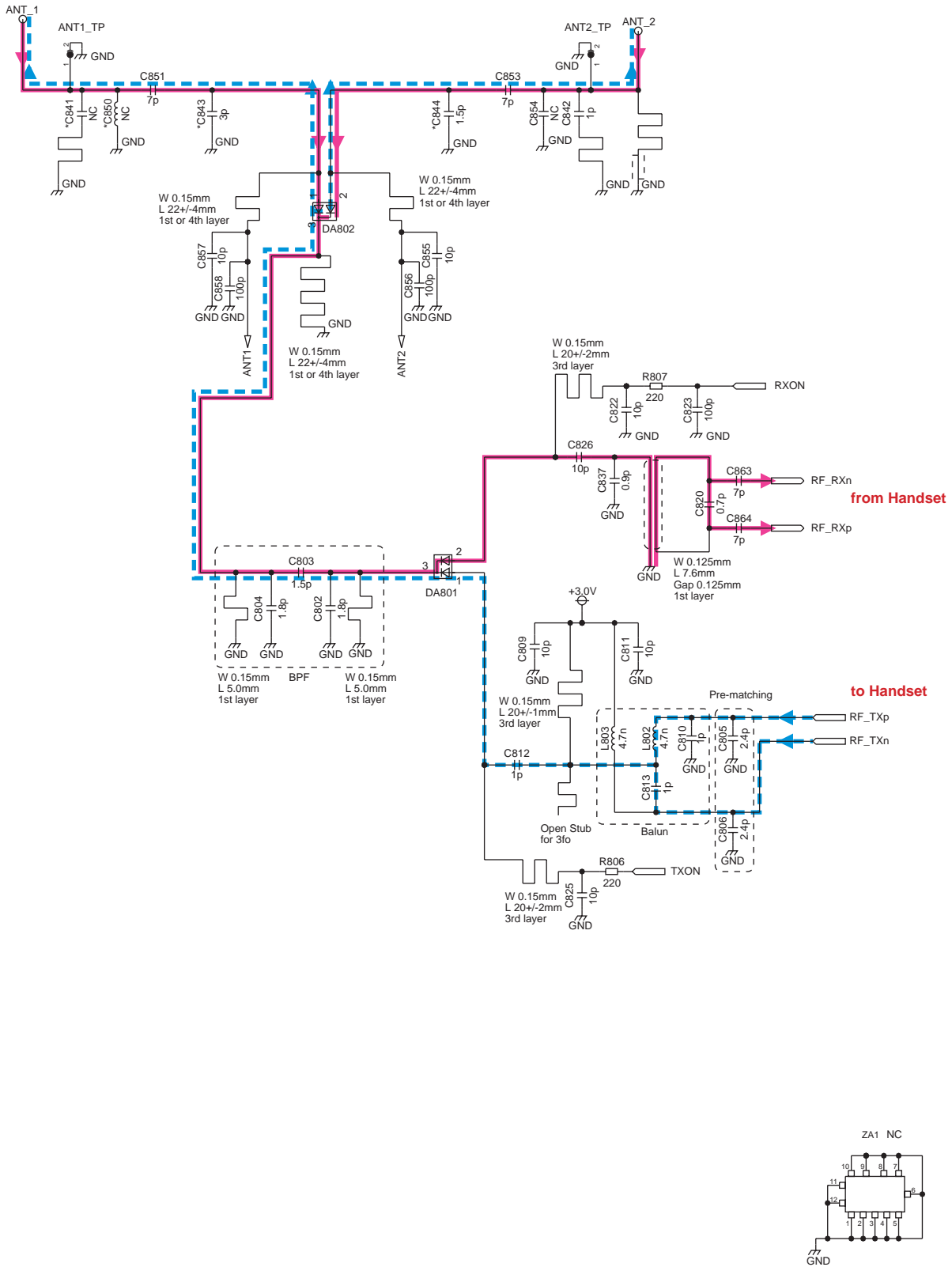

NC: No Components

KX-TG155 SCHEMATIC DIAGRAM (Base Unit_RF)

14.4. Schematic Diagram (Base Unit_Operation)

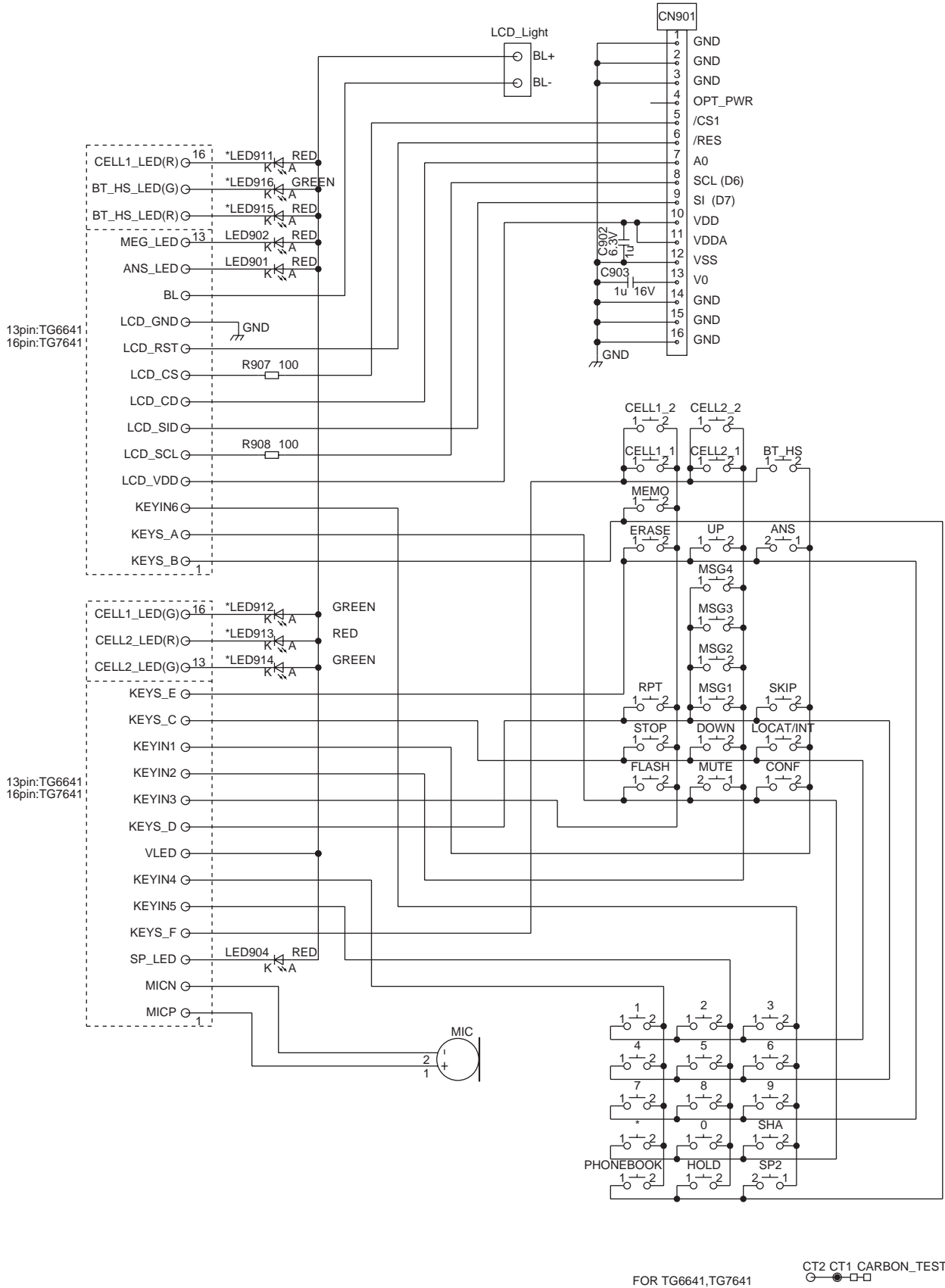

NC: No Components

KX-TG155 SCHEMATIC DIAGRAM (Base Unit_Operation)

14.5. Schematic Diagram (Base Unit_LED)

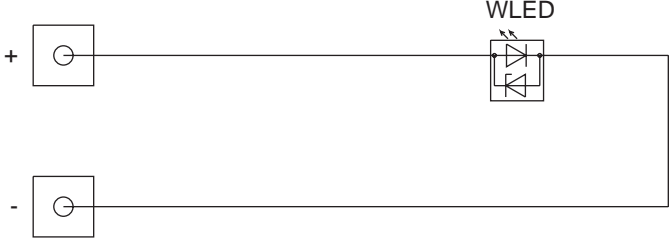

NC: No Components

KX-TG155 SCHEMATIC DIAGRAM (Base Unit_LED)

Memo

14.7. Schematic Diagram (Handset_LED)

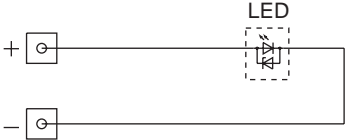

KX-TGA660 SCHEMATIC DIAGRAM (Handset_LED)

14.8. Schematic Diagram (Charger Unit)

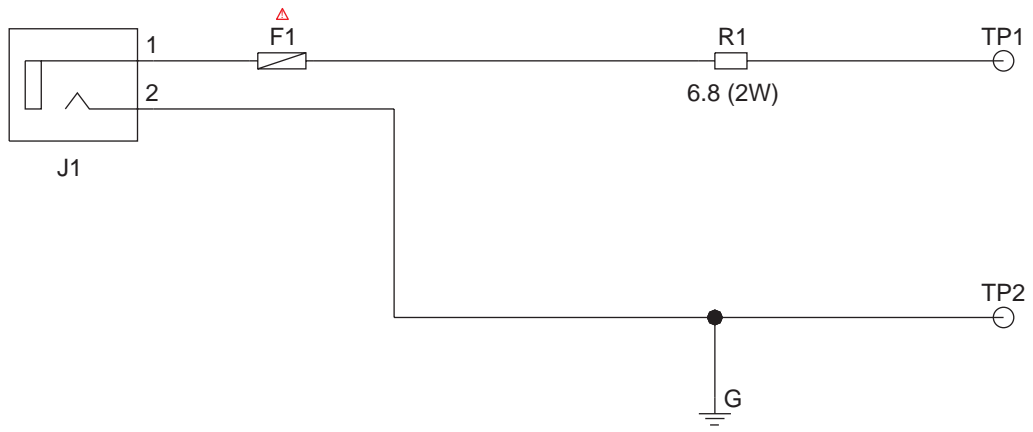

SCHEMATIC DIAGRAM (Charger Unit)

Memo

15.1.2. Bottom View

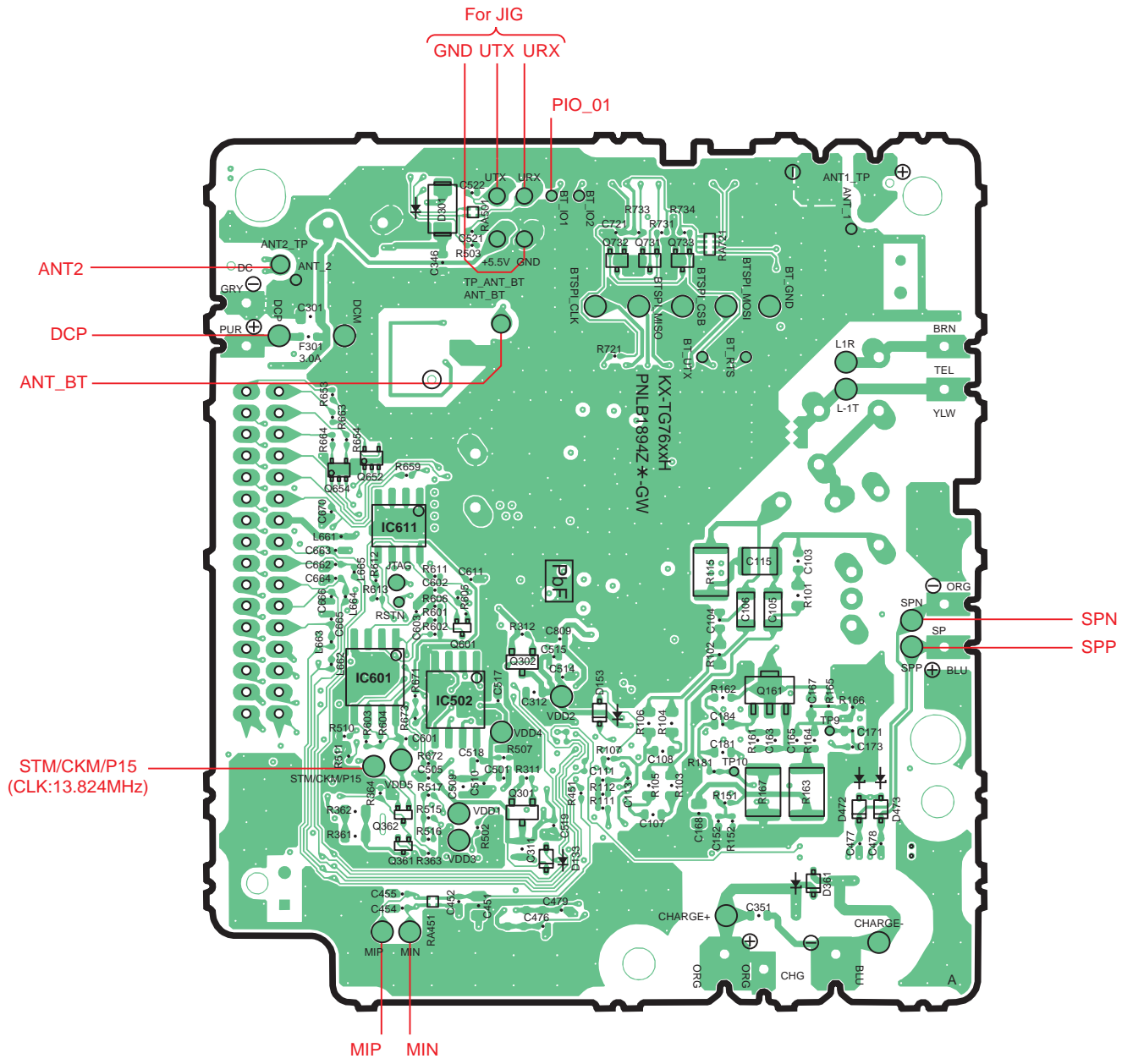

KX-TG155 CIRCUIT BOARD (Base Unit_Main (Bottom View))

15.2. Circuit Board (Base Unit_Operation)

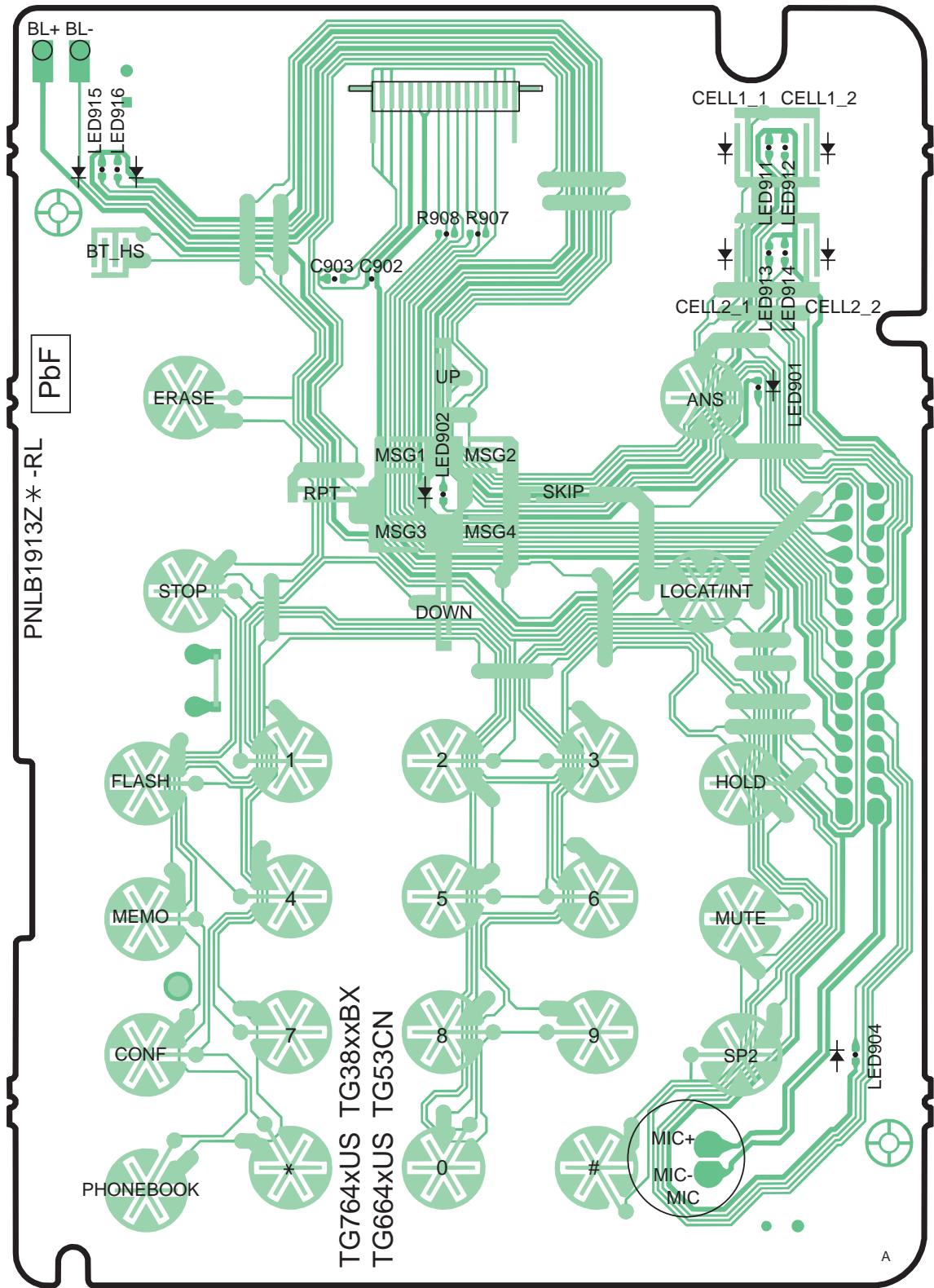

KX-TG155 CIRCUIT BOARD (Base Unit_Operation (Component View))

15.3. Circuit Board (Base Unit_LED)

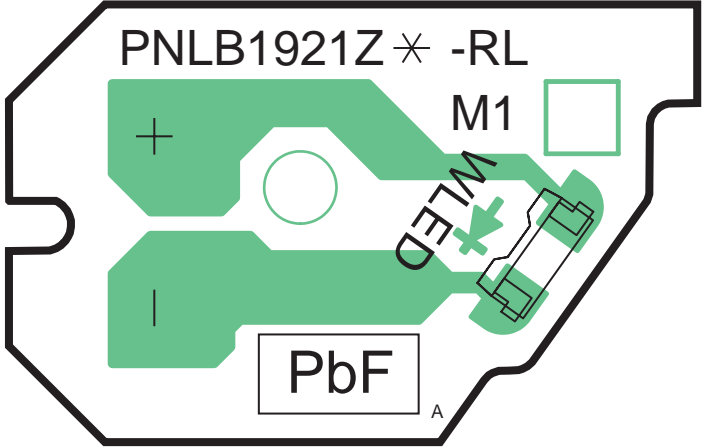

KX-TG155 CIRCUIT BOARD (Base Unit_LED (Component View))

15.4. Circuit Board (Handset_Main)

15.4.1. Component View

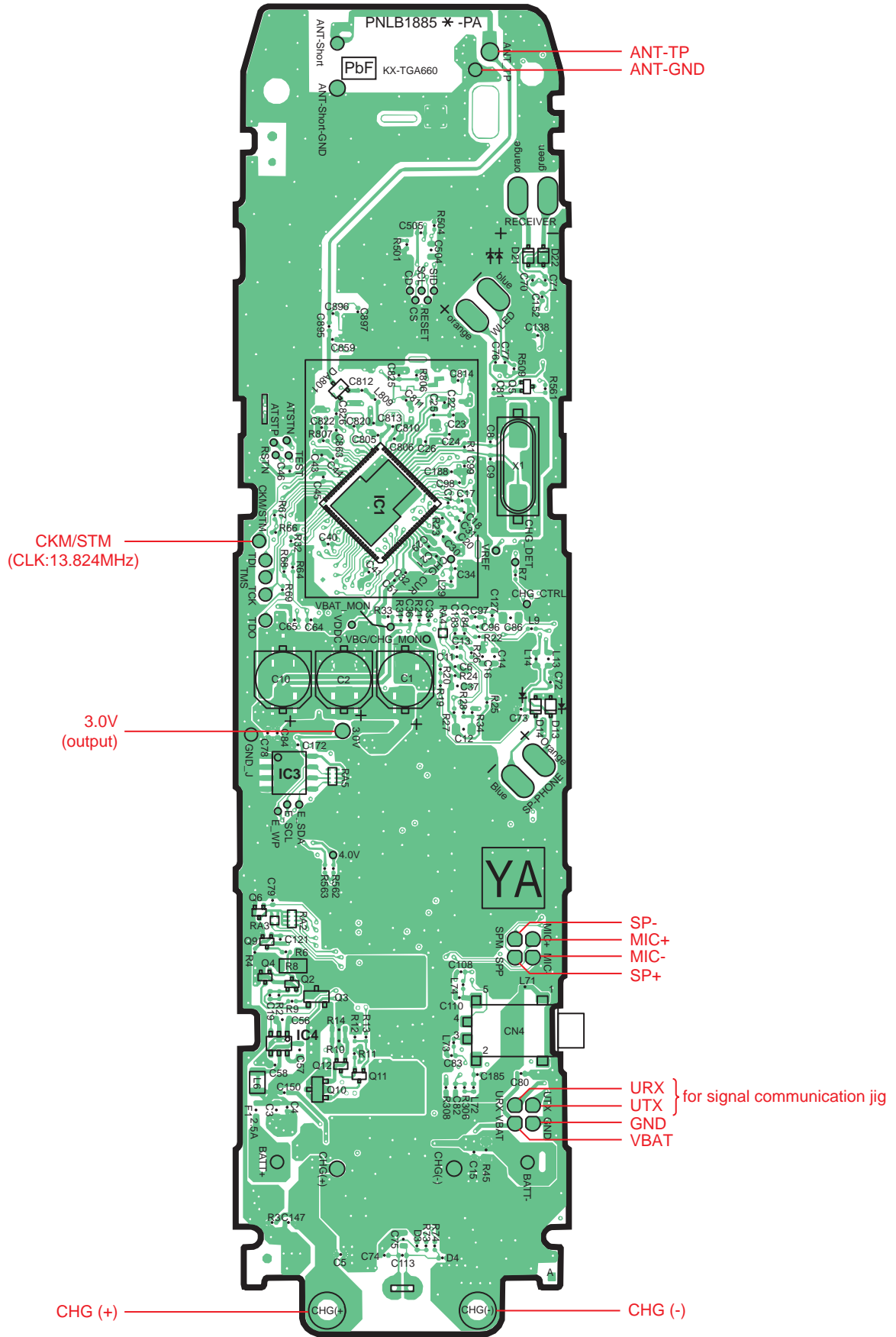

KX-TGA660 CIRCUIT BOARD (Handset_Main (Component View))

15.4.2. Bottom View

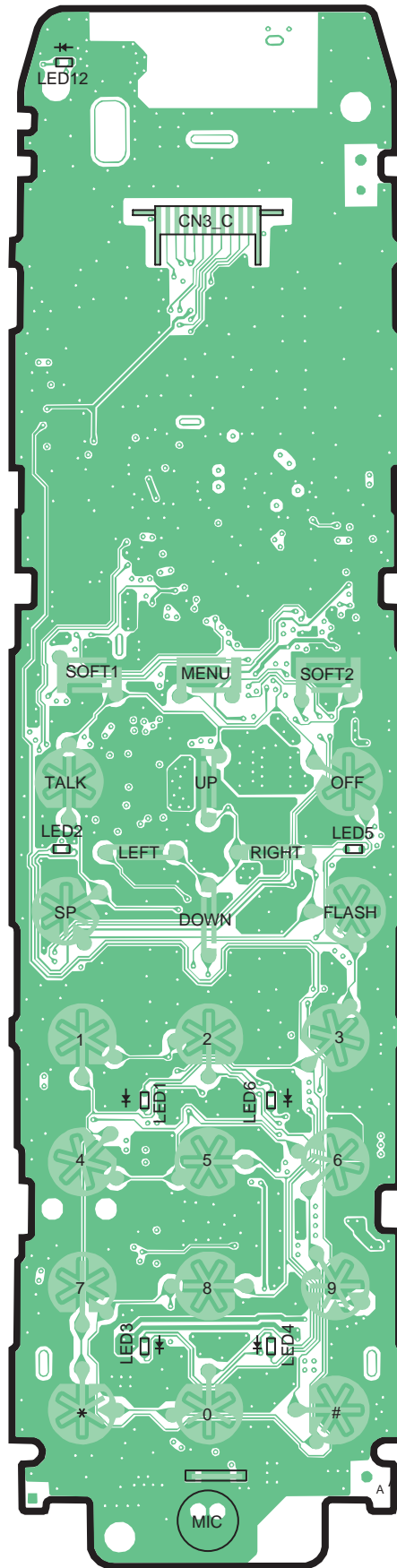

KX-TGA660 CIRCUIT BOARD (Handset_Main (Bottom View))

15.5. Circuit Board (Handset_LED)

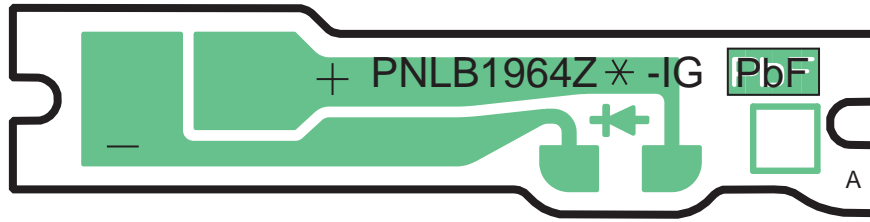

KX-TGA660 CIRCUIT BOARD (Handset_LED (Component View))

15.6. Circuit Board (Charger Unit)

15.6.1. Component View

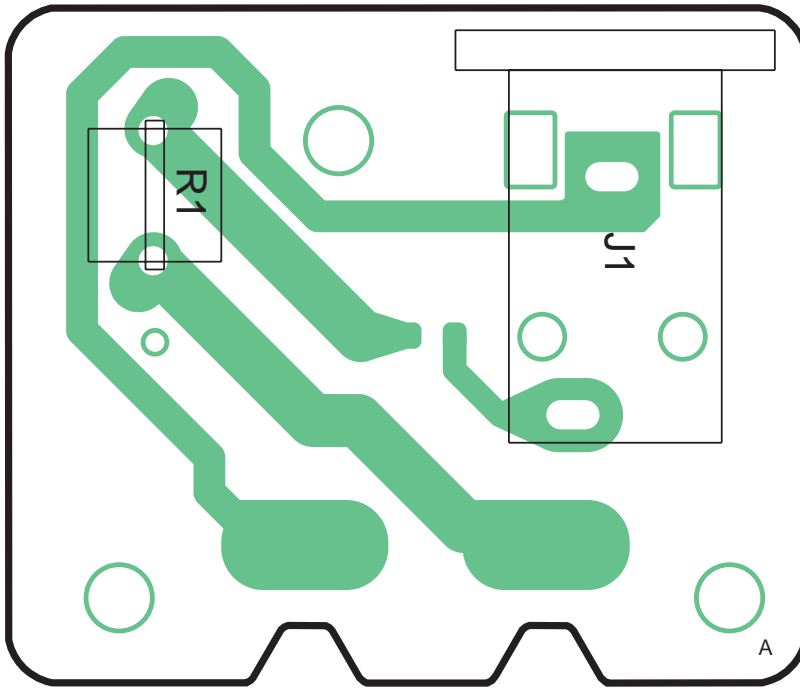

CIRCUIT BOARD (Charger Unit (Component View))

15.6.2. Bottom View

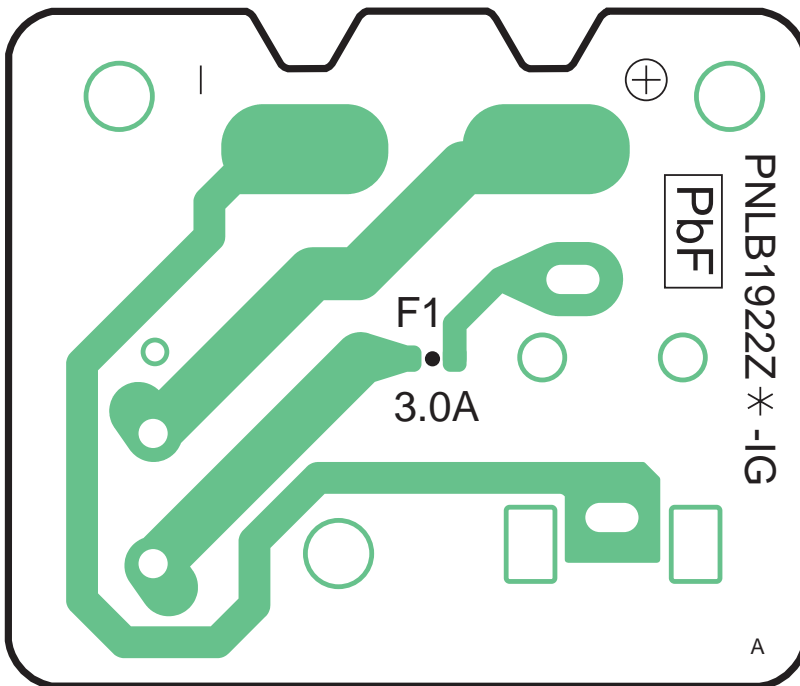

CIRCUIT BOARD (Charger Unit (Bottom View))

16 Exploded View and Replacement Parts List

16.1. Cabinet and Electrical Parts (Base Unit)

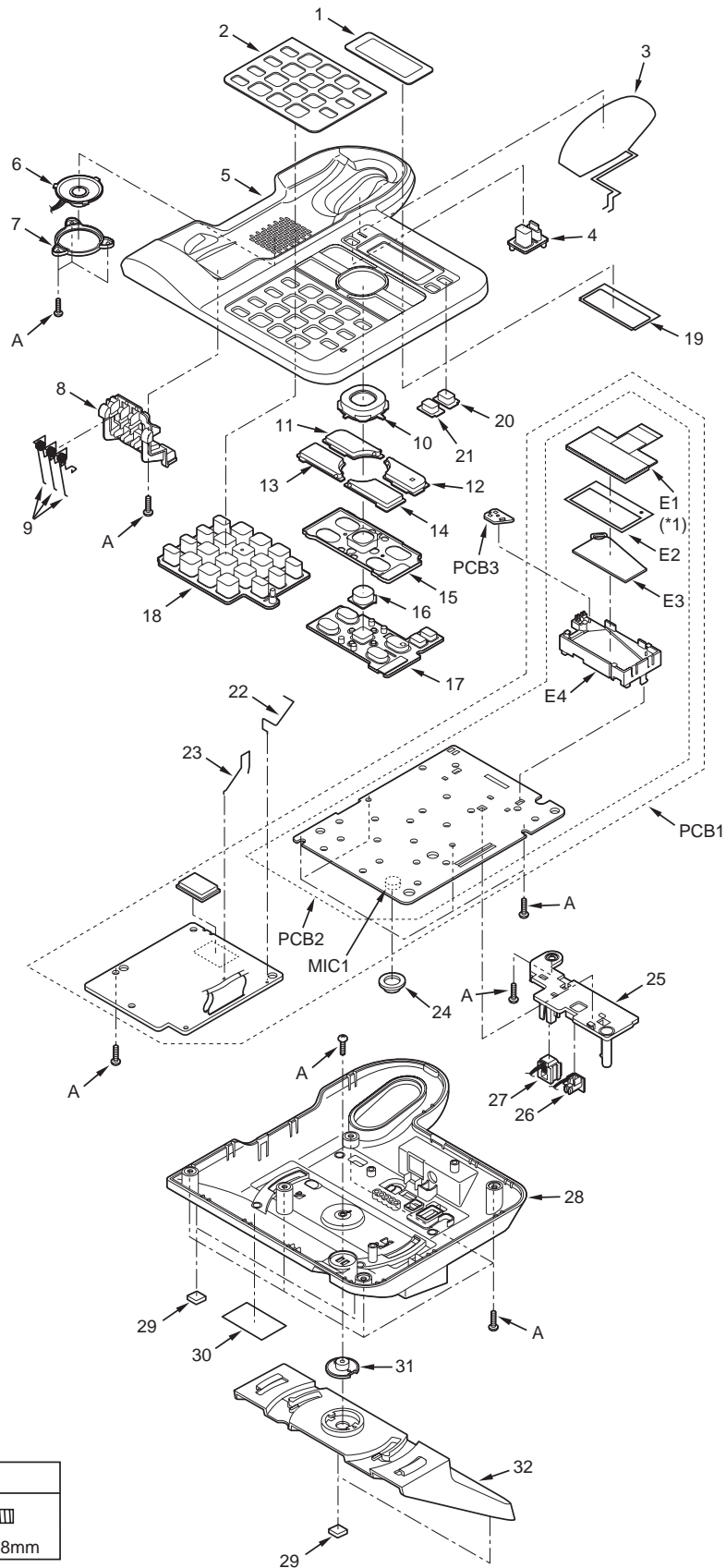

| Ref.No. | Figure |
|---------|--|
| A |  φ 2.6 x 8mm |

Note:

(*1) This cable is fixed by welding. Refer to **How to Replace the Base unit LCD (P.54)**.

16.2. Cabinet and Electrical Parts (Handset)

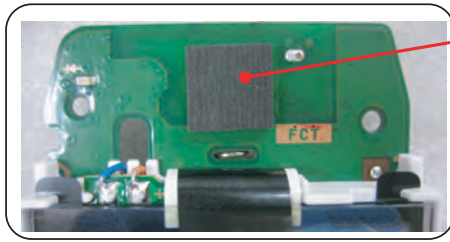

CUSHION RUBBER
*STICK IT WITHIN THE FRAMEWORK ON P.C.B.

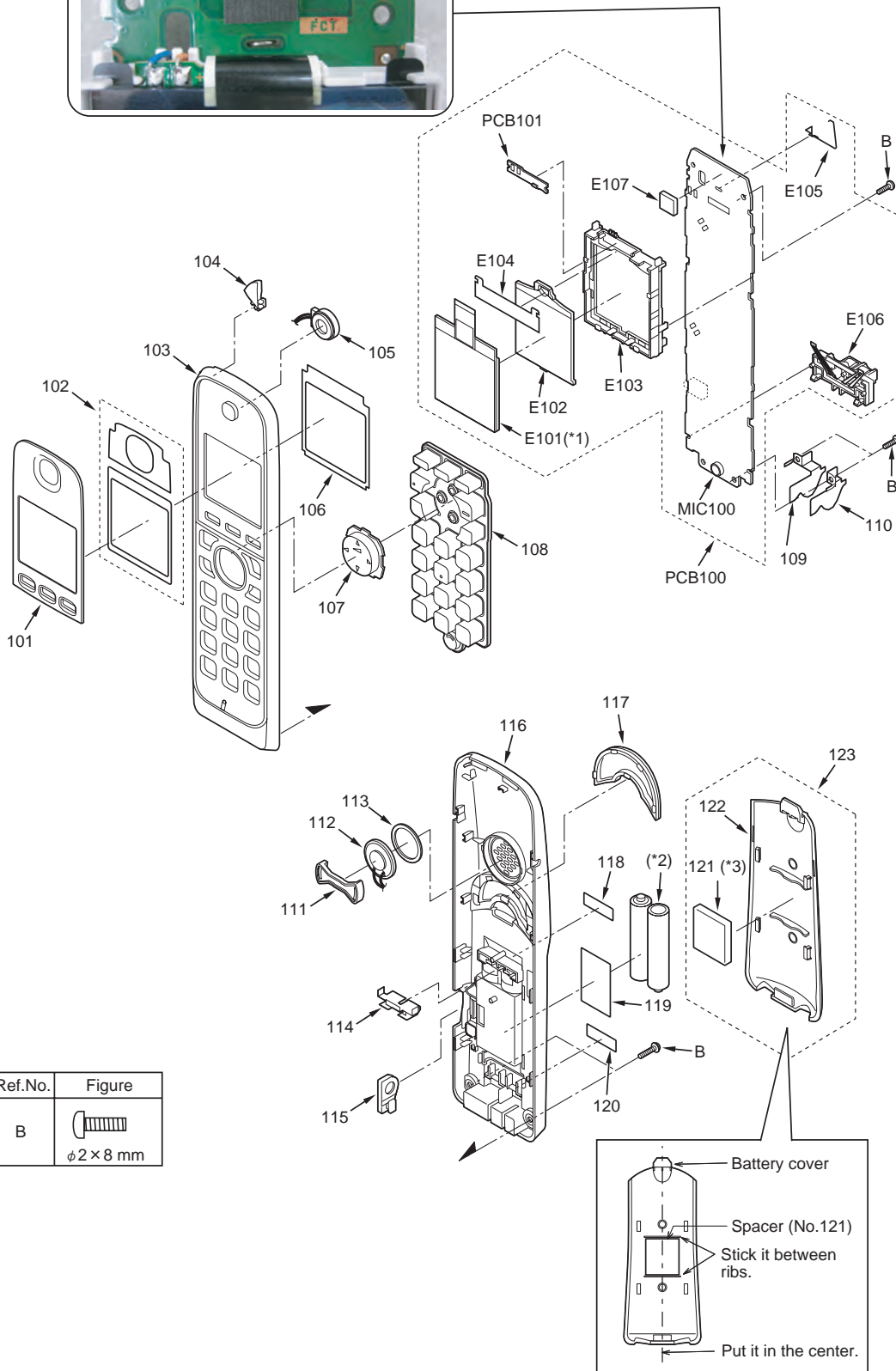



| Ref.No. | Figure |
|---------|--|
| B |  φ2×8 mm |

Note:

- (*1) This cable is fixed by welding. Refer to **How to Replace the Handset LCD (P.56)**.
- (*2) The rechargeable Ni-MH battery HHR-4DPA is available through sales route of Panasonic.
- (*3) Attach the SPACER (No. 121) to the exact location described above.

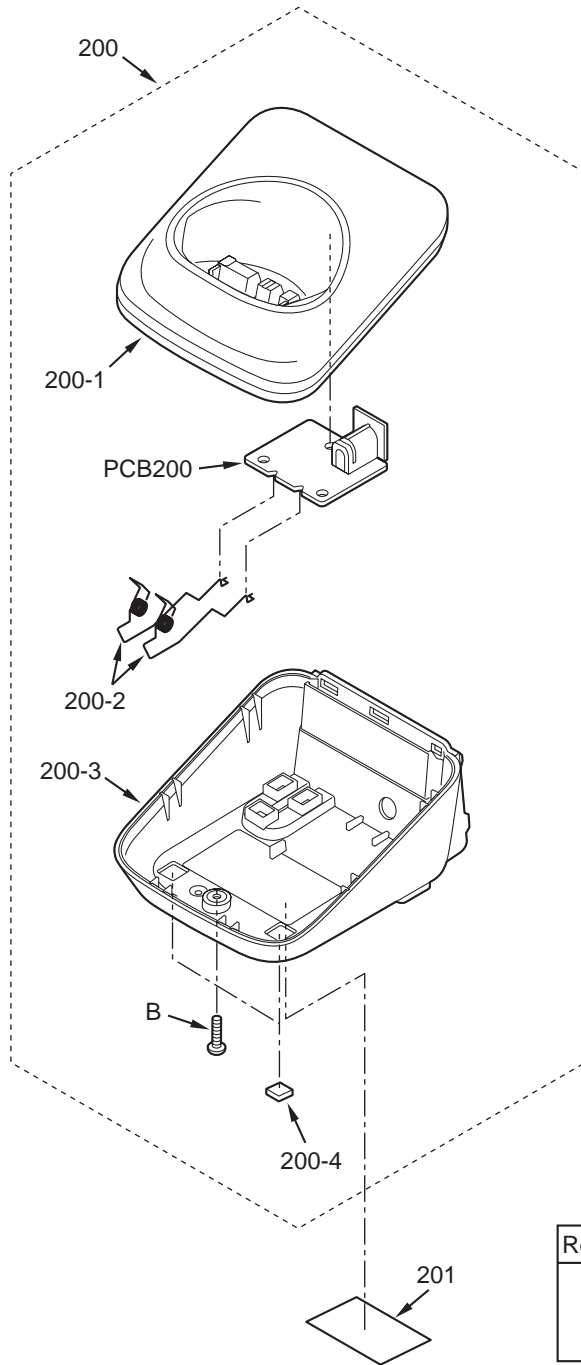
16.3. Cabinet and Electrical Parts (Charger Unit)



| Ref.No. | Figure |
|---------|---|
| B |  2 x 8 mm |

16.4. Accessories

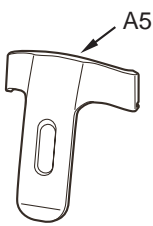
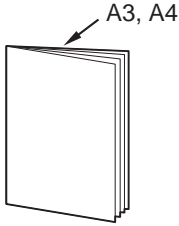
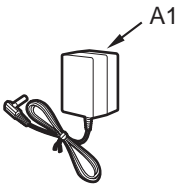

16.5. Replacement Parts List

1. RTL (Retention Time Limited)

Note:

The "RTL" marking indicates that its Retention Time is Limited.

When production is discontinued, this item will continue to be available only for a specific period of time.

This period of time depends on the type of item, and the local laws governing parts and product retention. At the end of this period, the item will no longer be available.

2. Important safety notice

Components identified by the Δ mark indicates special characteristics important for safety. When replacing any of these components, only use specified manufacturer's parts.

3. The S mark means the part is one of some identical parts.

For that reason, it may be different from the installed part.

4. ISO code (Example: ABS-94HB) of the remarks column shows quality of the material and a flame resisting grade about plastics.

5. RESISTORS & CAPACITORS

Unless otherwise specified;

All resistors are in ohms (Ω) k=1000 Ω , M=1000k Ω

All capacitors are in MICRO FARADS (μ F) p= μ μ F

*Type & Wattage of Resistor

Type

| | | |
|--------------------------------------|---|--|
| ERC:Solid ERDS:Carbon ERJ:Chip | ERX:Metal Film ERG:Metal Oxide ER0:Metal Film | PQ4R:Chip ERS:Fusible Resistor ERF:Cement Resistor |
|--------------------------------------|---|--|

Wattage

| | | | | | |
|------------|------------|---------|------|------|------|
| 10,16:1/8W | 14,25:1/4W | 12:1/2W | 1:1W | 2:2W | 3:3W |
|------------|------------|---------|------|------|------|

*Type & Voltage Of Capacitor

Type

| | |
|---|--|
| ECFD:Semi-Conductor ECQS:Styrol ECUV,PQCUV, ECUE:Chip ECQMS:Mica | ECCD,ECKD,ECBT,F1K,ECUV: Ceramic ECQE,ECQV,ECQG:Polyester ECEA,ECST,EEE:Electlytic ECQP:Polypropylene |
|---|--|

Voltage

| ECQ Type | ECQG ECQV Type | ECSZ Type | Others | | |
|---|----------------------------|---|---|---|--|
| 1H:50V 2A:100V 2E:250V 2H:500V | 05:50V 1:100V 2:200V | 0F:3.15V 1A:10V 1V:35V 0J:6.3V | 0J :6.3V 1A :10V 1C :16V 1E,25:25V | 1V :35V 50,1H:50V 1J :16V 2A :100V | |

16.5.1. Base Unit

16.5.1.1. Cabinet and Electrical Parts

| Safety | Ref. No. | Part No. | Part Name & Description | Remarks |
|--------|----------|--------------|---------------------------|---------|
| | 1 | PNGP1133Z1 | PANEL, LCD | PC-HB |
| | 2 | PNGP1134Z1 | PANEL, UPPER | PC-HB |
| | 3 | PNLA1046Z | ANTENNA, LOOP | |
| | 4 | PNJK1102Z | KEYBOARD SWITCH, HEAD-SET | |
| | 5 | PNKM1181Y2 | CABINET BODY | PS-HB |
| | 6 | LOAA04A00028 | SPEAKER | |
| | 7 | PQHR11082Z | GUIDE, SPEAKER | POM-HB |
| | 8 | PNKE1089Z2 | CASE, CHARGE TERMINAL | PS-HB |
| | 9 | PNJT1061Z | CHARGE TERMINAL | |
| | 10 | PNBC1346Z1 | BUTTON, NAVIGATOR KEY | ABS-HB |
| | 11 | PNBC1348Z1 | BUTTON, ERASE | PS-HB |

| Safety | Ref. No. | Part No. | Part Name & Description | Remarks |
|--------|----------|--------------|----------------------------|---------|
| | 12 | PNBC1347Z1 | BUTTON, ANSWER ON | PS-HB |
| | 13 | PNBC1349Z1 | BUTTON, STOP | PS-HB |
| | 14 | PNBC1350Z1 | BUTTON, LOCATOR | PS-HB |
| | 15 | PNHR1381Z | GUIDE, BUTTON | PS-HB |
| | 16 | PNBC1345Z1 | BUTTON, MESSAGE | PS-HB |
| | 17 | PNJK1101Z | KEYBOARD SWITCH, TAM | |
| | 18 | PNJK1100Z | KEYBOARD SWITCH, DIAL | |
| | 19 | PNYE1038Z | SPACER, CUSHION LCD | |
| | 20 | PNBC1351Z1 | BUTTON, CELL 1 | PS-HB |
| | 21 | PNBC1352Z1 | BUTTON, CELL 2 | PS-HB |
| | 22 | PNLA1047Z | ANTENNA, SUB | |
| | 23 | PNLA1052Z | ANTENNA, BT | |
| | 24 | PQMG10025W | RUBBER PARTS, MIC | |
| | 25 | PNHR1383Z | GUIDE, JACK | PS-HB |
| | 26 | K2ECYZ000001 | JACK, DC | |
| | 27 | PQJJ1T039L | JACK, MODULAR | |
| | 28 | PNKF1131Z1 | CABINET COVER | PS-HB |
| | 29 | PQHA10023Z | RUBBER PARTS, FOOT CUSHION | |
| | 30 | PNGT5518Z | NAME PLATE | |
| | 31 | PNHR1249Z | PLASTIC PARTS | POM-HB |
| | 32 | PNKL1027Z1 | STAND, WALL MOUNT | PS-HB |

16.5.1.2. Main P.C. Board Parts

Note:

(*1) When replacing IC611 or X501, make the adjustment using PNZZTG7621M. Refer to **How to download the data** (P.64) of Things to Do after Replacing IC or X'tal.

(*2) When replacing the base unit LCD, See **How to Replace the Base unit LCD** (P.54).

| Safety | Ref. No. | Part No. | Part Name & Description | Remarks |
|--------|----------|--------------|-------------------------------------|---------|
| | PCB1 | PNWP1TG7641H | MAIN P.C.BOARD ASS'Y (RTL) (ICs) | |
| | IC302 | C0CBAYG00016 | IC | |
| | IC351 | C0EBE0000124 | IC | |
| | IC381 | C0CBCCC00103 | IC | |
| | IC501 | C1CB00003542 | IC | |
| | IC502 | PNWI2TG7621H | IC (FLASH) | |
| | IC601 | PNWI3TG7621H | IC (FLASH) | |
| | IC611 | PNWI1TG7641H | IC (EEPROM) (*1) | |
| | IC751 | COJBAQ000247 | IC | |
| | | | (TRANSISTORS) | |
| | Q141 | BLACGP000008 | TRANSISTOR(SI) | |
| | Q142 | BLABDM000001 | TRANSISTOR(SI) | |
| | Q161 | DSC7003S0L | TRANSISTOR(SI) | |
| | Q301 | BLADGE000012 | TRANSISTOR(SI) | |
| | Q302 | BLADGE000012 | TRANSISTOR(SI) | |
| | Q351 | BLADNB000003 | TRANSISTOR(SI) | |
| | Q352 | BLABDF000017 | TRANSISTOR(SI) | |
| | Q354 | BLGBCFYY0010 | TRANSISTOR(SI) | |
| | Q361 | BLABDF000017 | TRANSISTOR(SI) | |
| | Q362 | BLGBCFYY0020 | TRANSISTOR(SI) | |
| | Q363 | BLABDF000017 | TRANSISTOR(SI) | |
| | Q601 | BLABDF000017 | TRANSISTOR(SI) | |
| | Q651 | BLGFCFEN0011 | TRANSISTOR(SI) | |
| | Q652 | BLGFCFEN0011 | TRANSISTOR(SI) | |
| | Q654 | BLGFCFEN0011 | TRANSISTOR(SI) | |
| | Q701 | 2SA1576S | TRANSISTOR(SI) | S |
| | Q702 | BLGBCFYY0020 | TRANSISTOR(SI) | |
| | Q731 | PQVTDTC114TU | TRANSISTOR(SI) | S |
| | Q732 | PQVTDTC114TU | TRANSISTOR(SI) | S |
| | Q733 | PQVTDTC114TU | TRANSISTOR(SI) | S |
| | | | (DIODES) | |
| | D101 | PQVDM5S | DIODE(SI) | |
| | D133 | 1SS355 | DIODE(SI) | S |
| | D142 | PQVDPZT2530 | DIODE(SI) | S |
| | D362 | BOECKM000008 | DIODE(SI) | |
| | DA801 | BODDCD000001 | DIODE(SI) | |
| | DA802 | BODDCD000001 | DIODE(SI) | |

| Safety | Ref. No. | Part No. | Part Name & Description | Remarks |
|--------|----------|--------------|---------------------------|---------|
| | | | (COILS) | |
| | L101 | PQLQXF330K | COIL | S |
| | L102 | PQLQXF330K | COIL | S |
| | L351 | PQLQR2KA113 | COIL | S |
| | L381 | PQLQR2KA113 | COIL | S |
| | L802 | G1C4N7Z00006 | COIL | |
| | L803 | G1C4N7Z00006 | COIL | |
| | | | (RESISTOR ARRAYS) | |
| | RA451 | D1H422220001 | RESISTOR ARRAY | |
| | RA452 | D1H427220001 | RESISTOR ARRAY | |
| | RA501 | D1H422120001 | RESISTOR ARRAY | |
| | RA651 | D1H81024A024 | RESISTOR ARRAY | |
| | RA652 | D1H81024A024 | RESISTOR ARRAY | |
| | RA653 | D1H81024A024 | RESISTOR ARRAY | |
| | RA721 | D1H81024A024 | RESISTOR ARRAY | |
| | | | (IC FILTER) | |
| | R659 | J0JCC0000286 | IC FILTER | |
| | | | (BT UNIT) | |
| | IC721 | PNWP3TG7621H | BT UNIT | |
| | | | (VARISTOR) | |
| | SA101 | J0LF00000048 | VARIATOR (SURGE ABSORBER) | |
| | | | (RESISTORS) | |
| | R101 | PQ4R10XJ475 | 4.7M | S |
| | R102 | PQ4R10XJ475 | 4.7M | S |
| | R103 | PQ4R10XJ184 | 180k | S |
| | R104 | PQ4R10XJ184 | 180k | S |
| | R105 | PQ4R10XJ105 | 1M | S |
| | R106 | PQ4R10XJ105 | 1M | S |
| | R107 | D0GA102JA021 | 1k | |
| | R108 | D0GA102JA021 | 1k | |
| | R109 | ERJ2GEJ823 | 82k | S |
| | R110 | ERJ2GEJ823 | 82k | S |
| | R111 | D0GA392JA015 | 3.9k | |
| | R112 | D0GA124JA015 | 120k | |
| | R121 | D0GA102JA021 | 1k | |
| | R122 | D0GA102JA021 | 1k | |
| | R123 | D0GA102JA021 | 1k | |
| | R125 | D0GA271JA015 | 270 | |
| | R131 | PQ4R18XJ106 | 10M | S |
| | R133 | ERJ3GEYJ154 | 150k | S |
| | R141 | D0GB104JA057 | 100k | |
| | R142 | PQ4R18XJ272 | 2.7k | S |
| | R144 | D0GB103JA057 | 10k | |
| | R145 | D0GA222JA021 | 2.2k | |
| | R151 | D0GA104JA021 | 100k | |
| | R152 | ERJ2GEJ474X | 470k | S |
| | R160 | ERJ3GEYJ911 | 910 | S |
| | R161 | D0GB104JA057 | 100k | |
| | R162 | D0GB473JA057 | 47k | |
| | R163 | ERJ12YJ120 | 12 | |
| | R164 | D0GB272JA057 | 2.7k | |
| | R165 | ERJ3GEYJ273 | 27k | S |
| | R166 | ERJ3GEYJ822 | 8.2k | S |
| | R167 | ERJ12YJ270 | 27 | |
| | R178 | D0GA332JA015 | 3.3k | |
| | R301 | PQ4R10XJ000 | 0 | S |
| | R311 | D0GA103JA021 | 10k | |
| | R312 | D0GA103JA021 | 10k | |
| | R321 | ERJ2RKF1400 | 140 | |
| | R322 | ERJ2RKF1000 | 100 | |
| | R351 | D0GA392JA015 | 3.9k | |
| | R352 | ERJ2GEJ563 | 56k | S |
| | R353 | D0GA103JA021 | 10k | |
| | R354 | D0GA103JA021 | 10k | |
| | R355 | D0GA681JA021 | 680 | |
| | R358 | D0GA103JA021 | 10k | |
| | R359 | D0GA103JA021 | 10k | |
| | R360 | ERJ2GEJ563 | 56k | S |
| | R361 | PQ4R10XJ121 | 120 | S |
| | R362 | PQ4R10XJ121 | 120 | S |
| | R363 | D0GA332JA015 | 3.3k | |
| | R364 | D0GA103JA021 | 10k | |

| Safety | Ref. No. | Part No. | Part Name & Description | Remarks |
|--------|----------|--------------|-------------------------|---------|
| | R365 | D0GA473JA021 | 47k | |
| | R366 | D0GA103JA021 | 10k | |
| | R371 | ERJ12YJ1R0 | 1 | |
| | R372 | ERJ12YJ1R0 | 1 | |
| | R373 | D0GA182JA015 | 1.8k | |
| | R451 | ERJ2GEYJ391 | 390 | S |
| | R474 | D0GA1R0JA014 | 1 | |
| | R475 | D0GA1R0JA014 | 1 | |
| | R501 | D0GA563ZA006 | 56k | |
| | R502 | D0GA332JA015 | 3.3k | |
| | R504 | D0GA103JA021 | 10k | |
| | R505 | D0GA102JA021 | 1k | |
| | R506 | D0GA101JA021 | 100 | |
| | R507 | D0GA104JA021 | 100k | |
| | R508 | ERJ2GEJ100 | 10 | S |
| | R515 | D0GA473JA021 | 47k | |
| | R516 | D0GA473JA021 | 47k | |
| | R517 | D0GA473JA021 | 47k | |
| | R601 | D0GA332JA015 | 3.3k | |
| | R602 | D0GA561JA021 | 560 | |
| | R603 | D0GA561JA021 | 560 | |
| | R604 | D0GA561JA021 | 560 | |
| | R605 | D0GA473JA021 | 47k | |
| | R606 | D0GA103JA021 | 10k | |
| | R611 | D0GA103JA021 | 10k | |
| | R612 | D0GA332JA015 | 3.3k | |
| | R613 | D0GA332JA015 | 3.3k | |
| | R651 | D0GA122JA015 | 1.2k | |
| | R652 | D0GA181JA021 | 180 | |
| | R653 | D0GA181JA021 | 180 | |
| | R654 | D0GA181JA021 | 180 | |
| | R656 | D0GA102JA021 | 1k | |
| | R657 | D0GA102JA021 | 1k | |
| | R658 | D0GA102JA021 | 1k | |
| | R662 | D0GA681JA021 | 680 | |
| | R663 | D0GA681JA021 | 680 | |
| | R664 | D0GA681JA021 | 680 | |
| | R665 | D0GA103JA021 | 10k | |
| | R668 | D0GA561JA021 | 560 | |
| | R669 | D0GA102JA021 | 1k | |
| | R671 | D0GA473JA021 | 47k | |
| | R672 | D0GA473JA021 | 47k | |
| | R673 | D0GA473JA021 | 47k | |
| | R701 | ERJ3GEYJ332 | 3.3k | S |
| | R702 | D0GA103JA021 | 10k | |
| | R703 | D0GA102JA021 | 1k | |
| | R721 | ERJ2GEJ474X | 470k | S |
| | R731 | D0GA103JA021 | 10k | |
| | R733 | D0GA103JA021 | 10k | |
| | R734 | D0GA103JA021 | 10k | |
| | R751 | D0GA102JA021 | 1k | |
| | R752 | D0GA102JA021 | 1k | |
| | R781 | ERJ2GEOR00 | 0 | S |
| | R806 | D0GA221JA021 | 220 | |
| | R807 | D0GA221JA021 | 220 | |
| | R891 | D0GA221JA021 | 220 | |
| | R892 | D0GA221JA021 | 220 | |
| | | | (CAPACITORS) | |
| | C101 | F1K2H681A008 | 680p | |
| | C102 | F1K2H681A008 | 680p | |
| | C103 | ECUV1C103KBV | 0.01 | |
| | C104 | ECUV1C103KBV | 0.01 | |
| | C105 | F1K2H681A008 | 680p | |
| | C106 | F1K2H681A008 | 680p | |
| | C107 | ECUV1C103KBV | 0.01 | |
| | C108 | ECUV1C103KBV | 0.01 | |
| | C109 | ECUE1H821KBQ | 820p | |
| | C110 | ECUE1H821KBQ | 820p | |
| | C111 | ECUE1A333KBQ | 0.033 | S |
| | C112 | ECUE1H100DCQ | 10p | S |
| | C113 | ECUE1A823KBQ | 0.082 | S |
| | C123 | ECUE1H100DCQ | 10p | S |
| | C124 | ECUE1H100DCQ | 10p | S |

| Safety | Ref. No. | Part No. | Part Name & Description | Remarks |
|--------|----------|--------------|-------------------------|---------|
| | C125 | ECUE1H100DCQ | 10p | S |
| | C132 | ECUV1H103KBV | 0.01 | |
| | C142 | ECUV1H103KBV | 0.01 | |
| | C152 | ECUE1C103KBQ | 0.01 | S |
| | C161 | EEE1HA100SP | 10 | |
| | C167 | ECUV1H102KBV | 0.001 | |
| | C171 | ECUV1C223KBV | 0.022 | |
| | C172 | ECUE1H100DCQ | 10p | S |
| | C173 | ECUE1A104KBQ | 0.1 | |
| | C184 | ECUV1C105KBV | 1 | |
| | C186 | ECUE1H100DCQ | 10p | S |
| | C306 | F2A1C1010119 | 100 | |
| | C311 | ECUV1C105KBV | 1 | |
| | C312 | ECUV1C105KBV | 1 | |
| | C321 | ECUV1A105KBV | 1 | |
| | C341 | F2A0J1020031 | 1000 | |
| | C342 | ECUE1A104KBQ | 0.1 | |
| | C343 | ECUE1H100DCQ | 10p | S |
| | C344 | EEE0JA221WP | 220 | |
| | C345 | EEE0JA221WP | 220 | |
| | C351 | ECUV1C105KBV | 1 | |
| | C381 | ECUV1C105KBV | 1 | |
| | C383 | ECUV1C105KBV | 1 | |
| | C451 | PQCUV0J106KB | 10 | S |
| | C452 | ECUE1H100DCQ | 10p | S |
| | C454 | ECUE1H100DCQ | 10p | S |
| | C455 | ECUE1H100DCQ | 10p | S |
| | C457 | ECUE1C333KBQ | 0.033 | S |
| | C458 | ECUE1C333KBQ | 0.033 | S |
| | C459 | ECUE1H102KBQ | 0.001 | S |
| | C460 | ECUE1H100DCQ | 10p | S |
| | C461 | ECUE1H100DCQ | 10p | S |
| | C472 | ECUE1H100DCQ | 10p | S |
| | C473 | ECUE1H100DCQ | 10p | S |
| | C474 | ECUE1H222KBQ | 0.0022 | S |
| | C475 | ECUE1H222KBQ | 0.0022 | S |
| | C476 | ECUE1H151JCQ | 150p | |
| | C477 | ECUE1H100DCQ | 10p | S |
| | C478 | ECUE1H100DCQ | 10p | S |
| | C479 | ECUE1H151JCQ | 150p | |
| | C501 | ECUE1A104KBQ | 0.1 | |
| | C502 | ECUE0J105KBQ | 1 | |
| | C503 | ECUE1H100DCQ | 10p | S |
| | C504 | ECUE1A104KBQ | 0.1 | |
| | C505 | ECUE1A104KBQ | 0.1 | |
| | C506 | ECUV1A225KBV | 2.2 | S |
| | C507 | ECUV1A105KBV | 1 | |
| | C508 | ECUV1A105KBV | 1 | |
| | C509 | ECUV0J225KBV | 2.2 | S |
| | C511 | ECUV1A105KBV | 1 | |
| | C513 | ECUE1A104KBQ | 0.1 | |
| | C516 | ECUE1A104KBQ | 0.1 | |
| | C517 | ECUE1A104KBQ | 0.1 | |
| | C518 | ECUE1A104KBQ | 0.1 | |
| | C519 | ECUE1A104KBQ | 0.1 | |
| | C601 | ECUE1A104KBQ | 0.1 | |
| | C603 | ECUE1C103KBQ | 0.01 | S |
| | C611 | ECUE1A104KBQ | 0.1 | |
| | C661 | ECUE1A104KBQ | 0.1 | |
| | C670 | ECUE1C103KBQ | 0.01 | S |
| | C701 | ECUE1H102KBQ | 0.001 | S |
| | C721 | ECUE1A104KBQ | 0.1 | |
| | C751 | ECUE1A104KBQ | 0.1 | |
| | C802 | FIG1HR8A480 | 1.8p | |
| | C803 | FIG1HR5A480 | 1.5p | |
| | C804 | FIG1HR8A480 | 1.8p | |
| | C805 | FIG1H2R4A480 | 2.4p | |
| | C806 | FIG1H2R4A480 | 2.4p | |
| | C809 | ECUE1H100DCQ | 10p | S |
| | C810 | FIG1HR0A480 | 1p | |
| | C811 | ECUE1H100DCQ | 10p | S |
| | C812 | FIG1HR0A480 | 1p | |
| | C813 | FIG1HR0A480 | 1p | |

| Safety | Ref. No. | Part No. | Part Name & Description | Remarks |
|--------|----------|--------------|-----------------------------|---------|
| | C820 | FIG1HR70A480 | 0.7p | |
| | C822 | ECUE1H100DCQ | 10p | S |
| | C823 | ECUE1H101JCQ | 100p | |
| | C825 | ECUE1H100DCQ | 10p | S |
| | C826 | ECUE1H100DCQ | 10p | S |
| | C837 | FIG1HR90A480 | 0.9p | |
| | C842 | FIG1HR0A480 | 1p | |
| | C843 | FIG1H3R0A480 | 3p | |
| | C844 | FIG1HR5A480 | 1.5p | |
| | C851 | FIG1H7R0A480 | 7p | |
| | C853 | FIG1H7R0A480 | 7p | |
| | C855 | ECUE1H100DCQ | 10p | S |
| | C856 | ECUE1H101JCQ | 100p | |
| | C857 | ECUE1H100DCQ | 10p | S |
| | C858 | ECUE1H101JCQ | 100p | |
| | C863 | FIG1H7R0A480 | 7p | |
| | C864 | FIG1H7R0A480 | 7p | |
| | | | (OTHERS) | |
| | E1 | L5DYBY00020 | LIQUID CRYSTAL DISPLAY (*2) | |
| | E2 | PNHX1379Z | COVER, LCD | |
| | E3 | PNHR1384Z | TRANSPARENT PLATE, LCD | PMMA-HB |
| | E4 | PNHR1382Z | GUIDE, LCD | ABS-HB |
| | P101 | D4DAY220A022 | THERMISTOR (POSISTOR) | |
| | F301 | K5H302Y00003 | FUSE | |
| | X501 | H0J103500037 | CRYSTAL OSCILLATOR (*1) | |

16.5.1.3. Operational P.C. Board Parts

| Safety | Ref. No. | Part No. | Part Name & Description | Remarks |
|--------|----------|--------------|-----------------------------------|---------|
| | PCB2 | PNWP2TG7641H | OPERATIONAL P.C.BOARD ASS'Y (RTL) | |
| | | | (LEDS) | |
| | LED901 | LNJ237W82RA | LED | |
| | LED902 | LNJ237W82RA | LED | |
| | LED904 | LNJ237W82RA | LED | |
| | LED911 | LNJ237W82RA | LED | |
| | LED912 | B3ABB0000331 | LED | |
| | LED913 | LNJ237W82RA | LED | |
| | LED914 | B3ABB0000331 | LED | |
| | LED915 | LNJ237W82RA | LED | |
| | LED916 | B3ABB0000331 | LED | |
| | | | (RESISTORS) | |
| | R907 | ERJ3GEYJ101 | 100 | S |
| | R908 | ERJ3GEYJ101 | 100 | S |
| | | | (CAPACITORS) | |
| | C902 | ECUE0J105KBQ | 1 | |
| | C903 | ECUV1C105KBV | 1 | |
| | | | (OTHER) | |
| | MIC1 | L0CBAY000018 | MICROPHONE | |

16.5.1.4. LED Board Parts

| Safety | Ref. No. | Part No. | Part Name & Description | Remarks |
|--------|----------|--------------|---------------------------|---------|
| | PCB3 | PNWP3TG6641H | LED P.C.BOARD ASS'Y (RTL) | |
| | | | (LED) | |
| | WLED | B3AFB0000370 | LED | |

16.5.2. Handset

16.5.2.1. Cabinet and Electrical Parts

| Safety | Ref. No. | Part No. | Part Name & Description | Remarks |
|--------|----------|------------|----------------------------------|---------|
| | 101 | PNGP1136Z1 | PANEL, LCD | PMMA-HB |
| | 102 | PNYE1041Z | TAPE, DOUBLE SIDED | |
| | 103 | PNKM1184Y2 | CABINET BODY | ABS-HB |
| | 104 | PNHR1390Z | OPTIC CONDUCTIVE PARTS, LED LENS | PS-HB |

| Safety | Ref. No. | Part No. | Part Name & Description | Remarks |
|--------|----------|--------------|-------------------------|---------|
| | 105 | L0AD01A00026 | RECEIVER | |
| | 106 | PNYE1040Z | SPACER, CUSHION LCD | |
| | 107 | PNBC1354Z1 | BUTTON, NAVIGATOR KEY | ABS-HB |
| | 108 | PNJK1104Y | KEYBOARD SWITCH | |
| | 109 | PNJT1057Z | CHARGE TERMINAL (L) | |
| | 110 | PNJT1058Z | CHARGE TERMINAL (R) | |
| | 111 | PQHR11315Z | GUIDE, SPEAKER | ABS-HB |
| | 112 | L0AA02A00095 | SPEAKER | |
| | 113 | PQHS10784Y | SPACER, SPEAKER NET | |
| | 114 | PQJC10056W | BATTERY TERMINAL | |
| | 115 | PNKE1091Z2 | COVER, EP CAP | |
| | 116 | PNKF1133Y2 | CABINET COVER | ABS-HB |
| | 117 | PNKE1092Z2 | COVER, RUBBER GRIP | |
| | 118 | PNQT2006Z | LABEL, ATTENTION | |
| | 119 | PNQT2062Z | LABEL, BATTERY | |
| | 120 | PNGT5515Y | NAME PLATE | |
| | 121 | PNHS1079Z | SPACER, BATTERY | |
| | 122 | PNKK1052Y2 | LID, BATTERY | ABS-HB |
| | 123 | PNYNTGA660MR | LID, BATTERY ASS'Y | ABS-HB |

16.5.2.2. Main P.C. Board Parts

Note:

- (*1) Reconfirm the model No. written on the handset's name plate when replacing PCB100. Because the model No. of the optional handset may differ from the included handset.
- (*2) When replacing IC3 or X1, make the adjustment using PNZZTG7621M. Refer to **Handset** (P.65) of Things to Do after Replacing IC or X'tal.
- (*3) When replacing the handset LCD, See **How to Replace the Handset LCD** (P.56).

| Safety | Ref. No. | Part No. | Part Name & Description | Remarks |
|--------|----------|--------------|---------------------------------|---------|
| | PCB100 | PNWP1TGA660R | MAIN P.C.BOARD ASS'Y (RTL) (*1) | |
| | | | (ICs) | |
| | IC1 | C2HBCY000081 | IC | |
| | IC3 | PNWITGA660BR | IC (EEPROM) (*2) | |
| | IC4 | C0DBZYY00357 | IC | |
| | | | (TRANSISTORS) | |
| | Q2 | B1ADCF000040 | TRANSISTOR (SI) | |
| | Q3 | B1ABGE000011 | TRANSISTOR (SI) | |
| | Q4 | B1ADCF000040 | TRANSISTOR (SI) | |
| | Q5 | B1GBCFYY0010 | TRANSISTOR (SI) | |
| | Q6 | B1GBCFYY0010 | TRANSISTOR (SI) | |
| | Q9 | B1ABDF000017 | TRANSISTOR (SI) | |
| | Q10 | B1ADNB000003 | TRANSISTOR (SI) | |
| | Q11 | B1ABDF000017 | TRANSISTOR (SI) | |
| | Q12 | B1ADCF000040 | TRANSISTOR (SI) | |
| | | | (DIODES) | |
| | D13 | B0BC4R3A0006 | DIODE (SI) | S |
| | D14 | B0BC4R3A0006 | DIODE (SI) | S |
| | D21 | B0BC4R3A0006 | DIODE (SI) | S |
| | D22 | B0BC4R3A0006 | DIODE (SI) | S |
| | DA801 | B0DDCD000001 | DIODE (SI) | |
| | | | (LEDS) | |
| | LED1 | B3ACB0000216 | LED | |
| | LED2 | B3ACB0000216 | LED | |
| | LED3 | B3ACB0000216 | LED | |
| | LED4 | B3ACB0000216 | LED | |
| | LED5 | B3ACB0000216 | LED | |
| | LED6 | B3ACB0000216 | LED | |
| | LED12 | B3ACB0000216 | LED | |
| | | | (COILS) | |
| | C812 | PQLQR4C8N2J | COIL | S |
| | L13 | G1CR18J00004 | COIL | |
| | | | (RESISTOR ARRAYS) | |
| | RA2 | D1H83314A013 | RESISTOR ARRAY | S |
| | RA3 | D1H433120001 | RESISTOR ARRAY | |
| | RA4 | D1H433220001 | RESISTOR ARRAY | |
| | RA5 | EXB28V332JX | RESISTOR ARRAY | |

| Safety | Ref. No. | Part No. | Part Name & Description | Remarks |
|--------|----------|--------------|-------------------------|---------|
| | | | (IC FILTERS) | |
| | L29 | J0JDC0000045 | IC FILTER | |
| | L72 | J0JCC0000276 | IC FILTER | |
| | R308 | J0JCC0000286 | IC FILTER | |
| | | | (RESISTORS) | |
| | R2 | ERJ2GEJ303 | 30k | S |
| | R3 | ERJ2GEJ152 | 1.5k | S |
| | R4 | ERJ2GEJ473 | 47k | S |
| | R6 | ERJ2GEJ103 | 10k | S |
| | R7 | ERJ2GEJ104 | 100k | S |
| | R8 | ERJ8GEYJ3R3 | 3.3 | S |
| | R9 | ERJ2GEJ303 | 30k | S |
| | R10 | ERJ3GEYJ1R0 | 1 | S |
| | R11 | ERJ2GEJ681 | 680 | S |
| | R12 | ERJ2GEJ183 | 18k | S |
| | R13 | ERJ2GEJ103 | 10k | S |
| | R19 | ERJ2RKF2003 | 200k | |
| | R20 | ERJ2RKF1003 | 100k | |
| | R21 | ERJ2RKF1003 | 100k | |
| | R22 | ERJ2GEJ332 | 3.3k | S |
| | R23 | ERJ2GEJ100 | 10 | S |
| | R24 | ERJ2GEJ391 | 390 | S |
| | R25 | ERJ2GEJ222 | 2.2k | S |
| | R26 | ERJ2GEJ332 | 3.3k | S |
| | R27 | ERJ2GEJ222 | 2.2k | S |
| | R28 | ERJ2GEJ222 | 2.2k | S |
| | R31 | ERJ2RKF1003 | 100k | |
| | R32 | ERJ2GEJ104 | 100k | S |
| | R33 | ERJ2RKF1003 | 100k | |
| | R34 | ERJ2GEJ391 | 390 | S |
| | R45 | ERJ6RSJR10V | 0.1 | |
| | R64 | ERJ2GEJ222 | 2.2k | S |
| | R66 | ERJ2GEJ103 | 10k | S |
| | R67 | ERJ2GEJ103 | 10k | S |
| | R68 | ERJ2GEJ103 | 10k | S |
| | R69 | ERJ2GEJ103 | 10k | S |
| | R73 | ERJ2GEJ330 | 33 | S |
| | R74 | ERJ2GEJ330 | 33 | S |
| | R306 | ERJ2GEJ101 | 100 | S |
| | R509 | ERJ2GEJ560X | 56 | S |
| | R561 | ERJ2GEJ221 | 220 | S |
| | R563 | ERJ2GEOR00 | 0 | S |
| | R806 | ERJ2GEJ471 | 470 | S |
| | R807 | ERJ2GEJ471 | 470 | S |
| | L9 | ERJ2GEOR00 | 0 | S |
| | L74 | ERJ2GEJ100 | 10 | S |
| | | | (CAPACITORS) | |
| | C1 | EEE0JA221WP | 220 | |
| | C2 | EEE0JA221WP | 220 | |
| | C4 | ECUE1H390JCQ | 39p | |
| | C5 | ECUE1A104KBQ | 0.1 | |
| | C8 | ECUE1H100DCQ | 10p | |
| | C9 | ECUE1H120JCQ | 12p | |
| | C10 | EEE0JA221WP | 220 | |
| | C11 | ECUE1A104KBQ | 0.1 | |
| | C12 | PQCUV0J106KB | 10 | |
| | C13 | ECUE1A104KBQ | 0.1 | |
| | C14 | ECUV1C393KEV | 0.039 | |
| | C15 | ECUE1H390JCQ | 39p | |
| | C16 | ECUV1C393KEV | 0.039 | |
| | C17 | ECUE1H100DCQ | 10p | |
| | C18 | ECUE1H100DCQ | 10p | |
| | C19 | ECUE1H102KBQ | 0.001 | |
| | C20 | ECJ1VB0G106M | 10 | S |
| | C21 | ECUV1A105KBV | 1 | |
| | C22 | ECUE1A104KBQ | 0.1 | |
| | C23 | ECUE1A104KBQ | 0.1 | |
| | C24 | ECUE0J105KBQ | 1 | |
| | C25 | ECUV1A225KEV | 2.2 | |
| | C26 | ECJ1VB0G106M | 10 | S |
| | C29 | ECUV1A105KBV | 1 | |
| | C30 | ECJ1VB0G106M | 10 | S |
| | C31 | ECUE0J105KBQ | 1 | |

| Safety | Ref. No. | Part No. | Part Name & Description | Remarks |
|--------|----------|--------------|-----------------------------|---------|
| | C32 | ECUE0J105KBQ | 1 | |
| | C33 | ECUE1A104KBQ | 0.1 | |
| | C34 | ECUE1H390JCQ | 39p | |
| | C36 | ECUE1A104KBQ | 0.1 | |
| | C37 | ECJ1VB0G106M | 10 | S |
| | C40 | ECUE1A104KBQ | 0.1 | |
| | C41 | ECUE1A104KBQ | 0.1 | |
| | C43 | ECUE1A104KBQ | 0.1 | |
| | C44 | ECUE0J105KBQ | 1 | |
| | C45 | ECUE1A104KBQ | 0.1 | |
| | C46 | ECUE1H100DCQ | 10p | S |
| | C51 | ECJ1VB0G106M | 10 | S |
| | C56 | ECUV1A105KBV | 1 | |
| | C57 | ECUV1A105KBV | 1 | |
| | C58 | ECUE0J105KBQ | 1 | |
| | C72 | ECUE1H100DCQ | 10p | |
| | C73 | ECUE1H100DCQ | 10p | |
| | C76 | ECUE1H100DCQ | 10p | |
| | C77 | ECUE1H100DCQ | 10p | |
| | C78 | ECUE1H390JCQ | 39p | |
| | C79 | ECUE1H101JCQ | 100p | |
| | C80 | ECUE1H390JCQ | 39p | |
| | C81 | ECUE1H101JCQ | 100p | |
| | C82 | ECUE1H471KBQ | 470p | |
| | C83 | ECUE1H100DCQ | 10p | |
| | C86 | F1J0J2260002 | 22 | |
| | C96 | ECUE1H100DCQ | 10p | |
| | C97 | ECUE1H100DCQ | 10p | |
| | C110 | ECUE1H102KBQ | 0.001 | |
| | C127 | ECUE1H102KBQ | 0.001 | |
| | C150 | ECUE1A104KBQ | 0.1 | |
| | C152 | ECUE1H102KBQ | 0.001 | |
| | C172 | ECUE1A104KBQ | 0.1 | |
| | C183 | ECUE1H100DCQ | 10p | |
| | C184 | ECUE1H100DCQ | 10p | |
| | C185 | ECUE1H102KBQ | 0.001 | |
| | C188 | ECUE0J105KBQ | 1 | |
| | C504 | ECUV1C105KBV | 1 | |
| | C505 | ECUE0J105KBQ | 1 | |
| | C805 | F1G1H2R4A480 | 2.4p | |
| | C806 | F1G1H2R4A480 | 2.4p | |
| | C810 | F1G1H2R5A480 | 2.5p | |
| | C811 | ECUE1H101JCQ | 100p | S |
| | C813 | F1G1H1R6A480 | 1.6p | |
| | C820 | F1G1H1R8A480 | 1.8p | |
| | C822 | ECUE1H100DCQ | 10p | S |
| | C825 | ECUE1H100DCQ | 10p | S |
| | C826 | ECUE1H100DCQ | 10p | S |
| | C859 | F1G1H2R0A480 | 2p | |
| | C863 | F1G1H1R8A480 | 1.8p | |
| | C895 | F1G1H1R3A480 | 1.3p | |
| | C896 | F1G1H1R8A480 | 1.8p | |
| | C897 | F1G1H240A557 | 24p | |
| | L809 | F1G1H1R0A480 | 1p | |
| | | (OTHERS) | | |
| | MIC100 | L0CBAY000053 | MICROPHONE | |
| | E101 | L5DYBY000001 | LIQUID CRYSTAL DISPLAY (*3) | |
| | E102 | PNHR1295Z | TRANSPARENT PLATE, LCD | PMMA-HB |
| | E103 | PNHR1389Z | GUIDE, LCD | ABS-HB |
| | E104 | PNHX1407Z | COVER, LCD | |
| | E105 | PNLA1049Z | ANTENNA | |
| | E106 | PNVE1002Z | BATTERY TERMINAL | ABS-HB |
| | E107 | PQHGI0729Z | RUBBER PARTS, RECEIVER | |
| | CN4 | K2HD103D0001 | JACK | |
| △ | F1 | K5H252Y00002 | FUSE | |
| | X1 | H0J138500003 | CRYSTAL OSCILLATOR (*2) | S |

16.5.2.3. LED Board Parts

| Safety | Ref. No. | Part No. | Part Name & Description | Remarks |
|--------|----------|--------------|---------------------------|---------|
| | PCB101 | PNWP2TGA660R | LED P.C.BOARD ASS'Y (RTL) | |
| | | | (LED) | |
| | WLED | B3AFB0000370 | LED | |

16.5.3. Charger Unit

16.5.3.1. Cabinet and Electrical Parts

| Safety | Ref. No. | Part No. | Part Name & Description | Remarks |
|--------|----------|------------|---|---------|
| | 200 | PNLC1017ZM | CHARGER UNIT ASS'Y without NAME PLATE (RTL) | |
| | 200-1 | PNKM1201Y2 | CABINET BODY | PS-HB |
| | 200-2 | PNJT1065Z | CHARGE TERMINAL | |
| | 200-3 | PNKF1147Z1 | CABINET COVER | PS-HB |
| | 200-4 | PQHA10023Z | RUBBER PARTS, FOOT CUSHION | |
| | 201 | PNGT5532Z | NAME PLATE | |

16.5.3.2. Main P.C. Board Parts

| Safety | Ref. No. | Part No. | Part Name & Description | Remarks |
|--------|----------|--------------|----------------------------|---------|
| | PCB200 | PNWPTGA660CH | MAIN P.C.BOARD ASS'Y (RTL) | |
| | | | (JACK) | |
| | J1 | K2ECYB000001 | JACK | S |
| | | | (RESISTOR) | |
| | R1 | ERX2SJ6R8 | 6.8 | |
| | | | (FUSE) | |
| △ | F1 | K5H302Y00003 | FUSE | |

16.5.4. Accessories

Note:

(*1) You can download and refer to the Operating Instructions (Instruction book) on TSN Server.

| Safety | Ref. No. | Part No. | Part Name & Description | Remarks |
|--------|----------|------------|-------------------------|---------|
| △ | A1 | PNLV226Z | AC ADAPTOR | |
| | A2 | PQJA10075Z | CORD, TELEPHONE | |
| | A3 | PNQX3168X | INSTRUCTIONBOOK (*1) | |
| | A4 | PNQW2594Y | LEAFLET, QUICK GUIDE | |
| | A5 | PNKE1098Z2 | HANGER, BELT CLIP | ABS-HB |

16.5.5. Screws

| Safety | Ref. No. | Part No. | Part Name & Description | Remarks |
|--------|----------|------------|-------------------------|---------|
| | A | XTB26+8GFJ | TAPPING SCREW | |
| | B | XTB2+8GFJ | TAPPING SCREW | |

16.5.6. Fixtures and Tools

Note:

- (*1) See **Equipment Required** (P.57), and **The Setting Method of JIG** (P.57)
- (*2) When replacing the Handset LCD, See **How to Replace the Handset LCD** (P.56)

| Safety | Ref. No. | Part No. | Part Name & Description | Remarks |
|--------|----------|-------------|-------------------------------|---------|
| | | PQZZ1CD300E | JIG CABLE (*1) | |
| | | PNZZTG7621M | BATCH FILE CD-ROM (*1) | |
| | | PQZZ430PIR | TIP OF SOLDERING IRON (*2) | |
| | | PQZZ430PRB | RUBBER OF SOLDERING IRON (*2) | |

Service Manual

Telephone Equipment

Model No. **KX-TG155SK**
KX-TGA660M

Link-to-Cell Cellular Convergence
Solution

M: Metallic Grey Version
(for U.S.A.)

Supplement-1

Please file and use this supplement manual together with the service manual for Model No.KX-TG155SK/
KX-TGA660M, Order No. KM41201535CE.

WARNING

This service information is designed for experienced repair technicians only and is not designed for use by the general public. It does not contain warnings or cautions to advise non-technical individuals of potential dangers in attempting to service a product. Products powered by electricity should be serviced or repaired only by experienced professional technicians. Any attempt to service or repair the product or products dealt with in this service information by anyone else could result in serious injury or death.









TABLE OF CONTENTS

| | PAGE |
|--|----------|
| 1 REPLACEMENT PARTS LIST ----- | 2 |
| 1.1. REFERENCE CHART----- | 2 |
| 1.2. ORIGINAL AND NEW PARTS COMPARISON LISTS----- | 2 |

1 REPLACEMENT PARTS LIST

1.1. REFERENCE CHART

| Reason for Change | |
|---|--|
| *The following items (1-8) indicate the reason for change. See the "Notes" column for each part in ORIGINAL AND NEW PARTS COMPARISON LISTS . | |
| 1. Improve performance | Remarks: *c: To share the parts with other models. |
| 2. Change of material or dimension | |
| 3. To meet approved specification | |
| 4. Standardization | |
| 5. Addition | |
| 6. Deletion | |
| 7. Correction | |
| 8. Other | |

| Interchangeability Code | | |
|---|---|--|
| **The following items (V-Z) indicate the Interchangeability. See the "Notes" column for each part in ORIGINAL AND NEW PARTS COMPARISON LISTS . | | |
| V | Original  Early (before change) New  Late (after change) | Original or new parts may be used in early or late production sets. Use original parts until exhausted, then stock new parts. |
| W | Original  Early (before change) New  Late (after change) | Original parts may be used in early production sets only. New parts may be used in early or late production sets. Use original parts where possible, then stock new parts. |
| X | Original  Early (before change) New  Late (after change) | New parts only may be used in early or late production sets. Stock new parts. |
| Y | Original  Early (before change) New  Late (after change) | Original parts may be used in early production sets only. New parts may be used in late production sets only. Stock both original and new parts. |
| Z | Other | |

Note:

Alphabets in the "Remarks" column in the following lists correspond to the alphabets in the "Remarks" in REFERENCE CHART.

1.2. ORIGINAL AND NEW PARTS COMPARISON LISTS

| Ref. No. | Part No. | | Part Name & Description | Pcs/ Set | Remarks | Notes | Time of Change (Suffix) |
|--|----------------|-------|-------------------------|-------------|---------|-------|----------------------------|
| | Original (Old) | New | | | | | |
| Main P.C.Board Parts (Handset) (For PNLPTGA660R1ZA) | | | | | | | |
| C1 | EEE0JA221WP | ----- | CAPACITOR, 220 μ F | 0 | *c | 6 - | --- |
| C10 | EEE0JA221WP | ----- | CAPACITOR, 220 μ F | 0 | *c | 6 - | --- |
| Main P.C.Board Parts (Handset) (For PNLPTGA660R1YA) | | | | | | | |
| C1 | EEE0JA221WP | ----- | CAPACITOR, 220 μ F | 0 | *c | 6 - | --- |
| C10 | EEE0JA221WP | ----- | CAPACITOR, 220 μ F | 0 | *c | 6 - | --- |

Service Manual

Telephone Equipment

Model No. **KX-TG155SK**
KX-TGA660M

Link-to-Cell Cellular Convergence
Solution

M: Metallic Grey Version
(for U.S.A.)

Supplement-2

Please file and use this supplement manual together with the service manual for Model No.KX-TG155SK/
KX-TGA660M, Order No. KM41201535CE.

WARNING

This service information is designed for experienced repair technicians only and is not designed for use by the general public. It does not contain warnings or cautions to advise non-technical individuals of potential dangers in attempting to service a product. Products powered by electricity should be serviced or repaired only by experienced professional technicians. Any attempt to service or repair the product or products dealt with in this service information by anyone else could result in serious injury or death.









TABLE OF CONTENTS

| | PAGE |
|--|----------|
| 1 REPLACEMENT PARTS LIST ----- | 2 |
| 1.1. REFERENCE CHART----- | 2 |
| 1.2. ORIGINAL AND NEW PARTS COMPARISON LISTS----- | 2 |

1 REPLACEMENT PARTS LIST

1.1. REFERENCE CHART

| Reason for Change | |
|---|--|
| *The following items (1-8) indicate the reason for change. See the "Notes" column for each part in ORIGINAL AND NEW PARTS COMPARISON LISTS . | |
| 1. Improve performance | Remarks: *j : To meet the standards. |
| 2. Change of material or dimension | |
| 3. To meet approved specification | |
| 4. Standardization | |
| 5. Addition | |
| 6. Deletion | |
| 7. Correction | |
| 8. Other | |

| Interchangeability Code | | |
|---|---|--|
| **The following items (V-Z) indicate the Interchangeability. See the "Notes" column for each part in ORIGINAL AND NEW PARTS COMPARISON LISTS . | | |
| V | Original  Early (before change) New  Late (after change) | Original or new parts may be used in early or late production sets. Use original parts until exhausted, then stock new parts. |
| W | Original  Early (before change) New  Late (after change) | Original parts may be used in early production sets only. New parts may be used in early or late production sets. Use original parts where possible, then stock new parts. |
| X | Original  Early (before change) New  Late (after change) | New parts only may be used in early or late production sets. Stock new parts. |
| Y | Original  Early (before change) New  Late (after change) | Original parts may be used in early production sets only. New parts may be used in late production sets only. Stock both original and new parts. |
| Z | Other | |

Note:

Alphabets in the "Remarks" column in the following lists correspond to the alphabets in the "Remarks" in REFERENCE CHART.

1.2. ORIGINAL AND NEW PARTS COMPARISON LISTS

| Ref. No. | Part No. | | Part Name & Description | Pcs/ Set | Remarks | Notes | Time of Change (Suffix) |
|---|----------------|-----------|-------------------------|-------------|---------|-------|----------------------------|
| | Original (Old) | New | | | | | |
| Cabinet and Electrical Parts (Handset) | | | | | | | |
| 120 | PNGT5515Y | PNGT7240Y | NAME PLATE | 1 | *j | 4 Y | --- |