

Service Manual

Telephone Equipment

Model No. **KX-TG6671B**
KX-TG6672B
KX-TGA660B

Caller ID Compatible

DECT
6.0

Digital Corded/Cordless Answering System

B: Black Version
(for U.S.A.)



KX-TGA660B
(Portable)



KX-TG6671B
(Base Unit)

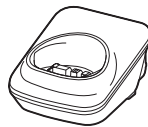

(Charger Unit)

Configuration for each model

Model No	Base Unit	Portable	Charger Unit	Expandable
KX-TG6671	1 (TG6671)	1 (TGA660)	1	Up to 6
KX-TG6672	1 (TG6671)	2 (TGA660)	2	Up to 6
KX-TGA660*		1 (TGA660)	1	

*KX-TGA660 is also an optional accessory, which contains a portable and a charger.

Information for optional accessories

You can expand your phone system by registering optional portables (KX-TGA410 / KX-TGA659) to a single base unit. Optional portables and the supplied portable are different model so that some functions may not be available. Refer to each Operating Instruction for details.

 **WARNING**

This service information is designed for experienced repair technicians only and is not designed for use by the general public. It does not contain warnings or cautions to advise non-technical individuals of potential dangers in attempting to service a product. Products powered by electricity should be serviced or repaired only by experienced professional technicians. Any attempt to service or repair the product or products dealt with in this service information by anyone else could result in serious injury or death.

IMPORTANT SAFETY NOTICE

There are special components used in this equipment which are important for safety. These parts are marked by  in the Schematic Diagrams, Circuit Board Diagrams, Exploded Views and Replacement Parts List. It is essential that these critical parts should be replaced with manufacturer's specified parts to prevent shock, fire or other hazards. Do not modify the original design without permission of manufacturer.

IMPORTANT INFORMATION ABOUT LEAD FREE, (PbF), SOLDERING

If lead free solder was used in the manufacture of this product, the printed circuit boards will be marked PbF. Standard leaded, (Pb), solder can be used as usual on boards without the PbF mark. When this mark does appear, please read and follow the special instructions described in this manual on the use of PbF and how it might be permissible to use Pb solder during service and repair work.

- When you note the serial number, write down all 11 digits. The serial number may be found on the bottom of the unit.
- The illustrations in this Service Manual may vary slightly from the actual product.

TABLE OF CONTENTS

	PAGE		PAGE
1 Safety Precautions -----	4	15.4. Circuit Board (Base Unit_LED)-----	86
1.1. For Service Technicians-----	4	15.5. Circuit Board (Portable_Main)-----	87
2 Warning -----	4	15.6. Circuit Board (Portable_LED)-----	89
2.1. Battery Caution-----	4	15.7. Circuit Board (Charger Unit)-----	90
2.2. About Lead Free Solder (PbF: Pb free)-----	4	16 Exploded View and Replacement Parts List -----	91
2.3. Discarding of P. C. Board-----	5	16.1. Cabinet and Electrical Parts (Base Unit)-----	91
3 Specifications -----	6	16.2. Cabinet and Electrical Parts (Portable)-----	92
4 Technical Descriptions -----	7	16.3. Cabinet and Electrical Parts (Charger Unit)-----	93
4.1. US-DECT Description-----	7	16.4. Accessories and Packing Materials-----	94
4.2. Block Diagram (Base Unit_Main)-----	9	16.5. Replacement Parts List-----	97
4.3. Block Diagram (Base Unit_RF Part)-----	10		
4.4. Circuit Operation (Base Unit)-----	11		
4.5. Block Diagram (Portable)-----	17		
4.6. Block Diagram (Portable_RF Part)-----	18		
4.7. Circuit Operation (Portable)-----	19		
4.8. Circuit Operation (Charger Unit)-----	21		
4.9. Signal Route-----	22		
5 Location of Controls and Components -----	24		
6 Installation Instructions -----	24		
7 Operating Instructions -----	24		
8 Test Mode -----	25		
8.1. Engineering Mode-----	25		
9 Service Mode -----	29		
9.1. How to Clear User Setting (Portable Only)-----	29		
10 Troubleshooting Guide -----	30		
10.1. Troubleshooting Flowchart-----	30		
11 Disassembly and Assembly Instructions -----	44		
11.1. Disassembly Instructions-----	44		
11.2. Assembly Instructions-----	49		
11.3. How to Replace the Portable LCD-----	51		
12 Measurements and Adjustments -----	52		
12.1. Equipment Required-----	52		
12.2. The Setting Method of JIG-----	52		
12.3. Adjustment Standard (Base Unit)-----	56		
12.4. Adjustment Standard (Charger Unit)-----	57		
12.5. Adjustment Standard (Portable)-----	58		
12.6. Things to Do after Replacing IC or X'tal-----	59		
12.7. Frequency Table-----	61		
13 Miscellaneous -----	62		
13.1. How to Replace the LLP (Leadless Leadframe Package) IC-----	62		
13.2. How to Replace the Flat Package IC-----	64		
13.3. How to Replace the Shield Case-----	66		
13.4. Terminal Guide of the ICs, Transistors and Diodes-----	68		
14 Schematic Diagram -----	69		
14.1. For Schematic Diagram-----	69		
14.2. Schematic Diagram (Base Unit_Main)-----	70		
14.3. Schematic Diagram (Base Unit_Operation)-----	72		
14.4. Schematic Diagram (Base Unit_LCD)-----	73		
14.5. Schematic Diagram (Base Unit_LED)-----	74		
14.6. Schematic Diagram (Portable_Main)-----	76		
14.7. Schematic Diagram (Portable_LED)-----	78		
14.8. Schematic Diagram (Charger Unit)-----	79		
15 Printed Circuit Board -----	81		
15.1. Circuit Board (Base Unit_Main)-----	81		
15.2. Circuit Board (Base Unit_Operation)-----	83		
15.3. Circuit Board (Base Unit_LCD)-----	85		

1 Safety Precautions

1.1. For Service Technicians

• **Repair service shall be provided in accordance with repair technology information such as service manual so as to prevent fires, injury or electric shock, which can be caused by improper repair work.**

1. When repair services are provided, neither the products nor their parts or members shall be remodeled.
2. If a lead wire assembly is supplied as a repair part, the lead wire assembly shall be replaced.
3. FASTON terminals shall be plugged straight in and unplugged straight out.

• **ICs and LSIs are vulnerable to static electricity.**

When repairing, the following precautions will help prevent recurring malfunctions.

1. Cover plastic parts boxes with aluminum foil.
2. Ground the soldering irons.
3. Use a conductive mat on worktable.
4. Do not grasp IC or LSI pins with bare fingers.

2 Warning

2.1. Battery Caution

Risk of explosion if battery is replaced by an incorrect type. Dispose of used batteries according to the instructions.

Attention:



A nickel metal hydride battery that is recyclable powers the product you have purchased.

Please call 1-800-8-BATTERY (1-800-822-8837) for information on how to recycle this battery.

2.2. About Lead Free Solder (PbF: Pb free)

Note:

In the information below, Pb, the symbol for lead in the periodic table of elements, will refer to standard solder or solder that contains lead.

We will use PbF solder when discussing the lead free solder used in our manufacturing process which is made from Tin (Sn), Silver (Ag), and Copper (Cu).

This model, and others like it, manufactured using lead free solder will have PbF stamped on the PCB. For service and repair work we suggest using the same type of solder.

Caution

- PbF solder has a melting point that is 50 °F ~ 70 °F (30 °C ~ 40 °C) higher than Pb solder. Please use a soldering iron with temperature control and adjust it to 700 °F ± 20 °F (370 °C ± 10 °C).
- Exercise care while using higher temperature soldering irons.:
Do not heat the PCB for too long time in order to prevent solder splash or damage to the PCB.
- PbF solder will tend to splash if it is heated much higher than its melting point, approximately 1100 °F (600 °C).
- When applying PbF solder to double layered boards, please check the component side for excess which may flow onto the opposite side (See the figure below).

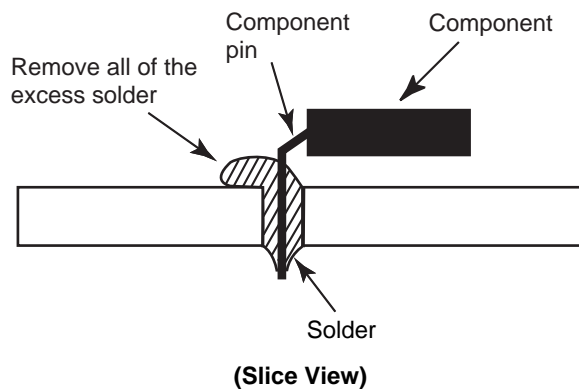

2.2.1. Suggested PbF Solder

There are several types of PbF solder available commercially. While this product is manufactured using Tin, Silver, and Copper (Sn+Ag+Cu), you can also use Tin and Copper (Sn+Cu), or Tin, Zinc, and Bismuth (Sn+Zn+Bi). Please check the manufacturer's specific instructions for the melting points of their products and any precautions for using their product with other materials.

The following lead free (PbF) solder wire sizes are recommended for service of this product: 0.3 mm, 0.6 mm and 1.0 mm.

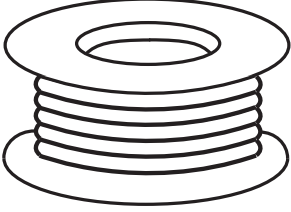
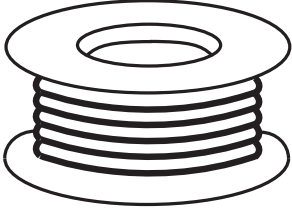
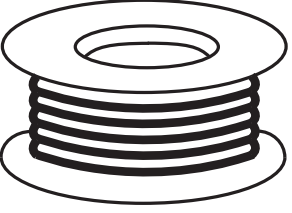
0.3 mm X 100 g	0.6 mm X 100 g	1.0 mm X 100 g
		

2.3. Discarding of P. C. Board

When discarding P. C. Board, delete all personal information such as telephone directory and caller list or scrap P. C. Board.

3 Specifications

■ **Standard:**

DECT 6.0 (Digital Enhanced Cordless Telecommunications 6.0)

■ **Number of channels:**

60 Duplex Channels

■ **Frequency range:**

1.92 GHz to 1.93 GHz

■ **Duplex procedure:**

TDMA (Time Division Multiple Access)

■ **Channel spacing:**

1,728 kHz

■ **Bit rate:**

1,152 kbit/s

■ **Modulation:**

GFSK (Gaussian Frequency Shift Keying)

■ **RF transmission power:**

115 mW (max.)

■ **Voice coding:**

ADPCM 32 kbit/s

	Base Unit	Portable	Charger
Power source	AC Adaptor (PNLV226Z, 120 V AC, 60 Hz)	Rechargeable Ni-MH battery AAA (R03) size (1.2 V 550 mAh)	AC Adaptor (PNLV226Z, 120 V AC, 60 Hz)
Receiving Method	Super Heterodyne	Super Heterodyne	—
Oscillation Method	PLL synthesizer	PLL synthesizer	—
Detecting Method	Quadrature Discriminator	Quadrature Discriminator	—
Tolerance of OSC Frequency	13.824 MHz ±100 Hz	13.824 MHz ±100 Hz	—
Modulation Method	Frequency Modulation	Frequency Modulation	—
ID Code	40 bit	40 bit	—
Ringer Equivalence No. (REN)	0.1B	—	—
Dialing Mode	Tone (DTMF)/Pulse	Tone (DTMF)/Pulse	—
Redial	Up to 48 digits	Up to 48 digits	—
Speed Dialer	Up to 24 digits (Phonebook)	Up to 24 digits (Phonebook)	—
Power Consumption	Standby: Approx. 0.9 W Maximum: Approx. 1.5 W	11 days at Standby, 13 hours at Talk	Standby: Approx. 0.1 W, Maximum: Approx. 2.0 W
Operating Conditions	0 °C - 40 °C (32 °F - 104 °F) 20 % - 80 % relative air humidity (dry)	0 °C - 40 °C (32 °F - 104 °F) 20 % - 80 % relative air humidity (dry)	0 °C - 40 °C (32 °F - 104 °F) 20 % - 80 % relative air humidity (dry)
Dimensions (H x W x D)	Approx. 185 mm x 223 mm x 132 mm	Approx. 173 mm x 48 mm x 32 mm	Approx. 44 mm x 73 mm x 79 mm
Mass (Weight)	Approx. 780 g	Approx. 140 g	Approx. 50 g

Note:

- Design and specifications are subject to change without notice.

Note for Service:

- **Operation range:** Up to 300 m outdoors, Up to 50 m indoors, depending on the condition.
- **Analog telephone connection:** Telephone Line
- **Optional headset:** KX-TCA60, KX-TCA93, KX-TCA94, KX-TCA400, KX-TCA430
- **Optional Range extender:** KX-TGA405

4.1.3. Signal Flowchart in the Radio Parts

Reception

Base unit:

A voice signal from TEL line is encoded to digital data and converted into a 1.9GHz modulated radio signal by BBIC(IC501). The RF signal, after which is amplified in BBIC, is fed to selected antenna.

Portable:

As for a portable RF, RF signal is received in one antenna.

BBIC down-converts to 864 kHz IF signal from RX signal and demodulates it to digital data "RXDATA".

BBIC (IC1) converts RXDATA into a voice signal and outputs it to speaker.

Transmission

Portable:

A voice signal from microphone is encoded to digital data and converted into a 1.9GHz modulated radio signal by BBIC(IC1). The RF signal, after which is amplified in BBIC, is fed to an antenna.

Base unit:

As for a base unit RF, RF signal is received in two antennas.

BBIC (IC501) compares RF signal levels and selects the antenna to be used. Then BBIC down-converts to 864 kHz IF signal from RX signal in the selected antenna, and demodulates it to digital data "RXDATA".

BBIC (IC501) converts RXDATA into a voice signal and outputs it to TEL line.

4.3. Block Diagram (Base Unit_RF Part)

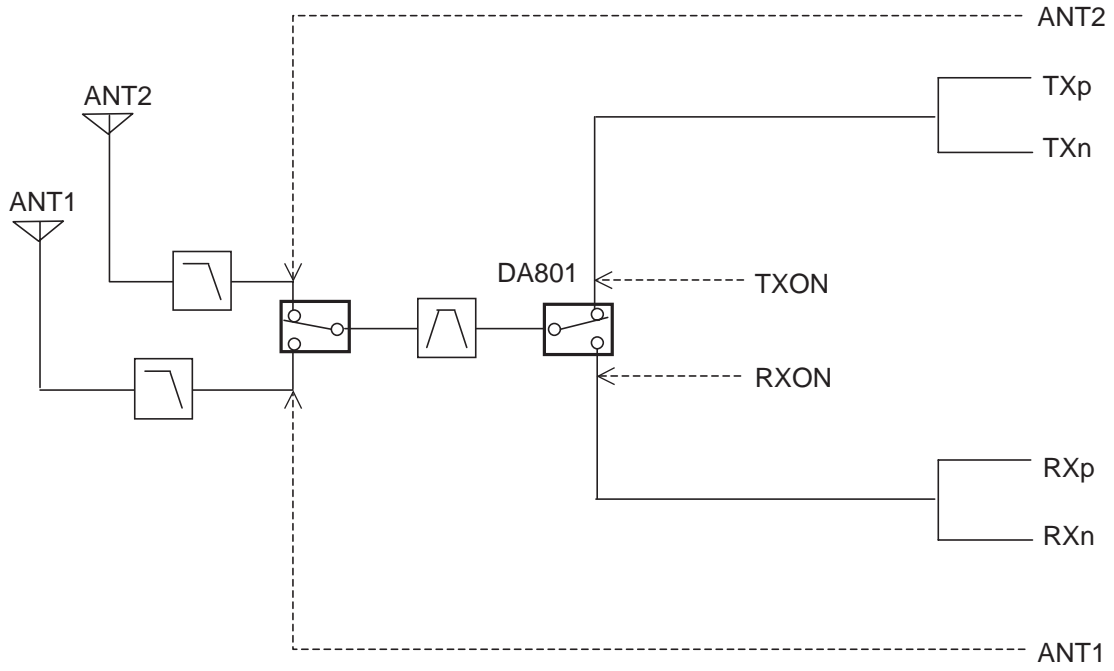

KX-TG6671/6672 BLOCK DIAGRAM (Base Unit_RF Part)

4.4. Circuit Operation (Base Unit)

General Description:

(BBIC, Flash Memory, EEPROM) is a digital speech/signal processing system that implements all the functions of speech compression, record and playback, and memory management required in a digital telephone answering machine.

The BBIC system is fully controlled by a host processor. The host processor provides activation and control of all that functions as follows.

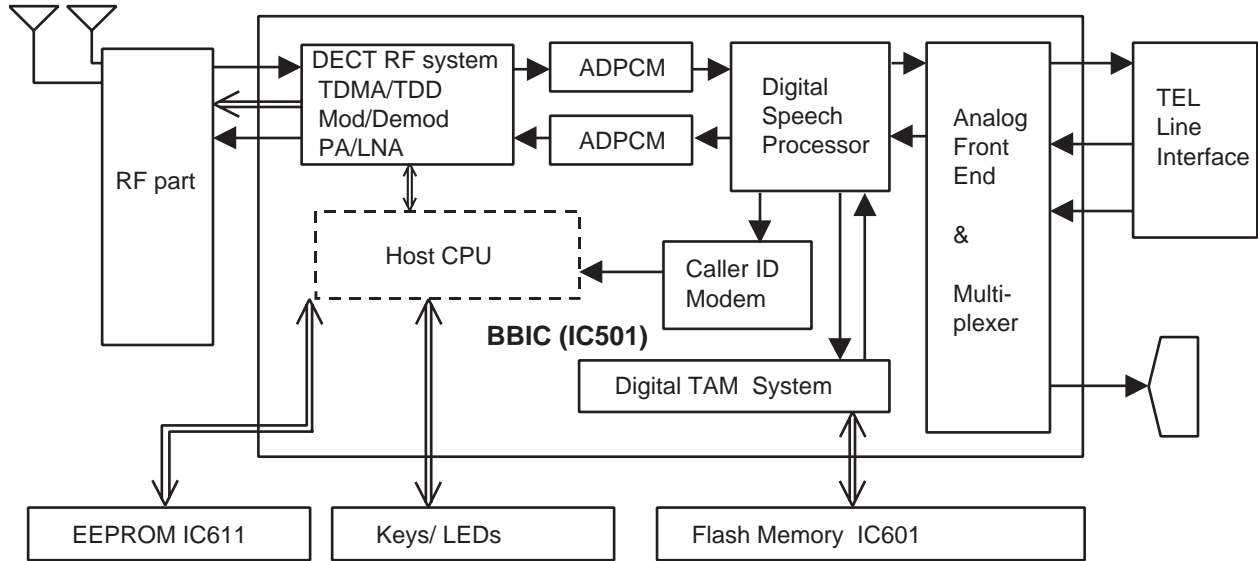

4.4.1. BBIC (Base Band IC: IC501)

- **Voice Message Recording/Play back**

The BBIC system uses a proprietary speech compression technique to record and store voice message in Flash Memory.

An error correction algorithm is used to enable playback of these messages from the Flash Memory.

- **DTMF Generator**

When the DTMF data from the portable is received, the DTMF signal is output.

- **Synthesized Voice (Pre-recorded message)**

The BBIC implements synthesized Voice, utilizing the built in speech detector and a Flash Memory, which stored the vocabulary.

- **Caller ID demodulation**

The BBIC implements monitor and demodulate the FSK/DTMF signals that provide CID information from the Central Office.

- **Digital Switching**

The voice signal from telephone line is transmitted to the portable or the voice signal from the portable is transmitted to the Telephone line, etc. They are determined by the signal path route operation of voice signal.

- **Block Interface Circuit**

RF part, LED, Key scan, Speaker, Telephone line.

4.4.2. Flash Memory (IC601)

Following information data is stored.

- **Voice signal**

ex: Pre-recorded Greeting message, Incoming message

4.4.3. EEPROM (IC611)

Following information data is stored.

- **Settings**

ex: message numbers, ID code, Flash Time, Tone/Pulse

4.4.4. Power Supply Circuit/Reset Circuit

The power supply voltage from AC adaptor is converted to VBAT (3.0V) in IC302. And +3.0V for peripherals and analog part is insulated from VBAT by Doubler of BBIC.

Circuit Operation:

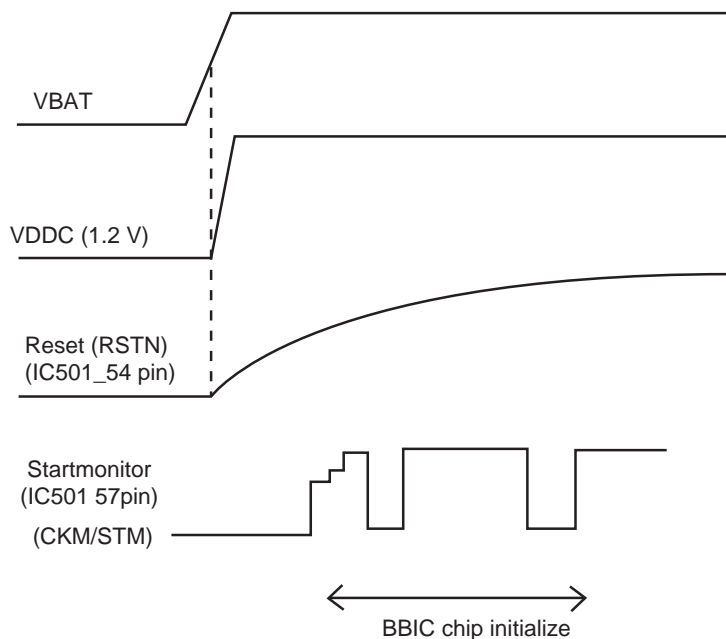
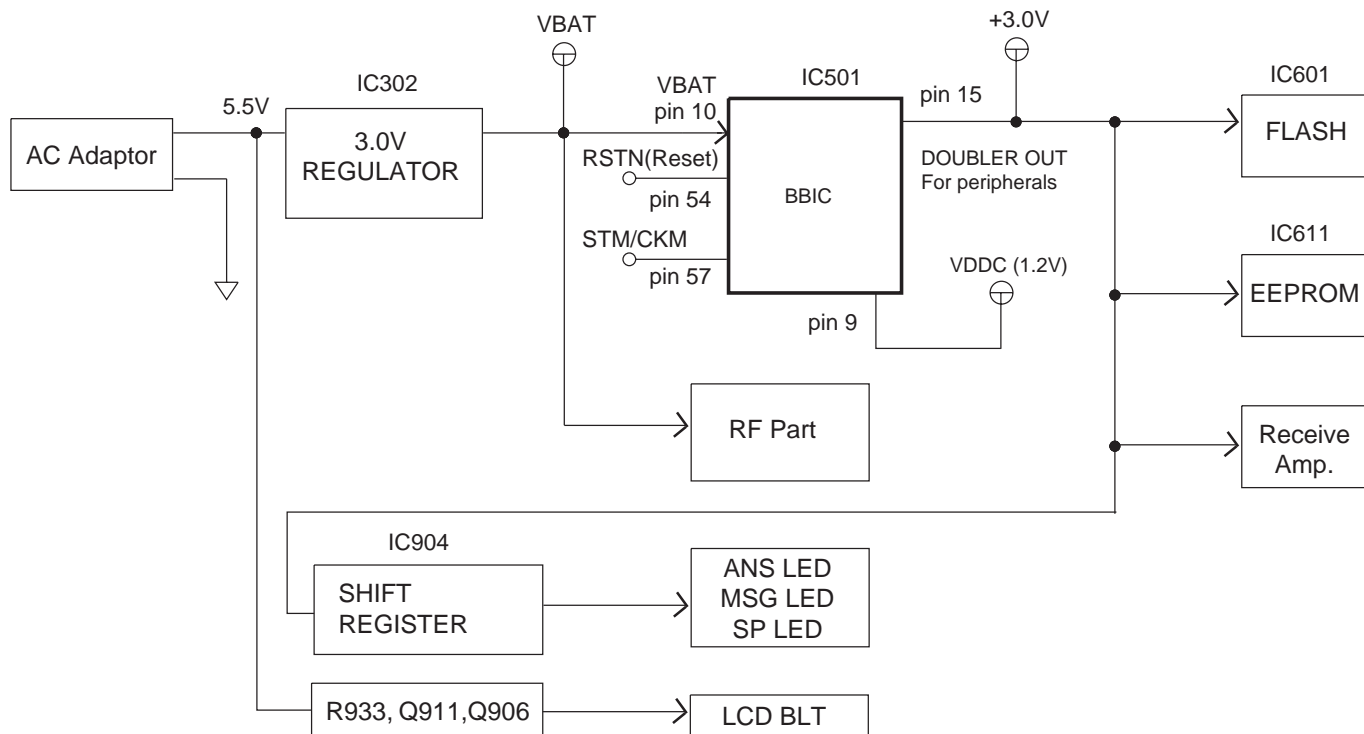

4.4.5. Telephone Line Interface

Telephone Line Interface Circuit:

Function

- Bell signal detection
- ON/OFF hook and pulse dial circuit
- Side tone circuit

Bell signal detection and OFF HOOK circuit:

In the idle mode, Q141 is open to cut the DC loop current and decrease the ring load. When ring voltage appears at the Tip (T) and Ring (R) leads (When the telephone rings), the AC ring voltage is transferred as follows:

T → R111 → C111 → Q111 → BBIC pin 59

When the CPU (BBIC) detects a ring signal, Q141 turns on, thus providing an off-hook condition (active DC current flow through the circuit). Following signal flow is the DC current flow.

T → D101 → Q902 → Q161 → R163 → R167 → D908 → D909 → Q913 → D101 → P101 → R

ON HOOK Circuit:

Q902 is open, Q902 is connected as to cut the DC loop current and to cut the voice signal. The unit is consequently in an on-hook condition.

Pulse Dial Circuit:

Pin 6 of BBIC turns Q902 ON/OFF to make the pulse dialing.

Side Tone Circuit:

Basically this circuit prevents the TX signal from feeding back to RX signal. As for this unit, TX signal feed back from Q161 is canceled by the canceller circuit of BBIC.

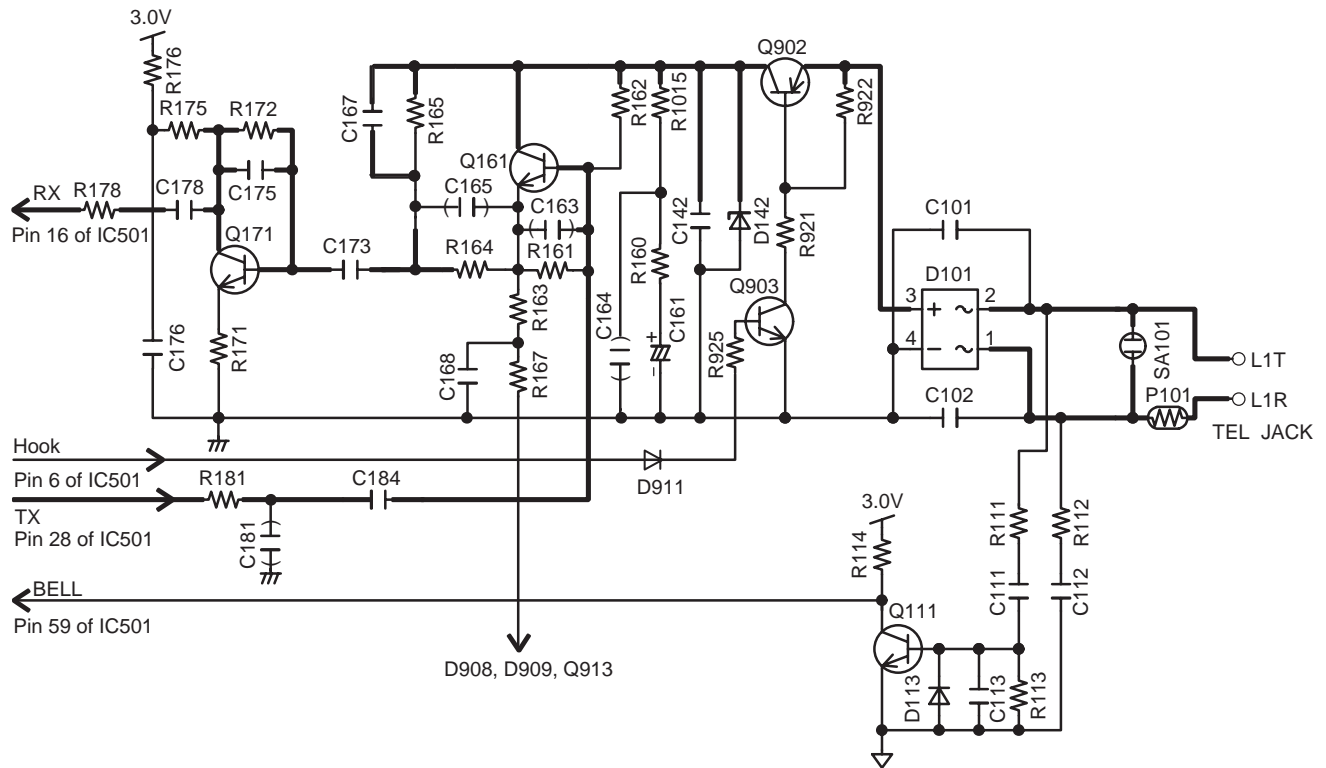

Power Failure Ringing

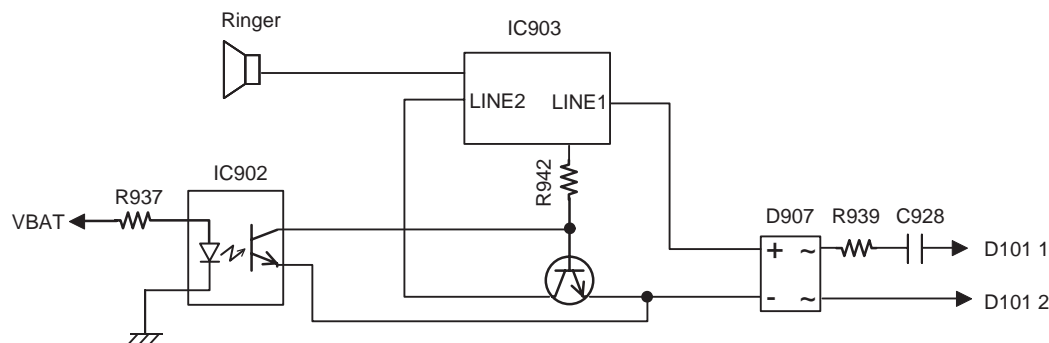

4.4.6. Parallel Connection Detect Circuit/Auto Disconnect Circuit

Function:

In order to disable call waiting and stutter tone functions when using telephones connected in parallel, it is necessary to have a circuit that judges whether a telephone connected in parallel is in use or not. This circuit determines whether the telephone connected in parallel is on hook or off hook by detecting changes in the T/R voltage.

Circuit Operation:

Parallel connection detection when on hook:

When on hook, the voltage is monitored at pin 17 of IC501. There is no parallel connection if the voltage is 0.54 V or higher, while a parallel connection is deemed to exist if the voltage is lower.

Parallel connection detection when off hook:

When off hook, the voltage is monitored at pin 18 of IC501; the presence/absence of a parallel connection is determined by detecting the voltage changes.

If the Auto disconnect function is ON and statuses are Hold, receiving ICM, OGM transmitting, BBIC disconnects the line after detecting parallel connection is off hook.

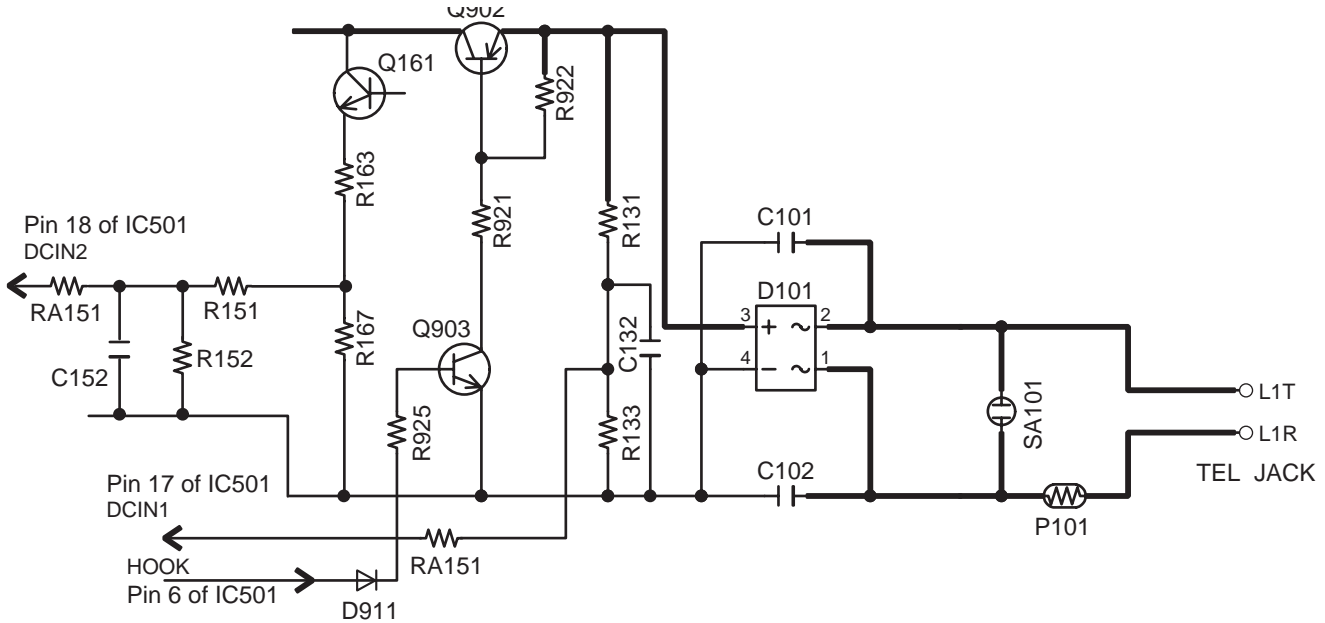

4.4.7. Calling Line Identification (Caller ID)/Call Waiting Caller ID

Function:

Caller ID

The caller ID is a chargeable ID which the user of a telephone circuit obtains by entering a contract with the telephone company to utilize a caller ID service. For this reason, the operation of this circuit assumes that a caller ID service contract has been entered for the circuit being used. The data for the caller ID from the telephone exchange is sent during the interval between the first and second rings of the bell signal. The data from the telephone exchange is a modem signal which is modulated in an FSK (Frequency Shift Keying) * format. Data "1" is a 1200 Hz sine wave, and data "0" is a 2200 Hz sine wave. There are two types of the message format which can be received: i.e. the single message format and plural message format. The plural message format allows to transmit the name and data code information in addition to the time and telephone number data.

*: Also the telephone exchange service provides other formats.

- Single message format

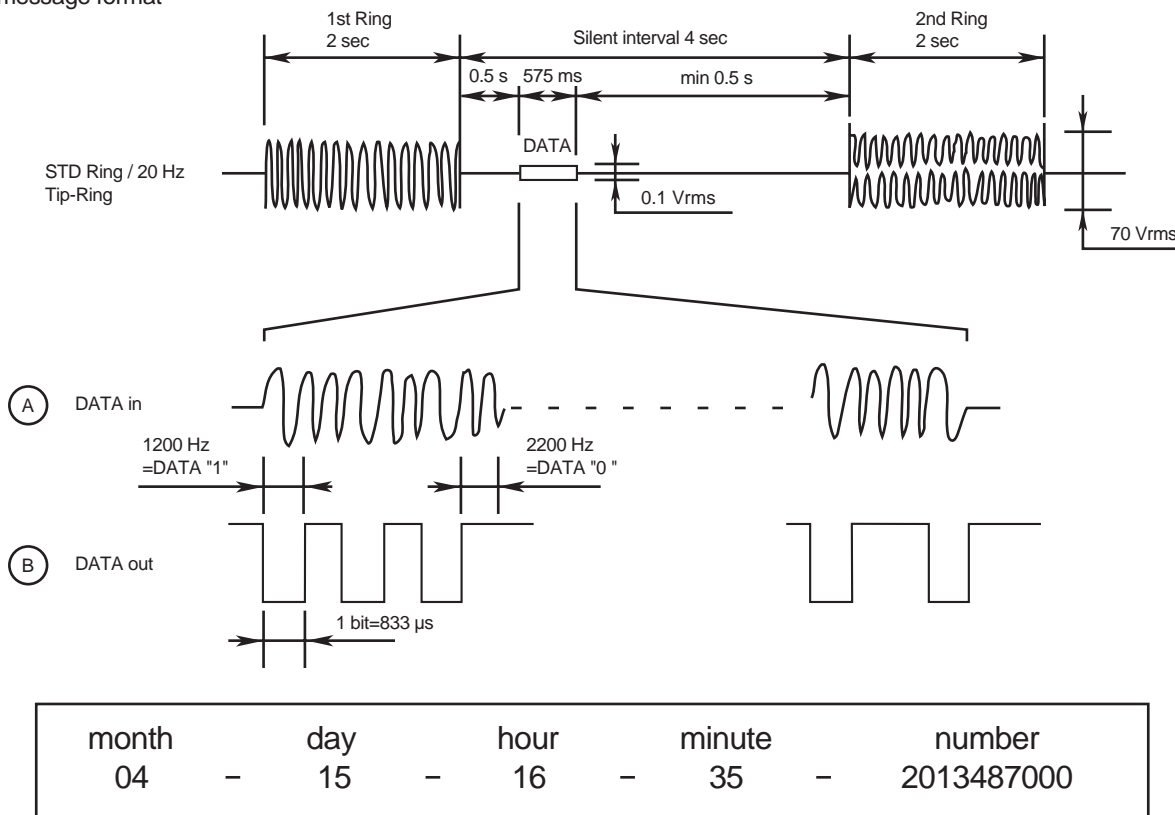

- Plural message format

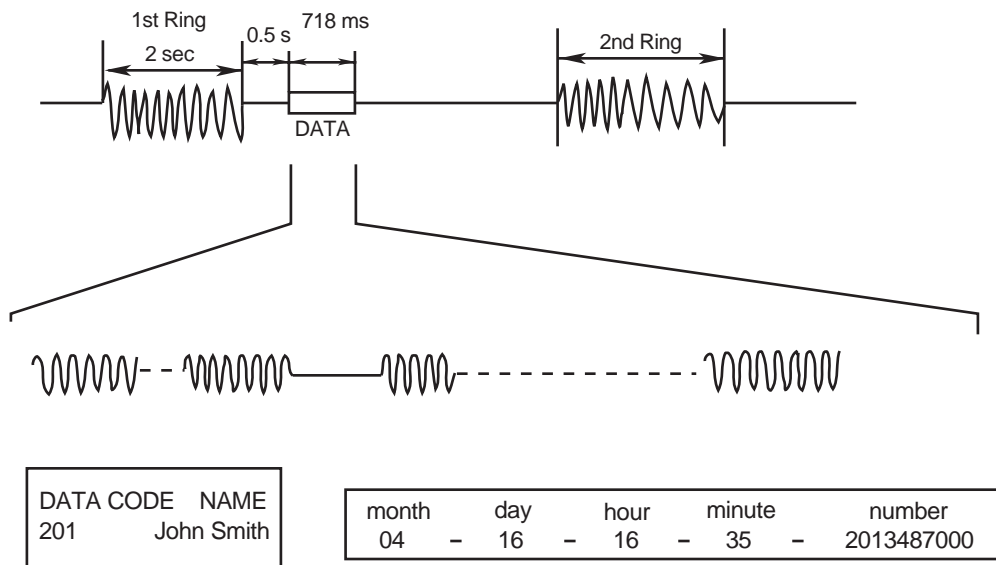

Call Waiting Caller ID

Calling Identity Delivery on Call Waiting (CIDCW) is a CLASS service that allows a customer, while off-hook on an existing call, to receive information about a calling party on a waited call. The transmission of the calling information takes place almost immediately after the customer is alerted to the new call so he/she can use this information to decide whether to take the new call.

Function:

The telephone exchange transmits or receives CAS and ACK signals through each voice RX/TX route. Then FSK data and MARK data pass the following route.

Telephone Line → P101 → C121, C122 → R121, R122 → IC501 (25, 24).

If the unit deems that a telephone connected in parallel is in use, ACK is not returned even if CAS is received, and the information for the second and subsequent callers is not displayed on the portable display.

Call Waiting Format

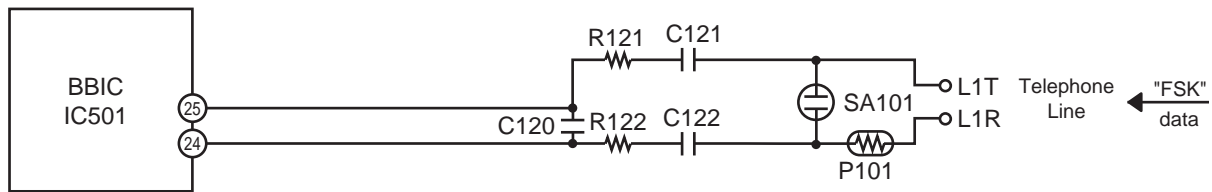
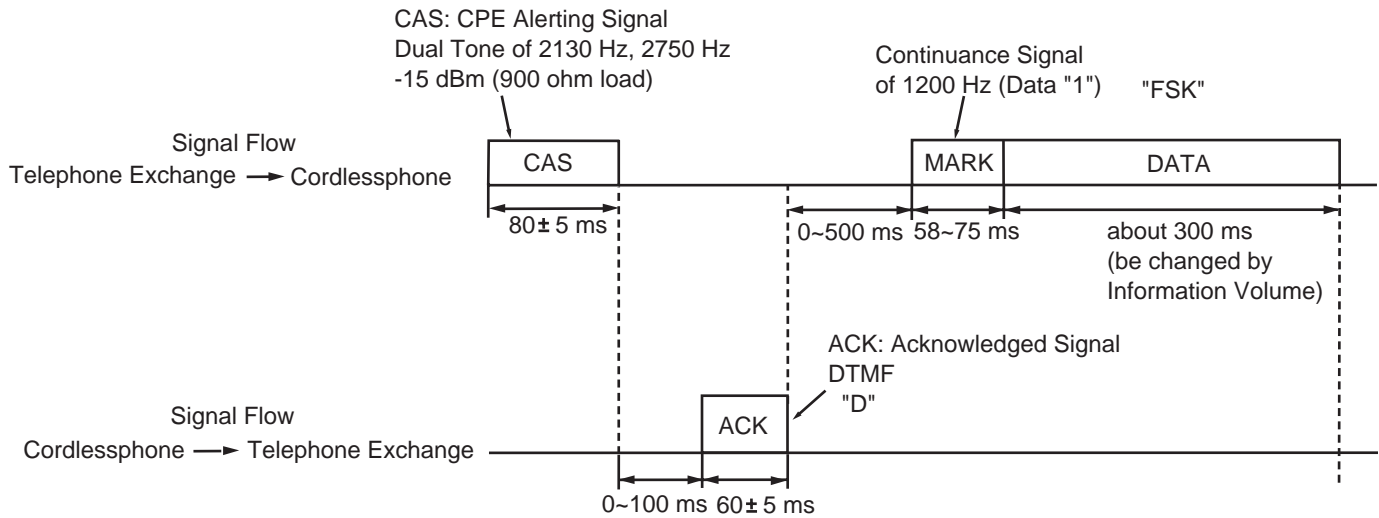

4.5. Block Diagram (Portable)

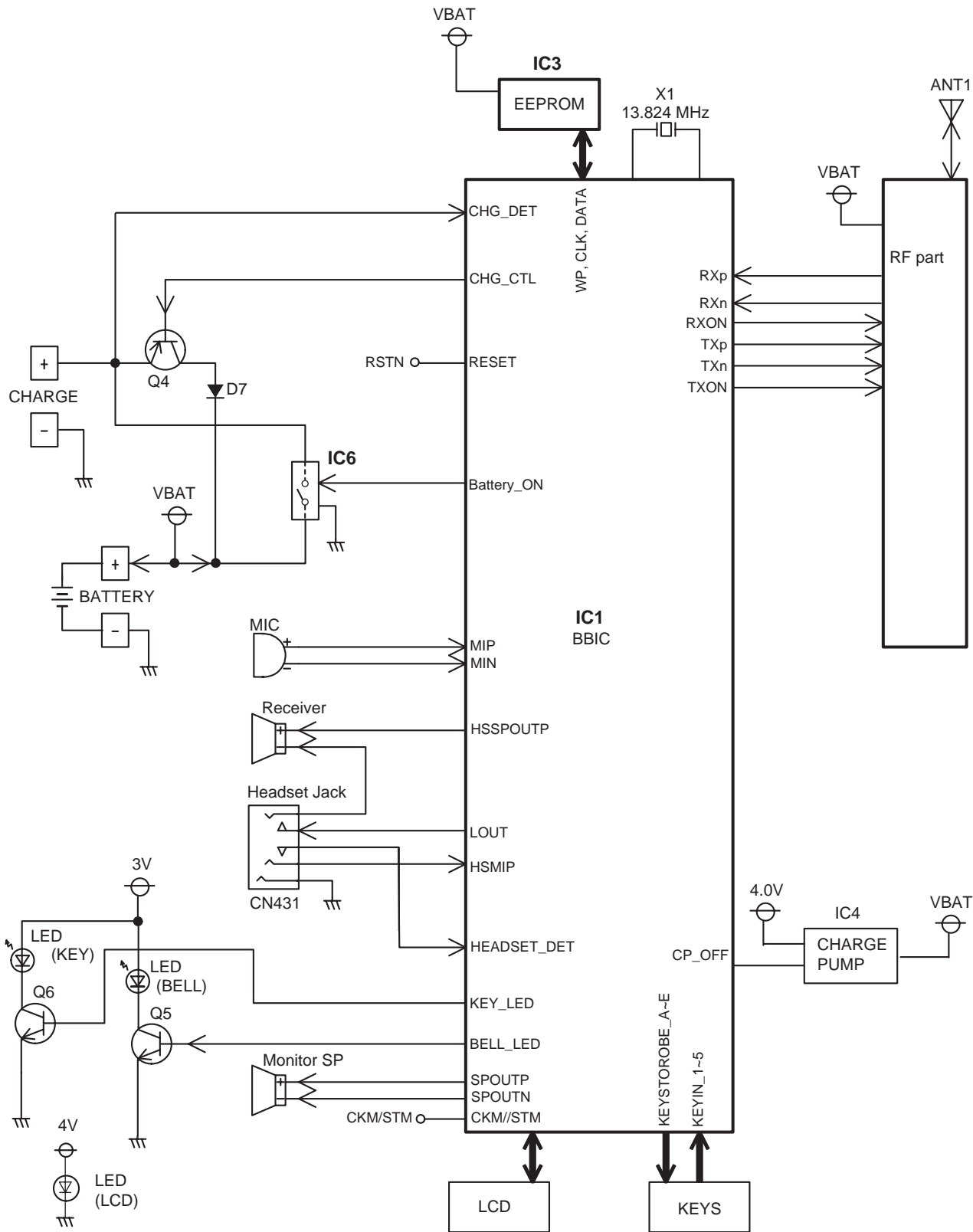

KX-TGA660 BLOCK DIAGRAM (Portable)

4.6. Block Diagram (Portable_RF Part)

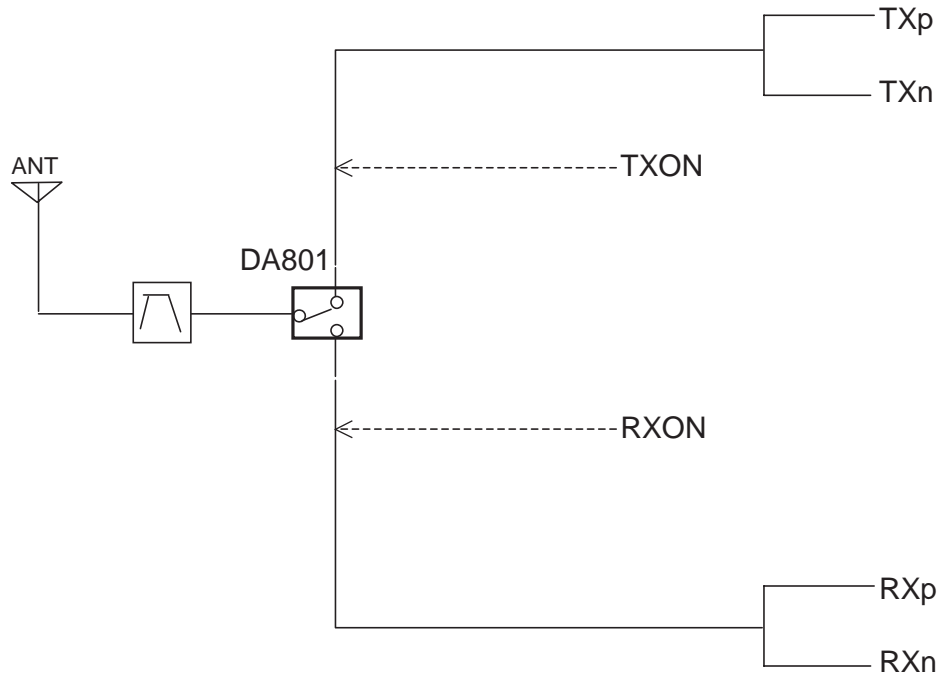

KX-TGA660 BLOCK DIAGRAM (Portable_RF Part)

4.7. Circuit Operation (Portable)

4.7.1. Outline

Portable consists of the following ICs as shown in **Block Diagram (Portable)** (P.17).

- DECT BBIC (**B**ase **B**and IC): IC1
 - All data signals (forming/analyzing ACK or CMD signal)
 - All interfaces (ex: Key, Detector Circuit, Charge, EEPROM, LCD)
- EEPROM: IC3
 - Setting data is stored. (e.g. ID, user setting)

4.7.2. Power Supply Circuit/Reset Circuit

Circuit Operation:

When power on the Portable, the voltage is as follows;
 BATTERY(2.2 V ~ 2.6 V: BATT+) → F1 → BBC1 (IC1) 10 pin
 The Reset signal generates IC1 (54 pin) and 1.8 V.

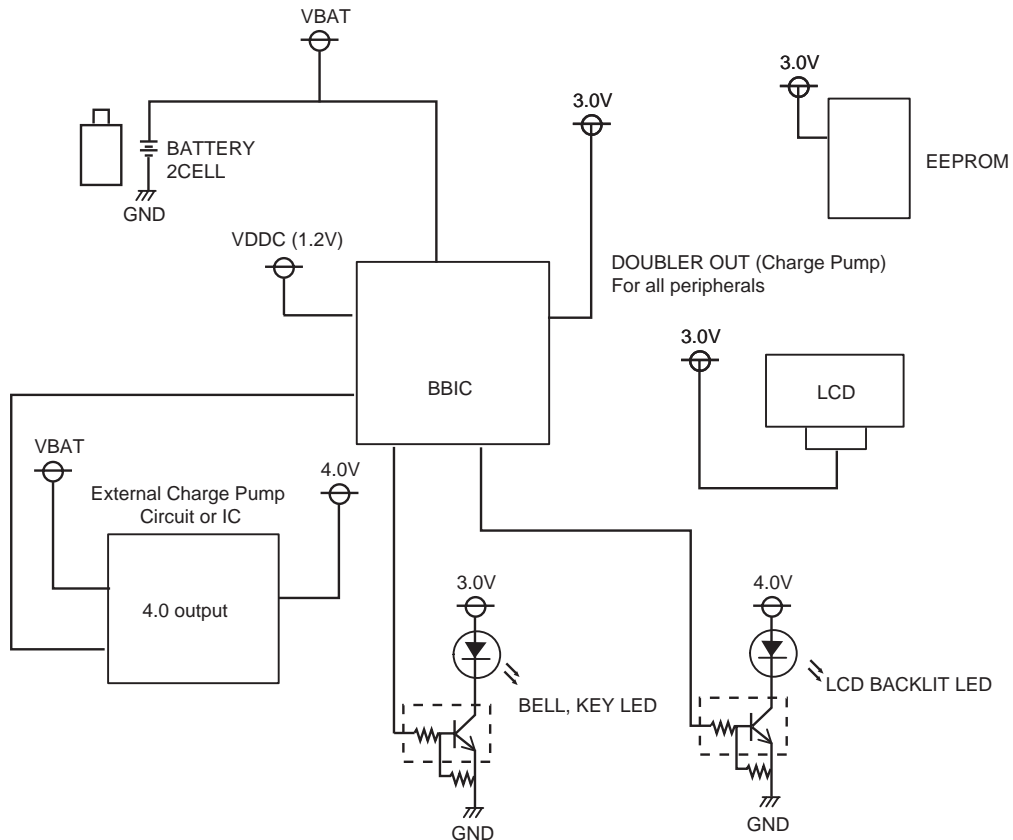
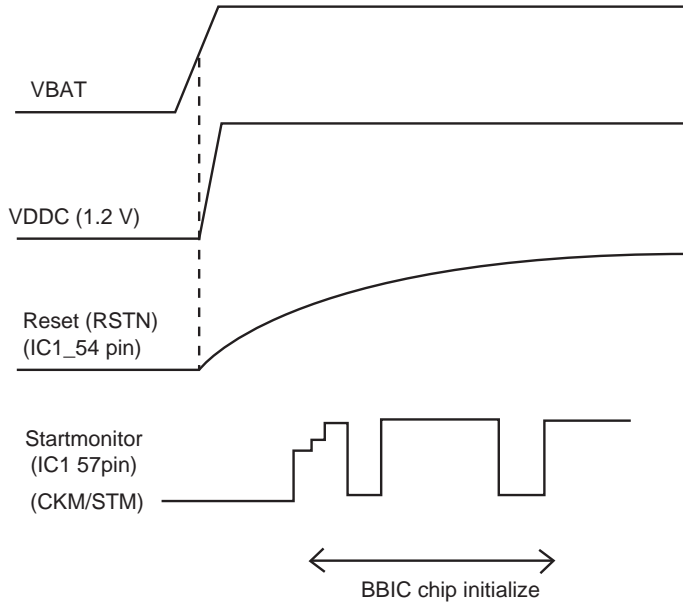

4.7.3. Charge Circuit

Circuit Operation:

When charging the Portable on the Base Unit, the charge current is as follows;

DC+(6.5 V) → F301 → R371 → R372 → CHARGE+(Base) → CHARGE+(Portable) → Q4 → D7 → F1 → BATTERY+... Battery...

BATTERY- → R45 → GND → CHARGE-(Portable) → CHARGE-(Base) → GND → DC-(GND)

In this way, the BBIC on Portable detects the fact that the battery is charged.

The charge current is controlled by switching Q9 of Portable.

Refer to Fig.101 in **Power Supply Circuit/Reset Circuit** (P.12).

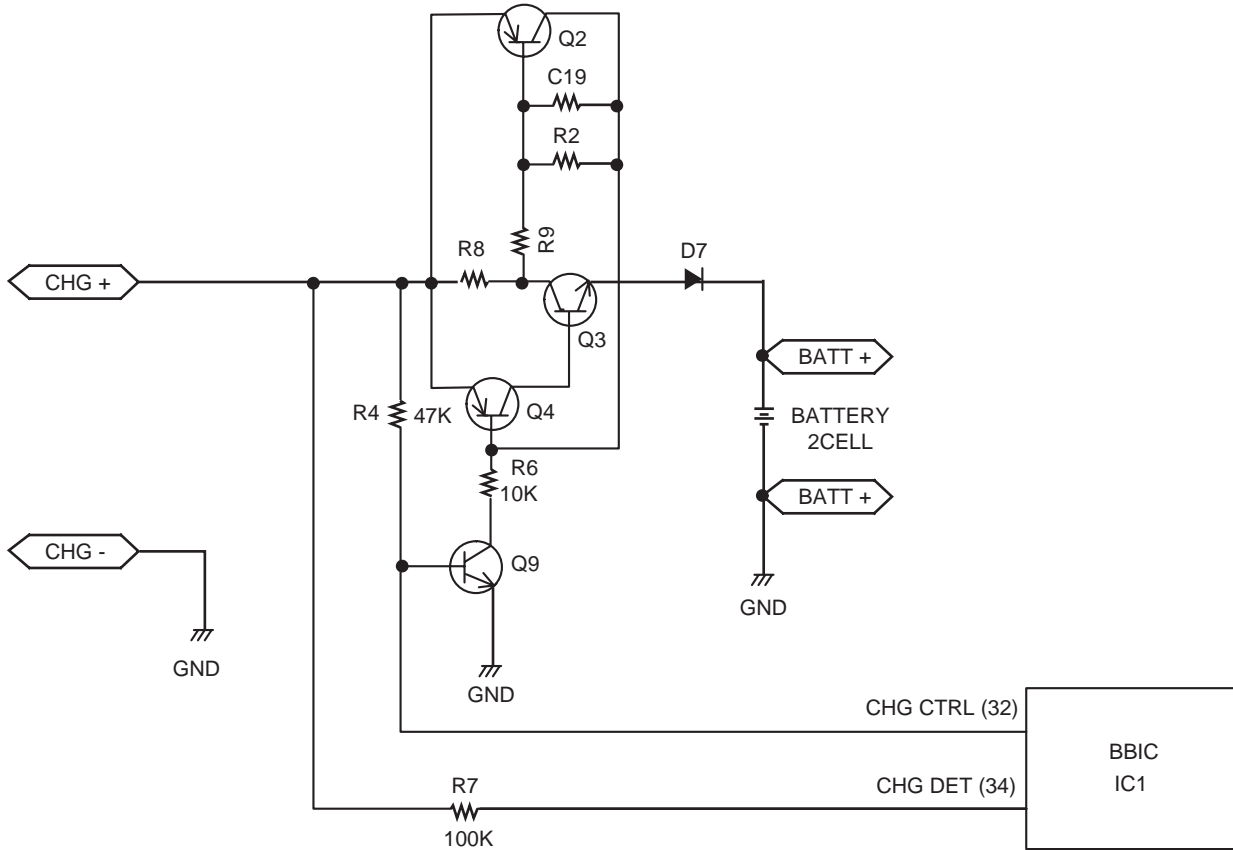

4.7.4. Battery Low/Power Down Detector

Circuit Operation:

"Battery Low" and "Power Down" are detected by BBIC which check the voltage from battery.

The detected voltage is as follows;

- Battery Low
Battery voltage: $V(\text{Batt}) \leq 2.35 \text{ V} \pm 50 \text{ mV}$
The BBIC detects this level and "🔋" starts flashing.
- Power Down
Battery voltage: $V(\text{Batt}) \leq 2.1 \text{ V} \pm 50 \text{ mV}$
The BBIC detects this level and power down.

4.7.5. Speakerphone

The hands-free loudspeaker at SP+ and SP- is used to generate the ring alarm.

4.8. Circuit Operation (Charger Unit)

Charge control is executed at Portable side so that the operation when using charger is also controlled by Portable.
Refer to **Circuit Operation (Portable)** (P.19)

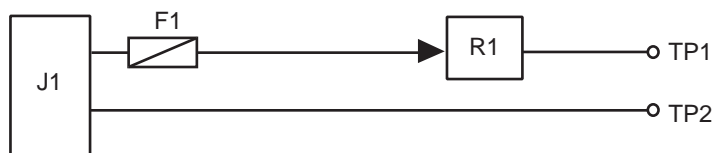

AC Adaptor

The route for this is as follows: DC+pin of J1(+) → F1 → R1 → CHARGE+pad → Portable → CHARGE-pad → DC-pin of J1(-).

4.9. Signal Route

SIGNAL ROUTE	IN	→	ROUTE	→	OUT
PORTABLE TX			PORTABLE MIC - R73/74 - C11/13 - RA4 - IC1(22/23) - <PORTABLE_RF_TX_ROUTE> - ANT. ---		
			---ANT. - <BASE_UNIT_RF_RX_ROUTE> - IC501(46/47 - 28) - C184 - Q161 - Q902 - D101 - [P101] - T/R(TEL LINE)		
PORTABLE RX			T/R(TEL LINE) - [P101] - D101 - Q902 - R165 - C173 - Q171 - C178 - R178 - IC501(16 - 44/45) - <BASE_UNIT_RF_TX_ROUTE> - ANT. ---		
			--- ANT. - <PORTABLE_RF_RX_ROUTE> - IC1(28/27) - C86 - L74 - PORTABLE_JACK(5 - 4) - PORTABLE SPEAKER		
PORTABLE TX			PORTABLE_JACK(2) - R306 - C14 - R22 - IC1(25) - <PORTABLE_RF_TX_ROUTE> - ANT. ---		
			---ANT. - <BASE_UNIT_RF_RX_ROUTE> - IC501(46/47 - 28) - C184 - Q161- Q902 - D101 - [P101] - T/R(TEL LINE)		
PORTABLE RX			T/R(TEL LINE) - [P101] - D101 - Q902 - R165 - C173 - Q171 - C178 - R178 - IC501(16 - 44/45) - <BASE_UNIT_RF_TX_ROUTE> - ANT. ---		
			--- ANT. - <PORTABLE_RF_RX_ROUTE> - IC1(28) - C86 - L74 - HEADSET_JACK(5)		
PORTABLE SP-Phone TX			PORTABLE MIC - R73/74 - C11/13 - RA4 - IC1(22/23) - <PORTABLE_RF_TX_ROUTE> - ANT. ---		
			---ANT. - <BASE_UNIT_RF_RX_ROUTE> - IC501(46/47 - 28) - C184 - Q161 - Q902 - D101 - [P101] -T/R(TEL LINE)		
PORTABLE SP-Phone RX			T/R(TEL LINE) - [P101] - D101 - Q902 - R165 - C173 - Q171 - C178 -R178 - IC501(16-44/45) - <BASE_UNIT_RF_TX_ROUTE> - ANT. ---		
			--- ANT. -<PORTABLE_RF_RX_ROUTE> - IC1(29/31) - Backside SP		
BASE HANDSET TX			MIC - C457/C458 - R945 - IC501(23/22-28) - C184 - Q161 - Q902 - D101 - [P101] - T/R(TEL LINE)		
BASE HANDSET RX			T/R(TEL LINE) - [P101] - D101 - Q902 - Q161 - C173 - Q171 - C178 - R178 - IC501(16-27/GND) - RECEIVER		
BASE SP-Phone TX			MIC - C918/C919 - R946 - IC501 (23/22 - 28) - C184 - Q161 - Q902 - - D101 - [P101] - T/R(TEL LINE)		
BASE SP-Phone RX			T/R(TEL LINE) - [P101] - D101 - Q902 - R165 - C173 - Q171 - C178 - R178 - IC501 (16 - 29/31) - SPEAKER		
INTERCOM PORTABLE TO BASE UNIT			PORTABLE MIC - R73/74 - C11/13 - RA4 - IC1(22/23) - <PORTABLE_RF_TX_ROUTE> - ANT. ---		
			--- ANT. - <BASE_UNIT_RF_RX_ROUTE> - IC501(46/47 - 29/31) - SPEAKER		
INTERCOM BASE UNIT TO PORTABLE			HANDSETMIC/MIC - C457&C458/C918&919 - R945/R946 - IC501(23/22 - 44/45) - <BASE_UNIT_RF_TX_ROUTE> - ANT. ---		
			--- ANT. - <PORTABLE_RF_RX_ROUTE> - IC1(28/27) - C86 - L74 - PORTABLE_JACK(5 - 4) - R11 - PORTABLE SPEAKER		
GREETING RECORDING			PORTABLE MIC - R73/74 - C11/13 - RA4 - IC1(22/23) - <PORTABLE_RF_TX_ROUTE> - ANT. ---		
			---ANT. - <BASE_UNIT_RF_RX_ROUTE> - IC501(46/47- 73/74) - IC601		
GREETING PLAY TO TEL LINE			IC601 - IC501(73/74 - 28) - C184 - Q161 - Q902 - D101 - [P101] - T/R(TEL LINE)		
ICM RECORDING			T/R(TEL LINE) - [P101] - D101 - Q902 - R165 - C173 - Q171 - C178 - R178 - IC501(16 - 73/74) - IC601		
ICM PLAY TO SPEAKER			IC601 - IC501(73/74 - 29/31) - SPEAKER		
DTMF SIGNAL TO TEL LINE			IC501(28) - C184 - Q161 - Q902 - D101 - [P101] - T/R(TEL LINE)		
CALLER ID			T/R(TEL LINE) - [P101] - C121/C122 - R121/R122 - IC501(24/25)		
BELL DETECTION			T/R(TEL LINE) - [P101] - R111/R112 - C111/C112 - Q111 - IC501(59)		

Note:

☐: inside of Portable

RF part signal route

SIGNAL ROUTE	IN	→	ROUTE	→	OUT
PORTABLE RF [TX_ROUTE]	IC1(44/45) - L809 - C812 - DA801 - C895 - ANT				
PORTABLE RF [RX_ROUTE]	ANT - C895 - DA801 - C826 - IC1(46/47)				
BASE UNIT RF [TX_ROUTE]	IC501(44/45) - C812 - L809 - DA801 - C895 - DA802 - C894/C893 - ANT1/ANT2				
BASE UNIT RF [RX_ROUTE]	ANT1/ANT2 - C894/C893 - DA802 - C895 - DA801 - C826 - IC501(46/47)				

Note:

: inside of Portable

5 Location of Controls and Components

Refer to the Operating Instructions.

Note:

You can download and refer to the Operating Instructions (Instruction book) on TSN Server.

6 Installation Instructions

Refer to the Operating Instructions.

Note:

You can download and refer to the Operating Instructions (Instruction book) on TSN Server.

7 Operating Instructions

Refer to the Operating Instructions.

Note:

You can download and refer to the Operating Instructions (Instruction book) on TSN Server.

8 Test Mode

8.1. Engineering Mode

8.1.1. Base Unit

Important:

Make sure the address on LCD is correct when entering new data. Otherwise, you may ruin the unit.

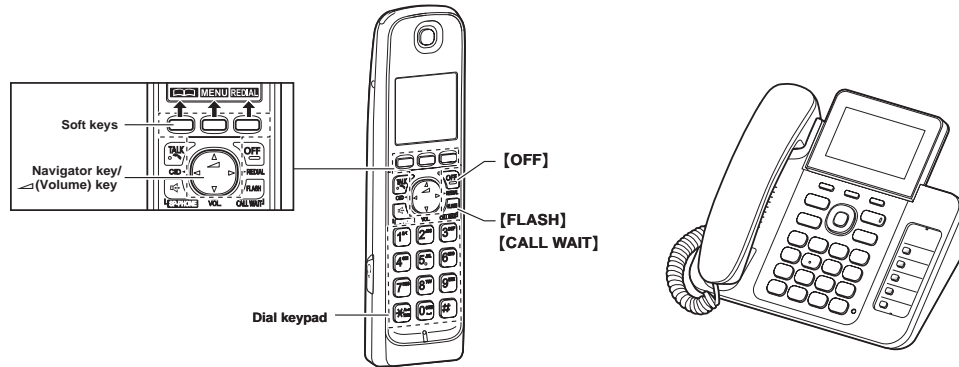

H/S key operation

- 1). Press **MENU** .
- 2). Select "Initial Setting" using **[▲]** or **[▼]** then press **SELECT** or **[▶]**.

 Select "Set tel line" using **[▲]** or **[▼]** then press **SELECT** or **[▶]**.
- 3). Enter "7", "2", "6", "2", "7", "6", "6", "4".
Note: 7262 7664 = PANA SONI
 (see letters printed on dial keys)
- 4). Select "Write EEP" using **[▲]** or **[▼]** then press **SELECT** or **[▶]**.
- 5). Enter "●", "●", "●", "●" (Address). (*1)
- 6). Enter "*" , "*" (New Data). (*1)
- 7). Press **OK** , a long confirmation beep will be heard.
- 8). Press **[OFF]** to return to standby mode.
 After that, turn the base unit power off and then power on.

H/S LCD

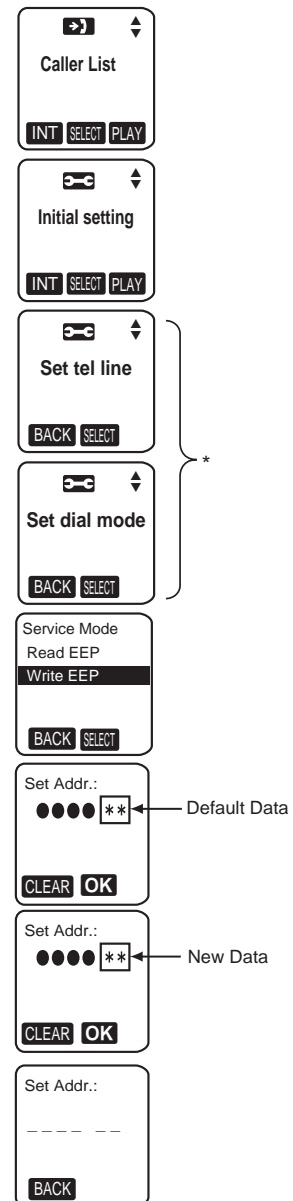

Note: * To enter "Set dial mode", press **SELECT** or **[▶]** at " Set tel line". It is necessary to turn on the power of base unit.

Frequently Used Items (Base Unit)

ex.)

Items	Address	Default Data	New Data		Remarks
Frequency	00 07 / 00 08	00/01	-	-	Use these items in a READ-ONLY mode to confirm the contents. Careless rewriting may cause serious damage to the computer system.
ID	00 02 ~ 00 06	Given value	-	-	

Note:

(*1) When you enter the address or New Data, please refer to the table below.

Desired Number (hex)	Input Keys	Desired Number (hex)	Input Keys
0	0	A	[Flash] + 0
1	1	B	[Flash] + 1
.	.	C	[Flash] + 2
.	.	D	[Flash] + 3
.	.	E	[Flash] + 4
9	9	F	[Flash] + 5

8.1.2. Portable

Important:

Make sure the address on LCD is correct when entering new data. Otherwise, you may ruin the unit.

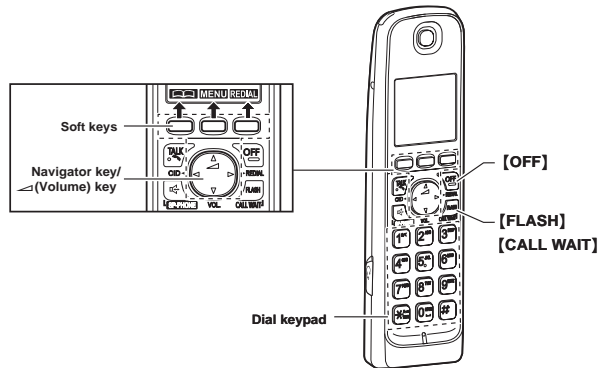

H/S key operation

- 1). Press **MENU** .
- 2). Select "Initial Setting" using **[▲]** or **[▼]** then press **SELECT** or **[▶]**.
- 3). Enter "7", "2", "6", "2", "7", "6", "6", "4".
Note: 7262 7664 = PANA SONI
(see letters printed on dial keys)
- 4). Select "Write EEP" using **[▲]** or **[▼]** then press **SELECT** or **[▶]**.
- 5). Enter "●", "●", "●", "●" (Address). (*1)
- 6). Enter " * ", " * " (New Data). (*1)
- 7). Press **OK** , a long confirmation beep will be heard.
- 8). Press **[OFF]** to return to standby mode.

H/S LCD

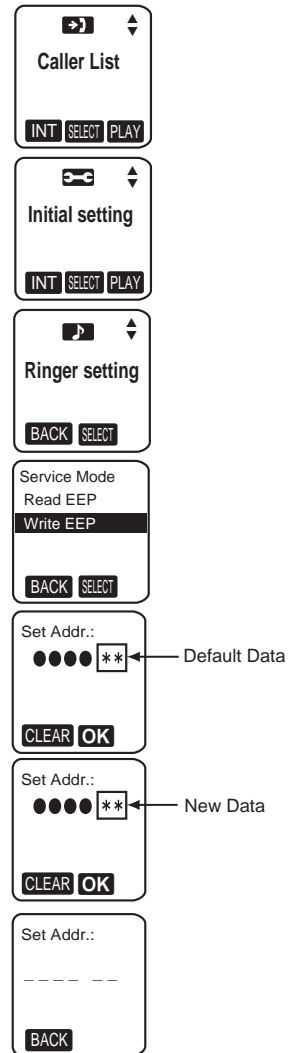

After that, remove and reinsert the batteries. Press the Power button for about 1 second if the power is not turned on.

Frequently Used Items (Portable)

ex.)

Items	Address	Default Data	New Data	Possible Adjusted Value MAX (hex)	Possible Adjusted Value MIN (hex)	Remarks
Battery Low	00 12/00 13	00 / 00	-	-	-	(*2)
Frequency	00 07 / 00 08	00 / 01	-	-	-	
ID	00 02 ~ 00 06	Given value	-	-	-	

Note:

(*1) When you enter the address or New Data, please refer to the table below.

Desired Number (hex.)	Input Keys	Desired Number (hex.)	Input Keys
0	0	A	[Flash] + 0
1	1	B	[Flash] + 1
.	.	C	[Flash] + 2
.	.	D	[Flash] + 3
.	.	E	[Flash] + 4
9	9	F	[Flash] + 5

(*2) Use these items in a READ-ONLY mode to confirm the contents. Careless rewriting may cause serious damage to the Portable.

9 Service Mode

9.1. How to Clear User Setting (Portable Only)

Portable

Press **2**, **5**, **8**, **0** simultaneously until a beep sound is heard. Then single portable is initialized.

(The contents of user setting are reset to factory default)

*Usage time is not cleared.

10 Troubleshooting Guide

10.1. Troubleshooting Flowchart

FLOW CHART

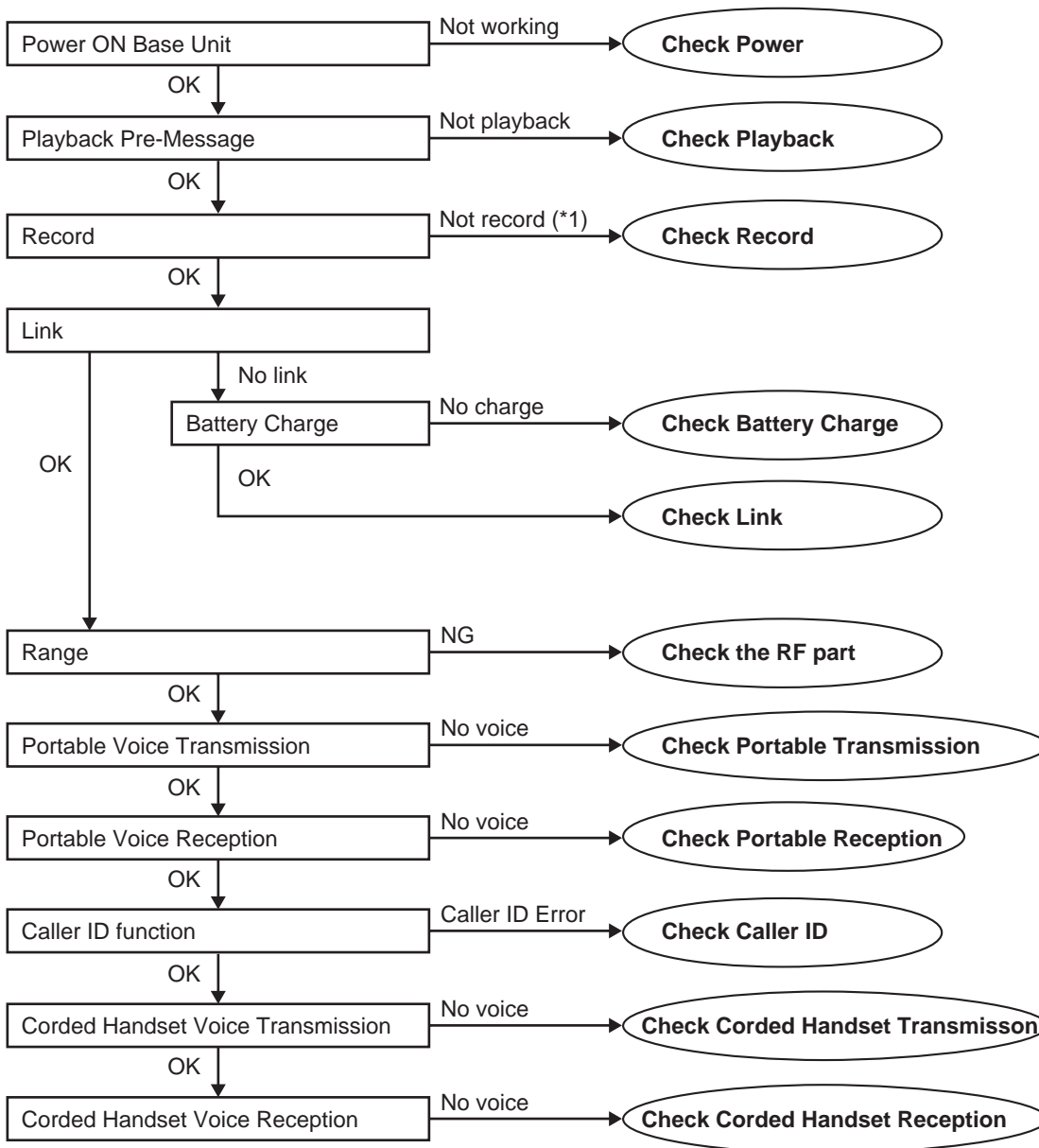

Cross Reference:

Check Power (P.31)

Check Playback (P.35)

Check Record (P.32)

Check Battery Charge (P.35)

Check Link (P.36)

Check the RF part (P.38)

Check Portable Transmission (P.43)

Check Portable Reception (P.43)

Check Caller ID (P.43)

Check SP-phone Transmission (P.43)

Check SP-phone Reception (P.43)

<How to change the Auto Disconnect activation time and VOX level> (P.33) item (A) and (B).

Note:

(*1) When a user claims that the unit disconnects a call right after the greeting message and no incoming messages can be recorded, this symptom can not be reappeared with TEL simulator in the service center. In this case, try to change the Auto disconnect activation time and Vox level.

10.1.1. Check Power

10.1.1.1. Base Unit

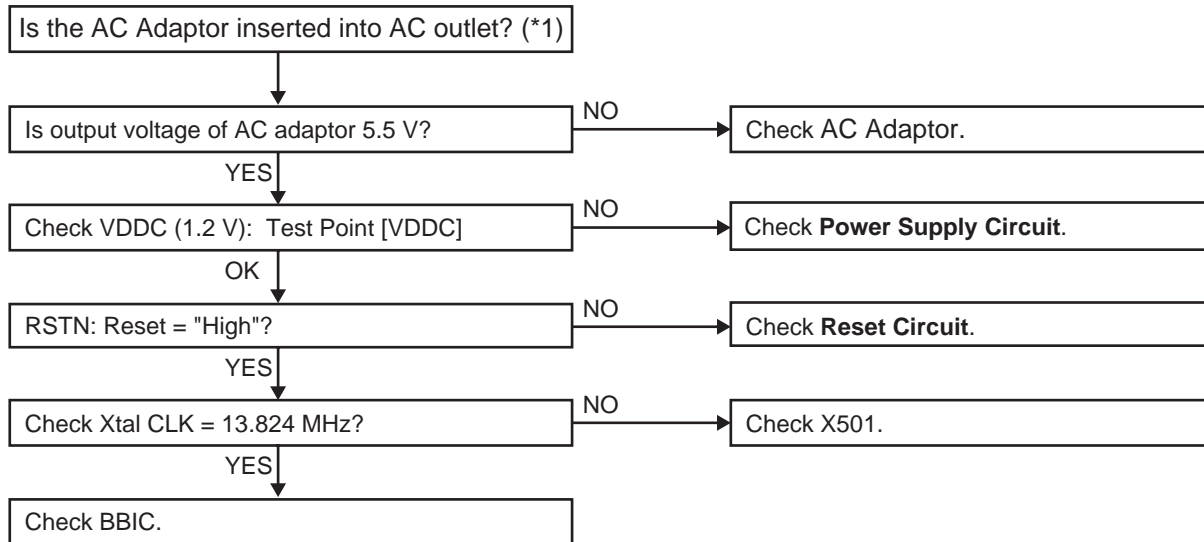

Cross Reference:
Power Supply Circuit/Reset Circuit (P.12)

Note:
BBIC is IC501.
(*1) Refer to **Specifications** (P.6) for part number and supply voltage of AC adaptor.
(*2) Refer to **Circuit Board (Base Unit_Main)** (P.81).

10.1.1.2. Portable

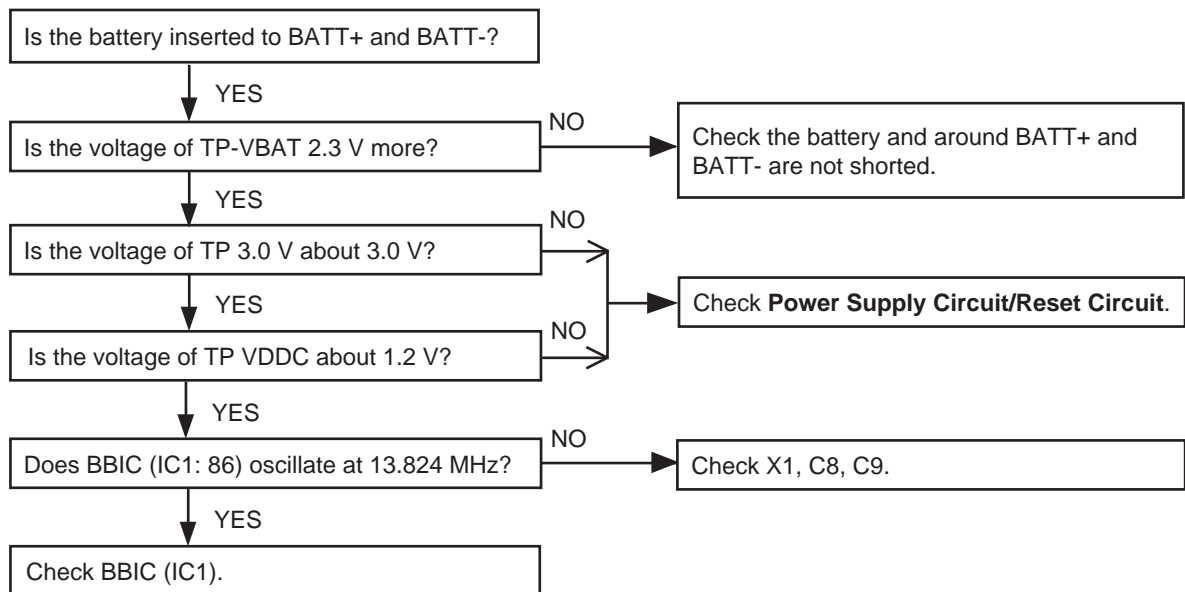

Cross Reference:
Power Supply Circuit/Reset Circuit (P.19)

10.1.2. Check Record

10.1.2.1. Base Unit

Not record Incoming Message

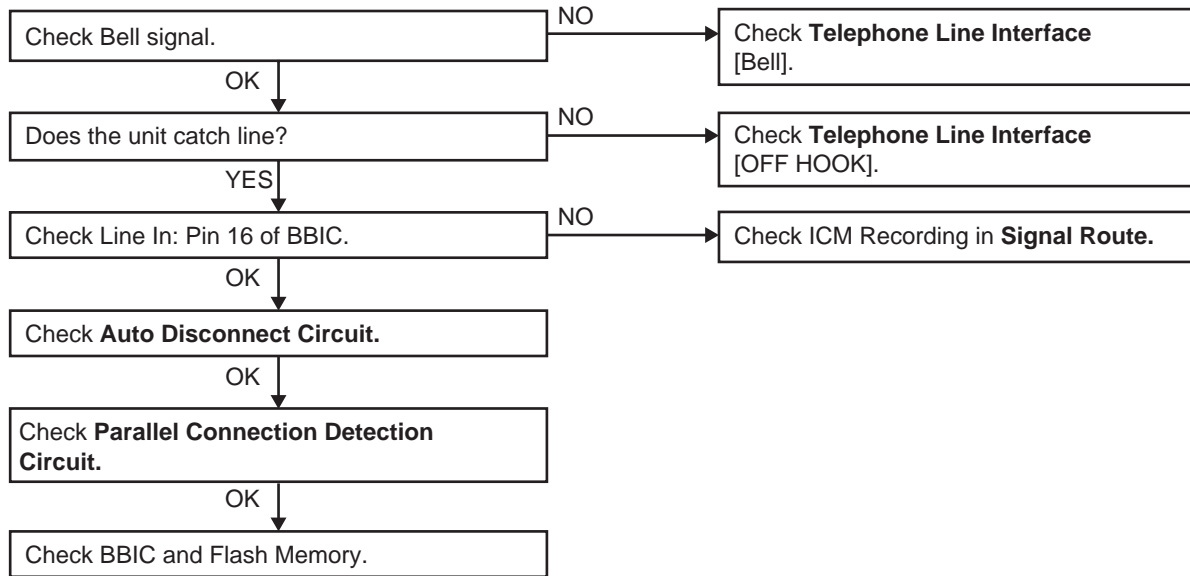

Cross Reference:

Signal Route (P.22)

Telephone Line Interface (P.13)

Parallel Connection Detect Circuit/Auto Disconnect Circuit (P.14)

Note:

Flash Memory is IC601.

BBIC is IC501.

<How to change the Auto Disconnect activation time and VOX level>

A) Auto Disconnect activation time:

Some Telephone Company lines (fiber or cable) ON Hook and OFF Hook voltages are lower than conventional lines, which may cause a malfunction of Auto Disconnect detection. To solve this problem, try changing the Auto Disconnect activation through the procedures below.

- 1) Press "MENU " key at standby Mode and "#" key.

Note: The set must power on and be linked.

- 2) Press "9", "0", "0", "0", " * " .

LCD (H/S)

```
Service ready
: _____
[BACK]
```

- 3) Press "7", "3", "1".

```
Service ready
: 7 3 1 _
[CLEAR]
```

- 4) Then enter the below last digit;

last digit	"0"	Auto disconnect & CPC ^(*1) : enable · · · [default]
	"1"	Auto disconnect : enable ^(*1) CPC : disable
	"2"	Auto disconnect & CPC ^(*2) : disable

Note:

(*1) Both Auto Disconnect and CPC don't detect for the first 2 seconds.

(*2) If the "Disable" is selected, even if the parallel-connected telephone is OFF HOOK, the line isn't disconnected.

- 5) Back to "standby" mode automatically after step 4).
You can hear beep sound which is a confirmation tone.

B) Vox level:

It makes easier to detect a small voice (caller) by raising the sensitivity of VOX level. Therefore, the recording of TAM is not turned off during a detection.

1) ~ 2) are same as (A).

3) Press "5", "1", "1".

```

Service ready
:5 1 1 _
CLEAR

```

4) Then enter the below last digit;

last digit	"0"	default setting : normal
	"1"	6dB up

5) Back to "standby" mode automatically after step 4).
You can hear beep sound which is a confirmation tone.

10.1.3. Check Playback

10.1.3.1. Base Unit

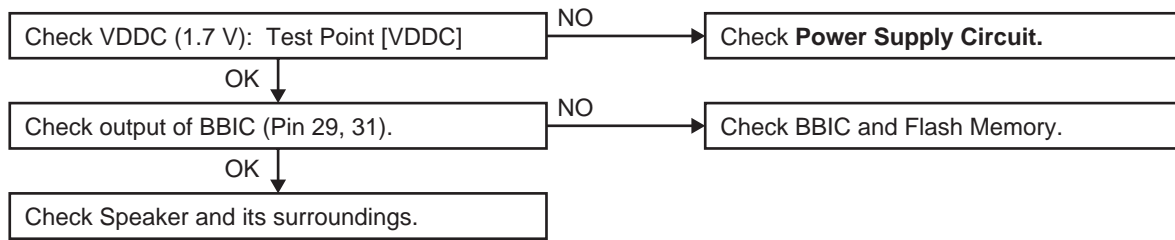

Cross Reference:
Power Supply Circuit/Reset Circuit (P.12)

Note:
 Flash Memory is IC601.
 BBIC is IC1.
 (*1) Refer to **Circuit Board (Base Unit_Main) (P.81)**.

10.1.4. Check Battery Charge

10.1.4.1. Portable

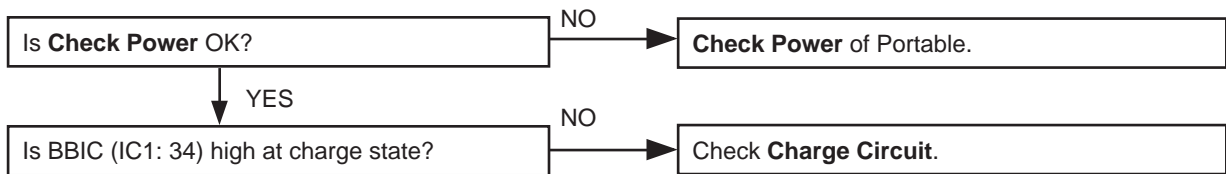

Cross Reference:
Check Power (P.31)
Charge Circuit (P.20)

10.1.4.2. Charger Unit

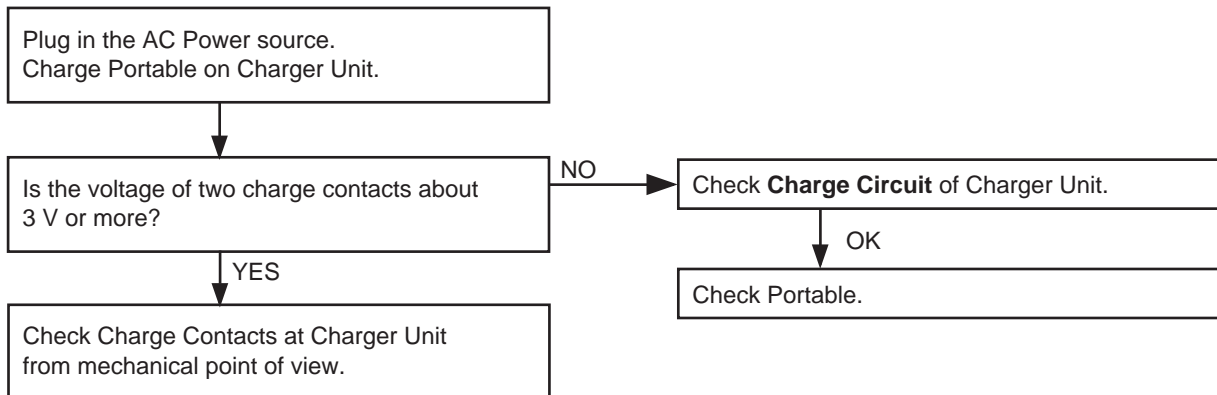

Cross Reference:
Charge Circuit (P.20)

10.1.5. Check Link

10.1.5.1. Base Unit

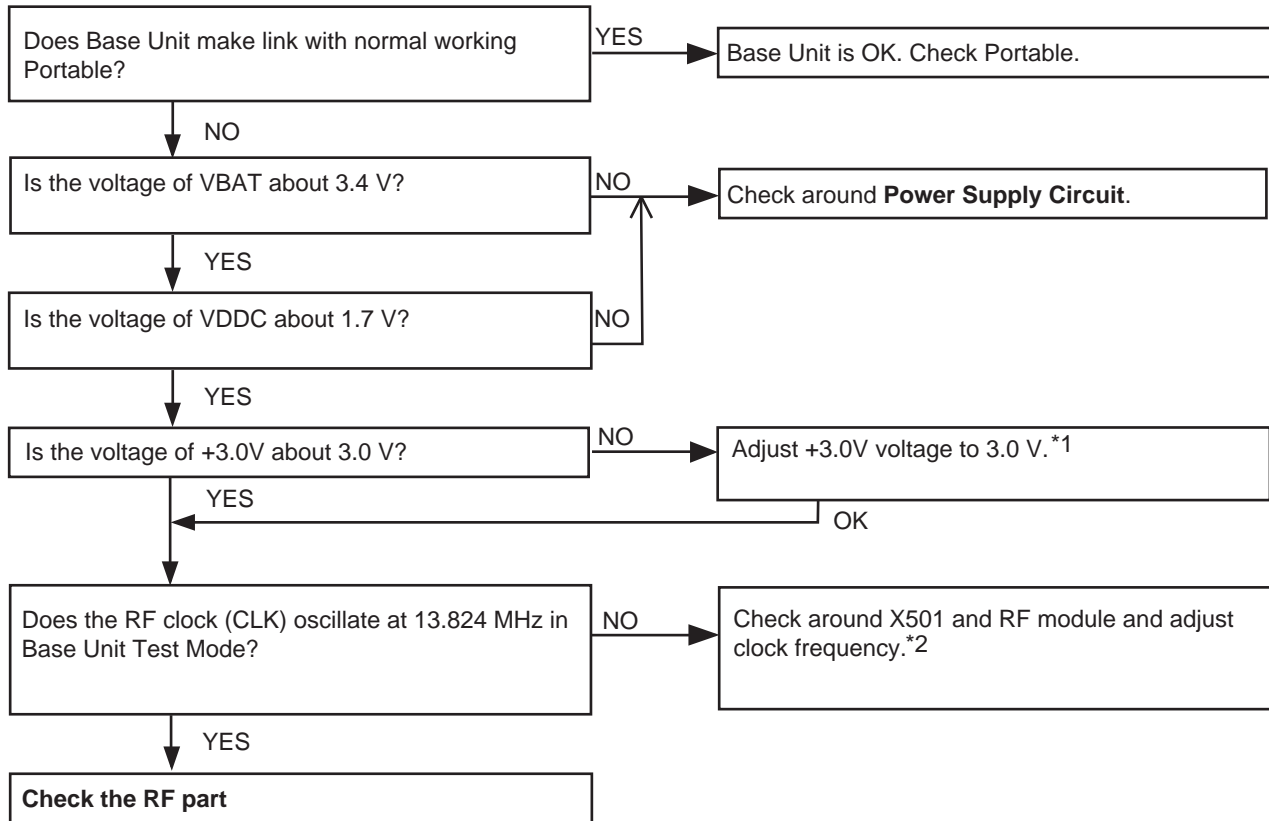

Cross Reference:

Power Supply Circuit/Reset Circuit (P.12)

Check the RF part (P.38)

Note:

*1 How to adjust +3.0V:

Execute the command "VDA"

Refer to **Things to Do after Replacing IC or X'tal** (P.59) for Base Unit.

*2 How to adjust the frequency of X501:

To see the frequency, execute the command "SFR", then check the TP_CKM (IC501-57pin).

To adjust frequency, send command "SFR □○○□○○" until the frequency counter becomes 13.824 MHz±55Hz.

10.1.5.2. Portable

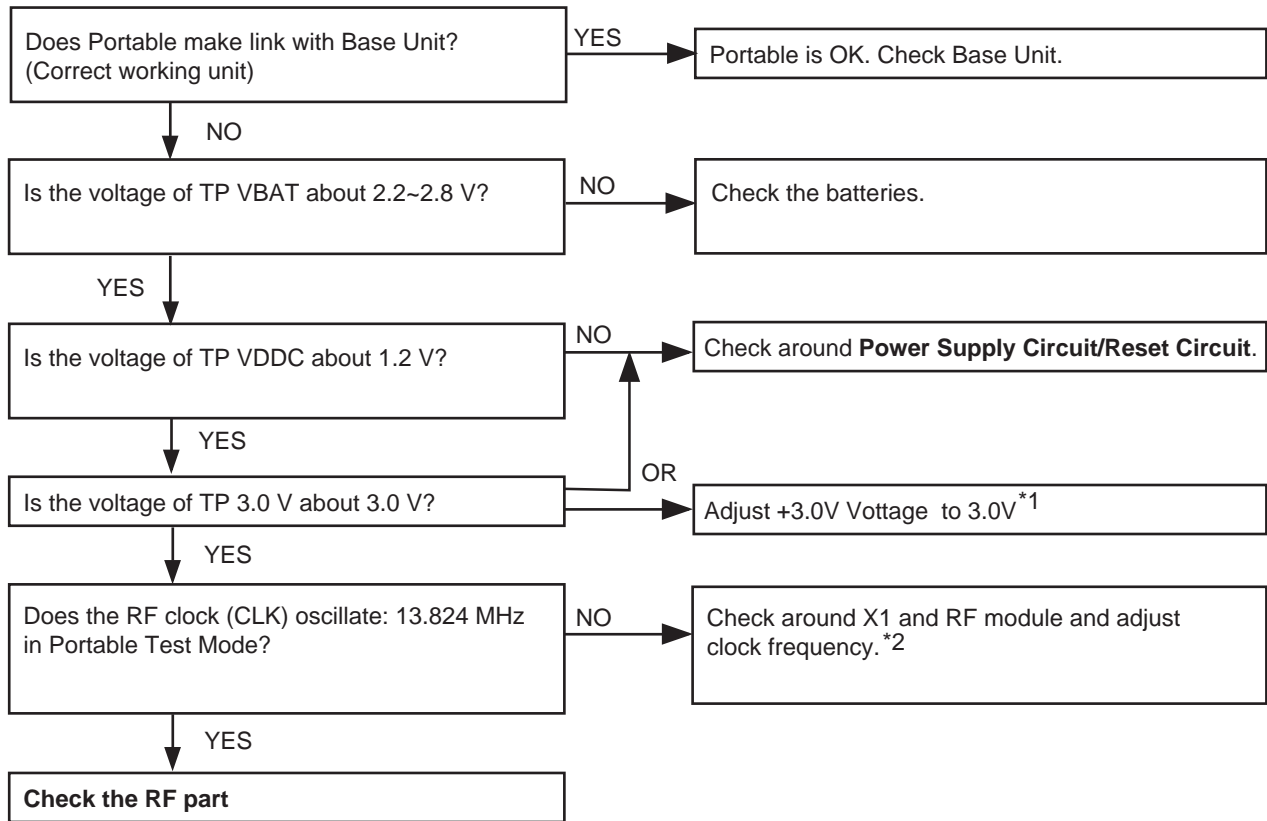

Cross Reference:

Power Supply Circuit/Reset Circuit (P.19)

Check the RF part (P.38)

Note:

*1 How to adjust +3.0V:

Execute the command "VDA"

Refer to **Things to Do after Replacing IC or X'tal** (P.60) for Portable.

*2 How to adjust the frequency of X1:

To see the frequency, execute the command "SFR", then check the TP_CKM (IC1-57pin).

To adjust frequency, send command "SFR □○○□○○" until the frequency counter becomes 13.824 MHz±55HZ.

10.1.6. Check the RF part

10.1.6.1. Finding out the Defective part

1. Prepare Regular P (*1) and Regular BU(*2).
2. a. Re-register regular P (Normal mode) to base unit (to be checked).
If this operation fails in some ways, the base unit is defective.
- b. Re-register portable (to be checked) to regular BU (Normal mode).
If this operation fails in some ways, the portable is defective.

After All the Checkings or Repairing

1. Re-register the checked portable to the checked base unit, and Regular P to Regular BU.

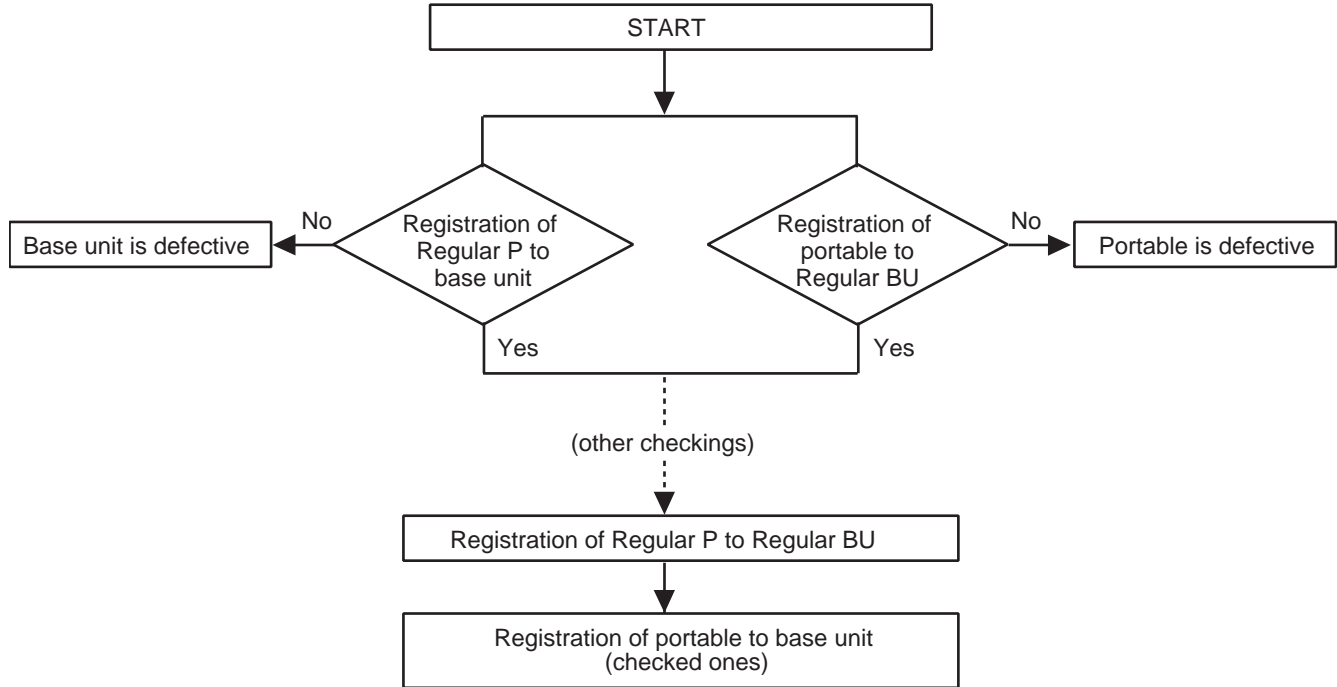

Note:

- (*1) P: Portable
- (*2) BU: Base Unit

10.1.6.2. RF Check Flowchart

Each item (1 ~ 5) of RF Check Flowchart corresponds to **Check Table for RF part** (P.40).
Please refer to the each item.

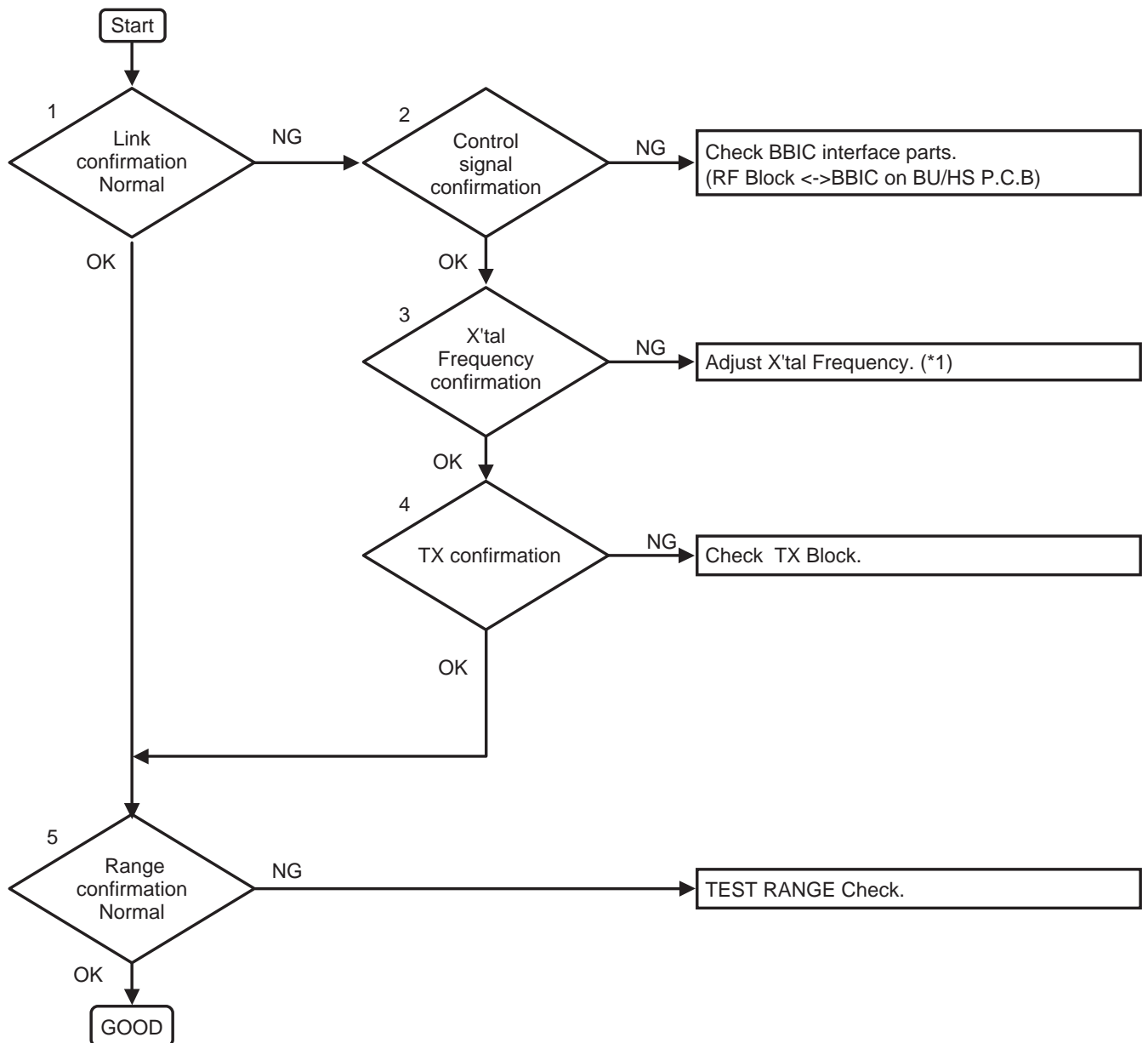

Note:

(*1) Refer to **Check Link** (P.36).

10.1.6.3. Check Table for RF part

No.	Item	BU (Base Unit) Check	P (Portable) Check
1	Link Confirmation Normal P, BU Mode: [Normal Mode]	1. Register Regular P to BU (to be checked). 2. Press [Talk] key of the Regular P to establish link.	1. Register P (to be checked) to Regular BU. 2. Press [Talk] key of the P to establish link.
2	X'tal Frequency confirmation P, BU Mode: [Adjustment]	Check X'tal Frequency. (13.824000 MHz \pm 100 Hz)	Check X'tal Frequency. (13.824000 MHz \pm 100 Hz)
3	TX confirmation P Mode: [P_Burst Mode] (*1) BS Mode: [BS_Burst Mode] (*2)	1. Remove wire antenna 2 and connect spectrum analyzer to TP. (*3) 2. Confirm TX power whether spec. is satisfied. Power \geq 14.5dBm	1. Connect spectrum analyzer to TP.(*4) 2. Confirm TX power whether satisfied spec. Power \geq 16.0dBm
4	Range Confirmation Normal P, BU Mode: [Normal Mode]	1. Register Regular P to BU (to be checked). 2. Press [Talk] key of the Regular P to establish link. 3. Compare the range of the BU (being checked) with that of the Regular BU.	1. Register P (to be checked) to Regular BU. 2. Press [Talk] key of the P to establish link. 3. Compare the range of the P (being checked) with that of the Regular HS.

Note:

- (*1) Refer to **Commands (Portable)** (P.55)
- (*2) Refer to **Commands (Base Unit)** (P.55)
- (*3) **Adjustment Standard (Base Unit)** (P.56)
- (*4) **Adjustment Standard (Portable)** (P.58)

10.1.6.4. TEST RANGE Check

Circuit block which range is defective can be found by the following check.

Item	BU (Base Unit) Check	P (Portable) Check
Range Confirmation TX TEST (TX Power check) P, BU setting Checked unit: Low TX power (*1) Regular unit: High TX power (*1)	<ol style="list-style-type: none"> 1. Register Regular P to BU (to be checked). 2. Set TX Power of the BU and the Regular P according to CHART1. 3. At distance of about 20m between P and BU, Link OK = TX Power of the BU is OK. No Link = TX Power of the BU is NG. 	<ol style="list-style-type: none"> 1. Register P (to be checked) to Regular BU. 2. Set TX Power of the P and the Regular BU according to CHART1. 3. At distance of about 20m between P and BU, Link OK = TX Power of the P is OK. No Link = TX Power of the P is NG.
Range Confirmation RX TEST (RX sensitivity check) P, BU setting Checked unit: High TX power (*1) Regular unit: Low TX power (*1)	<ol style="list-style-type: none"> 1. Register Regular P to BU (to be checked). 2. Set TX Power of the BU and the Regular P according to CHART1. 3. At distance of about 20m between P and BU, Link OK= RX Sensitivity of the BU is OK. No Link = RX Sensitivity of the BU is NG. 	<ol style="list-style-type: none"> 1. Register P (to be checked) to Regular BU. 2. Set TX Power of the Checking P and the Regular BU according to CHART1. 3. At distance of about 20m between P and BU, Link OK= RX Sensitivity of the P is OK. No Link = RX Sensitivity of the P is NG

CHART1: Setting of TX Power and RX Sensitivity in Range Confirmation TX TEST, RX TEST

	BU (to be checked)	Regular_P
	TX Power	TX Power
BU (Base Unit) TX Power Check	Low	High
BU (Base Unit) RX Sensitivity Check	High	Low

	P (to be checked)	Regular_BU
	TX Power	TX Power
P (portable) TX Power Check	Low	High
P (portable) RX Sensitivity Check	High	Low

Note:

(*1) Refer to **Commands (Base Unit)** (P.55).

10.1.7. Registering a Portable to the Base Unit

The supplied portable and base unit are pre-registered. If for some reason the portable is not registered to the base unit, re-register the portable.

1 Portable:

[MENU] # 1 3 0

2 Base unit:

Press and hold **[LOCATOR]** for about 5 seconds until the registration tone sounds.

- If all registered portables start ringing, press **[LOCATOR]** again to stop, then repeat this step.
- The next step must be completed within 90 seconds.

3 Portable:

Press **[OK]**, then wait until a long beep sounds.

Note:

- While registering, “**Base in registering**” is displayed on all registered portables.
- When you purchase an additional portable, refer to the additional portable’s installation manual for registration.

10.1.8. Deregistering a Portable

A portable can cancel its own registration to the base unit, or other portables registered to the same base unit. This allows the portable to end its wireless connection with the system.

1 [MENU] # 1 3 1

- All portables registered to the base unit are displayed.

2 [↕] : Select the portable you want to cancel. → [SELECT]

3 [↕] : “yes” → [SELECT]

4 [OFF]

10.1.9. Check Portable Transmission

Check MIC of portable.

Check portable Tx in **Signal Route**.

Cross Reference:
Signal Route (P.22)

10.1.10. Check Portable Reception

Check speaker of portable.

Check portable Rx in **Signal Route**.

Cross Reference:
Signal Route (P.22)

Note:
When checking the RF part, Refer to **Check the RF part** (P.38).

10.1.11. Check Caller ID

BASE UNIT

Did bell ring?
(Message indicator
blinks)

NO

Check bell signal detection in
Telephone Line Interface.

YES

Check **Calling Line Identification (Caller ID)/
Call Waiting Caller ID**.

Cross Reference:
Telephone Line Interface (P.13)
**Calling Line Identification (Caller ID)/Call Waiting Caller
ID** (P.15)

Note:

- Make sure the format of the Caller ID service of the Telephone company that the customer subscribes to.
- It is also recommended to confirm that the customer is really a subscriber of the service.

10.1.12. Check SP-phone Transmission

Check MIC of Base Unit.

OK

Check SP-phone TX (Base Unit) in **Signal Route**.

Cross Reference:
Signal Route (P.22)

10.1.13. Check SP-phone Reception

Check Speaker of Base Unit.

OK

Check SP-phone RX (Base Unit) in **Signal Route**.

Cross Reference:
Signal Route (P.22)

10.1.14. Check Corded Handset Transmission

Check (Corded) Handset.

OK

Check (Corded) Handset TX in **Signal Route**.

Cross Reference:
Signal Route (P.22)

10.1.15. Check Corded Handset Reception

Check (Corded) Handset.

OK

Check (Corded) Handset RX in **Signal Route**.

Cross Reference:
Signal Route (P.22)

11 Disassembly and Assembly Instructions

11.1. Disassembly Instructions

11.1.1. Base Unit

- ① Remove the 8 screws to remove the cabinet cover.

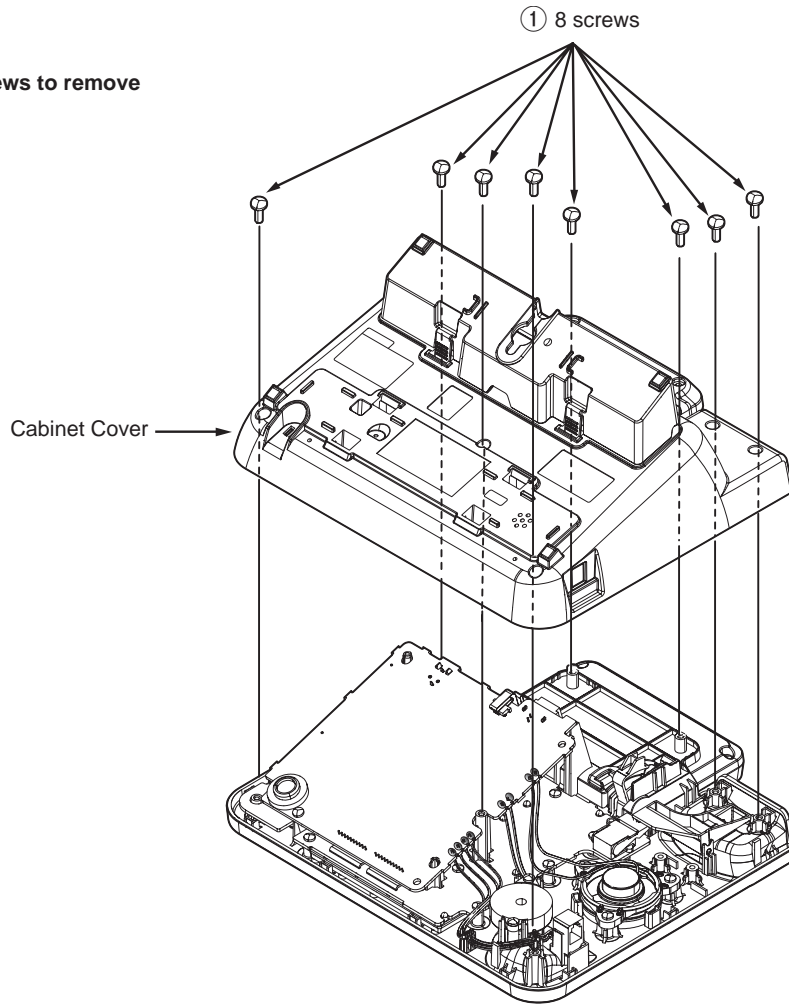

- ② Remove 2 screws, Parallel wire and solders to remove the main P.C. Board.

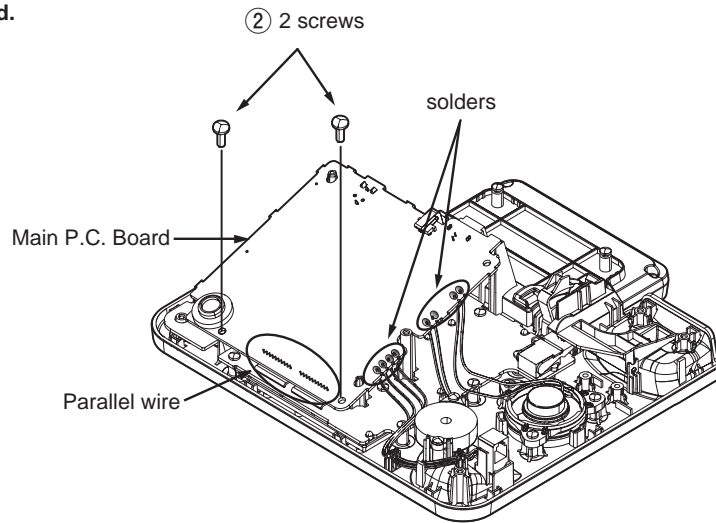

- ③ Unhook the hook and remove the 9 screws to remove the operational P.C. board.

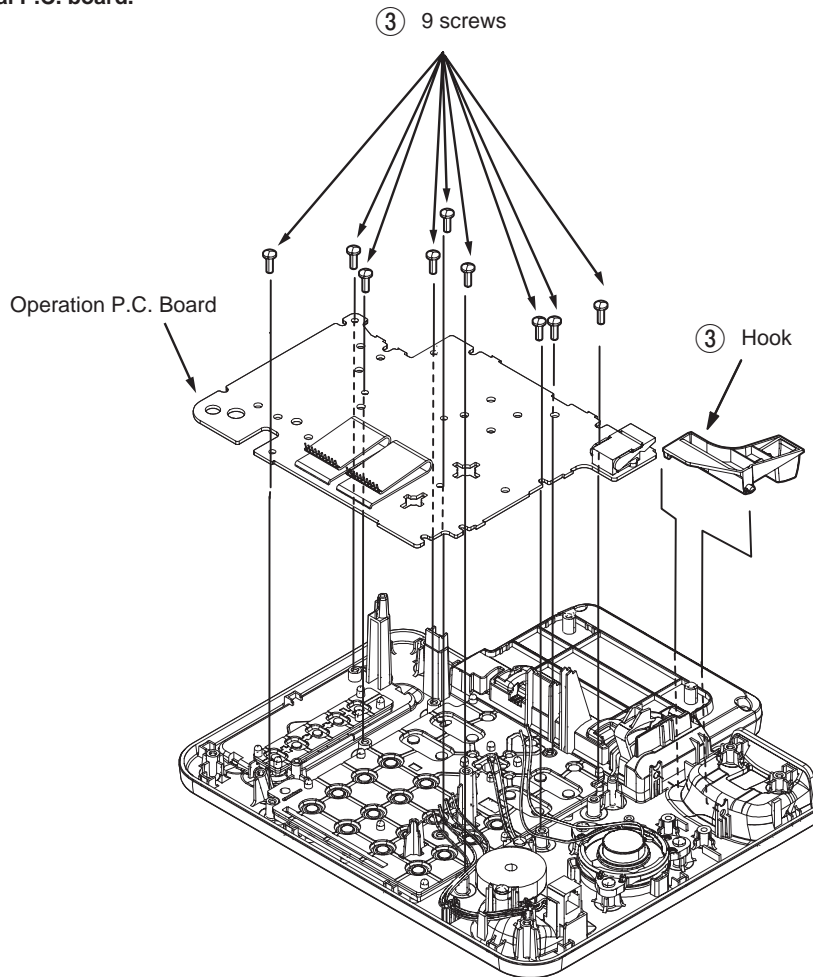

- ④ Remove the 2 screws to remove the LCD Unit.

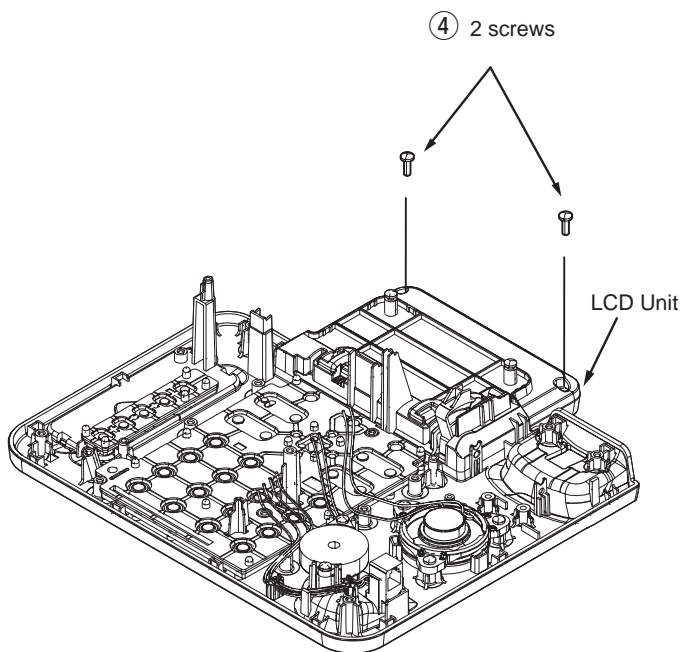

- 5 Remove solders and connectors to remove the LCD P.C. board.

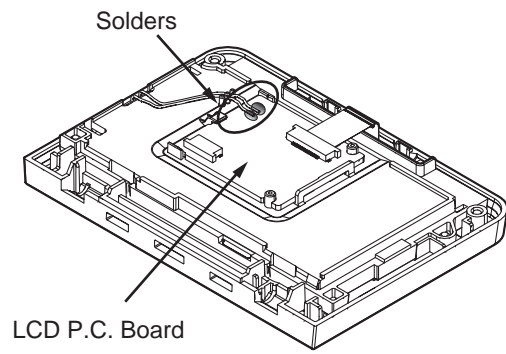

11.1.2. Portable

- ① Remove the 2 screws.

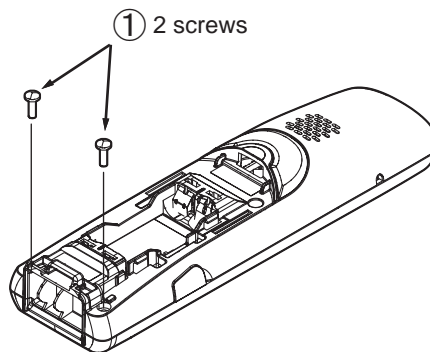

- ② Insert a plastic card. (Ex. Used SIM card etc.) between the cabinet body and the cabinet cover, then pull it along the gap to open the cabinet.

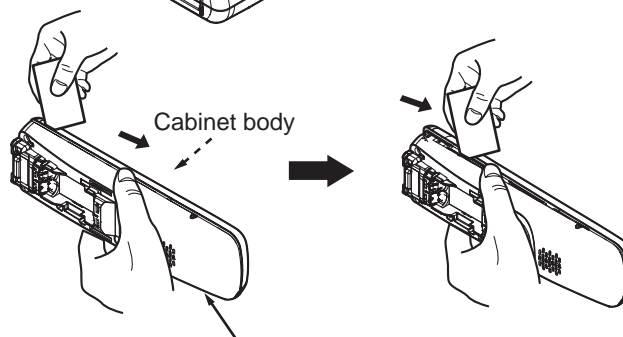

- ③ Likewise, open the other side of the cabinet.

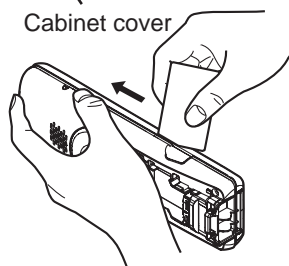

- ④ Remove the cabinet cover by pushing it upward.

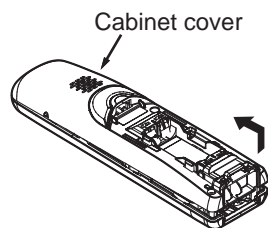

- ⑤ Remove the solders and tape.

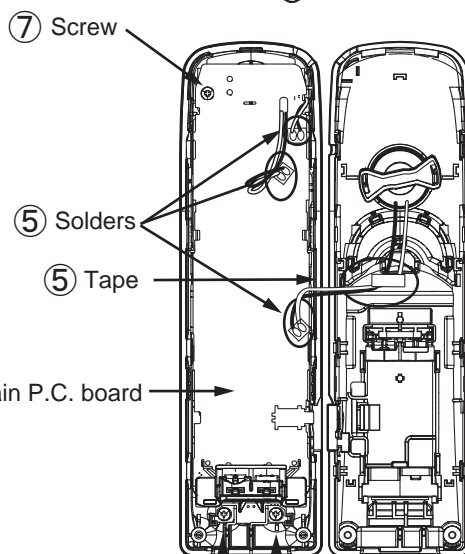

- ⑥ Remove the 2 screws to remove the 2 charge terminals.

- ⑦ Remove the screw to remove the main P. C. board.

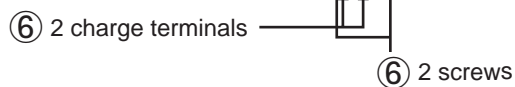

11.1.3. Charger Unit

- ① Remove the screw to remove the cabinet cover.

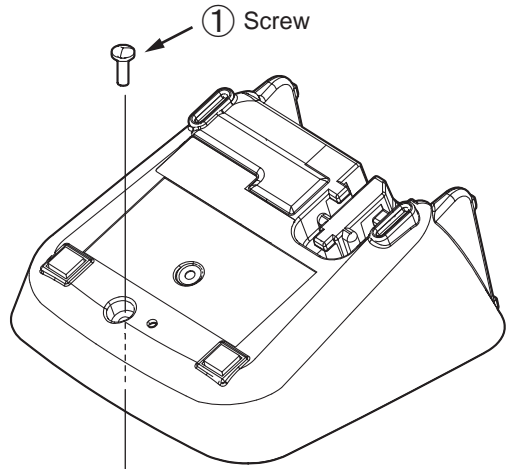

- ② Remove the solders to remove the 2 charge terminals.

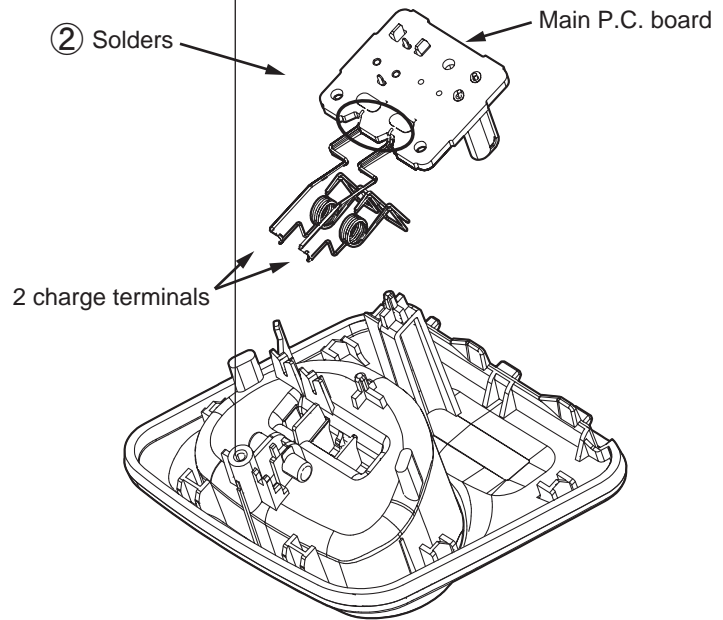

11.2. Assembly Instructions

11.2.1. How to Replace the Base unit LCD

①

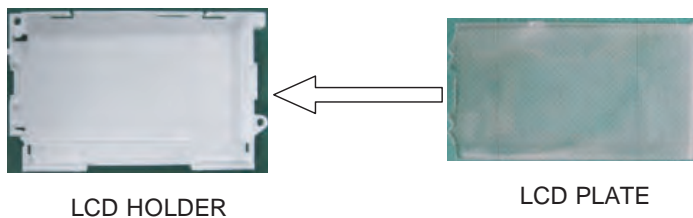

②

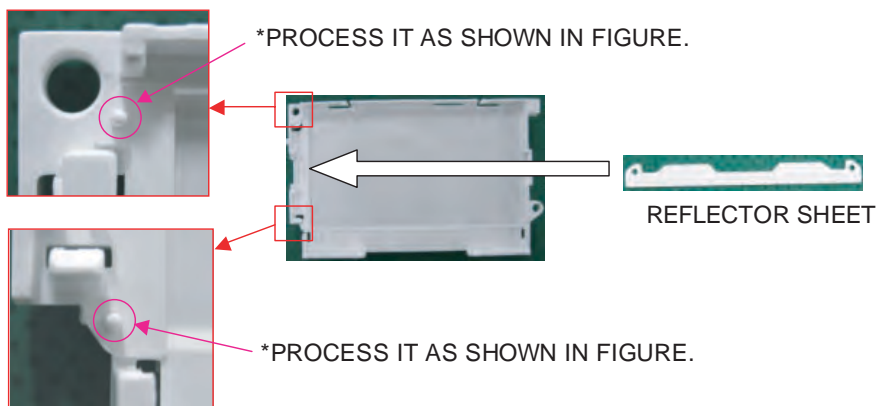

③

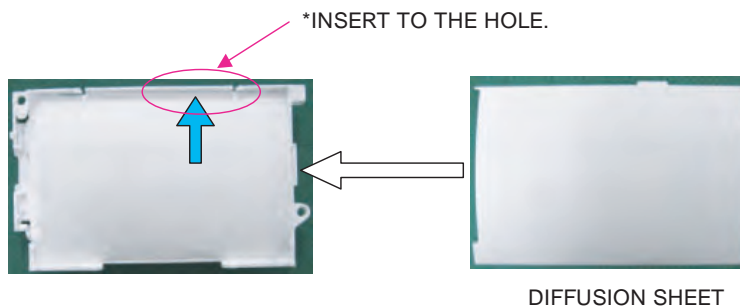

④

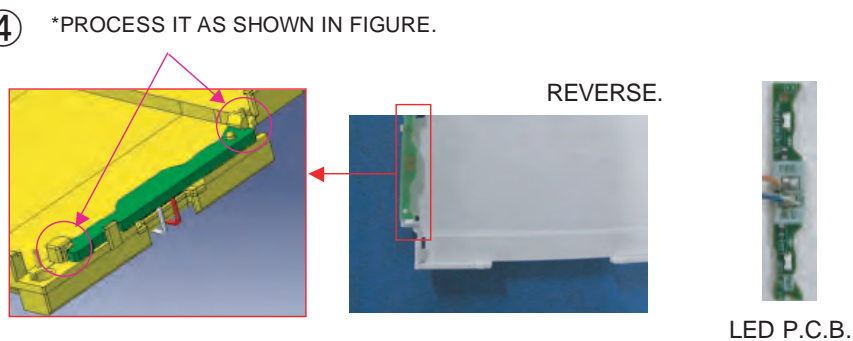

⑤

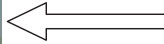

LCD

Attach LCD P.C.B under conditions to push edge face.

⑥

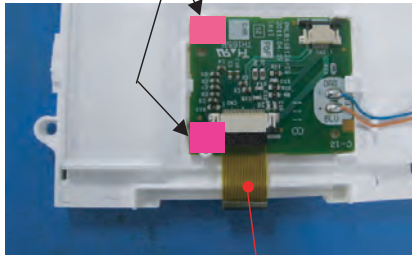

LCD P.C.B.

⑦



FFC/8

⑧

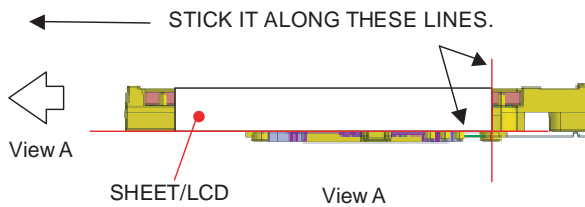

⑨



GRILL/LCD

⑩

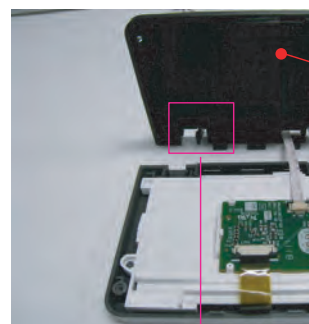

COVER/LCD

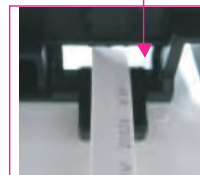

*INSERT FFC IN THE HOLE OF COVER/LCD.

11.3. How to Replace the Portable LCD

Note:

The illustrations are simplified in this page.
They may differ from the actual product.

①

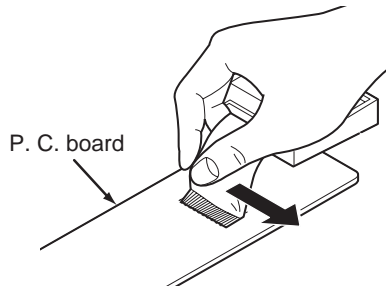

Peel off the FFC (Flexible Flat Cable) from the LCD, in the direction of the arrow. Take care to ensure that the foil on the P.C. board is not damaged.

②

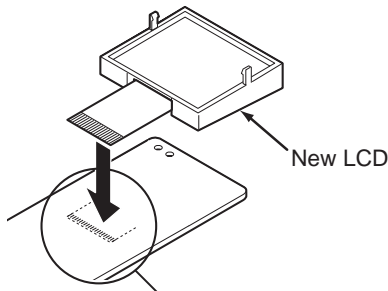

Fit the heatseal of a new LCD.

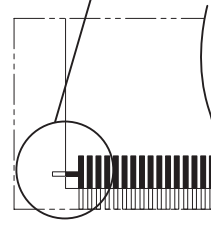
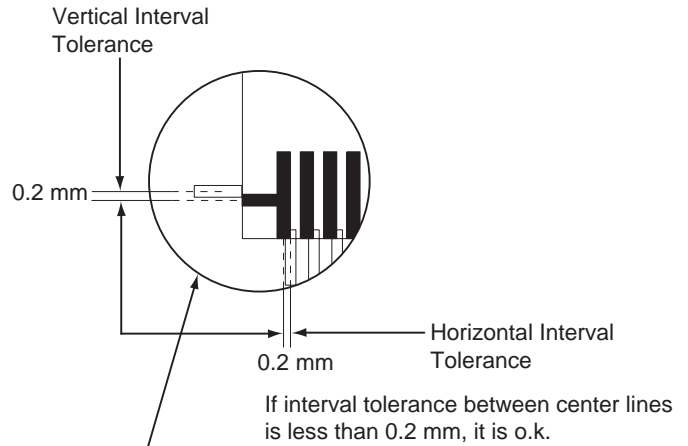

③

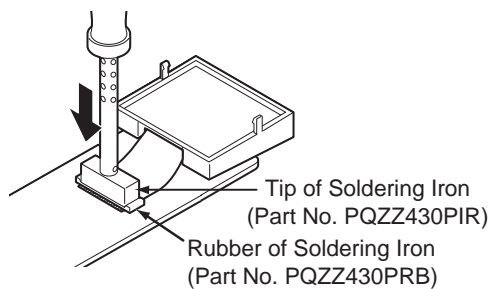

Heatweld with the tip of the soldering iron about 5 to 8 seconds (in case of 60W soldering iron).

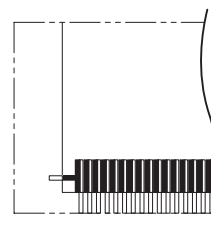
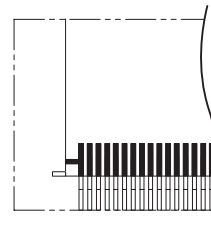
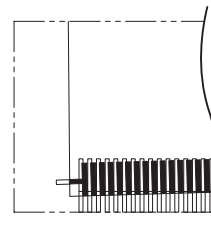

12 Measurements and Adjustments

This chapter explains the measuring equipment, the JIG connection, and the PC setting method necessary for the measurement in **Troubleshooting Guide** (P.30)

12.1. Equipment Required

- Digital multi-meter (DMM): it must be able to measure voltage and current.
- Oscilloscope.
- Frequency counter: It must be precise enough to measure intervals of 1 Hz (precision; ± 4 ppm)
Hewlett Packard, 53131A is recommended.
- DECT tester: Rohde & Schwarz, CMD 60 is recommended.
This equipment may be useful in order to precisely adjust like a mass production.

12.2. The Setting Method of JIG

<Preparation>

- Serial JIG cable: PQZZ1CD300E*
- PC which runs in DOS mode
- **Batch file CD-ROM** for setting: PNZZTG6671B

Note:

*: If you have the JIG Cable for TCD500 series (PQZZ1CD505E), change the following values of resistance. Then you can use it as a JIG Cable for both TCD300 and TCD500 series. (It is an upper compatible JIG Cable.)

Resistor	Old value (k Ω)	New value (k Ω)
R2	22	3.3
R3	22	3.3
R4	22	4.7
R7	4.7	10

12.2.1. Connections (Base Unit)

- ① Connect the AC adaptor.
- ② Connect the JIG Cable GND (black).
- ③ Connect the JIG Cable RX (red) and TX (yellow).

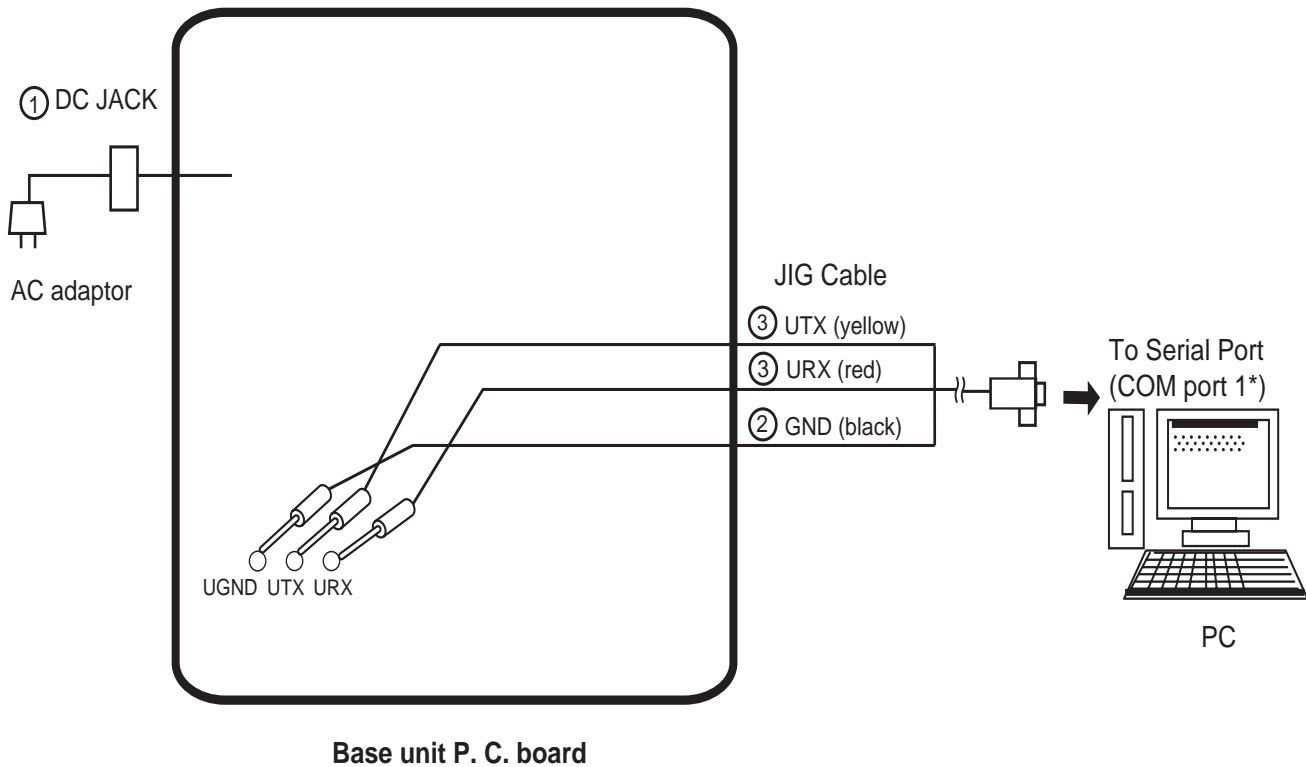

Note:

*: COM port names may vary depending on what your PC calls it.

12.2.2. Connections (Portable)

- ① Connect the DC Power or Battery to BATT+ and BATT-.
- ② Connect the JIG cable GND (black) to GND.
- ③ Connect the JIG cable UTX (yellow) to UTX and URX (red) to URX.

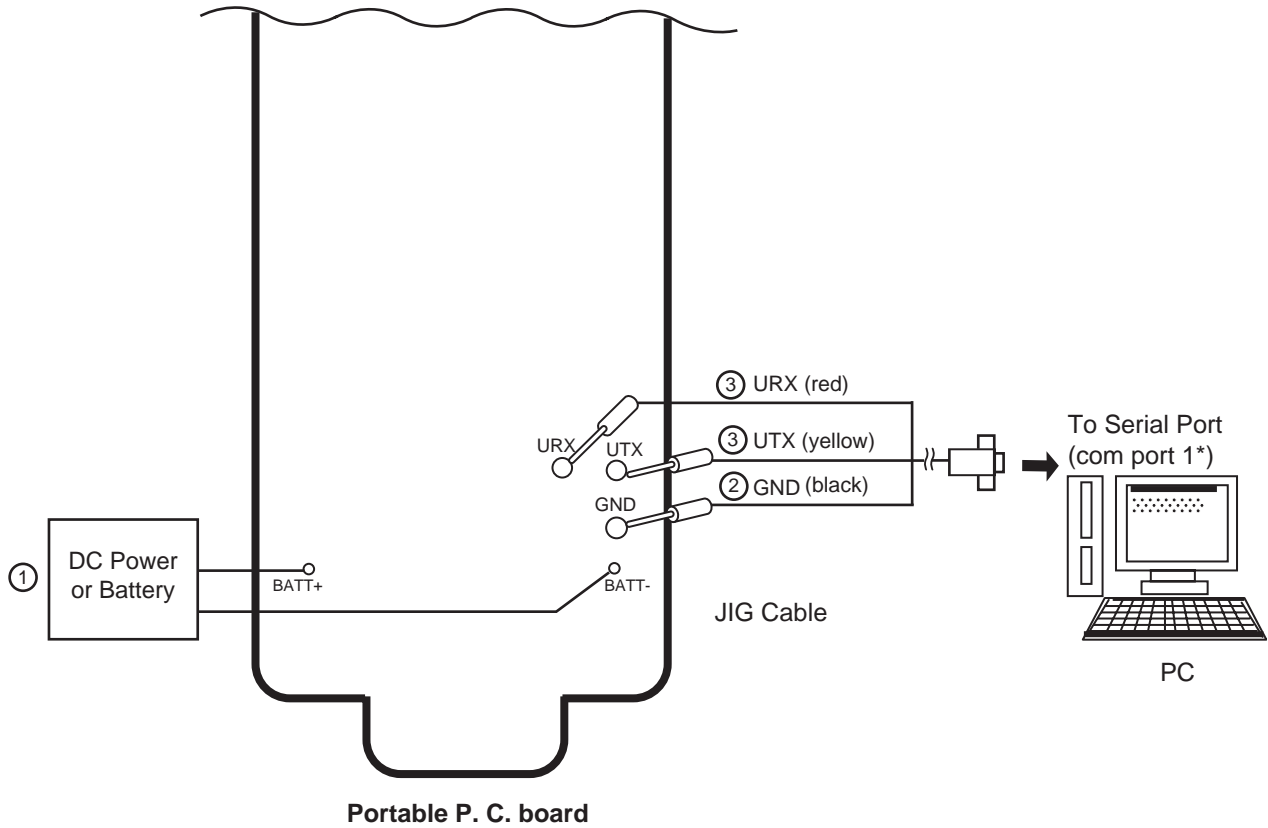

Note:

*: COM port names may vary depending on what your PC calls it.

12.2.3. How to install Batch file into P.C.

1. Insert the Batch file CD-ROM into CD-ROM drive and copy PNZZTG**** folder to your PC (example: D drive).

2. Open an MS-DOS mode window.

3. At the DOS prompt, type "D:" (for example) to select the drive, then press the **Enter** key.

4. Type "CD ¥PNZZTG****", then press the **Enter** key.

5. Type "SET_COM=X", then press the **Enter** key (X: COM port number used for the serial connection on your PC).

6. Type "READID", then press the **Enter** key.
 • If any error messages appear, change the port number or check the cable connection.
 • If any value appear, go to next step.

7. Type "DOSKEY", then press the **Enter** key.

<Example for Windows>

On your computer, click **[Start]**, select **Programs** (**All Programs** for Windows XP/Windows Server 2003), then click
MS-DOS Prompt. (for Windows 95/Windows 98)
 Or
Accessories-MS-DOS Prompt. (for Windows Me)
 Or
Command Prompt. (for Windows NT 4.0)
 Or
Accessories-Command Prompt. (for Windows 2000/Windows XP/Windows Server 2003)

<Example>

```
C: ¥Documents and Settings>D:
D: ¥>CD ¥PNZZTG****
D: ¥PNZZTG**** >SET_COM=X
D: ¥PNZZTG****>READID
00 52 4F A8 A8
D: ¥PNZZTG****>DOSKEY
D: ¥PNZZTG****>_
```

<Example: error happens>

```
C: ¥Documents and Settings>D:
D: ¥>CD ¥PNZZTG****
D: ¥PNZZTG**** >SET_COM=X
D: ¥PNZZTG****>READID
CreateFile error
ERROR 10: Can't open serial port
D: ¥PNZZTG ****>_
```

Note:

- "****" varies depending on the country or models.

12.2.4. Commands (Base Unit)

See the table below for frequently used commands.

Command name	Function	Example
rdeeprom	Read the data of EEPROM	Type "rdeeprom 00 00 FF", and the data from address "00 00" to "FF" is read out.
readid	Read ID (RFPI)	Type "readid", and the registered ID is read out.
writeid	Write ID (RFPI)	Type "writeid 00 18 E0 0E 98", and the ID "0018 E0 0E 98" is written.
hookoff	Off-hook mode on Base	Type "hookoff".
hookon	On-hook mode on Base	Type "hookon".
getchk	Read checksum	Type "getchk".
How to use of "getchk"	1.rdeeprom	Read EEPROM Type "RdEeprom 04 73 04", and the data from address "03 F2" to "03 F5" is read out *This command gets 4 byte "WW", "XX", "YY", "ZZ". *Please NEVER forget these 4 byte data!
	2.sendchar epw	Write EEPROM Type "sendchar epw 04 73 04 FF FF FF FF"
	3.sendchar RST	Reset baseset Type "sendchar RST"
	4.getchk	Read checksum Type "getchk".
	5.sendchar epw	Write EEPROM Type "sendchar epw 04 73 04 WW XX YY ZZ" *"WW", "XX", "YY", "ZZ" is 4 byte data that already read from same address.
wreeprom	Write the data of EEPROM	Type "wreeprom 01 23 45". "01 23" is address and "45" is data to be written.
bs_burst	Base unit outputs RF power in burst test mode on antenna 2	Type "bs_burst"
tx_high	Keep TX power high	Type "tx_high"
tx_low	Keep TX power low	Type "tx_low"

12.2.5. Commands (Portable)

See the table below for frequently used commands.

Command name	Function	Example
rdeeprom	Read the data of EEPROM	Type "rdeeprom 00 00 FF", and the data from address "00 00" to "FF" is read out.
readid	Read ID (RFPI)	Type "readid", and the registered ID is read out.
writeid	Write ID (RFPI)	Type "writeid 00 18 E0 0E 98", and the ID "0018 E0 0E 98" is written.
getchk	Read checksum	Type "getchk"
How to use of "getchk"	1.rdeeprom	Read EEPROM Type "RdEeprom 03 7D 04", and the data from address "03 7D" to "03 80" is read out *NEVER forget the read 4 byte data!
	2.sendchar epw	Write EEPROM Type "sendchar epw 03 7D 04 FF FF FF FF"
	3.sendchar RST	Reset baseset Type "sendchar RST"
	4.getchk	Read checksum Type "getchk".
	5.sendchar epw	Write EEPROM Type "sendchar epw 03 7D 04 WW XX YY ZZ" *"WW", "XX", "YY", "ZZ" is 4 byte data that already read from same address.
wreeprom	Write the data of EEPROM	Type "wreeprom 01 23 45". "01 23" is address and "45" is data to be written.
hs_burst	Portable outputs RF power in burst test mode	Type "hs_burst"
tx_high	Keep TX power high	Type "tx_high"
tx_low	Keep TX power low	Type "tx_low"

12.4. Adjustment Standard (Charger Unit)

When connecting the simulator equipment for checking, please refer to below.

12.4.1. Bottom View

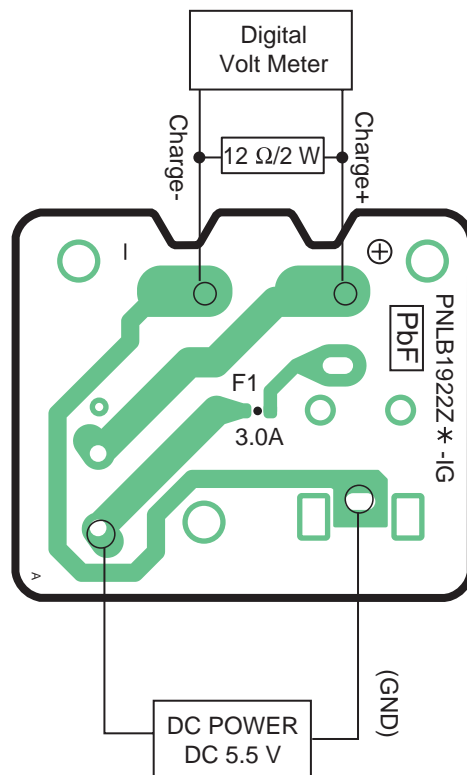

12.5. Adjustment Standard (Portable)

When connecting the simulator equipment for checking, please refer to below.

12.5.1. Component View

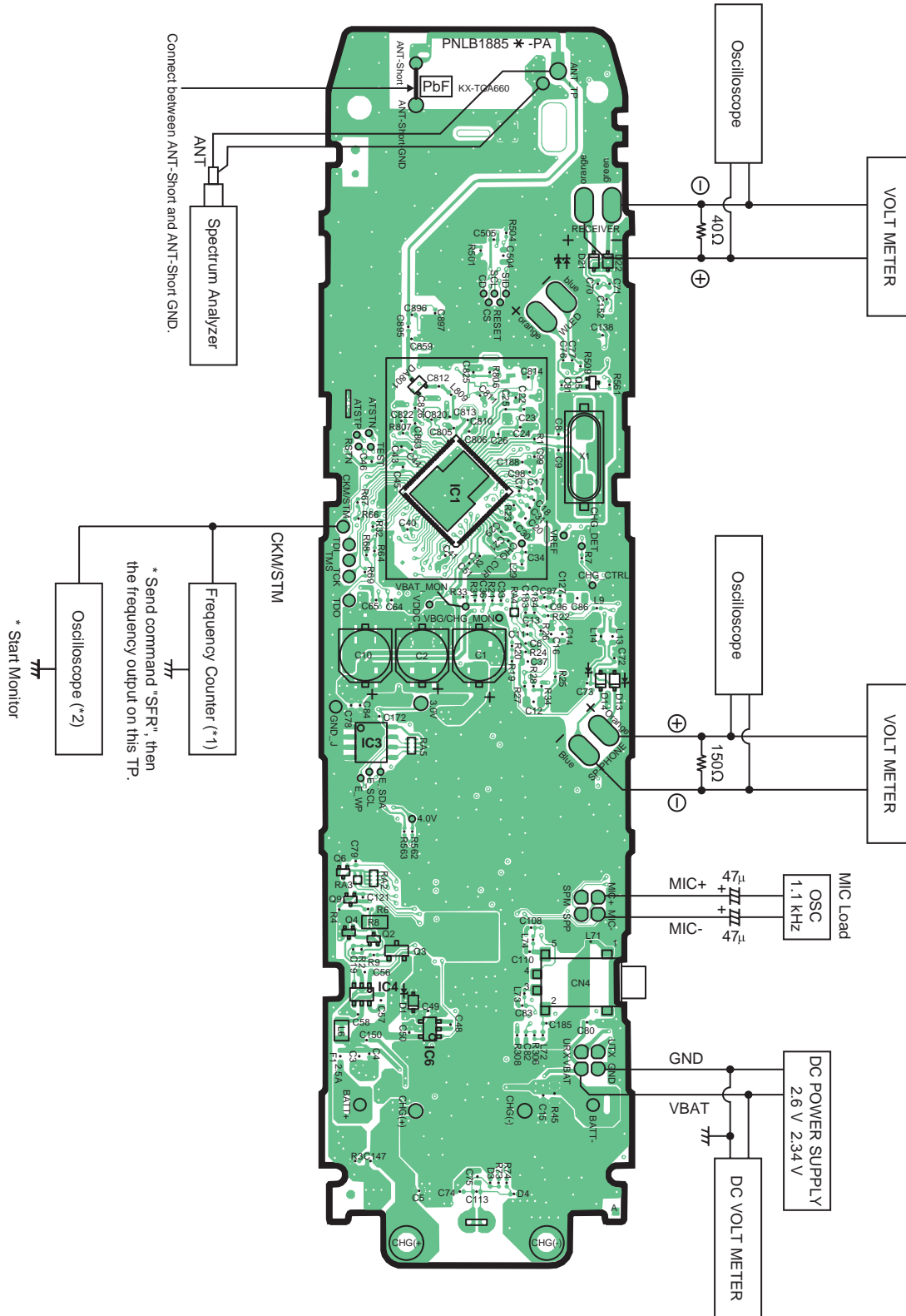

Note:

- (*1) is referred to No.2 of Check **Check Table for RF part** (P.40)
- (*2) is referred to **Power Supply Circuit/Reset Circuit** (P.19)

12.6. Things to Do after Replacing IC or X'tal

If repairing or replacing EEPROM and X'tal, it is necessary to download the required data such as Programming data or adjustment data, etc in memory.

The set doesn't operate if it is not executed.

12.6.1. How to download the data

12.6.1.1. Base Unit

First, operate the PC setting according to **The Setting Method of JIG** (P.52).

Then download the appropriate data according to the following procedures.

Items		How to download/Required adjustment
EEPROM (IC611)	Adjusted parameter data is stored in memory. (country version batch file, default batch file, etc.)	1) Change the address "0001" of EEPROM to "AA" to download the data. 2) Default batch file: Execute the command "default.bat". 3) Country version batch file: Execute the command "TG6671US_RevXXX.bat". (*1) 4) Clock adjustment
X'tal (X1)	System clock	Clock adjustment data is in EEPROM, adjust the data again after replacing it. 1) Apply 5.5V between DCP and DCM with DC power. 2) Input Command "sendchar sfr", then you can confirm the current value. 3) Check X'tal Frequency.(13.824 MHz \pm 100 Hz). 4) If the frequency is not 13.824 MHz \pm 100 Hz, adjust the frequency of CLK executing the command "sendchar sfr xx xx (where xx is the value)" so that the reading of the frequency counter is 13.824000 MHz \pm 15 Hz.

Note:

(*1) XXX: revision number

"XXX" vary depending on the country version. You can find them in the batch file, PNZZ- mentioned in **The Setting Method of JIG** (P.52).

12.6.1.2. Portable

First, operate the PC setting according to **The Setting Method of JIG** (P.52).

Then download the appropriate data according to the following procedures.

Items		How to download/Required adjustment
EEPROM (IC3)	Adjusted parameter data is stored in memory. (country version batch file, default batch file, etc.)	<ol style="list-style-type: none"> 1) Default batch file: Execute the command "default.bat". 2) Default batch file (remaining): Execute the command "TGA660US_DEF_RevXXX_YYY.bat". (*2) 3) Country version batch file: Execute the command "TGA660US_US_RevXXX_YYY.bat". (*2) 4) Clock adjustment 5) 2.35 V setting and battery low detection
X'tal (X1)	System clock	<ol style="list-style-type: none"> 1) Apply 2.6V between BATT+ and BATT- with DC power. 2) Input Command "sendchar sfr", then you can confirm the current value. 3) Check X'tal Frequency.(13.824 MHz \pm 100 Hz). 4) If the frequency is not 13.824 MHz \pm 100 Hz, adjust the frequency of CLK executing the command "sendchar sfr xx xx (where xx is the value)" so that the reading of the frequency counter is 13.824000 MHz \pm 5 Hz.

Note:

(*2) XXX_YYY: revision number

"XXX" and "YYY" vary depending on the country version. You can find them in the batch file, PNZZ- mentioned in **The Setting Method of JIG** (P.52).

12.7. Frequency Table

	Ch. (hex)	TX/RX Frequency (MHz)
Channel 0	00	1928.448
Channel 1	01	1926.720
Channel 2	02	1924.992
Channel 3	03	1923.264
Channel 4	04	1921.536

13 Miscellaneous

13.1. How to Replace the LLP (Leadless Leadframe Package) IC

Note:

This description is only applied on the model with Shield case.

13.1.1. Preparation

- PbF (: Pb free) Solder
- Soldering Iron
Tip Temperature of 700 °F ± 20 °F (370 °C ± 10 °C)

Note:

We recommend a 30 to 40 Watt soldering iron. An expert may be able to use a 60 to 80 Watt iron where someone with less experience could overheat and damage the PCB foil.

- Hot Air Desoldering Tool
Temperature: 608 °F ± 68 °F (320 °C ± 20 °C)

13.1.2. Caution

- To replace the IC efficiently, choose the right sized nozzle of the hot air desoldering tool that matches the IC package.
- Be careful about the temperature of the hot air desoldering tool not to damage the PCB and/or IC.

13.1.3. How to Remove the IC

1. Heat the IC with a hot air desoldering tool through the P.C.Board.

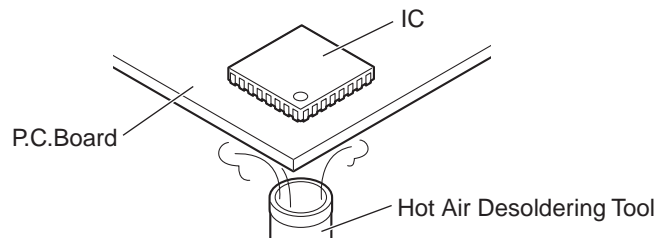

2. Pick up the IC with tweezers, etc. when the solder is melted completely.

Note:

- Be careful not to touch the peripheral parts with tweezers, etc. They are unstable.

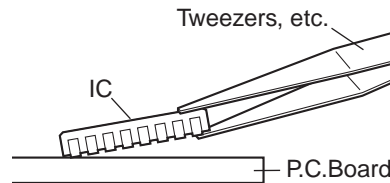

When it is hard to melt the solder completely, heat it with a hot air desoldering tool through the IC besides through the P.C.Board.

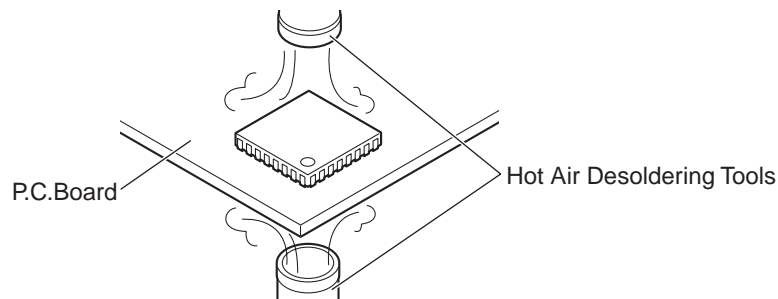

3. After removing the IC, clean the P.C.Board of residual solder.

13.1.4. How to Install the IC

1. Place the solder a little on the land where the radiation GND pad on IC bottom is to be attached.

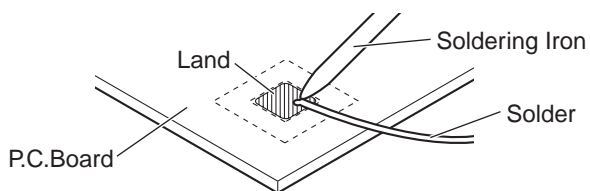

2. Place the solder a little on the land where IC pins are to be attached, then place the IC.

Note:

- When placing the IC, the positioning should be done very carefully.

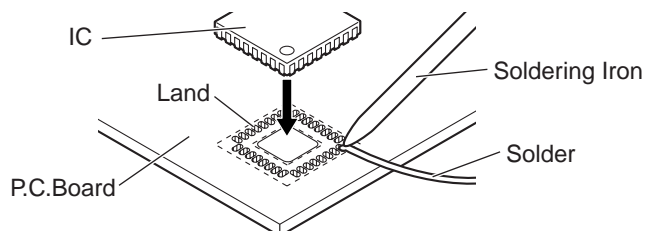

3. Heat the IC with a hot air desoldering tool through the P.C.Board until the solder on IC bottom is melted.

Note:

- Be sure to place it precisely, controlling the air volume of the hot air desoldering tool.

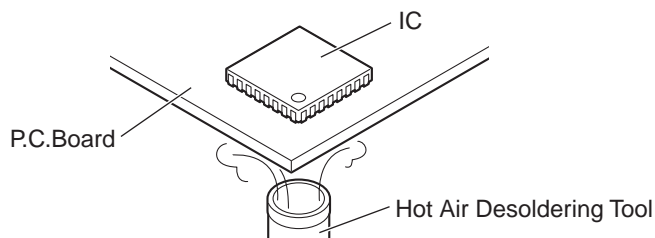

4. After soldering, confirm there are no short and open circuits with visual inspection.

13.2. How to Replace the Flat Package IC

Even if you do not have the special tools (for example, a spot heater) to remove the Flat IC, with some solder (large amount), a soldering iron and a cutter knife, you can easily remove the ICs that have more than 100 pins.

13.2.1. Preparation

- PbF (: Pb free) Solder
- Soldering Iron

Tip Temperature of 700 °F ± 20 °F (370 °C ± 10 °C)

Note: We recommend a 30 to 40 Watt soldering iron. An expert may be able to use a 60 to 80 Watt iron where someone with less experience could overheat and damage the PCB foil.

- Flux

Recommended Flux: Specific Gravity → 0.82.

Type → RMA (lower residue, non-cleaning type)

Note: See **About Lead Free Solder (PbF: Pb free)** (P.4)

13.2.2. How to Remove the IC

1. Put plenty of solder on the IC pins so that the pins can be completely covered.

Note:

If the IC pins are not soldered enough, you may give pressure to the P.C. board when cutting the pins with a cutter.

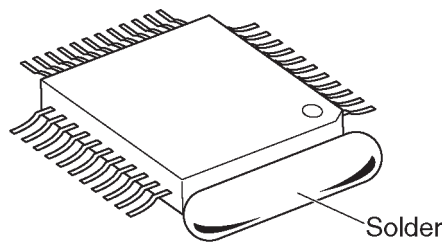

2. Make a few cuts into the joint (between the IC and its pins) first and then cut off the pins thoroughly.

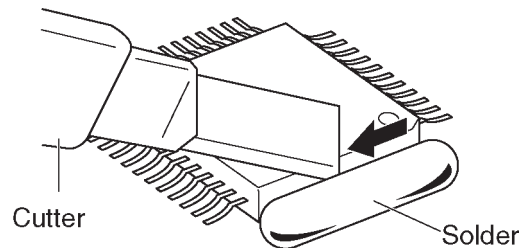

3. While the solder melts, remove it together with the IC pins.

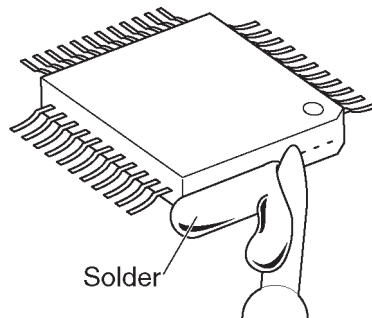

When you attach a new IC to the board, remove all solder left on the board with some tools like a soldering wire. If some solder is left at the joint on the board, the new IC will not be attached properly.

13.2.3. How to Install the IC

1. Temporarily fix the FLAT PACKAGE IC, soldering the two marked pins.

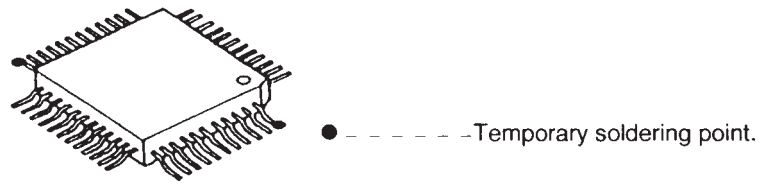

*Check the accuracy of the IC setting with the corresponding soldering foil.

2. Apply flux to all pins of the FLAT PACKAGE IC.

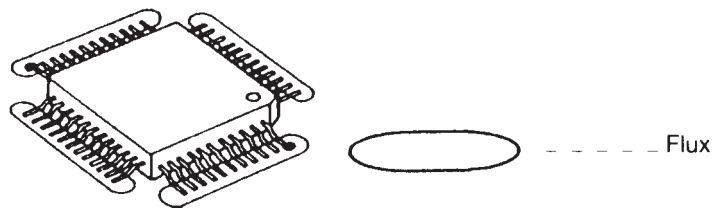

3. Solder the pins, sliding the soldering iron in the direction of the arrow.

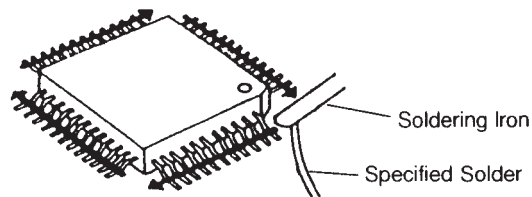

13.2.4. How to Remove a Solder Bridge

1. Lightly resolder the bridged portion.
2. Remove the remaining solder along the pins using a soldering iron as shown in the figure below.

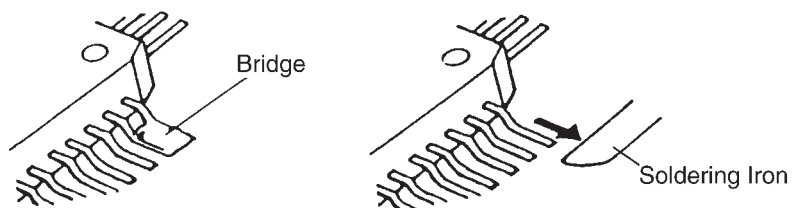

13.3. How to Replace the Shield Case

13.3.1. Preparation

- PbF (: Pb free) Solder
- Soldering Iron
Tip Temperature of 700°F ± 20°F (370°C ± 10°C)

Note:

We recommend a 30 to 40 Watt soldering iron. An expert may be able to use a 60 to 80 Watt iron where someone with less experience could overheat and damage the PCB foil.

- Hot Air Desoldering Tool
Temperature: 608°F ± 68°F (320°C ± 20°C)

13.3.2. Caution

- To replace the IC efficiently, choose the right sized nozzle of the hot air desoldering tool that matches the IC package.
- Be careful about the temperature of the hot air desoldering tool not to damage the PCB and/or IC.

13.3.3. How to Remove the Shield Case

Note:

If you don't have special tools (ex. Hot air disordering tool), conduct the following operations.

1. Cut the case along perforation.

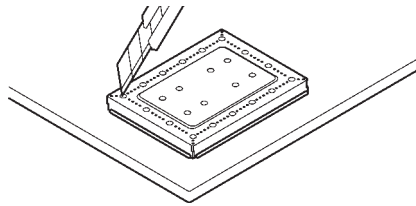

2. Remove the cut part.

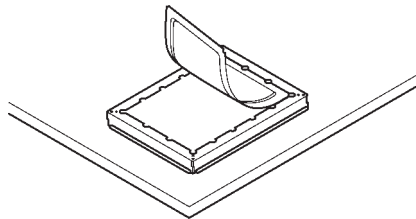

3. Cut the four corners along perforation.

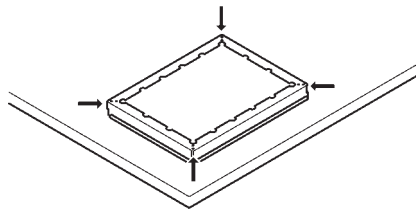

4. Remove the remains by melting solder.

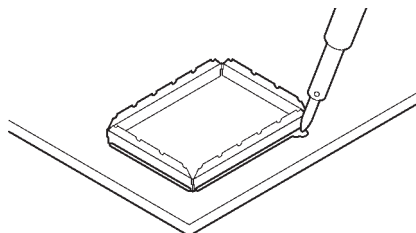

13.3.4. How to Install the Shield Case

Note:

- If you don't have special tools (ex. Hot air disordering tool), conduct the following operations.
- Shield case's No. : PNMC1018Z

1. Put the shield case.

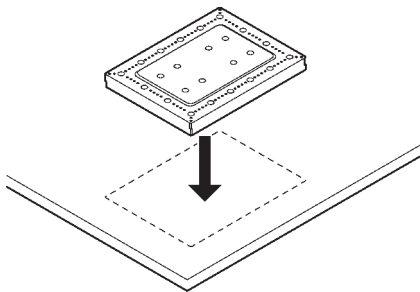



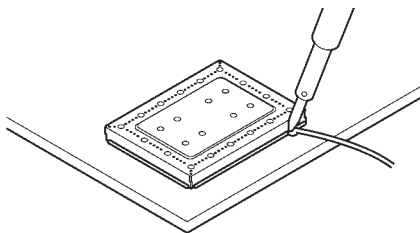



2. Solder the surroundings.

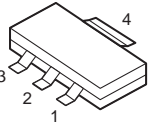
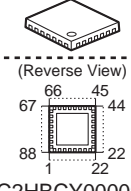
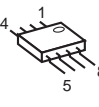
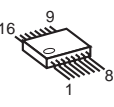
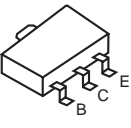
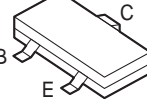
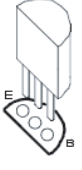

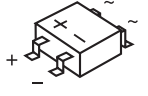
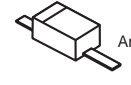

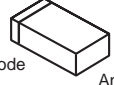
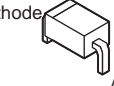
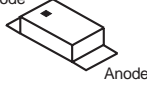

13.4. Terminal Guide of the ICs, Transistors and Diodes

13.4.1. Base Unit

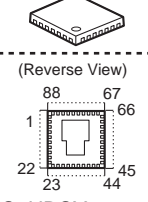
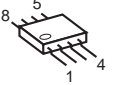
 <p>C0DBEYY00102</p>	 <p>(Reverse View) C2HBCY000094</p>	 <p>PNWI2TG6671H PNWI1TG6671H C1CB00002903</p>	 <p>C0JBAQ000247</p>	 <p>DSC7003S0L</p>
 <p>B1ABDF000017, B1GBCFY0020, B1ADGJ000002 B1ABDM000001, 2SA1037K, B1GDCFNN0001, PQVTBF822T7 B1ADCF000040, B1ADNB000003, B0DDCD000001</p>		 <p>B1ACGP000008</p>	 <p>B1GDCFJJ0001</p>	
 <p>PQVMD5S B0EDER000009</p>	 <p>Cathode Anode 1SS355 B0BC4R7A0268 B0JCMC000006 B0JCDD000001</p>	 <p>PQVDPTZT2530</p>	 <p>Cathode Anode MAZ805100L</p>	 <p>Cathode Anode B0ECKM000008</p>
 <p>Cathode Anode LNJ826W83RA</p>	 <p>Anode Cathode B3AFB0000211</p>			

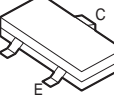
13.4.2. Portable

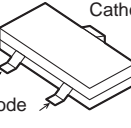
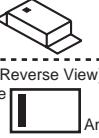
 <p>(Reverse View) C2HBCY000081</p>	 <p>PNWITGA660BR</p>	 <p>C0DBZYY00357</p>	 <p>B1ADCF000040 B1GBCFY0010 B1ABDF000017 B1ADNB000003</p>	 <p>B1ABGE000011</p>
 <p>Cathode Anode MA8043</p>	 <p>Cathode Anode B0DDCD000001</p>	 <p>(Reverse View) Cathode Anode B3ACB0000216</p>		

14 Schematic Diagram

14.1. For Schematic Diagram

14.1.1. Base Unit (Schematic Diagram (Base Unit_Main))

Notes:

1. DC voltage measurements are taken with voltmeter from the negative voltage line.

Important Safety Notice:

Components identified by \triangle mark have special characteristics important for safety. When replacing any of these components, use only the manufacture's specified parts.

2. The schematic diagrams may be modified at any time with the development of new technology.

14.1.2. Portable (Schematic Diagram (Portable_Main))

Notes:

1. DC voltage measurements are taken with an oscilloscope or a tester with a ground.
2. The schematic diagrams may be modified at any time with the development of new technology.

14.1.3. Charger Unit (Schematic Diagram (Charger Unit))

Notes:

1. DC voltage measurements are taken with voltmeter from the negative voltage line.

Important Safety Notice:

Components identified by \triangle mark have special characteristics important for safety. When replacing any of these components, use only the manufacture's specified parts.

2. The schematic diagrams may be modified at any time with the development of new technology.

14.2. Schematic Diagram (Base Unit_Main)

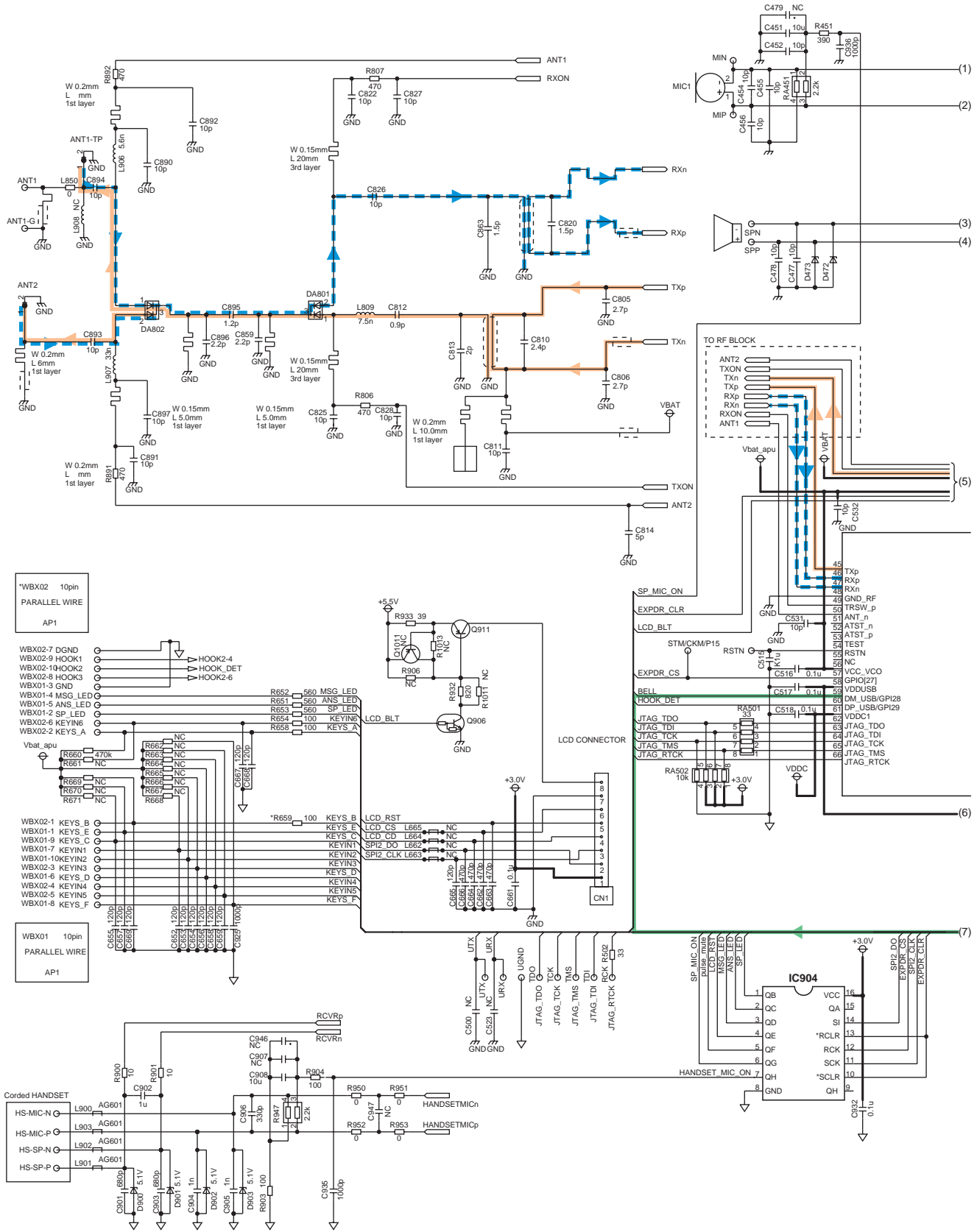

NC: No Components

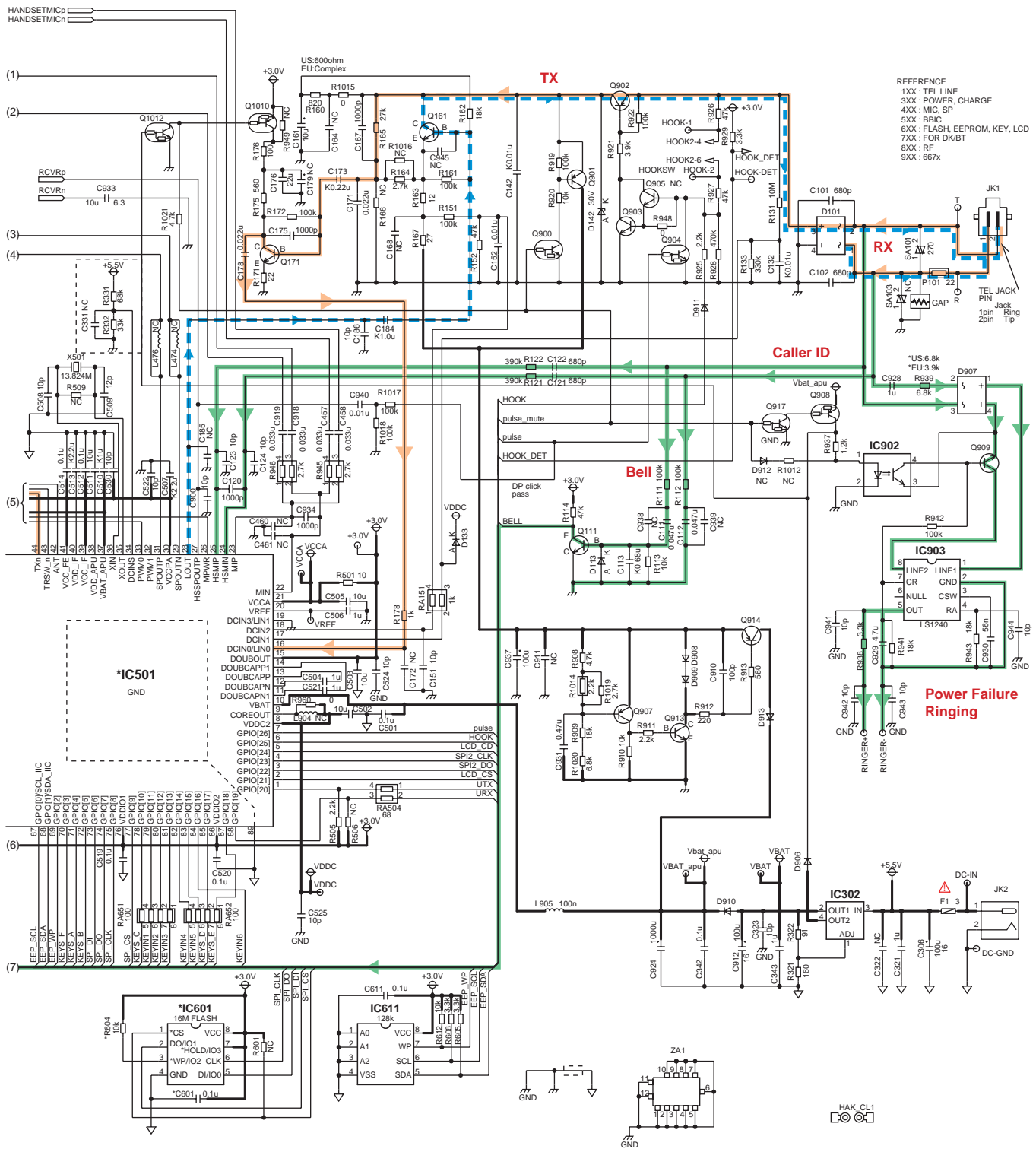

NC: No Components

KX-TG6671/6672 SCHEMATIC DIAGRAM (Base Unit_Main)

14.3. Schematic Diagram (Base Unit_Operation)

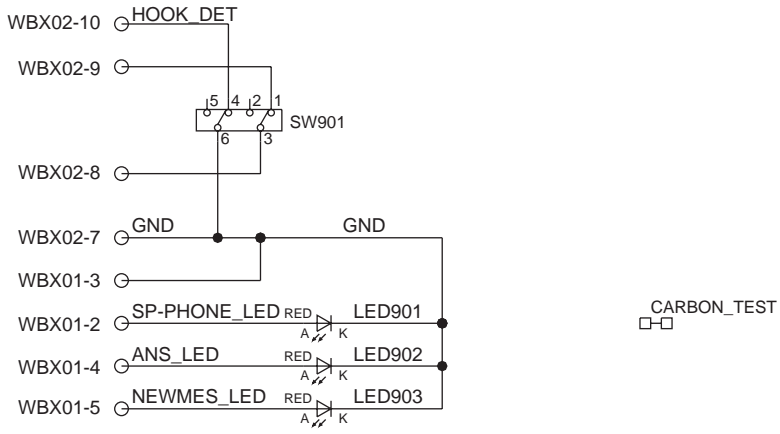
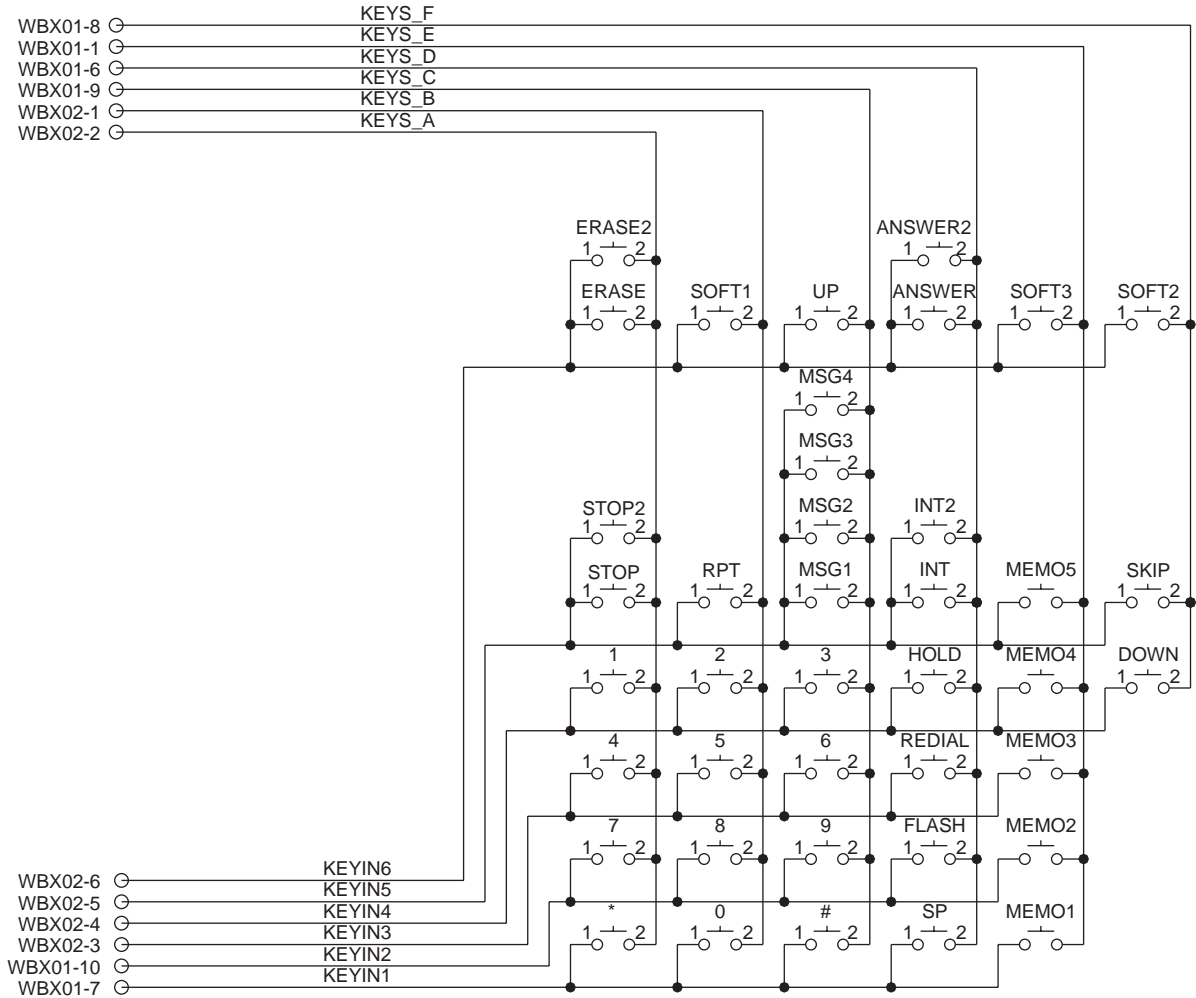

NC: No Components

KX-TG6671/6672 SCHEMATIC DIAGRAM (Base Unit_Operation)

14.4. Schematic Diagram (Base Unit_LCD)

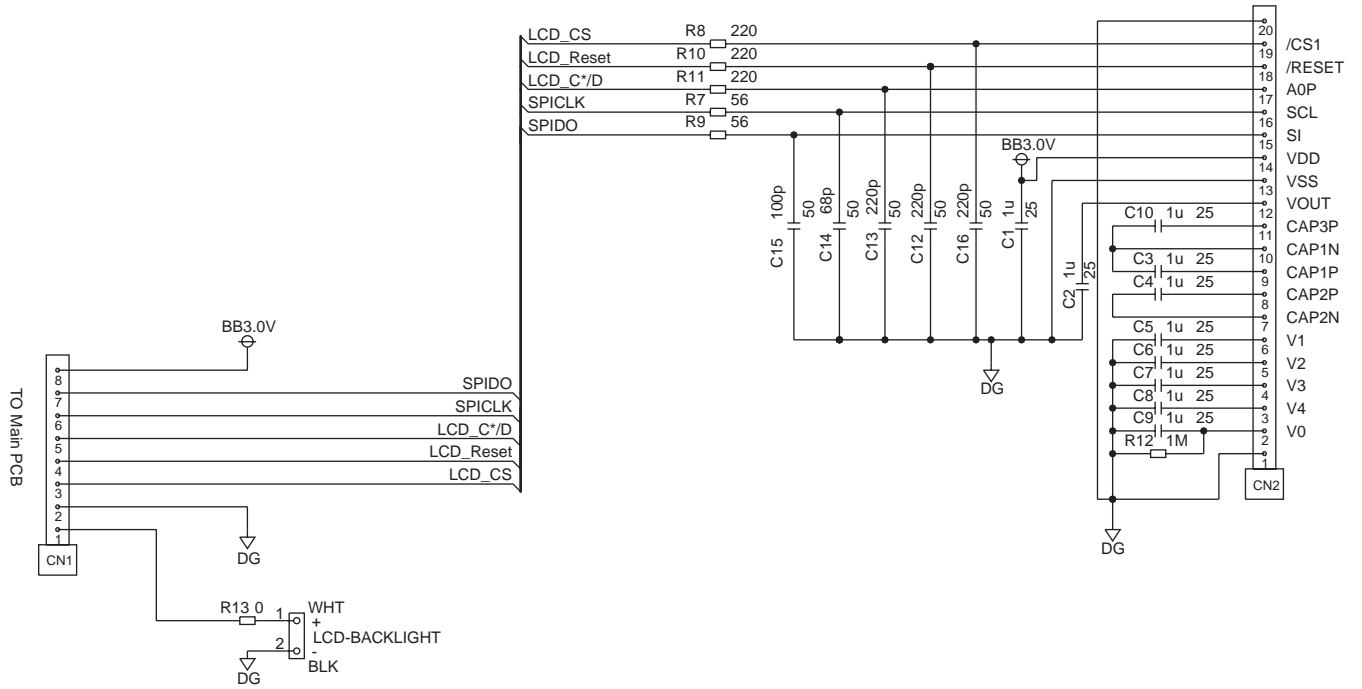

NC: No Components

KX-TG6671/6672 SCHEMATIC DIAGRAM (Base Unit_LCD)

14.5. Schematic Diagram (Base Unit_LED)

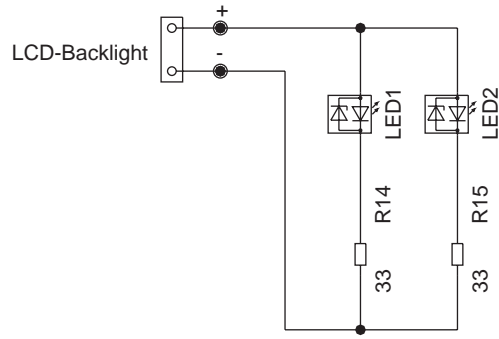

NC: No Components

KX-TG6671/6672 SCHEMATIC DIAGRAM (Base Unit_LED)

Memo

14.6. Schematic Diagram (Portable_Main)

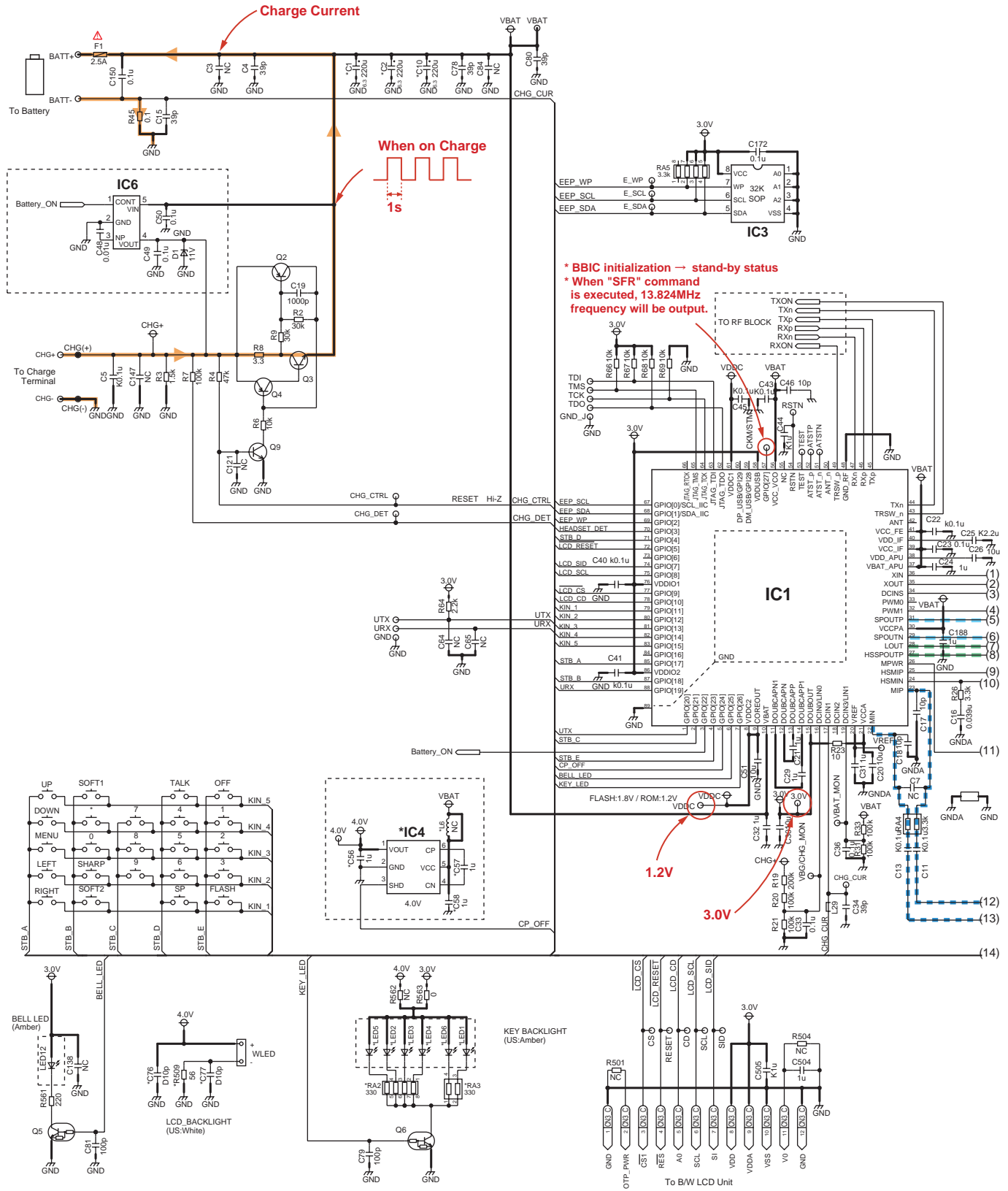

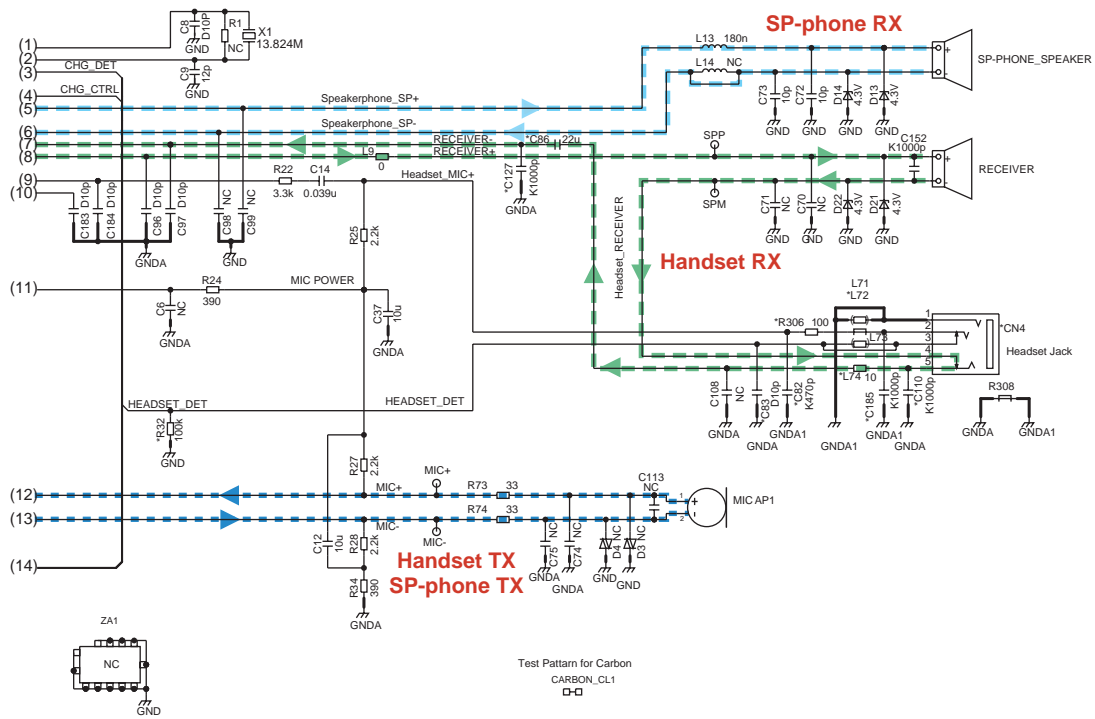
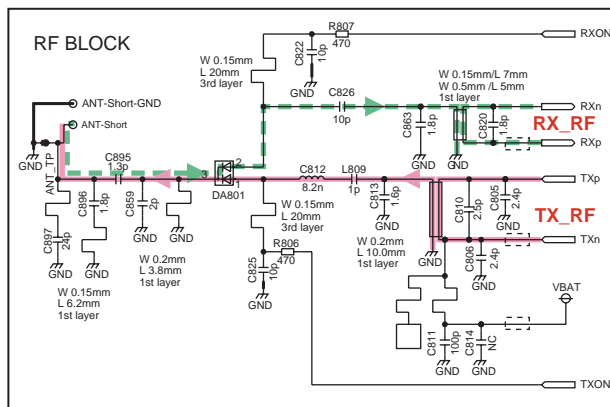

14.7. Schematic Diagram (Portable_LED)

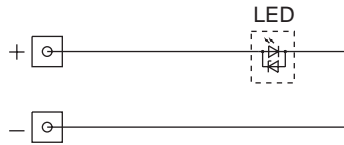

KX-TGA660 SCHEMATIC DIAGRAM (Portable_LED)

14.8. Schematic Diagram (Charger Unit)

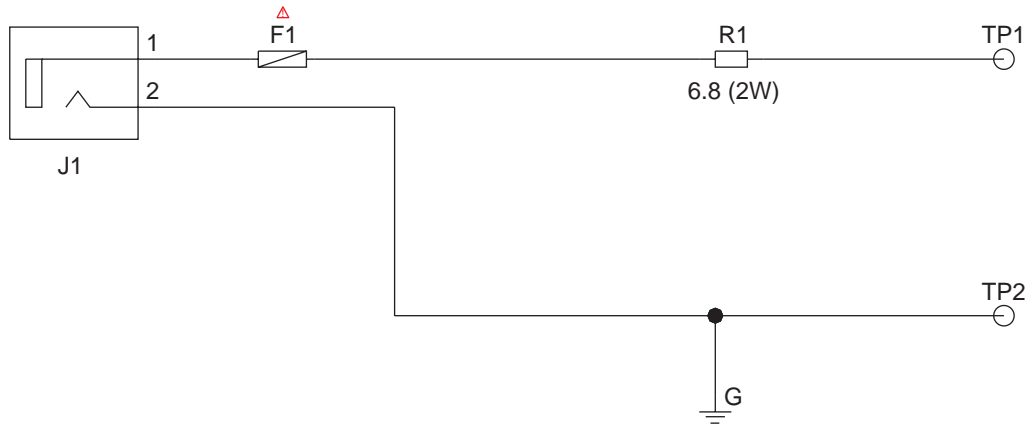

SCHEMATIC DIAGRAM (Charger Unit)

Memo

15.2. Circuit Board (Base Unit_Operation)

15.2.1. Component View

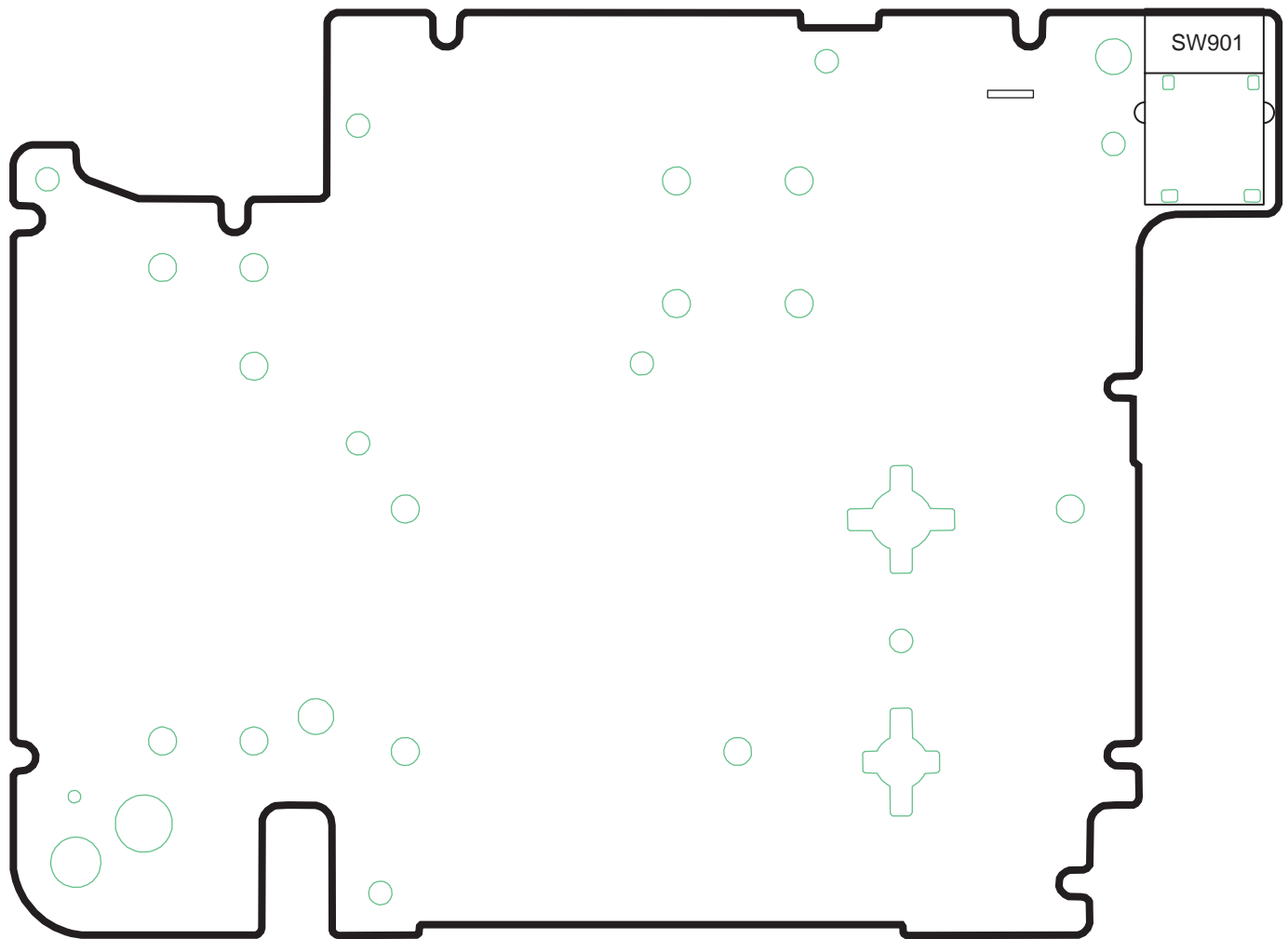

KX-TG6671/6672 CIRCUIT BOARD (Base Unit_Operation (Component View))

15.2.2. Bottom View

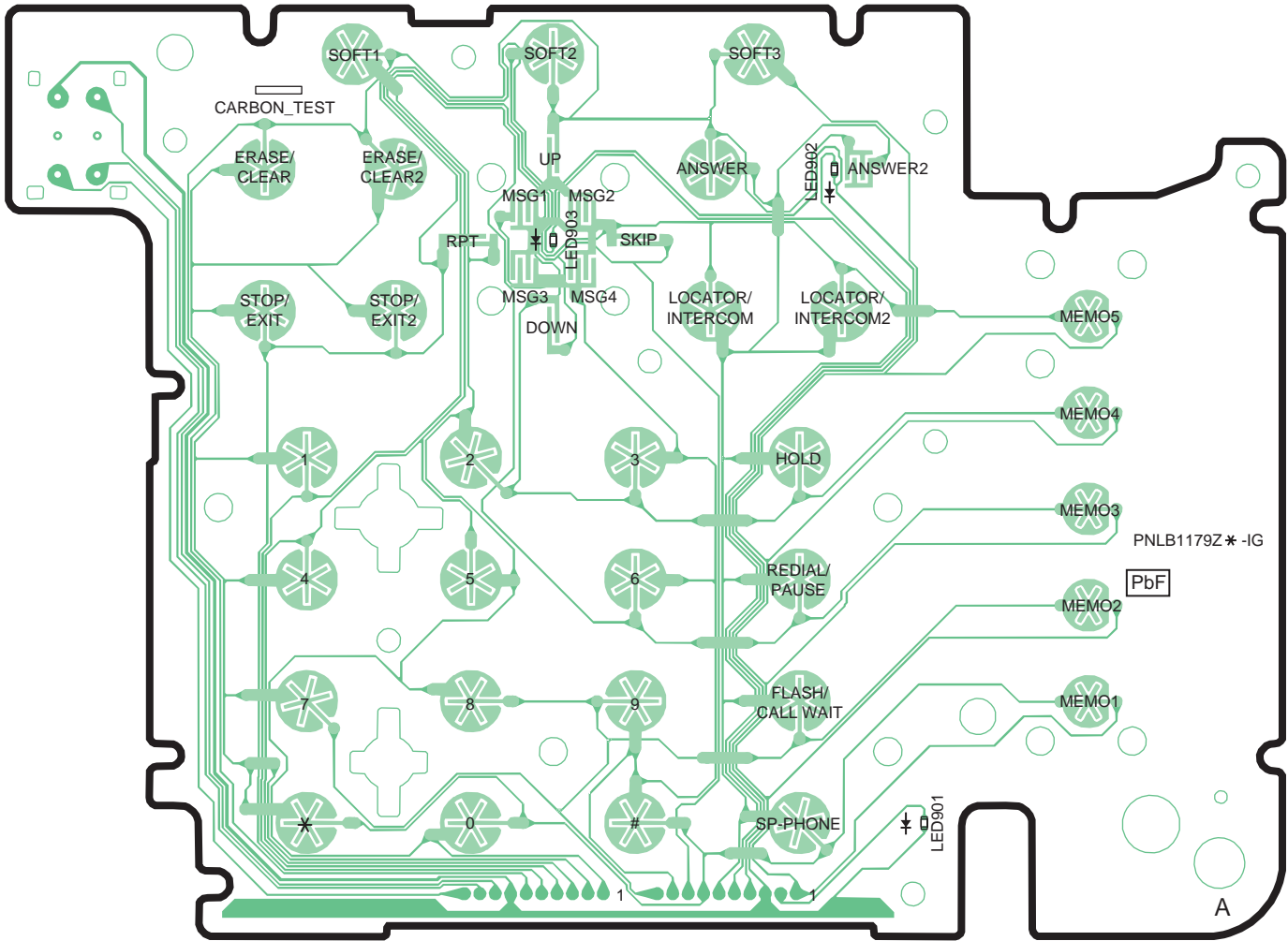

KX-TG6671/6672 CIRCUIT BOARD (Base Unit_Operation (Bottom View))

15.3. Circuit Board (Base Unit_LCD)

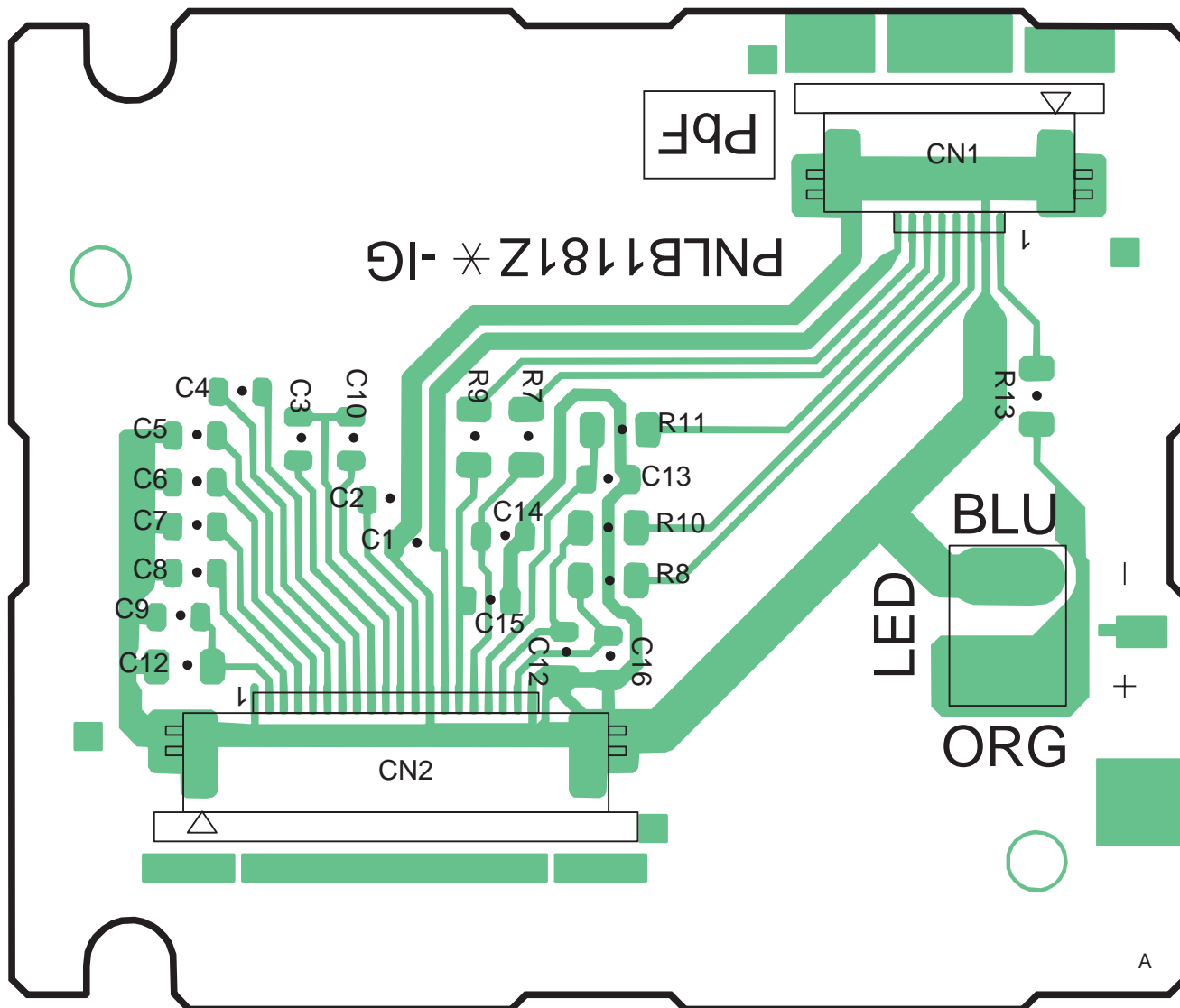

KX-TG6671/6672 CIRCUIT BOARD (Base Unit_LCD (Component View))

15.4. Circuit Board (Base Unit_LED)

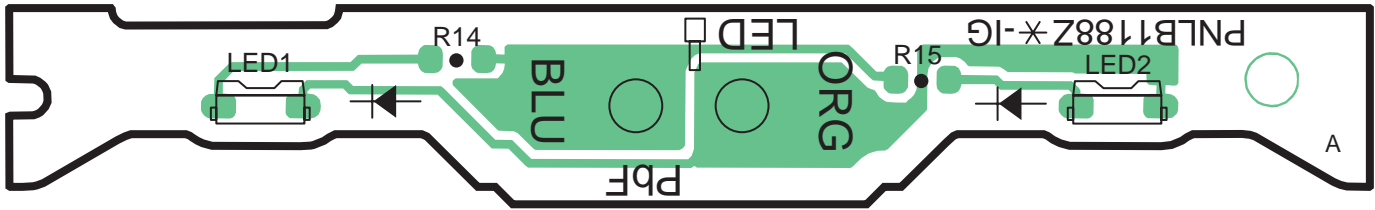

KX-TG6671/6672 CIRCUIT BOARD (Base Unit_LED (Component View))

15.5. Circuit Board (Portable_Main)

15.5.1. Component View

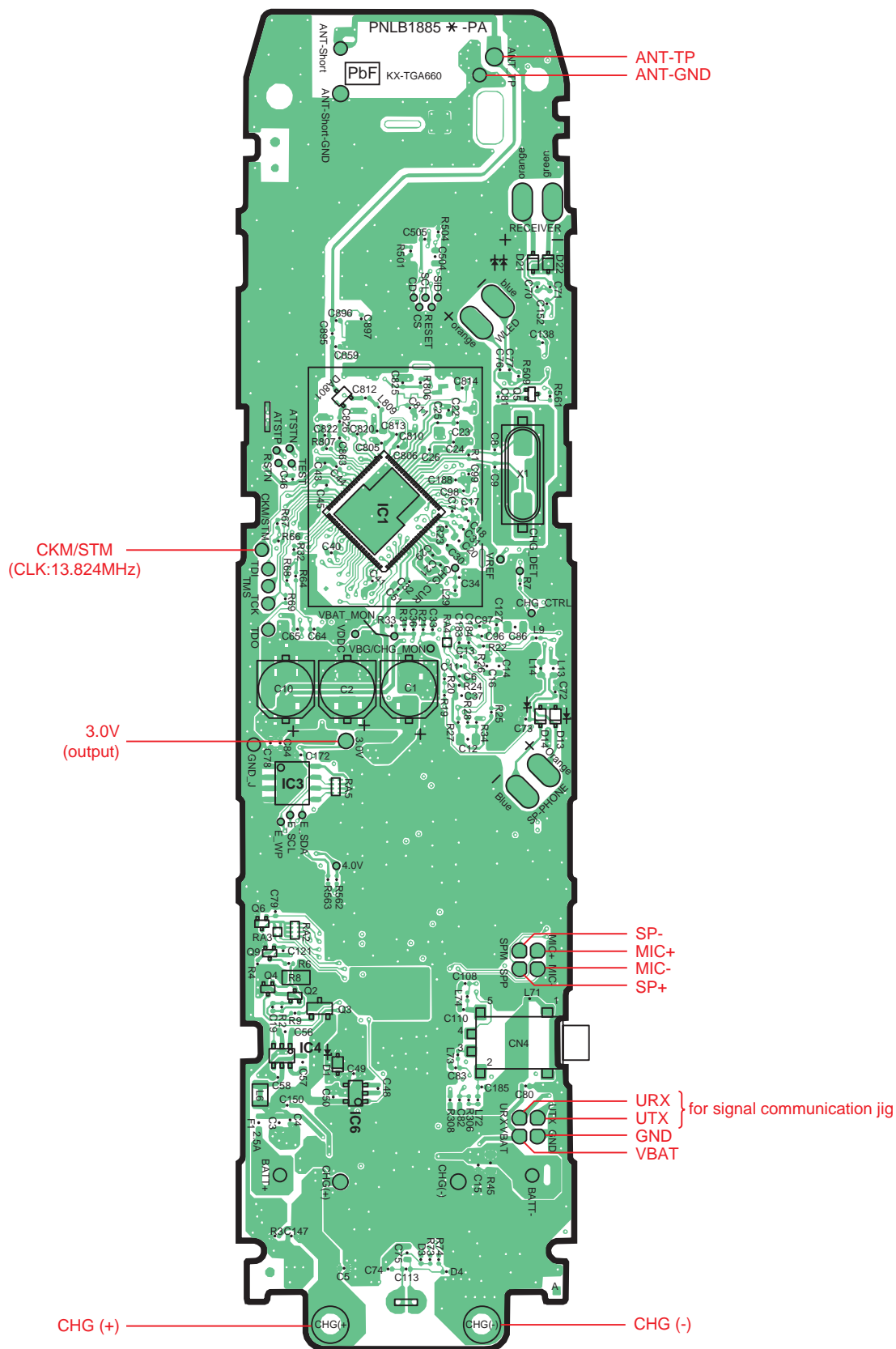

KX-TGA660 CIRCUIT BOARD (Portable_Main (Component View))

15.5.2. Bottom View

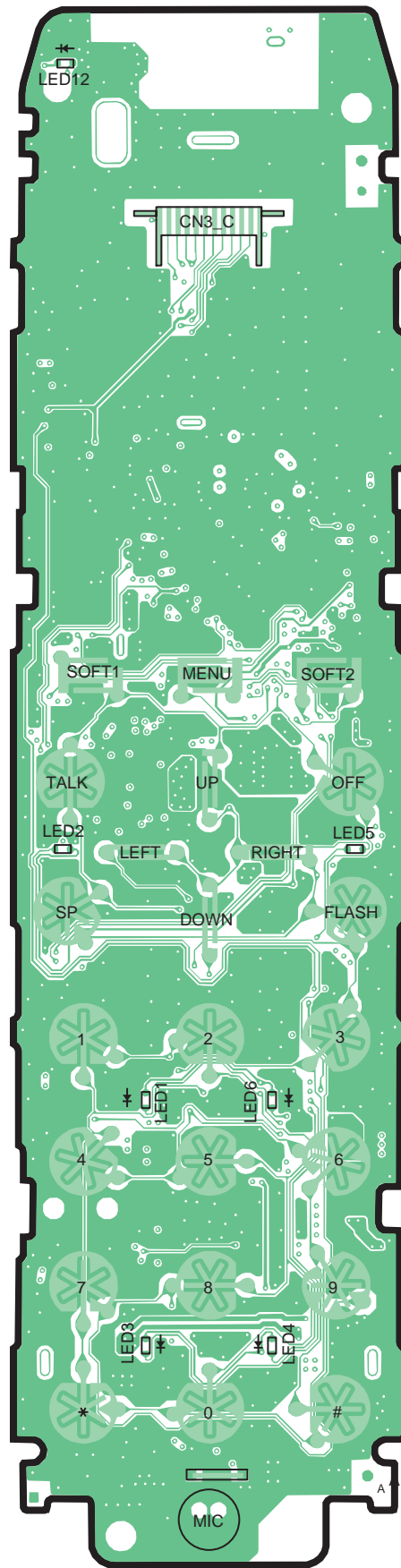

KX-TGA660 CIRCUIT BOARD (Portable_Main (Bottom View))

15.6. Circuit Board (Portable_LED)



KX-TGA660 CIRCUIT BOARD (Portable_LED (Component View))

15.7. Circuit Board (Charger Unit)

15.7.1. Component View

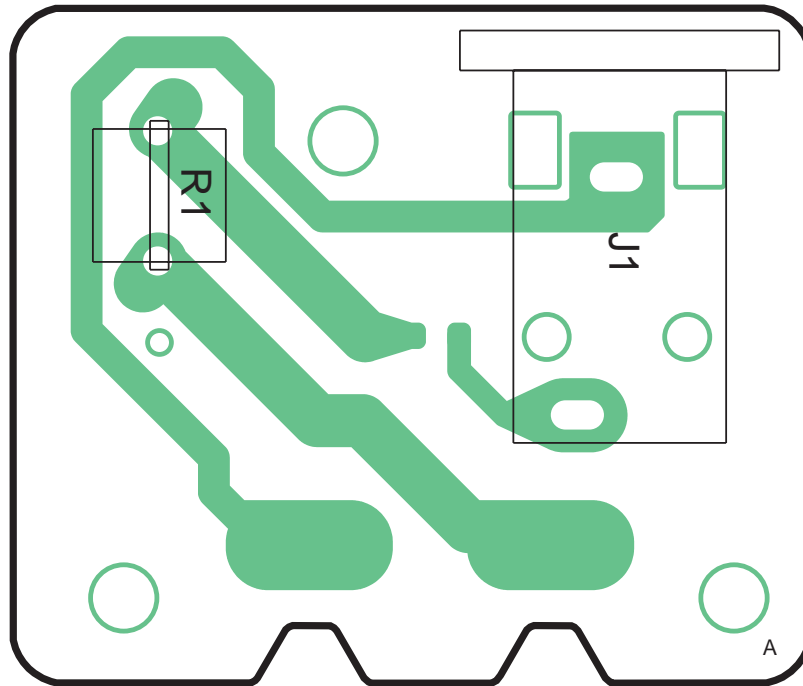

CIRCUIT BOARD (Charger Unit (Component View))

15.7.2. Bottom View

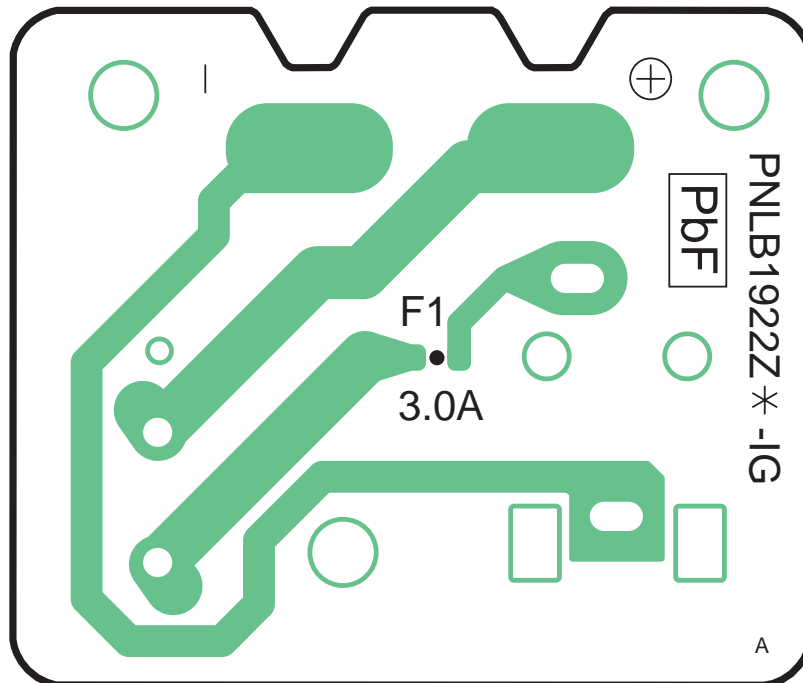

CIRCUIT BOARD (Charger Unit (Bottom View))

16 Exploded View and Replacement Parts List

16.1. Cabinet and Electrical Parts (Base Unit)

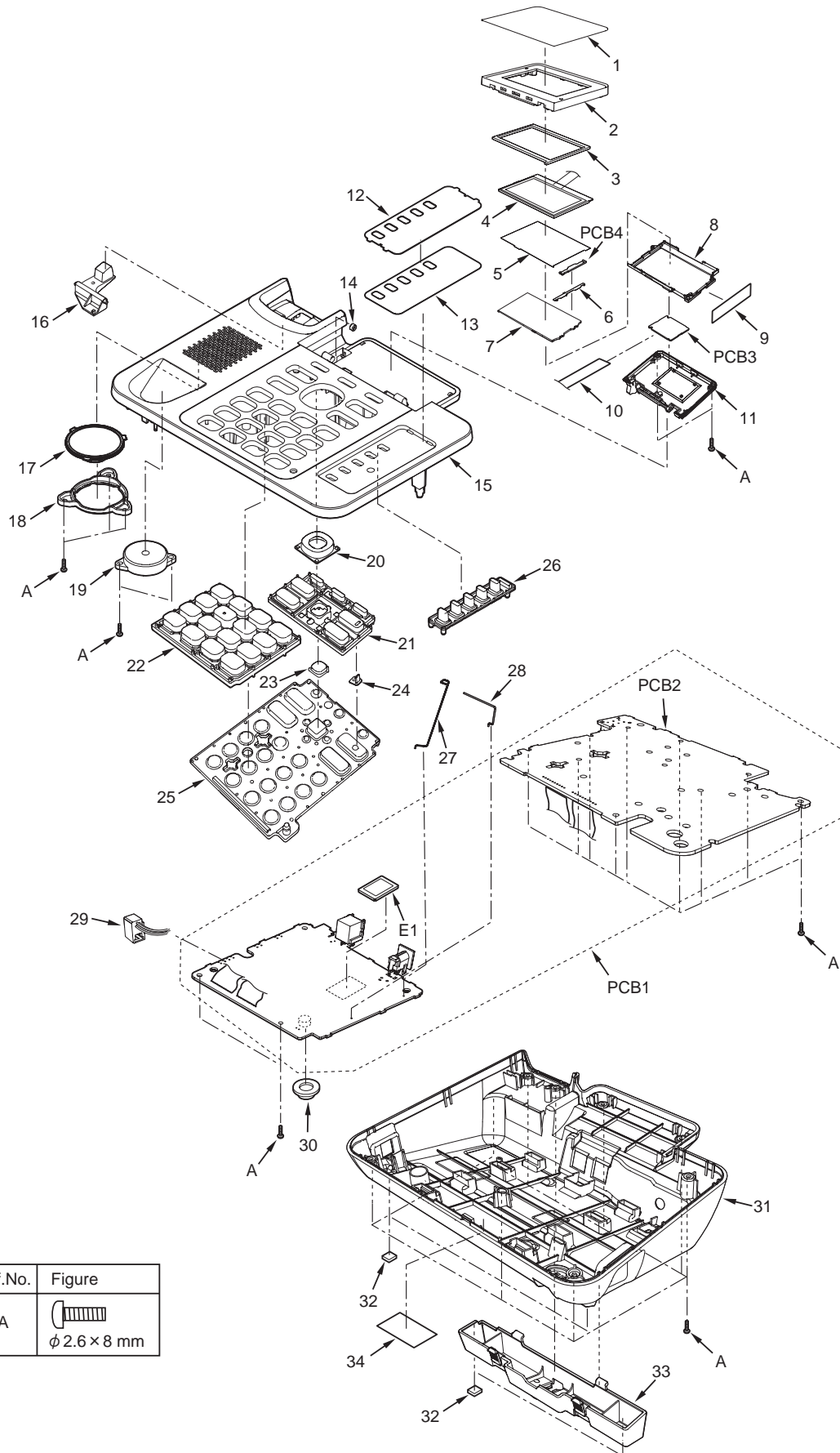

16.2. Cabinet and Electrical Parts (Portable)

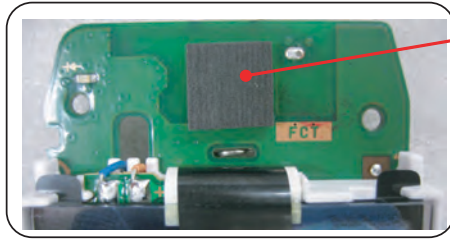

CUSHION RUBBER
*STICK IT WITHIN THE FRAMEWORK ON P.C.B.

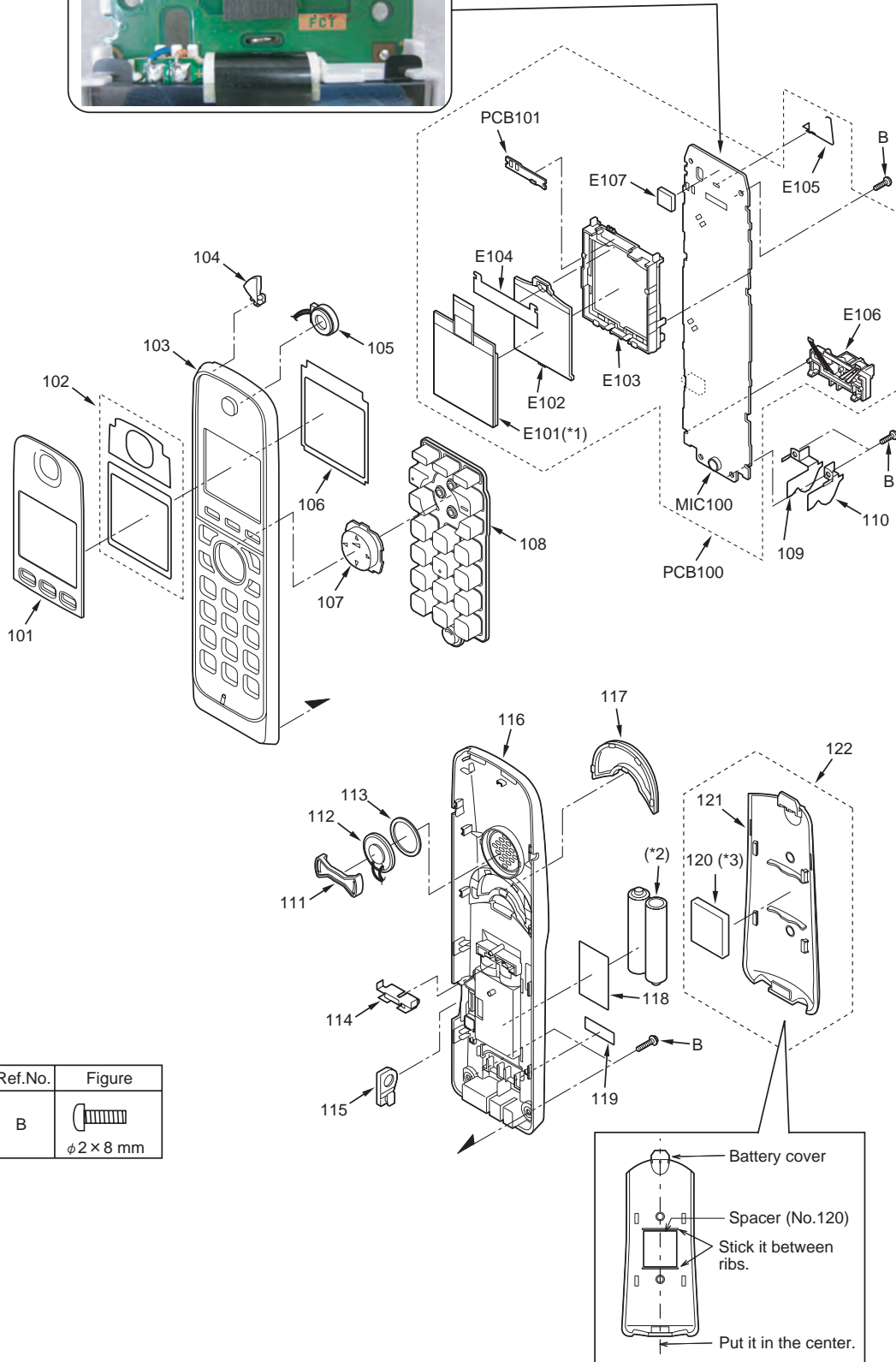

Note:

(*1) This cable is fixed by welding. Refer to **How to Replace the Portable LCD (P.51)**.

(*2) The rechargeable Ni-MH battery HHR-4DPA is available through sales route of Panasonic.

(*3) Attach the SPACER (No. 120) to the exact location described above.

16.3. Cabinet and Electrical Parts (Charger Unit)

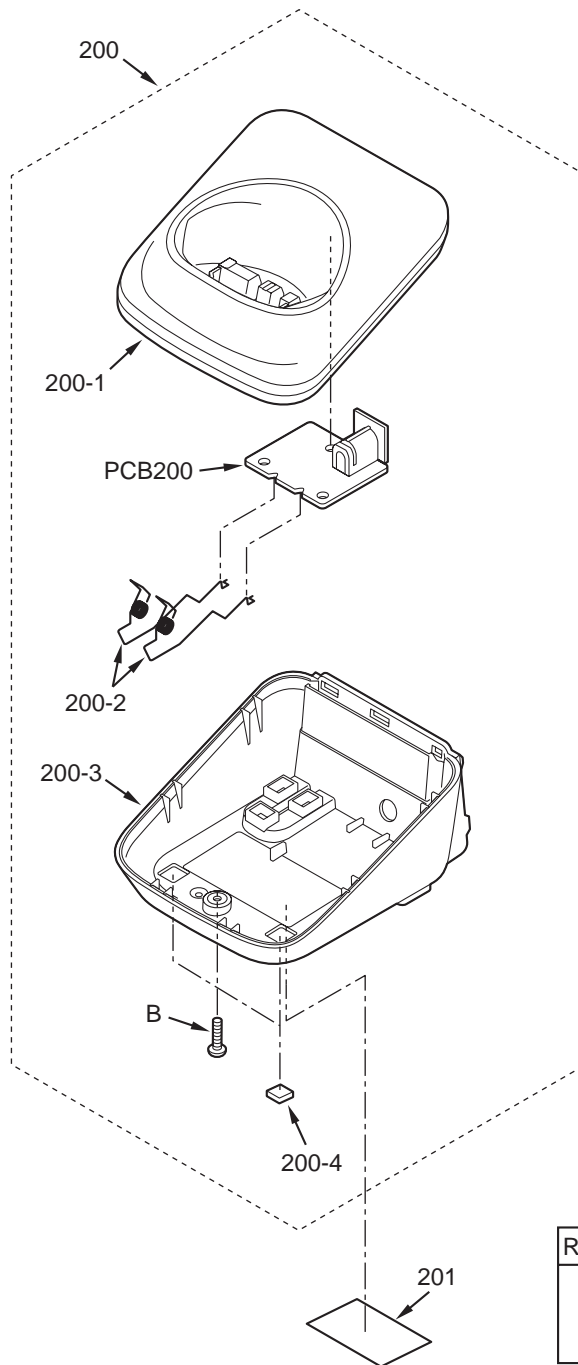

Ref.No.	Figure
B	 $\phi 2 \times 8 \text{ mm}$

16.4. Accessories and Packing Materials

16.4.1. KX-TG6671B

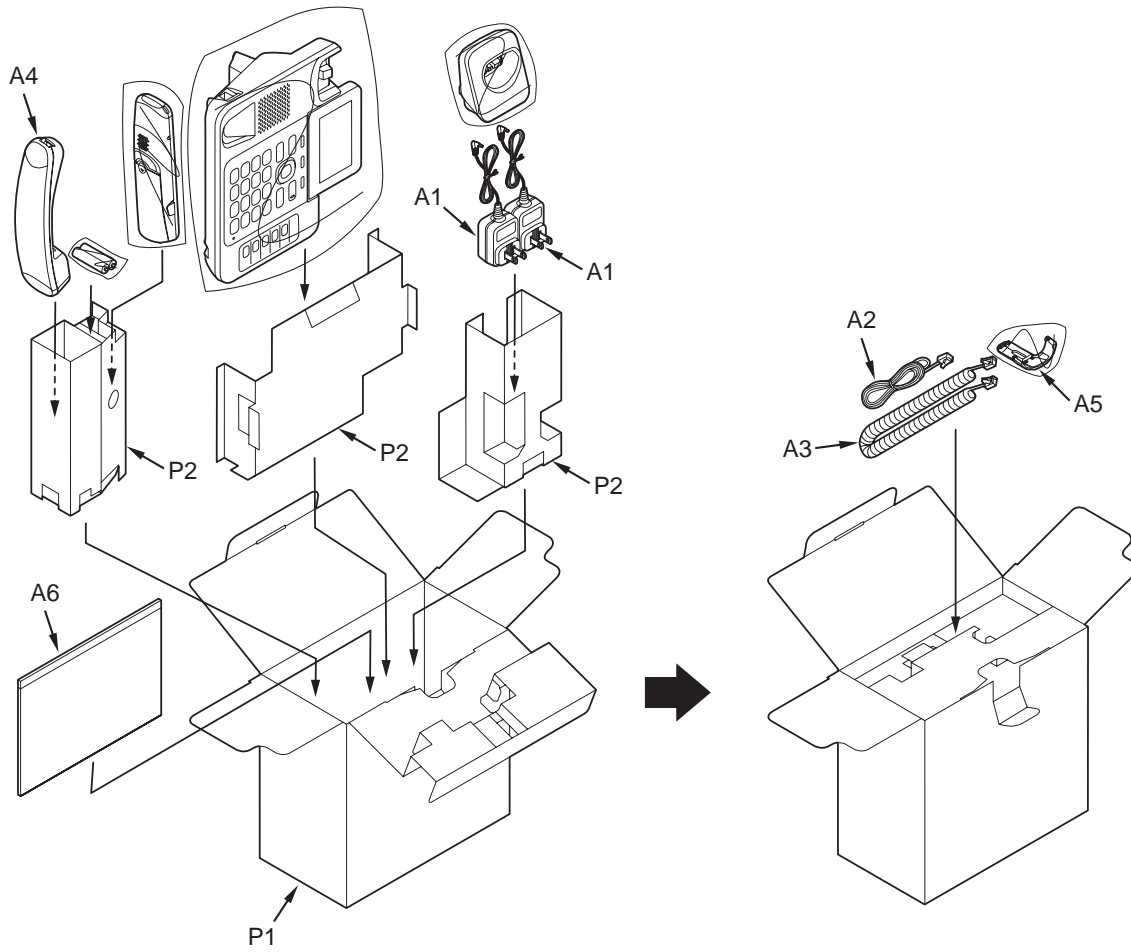

16.4.2. KX-TG6672B

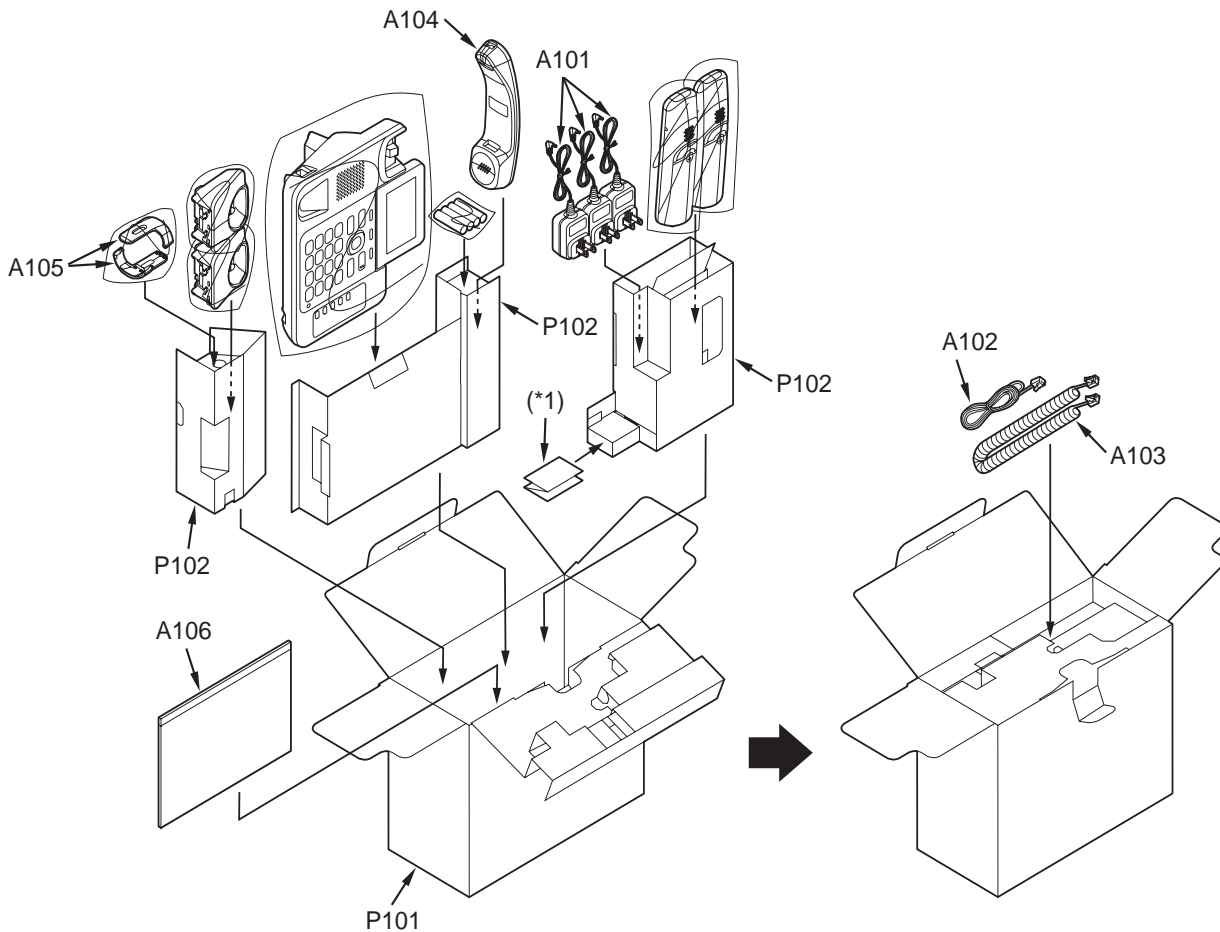

Note:

(*1)This pad is a piece of Ref No.P101 (GIFT BOX).

16.4.3. KX-TGA660B

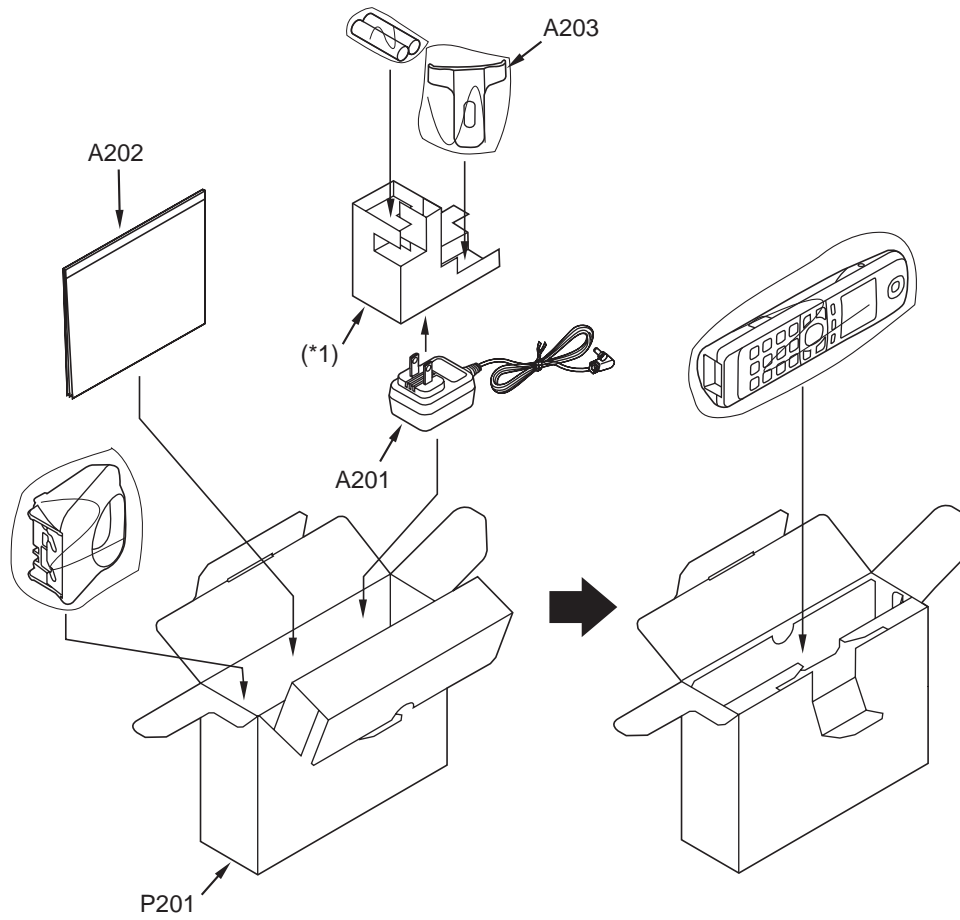

Note:
(*1) This pad is a piece of Ref No. P401 (GIFT BOX).

16.5. Replacement Parts List

1. RTL (Retention Time Limited)

Note:

The "RTL" marking indicates that its Retention Time is Limited.

When production is discontinued, this item will continue to be available only for a specific period of time.

This period of time depends on the type of item, and the local laws governing parts and product retention. At the end of this period, the item will no longer be available.

2. Important safety notice

Components identified by the Δ mark indicates special characteristics important for safety. When replacing any of these components, only use specified manufacturer's parts.

3. The S mark means the part is one of some identical parts.

For that reason, it may be different from the installed part.

4. ISO code (Example: ABS-94HB) of the remarks column shows quality of the material and a flame resisting grade about plastics.

5. RESISTORS & CAPACITORS

Unless otherwise specified;

All resistors are in ohms (Ω) k=1000 Ω , M=1000k Ω

All capacitors are in MICRO FARADS (μ F) p= μ F

*Type & Wattage of Resistor

Type

ERC:Solid ERDS:Carbon ERJ:Chip	ERX:Metal Film ERG:Metal Oxide ER0:Metal Film	PQ4R:Chip ERS:Fusible Resistor ERF:Cement Resistor
--------------------------------------	---	--

Wattage

10,16:1/8W	14,25:1/4W	12:1/2W	1:1W	2:2W	3:3W
------------	------------	---------	------	------	------

*Type & Voltage Of Capacitor

Type

ECFD:Semi-Conductor ECQS:Styrol ECUV,PQCUV, ECUE:Chip ECQMS:Mica	ECCD,ECKD,ECBT,F1K,ECUV: Ceramic ECQE,ECQV,ECQG:Polyester ECEA,ECST,EEE:Electlytic ECQP:Polypropylene
---	--

Voltage

ECQ Type	ECQG ECQV Type	ECSZ Type	Others		
1H:50V 2A:100V 2E:250V 2H:500V	05:50V 1:100V 2:200V	0F:3.15V 1A:10V 1V:35V 0J:6.3V	0J :6.3V 1A :10V 1C :16V 1E,25:25V	1V :35V 50,1H:50V 1J :16V 2A :100V	

16.5.1. Base Unit

16.5.1.1. Cabinet and Electrical Parts

Safety	Ref. No.	Part No.	Part Name & Description	Remarks
	1	PNGP1199Z2	PANEL, LCD	
	2	PNGG1313Y2	GRILLE, LCD	PS-HB
	3	PNYE1055Z	SPACER, CUSHION LCD	
	4	L5DYBYY00034	LIQUID CRYSTAL DISPLAY	
	5	PNHX1466Z	COVER, DIFFUSION SHEET	
	6	PNHX1465Z	COVER, REFLECTOR SHEET	
	7	PNHR1528Z	LCD PLATE	PMMA-HB
	8	PNHR1527Z	GUIDE, LCD	ABS-HB
	9	PNHX1502Z	COVER, LCD SHEET	
	10	PNJE1121Z	LEAD WIRE, FFC	
	11	PNKV1136Z1	COVER, LCD	ABS-HB
	12	PNGV1016Z	COVER, TEL CARD	
	13	PNGD1059Z	TEL CARD	

Safety	Ref. No.	Part No.	Part Name & Description	Remarks
	14	6SA522A	RUBBER PARTS, RING	
	15	PNKM1234Z1	UPPER CABINET	PS-HB
	16	PNBH1016Z1	HOOK LEVER	ABS-HB
	17	LOAA04A00028	SPEAKER	
	18	PQHR11082Z	GUIDE, SPEAKER	POM-HB
	19	LODDYD000010	BUZZER	
	20	PNBC1404Z2	BUTTON, NAVIGATOR KEY	ABS-HB
	21	PNBX1291Z2	BUTTON, 7 KEY	ABS-HB
	22	PNBX1292Z1	BUTTON, DIAL KEY	ABS-HB
	23	PNBC1345Z1	BUTTON, MESSAGE	PMMA-HB
	24	PNHR1533Z	OPTIC CONDUCTIVE PARTS, ANSWER ON LED LENS	PS-HB
	25	PNJK1137Z	KEYBOARD SWITCH, DIAL	
	26	PNJK1139Z	KEYBOARD SWITCH, DIRECT	
	27	PNLA1072Z	ANTENNA	
	28	PNLA1073Z	ANTENNA	
	29	PQJJ1T030T	JACK, SOCKET	
	30	PQMG10025W	RUBBER PARTS, MIC	
	31	PNKF1172Y1	CABINET COVER	PS-HB
	32	PNHA1013Z	RUBBER PARTS, FOOT CUSHION	
	33	PNKL1034Z1	STAND, WALL MOUNT	ABS-HB
	34	PNGT6139Z	NAME PLATE	

16.5.1.2. Main P.C. Board Parts

Note:

(*1) When replacing IC611 or X501, make the adjustment using PNZZTG6671B. Refer to **How to download the data** (P.59) of Things to Do after Replacing IC or X'tal.

(*2) When removing E1, use special tools (ex. Hot air disordering tool).

Safety	Ref. No.	Part No.	Part Name & Description	Remarks
	PCB1	PNWP1TG6671H	MAIN P.C.BOARD ASS'Y (RTL) (ICs)	
	IC302	C0DBEYY00102	IC	
	IC501	C2HBCY000094	IC	
	IC601	PNWI2TG6671H	IC	
	IC611	PNWI1TG6671H	IC (*1)	
	IC903	C1CB00002903	IC	
	IC904	C0JBAQ000247	IC	
			(TRANSISTORS)	
	Q111	B1ABDF000017	TRANSISTOR(SI)	
	Q161	DSC7003S0L	TRANSISTOR(SI)	
	Q171	B1ABDF000017	TRANSISTOR(SI)	
	Q900	B1GBCFY00020	TRANSISTOR(SI)	
	Q901	B1ADGJ000002	TRANSISTOR(SI)	
	Q902	B1ACGP000008	TRANSISTOR(SI)	
	Q903	B1ABDM000001	TRANSISTOR(SI)	
	Q904	B1GBCFY00020	TRANSISTOR(SI)	
	Q906	B1GBCFY00020	TRANSISTOR(SI)	
	Q907	2SA1037K	TRANSISTOR(SI)	S
	Q908	B1GDGCFN0001	TRANSISTOR(SI)	
	Q909	PQVTBF822T7	TRANSISTOR(SI)	
	Q911	B1ADCF000040	TRANSISTOR(SI)	
	Q913	DSC7003S0L	TRANSISTOR(SI)	
	Q914	B1ADNB000003	TRANSISTOR(SI)	
	Q917	B1GBCFY00020	TRANSISTOR(SI)	
	Q1010	B1GDGCFJ00001	TRANSISTOR(SI)	
	Q1012	B1GBCFY00020	TRANSISTOR(SI)	
			(DIODES)	
	D101	PQVDM5S	DIODE(SI)	
	D113	1SS355	DIODE(SI)	S
	D133	1SS355	DIODE(SI)	S
	D142	PQVDPZT2530	DIODE(SI)	S
	D472	B0BC4R7A0268	DIODE(SI)	
	D473	B0BC4R7A0268	DIODE(SI)	
	D900	MAZ805100L	DIODE(SI)	S
	D901	MAZ805100L	DIODE(SI)	S
	D902	MAZ805100L	DIODE(SI)	S

Safety	Ref. No.	Part No.	Part Name & Description	Remarks
	D903	MAZ805100L	DIODE(SI)	S
	D906	1SS355	DIODE(SI)	S
	D907	B0EDER000009	DIODE(SI)	
	D908	B0ECKM000008	DIODE(SI)	
	D909	B0ECKM000008	DIODE(SI)	
	D910	B0JCMC000006	DIODE(SI)	
	D911	1SS355	DIODE(SI)	S
	D913	B0JCDD000001	DIODE(SI)	
	DA801	B0DDCD000001	DIODE(SI)	
	DA802	B0DDCD000001	DIODE(SI)	
			(JACKS)	
	JK1	K2LB102B0053	JACK, MODULAR	
	JK2	K2ECYB000001	JACK, DC	
			(COILS)	
	L809	G1C7N5JA0044	COIL	
	L900	PQLQR2KA20T	COIL	S
	L901	PQLQR2KA20T	COIL	S
	L902	PQLQR2KA20T	COIL	S
	L903	PQLQR2KA20T	COIL	S
	L905	G1CR10J00010	COIL	
	L906	G1C5N6Z00007	COIL	
	L907	G1C33NJ00009	COIL	
			(COMPONENTS PARTS)	
	R945	D1H427220001	COMPONENTS PARTS	
	R946	D1H427220001	COMPONENTS PARTS	
	R947	D1H422220001	COMPONENTS PARTS	
			(RESISTOR ARRAYS)	
	RA151	D1H410220001	RESISTOR ARRAY	
	RA451	D1H422220001	RESISTOR ARRAY	
	RA501	EXB28V330	RESISTOR ARRAY	
	RA502	EXB28V103	RESISTOR ARRAY	
	RA504	D1H468020001	RESISTOR ARRAY	
	RA651	EXB28V101JX	RESISTOR ARRAY	
	RA652	EXB28V101JX	RESISTOR ARRAY	
			(VARISTOR)	
	SA101	J0LE00000047	VARISTOR (SURGE ABSORBER)	
			(RESISTORS)	
	R111	PQ4R10XJ104	100k	S
	R112	PQ4R10XJ104	100k	S
	R113	ERJ3GEYJ103	10k	S
	R114	ERJ3GEYJ473	47k	S
	R121	ERJ3GEYJ394	390k	S
	R122	ERJ3GEYJ394	390k	S
	R131	PQ4R18XJ106	10M	S
	R133	ERJ3GEYJ334	330k	S
	R151	ERJ2GEJ104	100k	S
	R152	ERJ2GEJ473	47k	S
	R160	ERJ3GEYJ821	820	S
	R161	ERJ3GEYJ104	100k	S
	R162	ERJ3GEYJ183	18k	S
	R163	ERJ12YJ120	12	
	R164	ERJ3GEYJ272	2.7k	S
	R165	ERJ3GEYJ273	27k	S
	R167	ERJ12YJ270	27	
	R171	ERJ2GEJ220	22	S
	R172	ERJ2GEJ104	100k	S
	R175	ERJ2GEJ561	560	S
	R176	ERJ2GEJ101	100	S
	R178	ERJ2GEJ102	1k	S
	R321	ERJ2RKF161X	160	
	R322	ERJ2RKF910X	91	
	R331	ERJ3EKF6802	68k	
	R332	ERJ3EKF3302	33k	
	R451	ERJ2GEJ391	390	S
	R501	ERJ3GEYJ100	10	S
	R502	ERJ2GEJ330	33	S
	R505	ERJ2GEJ222	2.2k	S
	R604	ERJ2GEJ103	10k	S
	R605	ERJ2GEJ332	3.3k	S
	R606	ERJ2GEJ332	3.3k	S
	R612	ERJ2GEJ103	10k	S
	R651	ERJ2GEJ561	560	S

Safety	Ref. No.	Part No.	Part Name & Description	Remarks
	R652	ERJ2GEJ561	560	S
	R653	ERJ2GEJ561	560	S
	R654	ERJ2GEJ101	100	S
	R658	ERJ2GEJ101	100	S
	R659	ERJ2GEJ101	100	S
	R660	ERJ2GEJ474X	470k	S
	R806	ERJ2GEJ471	470	S
	R807	ERJ2GEJ471	470	S
	R891	ERJ2GEJ471	470	S
	R892	ERJ2GEJ471	470	S
	R900	ERJ2GEJ100	10	S
	R901	ERJ2GEJ100	10	S
	R903	ERJ2GEJ101	100	S
	R904	ERJ2GEJ101	100	S
	R908	ERJ2RKF472X	4.7k	
	R909	ERJ2RKF183X	18k	
	R910	ERJ2GEJ103	10k	S
	R911	ERJ2GEJ222	2.2k	S
	R912	ERJ2GEJ221	220	S
	R913	ERJ2GEJ561	560	S
	R919	ERJ3GEYJ104	100k	S
	R920	ERJ3GEYJ103	10k	S
	R921	PQ4R10XJ392	3.9k	S
	R922	ERJ3GEYJ104	100k	S
	R925	ERJ2GEJ222	2.2k	S
	R926	ERJ3GEYJ473	47k	S
	R927	ERJ3GEYJ473	47k	S
	R928	ERJ3GEYJ474	470k	S
	R929	ERJ2GEJ332	3.3k	S
	R932	ERJ2GEJ821	820	S
	R933	ERJ3GEYJ390	39	S
	R937	ERJ2GEJ122	1.2k	S
	R938	ERJ3GEYJ332	3.3k	S
	R939	ERJ14YJ682	6.8k	
	R941	ERJ3GEYJ183	18k	S
	R942	ERJ3GEYJ104	100k	S
	R943	ERJ3GEYJ183	18k	S
	R948	ERJ2GEOR00	0	S
	R950	ERJ2GEOR00	0	S
	R951	ERJ2GEOR00	0	S
	R952	ERJ2GEOR00	0	S
	R953	ERJ2GEOR00	0	S
	R960	ERJ3GEYOR00	0	S
	R1015	ERJ3GEYOR00	0	S
	R1017	ERJ2GEJ104	100k	S
	R1018	ERJ2GEJ104	100k	S
	R1019	ERJ2GEJ272	2.7k	S
	R1020	ERJ2RKF682X	6.8k	
	R1021	ERJ2GEJ472X	4.7k	S
	L850	ERJ3GEYOR00	0	S
			(CAPACITORS)	
	C101	ECUV2H681KB	680p	S
	C102	ECUV2H681KB	680p	S
	C111	FLJ2A473A024	0.047	
	C112	FLJ2A473A024	0.047	
	C113	PQCUV1A684KB	0.68	
	C120	ECUE1H102KBQ	0.001	
	C121	ECUV2H681KB	680p	S
	C122	ECUV2H681KB	680p	S
	C123	ECUE1H100DCQ	10p	
	C124	ECUE1H100DCQ	10p	
	C132	ECUV1H103KBV	0.01	
	C142	ECUV1H103KBV	0.01	
	C151	ECUE1H100DCQ	10p	
	C152	ECUE1C103KBQ	0.01	
	C161	F2A1H100B132	10	
	C167	ECUV1H102KBV	0.001	
	C171	ECUV1C223KBV	0.022	
	C173	ECUV1A224KBV	0.22	
	C175	ECUE1H102KBQ	0.001	
	C176	FLJ0J2260004	22	
	C178	ECUV1C223KBV	0.022	
	C184	ECUV1A105KBV	1	

Safety	Ref. No.	Part No.	Part Name & Description	Remarks
	C186	ECUE1H100DCQ	10p	
	C306	F2A1C1010119	100	
	C321	ECUV1A105KBV	1	
	C323	ECUE1H100DCQ	10p	S
	C342	ECUV1C104KBV	0.1	
	C343	ECUV1A105KBV	1	
	C451	PQCUV0J106KB	10	
	C452	ECUE1H100DCQ	10p	
	C454	ECUE1H100DCQ	10p	
	C455	ECUE1H100DCQ	10p	
	C456	ECUE1H100DCQ	10p	
	C457	ECUE1C333KBQ	0.033	
	C458	ECUE1C333KBQ	0.033	
	C477	ECUE1H100DCQ	10p	
	C478	ECUE1H100DCQ	10p	
	C501	ECUE1A104KBQ	0.1	
	C502	ECJ1VB0G106M	10	S
	C503	ECJ1VB0G106M	10	S
	C504	ECUE0J105KBQ	1	
	C505	ECJ1VB0G106M	10	S
	C506	ECUV1A105KBV	1	
	C507	ECUV1A225KBV	2.2	
	C508	ECUE1H100DCQ	10p	
	C509	ECUE1H120JCQ	12p	
	C510	ECUV1A105KBV	1	
	C511	ECJ1VB0G106M	10	S
	C512	ECUE1A104KBQ	0.1	
	C513	ECUV1A225KBV	2.2	
	C514	ECUE1A104KBQ	0.1	
	C515	ECUV1A105KBV	1	
	C516	ECUE1A104KBQ	0.1	
	C517	ECUE1A104KBQ	0.1	
	C518	ECUE1A104KBQ	0.1	
	C519	ECUE1A104KBQ	0.1	
	C520	ECUE1A104KBQ	0.1	
	C521	ECUE0J105KBQ	1	
	C522	ECUE1H100DCQ	10p	
	C524	ECUE1H100DCQ	10p	S
	C525	ECUE1H100DCQ	10p	S
	C530	ECUE1H100DCQ	10p	
	C531	ECUE1H100DCQ	10p	
	C532	ECUE1H100DCQ	10p	
	C601	ECUE1A104KBQ	0.1	
	C611	ECUE1A104KBQ	0.1	
	C652	ECUE1H121JCQ	120p	
	C653	ECUE1H121JCQ	120p	
	C654	ECUE1H121JCQ	120p	
	C655	ECUE1H121JCQ	120p	
	C656	ECUE1H121JCQ	120p	
	C657	ECUE1H121JCQ	120p	
	C658	ECUE1H121JCQ	120p	
	C659	ECUE1H121JCQ	120p	
	C661	ECUE1A104KBQ	0.1	
	C662	ECUE1H471KBQ	470p	
	C663	ECUE1H471KBQ	470p	
	C664	ECUE1H471KBQ	470p	
	C665	ECUE1H121JCQ	120p	
	C666	ECUE1H471KBQ	470p	
	C667	ECUE1H121JCQ	120p	
	C668	ECUE1H121JCQ	120p	
	C669	ECUE1H121JCQ	120p	
	C805	F1G1H2R7A480	2.7p	
	C806	F1G1H2R7A480	2.7p	
	C810	F1G1H2R4A480	2.4p	
	C811	ECUE1H100DCQ	10p	S
	C812	F1G1HR90A480	0.9p	
	C813	F1G1H2R0A480	2p	
	C814	F1G1H5R0A480	5p	
	C820	F1G1HR5A480	1.5p	
	C822	ECUE1H100DCQ	10p	S
	C825	ECUE1H100DCQ	10p	S
	C826	ECUE1H100DCQ	10p	S
	C827	ECUE1H100DCQ	10p	S

Safety	Ref. No.	Part No.	Part Name & Description	Remarks
	C828	ECUE1H100DCQ	10p	S
	C859	F1G1H2R2A480	2.2p	
	C863	F1G1HR5A480	1.5p	
	C890	ECUE1H100DCQ	10p	S
	C891	ECUE1H100DCQ	10p	S
	C892	ECUE1H100DCQ	10p	S
	C893	ECUE1H100DCQ	10p	S
	C894	ECUE1H100DCQ	10p	S
	C895	F1G1HR2A480	1.2p	
	C896	F1G1H2R2A480	2.2p	
	C897	ECUE1H100DCQ	10p	S
	C900	ECUE1H100DCQ	10p	
	C901	ECUE1H681KBQ	680p	
	C902	ECUV1A105KBV	1	
	C903	ECUE1H681KBQ	680p	
	C904	ECUE1H102KBQ	0.001	
	C905	ECUE1H102KBQ	0.001	
	C906	ECUE1H331KBQ	330p	
	C908	PQCUV0J106KB	10	
	C910	ECUE1H101JCQ	100p	S
	C912	F2A1C1010119	100	
	C918	ECUE1C333KBQ	0.033	
	C919	ECUE1C333KBQ	0.033	
	C924	F2A0J1020031	1000	
	C925	ECUE1H102KBQ	0.001	
	C928	F0C2E1050005	1	
	C929	F1K1H475A199	4.7	S
	C930	ECUV1C563KBV	0.056	
	C931	ECUV1C474KBV	0.47	
	C932	ECUE1A104KBQ	0.1	
	C933	ECJ1VB0G106M	10	S
	C934	ECUE1H102KBQ	0.001	
	C935	ECUE1H102KBQ	0.001	
	C936	ECUE1H102KBQ	0.001	
	C937	F2A1C1010119	100	
	C940	ECUE1C103KBQ	0.01	
	C941	ECUE1H100DCQ	10p	S
	C942	ECUE1H100DCQ	10p	S
	C943	ECUE1H100DCQ	10p	S
	C944	ECUE1H100DCQ	10p	S
			(OTHERS)	
	E1	PNMC1018Z	CASE, MAGNETIC SHIELD (*2)	
	MIC1	L0CBAY000018	MICROPHONE	
	IC902	B3PBA0000138	PHOTO ELECTRIC TRANSDUCER	
	CN1	K1MN08BA0111	CONNECTOR	
	P101	D4DAY220A022	THERMISTOR (POSISTOR)	
	R1014	D4CC1222A033	THERMISTOR (POSISTOR)	
	X501	H0J138500011	CRYSTAL OSCILLATOR (*1)	
	F1	K5H302Y00003	FUSE	

16.5.1.3. Operational P.C. Board Parts

Safety	Ref. No.	Part No.	Part Name & Description	Remarks
	PCB2	PNWP2TG6671H	OPERATIONAL P.C.BOARD ASS'Y (RTL)	
			(LEDS)	
	LED901	LNJ826W83RA	LED	
	LED902	LNJ826W83RA	LED	
	LED903	LNJ826W83RA	LED	
			(SWITCH)	
	SW901	K0L1LB000021	SPECIAL SWITCH	

16.5.1.4. LCD Board Parts

Safety	Ref. No.	Part No.	Part Name & Description	Remarks
	PCB3	PNWP3TG6671H	LCD RELAY P.C.BOARD ASS'Y (RTL)	
			(RESISTORS)	
	R7	PQ4R10XJ560	56	S

Safety	Ref. No.	Part No.	Part Name & Description	Remarks
	R8	PQ4R10XJ221	220	S
	R9	PQ4R10XJ560	56	S
	R10	PQ4R10XJ221	220	S
	R11	PQ4R10XJ221	220	S
	R12	PQ4R10XJ105	1M	S
	R13	ERJ6GEY0R00	0	S
			(CAPACITORS)	
	C1	F1H1E1050001	1	
	C2	F1H1E1050001	1	
	C3	F1H1E1050001	1	
	C4	F1H1E1050001	1	
	C5	F1H1E1050001	1	
	C6	F1H1E1050001	1	
	C7	F1H1E1050001	1	
	C8	F1H1E1050001	1	
	C9	F1H1E1050001	1	
	C10	F1H1E1050001	1	
	C12	ECUV1H221JCV	220p	
	C13	ECUV1H221JCV	220p	
	C14	ECUV1H680JCV	68p	
	C15	ECUV1H101JCV	100p	
	C16	ECUV1H221JCV	220p	
			(CONNECTORS)	
	CN1	K1MN08BA0111	CONNECTOR	
	CN2	K1MN20BA0111	CONNECTOR	

16.5.1.5. LED Board parts

Safety	Ref. No.	Part No.	Part Name & Description	Remarks
			(LEDS)	
	LED1	B3AFB0000211	LED	
	LED2	B3AFB0000211	LED	
			(RESISTORS)	
	R14	ERJ3GEYJ330	33	S
	R15	ERJ3GEYJ330	33	S

16.5.2. Portable

16.5.2.1. Cabinet and Electrical Parts

Safety	Ref. No.	Part No.	Part Name & Description	Remarks
	101	PNGP1136Z1	PANEL, LCD	PMMA-HB
	102	PNYE1041Z	TAPE, DOUBLE SIDED	
	103	PNKM1184Z1	CABINET BODY	ABS-HB
	104	PNHR1390Z	OPTIC CONDUCTIVE PARTS, LED LENS	PS-HB
	105	LOAD01A00026	RECEIVER	
	106	PNYE1040Z	SPACER, CUSHION LCD	
	107	PNBC1354Z1	BUTTON, NAVIGATOR KEY	ABS-HB
	108	PNJK1104Y	KEYBOARD SWITCH	
	109	PNJT1057Z	CHARGE TERMINAL (L)	
	110	PNJT1058Z	CHARGE TERMINAL (R)	
	111	PQHR11315Z	GUIDE, SPEAKER	ABS-HB
	112	LOAA02A00095	SPEAKER	
	113	PQHS10784Y	SPACER, SPEAKER NET	
	114	PQJC10056W	BATTERY TERMINAL	
	115	PNKE1091Z1	COVER, EP CAP	
	116	PNKF1133Z1	CABINET COVER	ABS-HB
	117	PNKE1092Z1	COVER, RUBBER GRIP	
	118	PNQT2062Z	LABEL, BATTERY	
	119	PNGT5515Z	NAME PLATE	
	120	PNHS1079Z	SPACER, BATTERY	
	121	PNKK1052Z1	LID, BATTERY	ABS-HB
	122	PNYNTGA660BR	LID, BATTERY ASS'Y	ABS-HB

16.5.2.2. Main P.C. Board Parts

Note:

(*1) Reconfirm the model No. written on the Portable's name plate when replacing PCB100. Because the model

No. of the optional Portable may differ from the included Portable.

(*2) When replacing IC3 or X1, make the adjustment using PNZZTG6671B. Refer to **Portable (P.60)** of Things to Do after Replacing IC or X'tal.

(*3) When replacing the Portable LCD, See **How to Replace the Portable LCD (P.51)**.

Safety	Ref. No.	Part No.	Part Name & Description	Remarks
	PCB100	PNWP1TGA660R	MAIN P.C.BOARD ASS'Y (RTL) (*1)	
			(ICs)	
	IC1	C2HBCY000081	IC	
	IC3	PNWITGA660BR	IC (EEPROM) (*2)	
	IC4	C0DBZYY00357	IC	
			(TRANSISTORS)	
	Q2	B1ADCF000040	TRANSISTOR (SI)	
	Q3	B1ABGE000011	TRANSISTOR (SI)	
	Q4	B1ADCF000040	TRANSISTOR (SI)	
	Q5	B1GBCFYY0010	TRANSISTOR (SI)	
	Q6	B1GBCFYY0010	TRANSISTOR (SI)	
	Q9	B1ABDF000017	TRANSISTOR (SI)	
	Q10	B1ADNB000003	TRANSISTOR (SI)	
	Q11	B1ABDF000017	TRANSISTOR (SI)	
	Q12	B1ADCF000040	TRANSISTOR (SI)	
			(DIODES)	
	D13	MA8043	DIODE (SI)	S
	D14	MA8043	DIODE (SI)	S
	D21	MA8043	DIODE (SI)	S
	D22	MA8043	DIODE (SI)	S
	DA801	B0DDCD000001	DIODE (SI)	
			(LEDS)	
	LED1	B3ACB0000216	LED	
	LED2	B3ACB0000216	LED	
	LED3	B3ACB0000216	LED	
	LED4	B3ACB0000216	LED	
	LED5	B3ACB0000216	LED	
	LED6	B3ACB0000216	LED	
	LED12	B3ACB0000216	LED	
			(COILS)	
	C812	PQLQR4C8N2J	COIL	S
	L13	G1CR18J00004	COIL	
			(RESISTOR ARRAYS)	
	RA2	D1H83314A013	RESISTOR ARRAY	S
	RA3	D1H433120001	RESISTOR ARRAY	
	RA4	D1H433220001	RESISTOR ARRAY	
	RA5	EXB28V332JX	RESISTOR ARRAY (IC FILTERS)	
	L29	J0JDC0000045	IC FILTER	
	L72	J0JCC0000276	IC FILTER	
	R308	J0JCC0000286	IC FILTER	
			(RESISTORS)	
	R2	ERJ2GEJ303	30k	S
	R3	ERJ2GEJ152	1.5k	S
	R4	ERJ2GEJ473	47k	S
	R6	ERJ2GEJ103	10k	S
	R7	ERJ2GEJ104	100k	S
	R8	ERJ8GEYJ3R3	3.3	S
	R9	ERJ2GEJ303	30k	S
	R10	ERJ3GEYJ1R0	1	S
	R11	ERJ2GEJ681	680	S
	R12	ERJ2GEJ183	18k	S
	R13	ERJ2GEJ103	10k	S
	R19	ERJ2RKF2003	200k	S
	R20	ERJ2RKF1003	100k	S
	R21	ERJ2RKF1003	100k	S
	R22	ERJ2GEJ332	3.3k	S
	R23	ERJ2GEJ100	10	S
	R24	ERJ2GEJ391	390	S
	R25	ERJ2GEJ222	2.2k	S
	R26	ERJ2GEJ332	3.3k	S
	R27	ERJ2GEJ222	2.2k	S

Safety	Ref. No.	Part No.	Part Name & Description	Remarks
	R28	ERJ2GEJ222	2.2k	S
	R31	ERJ2RKF1003	100k	
	R32	ERJ2GEJ104	100k	S
	R33	ERJ2RKF1003	100k	
	R34	ERJ2GEJ391	390	S
	R45	ERJ6RSJR10V	0.1	
	R64	ERJ2GEJ222	2.2k	S
	R66	ERJ2GEJ103	10k	S
	R67	ERJ2GEJ103	10k	S
	R68	ERJ2GEJ103	10k	S
	R69	ERJ2GEJ103	10k	S
	R73	ERJ2GEJ330	33	S
	R74	ERJ2GEJ330	33	S
	R306	ERJ2GEJ101	100	S
	R509	ERJ2GEJ560X	56	S
	R561	ERJ2GEJ221	220	S
	R563	ERJ2GEOR00	0	S
	R806	ERJ2GEJ471	470	S
	R807	ERJ2GEJ471	470	S
	L9	ERJ2GEOR00	0	S
	L74	ERJ2GEJ100	10	S
			(CAPACITORS)	
	C1	EEE0JA221WP	220	
	C2	EEE0JA221WP	220	
	C4	ECUE1H390JCQ	39p	
	C5	ECUE1A104KBQ	0.1	
	C8	ECUE1H100DCQ	10p	
	C9	ECUE1H120JCQ	12p	
	C10	EEE0JA221WP	220	
	C11	ECUE1A104KBQ	0.1	
	C12	PQCUV0J106KB	10	
	C13	ECUE1A104KBQ	0.1	
	C14	ECUV1C393KBV	0.039	
	C15	ECUE1H390JCQ	39p	
	C16	ECUV1C393KBV	0.039	
	C17	ECUE1H100DCQ	10p	
	C18	ECUE1H100DCQ	10p	
	C19	ECUE1H102KBQ	0.001	
	C20	ECJ1VB0G106M	10	S
	C21	ECUV1A105KBV	1	
	C22	ECUE1A104KBQ	0.1	
	C23	ECUE1A104KBQ	0.1	
	C24	ECUE0J105KBQ	1	
	C25	ECUV1A225KBV	2.2	
	C26	ECJ1VB0G106M	10	S
	C29	ECUV1A105KBV	1	
	C30	ECJ1VB0G106M	10	S
	C31	ECUE0J105KBQ	1	
	C32	ECUE0J105KBQ	1	
	C33	ECUE1A104KBQ	0.1	
	C34	ECUE1H390JCQ	39p	
	C36	ECUE1A104KBQ	0.1	
	C37	ECJ1VB0G106M	10	S
	C40	ECUE1A104KBQ	0.1	
	C41	ECUE1A104KBQ	0.1	
	C43	ECUE1A104KBQ	0.1	
	C44	ECUE0J105KBQ	1	
	C45	ECUE1A104KBQ	0.1	
	C46	ECUE1H100DCQ	10p	S
	C51	ECJ1VB0G106M	10	S
	C56	ECUV1A105KBV	1	
	C57	ECUV1A105KBV	1	
	C58	ECUE0J105KBQ	1	
	C72	ECUE1H100DCQ	10p	
	C73	ECUE1H100DCQ	10p	
	C76	ECUE1H100DCQ	10p	
	C77	ECUE1H100DCQ	10p	
	C78	ECUE1H390JCQ	39p	
	C79	ECUE1H101JCQ	100p	
	C80	ECUE1H390JCQ	39p	
	C81	ECUE1H101JCQ	100p	
	C82	ECUE1H471KBQ	470p	
	C83	ECUE1H100DCQ	10p	

Safety	Ref. No.	Part No.	Part Name & Description	Remarks
	C86	FLJ0J2260002	22	
	C96	ECUE1H100DCQ	10p	
	C97	ECUE1H100DCQ	10p	
	C110	ECUE1H102KBQ	0.001	
	C127	ECUE1H102KBQ	0.001	
	C150	ECUE1A104KBQ	0.1	
	C152	ECUE1H102KBQ	0.001	
	C172	ECUE1A104KBQ	0.1	
	C183	ECUE1H100DCQ	10p	
	C184	ECUE1H100DCQ	10p	
	C185	ECUE1H102KBQ	0.001	
	C188	ECUE0J105KBQ	1	
	C504	ECUV1C105KBV	1	
	C505	ECUE0J105KBQ	1	
	C805	F1G1H2R4A480	2.4p	
	C806	F1G1H2R4A480	2.4p	
	C810	F1G1H2R5A480	2.5p	
	C811	ECUE1H101JCQ	100p	S
	C813	F1G1H1R6A480	1.6p	
	C820	F1G1H1R8A480	1.8p	
	C822	ECUE1H100DCQ	10p	S
	C825	ECUE1H100DCQ	10p	S
	C826	ECUE1H100DCQ	10p	S
	C859	F1G1H2R0A480	2p	
	C863	F1G1H1R8A480	1.8p	
	C895	F1G1H1R3A480	1.3p	
	C896	F1G1H1R8A480	1.8p	
	C897	F1G1H240A557	24p	
	L809	F1G1H1R0A480	1p	
			(OTHERS)	
	MIC100	LOCBAY000053	MICROPHONE	
	E101	L5DYBY00001	LIQUID CRYSTAL DISPLAY (*3)	
	E102	PNHR1295Z	TRANSPARENT PLATE, LCD	PMMA-HB
	E103	PNHR1389Z	GUIDE, LCD	ABS-HB
	E104	PNHX1407Z	COVER, LCD	
	E105	PNLA1049Z	ANTENNA	
	E106	PNVE1002Z	BATTERY TERMINAL	ABS-HB
	E107	PQHG10729Z	RUBBER PARTS, RECEIVER	
	CN4	K2HD103D0001	JACK	
	F1	K5H252Y00002	FUSE	
	X1	H0J138500003	CRYSTAL OSCILLATOR (*2)	S

16.5.2.3. LED Board Parts

Safety	Ref. No.	Part No.	Part Name & Description	Remarks
	PCB101	PNWP2TGA660R	LED P.C.BOARD ASS'Y (RTL)	
			(LED)	
	WLED	B3AFB0000370	LED	

16.5.3. Charger Unit

16.5.3.1. Cabinet and Electrical Parts

Safety	Ref. No.	Part No.	Part Name & Description	Remarks
	200	PNLC1017ZB	CHARGER UNIT ASS'Y without NAME PLATE (RTL)	
	200-1	PNKM1201Z1	CABINET BODY	PS-HB
	200-2	PNJT1065Z	CHARGE TERMINAL	
	200-3	PNKF1147Z1	CABINET COVER	PS-HB
	200-4	PQHA10023Z	RUBBER PARTS, FOOT CUSHION	
	201	PNGT5532Z	NAME PLATE	

16.5.3.2. Main P.C. Board Parts

Safety	Ref. No.	Part No.	Part Name & Description	Remarks
	PCB200	PNWPTGA660CH	MAIN P.C.BOARD ASS'Y (RTL)	
			(JACK)	
	J1	K2ECYB000001	JACK	S
			(RESISTOR)	
	R1	ERX2SJ6R8	6.8	
			(FUSE)	
⚠	F1	K5H302Y00003	FUSE	

Safety	Ref. No.	Part No.	Part Name & Description	Remarks
		PQZZ1CD300E	JIG CABLE (*1)	
		PNZZTG6671B	BATCH FILE CD-ROM (*1)	
		PQZZ430PIR	TIP OF SOLDERING IRON (*2)	
		PQZZ430PRB	RUBBER OF SOLDERING IRON (*2)	

16.5.4. Accessories and Packing Materials

Note:

(*1) You can download and refer to the Operating Instructions (Instruction book) on TSN Server.

16.5.4.1. KX-TG6671B

Safety	Ref. No.	Part No.	Part Name & Description	Remarks
⚠	A1	PNLV226Z	AC ADAPTOR	
	A2	PQJA10075Z	CORD, TELEPHONE	
	A3	PQJA212V	CORD, PORTABLE	
	A4	PNLXP1010Z	PORTABLE	
	A5	PNKE1098Z1	HANGER, BELT CLIP	ABS-HB
	A6	PNQX3144Z	INSTRUCTION BOOK (*1)	
	P1	PNPK3422001Z	GIFT BOX	
	P2	PNPD1551Z	CUSHION	

16.5.4.2. KX-TG6672B

Safety	Ref. No.	Part No.	Part Name & Description	Remarks
⚠	A101	PNLV226Z	AC ADAPTOR	
	A102	PQJA10075Z	CORD, TELEPHONE	
	A103	PQJA212V	CORD, PORTABLE	
	A104	PNLXP1010Z	PORTABLE	
	A105	PNKE1098Z1	HANGER, BELT CLIP	ABS-HB
	A106	PNQX3144Z	INSTRUCTION BOOK (*1)	
	P101	PNPK3423001Z	GIFT BOX	
	P102	PNPD1552Z	CUSHION	

16.5.4.3. KX-TGA660B

Safety	Ref. No.	Part No.	Part Name & Description	Remarks
⚠	A201	PNLV226Z	AC ADAPTOR	
	A202	PNQX3161Z	INSTRUCTION BOOK (*1)	
	A203	PNKE1098Z1	HANGER, BELT CLIP	ABS-HB
	P201	PNPK3288001Z	GIFT BOX	

16.5.5. Screws

Safety	Ref. No.	Part No.	Part Name & Description	Remarks
	A	XTB26+8GFJ	TAPPING SCREW	
	B	XTB2+8GFJ	TAPPING SCREW	

16.5.6. Fixtures and Tools

Note:

(*1) See **Equipment Required** (P.52), and **The Setting Method of JIG** (P.52)

(*2) When replacing the Portable LCD, See **How to Replace the Portable LCD** (P.51)

T./N
KXTG6671B
KXTG6672B
KXTGA660B

Service Manual

Telephone Equipment

Model No. **KX-TG6671B**
KX-TG6672B
KX-TGA660B

Digital Coded/Cordless Answering
System

B: Black Version
(for U.S.A.)

Supplement-3

Please file and use this supplement manual together with the service manual for Model No.KX-TG6671B/
KX-TG6672B/KX-TGA660B, Order No. KM41108473CE.

WARNING

This service information is designed for experienced repair technicians only and is not designed for use by the general public. It does not contain warnings or cautions to advise non-technical individuals of potential dangers in attempting to service a product. Products powered by electricity should be serviced or repaired only by experienced professional technicians. Any attempt to service or repair the product or products dealt with in this service information by anyone else could result in serious injury or death.









TABLE OF CONTENTS

	PAGE
1 REPLACEMENT PARTS LIST -----	2
1.1. REFERENCE CHART-----	2
1.2. ORIGINAL AND NEW PARTS COMPARISON LISTS-----	2

1 REPLACEMENT PARTS LIST

1.1. REFERENCE CHART

Reason for Change	
*The following items (1-8) indicate the reason for change. See the "Notes" column for each part in ORIGINAL AND NEW PARTS COMPARISON LISTS .	
1. Improve performance	Remarks: *c: To share the parts with other models.
2. Change of material or dimension	
3. To meet approved specification	
4. Standardization	
5. Addition	
6. Deletion	
7. Correction	
8. Other	

Interchangeability Code		
**The following items (V-Z) indicate the Interchangeability. See the "Notes" column for each part in ORIGINAL AND NEW PARTS COMPARISON LISTS .		
V	Original  Early (before change) New  Late (after change)	Original or new parts may be used in early or late production sets. Use original parts until exhausted, then stock new parts.
W	Original  Early (before change) New  Late (after change)	Original parts may be used in early production sets only. New parts may be used in early or late production sets. Use original parts where possible, then stock new parts.
X	Original  Early (before change) New  Late (after change)	New parts only may be used in early or late production sets. Stock new parts.
Y	Original  Early (before change) New  Late (after change)	Original parts may be used in early production sets only. New parts may be used in late production sets only. Stock both original and new parts.
Z	Other	

Note:

Alphabets in the "Remarks" column in the following lists correspond to the alphabets in the "Remarks" in REFERENCE CHART.

1.2. ORIGINAL AND NEW PARTS COMPARISON LISTS

Ref. No.	Part No.		Part Name & Description	Pcs/ Set	Remarks	Notes	Time of Change (Suffix)
	Original (Old)	New					
Main P.C.Board Parts (Portable) (For PNLPTGA660R1ZA)							
C1	EEE0JA221WP	-----	CAPACITOR, 220 μ F	0	*c	6 -	---
C10	EEE0JA221WP	-----	CAPACITOR, 220 μ F	0	*c	6 -	---
Main P.C.Board Parts (Portable) (For PNLPTGA660R1YA)							
C1	EEE0JA221WP	-----	CAPACITOR, 220 μ F	0	*c	6 -	---
C10	EEE0JA221WP	-----	CAPACITOR, 220 μ F	0	*c	6 -	---

Service Manual

Telephone Equipment

Model No. **KX-TG6671B**
KX-TG6672B
KX-TGA660B

Digital Corded/Cordless Answering
System

B: Black Version
(for U.S.A.)

Supplement-2

Please file and use this supplement manual together with the service manual for Model No.KX-TG6671B/
KX-TG6672B/KX-TGA660B, Order No. KM41108473CE.

WARNING

This service information is designed for experienced repair technicians only and is not designed for use by the general public. It does not contain warnings or cautions to advise non-technical individuals of potential dangers in attempting to service a product. Products powered by electricity should be serviced or repaired only by experienced professional technicians. Any attempt to service or repair the product or products dealt with in this service information by anyone else could result in serious injury or death.









TABLE OF CONTENTS

	PAGE
1 REPLACEMENT PARTS LIST -----	2
1.1. REFERENCE CHART-----	2
1.2. ORIGINAL AND NEW PARTS COMPARISON LISTS-----	2

1 REPLACEMENT PARTS LIST

1.1. REFERENCE CHART

Reason for Change	
**The following items (1-8) indicate the reason for change. See the "Notes" column for each part in ORIGINAL AND NEW PARTS COMPARISON LISTS.	
1. Improve performance	Remark: *c: To share the parts with other models
2. Change of material or dimension	
3. To meet approved specification	
4. Standardization	
5. Addition	
6. Deletion	
7. Correction	
8. Other	

Interchangeability Code		
**The following items (V-Z) indicate the Interchangeability. See the "Notes" column for each part in ORIGINAL AND NEW PARTS COMPARISON LISTS.		
V	Original  Early (before change) New  Late (after change)	Original or new parts may be used in early or late production sets. Use original parts until exhausted, then stock new parts.
W	Original  Early (before change) New  Late (after change)	Original parts may be used in early production sets only. New parts may be used in early or late production sets. Use original parts where possible, then stock new parts.
X	Original  Early (before change) New  Late (after change)	New parts only may be used in early or late production sets. Stock new parts.
Y	Original  Early (before change) New  Late (after change)	Original parts may be used in early production sets only. New parts may be used in late production sets only. Stock both original and new parts.
Z	Other	

Note:

Alphabets in the "Remarks" column in the following lists correspond to the alphabets in the "Remarks" in REFERENCE CHART.

1.2. ORIGINAL AND NEW PARTS COMPARISON LISTS

Change of the Suffix Code

Suffix Code	Reasons of change
A to B	To share the parts with other models.

Serial No. Label tells you the suffix code as follows.

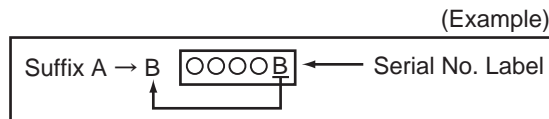

Ref. No.	Part No.		Part Name & Description	Pcs/ Set	Remarks	Notes	Time of Change (Suffix)
	Original (Old)	New					
Main P.C.Board Parts (Base Unit)							
IC501	C2HBCY000094	C2HBCY000093	IC	1	*c	4 V	A to B

Service Manual

Telephone Equipment

Model No. **KX-TG6671B**
KX-TG6672B
KX-TGA660B

Digital Corded/Cordless Answering
System

B: Black Version
(for U.S.A.)



Please file and use this supplement manual together with the service manual for Model No.KX-TG6671B/
KX-TG6672B/KX-TGA660B,KM41108473CE.

WARNING

This service information is designed for experienced repair technicians only and is not designed for use by the general public. It does not contain warnings or cautions to advise non-technical individuals of potential dangers in attempting to service a product. Products powered by electricity should be serviced or repaired only by experienced professional technicians. Any attempt to service or repair the product or products dealt with in this service information by anyone else could result in serious injury or death.

TABLE OF CONTENTS

	PAGE
1 REPLACEMENT PARTS LIST -----	2
1.1. REFERENCE CHART-----	2
1.2. ORIGINAL AND NEW PARTS COMPARISON LISTS -----	2
2 ADDITIONS -----	3
2.1. Accessories and Packing Materials (KX- TG6671B) -----	3
2.2. Accessories and Packing Materials (KX- TG6672B) -----	4

1 REPLACEMENT PARTS LIST

1.1. REFERENCE CHART

Reason for Change	
*The following items (1-8) indicate the reason for change. See the "Notes" column for each part in ORIGINAL AND NEW PARTS COMPARISON LISTS.	
1. Improve performance	Remarks: *c : To share the parts with other models. *n: To correct error writing.
2. Change of material or dimension	
3. To meet approved specification	
4. Standardization	
5. Addition	
6. Deletion	
7. Correction	
8. Other	

Interchangeability Code		
**The following items (V-Z) indicate the Interchangeability. See the "Notes" column for each part in ORIGINAL AND NEW PARTS COMPARISON LISTS.		
V	Original Early (before change) New Late (after change)	Original or new parts may be used in early or late production sets. Use original parts until exhausted, then stock new parts.
W	Original Early (before change) New Late (after change)	Original parts may be used in early production sets only. New parts may be used in early or late production sets. Use original parts where possible, then stock new parts.
X	Original Early (before change) New Late (after change)	New parts only may be used in early or late production sets. Stock new parts.
Y	Original Early (before change) New Late (after change)	Original parts may be used in early production sets only. New parts may be used in late production sets only. Stock both original and new parts.
Z	Other	

Note:

Alphabets in the "Remarks" column in the following lists correspond to the alphabets in the "Remarks" in REFERENCE CHART.

1.2. ORIGINAL AND NEW PARTS COMPARISON LISTS

Ref. No.	Part No.		Part Name & Description	Pcs/ Set	Remarks	Notes		Time of Change (Suffix)
	Original (Old)	New						
LCD Board Parts								
PCB3	PNWP3TG6671H	PNWP3TG9471H	LCD RELAY P.C.BOARD ASS'Y (RTL)	1	*n	7	-	---
Accessories and Packing Materials (KX-TG6671B)								
P3	-----	PNPD1632Z	PAD	2	*c	5	-	---
P4	-----	PNPD1635Z	PAD	1	*c	5	-	---
Accessories and Packing Materials (KX-TG6672B)								
P103	-----	PNPD1632Z	PAD	2	*c	5	-	---
P104	-----	PNPD1635Z	PAD	1	*c	5	-	---

2 ADDITIONS

2.1. Accessories and Packing Materials (KX-TG6671B)

[Added into original section "16.4.1 Accessories and Packing Materials (KX-TG6671B)"]

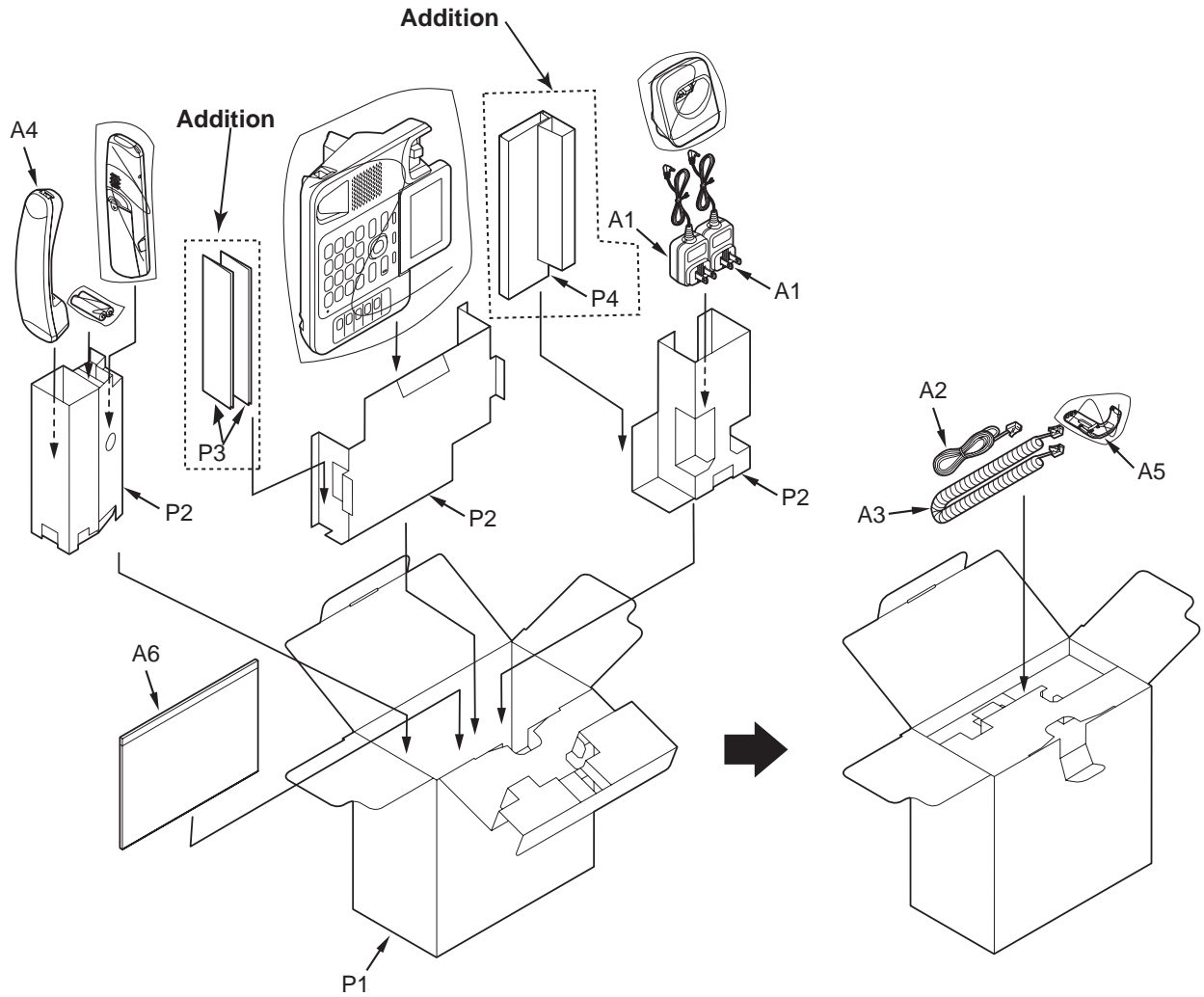

2.2. Accessories and Packing Materials (KX-TG6672B)

[Added into original section "16.4.2 Accessories and Packing Materials (KX-TG6672B)"]

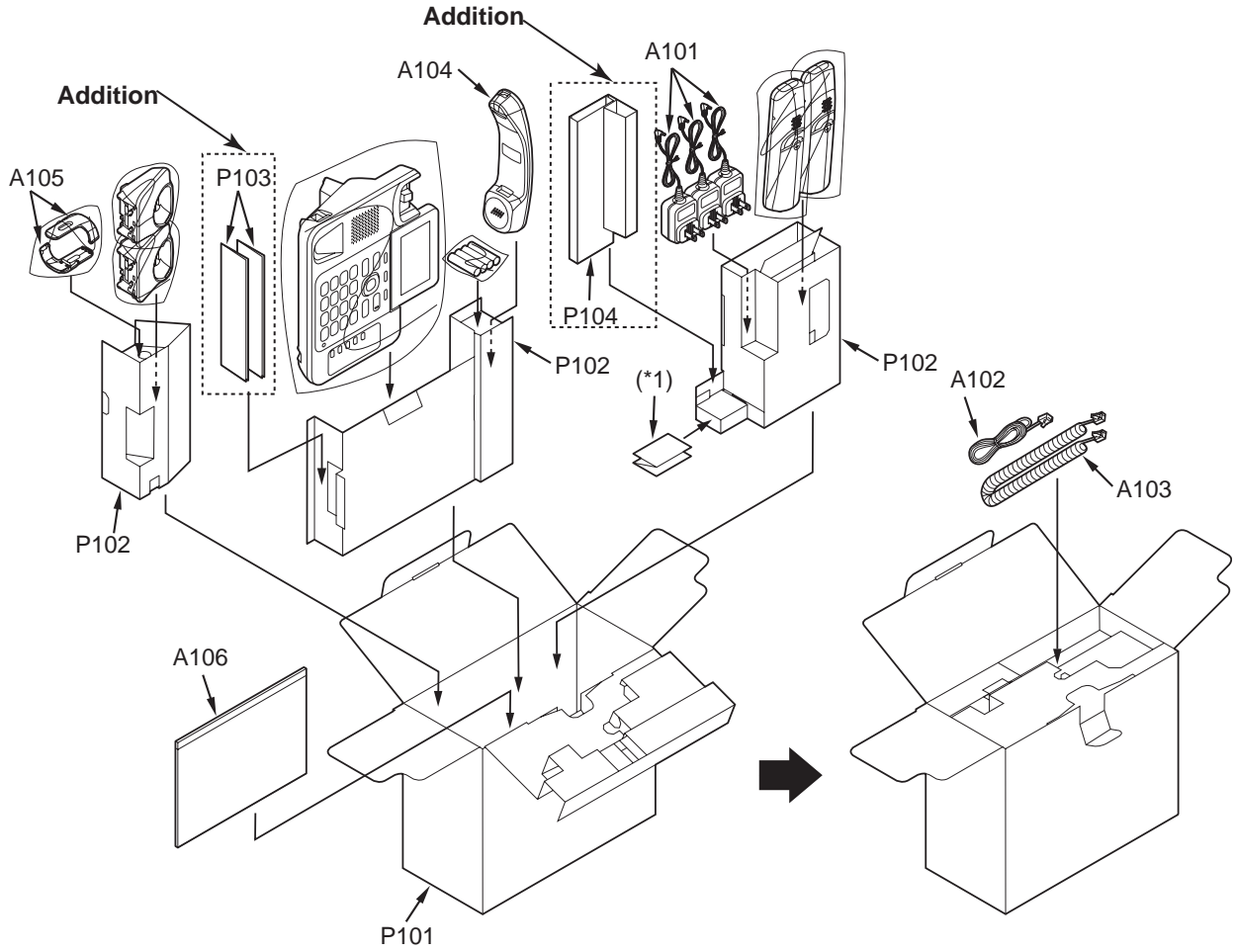

Note:

(*1) This pad is a piece of Ref No. P101 (GIFT BOX).

Y.M
KXTG6671B
KXTG6672B
KXTGA660B

Service Manual

Telephone Equipment

Model No. **KX-TG6671B**
KX-TG6672B
KX-TGA660B

Digital Corded/Cordless Answering
System

B: Black Version
(for U.S.A.)

Supplement-4

Please file and use this supplement manual together with the service manual for Model No.KX-TG6671B/
KX-TG6672B/KX-TGA660B, Order No. KM41108473CE.

WARNING

This service information is designed for experienced repair technicians only and is not designed for use by the general public. It does not contain warnings or cautions to advise non-technical individuals of potential dangers in attempting to service a product. Products powered by electricity should be serviced or repaired only by experienced professional technicians. Any attempt to service or repair the product or products dealt with in this service information by anyone else could result in serious injury or death.









TABLE OF CONTENTS

	PAGE
1 REPLACEMENT PARTS LIST -----	2
1.1. REFERENCE CHART-----	2
1.2. ORIGINAL AND NEW PARTS COMPARISON LISTS-----	2

1 REPLACEMENT PARTS LIST

1.1. REFERENCE CHART

Reason for Change	
*The following items (1-8) indicate the reason for change. See the "Notes" column for each part in ORIGINAL AND NEW PARTS COMPARISON LISTS .	
1. Improve performance	Remarks: *j : To meet the standards.
2. Change of material or dimension	
3. To meet approved specification	
4. Standardization	
5. Addition	
6. Deletion	
7. Correction	
8. Other	

Interchangeability Code		
**The following items (V-Z) indicate the Interchangeability. See the "Notes" column for each part in ORIGINAL AND NEW PARTS COMPARISON LISTS .		
V	Original  Early (before change) New  Late (after change)	Original or new parts may be used in early or late production sets. Use original parts until exhausted, then stock new parts.
W	Original  Early (before change) New  Late (after change)	Original parts may be used in early production sets only. New parts may be used in early or late production sets. Use original parts where possible, then stock new parts.
X	Original  Early (before change) New  Late (after change)	New parts only may be used in early or late production sets. Stock new parts.
Y	Original  Early (before change) New  Late (after change)	Original parts may be used in early production sets only. New parts may be used in late production sets only. Stock both original and new parts.
Z	Other	

Note:

Alphabets in the "Remarks" column in the following lists correspond to the alphabets in the "Remarks" in REFERENCE CHART.

1.2. ORIGINAL AND NEW PARTS COMPARISON LISTS

Ref. No.	Part No.		Part Name & Description	Pcs/ Set	Remarks	Notes	Time of Change (Suffix)
	Original (Old)	New					
Cabinet and Electrical Parts (Portable)							
119	PNGT5515Z	PNGT7240Z	NAME PLATE	1	*j	4 Y	---

NM
KXTG6671B
KXTG6672B
KXTGA660B