

# Service Manual

Telephone Equipment

Model No. **KX-TG7741S**  
**KX-TG7742S**  
**KX-TG7743S**  
**KX-TGA470S**

Link-to-Cell Cellular Convergence  
Solution

S: Silver Version  
(for U.S.A.)

DECT  
**6.0**

 **Bluetooth®**



KX-TGA470S  
(Handset)

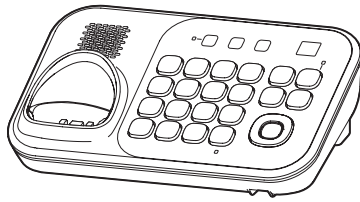

KX-TG7741S  
(Base Unit)



(Charger Unit)

**Configuration for each model**

Model No	Base Unit	Handset	Charger Unit	Expandable
KX-TG7741	1 (TG7741)	1 (TGA470)		Up to 6
KX-TG7742	1 (TG7741)	2 (TGA470)	1	Up to 6
KX-TG7743	1 (TG7741)	3 (TGA470)	2	Up to 6
KX-TGA470*		1 (TGA470)	1	

\*KX-TGA470 is also an optional accessory, which contains a handset and a charger.

 **WARNING**

This service information is designed for experienced repair technicians only and is not designed for use by the general public. It does not contain warnings or cautions to advise non-technical individuals of potential dangers in attempting to service a product. Products powered by electricity should be serviced or repaired only by experienced professional technicians. Any attempt to service or repair the product or products dealt with in this service information by anyone else could result in serious injury or death.

**IMPORTANT SAFETY NOTICE**

There are special components used in this equipment which are important for safety. These parts are marked by  in the Schematic Diagrams, Circuit Board Diagrams, Exploded Views and Replacement Parts List. It is essential that these critical parts should be replaced with manufacturer's specified parts to prevent shock, fire or other hazards. Do not modify the original design without permission of manufacturer.

**IMPORTANT INFORMATION ABOUT LEAD FREE, (PbF), SOLDERING**

If lead free solder was used in the manufacture of this product, the printed circuit boards will be marked PbF. Standard leaded, (Pb), solder can be used as usual on boards without the PbF mark. When this mark does appear, please read and follow the special instructions described in this manual on the use of PbF and how it might be permissible to use Pb solder during service and repair work.

- When you note the serial number, write down all 11 digits. The serial number may be found on the bottom of the unit.
- The illustrations in this Service Manual may vary slightly from the actual product.

# TABLE OF CONTENTS

	PAGE		PAGE
<b>1 Safety Precautions</b> -----	<b>4</b>	15.2. Circuit Board (Base Unit_Operation)-----	83
1.1. For Service Technicians -----	4	15.3. Circuit Board (Handset_Main) -----	84
<b>2 Warning</b> -----	<b>4</b>	15.4. Circuit Board (Handset_LED)-----	86
2.1. Battery Caution-----	4	15.5. Circuit Board (Charger Unit)-----	87
2.2. About Lead Free Solder (PbF: Pb free)-----	4	<b>16 Exploded View and Replacement Parts List</b> -----	<b>88</b>
2.3. Discarding of P. C. Board-----	5	16.1. Cabinet and Electrical Parts (Base Unit)-----	88
<b>3 Specifications</b> -----	<b>6</b>	16.2. Cabinet and Electrical Parts (Handset)-----	89
<b>4 Technical Descriptions</b> -----	<b>7</b>	16.3. Cabinet and Electrical Parts (Charger Unit)-----	90
4.1. Circuit Configuration of TG774x Series		16.4. Accessories and Packing Materials -----	91
Phones -----	7	16.5. Replacement Parts List-----	95
4.2. US-DECT Description -----	8		
4.3. Block Diagram (Base Unit_Main)-----	10		
4.4. Tel Interface Circuit-----	11		
4.5. Block Diagram (Base Unit_RF Part)-----	12		
4.6. Circuit Operation (Base Unit)-----	13		
4.7. Block Diagram (Handset)-----	20		
4.8. Block Diagram (Handset_RF Part)-----	21		
4.9. Circuit Operation (Handset)-----	22		
4.10. Circuit Operation (Charger Unit)-----	23		
4.11. Signal Route -----	24		
<b>5 Location of Controls and Components</b> -----	<b>26</b>		
<b>6 Installation Instructions</b> -----	<b>26</b>		
<b>7 Operating Instructions</b> -----	<b>26</b>		
<b>8 Test Mode</b> -----	<b>27</b>		
8.1. Engineering Mode-----	27		
<b>9 Service Mode</b> -----	<b>31</b>		
9.1. How to Clear User Setting (Handset Only)-----	31		
<b>10 Troubleshooting Guide</b> -----	<b>32</b>		
10.1. Troubleshooting Flowchart -----	32		
<b>11 Disassembly and Assembly Instructions</b> -----	<b>48</b>		
11.1. Disassembly Instructions -----	48		
11.2. How to Replace the Base unit LCD-----	52		
11.3. How to Replace the Handset LCD -----	54		
<b>12 Measurements and Adjustments</b> -----	<b>55</b>		
12.1. Equipment Required -----	55		
12.2. The Setting Method of JIG -----	55		
12.3. Adjustment Standard (Base Unit)-----	59		
12.4. Adjustment Standard (Charger Unit)-----	60		
12.5. Adjustment Standard (Handset) -----	61		
12.6. Things to Do after Replacing IC or X'tal -----	62		
12.7. Frequency Table -----	64		
12.8. Bluetooth Frequency Table-----	65		
<b>13 Miscellaneous</b> -----	<b>66</b>		
13.1. How to Replace the LLP (Leadless Leadframe Package) IC-----	66		
13.2. How to Replace the Flat Package IC-----	68		
13.3. Terminal Guide of the ICs, Transistors and Diodes -----	70		
<b>14 Schematic Diagram</b> -----	<b>71</b>		
14.1. For Schematic Diagram-----	71		
14.2. Schematic Diagram (Base Unit_Main)-----	72		
14.3. Schematic Diagram (Base Unit_RF)-----	74		
14.4. Schematic Diagram (Base Unit_Operation) -----	75		
14.5. Schematic Diagram (Handset_Main)-----	76		
14.6. Schematic Diagram (Handset_LED)-----	78		
14.7. Schematic Diagram (Charger Unit) -----	79		
<b>15 Printed Circuit Board</b> -----	<b>81</b>		
15.1. Circuit Board (Base Unit_Main)-----	81		

# 1 Safety Precautions

## 1.1. For Service Technicians

- Repair service shall be provided in accordance with repair technology information such as service manual so as to prevent fires, injury or electric shock, which can be caused by improper repair work.

1. When repair services are provided, neither the products nor their parts or members shall be remodeled.
2. If a lead wire assembly is supplied as a repair part, the lead wire assembly shall be replaced.
3. FASTON terminals shall be plugged straight in and unplugged straight out.

- ICs and LSIs are vulnerable to static electricity.

When repairing, the following precautions will help prevent recurring malfunctions.

1. Cover plastic parts boxes with aluminum foil.
2. Ground the soldering irons.
3. Use a conductive mat on worktable.
4. Do not grasp IC or LSI pins with bare fingers.

## 2 Warning

### 2.1. Battery Caution

Risk of explosion if battery is replaced by an incorrect type. Dispose of used batteries according to the instructions.

**Attention:**



A nickel metal hydride battery that is recyclable powers the product you have purchased.

Please call 1-800-8-BATTERY (1-800-822-8837) for information on how to recycle this battery.

### 2.2. About Lead Free Solder (PbF: Pb free)

**Note:**

In the information below, Pb, the symbol for lead in the periodic table of elements, will refer to standard solder or solder that contains lead.

We will use PbF solder when discussing the lead free solder used in our manufacturing process which is made from Tin (Sn), Silver (Ag), and Copper (Cu).

This model, and others like it, manufactured using lead free solder will have PbF stamped on the PCB. For service and repair work we suggest using the same type of solder.

**Caution**

- PbF solder has a melting point that is 50 °F ~ 70 °F (30 °C ~ 40 °C) higher than Pb solder. Please use a soldering iron with temperature control and adjust it to 700 °F ± 20 °F (370 °C ± 10 °C).
- Exercise care while using higher temperature soldering irons.:  
Do not heat the PCB for too long time in order to prevent solder splash or damage to the PCB.
- PbF solder will tend to splash if it is heated much higher than its melting point, approximately 1100 °F (600 °C).
- When applying PbF solder to double layered boards, please check the component side for excess which may flow onto the opposite side (See the figure below).

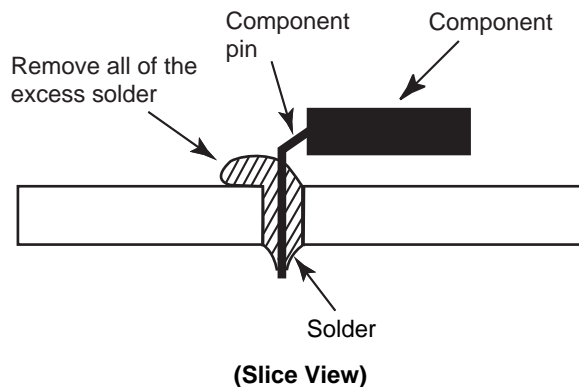

### 2.2.1. Suggested PbF Solder

There are several types of PbF solder available commercially. While this product is manufactured using Tin, Silver, and Copper (Sn+Ag+Cu), you can also use Tin and Copper (Sn+Cu), or Tin, Zinc, and Bismuth (Sn+Zn+Bi). Please check the manufacturer's specific instructions for the melting points of their products and any precautions for using their product with other materials.

The following lead free (PbF) solder wire sizes are recommended for service of this product: 0.3 mm, 0.6 mm and 1.0 mm.

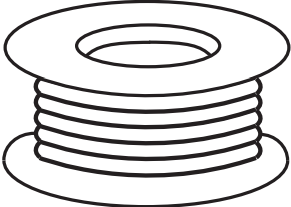
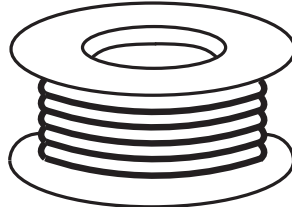
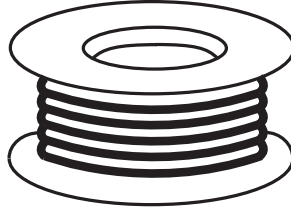
0.3 mm X 100 g	0.6 mm X 100 g	1.0 mm X 100 g
		

### 2.3. Discarding of P. C. Board

When discarding P. C. Board, delete all personal information such as telephone directory and caller list or scrap P. C. Board.

### 3 Specifications

**Standard:**

DECT 6.0 (Digital Enhanced Cordless Telecommunications 6.0)  
Bluetooth wireless technology 2.0

**Number of channels:**

60 Duplex Channels (DECT 6.0)  
79 Duplex channels (Bluetooth)

**Frequency range:**

1.92 GHz to 1.93 GHz (DECT 6.0)  
2.402 GHz to 2.48 GHz (Bluetooth)

**Duplex procedure:**

TDMA (Time Division Multiple Access)

**Channel spacing:**

1.728MHz (DECT 6.0)  
1.0MHz (Bluetooth)

**Bit rate:**

1.152Mbit/s (DECT 6.0)  
1.0 Mbit/s (Bluetooth)

**Modulation:**

GFSK (Gaussian Frequency Shift Keying)

**RF transmission power:**

115 mW (max/DECT6.0)

**Voice coding:**

ADPCM 32 kbit/s (DECT 6.0)  
CVSD/PCM 64kbit/s (Bluetooth)  
PCM 64kbit/s (BT\_IC)

	Base Unit	Handset	Charger
Power source	AC Adaptor (PNLV226Z, 120 V AC, 60 Hz)	Rechargeable Ni-MH battery AAA (R03) size (1.2 V 550 mAh)	AC Adaptor (PNLV226Z, 120 V AC, 60 Hz)
Receiving Method	Super Heterodyne	Super Heterodyne	—
Oscillation Method	PLL synthesizer	PLL synthesizer	—
Detecting Method	Quadrature Discriminator	Quadrature Discriminator	—
Tolerance of OSC Frequency	10.368 MHz ±100 Hz	13.824 MHz ±100 Hz	—
Modulation Method	Frequency Modulation	Frequency Modulation	—
ID Code	40 bit	40 bit	—
Ringer Equivalence No. (REN)	0.1B	—	—
Dialing Mode	Tone (DTMF)/Pulse	Tone (DTMF)/Pulse	—
Redial	Up to 48 digits	Up to 48 digits	—
Speed Dialer	—	Up to 24 digits (Phonebook)	—
Power Consumption	Standby: Approx. 1.2 W Maximum: Approx. 4.5 W	11 days at Standby, 13 hours at Talk	Standby: Approx. 0.1 W Maximum: Approx. 2.0 W
Operating Conditions	0 °C - 40 °C (32 °F - 104 °F) 20 % - 80 % relative air humidity (dry)	0 °C - 40 °C (32 °F - 104 °F) 20 % - 80 % relative air humidity (dry)	0 °C - 40 °C (32 °F - 104 °F) 20 % - 80 % relative air humidity (dry)
Dimensions (W x D x H)	Approx. 200 mm x 119 mm x 71 mm	Approx. 54 mm x 34 mm x 174 mm	Approx. 73 mm x 76 mm x 43 mm
Mass (Weight)	Approx. 350 g	Approx. 150 g	Approx. 50 g

**Note:**

- Design and specifications are subject to change without notice.

**Note for Service:**

- **Operation range:** Up to 300 m outdoors, Up to 50 m indoors, depending on the condition.
- **Analog telephone connection:** Telephone Line
- **Optional headset:** KX-TCA60, KX-TCA93, KX-TCA400, KX-TCA430
- **Optional Range extender:** KX-TGA405

# 4 Technical Descriptions

## 4.1. Circuit Configuration of TG774x Series Phones

TG774x consists of DECT cordless telephone and Bluetooth Module.

Both voices of transmission and reception are transferred by PCM.

BBIC on DECT side controls the cordless telephone system, which makes control data communication with BT\_IC on BT Module in serial data.

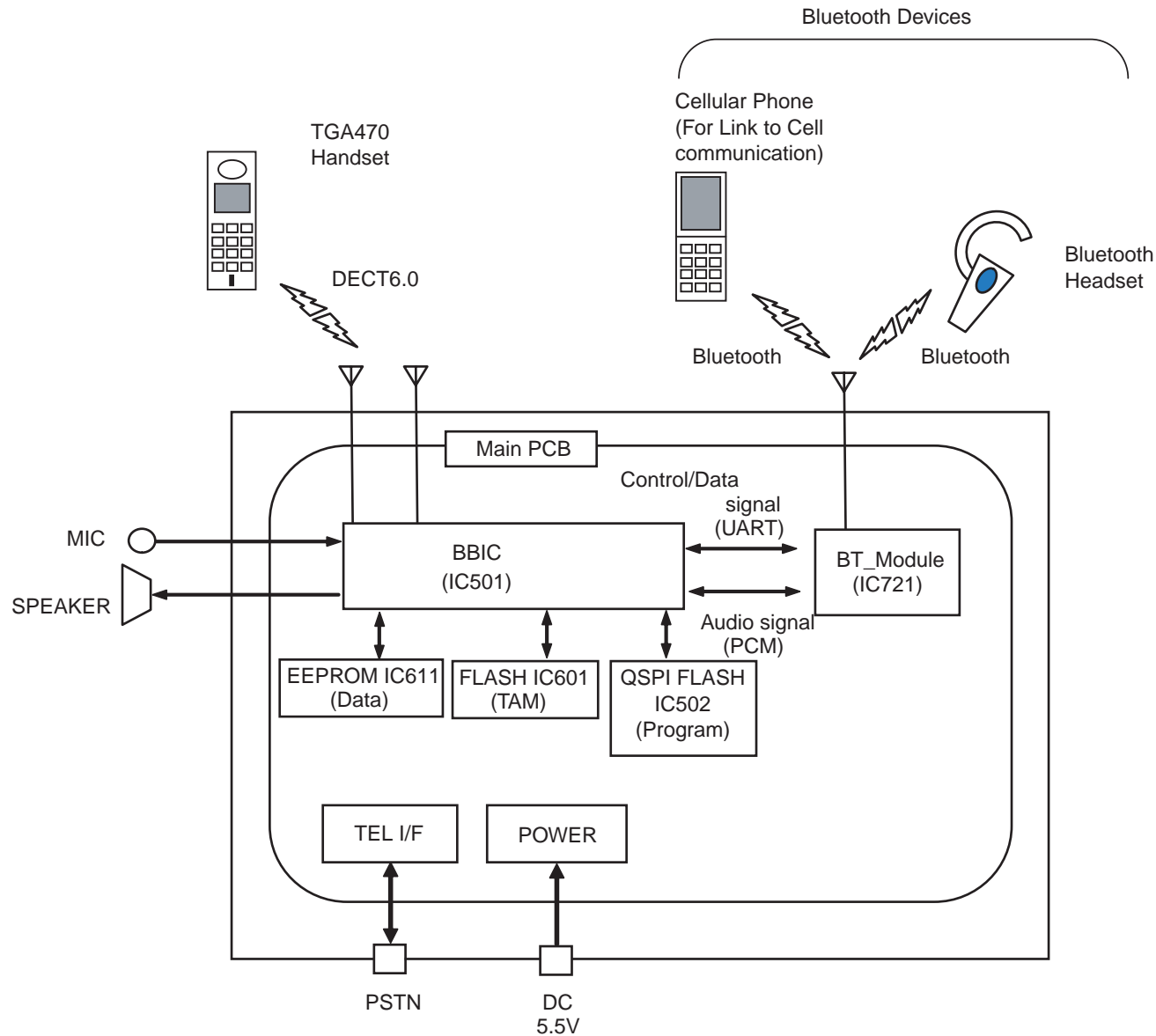

## 4.2. US-DECT Description

The frequency range of 1.92 GHz-1.93 GHz is used. Transmitting and receiving carrier between base unit and handset is same frequency. Refer to **Frequency Table** (P.64).

### 4.2.1. TDD Frame Format

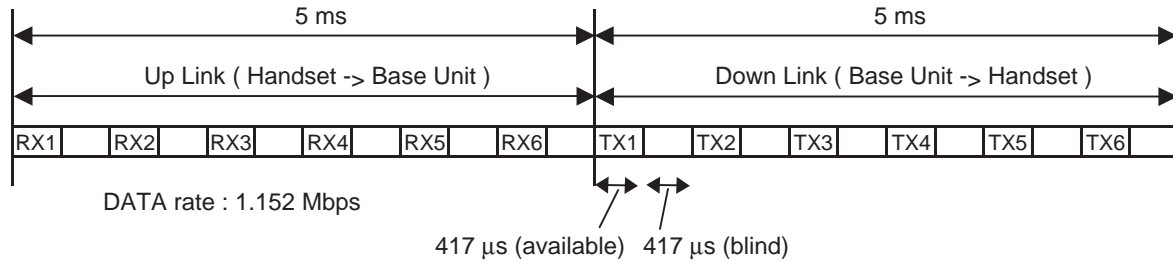

### 4.2.2. TDMA system

This system is the cycles of 10 ms, and has 6 duplex paths, but maximum duplex communication path is 5 because of dummy bearer use.

In 1 slot 417 μs, the 10 ms of voice data is transmitted.

#### • 2 - Handsets Link

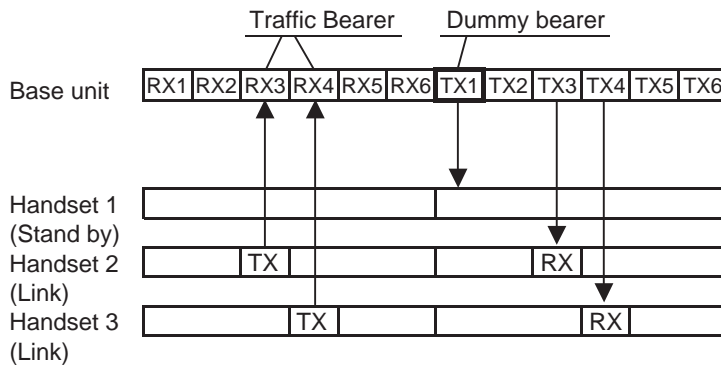

#### Traffic Bearer

A link is established between base unit and handset.

The state where duplex communication is performed.

Handset doesn't make up duplex in no free RF channels because of interference. (\*1)

#### Dummy Bearer

Base unit sends Dummy-data to the all stand-by state handsets.

Handsets receive that data for synchronization and monitoring request from the base unit.

Base unit doesn't send Dummy bearer in no free RF channels because of interference. (\*1)

#### Note:

(\*1) It is a feature under FCC 15 regulation and for interference avoidance.

In the case of checking RF parts, it is better in least interference condition.

### 4.2.3. Signal Flowchart in the Radio Parts

#### Reception

##### Base unit:

A voice signal from TEL line is encoded to digital data and converted into a 1.9GHz modulated radio signal by BBIC(IC501). The RF signal, after which is amplified in BBIC, is fed to selected antenna.

##### Handset:

As for a handset RF, RF signal is received in one antenna.

BBIC down-converts to 864 kHz IF signal from RX signal and demodulates it to digital data "RXDATA".

BBIC (IC1) converts RXDATA into a voice signal and outputs it to speaker.

#### Transmission

##### Handset:

A voice signal from microphone is encoded to digital data and converted into a 1.9GHz modulated radio signal by BBIC(IC1). The RF signal, after which is amplified in BBIC, is fed to an antenna.

##### Base unit:

As for a base unit RF, RF signal is received in two antennas.

BBIC (IC501) compares RF signal levels and selects the antenna to be used. Then BBIC down-converts to 864 kHz IF signal from RX signal in the selected antenna, and demodulates it to digital data "RXDATA".

BBIC (IC501) converts RXDATA into a voice signal and outputs it to TEL line.

### 4.3. Block Diagram (Base Unit\_Main)

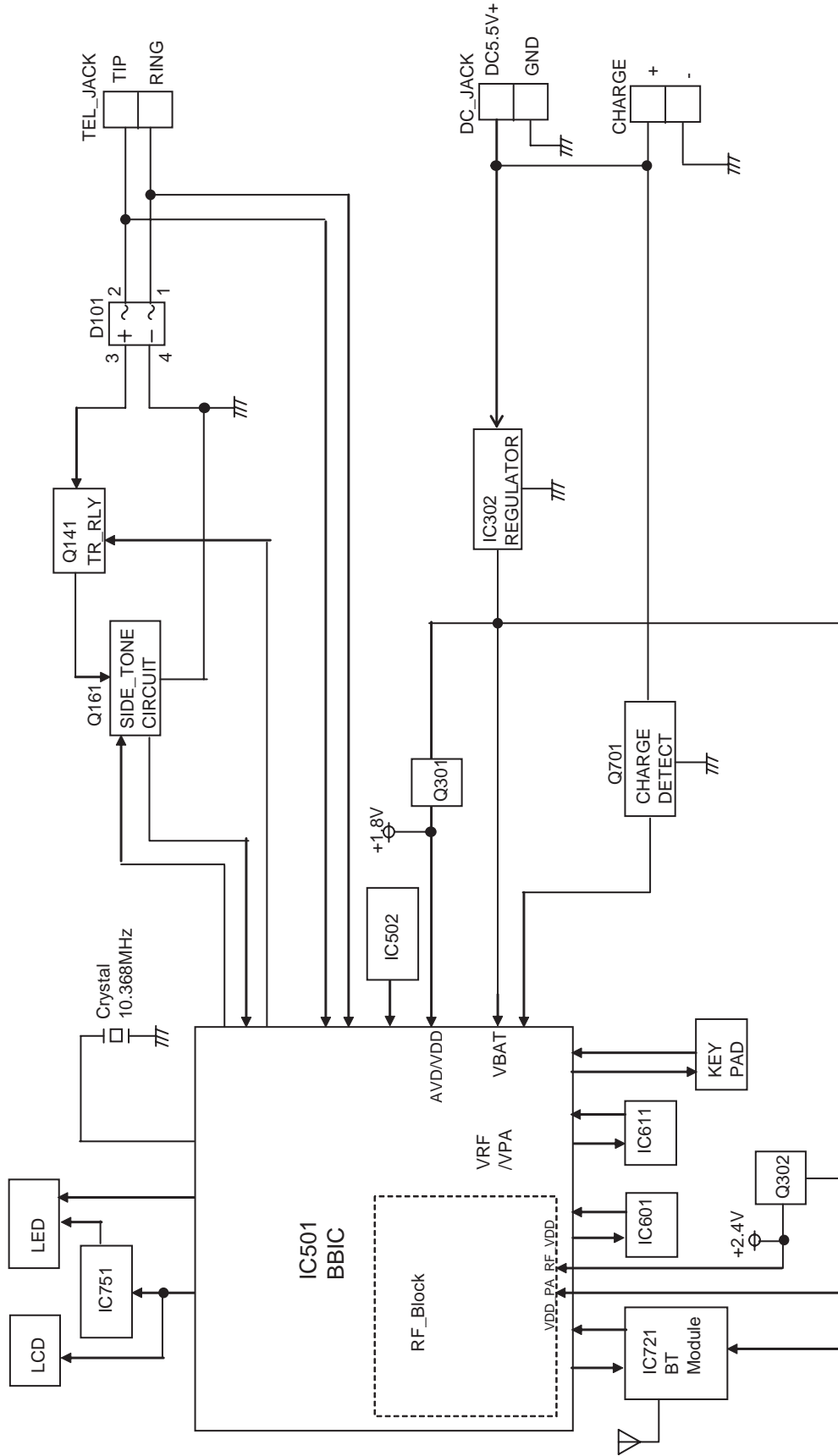

KX-TG7741/7742/7743 BLOCK DIAGRAM (Base Unit\_Main)



### 4.5. Block Diagram (Base Unit\_RF Part)

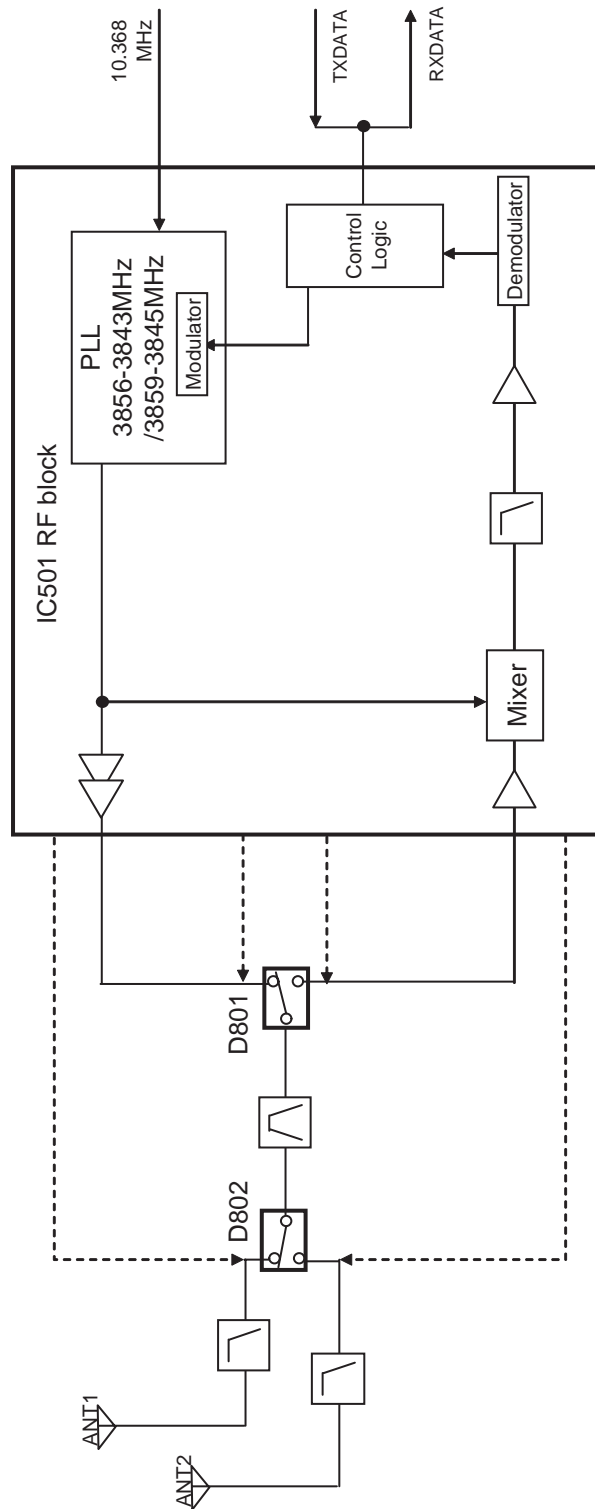

KX-TG7741/7742/7743 BLOCK DIAGRAM (Base Unit\_RF Part)

## 4.6. Circuit Operation (Base Unit)

### General Description:

(BBIC, Flash Memory, EEPROM) is a digital speech/signal processing system that implements all the functions of speech compression, record and playback, and memory management required in a digital telephone answering machine.

The BBIC system is fully controlled by a host processor. The host processor provides activation and control of all that functions as follows.

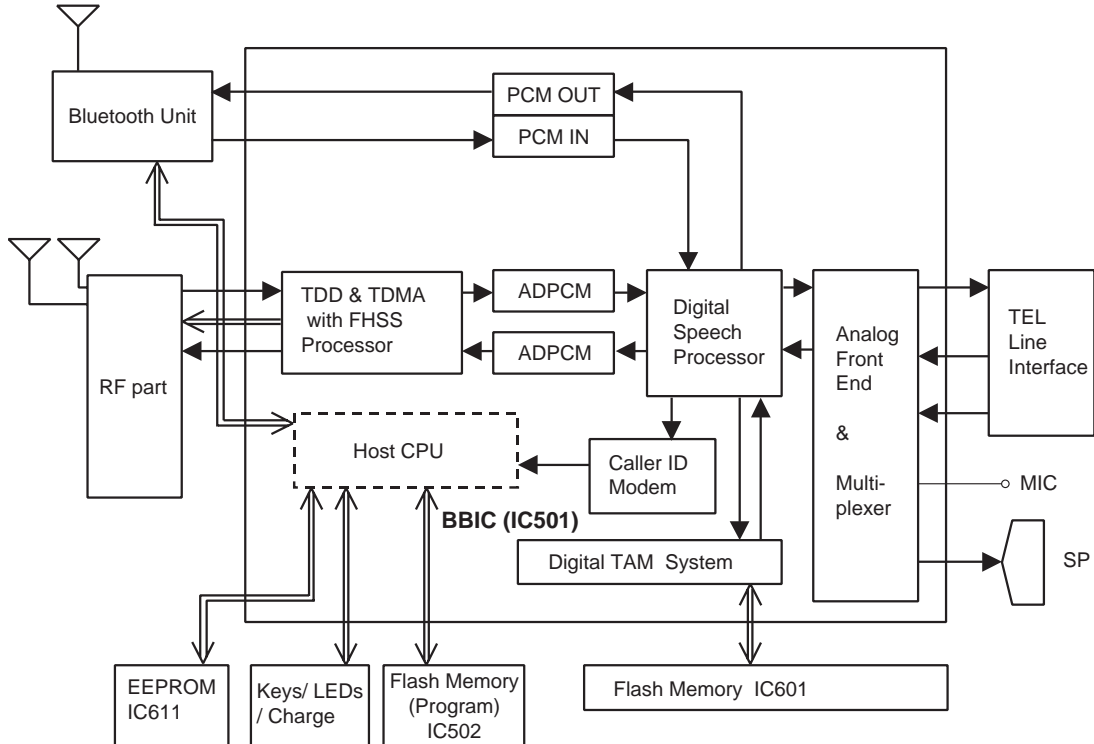

### 4.6.1. BBIC (Base Band IC: IC501)

- **Voice Message Recording/Play back**

The BBIC system uses a proprietary speech compression technique to record and store voice message in Flash Memory. An error correction algorithm is used to enable playback of these messages from the Flash Memory.

- **DTMF Generator**

When the DTMF data from the handset is received, the DTMF signal is output.

- **Synthesized Voice (Pre-recorded message)**

The BBIC implements synthesized Voice, utilizing the built in speech detector and a Flash Memory, which stored the vocabulary.

- **Caller ID demodulation**

The BBIC implements monitor and demodulate the FSK/DTMF signals that provide CID information from the Central Office.

- **Digital Switching**

The voice signal from telephone line is transmitted to the handset or the voice signal from the handset is transmitted to the Telephone line, etc. They are determined by the signal path route operation of voice signal.

- **Block Interface Circuit**

RF part, LED, Key scan, Speaker, Telephone line.

### 4.6.2. Flash Memory (IC502)

Main program data is stored.

### 4.6.3. Flash Memory (IC601)

Following information data is stored.

- **Voice signal**

ex: Pre-recorded Greeting message, Incoming message

### 4.6.4. EEPROM (IC611)

Following information data is stored.

- **Settings**

ex: message numbers, ID code, Flash Time, Tone/Pulse

### 4.6.5. Bluetooth Unit (IC721)

Use for Bluetooth communication.

### 4.6.6. Power Supply Circuit/Reset Circuit

The power supply voltage from AC adaptor is converted to VBAT (3.0V) in IC302. And +3.0V for peripherals and analog part is insulated from VBAT by Doubler of BBIC.

**Circuit Operation:**

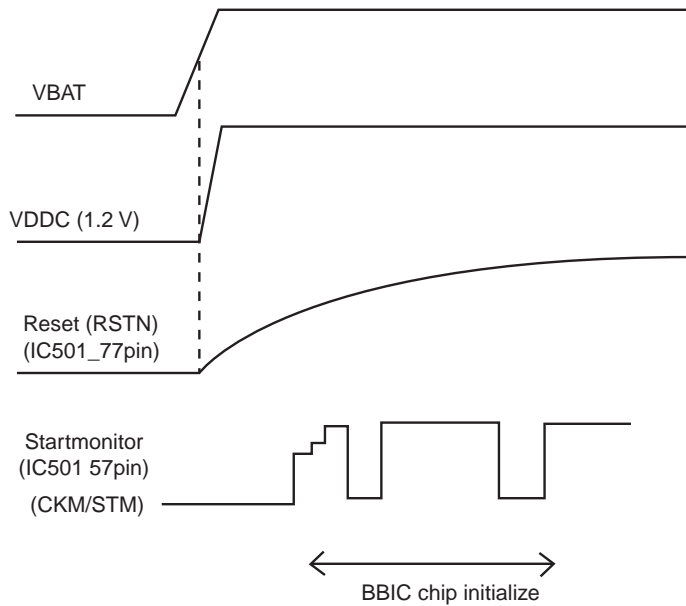
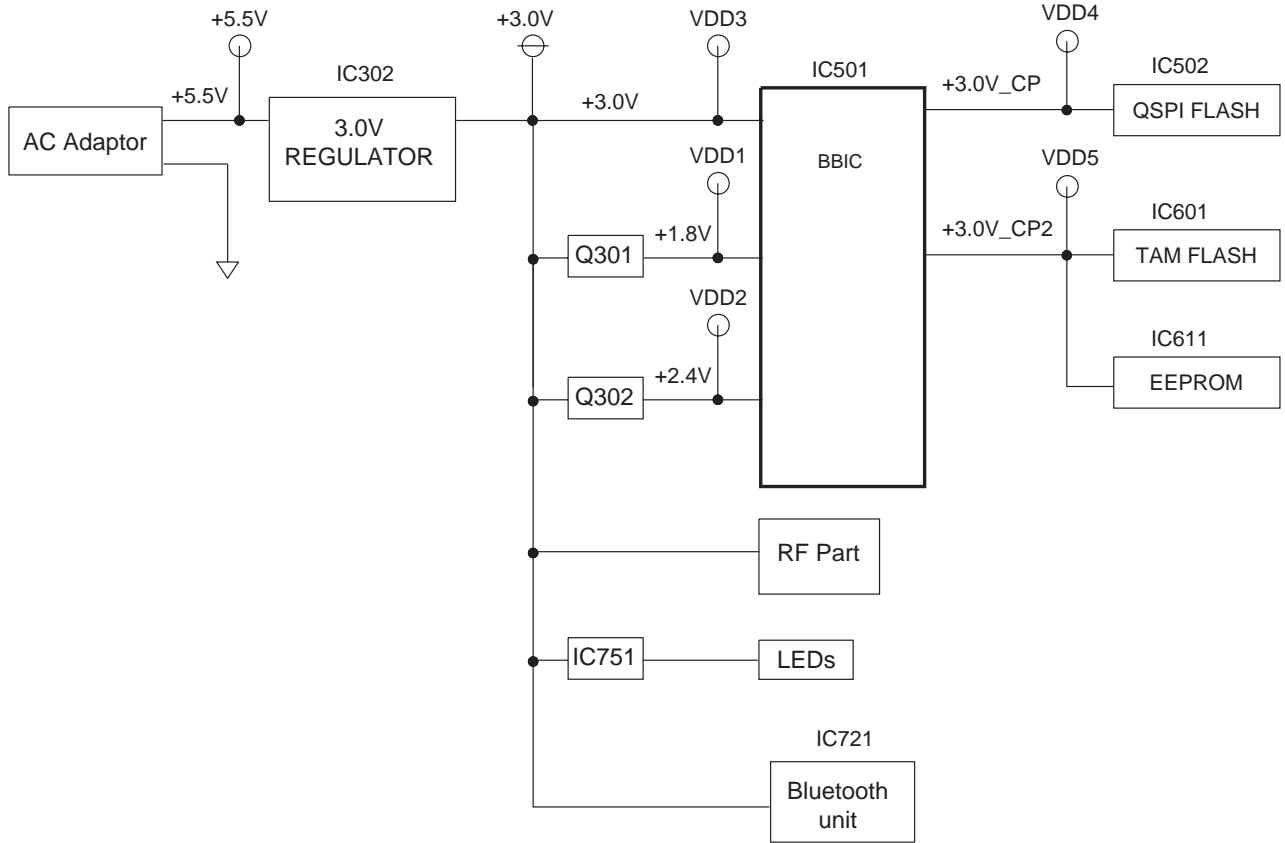

### 4.6.6.1. Charge Circuit

The voltage from the AC adaptor is supplied to the charge circuits.

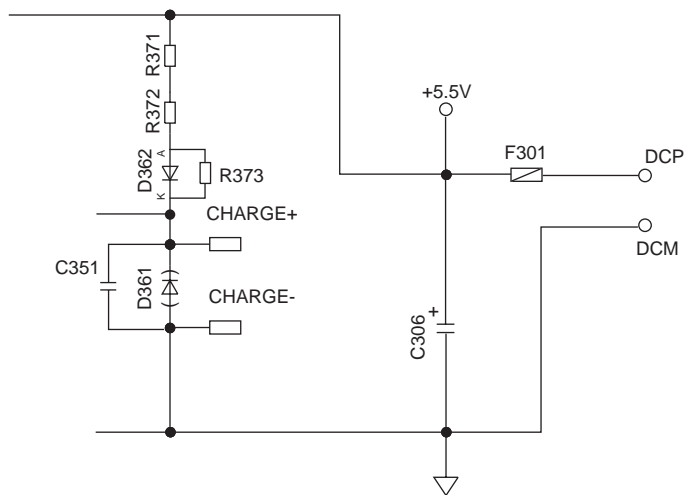

### 4.6.7. Telephone Line Interface

#### Telephone Line Interface Circuit:

##### Function

- Bell signal detection
- ON/OFF hook and pulse dial circuit
- Side tone circuit

##### Bell (RINGING) signal detection and OFF HOOK circuit:

In the idle mode, Q141 is open to cut the DC loop current and decrease the ring load. When ring voltage appears at the Tip (T) and Ring (R) leads (When the telephone rings), the AC ring voltage is transferred as follows:

L1T→L101→C105→R105→R110→R111→R112→BBIC pin18(RINGING)

When the CPU (BBIC) detects a ring signal, Q141 turns on, thus providing an off-hook condition (active DC current flow through the circuit). Following signal flow is the DC current flow.

T → L101 → D101 → Q141 → Q161 → R163 → R167 → D101 → L102 → P101 → R

##### ON HOOK Circuit:

Q141 is open, Q141 is connected as to cut the DC loop current and to cut the voice signal. The unit is consequently in an on-hook condition.

##### Pulse Dial Circuit:

Pin 19 of BBIC turns Q141 ON/OFF to make the pulse dialing.

##### Side Tone Circuit:

Basically this circuit prevents the TX signal from feeding back to RX signal. As for this unit, TX signal feed back from Q161 is canceled by the canceller circuit of BBIC.

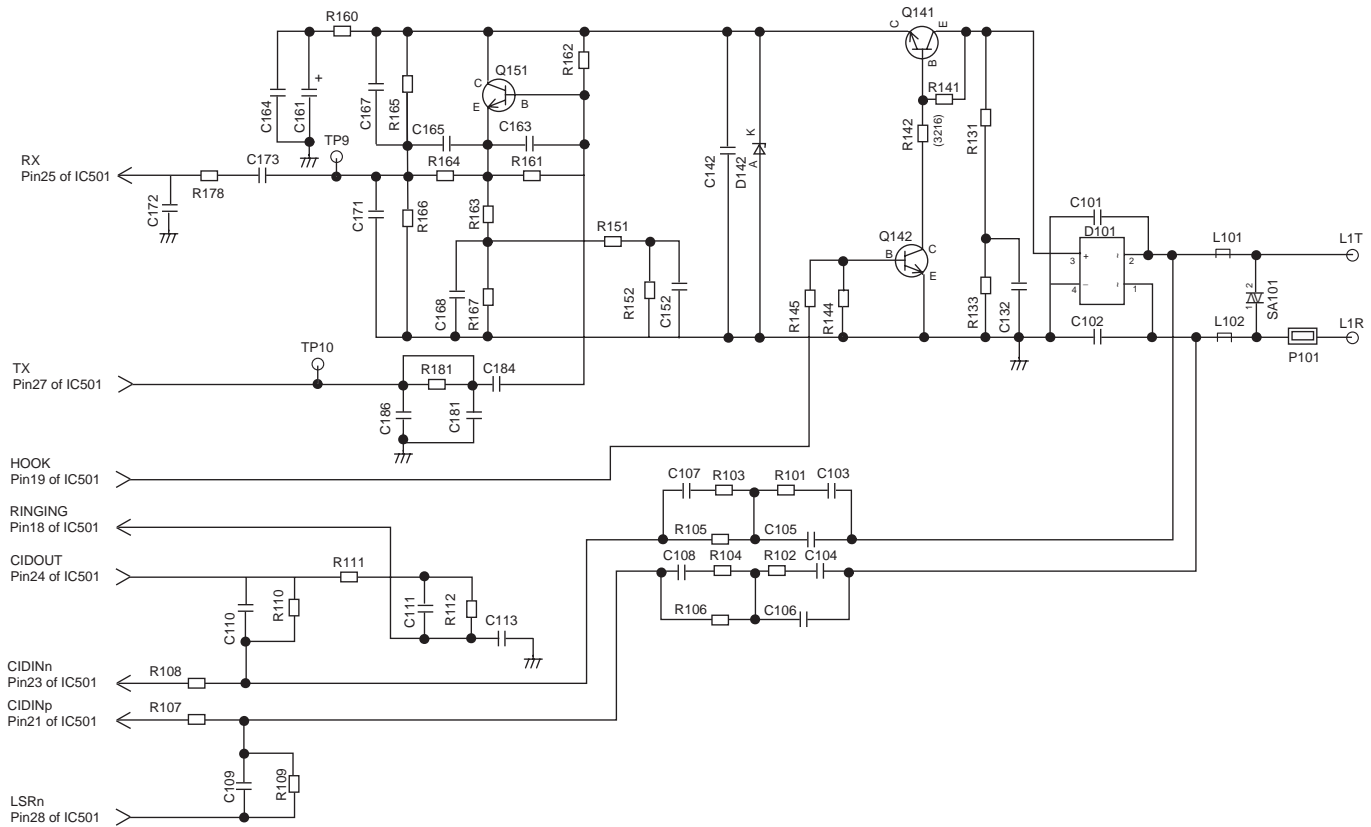

#### 4.6.8. Parallel Connection Detect Circuit/Auto Disconnect Circuit

##### Function:

In order to disable call waiting and stutter tone functions when using telephones connected in parallel, it is necessary to have a circuit that judges whether a telephone connected in parallel is in use or not. This circuit determines whether the telephone connected in parallel is on hook or off hook by detecting changes in the T/R voltage.

##### Circuit Operation:

Parallel connection detection when on hook:

When on hook, the voltage is monitored at pin 32 of IC501. There is no parallel connection if the voltage is 0.54 V or higher, while a parallel connection is deemed to exist if the voltage is lower.

Parallel connection detection when off hook:

When off hook, the voltage is monitored at pin 17 of IC501; the presence/absence of a parallel connection is determined by detecting the voltage changes.

If the Auto disconnect function is ON and statuses are Hold, receiving ICM, OGM transmitting, BBIC disconnects the line after detecting parallel connection is off hook.

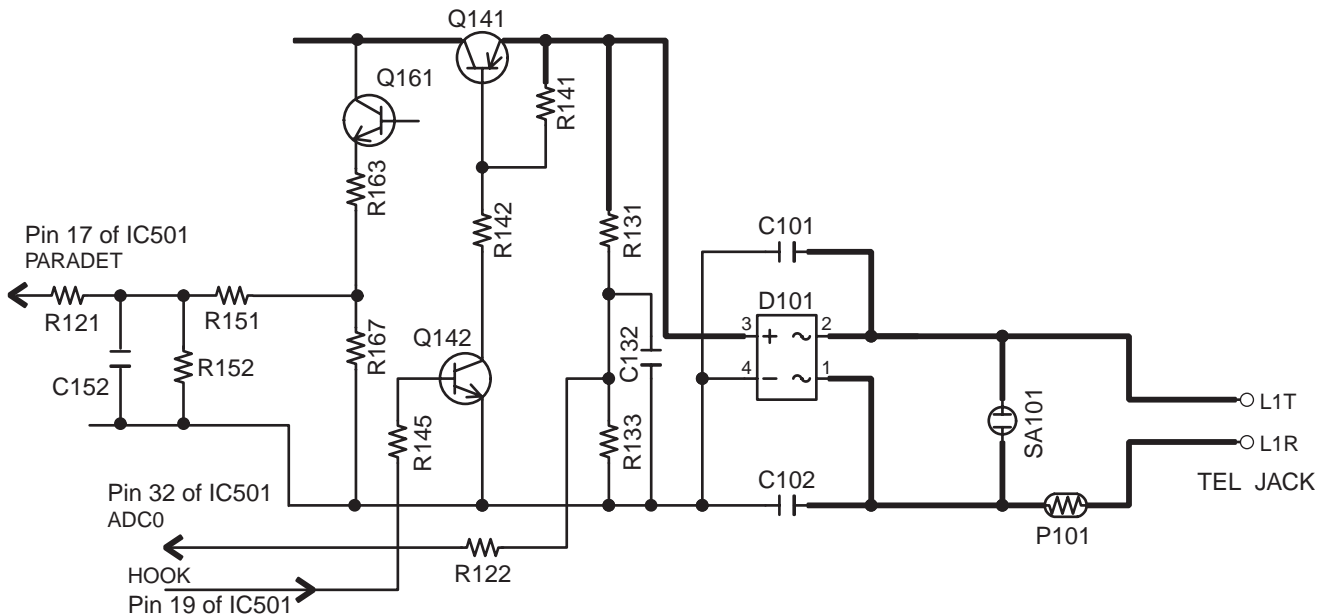

### 4.6.9. Calling Line Identification (Caller ID)/Call Waiting Caller ID

**Function:**

**Caller ID**

The caller ID is a chargeable ID which the user of a telephone circuit obtains by entering a contract with the telephone company to utilize a caller ID service. For this reason, the operation of this circuit assumes that a caller ID service contract has been entered for the circuit being used. The data for the caller ID from the telephone exchange is sent during the interval between the first and second rings of the bell signal. The data from the telephone exchange is a modem signal which is modulated in an FSK (Frequency Shift Keying) \* format. Data "1" is a 1200 Hz sine wave, and data "0" is a 2200 Hz sine wave. There are two types of the message format which can be received: i.e. the single message format and plural message format. The plural message format allows to transmit the name and data code information in addition to the time and telephone number data.

\*: Also the telephone exchange service provides other formats.

- Single message format

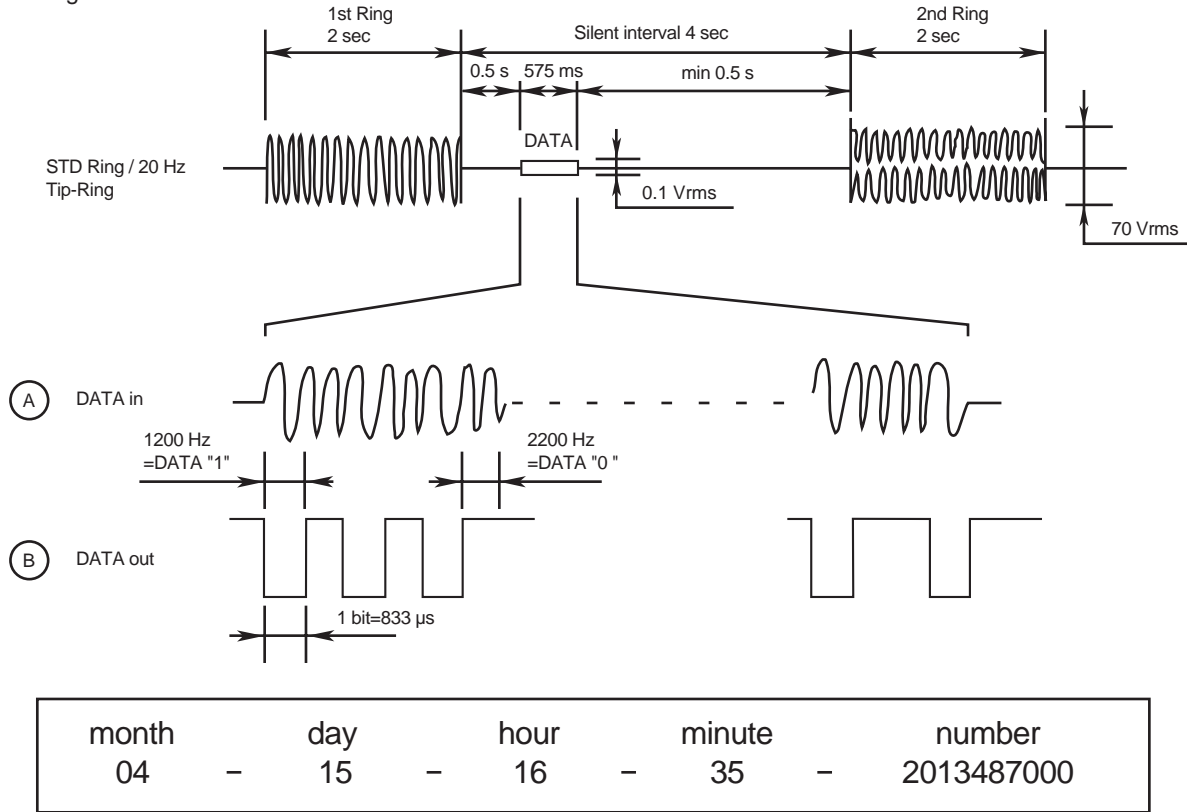

- Plural message format

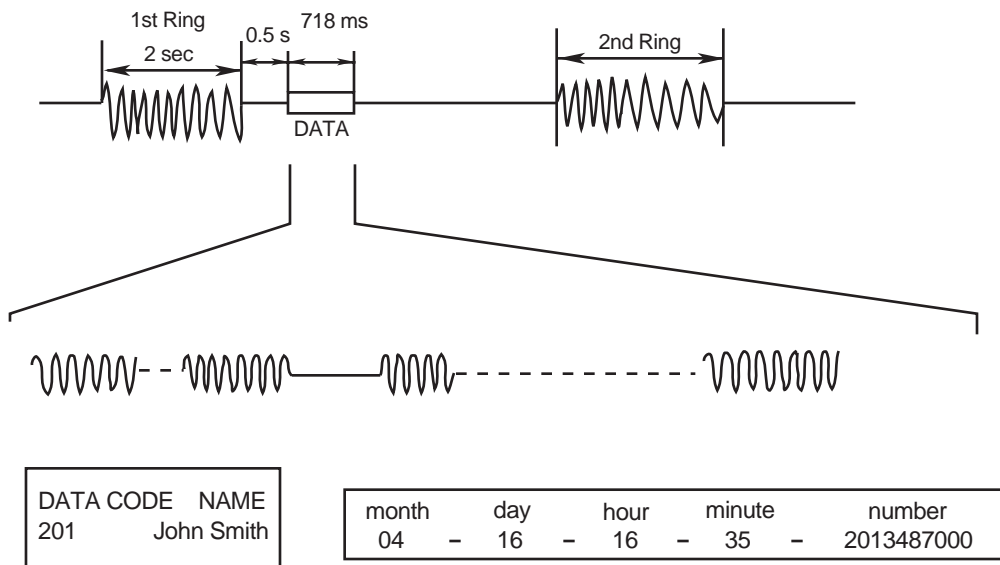

### Call Waiting Caller ID

Calling Identity Delivery on Call Waiting (CIDCW) is a CLASS service that allows a customer, while off-hook on an existing call, to receive information about a calling party on a waited call. The transmission of the calling information takes place almost immediately after the customer is alerted to the new call so he/she can use this information to decide whether to take the new call.

### Function:

The telephone exchange transmits or receives CAS and ACK signals through each voice RX/TX route. Then FSK data and MARK data pass the following route.

Telephone Line→P101→L101, L102→C105, C106→R105, R106→R108, R107→IC501(23, 21).

If the unit deems that a telephone connected in parallel is in use, ACK is not returned even if CAS is received, and the information for the second and subsequent callers is not displayed on the portable handset display.

### Call Waiting Format

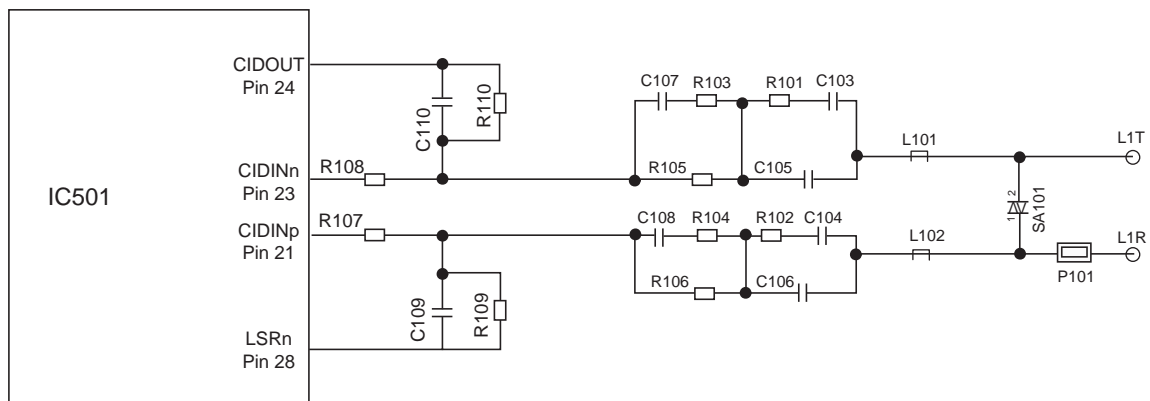
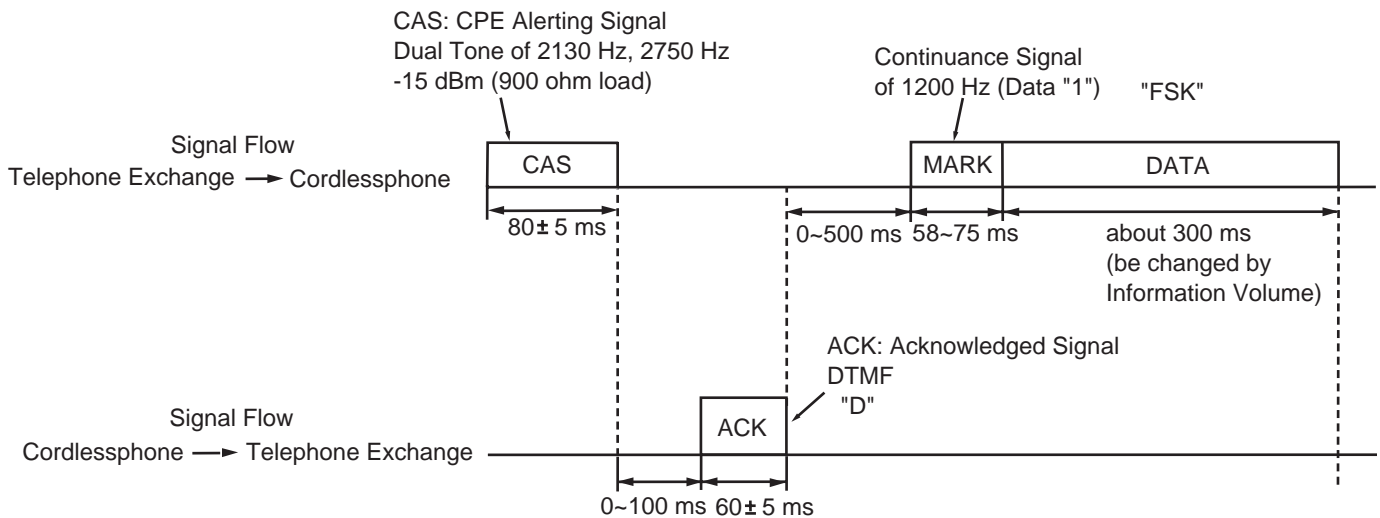

### 4.7. Block Diagram (Handset)

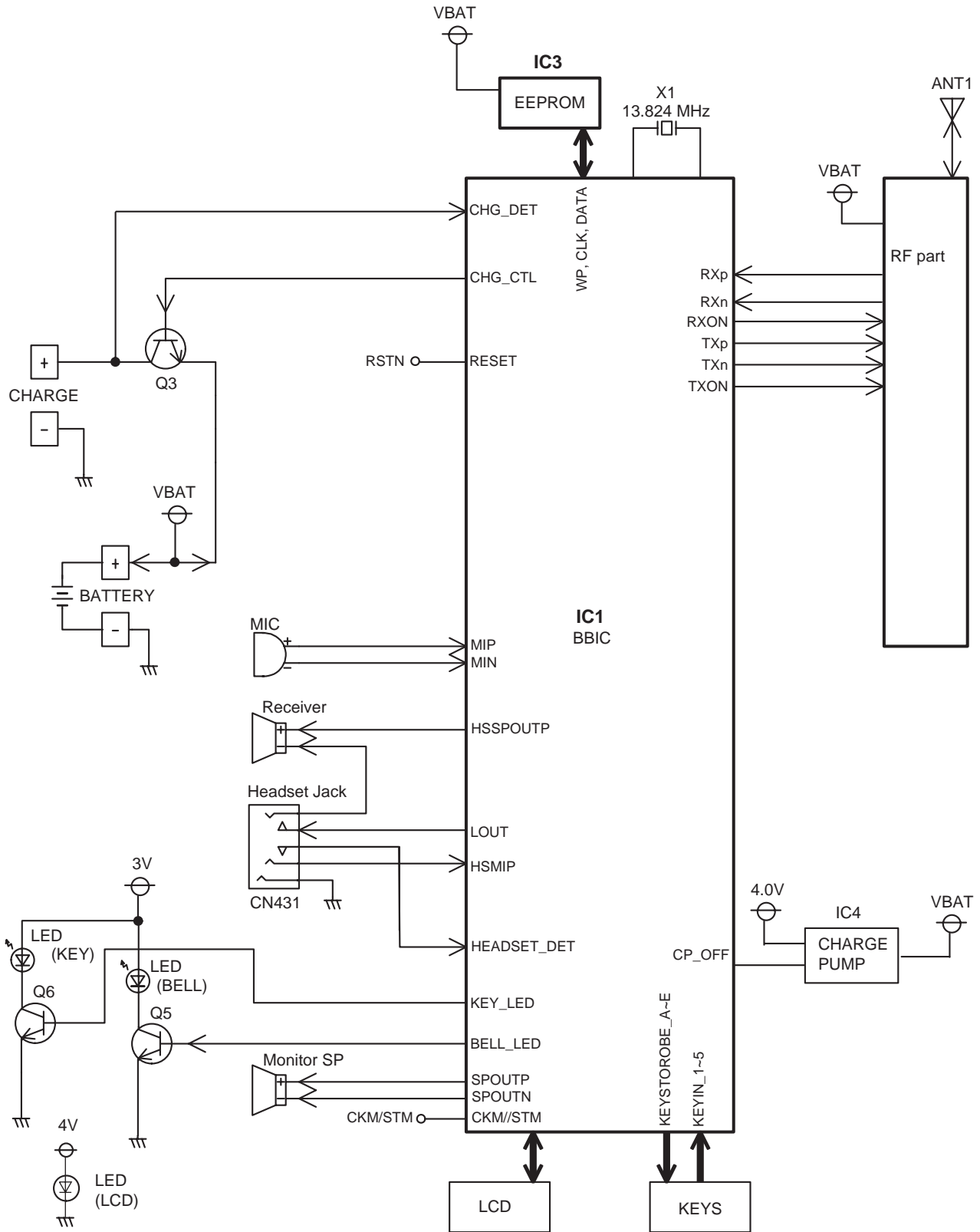

KX-TGA470 BLOCK DIAGRAM (Handset)

### 4.8. Block Diagram (Handset\_RF Part)

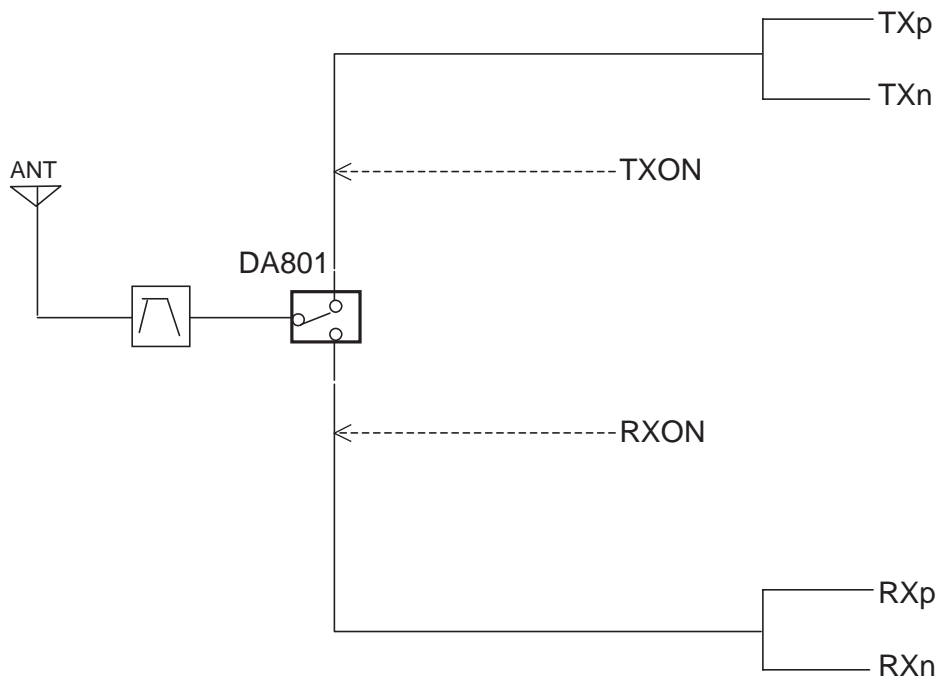

KX-TGA470 BLOCK DIAGRAM (Handset\_RF Part)

## 4.9. Circuit Operation (Handset)

### 4.9.1. Outline

Handset consists of the following ICs as shown in **Block Diagram (Handset)** (P.20).

- DECT BBIC (**B**ase **B**and IC): IC1
  - All data signals (forming/analyzing ACK or CMD signal)
  - All interfaces (ex: Key, Detector Circuit, Charge, EEPROM, LCD)
- EEPROM: IC3
  - Setting data is stored. (e.g. ID, user setting)

### 4.9.2. Power Supply Circuit/Reset Circuit

#### Circuit Operation:

When power on the Handset, the voltage is as follows;  
 BATTERY(2.2 V ~ 2.6 V: BATT+) → F1 → BBC1 (IC1) 10 pin  
 The Reset signal generates IC1 (54 pin) and 1.8 V.

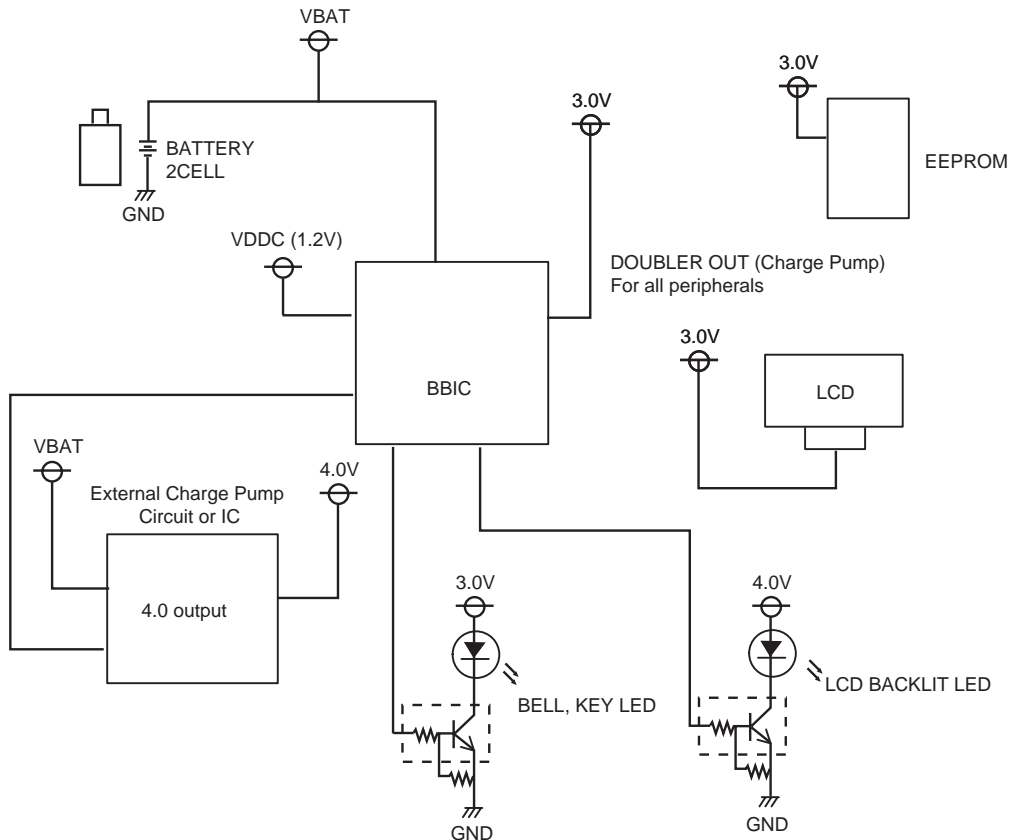
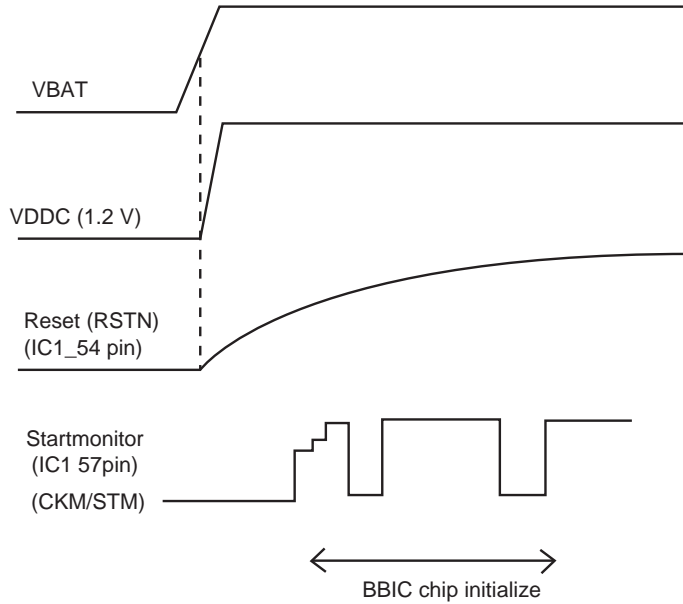

### 4.9.3. Charge Circuit

**Circuit Operation:**

When charging the handset on the Base Unit, the charge current is as follows;  
 DC+(6.5 V) → F301 → R371 → R372 → CHARGE+(Base) → CHARGE+(Handset) → Q4 → D7 → F1 → BATTERY+... Battery...  
 BATTERY- → R45 → GND → CHARGE-(Handset) → CHARGE-(Base) → GND → DC-(GND)  
 In this way, the BBIC on Handset detects the fact that the battery is charged.  
 The charge current is controlled by switching Q9 of Handset.  
 Refer to Fig.101 in **Power Supply Circuit/Reset Circuit** (P.14).

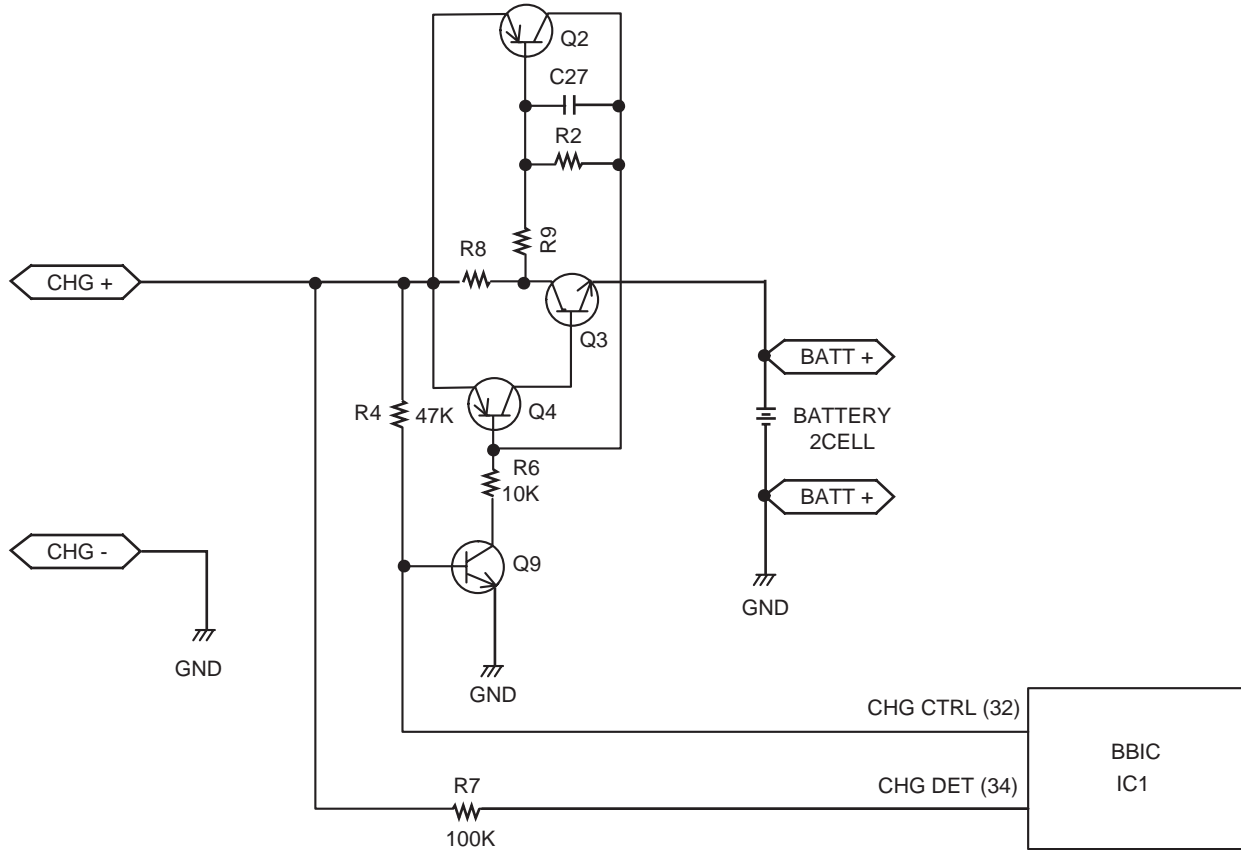

### 4.9.4. Battery Low/Power Down Detector

**Circuit Operation:**

“Battery Low” and “Power Down” are detected by BBIC which check the voltage from battery.  
 The detected voltage is as follows;

- Battery Low  
 Battery voltage:  $V(\text{Batt}) \leq 2.35 \text{ V} \pm 50 \text{ mV}$   
 The BBIC detects this level and "█" starts flashing.
- Power Down  
 Battery voltage:  $V(\text{Batt}) \leq 2.1 \text{ V} \pm 50 \text{ mV}$   
 The BBIC detects this level and power down.

### 4.9.5. Speakerphone

The hands-free loudspeaker at SP+ and SP- is used to generate the ring alarm.

### 4.10. Circuit Operation (Charger Unit)

Charge control is executed at handset side so that the operation when using charger is also controlled by handset.  
 Refer to **Circuit Operation (Handset)** (P.22)

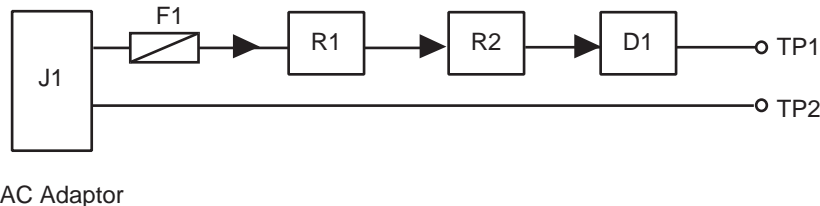

The route for this is as follows: DC+pin of J1(+) → F1 → R1 → CHARGE+pad → Handset → CHARGE-pad → DC-pin of J1(-).

## 4.11. Signal Route

SIGNAL ROUTE	IN	→	ROUTE	→	OUT
HANDSET TX			HANDSET MIC - R73/74 - C11/13 - RA4 - IC1(22/23) - <HANDSET_RF_TX_ROUTE> - ANT. ---		
			ANT. - <BASE_UNIT_RF_RX_ROUTE> - IC501(2/3 - 27) - C184 - Q161 -Q141 - D101 - L101/[L102-P101] - T/R (TEL LINE)		
HANDSET RX			T/R (TEL LINE) - L101/[P101-L102] - D101 - Q141 - R165 - C173 - R178 - IC501(25 - 94/95) - <BASE_UNIT_RF_TX_ROUTE> - ANT		
			--- ANT. - <HANDSET_RF_RX_ROUTE> - IC1(28/27) - C86 - L74 - HEADSET_JACK(5 - 4) - R11 - HANDSET SPEAKER		
HEADSET TX			HEADSET_JACK(2) - R306 - C14 - R22 - IC1(25) - <HANDSET_RF_TX_ROUTE> - ANT. ---		
			ANT. - <BASE_UNIT_RF_RX_ROUTE> - IC501(2/3 - 27) - C184 - Q161 -Q141 - D101 - L101/[L102-P101] - T/R (TEL LINE)		
HEADSET RX			T/R (TEL LINE) - L101/[P101-L102] - D101 - Q141 - R165 - C173 - R178 - IC501(25 - 94/95) - <BASE_UNIT_RF_TX_ROUTE> - ANT		
			--- ANT. - <HANDSET_RF_RX_ROUTE> - IC1(28) - C86 - L74 - HEADSET_JACK(5)		
HANDSET SP-Phone TX			HANDSET MIC - R73/74 - C11/13 - RA4 - IC1(22/23) - <HANDSET_RF_TX_ROUTE> - ANT. ---		
			ANT. - <BASE_UNIT_RF_RX_ROUTE> - IC501(2/3 - 27) - C184 - Q161 -Q141 - D101 - L101/[L102-P101] - T/R (TEL LINE)		
HANDSET SP-Phone RX			T/R (TEL LINE) - L101/[P101-L102] - D101 - Q141 - R165 - C173 - R178 - IC501(25 - 94/95) - <BASE_UNIT_RF_TX_ROUTE> - ANT		
			--- ANT. - <HANDSET_RF_RX_ROUTE> - IC1(29/31) - Backside SP		
BASE SP-Phone TX			MIC - C457/C458 - RA452 - IC501(37/38 - 27) - C184 - Q161 -Q141 - D101 - L101/[L102-P101] - T/R (TEL LINE)		
BASE SP-Phone RX			T/R (TEL LINE) - L101/[P101-L102] - D101 - Q141 - R165 - C173 - R178 - IC501(25 - 41/43) - SPEAKER		
CELLULAR TX			HANDSET MIC - R73/74 - C11/13 - RA4 - IC1(22/23) - <HANDSET_RF_TX_ROUTE> - ANT. ---		
			ANT. - <BASE_UNIT_RF_RX_ROUTE> - IC501(2/3 - 80) - IC721(31 - 19) - R781 - ANT_BT - CELL PHONE		
CELLULAR RX			CELL PHONE - ANT_BT - R781 - IC721(19 - 3) - IC501(81 - 94/95) - <BASE_UNIT_RF_TX_ROUTE> - ANT		
			---ANT.- <HANDSET_RF_RX_ROUTE> - IC1(28/27) - C86 - L74 - HEADSET JACK(5-4) - R11- HANDSET SPEAKER		
Bluetooth Headset Sound TX(to Tel Line)			from BT Headset - ANT_BT - R781 - IC721(19 - 3) - IC501(81 - 27) - C184 - Q161 -Q141 - D101 - L101/[L102-P101] - T/R (TEL LINE)		
Bluetooth Headset Sound RX(from Tel Line)			T/R (TEL LINE) - L101/[P101-L102] - D101 - Q141 - R165 - C173 - R178 - IC501(25 - 80) - IC721(31 - 19) - R781 - ANT_BT - to BT Headset		

**Note:**

: inside of Handset

**RF part signal route**

SIGNAL ROUTE	IN	→	ROUTE	→	OUT
INTERCOM HANDSET TO BASE UNIT	HANDSET MIC - R73/74 - C11/13 - RA4 - IC1(22/23) - <HANDSET_RF_TX_ROUTE> - ANT. --- ANT - <BASE_UNIT_RF_RX_ROUTE> - IC501(2/3 - 41/43) - SPEAKER				
INTERCOM BASE UNIT TO HANDSET	MIC - C457/C458 - RA452 - IC501(37/38 - 94/95) - <BASE_UNIT_RF_TX_ROUTE> - ANT --- ANT. - <HANDSET_RF_RX_ROUTE> - IC1(28/27) - C86 - L74 - HEADSET_JACK(5 - 4) - R11 - HANDSET SPEAKER				
GREETING RECORDING	HANDSET MIC - R73/74 - C11/13 - RA4 - IC1(22/23) - <HANDSET_RF_TX_ROUTE> - ANT. --- ANT - <BASE_UNIT_RF_RX_ROUTE> - IC501(2/3 - 69/70) - IC601				
GREETING PLAY TO TEL LINE	IC601 - IC501(69/70 - 27) - C184 - Q161 - Q141 - D101 - L101/[L102-P101] - T/R (TEL LINE)				
ICM RECORDING	T/R (TEL LINE) - L101/[P101-L102] - D101 - Q141 - R165 - C173 - R178 - IC501(25 - 69/70) - IC601				
ICM PLAY TO SPEAKER	IC601 - IC501(69/70 - 41/43) - SPEAKER				
DTMF SIGNAL TO TEL LINE	IC501(27) - C184 - Q161 - Q141 - D101 - L101/[L102-P101] - T/R (TEL LINE)				
CALLER ID	T/R(TEL LINE) - L101/[P101 - L102] - C105/C106 - R105/R106 - R108/R107 - IC501(23/21)				
BELL DETECTION	T/R(TEL LINE) - L101 - C105 - R105 - R110 - R111 - R112 - IC501(18)				
<b>HANDSET RF [ TX_ROUTE ]</b>	IC1(44/45) - L809 - C812 - DA801 - C803 - C801 - ANT				
<b>HANDSET RF [ RX_ROUTE ]</b>	ANT - C801 - C803 - DA801 - C826 - IC1(46/47)				
<b>BASE UNIT RF [ TX_ROUTE ]</b>	IC501(95/94) - L802/C813 - C812 - DA801 - C803 - DA802 - C851/C853 - ANT1/ANT2				
<b>BASE UNIT RF [ RX_ROUTE ]</b>	ANT1/ANT2 - C851/C853 - DA802 - C803 - DA801 - C826 - C854/C853 - IC501(3/2)				

**Note:**

 : inside of Handset

## 5 Location of Controls and Components

Refer to the Operating Instructions.

**Note:**

You can download and refer to the Operating Instructions (Instruction book) on TSN Server.

## 6 Installation Instructions

Refer to the Operating Instructions.

**Note:**

You can download and refer to the Operating Instructions (Instruction book) on TSN Server.

## 7 Operating Instructions

Refer to the Operating Instructions.

**Note:**

You can download and refer to the Operating Instructions (Instruction book) on TSN Server.

# 8 Test Mode

## 8.1. Engineering Mode

### 8.1.1. Base Unit

#### Important:

Make sure the address on LCD is correct when entering new data. Otherwise, you may ruin the unit.

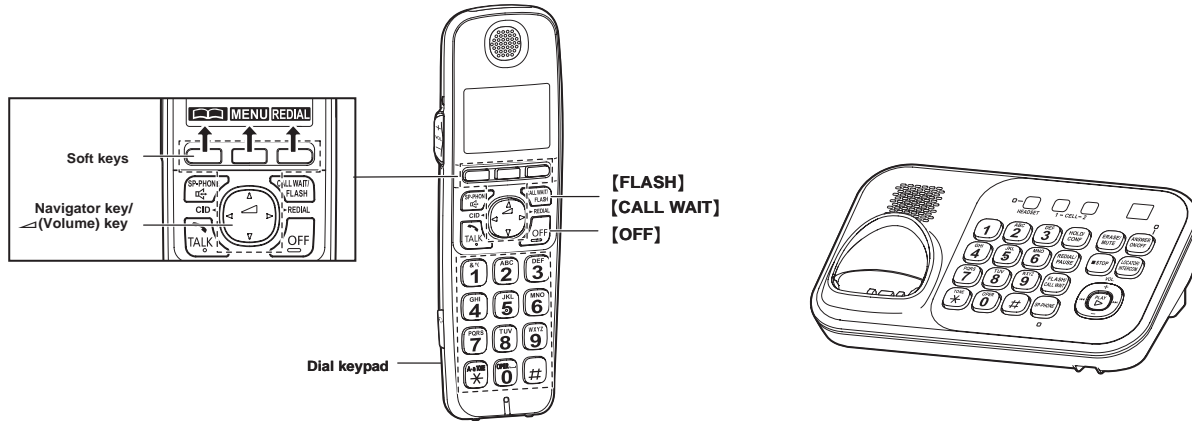

#### H/S key operation

- 1). Press **MENU** .
- 2). Select "Initial Setting" using **[▲]** or **[▼]** then press **SELECT** or **[▶]**.  
  
 Select "Set tel line" using **[▲]** or **[▼]** then press **SELECT** or **[▶]**.
- 3). Enter "7", "2", "6", "2", "7", "6", "6", "4".  
**Note:** 7262 7664 = PANA SONI  
 (see letters printed on dial keys)
- 4). Select "Write EEP" using **[▲]** or **[▼]** then press **SELECT** or **[▶]**.
- 5). Enter "●", "●", "●", "●" (Address). (\*1)
- 6). Enter "\* ", "\* " (New Data). (\*1)

#### H/S LCD

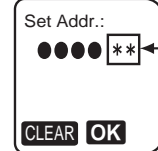
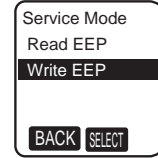
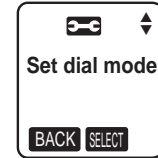
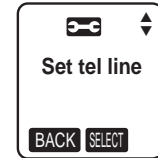
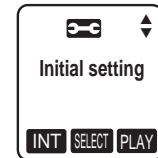

See next page

7). Press **OK** , a long confirmation beep will be heard.

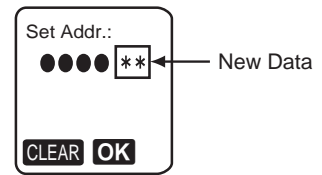

8). Press **[OFF]** to return to standby mode.  
After that, turn the base unit power off and then power on.



Note: \* To enter "Set dial mode", press **SELECT** or **[▶]** at " Set tel line".  
It is necessary to turn on the power of base unit.

\* "Set tel line" isn't appeared at Cell line only mode.  
To back normal mode, execute the following procedure:

- 1 **[MENU]** → **[#][1][5][7]**
- 2 **[▼]/[▲]**: Select "off " → **[SELECT]**
- 3 **[OFF]**

**Frequently Used Items (Base Unit)**

ex.)

Items	Address	Default Data	New Data		Remarks
Frequency	00 07 / 00 08	70/02	-	-	Use these items in a <b>READ-ONLY</b> mode to confirm the contents. Careless rewriting may cause serious damage to the computer system.
ID	00 02 ~ 00 06	Given value	-	-	

**Note:**

(\*1) When you enter the address or New Data, please refer to the table below.

Desired Number (hex)	Input Keys	Desired Number (hex)	Input Keys
0	0	A	[Flash] + 0
1	1	B	[Flash] + 1
.	.	C	[Flash] + 2
.	.	D	[Flash] + 3
.	.	E	[Flash] + 4
9	9	F	[Flash] + 5

## 8.1.2. Handset

### Important:

Make sure the address on LCD is correct when entering new data. Otherwise, you may ruin the unit.

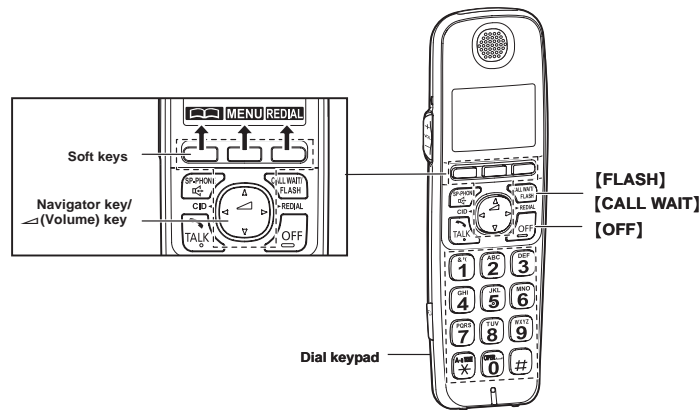

### H/S key operation

- 1). Press **MENU** .
- 2). Select "Initial Setting" using **[▲]** or **[▼]** then press **SELECT** or **[▶]**.
- 3). Enter "7", "2", "6", "2", "7", "6", "6", "4".  
**Note:** 7262 7664 = PANA SONI  
 (see letters printed on dial keys)
- 4). Select "Write EEP" using **[▲]** or **[▼]** then press **SELECT** or **[▶]**.
- 5). Enter "●", "●", "●", "●" (Address). (\*1)
- 6). Enter "\*" , "\*" (New Data). (\*1)
- 7). Press **OK** , a long confirmation beep will be heard.
- 8). Press **[OFF]** to return to standby mode.

### H/S LCD

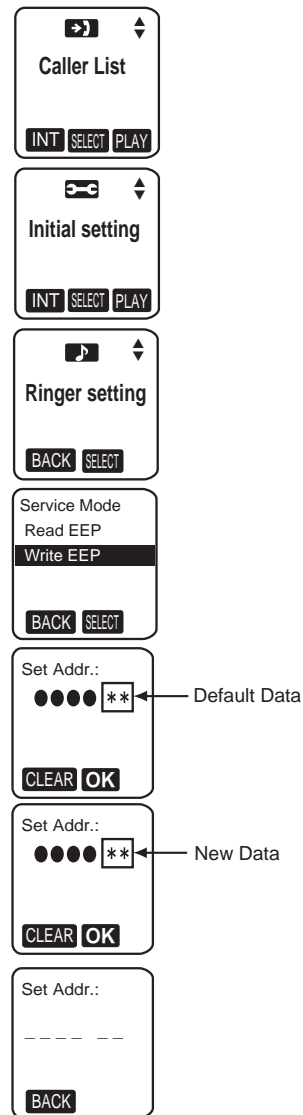

After that, remove and reinsert the batteries. Press the Power button for about 1 second if the power is not turned on.

**Frequently Used Items (Handset)**

ex.)

Items	Address	Default Data	New Data	Possible Adjusted Value MAX (hex)	Possible Adjusted Value MIN (hex)	Remarks
Battery Low	00 12/00 13	00 / 00	-	-	-	(*2)
Frequency	00 07 / 00 08	00 / 01	-	-	-	
ID	00 02 ~ 00 06	Given value	-	-	-	

**Note:**

(\*1) When you enter the address or New Data, please refer to the table below.

Desired Number (hex.)	Input Keys	Desired Number (hex.)	Input Keys
0	0	A	[Flash] + 0
1	1	B	[Flash] + 1
.	.	C	[Flash] + 2
.	.	D	[Flash] + 3
.	.	E	[Flash] + 4
9	9	F	[Flash] + 5

(\*2) Use these items in a READ-ONLY mode to confirm the contents. Careless rewriting may cause serious damage to the handset.

## 9 Service Mode

### 9.1. How to Clear User Setting (Handset Only)

Handset

Press **2**, **5**, **8**, **0** simultaneously until a beep sound is heard. Then single handset is initialized.  
(The contents of user setting are reset to factory default)

\*Usage time is not cleared.

# 10 Troubleshooting Guide

## 10.1. Troubleshooting Flowchart

### FLOW CHART

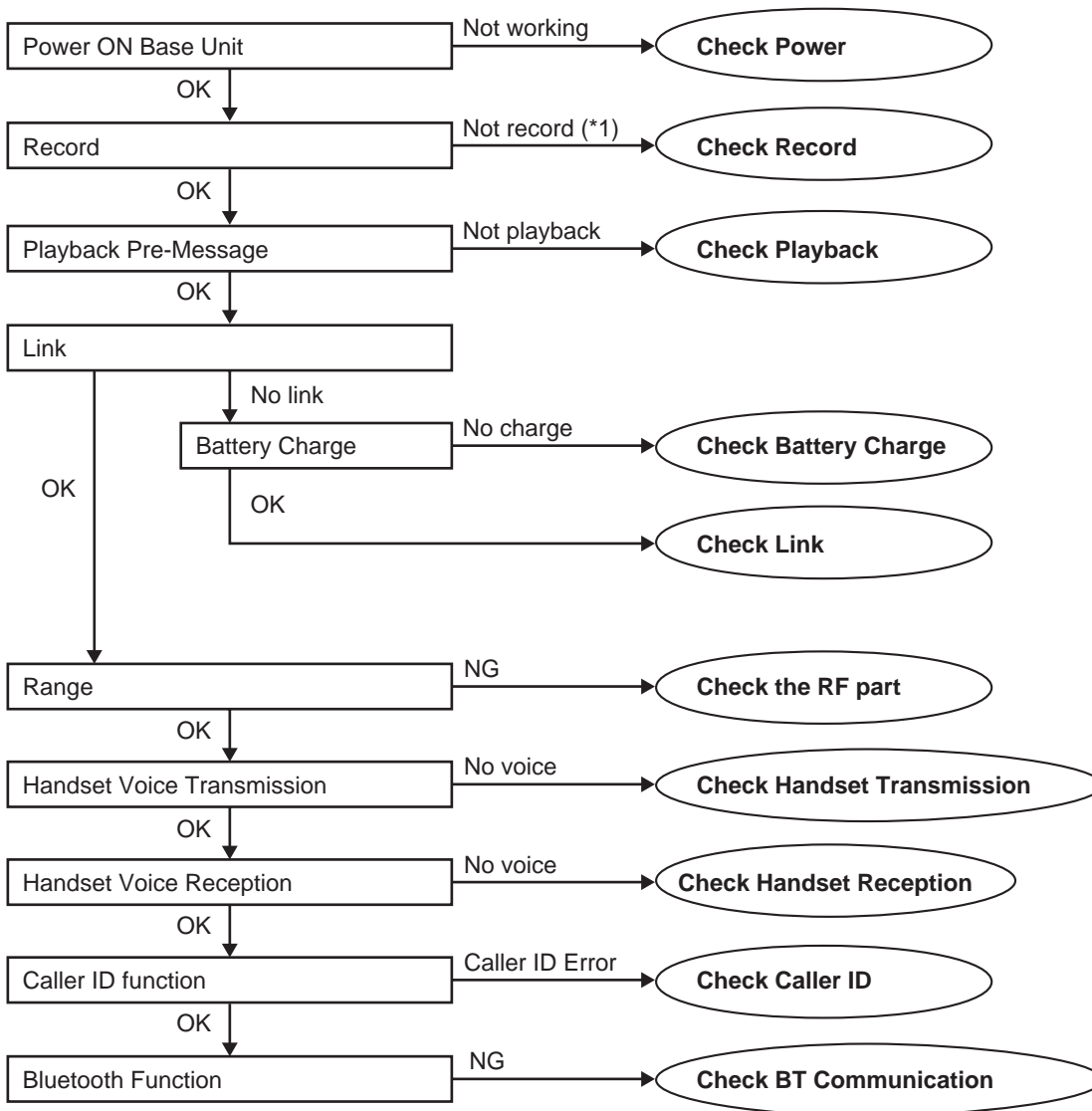

#### Cross Reference:

**Check Power** (P.33)

**Check Record** (P.34)

**Check Playback** (P.37)

**Check Battery Charge** (P.37)

**Check Link** (P.38)

**Check the RF part** (P.40)

**Check Handset Transmission** (P.45)

**Check Handset Reception** (P.45)

**Check Caller ID** (P.45)

**Check BT Communication** (P.46)

#### Note:

(\*1) When a user claims that the unit disconnects a call right after the greeting message and no incoming messages can be recorded, this symptom can not be reappeared with TEL simulator in the service center. In this case, try to change the Auto disconnect activation time and Vox level.

**<How to change the Auto Disconnect activation time and VOX level>** (P.35) item (A) and (B).

## 10.1.1. Check Power

### 10.1.1.1. Base Unit

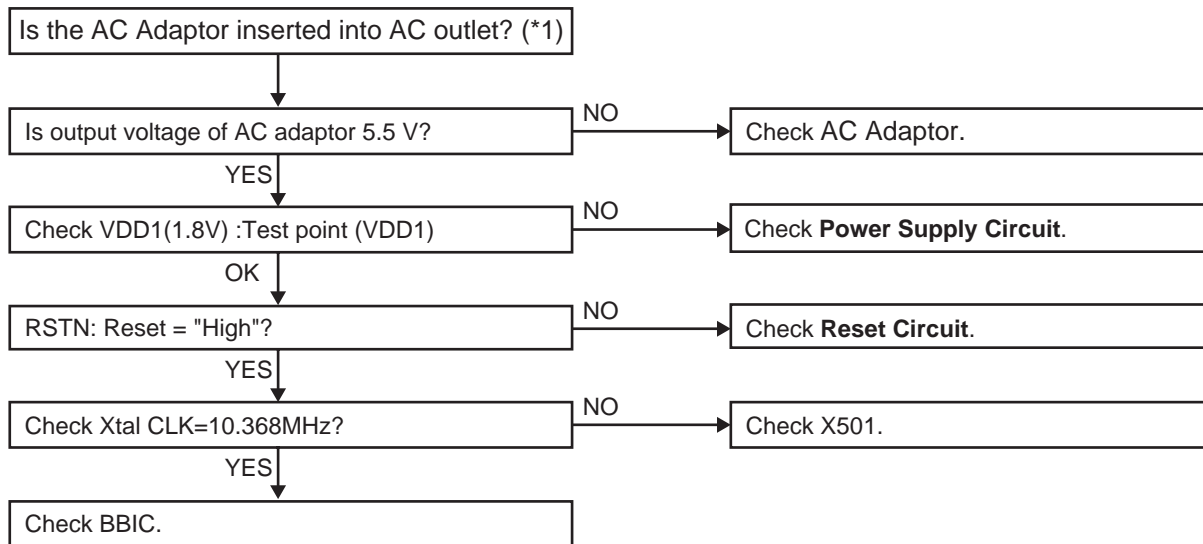

**Cross Reference:**  
Power Supply Circuit/Reset Circuit (P.14)

**Note:**  
BBIC is IC501.  
(\*1) Refer to **Specifications** (P.6) for part number and supply voltage of AC adaptor.  
(\*2) Refer to **Circuit Board (Base Unit\_Main)** (P.81).

### 10.1.1.2. Handset

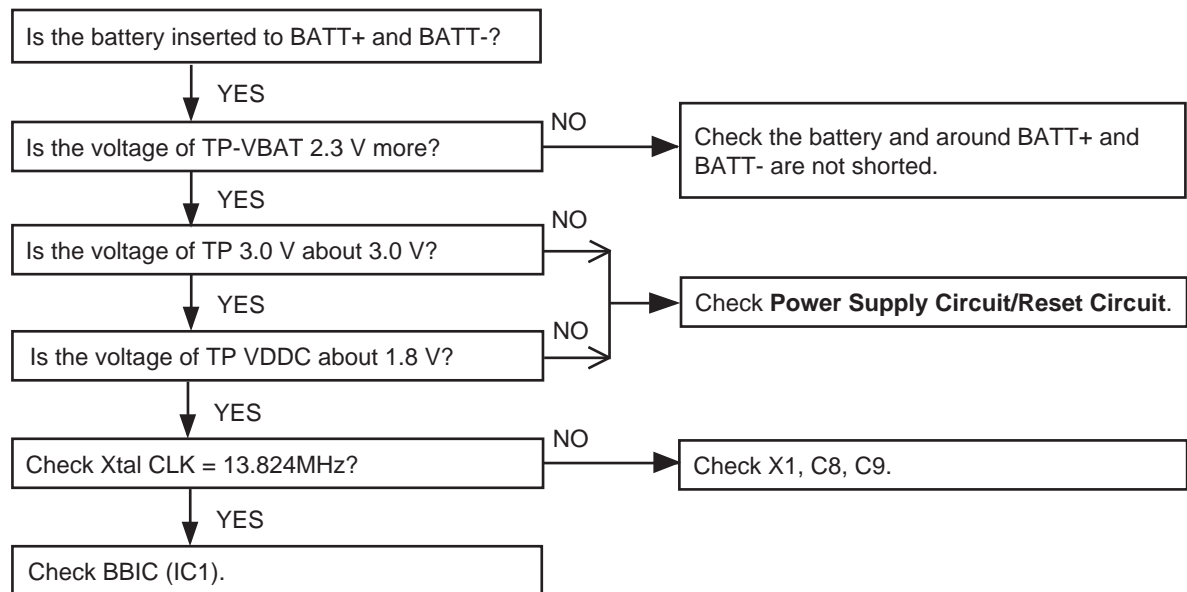

**Cross Reference:**  
Power Supply Circuit/Reset Circuit (P.22)

## 10.1.2. Check Record

### 10.1.2.1. Base Unit

#### Not record Incoming Message

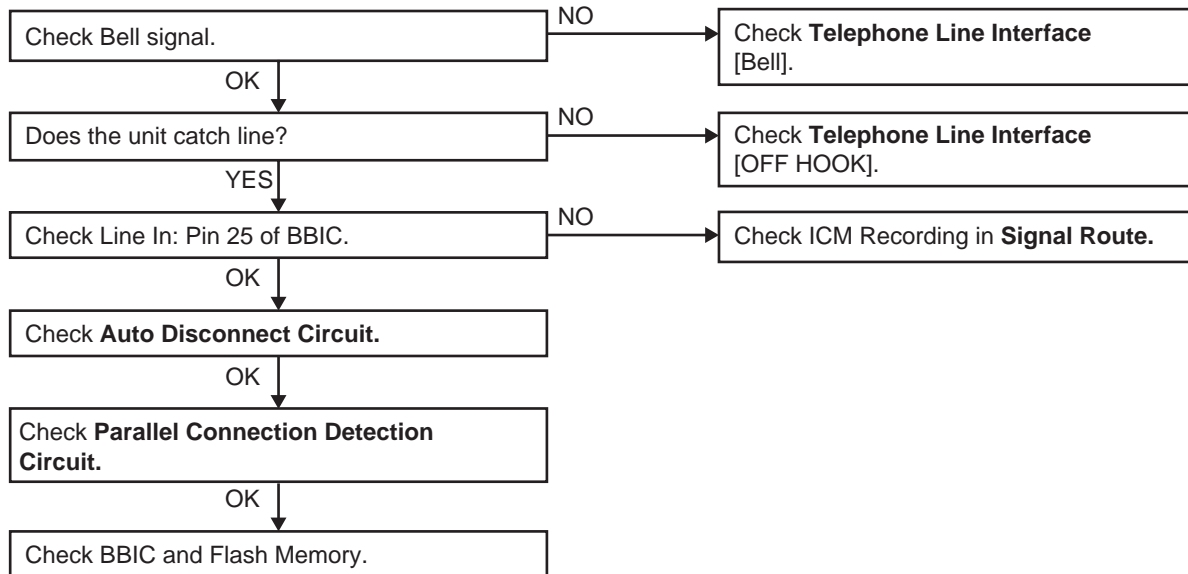

**Cross Reference:**

**Signal Route** (P.24)

**Telephone Line Interface** (P.16)

**Parallel Connection Detect Circuit/Auto Disconnect Circuit** (P.17)

**Note:**

Flash Memory is IC601.

BBIC is IC501.

## <How to change the Auto Disconnect activation time and VOX level>

### A) Auto Disconnect activation time:

Some Telephone Company lines (fiber or cable) ON Hook and OFF Hook voltages are lower than conventional lines, which may cause a malfunction of Auto Disconnect detection. To solve this problem, try changing the Auto Disconnect activation through the procedures below.

- 1) Press "MENU " key at standby Mode and "#" key.

**Note:** The set must power on and be linked.

- 2) Press "9", "0", "0", "0", " \* " .

LCD (H/S)

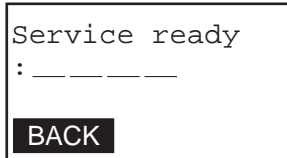

- 3) Press "7", "3", "1".

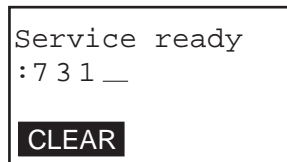

- 4) Then enter the below last digit;

last digit	"0"	Auto disconnect & CPC <sup>(*1)</sup> : enable . . . [default]
	"1"	Auto disconnect : enable <sup>(*1)</sup> CPC : disable
	"2"	Auto disconnect & CPC : disable <sup>(*2)</sup>

**Note:**

(\*1) Both Auto Disconnect and CPC don't detect for the first 2 seconds.

(\*2) If the "Disable" is selected, even if the parallel-connected telephone is OFF HOOK, the line isn't disconnected.

- 5) Back to "standby" mode automatically after step 4).  
You can hear beep sound which is a confirmation tone.

**B) Vox level:**

It makes easier to detect a small voice (caller) by raising the sensitivity of VOX level. Therefore, the recording of TAM is not turned off during a detection.

1) ~ 2) are same as (A).

3) Press "5", "1", "1".

Service ready :5 1 1 _ <b>CLEAR</b>
---

4) Then enter the below last digit;

last digit	"0"	default setting : normal
	"1"	6dB up

5) Back to "standby" mode automatically after step 4).  
You can hear beep sound which is a confirmation tone.

### 10.1.3. Check Playback

#### 10.1.3.1. Base Unit

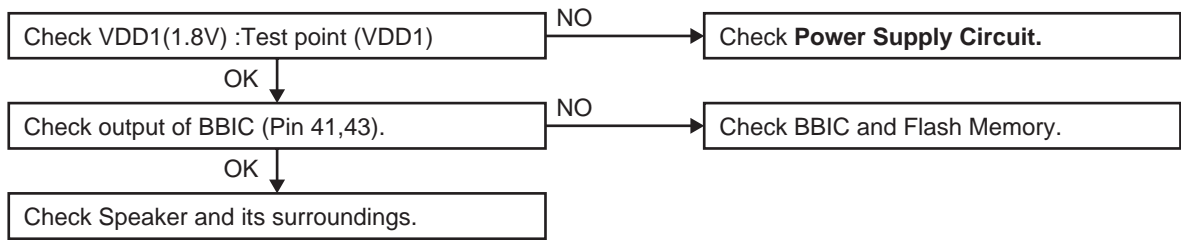

**Cross Reference:**  
**Power Supply Circuit/Reset Circuit (P.14)**

**Note:**  
 Flash Memory is IC601.  
 BBIC is IC1.  
 (\*1) Refer to **Circuit Board (Base Unit\_Main) (P.81)**.

### 10.1.4. Check Battery Charge

#### 10.1.4.1. Base Unit

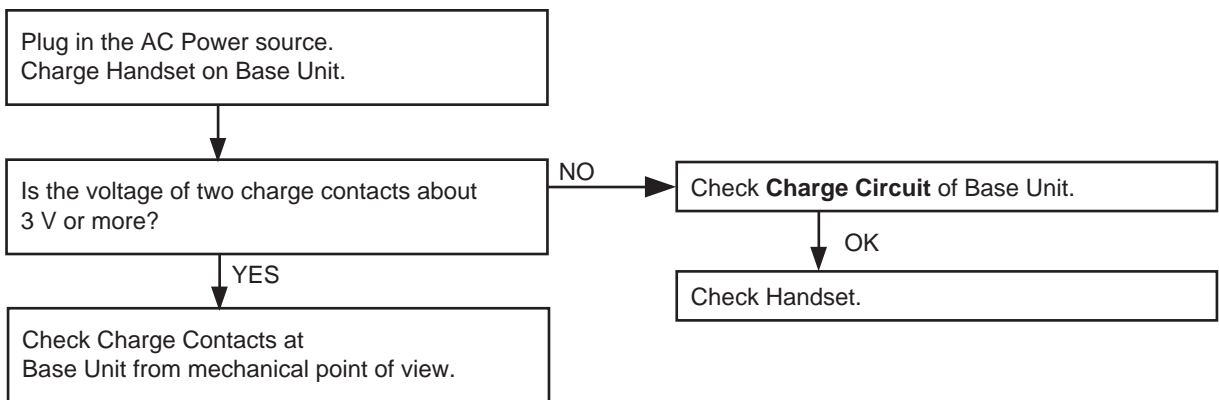

**Cross Reference:**  
**Charge Circuit (P.15)**

#### 10.1.4.2. Handset

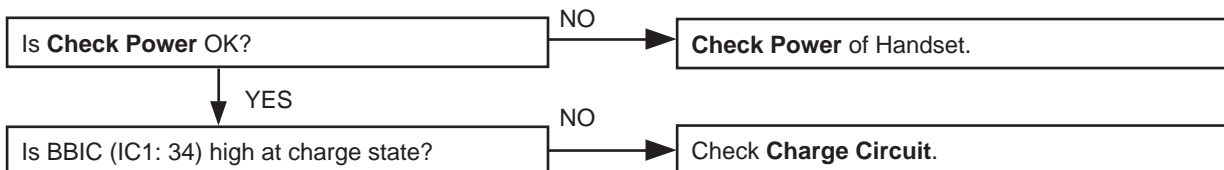

**Cross Reference:**  
**Check Power (P.33)**  
**Charge Circuit (P.23)**

#### 10.1.4.3. Charger Unit

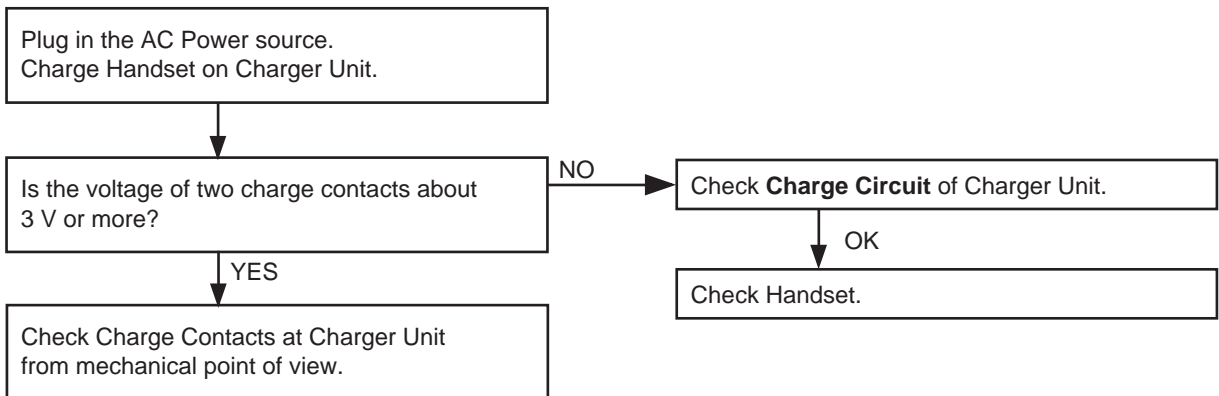

**Cross Reference:**  
**Charge Circuit (P.23)**

## 10.1.5. Check Link

### 10.1.5.1. Base Unit

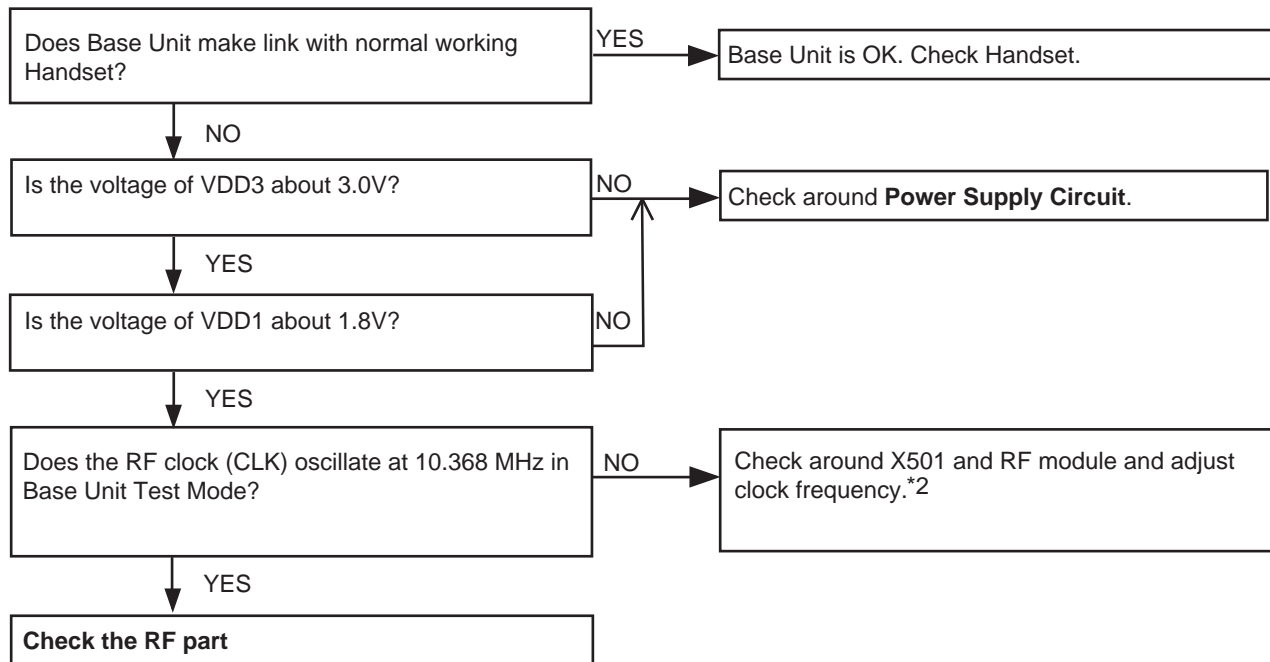

#### Cross Reference:

**Power Supply Circuit/Reset Circuit** (P.14)

**Check the RF part** (P.40)

#### Note:

\*1 How to adjust +3.0V:

Execute the command "VDA"

Refer to **Things to Do after Replacing IC or X'tal** (P.62) for Base Unit.

\*2 How to adjust the frequency of X501:

To see the frequency, execute the command "SFR", then check the TP\_CKM (IC501-57pin).

To adjust frequency, send command "SFR □○○□○○" until the frequency counter becomes 13.824 MHz±55HZ.

### 10.1.5.2. Handset

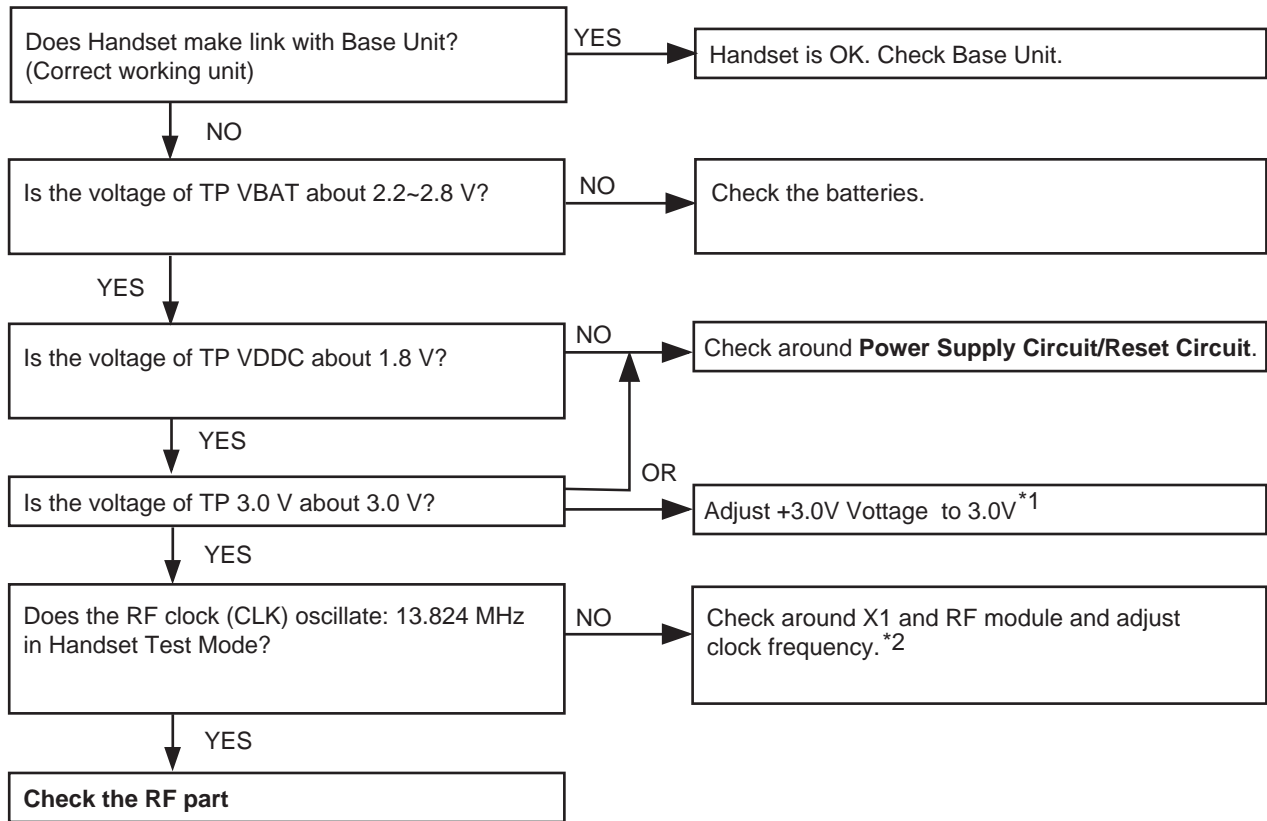

**Cross Reference:**

**Power Supply Circuit/Reset Circuit** (P.22)

**Check the RF part** (P.40)

**Note:**

\*1 How to adjust +3.0V:

Execute the command "VDA"

Refer to **Things to Do after Replacing IC or X'tal** (P.63) for Handset.

\*2 How to adjust the frequency of X1:

To see the frequency, execute the command "SFR", then check the TP\_CKM (IC1-57pin).

To adjust frequency, send command "SFR □○○□○○" until the frequency counter becomes 13.824 MHz±55HZ.

## 10.1.6. Check the RF part

### 10.1.6.1. Finding out the Defective part

1. Prepare Regular HS(\*1) and Regular BU(\*2).
2. a. Re-register regular HS (Normal mode) to base unit (to be checked).  
If this operation fails in some ways, the base unit is defective.
- b. Re-register handset (to be checked) to regular BU (Normal mode).  
If this operation fails in some ways, the handset is defective.

#### After All the Checkings or Repairing

1. Re-register the checked handset to the checked base unit, and Regular HS to Regular BU.

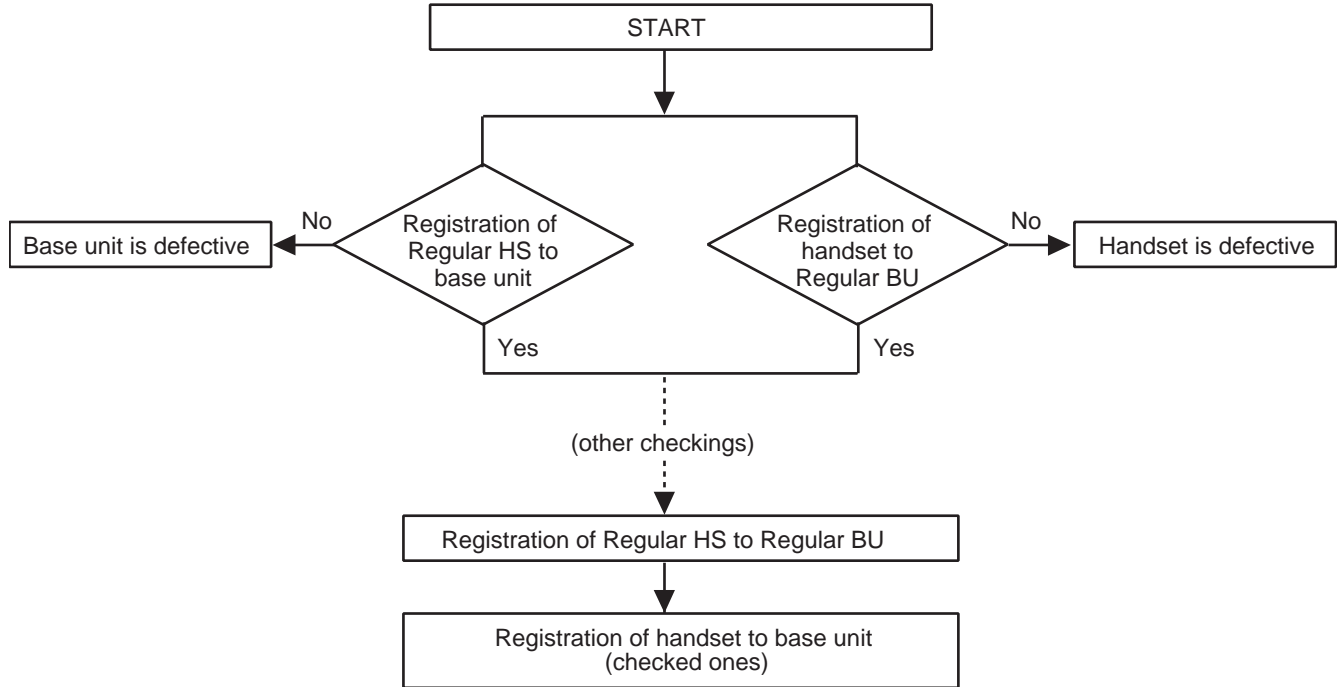

**Note:**

- (\*1) HS: Handset
- (\*2) BU: Base Unit

### 10.1.6.2. RF Check Flowchart

Each item (1 ~ 5) of RF Check Flowchart corresponds to **Check Table for RF part** (P.42).  
Please refer to the each item.

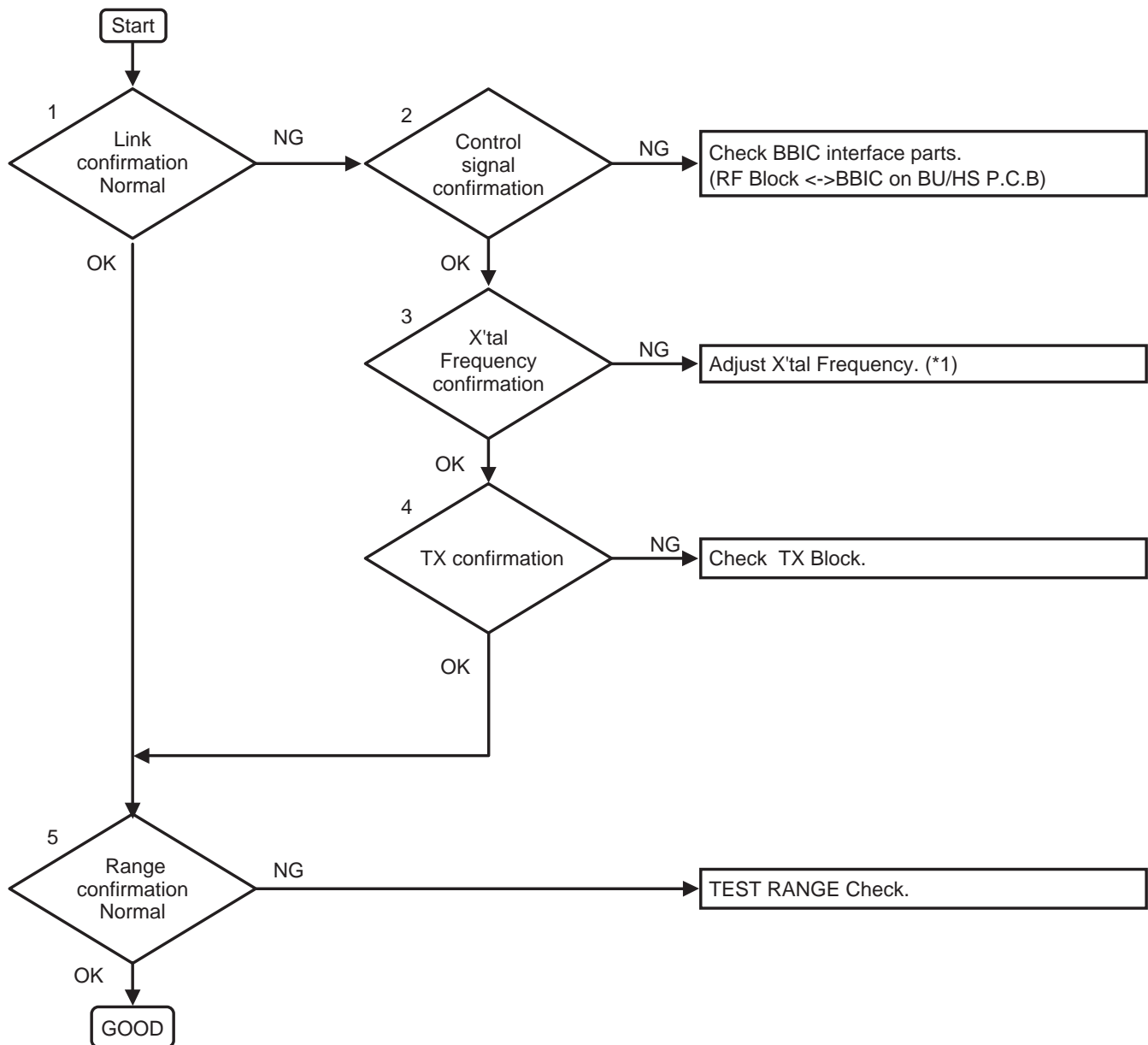

**Note:**

(\*1) Refer to **Check Link** (P.38).

### 10.1.6.3. Check Table for RF part

No.	Item	BU (Base Unit) Check	HS (Handset) Check
1	Link Confirmation Normal HS, BU Mode [Normal Mode]	<ol style="list-style-type: none"> <li>1. Register Regular HS to BU (to be checked).</li> <li>2. Press [Talk] key of the Regular HS to establish link.</li> </ol>	<ol style="list-style-type: none"> <li>1. Register HS (to be checked) to Regular BU.</li> <li>2. Press [Talk] key of the HS to establish link.</li> </ol>
2	X'tal Frequency confirmation HS, BU Mode: [Adjustment]	Check X'tal Frequency. (10.368 MHz $\pm$ 100Hz)	Check X'tal Frequency. (13.824 MHz $\pm$ 100 Hz)
3	TX confirmation HS Mode: HS_Burst Mode] (*1) BS Mode: BS_Burst Mode] (*1)	<ol style="list-style-type: none"> <li>1. Remove wire antenna 2 and connect spectrum analyzer to TP. (*2)</li> <li>2. Confirm TX power whether spec. is satisfied. Power <math>\geq</math>13.5dBm</li> </ol>	<ol style="list-style-type: none"> <li>1. Connect spectrum analyzer to TP. (*3)</li> <li>2. Confirm TX power whether satisfied spec. Power <math>\geq</math>16.0dBm</li> </ol>
4	Range Confirmation Normal HS, BU Mode: [Normal Mode]	<ol style="list-style-type: none"> <li>1. Register Regular HS to BU (to be checked).</li> <li>2. Press [Talk] key of the Regular HS to establish link.</li> <li>3. Compare the range of the BU (being checked) with that of the Regular BU.</li> </ol>	<ol style="list-style-type: none"> <li>1. Register HS (to be checked) to Regular BU.</li> <li>2. Press [Talk] key of the HS to establish link.</li> <li>3. Compare the range of the HS (being checked) with that of the Regular HS.</li> </ol>

**Note:**

(\*1) Refer to **Commands** (P.58)

(\*2) **Adjustment Standard (Base Unit)** (P.59)

(\*3) **Adjustment Standard (Handset)** (P.61)

### 10.1.6.4. TEST RANGE Check

Circuit block which range is defective can be found by the following check.

Item	BU (Base Unit) Check	HS (Handset) Check
Range Confirmation TX TEST (TX Power check)  HS, BU setting Checked unit: Low TX power (*1) Regular unit: High TX power (*1)	<ol style="list-style-type: none"> <li>1. Register Regular HS to BU (to be checked).</li> <li>2. Set TX Power of the BU and the Regular HS according to CHART1.</li> <li>3. At distance of about 20m between HS and BU, Link OK = TX Power of the BU is OK. No Link = TX Power of the BU is NG.</li> </ol>	<ol style="list-style-type: none"> <li>1. Register HS (to be checked) to Regular BU.</li> <li>2. Set TX Power of the HS and the Regular BU according to CHART1.</li> <li>3. At distance of about 20m between HS and BU, Link OK = TX Power of the HS is OK. No Link = TX Power of the HS is NG.</li> </ol>
Range Confirmation RX TEST (RX sensitivity check)  HS, BU setting Checked unit: High TX power (*1) Regular unit: Low TX power (*1)	<ol style="list-style-type: none"> <li>1. Register Regular HS to BU (to be checked).</li> <li>2. Set TX Power of the BU and the Regular HS according to CHART1.</li> <li>3. At distance of about 20m between HS and BU, Link OK= RX Sensitivity of the BU is OK. No Link = RX Sensitivity of the BU is NG.</li> </ol>	<ol style="list-style-type: none"> <li>1. Register HS (to be checked) to Regular BU.</li> <li>2. Set TX Power of the Checking HS and the Regular BU according to CHART1.</li> <li>3. At distance of about 20m between HS and BU, Link OK= RX Sensitivity of the HS is OK. No Link = RX Sensitivity of the HS is NG</li> </ol>

**CHART1: Setting of TX Power and RX Sensitivity in Range Confirmation TX TEST, RX TEST**

	BU (to be checked)	Regular_HS
	TX Power	TX Power
BU (Base Unit) TX Power Check	Low	High
BU (Base Unit) RX Sensitivity Check	High	<b>Low</b>

	HS (to be checked)	Regular_BU
	TX Power	TX Power
HS (Handset) TX Power Check	Low	High
HS (Handset) RX Sensitivity Check	High	<b>Low</b>

**Note:**

(\*1) Refer to **Commands** (P.58).

### 10.1.7. Registering a Handset to the Base Unit

The supplied handset and base unit are pre-registered. If for some reason the handset is not registered to the base unit, re-register the handset.

**1 Handset:**

**[MENU]** → **# 1 3 0**

**2 Base unit:**

Press and hold **[LOCATOR]** for about 5 seconds until the registration tone sounds.

- If all registered handsets start ringing, press **[LOCATOR]** again to stop, then repeat this step.
- The next step must be completed within 90 seconds.

**3 Handset:**

Press **[OK]**, then wait until a long beep sounds.

**Note:**

- While registering, “**Base in registering**” is displayed on all registered handsets.
- When you purchase an additional handset, refer to the additional handset’s installation manual for registration.

### 10.1.8. Deregistering a Handset

A handset can cancel its own registration to the base unit, or other handsets registered to the same base unit. This allows the handset to end its wireless connection with the system.

**1 [MENU]** → **# 1 3 1**

- All handsets registered to the base unit are displayed.

**2 [↓]**: Select the handset you want to cancel. → **[SELECT]**

**3 [↑]**: “**Yes**” → **[SELECT]**

**4 [OFF]**

### 10.1.9. Check Handset Transmission

Check MIC of handset.



Check handset Tx in **Signal Route**.

**Cross Reference:**  
**Signal Route** (P.24)

### 10.1.10. Check Handset Reception

Check speaker of handset.



Check handset Rx in **Signal Route**.

**Cross Reference:**  
**Signal Route** (P.24)

**Note:**  
When checking the RF part, Refer to **Check the RF part** (P.40).

### 10.1.11. Check Caller ID

#### BASE UNIT

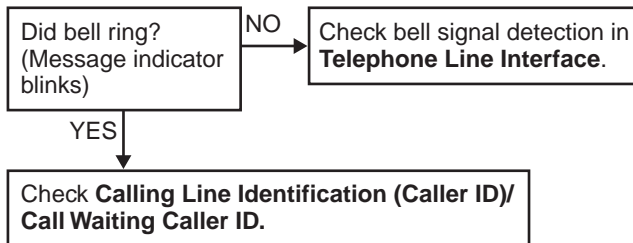

**Cross Reference:**  
**Telephone Line Interface** (P.16)  
**Calling Line Identification (Caller ID)/Call Waiting Caller ID** (P.18)

**Note:**

- Make sure the format of the Caller ID service of the Telephone company that the customer subscribes to.
- It is also recommended to confirm that the customer is really a subscriber of the service.

### 10.1.12. Check BT Communication

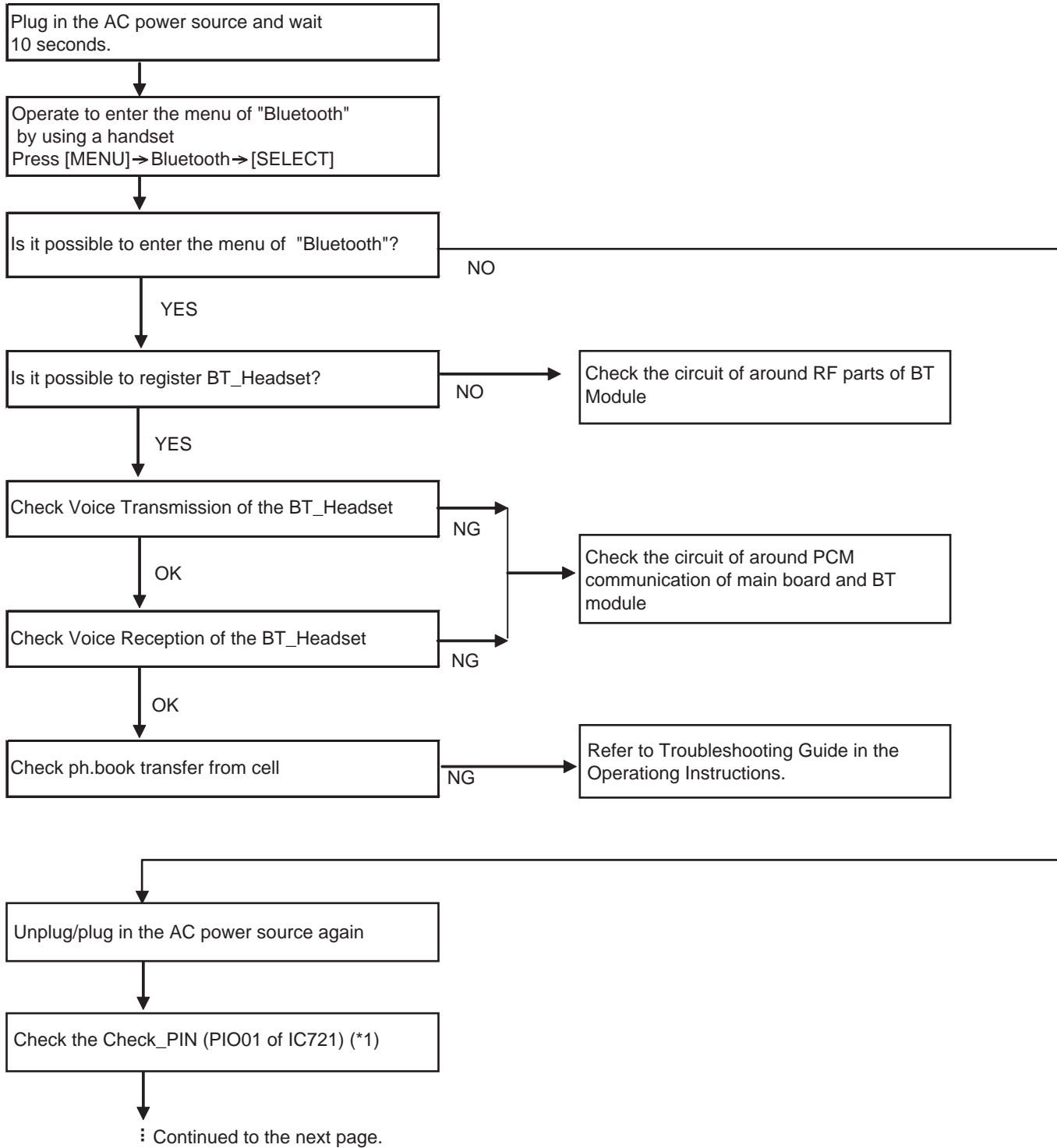

**Cross Reference:**  
**Bottom View (P.82)**

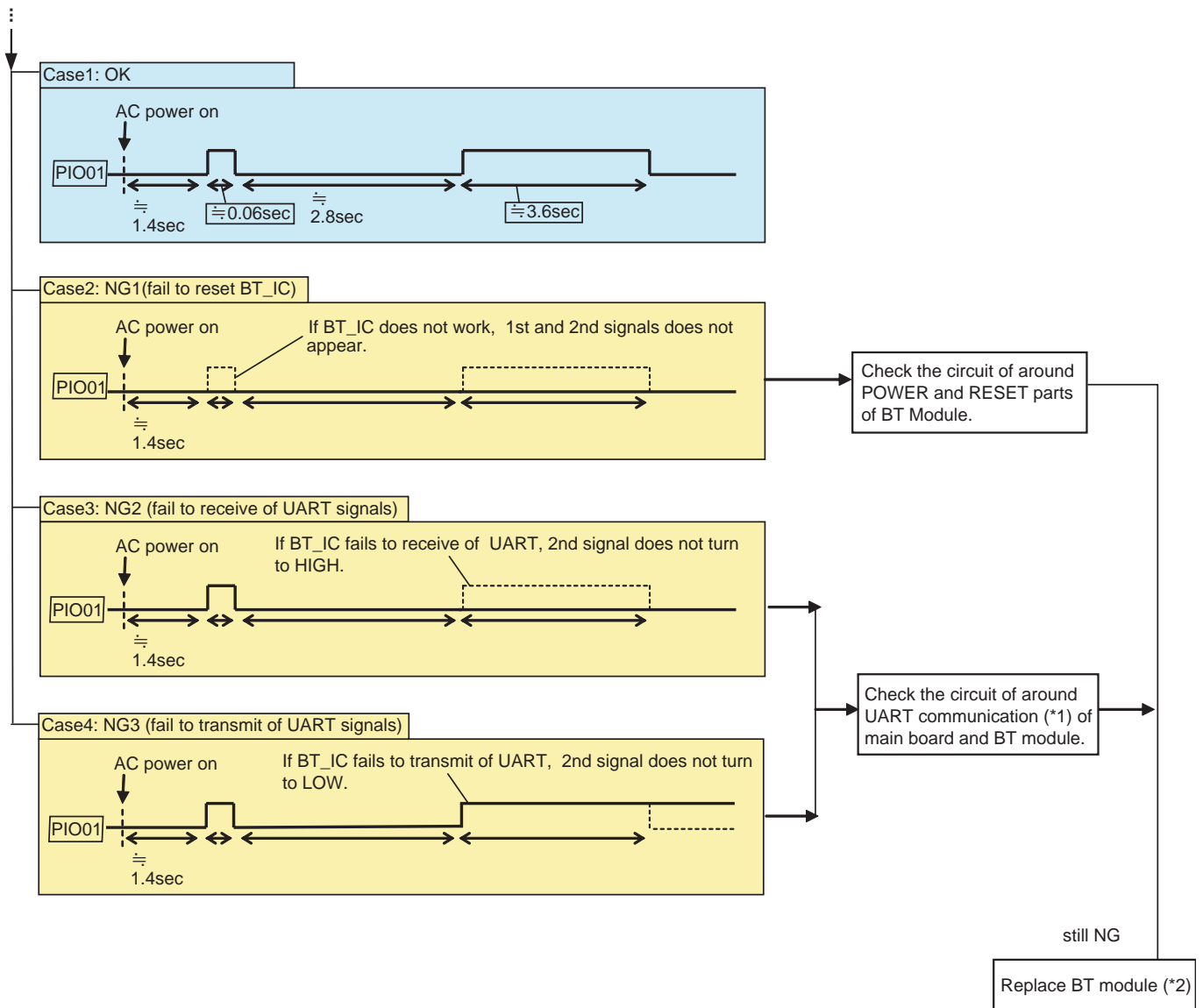

**Cross Reference:**  
**Schematic Diagram (Base Unit\_RF) (P.74)**

**Note:**  
 (\*2) After replacing, need to adjust the frequency of BT.  
 Refer to **Things to Do after Replacing IC or X'tal (P.62)**

# 11 Disassembly and Assembly Instructions

## 11.1. Disassembly Instructions

### 11.1.1. Base Unit

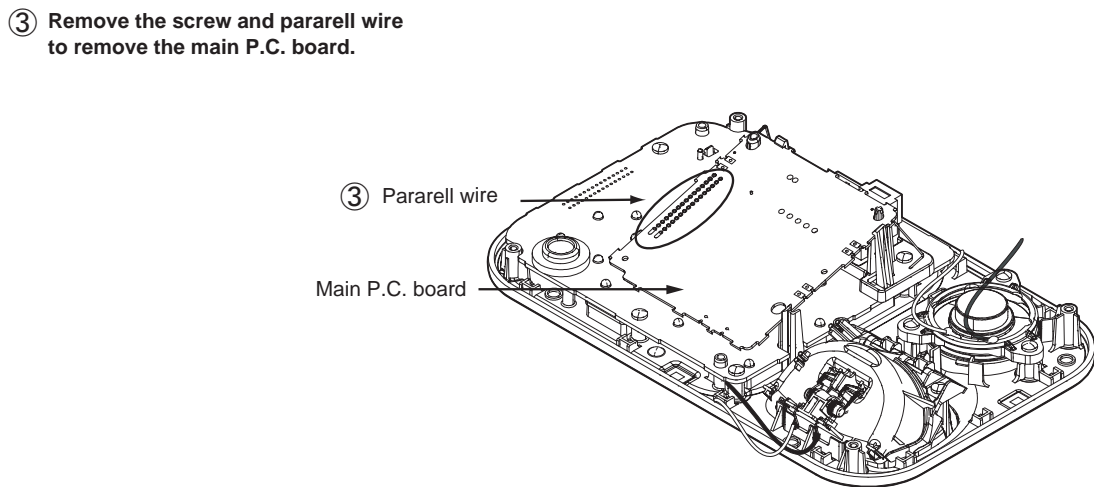
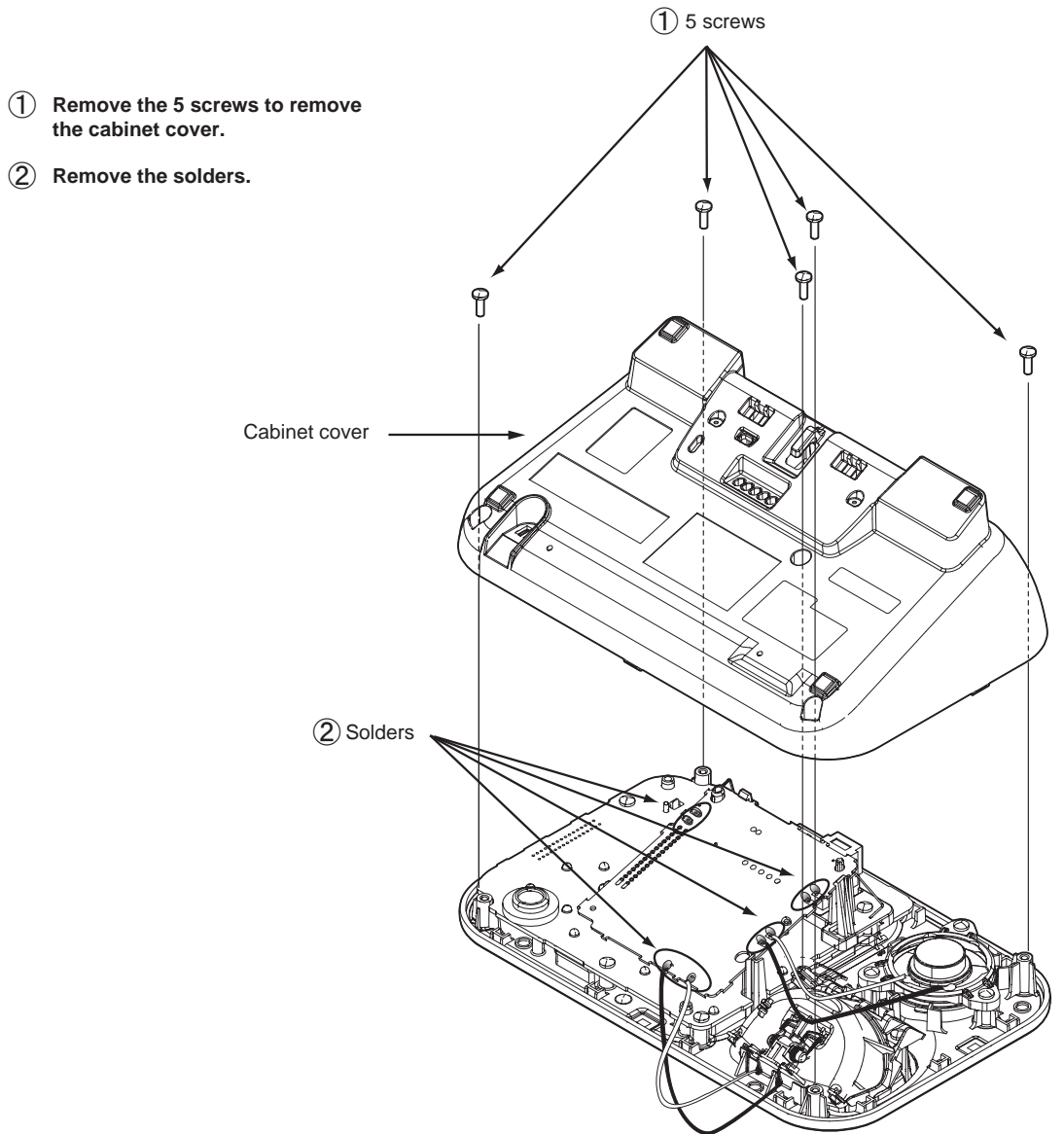

- ④ Remove the 2 screws to remove the Jack holder.

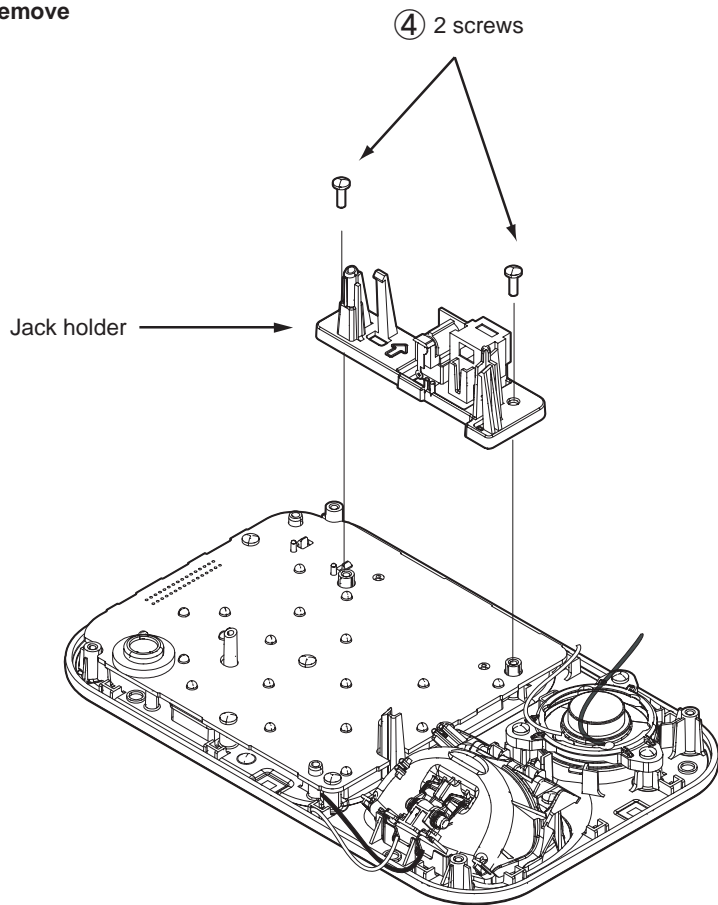

- ⑤ Remove the 4 screws to remove the operational P.C.B board.

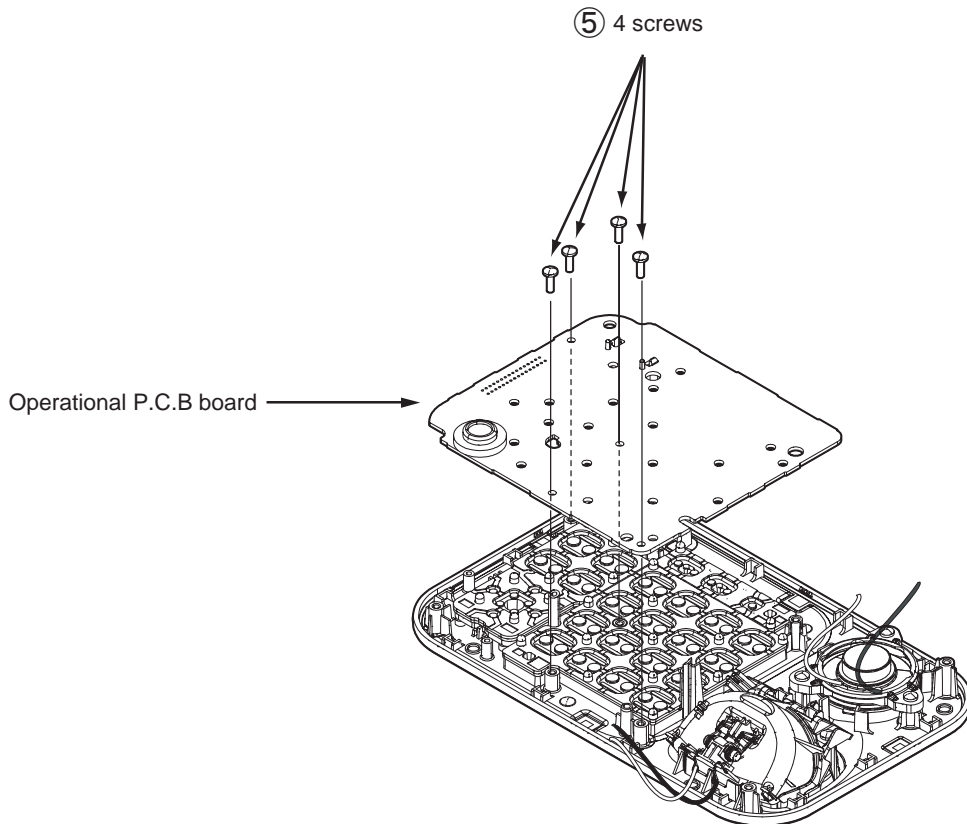

## 11.1.2. Handset

- ① Remove the 2 screws.

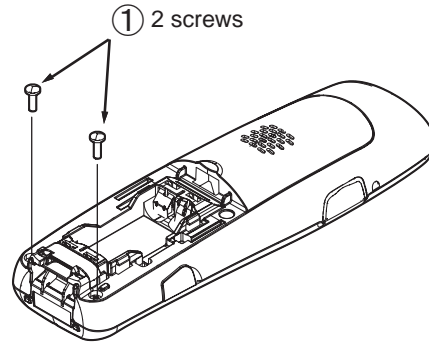

- ② Insert a plastic card. (Ex. Used SIM card etc.) between the cabinet body and the cabinet cover, then pull it along the gap to open the cabinet.

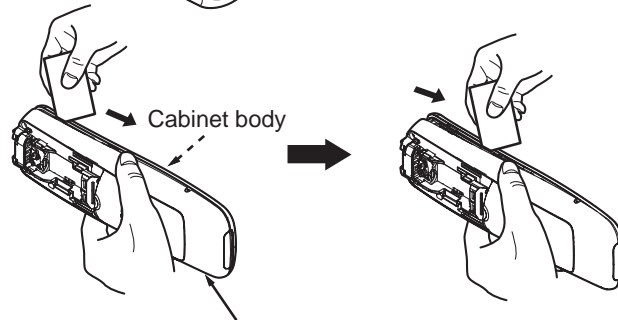

- ③ Likewise, open the other side of the cabinet.

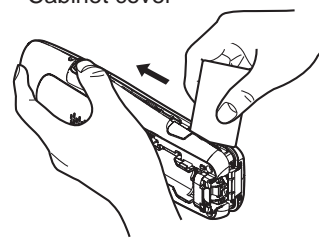

- ④ Remove the cabinet cover by pushing it upward.

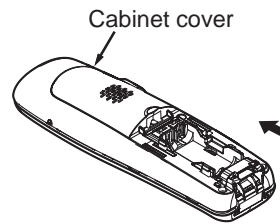

- ⑤ Remove the solders and tape.

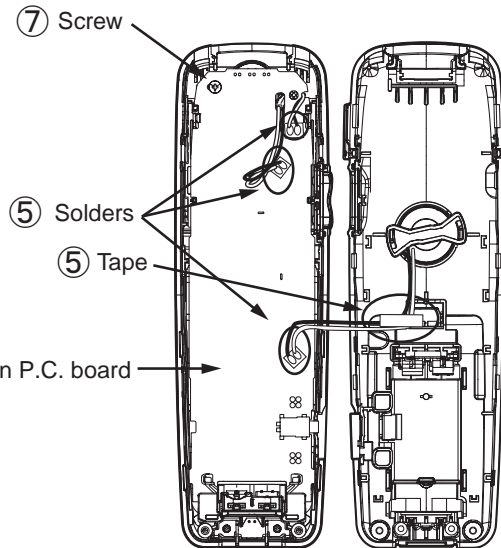

- ⑥ Remove the 2 screws to remove the 2 charge terminals.

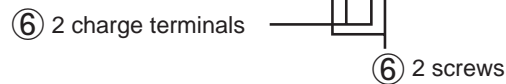

- ⑦ Remove the screw to remove the main P. C. board.

### 11.1.3. Charger Unit

① Remove the screw to remove the cabinet cover.

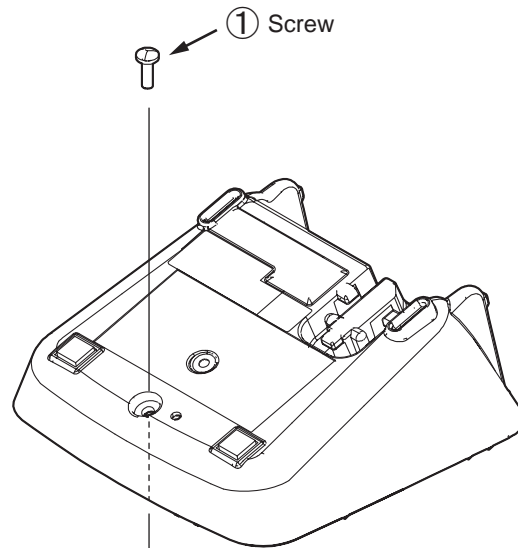

② Remove the solders to remove the 2 charge terminals.

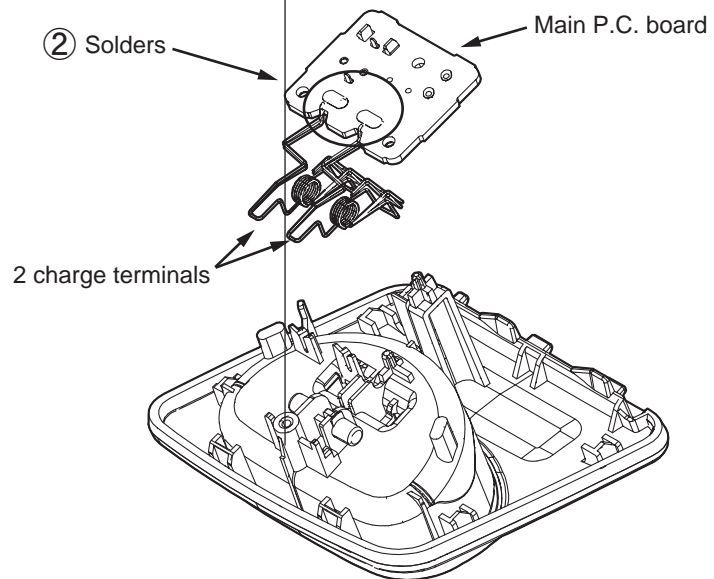

## 11.2. How to Replace the Base unit LCD

- ① Fit the heatseal of a new LCD.

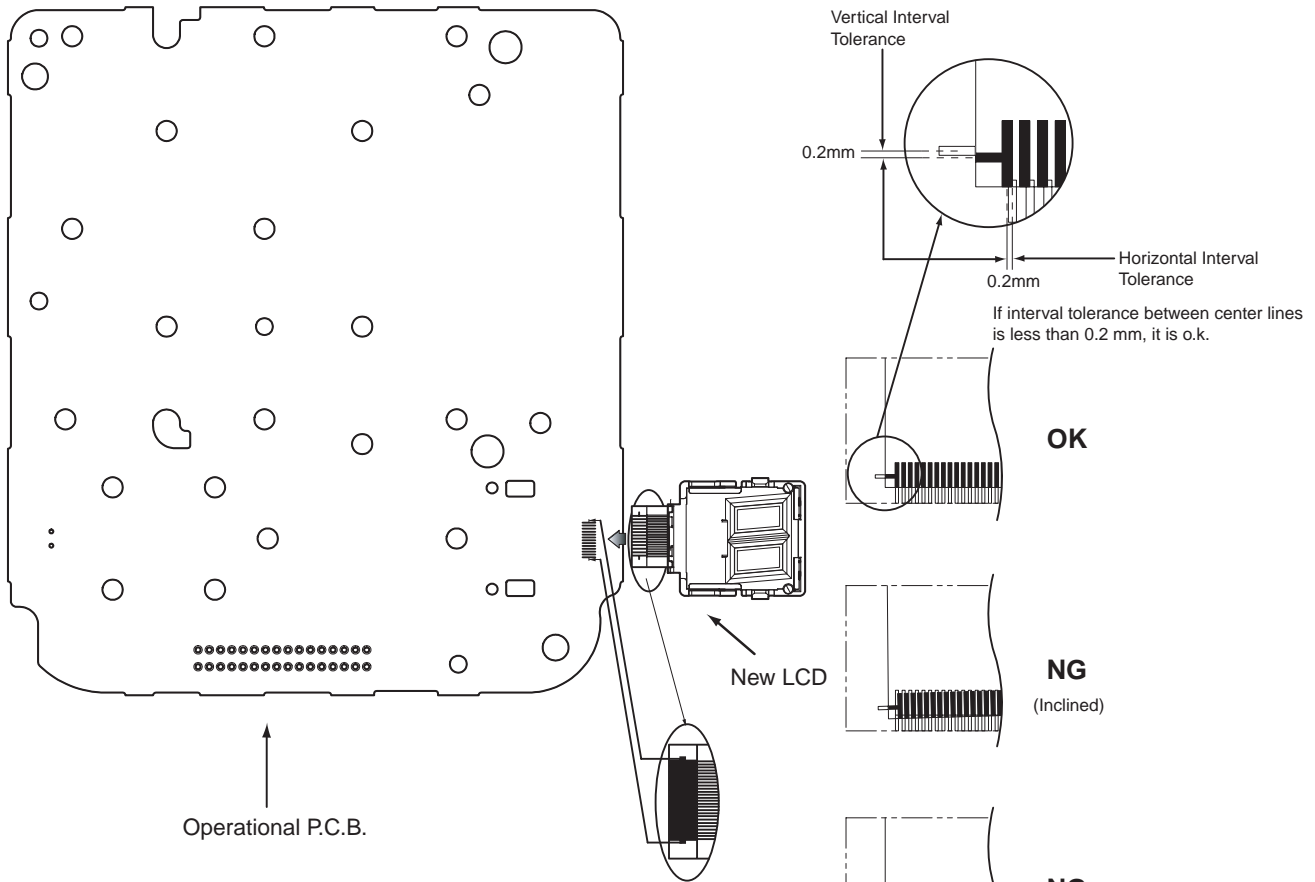

- ② Heatweld with the tip of the soldering iron about 5 to 8 seconds (in case of 60W soldering iron).

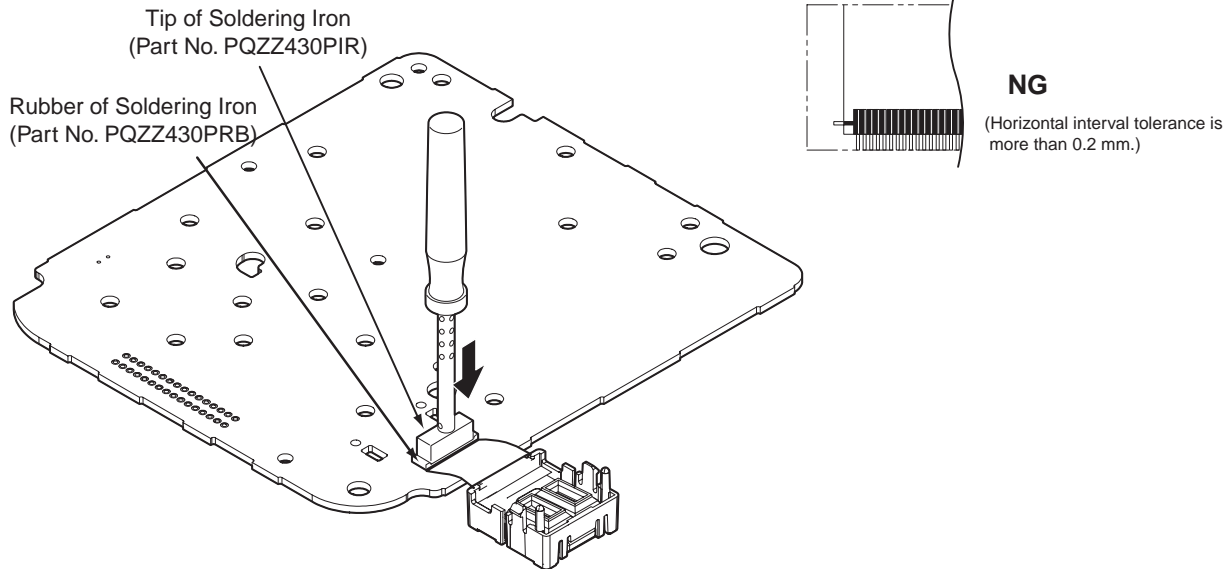

③ Attach the LCD and fix by hook A (two points).

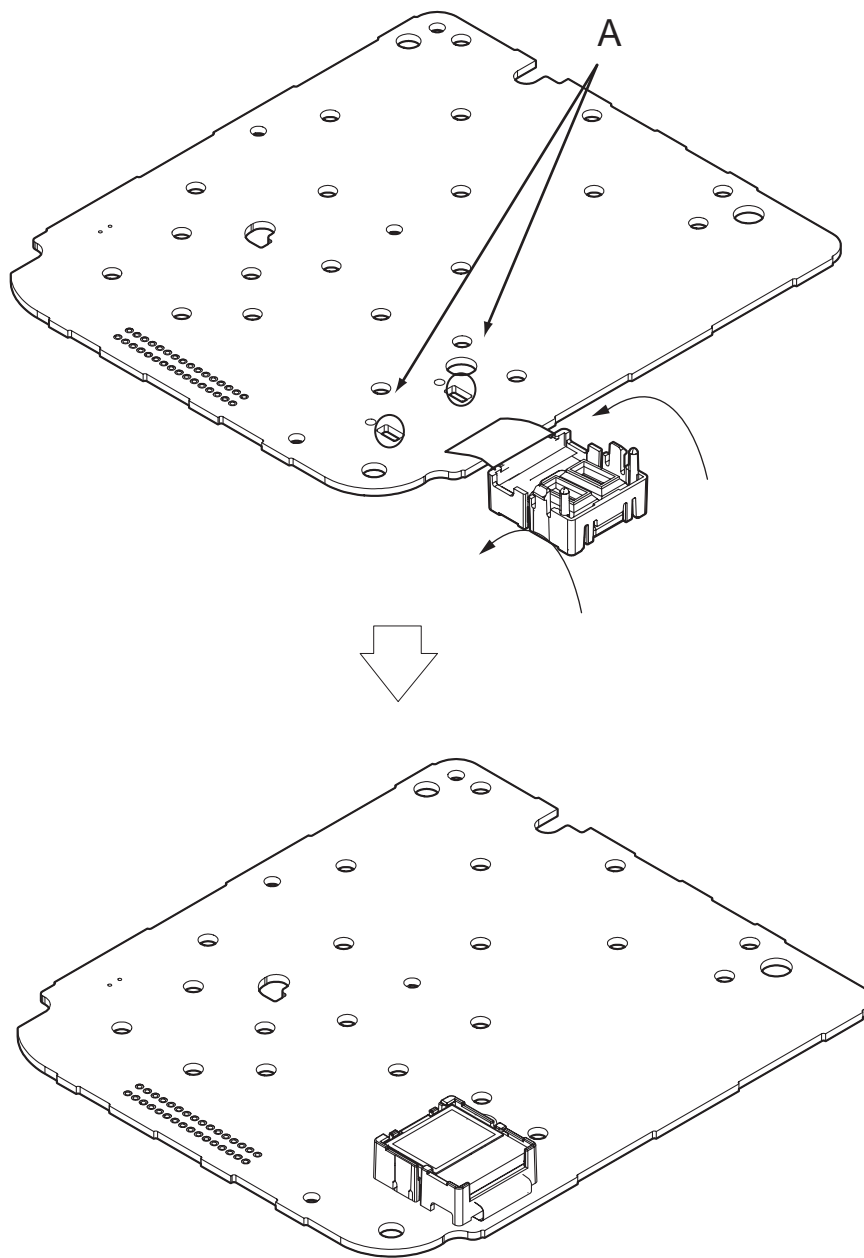

# 11.3. How to Replace the Handset LCD

**Note:**

The illustrations are simplified in this page.  
They may differ from the actual product.

①

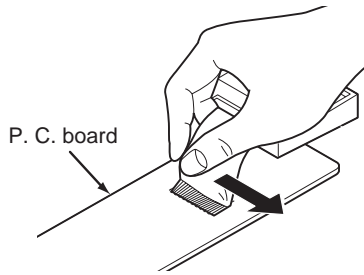

Peel off the FFC (Flexible Flat Cable) from the LCD, in the direction of the arrow. Take care to ensure that the foil on the P.C. board is not damaged.

②

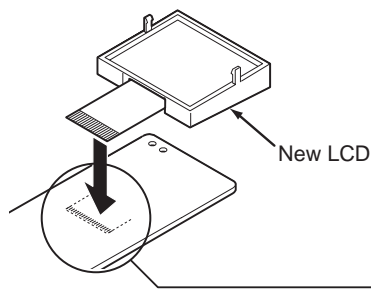

Fit the heatseal of a new LCD.

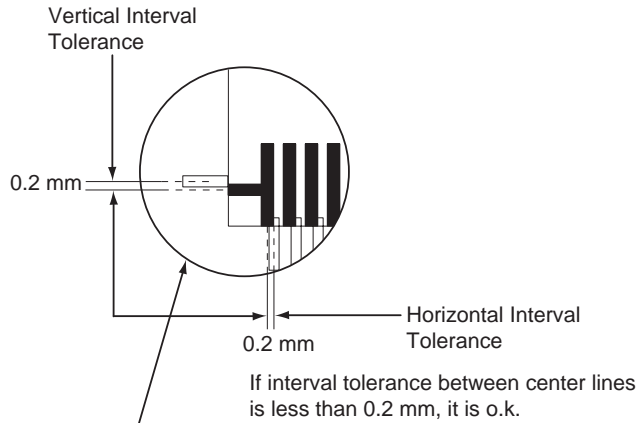

③

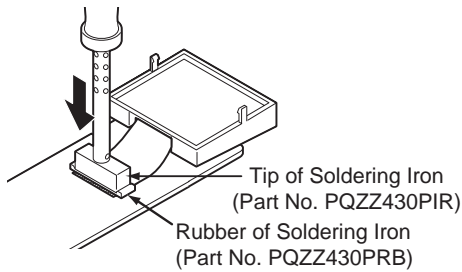

Heatweld with the tip of the soldering iron about 5 to 8 seconds (in case of 60W soldering iron).

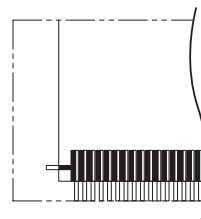
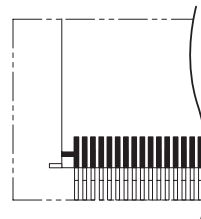
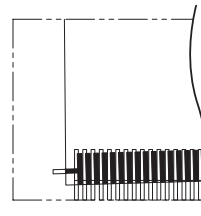
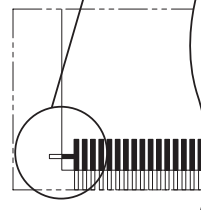

# 12 Measurements and Adjustments

This chapter explains the measuring equipment, the JIG connection, and the PC setting method necessary for the measurement in **Troubleshooting Guide** (P.32)

## 12.1. Equipment Required

- Digital multi-meter (DMM): it must be able to measure voltage and current.
- Oscilloscope.
- Frequency counter: It must be precise enough to measure intervals of 1 Hz (precision;  $\pm 4$  ppm)  
Hewlett Packard, 53131A is recommended.
- DECT tester: Rohde & Schwarz, CMD 60 is recommended.  
This equipment may be useful in order to precisely adjust like a mass production.

## 12.2. The Setting Method of JIG

<Preparation>

- Serial JIG cable: PQZZ1CD300E\*
- PC which runs in DOS mode
- **Batch file CD-ROM** for setting: PNZZTG7741M

**Note:**

\*: If you have the JIG Cable for TCD500 series (PQZZ1CD505E), change the following values of resistance. Then you can use it as a JIG Cable for both TCD300 and TCD500 series. (It is an upper compatible JIG Cable.)

Resistor	Old value (k $\Omega$ )	New value (k $\Omega$ )
R2	22	3.3
R3	22	3.3
R4	22	4.7
R7	4.7	10

### 12.2.1. Connections (Base Unit)

- ① Connect the AC adaptor.
- ② Connect the JIG Cable GND (black).
- ③ Connect the JIG Cable RX (red) and TX (yellow).

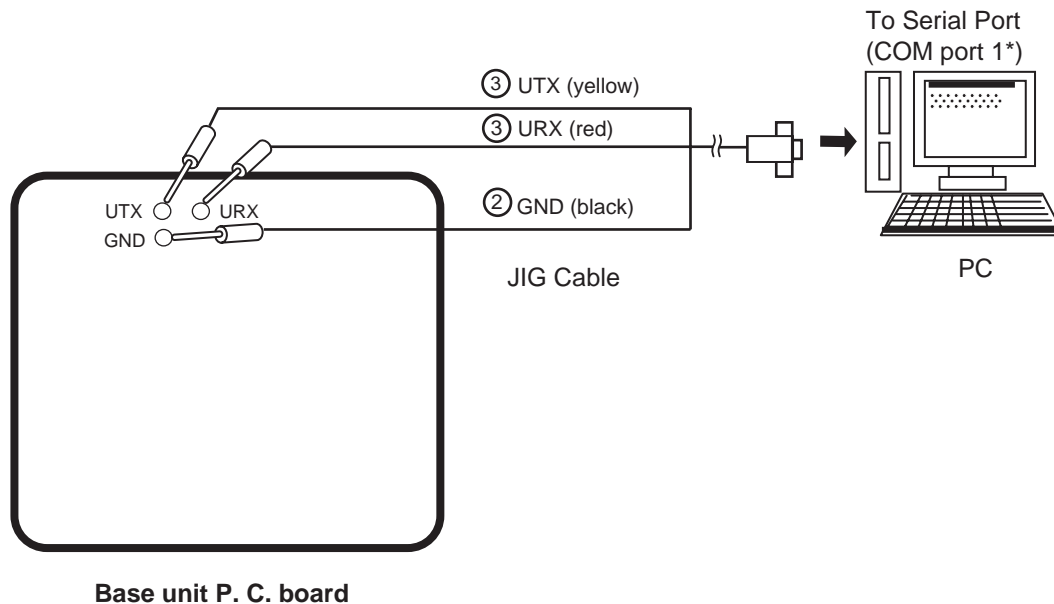

**Note:**

\*: COM port names may vary depending on what your PC calls it.

## 12.2.2. Connections (Handset)

- ① Connect the DC Power or Battery to BATT+ and BATT-.
- ② Connect the JIG cable GND (black) to GND.
- ③ Connect the JIG cable UTX (yellow) to UTX and URX (red) to URX.

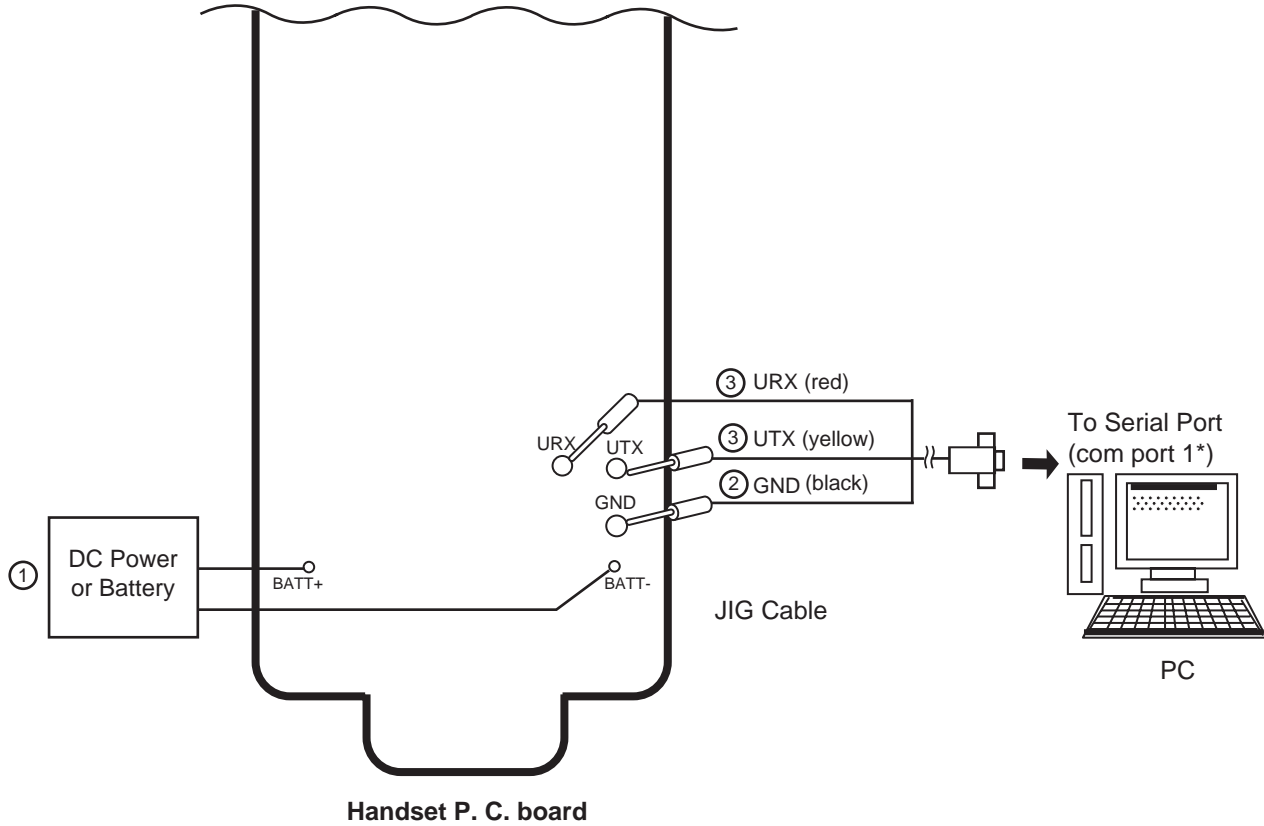

**Note:**

\*: COM port names may vary depending on what your PC calls it.

### 12.2.3. How to install Batch file into P.C.

1. Insert the Batch file CD-ROM into CD-ROM drive and copy PNZZTG\*\*\*\* folder to your PC (example: D drive).

2. Open an MS-DOS mode window.

3. At the DOS prompt, type "D:" (for example) to select the drive, then press the **Enter** key.

4. Type "CD ¥PNZZTG\*\*\*\*", then press the **Enter** key.

5. Type "SET\_COM=X", then press the **Enter** key  
(X: COM port number used for the serial connection on your PC).

6. Type "READID", then press the **Enter** key.  
 • If any error messages appear, change the port number or check the cable connection.  
 • If any value appear, go to next step.

7. Type "DOSKEY", then press the **Enter** key.

#### <Example for Windows>

On your computer, click **[Start]**, select **Programs** (**All Programs** for Windows XP/Windows Server 2003), then click  
**MS-DOS Prompt.** (for Windows 95/Windows 98)  
 Or  
**Accessories-MS-DOS Prompt.** (for Windows Me)  
 Or  
**Command Prompt.** (for Windows NT 4.0)  
 Or  
**Accessories-Command Prompt.**  
 (for Windows 2000/Windows XP/Windows Server 2003)

#### <Example>

```
C: ¥Documents and Settings>D:
D: ¥>CD ¥PNZZTG****
D: ¥PNZZTG**** >SET_COM=X
D: ¥PNZZTG****>READID
00 52 4F A8 A8
D: ¥PNZZTG****>DOSKEY
D: ¥PNZZTG****>_
```

#### <Example: error happens>

```
C: ¥Documents and Settings>D:
D: ¥>CD ¥PNZZTG****
D: ¥PNZZTG**** >SET_COM=X
D: ¥PNZZTG****>READID
CreateFile error
ERROR 10: Can't open serial port
D: ¥PNZZTG ****>_
```

#### Note:

- "\*\*\*\*" varies depending on the country or models.

## 12.2.4. Commands

See the table below for frequently used commands.

Command name		Function	Example
XBT 0		Base unit only. For excluding failure of command response. Please send this command at first before other command is executed. *However, if you want to execute "#X" command then DO NOT USE this command.	Type "sendchar XBT 0".
rdeeprom		Read the data of EEPROM	Type "rdeeprom 00 00 FF", and the data from address "00 00" to "FF" is read out.
readid		Read ID (RFPI)	Type "readid", and the registered ID is read out.
writeid		Write ID (RFPI)	Type "writeid 00 18 E0 0E 98", and the ID "0018 E0 0E 98" is written.
hookoff		Off-hook mode on Base	Type "hookoff".
hookon		On-hook mode on Base	Type "hookon".
getchk (Base unit)		Read checksum	Type "getchk".
How to use of "getchk" in Handset	1.rdeeprom	Read EEPROM	Type "RdEeprom 03 7D 04", and the data from address "03 7D" to "03 80" is read out *This command gets 4 byte "WW", "XX", "YY", "ZZ". *Please NEVER forget these 4 byte data!
	2.sendchar epw	Write EEPROM	Type "sendchar epw 03 7D 04 FF FF FF FF"
	3.sendchar RST	Reset baseset	Type "sendchar RST"
	4.getchk	Read checksum	Type "getchk".
	5.sendchar epw	Write EEPROM	Type "sendchar epw 03 7D 04 WW XX YY ZZ" **"WW", "XX", "YY", "ZZ" is 4 byte data that already read from same address.
wreeprom		Write the data of EEPROM	Type "wreeprom 01 23 45". "01 23" is address and "45" is data to be written.
hs_burst		Handset outputs RF power in burst test mode	Type"hs_burst"
bs_burst		Base unit outputs RF power in burst test mode on antenna 2	Type"bs_burst"
tx_high		Keep TX power high	Type"tx_high"
tx_low		Keep TX power low	Type"tx_low"
How to using "#X" command for base unit			
XBT		Enter this command before using following command "#X", "bs_burst", tx_high" tx_low" for Base Unit.	Type "sendchar XBT 1" and then "OK" is back when it succeeds. (caution) Before entering this command, wait 10 seconds after power on the base unit
#X  (Attention) When type "sendchar #X" command, must be the "X" must be capital letter.		Read and Write BT parameters	[Read MAC address] Type"sendchar #X sme" and MAC address is read out (exp. sendchar #XXsme 0080 F08C FFD1) [Write MAC address] Type"sendchar #X sme **** *" and (note) part of **** should be set correct MAC address [Read the data of crystal of BT] Type"sendchar #X nc" and adjustment parameter of crystal of BT is read out (exp. #XXnc=0x1D) [Write the data of crystal of BT] Type"sendchar #X nc *" and adjustment parameter of crystal of BT is read out (note) part of ** should be set the adjusted value.

### Note:

For the command related with BT XBT and #X, the example of this, refer to **Things to Do after Replacing IC or X'tal** (P.62)

### 12.3. Adjustment Standard (Base Unit)

When connecting the simulator equipment for checking, please refer to below.

#### 12.3.1. Bottom View

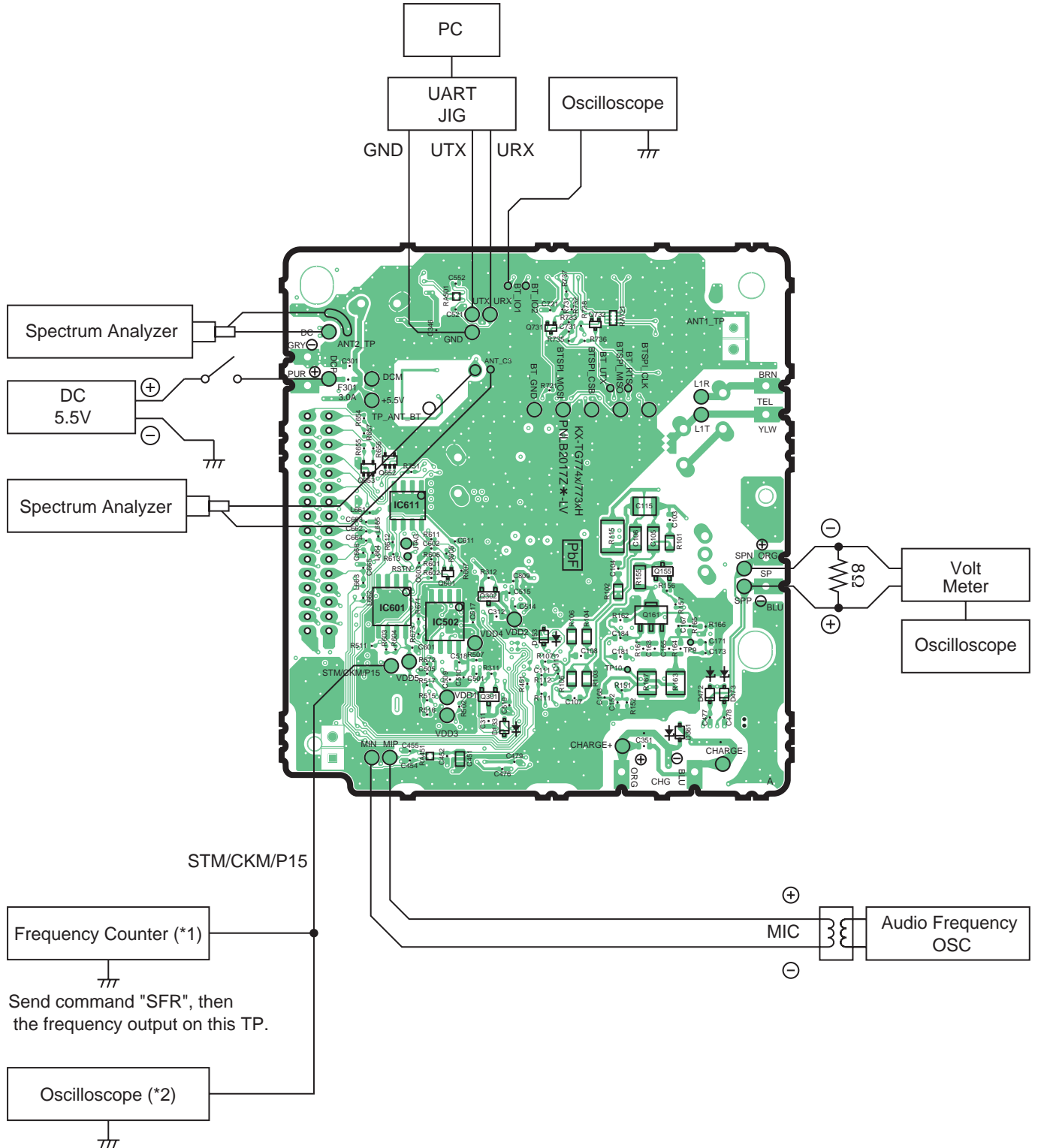

STM/CKM/P15

Frequency Counter (\*1)

Send command "SFR", then the frequency output on this TP.

Oscilloscope (\*2)

Start Monitor

- Note:**
- (\*1) is referred to No.2 of Check **Check Table for RF part** (P.42)
  - (\*2) is referred to **Power Supply Circuit/Reset Circuit** (P.14)

## 12.4. Adjustment Standard (Charger Unit)

When connecting the simulator equipment for checking, please refer to below.

### 12.4.1. Bottom View

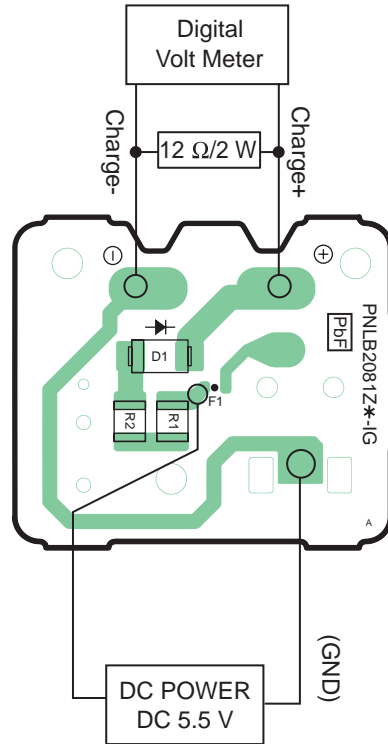

## 12.5. Adjustment Standard (Handset)

When connecting the simulator equipment for checking, please refer to below.

### 12.5.1. Component View

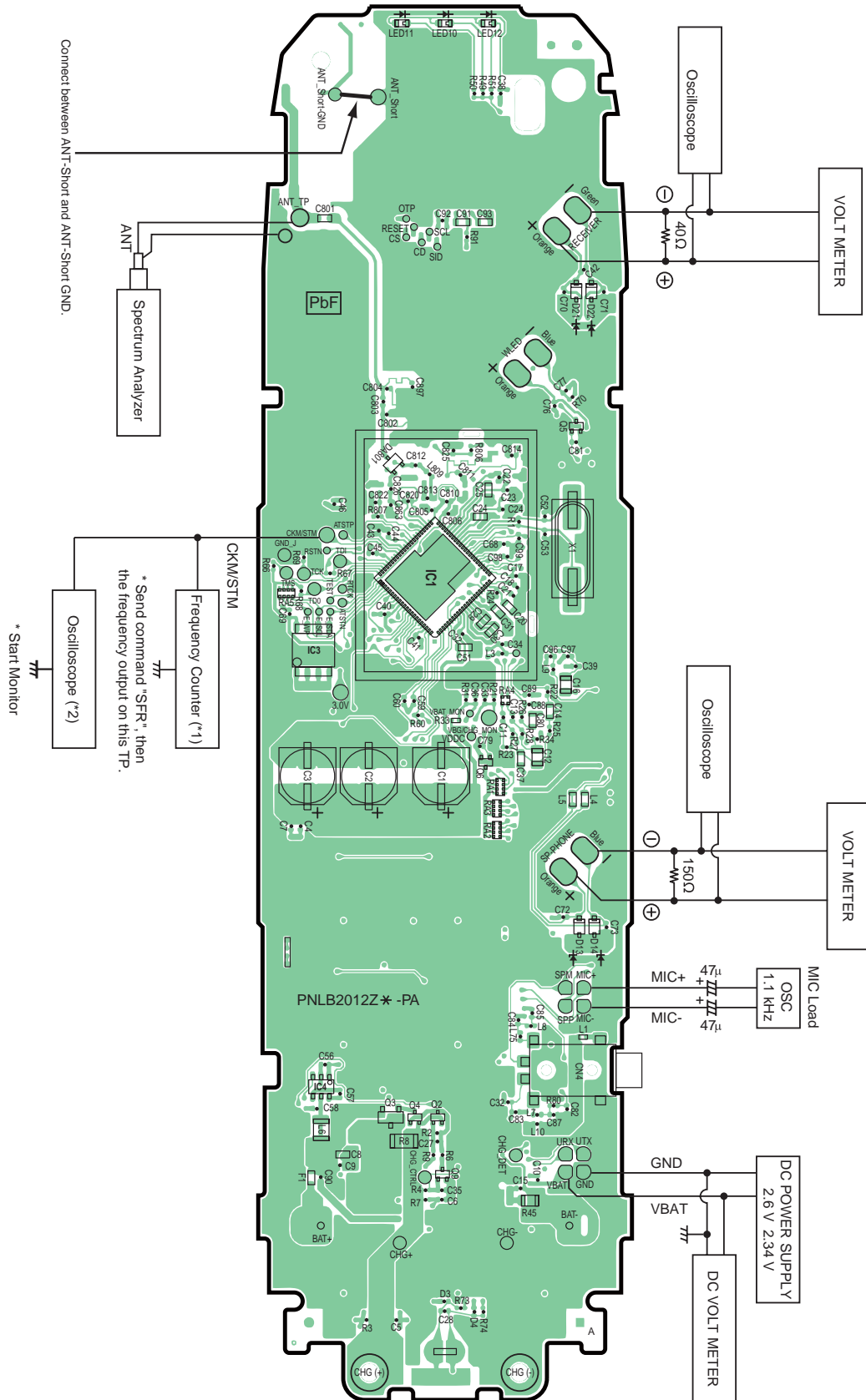

**Note:**

- (\*1) is referred to No.2 of Check Check Table for RF part (P.42)
- (\*2) is referred to Power Supply Circuit/Reset Circuit (P.22)

## 12.6. Things to Do after Replacing IC or X'tal

If repairing or replacing EEPROM and X'tal, it is necessary to download the required data such as Programming data or adjustment data, etc. in memory.

The set doesn't operate if it is not executed.

### 12.6.1. How to download the data

#### 12.6.1.1. Base Unit

First, operate the PC setting according to **The Setting Method of JIG (P.55)**.

Then download the appropriate data according to the following procedures.

Items		How to download/Required adjustment
BBIC(IC501)	Programming data is stored in memory.	1) Clock adjustment: Refer to Check Point (H).(*2)
EEPROM (IC611)	Adjusted parameter data is stored in memory. (country version batch file, default batch file, etc.)	1) Change the address "0001" of EEPROM to "55" to download the data. 2) Default batch file: Execute the command "default.bat". 3) Country version batch file: Execute the command "TG7741US_US_RevXXX_YYY.bat". (*1) 4) Clock adjustment
FLASH1 (IC601)	Voice prompt data is stored in memory. (vary depending on country version)	1) Wait more than 15 seconds after connecting the JIG Cable. 2) Execute the command "VPDL2011 -AA ZZZ.bin" (*1). (writing time: approx. 1 min (115200 bps).)
FLASH2 (IC502)	Program D/L	1) Make sure to connect the JIG cable and disconnect the DC Power in order to download the data. 2) Execute the command "flw441 *****.hex". 3) Connect the DC Power. 4) Press the PC Enter key once. 5) After a few minutes, "Successful upgrade" is displayed on the PC indicating downloading has finished. 6) Detach the JIG cable, then disconnect the DC Power. 7) Connect the DC Power. 8) Connect the JIG cable again, and execute the command "getchk", then confirm the checksum value is correct. . If the downloading fails, start again from step 1). 9) Default batch file: Execute the command "default.bat". 10) Country version batch file: Execute the command "TG7741US_US_RevXXX_YYY.bat". (*1) 11) Clock adjustment: Refer to Check Point (H). (*2)
X'tal (X1)	System clock	Clock adjustment data is in EEPROM, adjust the data again after replacing it. 1) Apply 5.5V between DCP ad DCM with DC power. 2) Input Command "sendchar sfr", then you can confirm the current value. 3) Check X'tal Frequency.(10.368MHz $\pm$ 41Hz). 4) If the frequency is not 10.368MHz $\pm$ 41Hz, adjust the frequency of CLK executing the command "sendchar sfr xx xx (where xx is the value)" so that the reading of the frequency counter is 10.368MHz $\pm$ 5Hz.

#### Note:

(\*1) XXX\_YYY: revision number, ZZZ:Voice prompt, AA: Baud rate(9600/19200/57600/115200)

"XXX\_YYY and "ZZZ" vary depending on the country version. You can find them in the batch file, PNZZ- mentioned in **The Setting Method of JIG (P.55)**.

**When adjust the frequency the BT Unit or write the MAC address to the BT Unit.**

	Item	Test command		Description
		Input	Echo back	
1	Power on	-	-	Wait 10seconds and connect JIG
2	Test mode	sendchar XBT 1 ␣ sendchar #X ts ␣	OK #XXTEST	Enter"XBT 1" and then "OK" is back when it succeeds to enter test mode.
3	Confirm a default value	sendchar #X nc ␣	#XXnc=0x1A	Confirm a default value before adjusting the frequency.
4	Adjust the frequency	sendchar #X b3 39 19 ␣ sendchar nc,, ␣	#XXTS ch=2441 pwr=19 #XXnc=0x,,	Adjust the frequency to "2441MHz $\pm$ 10kHz" by changing the value of, Test Point: ANT-C3, refer to <b>Bottom View (P.82)</b>

#### Note:

␣: Enter key

### 12.6.1.2. Handset

First, operate the PC setting according to **The Setting Method of JIG** (P.55).  
Then download the appropriate data according to the following procedures.

Items		How to download/Required adjustment
EEPROM (IC3)	Adjusted parameter data is stored in memory. (country version batch file, default batch file, etc.)	<ol style="list-style-type: none"> <li>1) Default batch file: Execute the command "default.bat".</li> <li>2) Default batch file (remaining): Execute the command "TGA470US_DEF_RevXXX_YYY.bat". (*2)</li> <li>3) Country version batch file: Execute the command "TGA470US_US_RevXXX_YYY.bat". (*2)</li> <li>4) Clock adjustment</li> <li>5) 2.35 V setting and battery low detection</li> </ol>
X'tal (X1)	System clock	<ol style="list-style-type: none"> <li>1) Apply 2.6V between BATT+ and BATT- with DC power.</li> <li>2) Input Command " sendchar sfr", then you can confirm the current value.</li> <li>3) Check X'tal Frequency.(13.824 MHz <math>\pm</math> 100 Hz).</li> <li>4) If the frequency is not 13.824 MHz <math>\pm</math> 100 Hz, adjust the frequency of CLK executing the command "sendchar sfr xx xx (where xx is the value)" so that the reading of the frequency counter is 13.824000 MHz <math>\pm</math> 5 Hz.</li> </ol>

**Note:**

(\*2) XXX\_YYY: revision number

"XXX\_YYY" vary depending on the country version. You can find them in the batch file, PNZZ- mentioned in **The Setting Method of JIG** (P.55).

## 12.7. Frequency Table

	Ch. (hex)	TX/RX Frequency (MHz)
Channel 0	00	1928.448
Channel 1	01	1926.720
Channel 2	02	1924.992
Channel 3	03	1923.264
Channel 4	04	1921.536

## 12.8. Bluetooth Frequency Table

Ch.	Frequency (MHz)	Ch.	Frequency (MHz)	Ch.	Frequency (MHz)
0	2402	33	2435	66	2468
1	2403	34	2436	67	2469
2	2404	35	2437	68	2470
3	2405	36	2438	69	2471
4	2406	37	2439	70	2472
5	2407	38	2440	71	2473
6	2408	39	2441	72	2474
7	2409	40	2442	73	2475
8	2410	41	2443	74	2476
9	2411	42	2444	75	2477
10	2412	43	2445	76	2478
11	2413	44	2446	77	2479
12	2414	45	2447	78	2480
13	2415	46	2448		
14	2416	47	2449		
15	2417	48	2450		
16	2418	49	2451		
17	2419	50	2452		
18	2420	51	2453		
19	2421	52	2454		
20	2422	53	2455		
21	2423	54	2456		
22	2424	55	2457		
23	2425	56	2458		
24	2426	57	2459		
25	2427	58	2460		
26	2428	59	2461		
27	2429	60	2462		
28	2430	61	2463		
29	2431	62	2464		
30	2432	63	2465		
31	2433	64	2466		
32	2434	65	2467		

# 13 Miscellaneous

## 13.1. How to Replace the LLP (Leadless Leadframe Package) IC

### Note:

This description is only applied on the model with Shield case.

### 13.1.1. Preparation

- PbF (: Pb free) Solder
- Soldering Iron  
Tip Temperature of 700 °F ± 20 °F (370 °C ± 10 °C)

#### Note:

We recommend a 30 to 40 Watt soldering iron. An expert may be able to use a 60 to 80 Watt iron where someone with less experience could overheat and damage the PCB foil.

- Hot Air Desoldering Tool  
Temperature: 608 °F ± 68 °F (320 °C ± 20 °C)

### 13.1.2. Caution

- To replace the IC efficiently, choose the right sized nozzle of the hot air desoldering tool that matches the IC package.
- Be careful about the temperature of the hot air desoldering tool not to damage the PCB and/or IC.

### 13.1.3. How to Remove the IC

1. Heat the IC with a hot air desoldering tool through the P.C.Board.

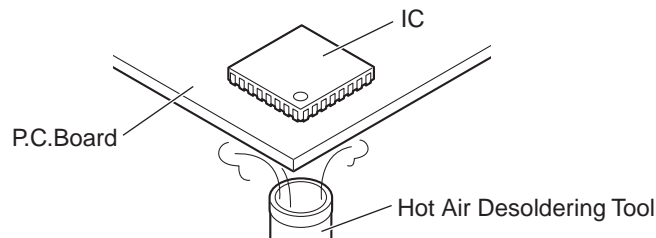

2. Pick up the IC with tweezers, etc. when the solder is melted completely.

#### Note:

- Be careful not to touch the peripheral parts with tweezers, etc. They are unstable.

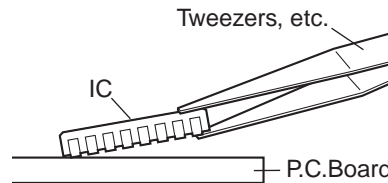

When it is hard to melt the solder completely, heat it with a hot air desoldering tool through the IC besides through the P.C.Board.

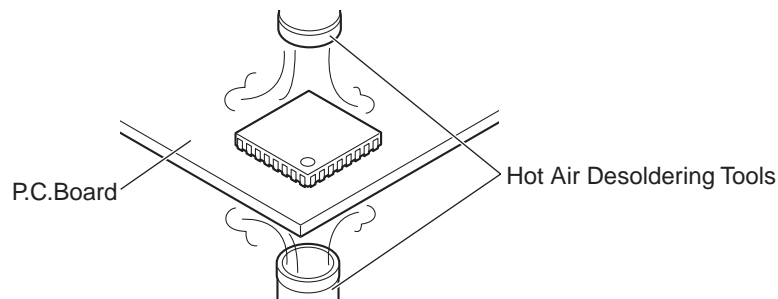

3. After removing the IC, clean the P.C.Board of residual solder.

### 13.1.4. How to Install the IC

1. Place the solder a little on the land where the radiation GND pad on IC bottom is to be attached.

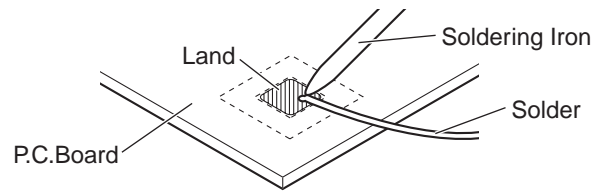

2. Place the solder a little on the land where IC pins are to be attached, then place the IC.

**Note:**

- When placing the IC, the positioning should be done very carefully.

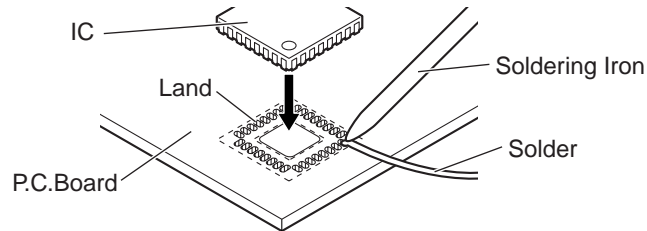

3. Heat the IC with a hot air desoldering tool through the P.C.Board until the solder on IC bottom is melted.

**Note:**

- Be sure to place it precisely, controlling the air volume of the hot air desoldering tool.

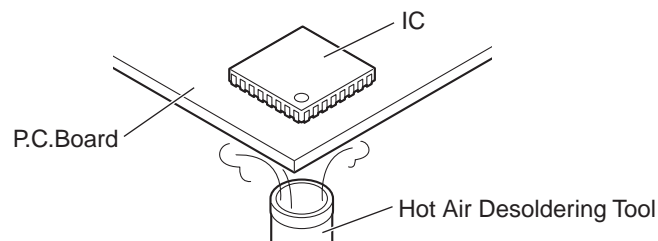

4. After soldering, confirm there are no short and open circuits with visual inspection.

## 13.2. How to Replace the Flat Package IC

Even if you do not have the special tools (for example, a spot heater) to remove the Flat IC, with some solder (large amount), a soldering iron and a cutter knife, you can easily remove the ICs that have more than 100 pins.

### 13.2.1. Preparation

- PbF (: Pb free) Solder
- Soldering Iron

Tip Temperature of 700 °F ± 20 °F (370 °C ± 10 °C)

**Note:** We recommend a 30 to 40 Watt soldering iron. An expert may be able to use a 60 to 80 Watt iron where someone with less experience could overheat and damage the PCB foil.

- Flux

Recommended Flux: Specific Gravity → 0.82.

Type → RMA (lower residue, non-cleaning type)

**Note:** See **About Lead Free Solder (PbF: Pb free)** (P.4)

### 13.2.2. How to Remove the IC

1. Put plenty of solder on the IC pins so that the pins can be completely covered.

**Note:**

If the IC pins are not soldered enough, you may give pressure to the P.C. board when cutting the pins with a cutter.

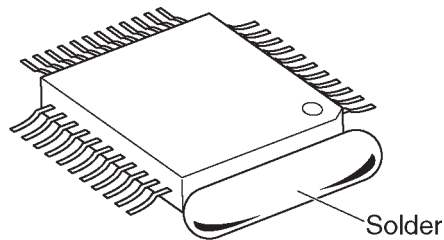

2. Make a few cuts into the joint (between the IC and its pins) first and then cut off the pins thoroughly.

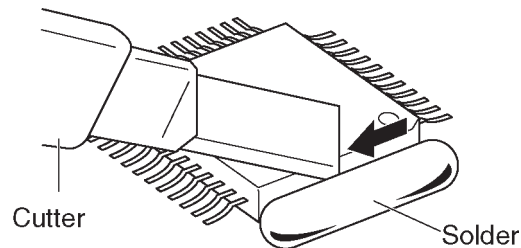

3. While the solder melts, remove it together with the IC pins.

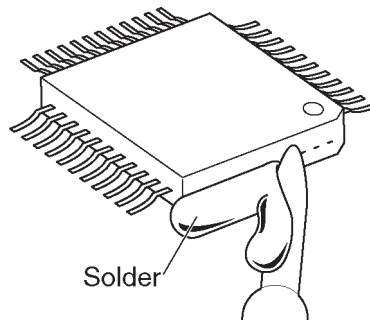

When you attach a new IC to the board, remove all solder left on the board with some tools like a soldering wire. If some solder is left at the joint on the board, the new IC will not be attached properly.

### 13.2.3. How to Install the IC

1. Temporarily fix the FLAT PACKAGE IC, soldering the two marked pins.

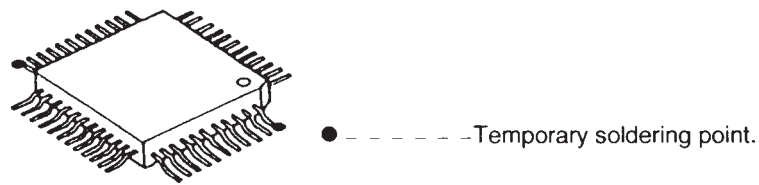

\*Check the accuracy of the IC setting with the corresponding soldering foil.

2. Apply flux to all pins of the FLAT PACKAGE IC.

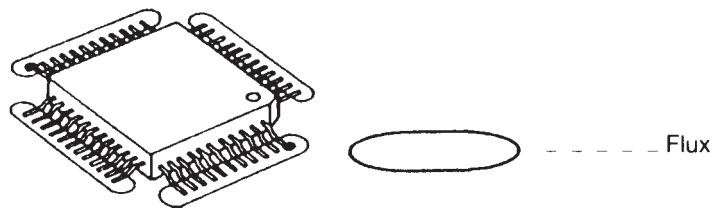

3. Solder the pins, sliding the soldering iron in the direction of the arrow.

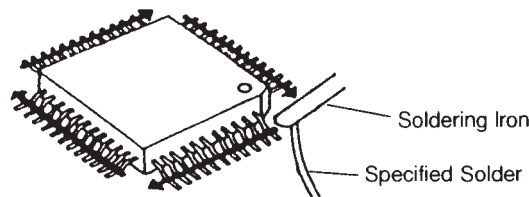





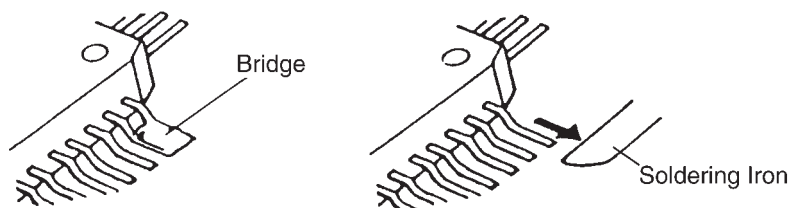

### 13.2.4. How to Remove a Solder Bridge

1. Lightly resolder the bridged portion.
2. Remove the remaining solder along the pins using a soldering iron as shown in the figure below.

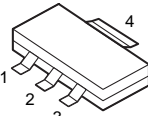
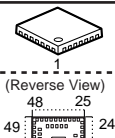
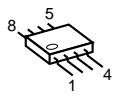
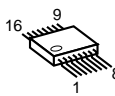

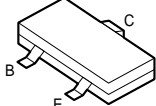
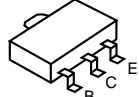
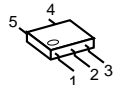
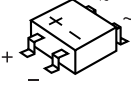
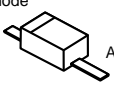

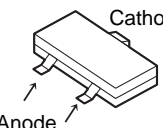
### 13.3. Terminal Guide of the ICs, Transistors and Diodes

#### 13.3.1. Base Unit

 <p>C0DBEY00102</p>	 <p>(Reverse View) C1CB00003663</p>	 <p>PNWI1TG7741H PNWI2TG7741H PNWI3TG7741H</p>	 <p>C0JBAQ000247</p>	 <p>B1ACGP000008</p>
 <p>B1ABDM000001, B1ADGE000012 2SC6054JSL, DRC9113Z0L 2SA1576S, B1GBCFYY0020</p>	 <p>DSC7003S0L</p>	 <p>PSVTUMG11NTR</p>	 <p>PQVDMD5S</p>	
 <p>DA2J10100L</p>	 <p>PQVDPTZT2530</p>	 <p>B0ECKM000008</p>	 <p>B0DDCD000001</p>	 <p>B3AAB0000347 LNJ237W82RA</p>
 <p>(Reverse View) B3ABB0000331</p>				

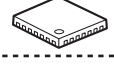
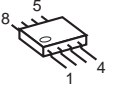
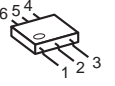
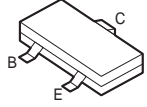
#### 13.3.2. Handset

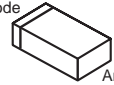
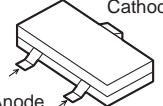
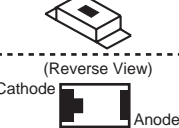
 <p>(Reverse View) C2HBCY000081</p>	 <p>PNWITGA470BR</p>	 <p>C0DBZY000357</p>	 <p>B1ADCF000040 DRC9113Z0L 2SC6054JSL</p>	 <p>B1ABGE000011</p>
 <p>B0BC4R3A0006</p>	 <p>B0DDCD000001</p>	 <p>(Reverse View) B3ACB0000190</p>		

#### 13.3.3. Charger

 <p>B0ECKM000008</p>
---

# 14 Schematic Diagram

## 14.1. For Schematic Diagram

### 14.1.1. Base Unit (Schematic Diagram (Base Unit\_Main))

**Notes:**

1. DC voltage measurements are taken with voltmeter from the negative voltage line.

Important Safety Notice:  
Components identified by  $\triangle$  mark have special characteristics important for safety. When replacing any of these components, use only the manufacture's specified parts.

2. The schematic diagrams may be modified at any time with the development of new technology.

### 14.1.2. Handset (Schematic Diagram (Handset\_Main))

**Notes:**

1. DC voltage measurements are taken with an oscilloscope or a tester with a ground.
2. The schematic diagrams may be modified at any time with the development of new technology.

### 14.1.3. Charger Unit (Schematic Diagram (Charger Unit))

**Notes:**

1. DC voltage measurements are taken with voltmeter from the negative voltage line.

Important Safety Notice:  
Components identified by  $\triangle$  mark have special characteristics important for safety. When replacing any of these components, use only the manufacture's specified parts.

2. The schematic diagrams may be modified at any time with the development of new technology.



REFERENCE  
 1XX : TEL LINE  
 3XX : POWER, CHARGE  
 4XX : MIC, SP  
 5XX : BBIC  
 6XX : FLASH, EEPROM, KEY, LCD  
 7XX : FOR DK/BT  
 8XX : RF

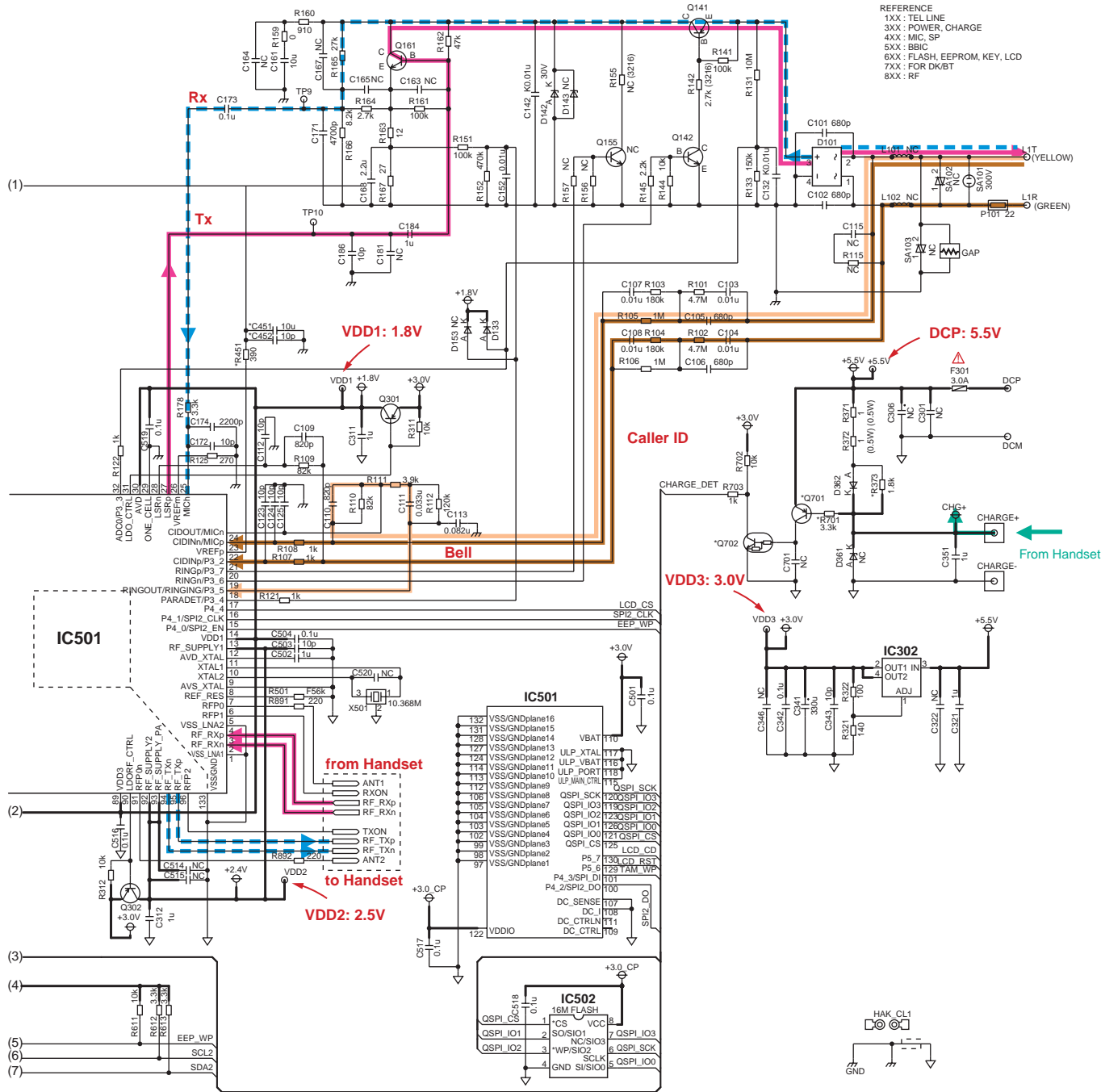

NC: No Components

KX-TG7741/7742/7743 SCHEMATIC DIAGRAM (Base Unit\_Main)

### 14.3. Schematic Diagram (Base Unit\_RF)

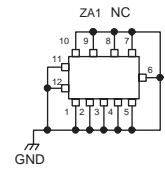
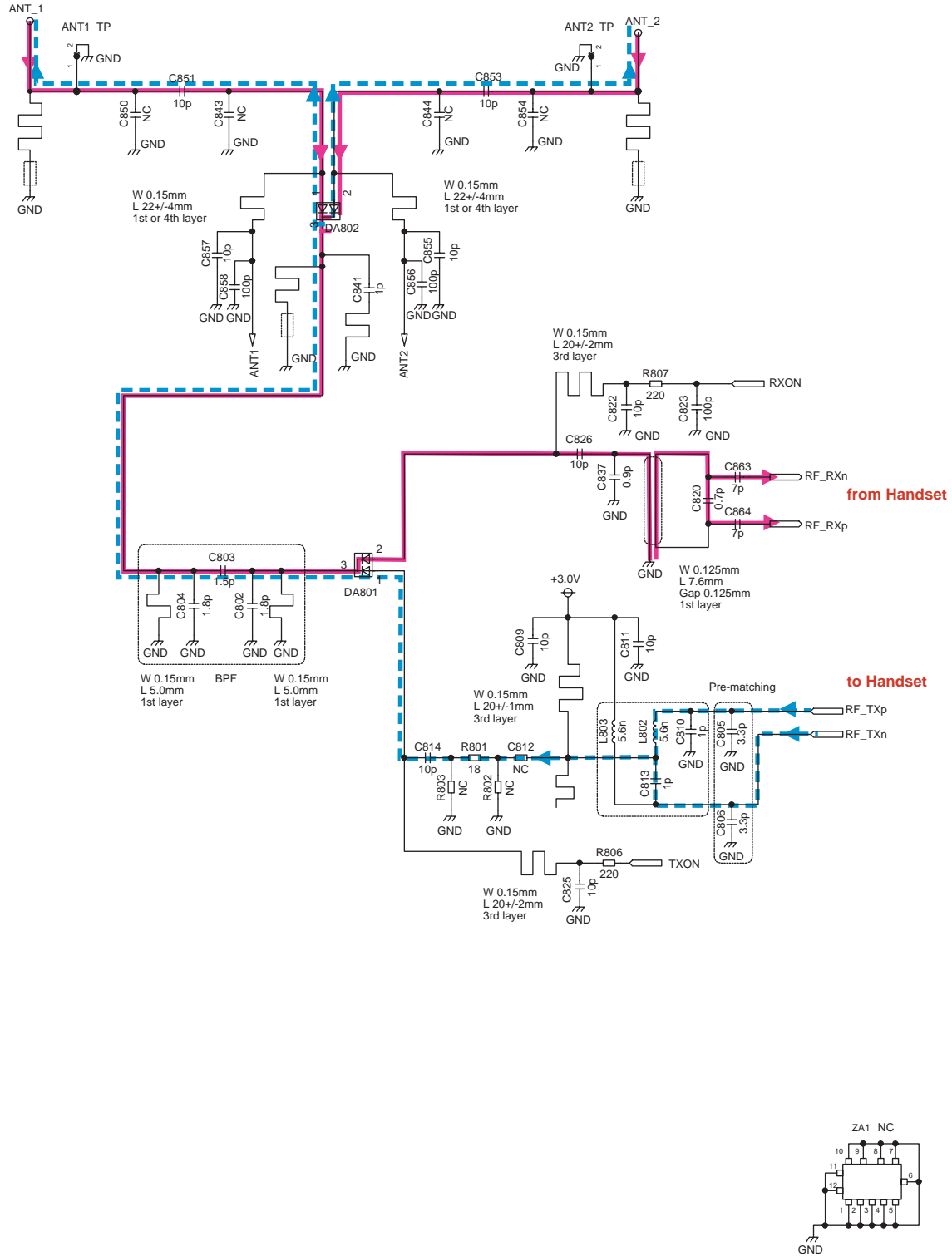

NC: No Components

KX-TG7741/7742/7743 SCHEMATIC DIAGRAM (Base Unit\_RF)

# 14.4. Schematic Diagram (Base Unit\_Operation)

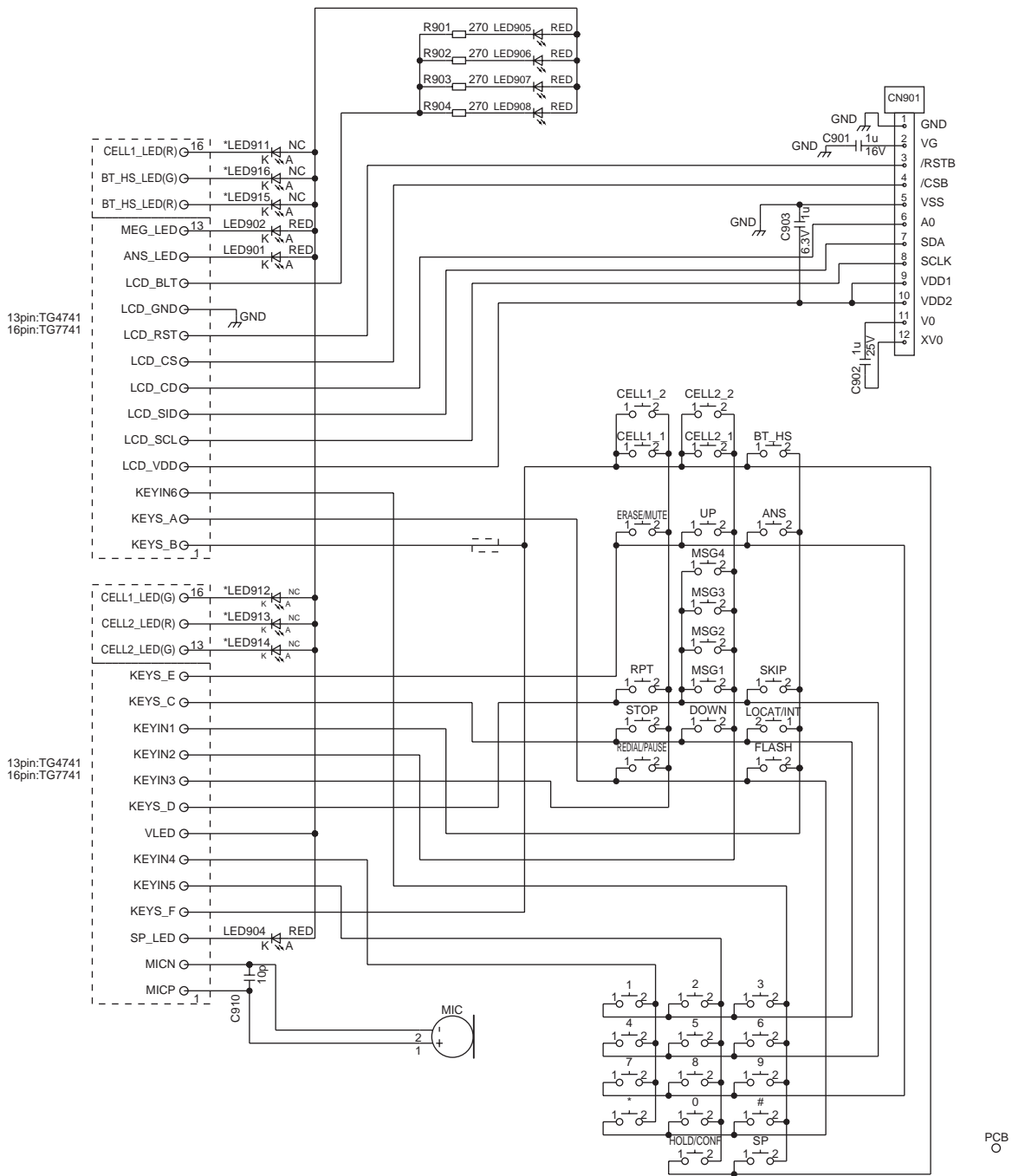

FOR TG7741, TG4741

CT2 CT1 CARBON\_TEST

NC: No Components

KX-TG7741/7742/7743 SCHEMATIC DIAGRAM (Base Unit\_Operation)





## 14.6. Schematic Diagram (Handset\_LED)

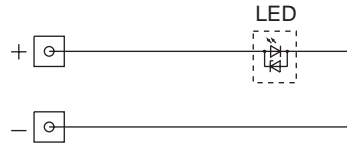

KX-TGA470 SCHEMATIC DIAGRAM (Handset\_LED)

## 14.7. Schematic Diagram (Charger Unit)

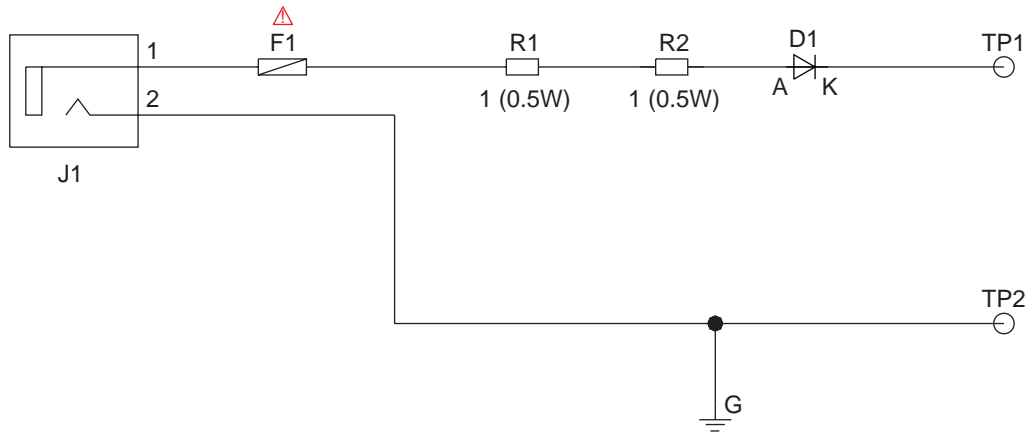

SCHEMATIC DIAGRAM (Charger Unit)

**Memo**

# 15 Printed Circuit Board

## 15.1. Circuit Board (Base Unit\_Main)

### 15.1.1. Component View

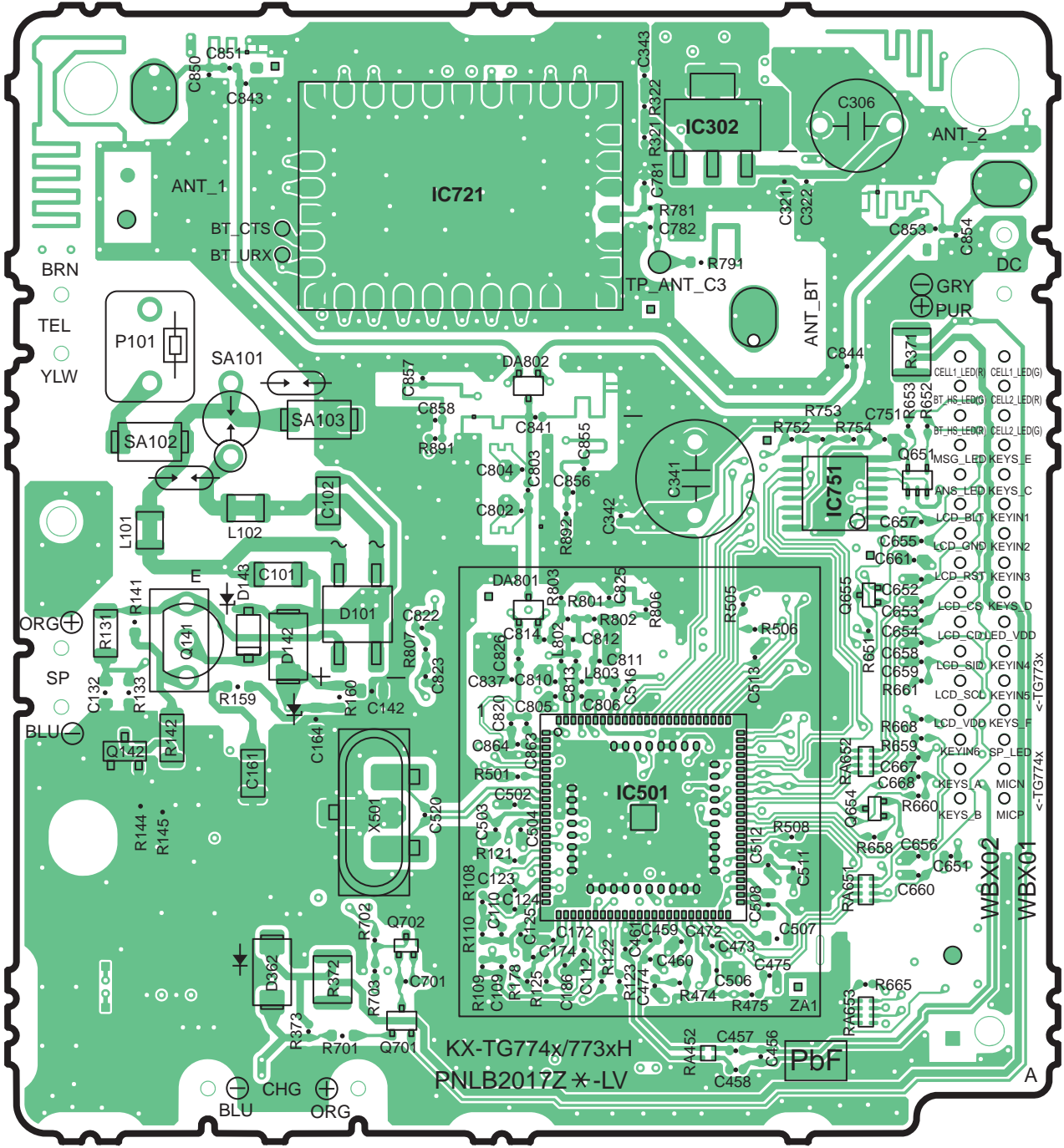

KX-TG7741/7742/7743 CIRCUIT BOARD (Base Unit\_Main (Component View))

### 15.1.2. Bottom View

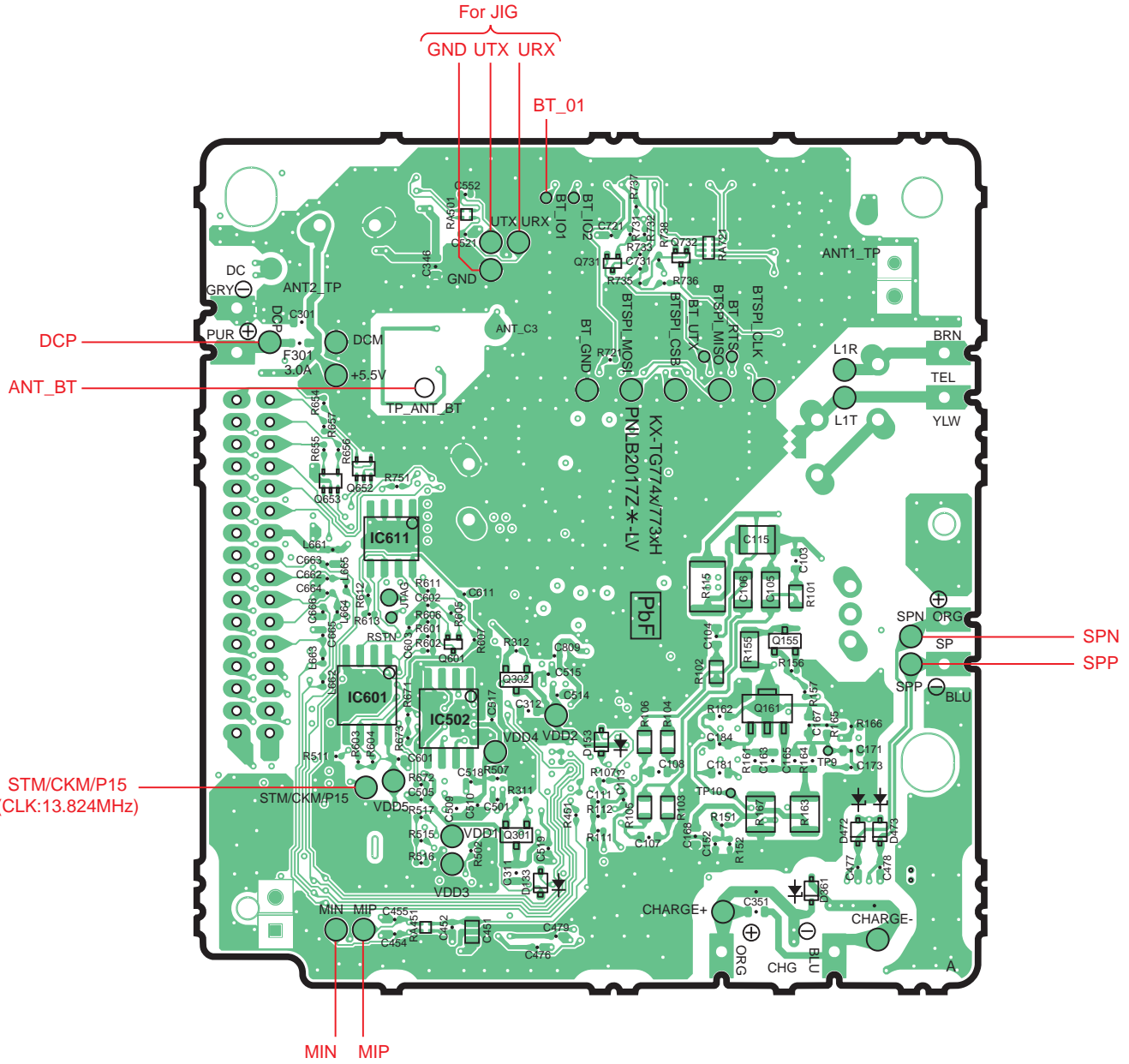

KX-TG7741/7742/7743 CIRCUIT BOARD (Base Unit\_Main (Bottom View))

## 15.2. Circuit Board (Base Unit\_Operation)

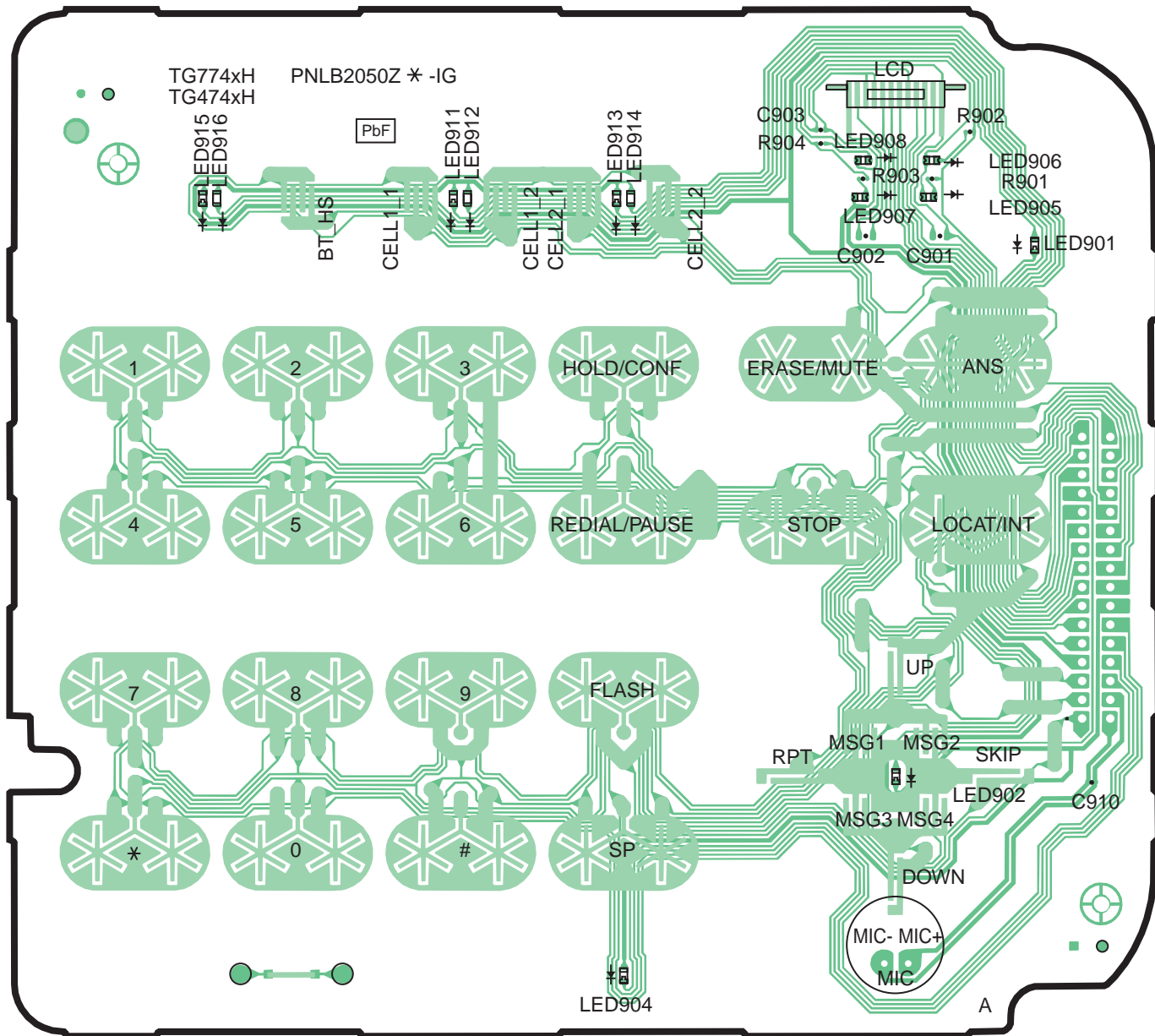

KX-TG7741/7742/7743 CIRCUIT BOARD (Base Unit\_Operation (Component View))

# 15.3. Circuit Board (Handset\_Main)

## 15.3.1. Component View

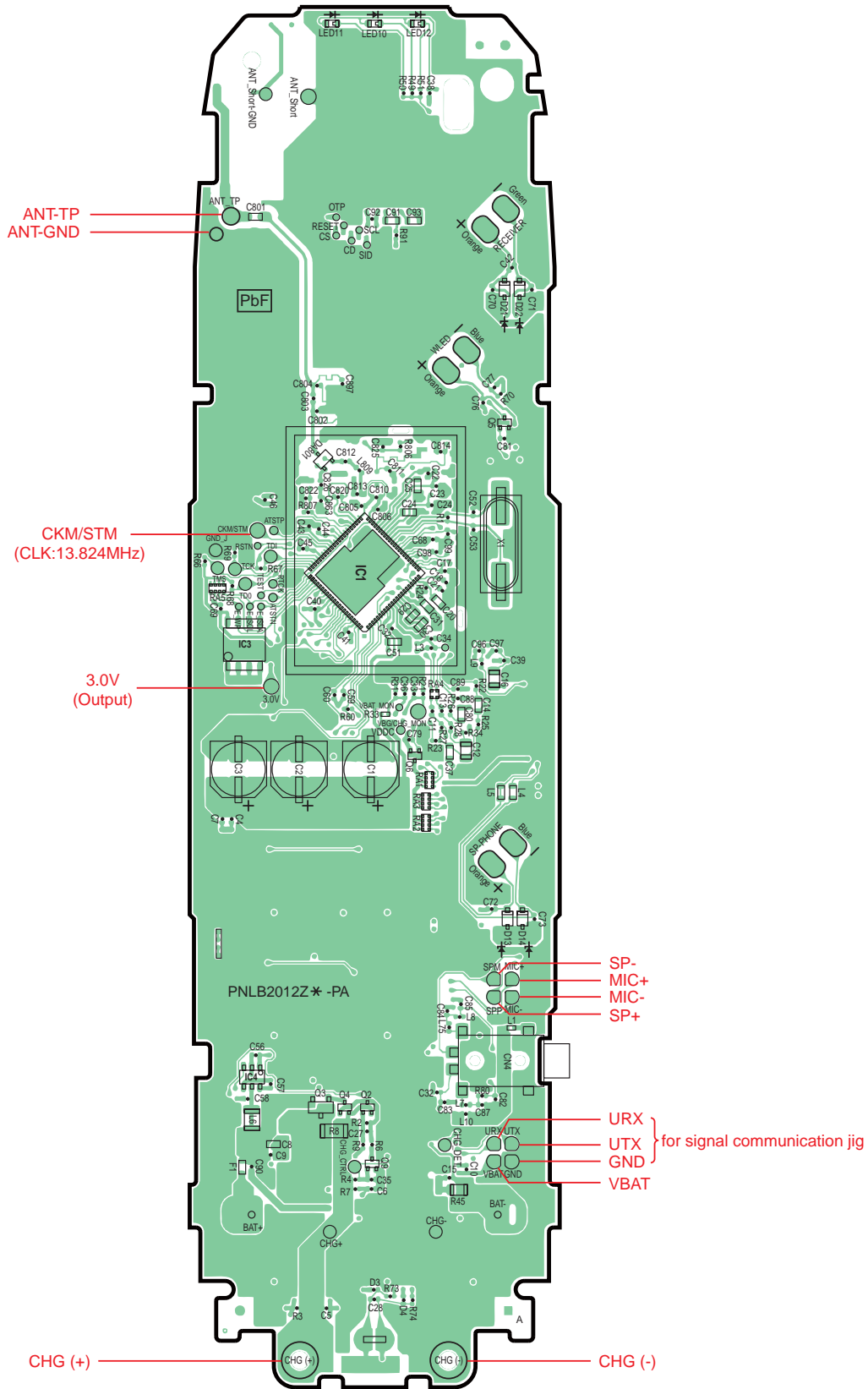

KX-TGA470 CIRCUIT BOARD (Handset\_Main (Component View))

### 15.3.2. Bottom View

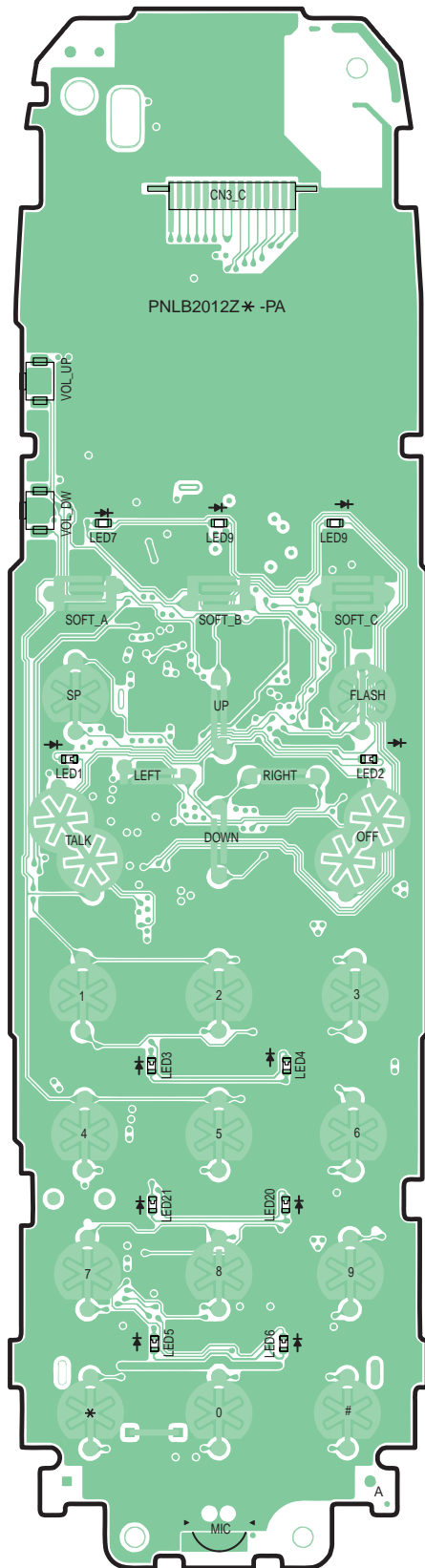

KX-TGA470 CIRCUIT BOARD (Handset\_Main (Bottom View))

## 15.4. Circuit Board (Handset\_LED)

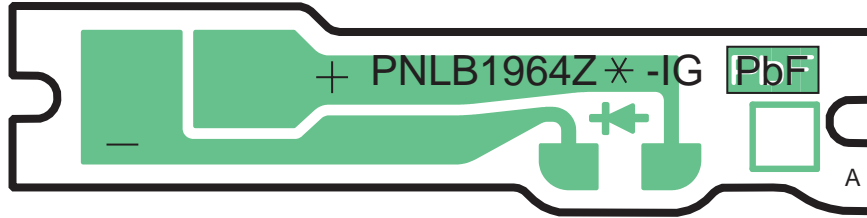

KX-TGA470 CIRCUIT BOARD (Handset\_LED (Component View))

# 15.5. Circuit Board (Charger Unit)

## 15.5.1. Component View

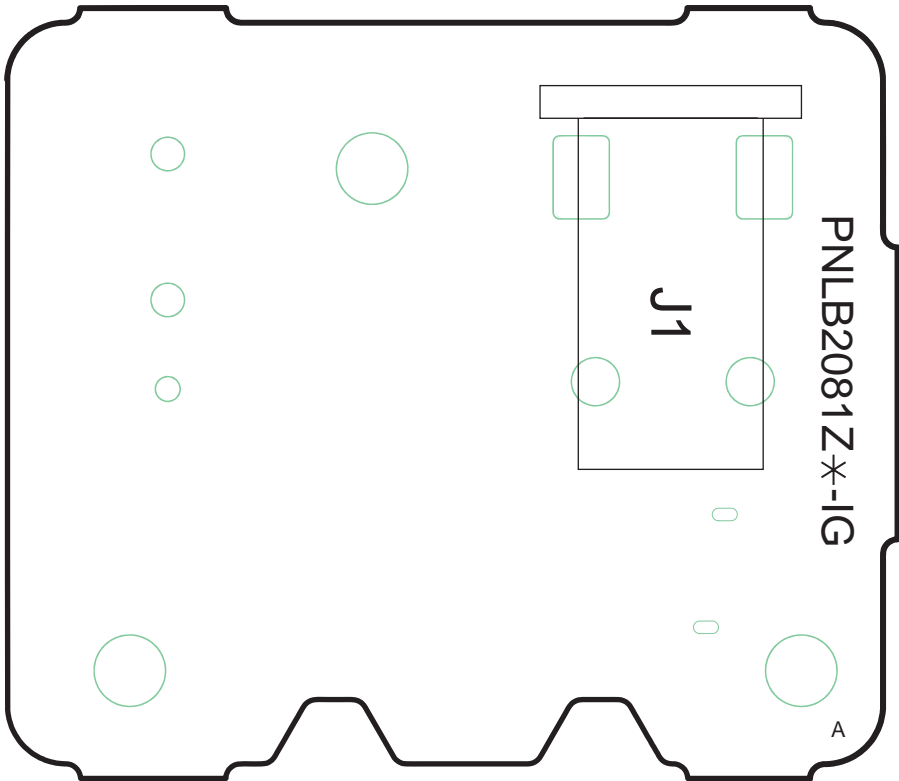

CIRCUIT BOARD (Charger Unit (Component View))

## 15.5.2. Bottom View

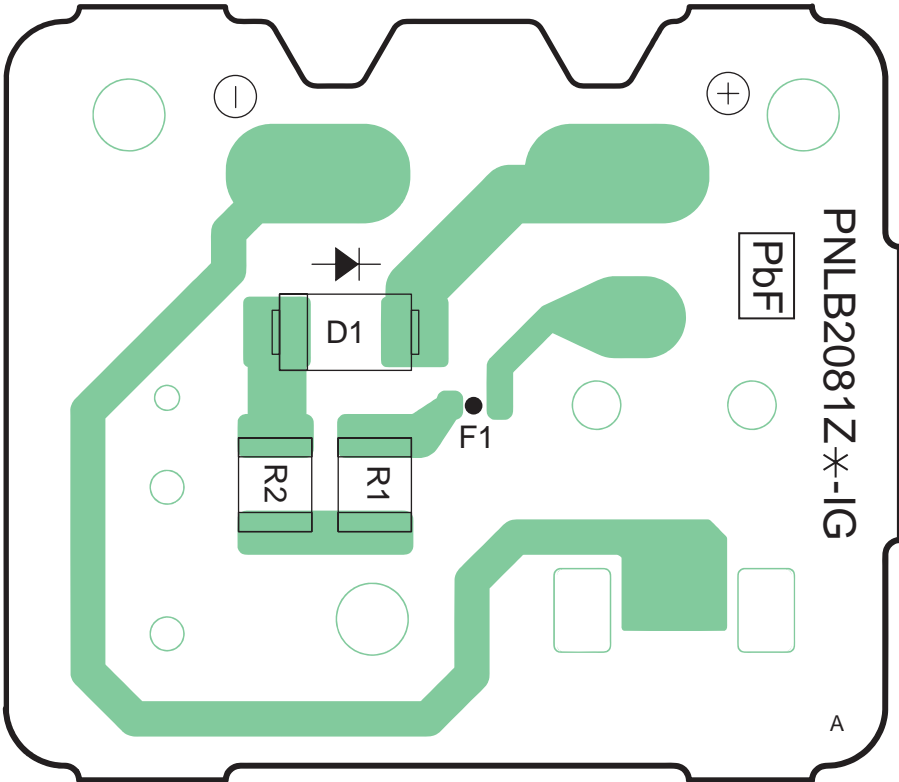

CIRCUIT BOARD (Charger Unit (Bottom View))

# 16 Exploded View and Replacement Parts List

## 16.1. Cabinet and Electrical Parts (Base Unit)

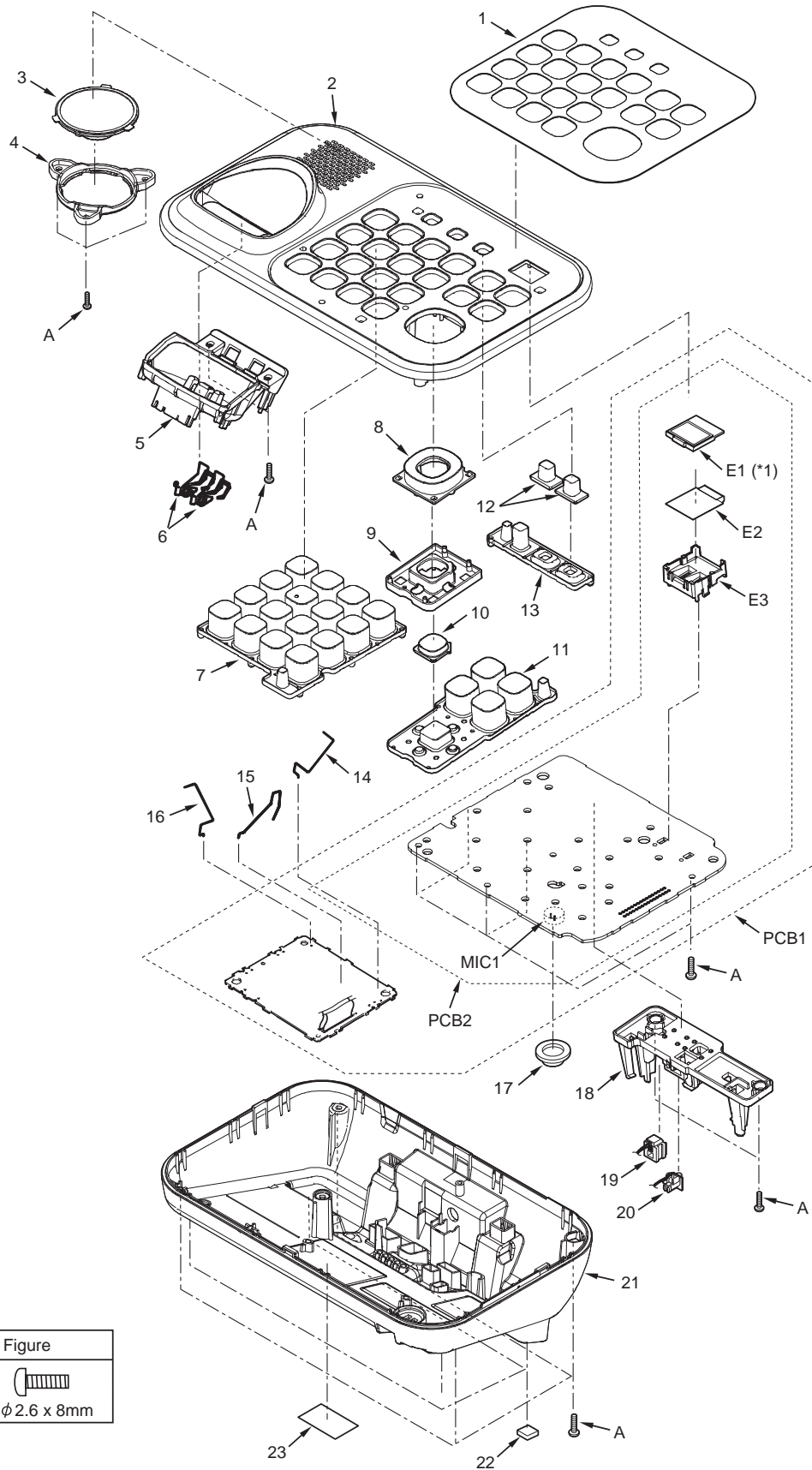

Ref.No.	Figure
A	 φ2.6 x 8mm

**Note:**

(\*1) This cable is fixed by welding. Refer to **How to Replace the Base unit LCD (P.52)**.

## 16.2. Cabinet and Electrical Parts (Handset)

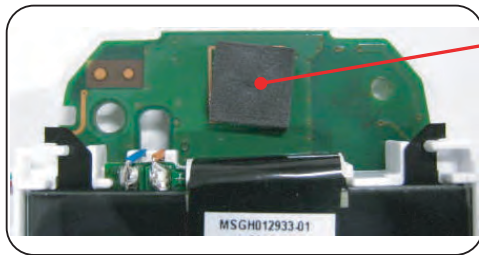

CUSHION RUBBER  
\*STICK IT WITHIN THE FRAMEWORK ON P.C.B.

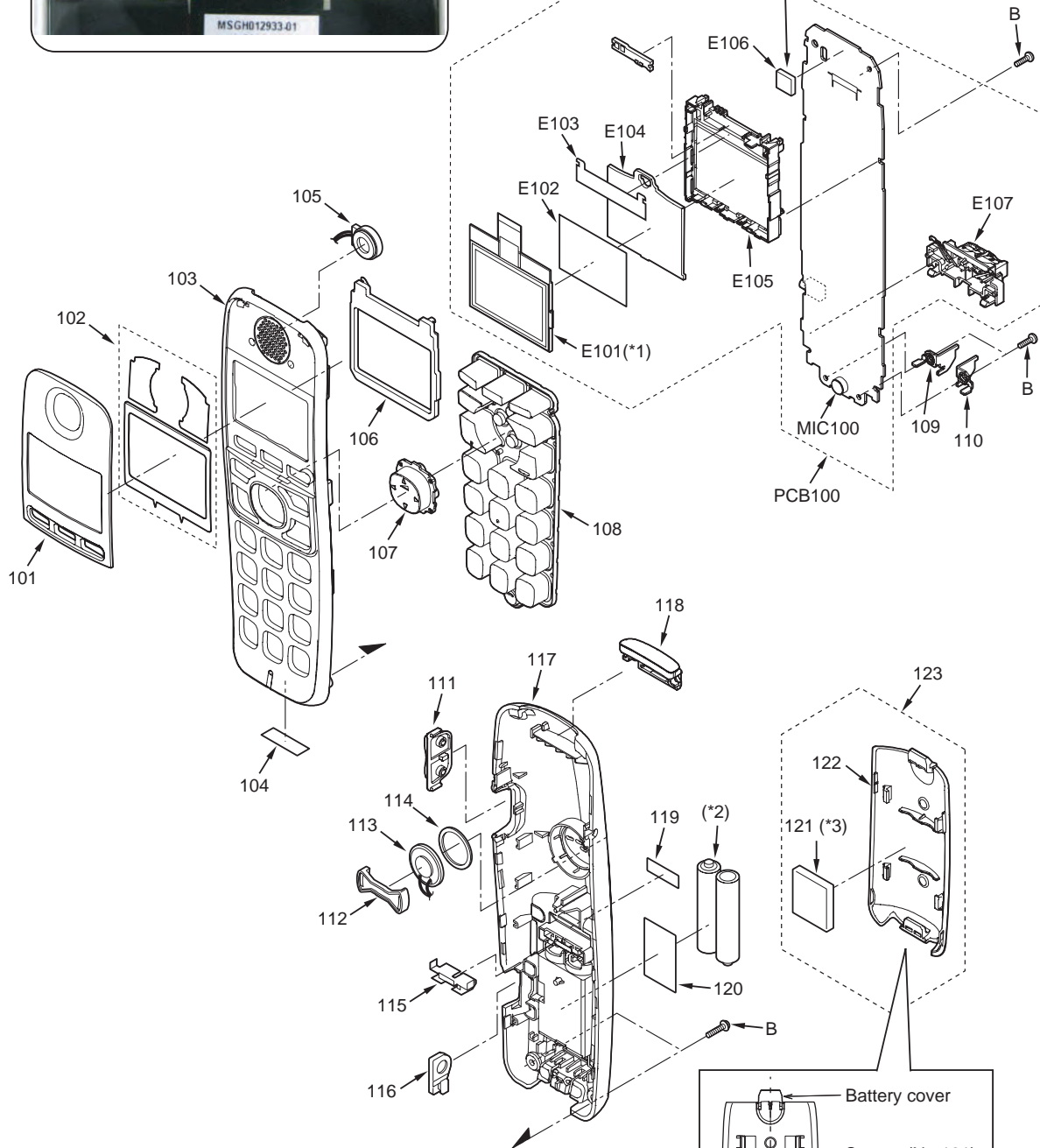

Ref.No.	Figure
B	 φ2×8 mm

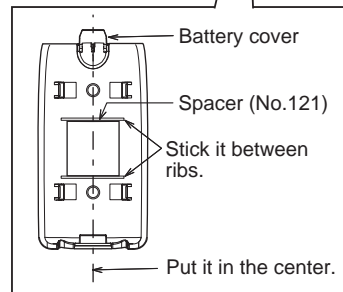

**Note:**

- (\*1) This cable is fixed by welding. Refer to **How to Replace the Handset LCD (P.54)**.
- (\*2) The rechargeable Ni-MH battery HHR-4DPA is available through sales route of Panasonic.
- (\*3) Attach the SPACER (No. 121) to the exact location described above.

### 16.3. Cabinet and Electrical Parts (Charger Unit)

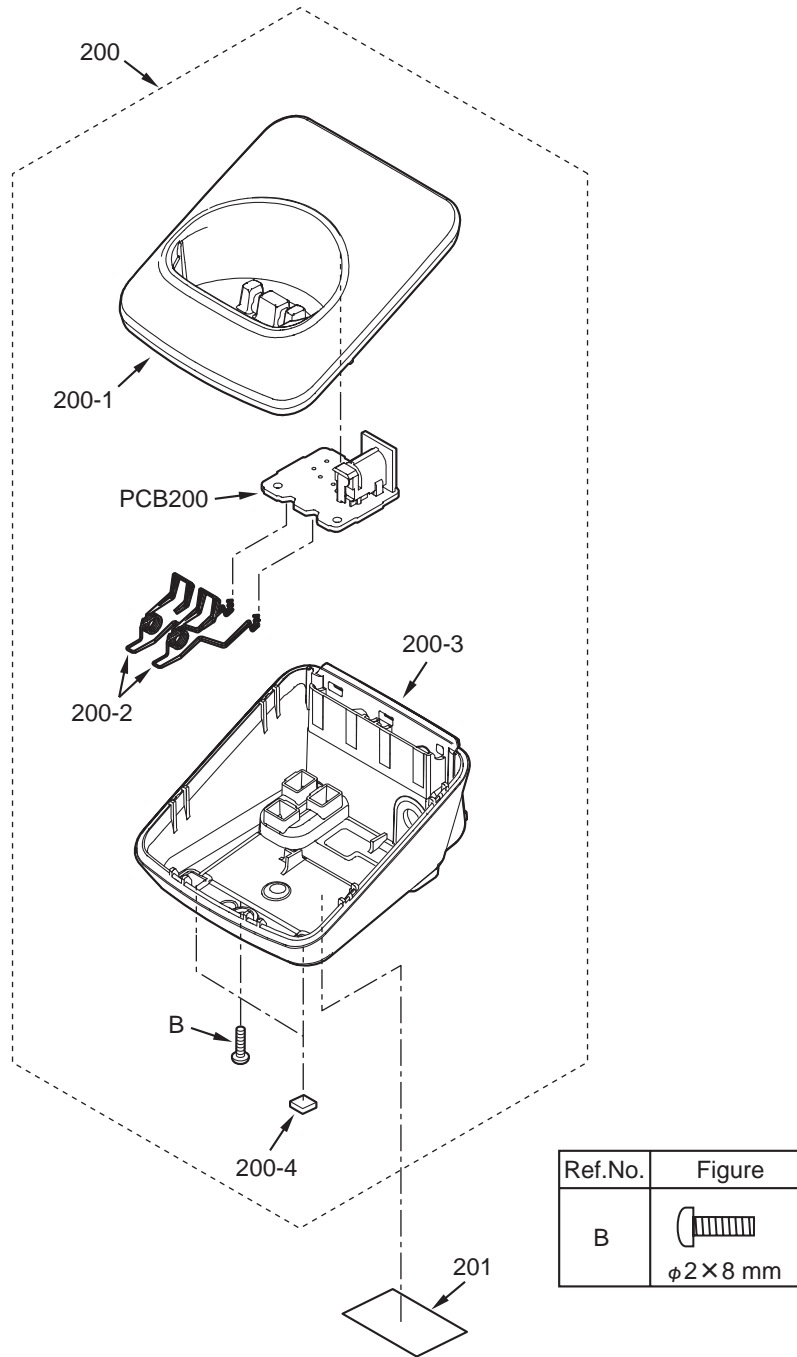

Ref.No.	Figure
B	 φ2×8 mm

# 16.4. Accessories and Packing Materials

## 16.4.1. KX-TG7741S

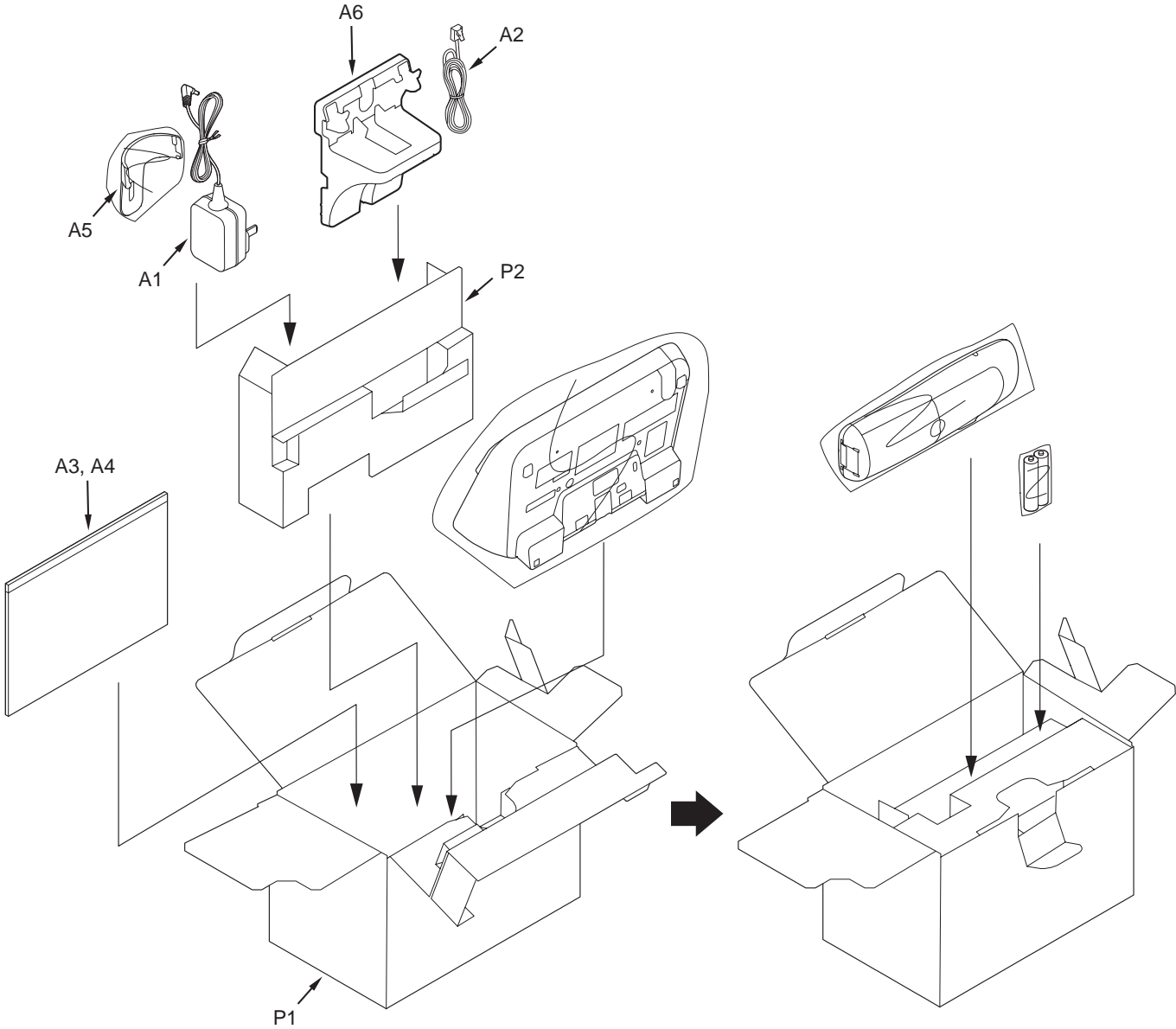

### 16.4.2. KX-TG7742S

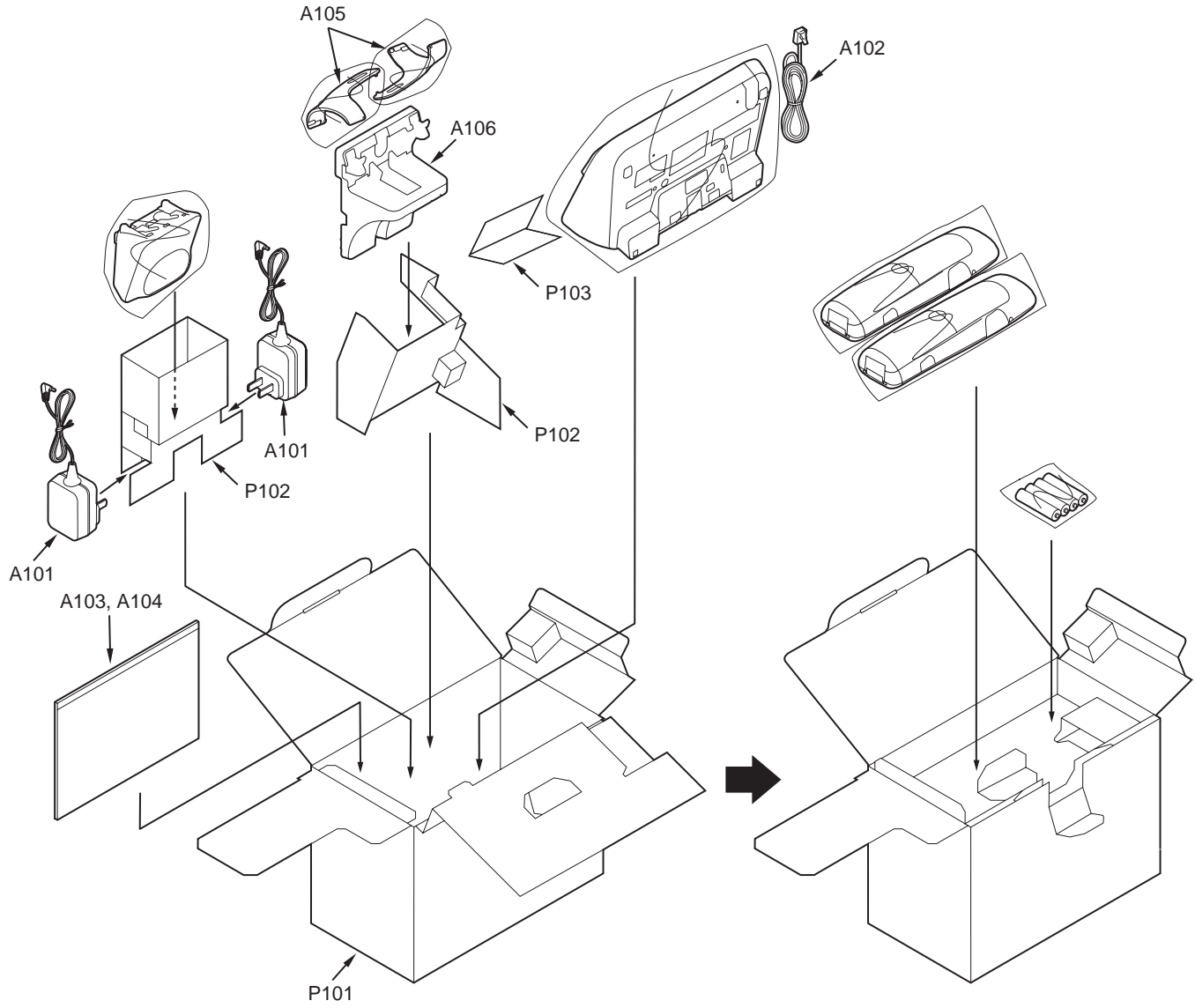

16.4.3. KX-TG7743S

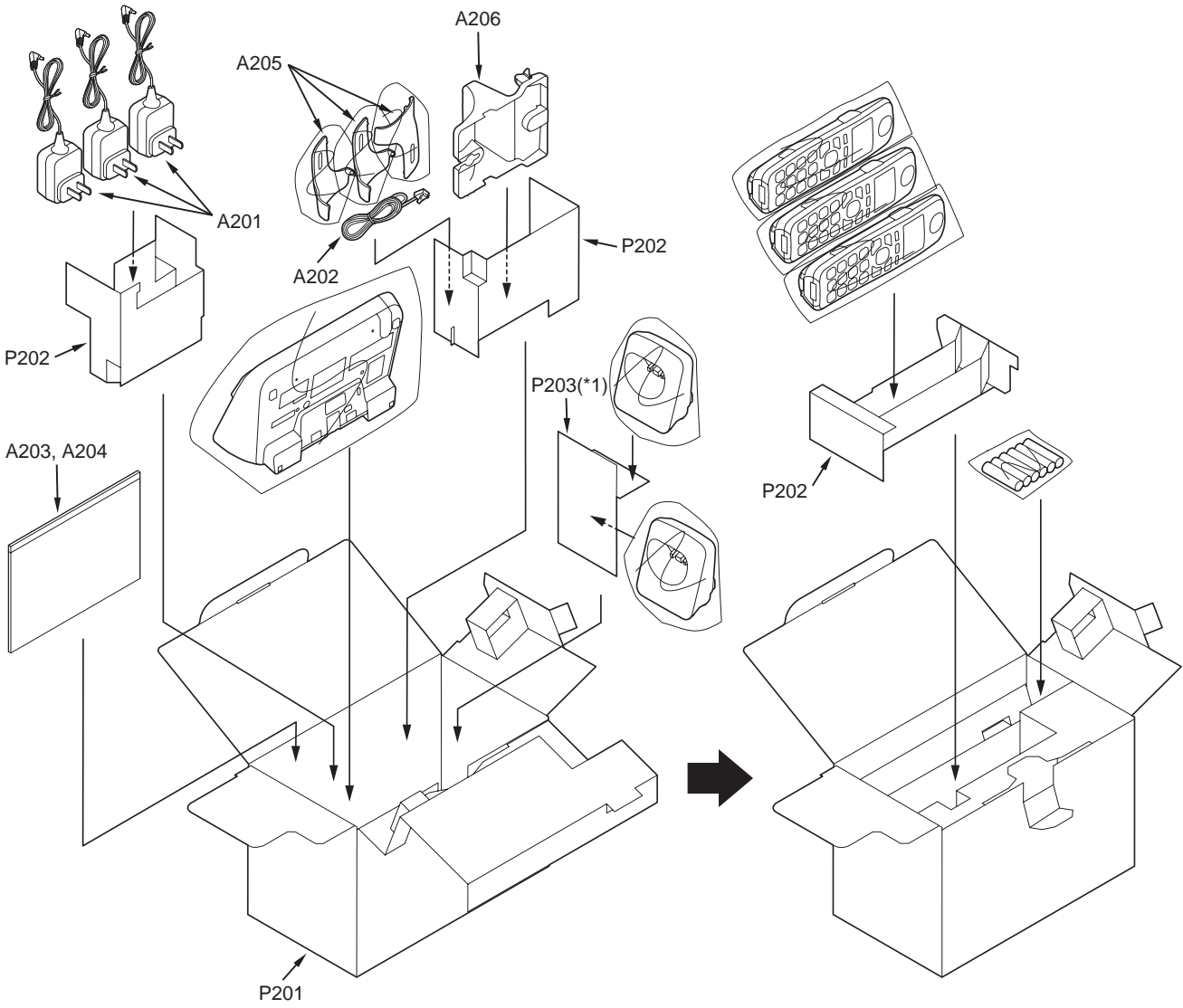

Note:  
(\*1) This pad is a piece of Ref No.P201 (GIFT BOX).

### 16.4.4. KX-TGA470S

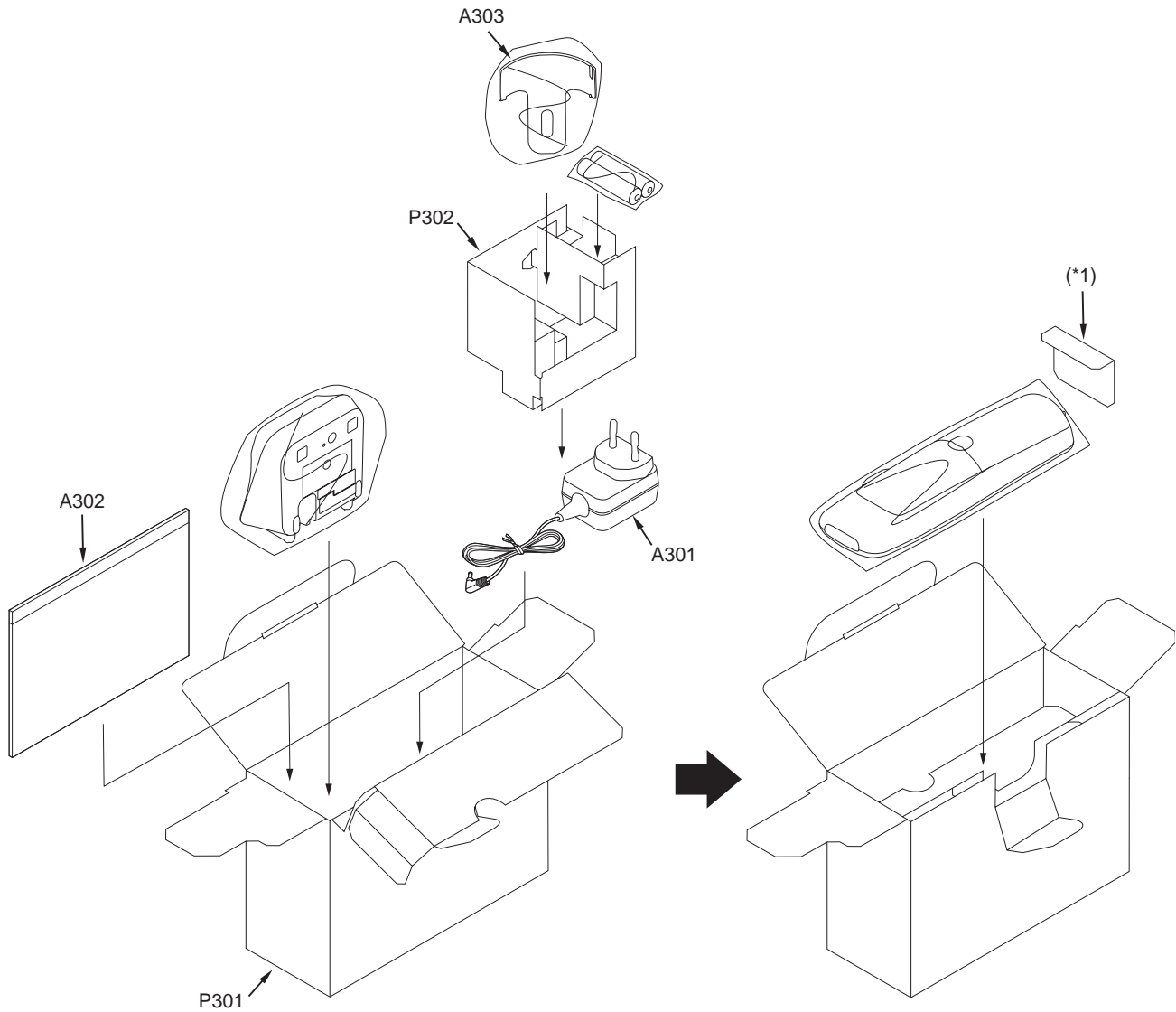

Note:

(\*1) This pad is a piece of Ref No.P301 (GIFT BOX).

## 16.5. Replacement Parts List

### 1. RTL (Retention Time Limited)

#### Note:

The "RTL" marking indicates that its Retention Time is Limited.

When production is discontinued, this item will continue to be available only for a specific period of time.

This period of time depends on the type of item, and the local laws governing parts and product retention. At the end of this period, the item will no longer be available.

### 2. Important safety notice

Components identified by the  $\Delta$  mark indicates special characteristics important for safety. When replacing any of these components, only use specified manufacturer's parts.

### 3. The S mark means the part is one of some identical parts.

For that reason, it may be different from the installed part.

### 4. ISO code (Example: ABS-94HB) of the remarks column shows quality of the material and a flame resisting grade about plastics.

### 5. RESISTORS & CAPACITORS

Unless otherwise specified;

All resistors are in ohms ( $\Omega$ ) k=1000 $\Omega$ , M=1000k $\Omega$

All capacitors are in MICRO FARADS ( $\mu$ F) p= $\mu$  $\mu$ F

\*Type & Wattage of Resistor

#### Type

ERC:Solid	ERX:Metal Film	PQ4R:Chip
ERDS:Carbon	ERG:Metal Oxide	ERS:Fusible Resistor
ERJ:Chip	ER0:Metal Film	ERF:Cement Resistor

#### Wattage

10,16:1/8W	14,25:1/4W	12:1/2W	1:1W	2:2W	3:3W
------------	------------	---------	------	------	------

\*Type & Voltage Of Capacitor

#### Type

ECFD:Semi-Conductor	ECCD,ECKD,ECBT,F1K,ECUV:Ceramic
ECQS:Styrol	ECQE,ECQV,ECQG:Polyester
ECUV,PQCUV, ECUE:Chip	ECEA,ECST,EEE:Electlytic
ECQMS:Mica	ECQP:Polypropylene

#### Voltage

ECQ Type	ECQG ECQV Type	ECSZ Type	Others		
1H:50V	05:50V	0F:3.15V	0J :6.3V	1V :35V	
2A:100V	1:100V	1A:10V	1A :10V	50,1H:50V	
2E:250V	2:200V	1V:35V	1C :16V	1J :16V	
2H:500V		0J:6.3V	1E,25:25V	2A :100V	

## 16.5.1. Base Unit

### 16.5.1.1. Cabinet and Electrical Parts

Safety	Ref. No.	Part No.	Part Name & Description	Remarks
	1	PNGP1226Z1	PANEL, UPPER	PC-HB
	2	PNKM1255Z2	CABINET BODY	PS-HB
	3	L0AA04A00028	SPEAKER	
	4	PQHR11082Z	GUIDE, SPEAKER	POM-HB
	5	PNKE1130Z2	CASE, CHARGE TERMINAL	PS-HB
	6	PNJT1107Z	CHARGE TERMINAL	
	7	PNJK1145Y	KEYBOARD SWITCH, DIAL	
	8	PNBC1404X4	BUTTON, NAVIGATOR KEY	ABS-HB
	9	PNHR1585Z	GUIDE, BUTTON	PS-HB
	10	PNBC1345Z3	BUTTON, MESSAGE	PMMA-HB
	11	PNJK1146X	KEYBOARD SWITCH, TAM	
	12	PNBC1434Z1	BUTTON, CELL	ABS-HB

Safety	Ref. No.	Part No.	Part Name & Description	Remarks
	13	PNJK1147Z	KEYBOARD SWITCH, HEAD-SET	
	14	PNLA1047Z	ANTENNA, SUB	
	15	PNLA1052Z	ANTENNA, BT	
	16	PNLA1088Z	ANTENNA, SUB	
	17	PQMG10025W	RUBBER PARTS, MIC	
	18	PNHR1584Z	GUIDE, JACK	PS-HB
	19	PQJJ1T039L	JACK, MODULAR	
	20	K2ECYZ000001	JACK, DC	
	21	PNKF1227Z1	CABINET COVER	PS-HB
	22	PNHA1013Z	RUBBER PARTS, FOOT CUSHION	
	23	PNGT6444Z	NAME PLATE	

### 16.5.1.2. Main P.C. Board Parts

#### Note:

(\*1) When replacing IC501, IC502, IC601, IC611 or X501, make the adjustment using PNZZTG7741M. Refer to **How to download the data** (P.62) of Things to Do after Replacing IC or X'tal.

(\*2) When replacing the base unit LCD, See **How to Replace the Base unit LCD** (P.52).

Safety	Ref. No.	Part No.	Part Name & Description	Remarks
	PCB1	PNWP1TG7741H	MAIN P.C.BOARD ASS'Y (RTL) (ICs)	
	IC302	C0DBEYY00102	IC	
	IC501	C1CB00003663	IC (BBIC) (*1)	
	IC502	PNWI2TG7741H	IC (FLASH) (*1)	
	IC601	PNWI3TG7741H	IC (FLASH) (*1)	
	IC611	PNWI1TG7741H	IC (EEPROM) (*1)	
	IC751	C0JBAQ000247	IC (TRANSISTORS)	
	Q141	B1ACGF000008	TRANSISTOR (SI)	
	Q142	B1ABDM000001	TRANSISTOR (SI)	
	Q161	DSC7003S0L	TRANSISTOR (SI)	
	Q301	B1ADGE000012	TRANSISTOR (SI)	
	Q302	B1ADGE000012	TRANSISTOR (SI)	
	Q601	2SC6054JSL	TRANSISTOR (SI)	S
	Q651	PSVTUMG11NTR	TRANSISTOR (SI)	S
	Q652	PSVTUMG11NTR	TRANSISTOR (SI)	S
	Q653	PSVTUMG11NTR	TRANSISTOR (SI)	S
	Q654	2SC6054JSL	TRANSISTOR (SI)	S
	Q655	DRC9113Z0L	TRANSISTOR (SI)	
	Q701	2SA1576S	TRANSISTOR (SI)	S
	Q702	B1GBCFFYY0020	TRANSISTOR (SI)	
	Q731	2SC6054JSL	TRANSISTOR (SI)	S
	Q732	2SC6054JSL	TRANSISTOR (SI)	S
			(DIODES)	
	D101	PQVDM5S	DIODE (SI)	
	D133	DA2J10100L	DIODE (SI)	
	D142	PQVDPTZT2530	DIODE (SI)	S
	D362	B0ECKM000008	DIODE (SI)	
	DA801	B0DDCD000001	DIODE (SI)	
	DA802	B0DDCD000001	DIODE (SI)	
			(COILS)	
	L802	G1C5N6Z00007	COIL	
	L803	G1C5N6Z00007	COIL	
			(RESISTOR ARRAYS)	
	RA451	D1H422220001	RESISTOR ARRAY	
	RA452	D1H427220001	RESISTOR ARRAY	
	RA501	D1H422120001	RESISTOR ARRAY	
	RA651	D1H81024A024	RESISTOR ARRAY	
	RA652	D1H81024A024	RESISTOR ARRAY	
	RA653	D1H81024A024	RESISTOR ARRAY	
	RA721	D1H81024A024	RESISTOR ARRAY	
			(BT UNIT)	
	IC721	PNWP3TG7621H	BT UNIT	
			(VARISTOR)	

Safety	Ref. No.	Part No.	Part Name & Description	Remarks
	SA101	PQVDDSS301L	VARISTOR (SURGE S ABSORBER) (RESISTORS)	
	R101	PQ4R10XJ475	4.7M	S
	R102	PQ4R10XJ475	4.7M	S
	R103	PQ4R10XJ184	180k	S
	R104	PQ4R10XJ184	180k	S
	R105	PQ4R10XJ105	1M	S
	R106	PQ4R10XJ105	1M	S
	R107	D0GA102JA021	1k	
	R108	D0GA102JA021	1k	
	R109	ERJ2GEJ823	82k	S
	R110	ERJ2GEJ823	82k	S
	R111	D0GA392JA015	3.9k	
	R112	D0GA124JA015	120k	
	R121	D0GA102JA021	1k	
	R122	D0GA102JA021	1k	
	R123	D0GA102JA021	1k	
	R125	D0GA271JA015	270	
	R131	PQ4R18XJ106	10M	S
	R133	ERJ3GEYJ154	150k	S
	R141	D0GB104JA057	100k	
	R142	PQ4R18XJ272	2.7k	S
	R144	D0GB103JA057	10k	
	R145	D0GA222JA021	2.2k	
	R151	D0GA104JA021	100k	
	R152	ERJ2GEJ474X	470k	S
	R159	ERJ3GEY0R00	0	S
	R160	ERJ3GEYJ911	910	
	R161	D0GB104JA057	100k	
	R162	D0GB473JA057	47k	
	R163	ERJ14YJ120U	12	
	R164	D0GB272JA057	2.7k	
	R165	ERJ3GEYJ273	27k	S
	R166	ERJ3GEYJ822	8.2k	S
	R167	D0GG270JA007	27	
	R178	D0GA332JA015	3.3k	
	R311	D0GA103JA021	10k	
	R312	D0GA103JA021	10k	
	R321	ERJ2RKF1400	140	
	R322	ERJ2RKF1000	100	
	R371	ERJ14YJ1R0U	1	
	R372	ERJ14YJ1R0U	1	
	R373	D0GA182JA015	1.8k	
	R451	ERJ2GEYJ391	390	S
	R474	D0GA1R0JA014	1	
	R475	D0GA1R0JA014	1	
	R501	D0GA563ZA006	56k	
	R502	D0GA332JA015	3.3k	
	R505	D0GA102JA021	1k	
	R506	D0GA101JA021	100	
	R507	D0GA104JA021	100k	
	R508	ERJ2GEJ100	10	S
	R515	D0GA473JA021	47k	
	R516	D0GA473JA021	47k	
	R517	D0GA473JA021	47k	
	R601	D0GA332JA015	3.3k	
	R602	D0GA561JA021	560	
	R603	D0GA561JA021	560	
	R604	D0GA561JA021	560	
	R605	D0GA222JA021	2.2k	
	R606	D0GA103JA021	10k	
	R607	D0GA103JA021	10k	
	R611	D0GA103JA021	10k	
	R612	D0GA332JA015	3.3k	
	R613	D0GA332JA015	3.3k	
	R651	D0GA681JA021	680	
	R652	D0GA101JA021	100	
	R653	D0GA681JA021	680	
	R654	D0GA101JA021	100	
	R655	D0GA681JA021	680	
	R656	D0GA101JA021	100	
	R657	D0GA681JA021	680	

Safety	Ref. No.	Part No.	Part Name & Description	Remarks
	R658	D0GA122JA015	1.2k	
	R659	D0GA102JA021	1k	
	R660	D0GA102JA021	1k	
	R661	D0GA102JA021	1k	
	R665	D0GA103JA021	10k	
	R668	D0GA561JA021	560	
	R671	D0GA473JA021	47k	
	R672	D0GA473JA021	47k	
	R673	D0GA473JA021	47k	
	R701	ERJ3GEYJ332	3.3k	S
	R702	D0GA103JA021	10k	
	R703	D0GA102JA021	1k	
	R721	ERJ2GEJ474X	470k	S
	R731	D0GA124JA015	120k	
	R732	ERJ2GEJ184	180k	S
	R735	ERJ2RKF4702	47k	
	R736	ERJ2GEJ223	22k	S
	R738	ERJ2RKF3302	33k	
	R751	D0GA102JA021	1k	
	R752	ERJ2GEJ184	180k	S
	R791	ERJ3GEY0R00	0	S
	R801	D0GA180JA015	18	
	R806	D0GA221JA021	220	
	R807	D0GA221JA021	220	
	R891	D0GA221JA021	220	
	R892	D0GA221JA021	220	
			(CAPACITORS)	
	C101	FLK2H681A008	680p	
	C102	FLK2H681A008	680p	
	C103	ECUV1C103KBV	0.01	
	C104	ECUV1C103KBV	0.01	
	C105	FLK2H681A008	680p	
	C106	FLK2H681A008	680p	
	C107	ECUV1C103KBV	0.01	
	C108	ECUV1C103KBV	0.01	
	C109	ECUE1H821KBQ	820p	
	C110	ECUE1H821KBQ	820p	
	C111	ECUE1A333KBQ	0.033	S
	C112	ECUE1H100DCQ	10p	S
	C113	ECUE1A823KBQ	0.082	S
	C123	ECUE1H100DCQ	10p	S
	C124	ECUE1H100DCQ	10p	S
	C125	ECUE1H100DCQ	10p	S
	C132	ECUV1H103KBV	0.01	
	C142	ECUV1H103KBV	0.01	
	C152	ECUE1C103KBQ	0.01	S
	C161	FLK1E1060001	10	
	C168	ECUV1A225KBV	2.2	S
	C171	ECUV1H472KBV	0.0047	
	C172	ECUE1H100DCQ	10p	S
	C173	ECUE1A104KBQ	0.1	
	C174	ECUE1H222KBQ	0.0022	S
	C184	ECUV1C105KBV	1	
	C186	ECUE1H100DCQ	10p	S
	C311	ECUV1C105KBV	1	
	C312	ECUV1C105KBV	1	
	C321	ECUV1A105KBV	1	
	C341	F2A1A3310040	330	
	C342	ECUE1A104KBQ	0.1	
	C343	ECUE1H100DCQ	10p	S
	C351	ECUV1C105KBV	1	
	C451	PQCUV0J106KB	10	S
	C452	ECUE1H100DCQ	10p	S
	C454	ECUE1H100DCQ	10p	S
	C455	ECUE1H100DCQ	10p	S
	C457	ECUE1C333KBQ	0.033	S
	C458	ECUE1C333KBQ	0.033	S
	C459	ECUE1H102KBQ	0.001	S
	C460	ECUE1H100DCQ	10p	S
	C461	ECUE1H100DCQ	10p	S
	C472	ECUE1H100DCQ	10p	S
	C473	ECUE1H100DCQ	10p	S
	C474	ECUE1H222KBQ	0.0022	S

Safety	Ref. No.	Part No.	Part Name & Description	Remarks
	C475	ECUE1H222KBQ	0.0022	S
	C476	ECUE1H151JCQ	150p	
	C477	ECUE1H100DCQ	10p	S
	C478	ECUE1H100DCQ	10p	S
	C479	ECUE1H151JCQ	150p	
	C501	ECUE1A104KBQ	0.1	
	C502	ECUE0J105KBQ	1	
	C503	ECUE1H100DCQ	10p	S
	C504	ECUE1A104KBQ	0.1	
	C505	ECUE1A104KBQ	0.1	
	C506	ECUV1A225KBV	2.2	S
	C507	ECUV1A105KBV	1	
	C508	ECUV1A105KBV	1	
	C509	ECUV0J225KBV	2.2	S
	C511	ECUV1A105KBV	1	
	C513	ECUE1A104KBQ	0.1	
	C516	ECUE1A104KBQ	0.1	
	C517	ECUE1A104KBQ	0.1	
	C518	ECUE1A104KBQ	0.1	
	C519	ECUE1A104KBQ	0.1	
	C601	ECUE1A104KBQ	0.1	
	C603	ECUE1C103KBQ	0.01	S
	C611	ECUE1A104KBQ	0.1	
	C661	ECUE1A104KBQ	0.1	
	C721	ECUE1A104KBQ	0.1	
	C731	ECUE1A104KBQ	0.1	
	C751	ECUE1A104KBQ	0.1	
	C802	F1G1HR8A480	1.8p	
	C803	F1G1HR5A480	1.5p	
	C804	F1G1HR8A480	1.8p	
	C805	F1G1HR3A480	3.3p	
	C806	F1G1HR3A480	3.3p	
	C809	ECUE1H100DCQ	10p	S
	C810	F1G1HR0A480	1p	
	C811	ECUE1H100DCQ	10p	S
	C813	F1G1HR0A480	1p	
	C814	ECUE1H100DCQ	10p	S
	C820	F1G1HR70A480	0.7p	
	C822	ECUE1H100DCQ	10p	S
	C823	ECUE1H101JCQ	100p	
	C825	ECUE1H100DCQ	10p	S
	C826	ECUE1H100DCQ	10p	S
	C837	F1G1HR90A480	0.9p	
	C841	F1G1HR0A480	1p	
	C851	ECUE1H100DCQ	10p	S
	C853	ECUE1H100DCQ	10p	S
	C855	ECUE1H100DCQ	10p	S
	C856	ECUE1H101JCQ	100p	
	C857	ECUE1H100DCQ	10p	S
	C858	ECUE1H101JCQ	100p	
	C863	F1G1H7R0A480	7p	
	C864	F1G1H7R0A480	7p	
			(OTHERS)	
	E1	L5DYBYY00021	LIQUID CRYSTAL DISPLAY (*2)	
	E2	PNHX1406Z	COVER, LCD SHEET	
	E3	PNHR1386Z	GUIDE, LCD	ABS-HB
	P101	D4DAY220A022	THERMISTOR (POSISTOR)	
△	F301	K5H302Y00003	FUSE	
	X501	H0J103500037	CRYSTAL OSCILLATOR (*1)	

### 16.5.1.3. Operational P.C. Board Parts

Safety	Ref. No.	Part No.	Part Name & Description	Remarks
	PCB2	PNWP2TG7741H	OPERATIONAL P.C.BOARD ASS'Y (RTL)	
			(LEDS)	
	LED901	B3AAB0000347	LED	
	LED902	B3AAB0000347	LED	
	LED904	B3AAB0000347	LED	
	LED905	LNJ237W82RA	LED	
	LED906	LNJ237W82RA	LED	

Safety	Ref. No.	Part No.	Part Name & Description	Remarks
	LED907	LNJ237W82RA	LED	
	LED908	LNJ237W82RA	LED	
	LED911	B3AAB0000347	LED	
	LED912	B3AAB0000331	LED	
	LED913	B3AAB0000347	LED	
	LED914	B3AAB0000331	LED	
	LED915	B3AAB0000347	LED	
	LED916	B3AAB0000331	LED	
			(RESISTORS)	
	R901	D0GA271JA015	270	
	R902	D0GA271JA015	270	
	R903	D0GA271JA015	270	
	R904	D0GA271JA015	270	
			(CAPACITORS)	
	C901	ECUV1C105KBV	1	
	C902	F1H1E1050001	1	
	C903	ECUE0J105KBQ	1	
	C910	ECUE1H100DCQ	10p	S
			(OTHER)	
	MIC1	L0CBAY000018	MICROPHONE	

## 16.5.2. Handset

### 16.5.2.1. Cabinet and Electrical Parts

Safety	Ref. No.	Part No.	Part Name & Description	Remarks
	101	PNGP1228Z2	PANEL, LCD	PMMA-HB
	102	PNYE1066Z	TAPE, DOUBLE SIDED	
	103	PNKML257Y2	CABINET BODY	ABS-HB
	104	PNGT6432Y	NAME PLATE	
	105	LOAD01A00026	RECEIVER	
	106	PNYE1065Y	SPACER, CUSHION LCD	
	107	PNBC1354ZA	BUTTON, NAVIGATOR KEY	ABS-HB
	108	PNJK1149Y	KEYBOARD SWITCH	
	109	PNJT1027Z	CHARGE TERMINAL (L)	
	110	PNJT1026Z	CHARGE TERMINAL (R)	
	111	PNJK1150Z	RUBBER PARTS, SIDE SWITCH	
	112	PQHR11315Z	GUIDE, SPEAKER	ABS-HB
	113	LOAA02A00096	SPEAKER	
	114	PQHS10784Y	SPACER, SPEAKER NET	
	115	PQJC10056W	BATTERY TERMINAL	
	116	PNKE1131Z1	COVER, EP CAP	
	117	PNKF1229Z1	CABINET COVER	ABS-HB
	118	PNHR1588Z	OPTIC CONDUCTIVE PARTS, LED LENS	PS-HB
	119	PNQT2006Z	LABEL, ATTENTION	
	120	PNQT2335Z	LABEL, BATTERY	
	121	PNHS1079Z	SPACER, BATTERY	
	122	PNKK1066Z1	LID, BATTERY	ABS-HB
	123	PNYNTGA470BR	LID, BATTERY ASS'Y	ABS-HB

### 16.5.2.2. Main P.C. Board Parts

#### Note:

(\*1) Reconfirm the model No. written on the handset's name plate when replacing PCB100. Because the model No. of the optional handset may differ from the included handset.

(\*2) When replacing IC3 or X1, make the adjustment using PNZZTG7741M. Refer to **Handset** (P.63) of Things to Do after Replacing IC or X'tal.

(\*3) When replacing the handset LCD, See **How to Replace the Handset LCD** (P.54).

Safety	Ref. No.	Part No.	Part Name & Description	Remarks
	PCB100	PNWP1TGA470R	MAIN P.C.BOARD ASS'Y (RTL) (*1)	
			(ICs)	
	IC1	C2HBCY000081	IC	
	IC3	PNWITGA470BR	IC(EEPROM) (*2)	

Safety	Ref. No.	Part No.	Part Name & Description	Remarks
	IC4	C0DBZYY00357	IC (TRANSISTORS)	
	Q2	B1ADCF000040	TRANSISTOR(SI)	
	Q3	B1ABGE000011	TRANSISTOR(SI)	
	Q4	B1ADCF000040	TRANSISTOR(SI)	
	Q5	DRC9113Z0L	TRANSISTOR(SI)	
	Q6	DRC9113Z0L	TRANSISTOR(SI)	
	Q9	2SC6054JSL	TRANSISTOR(SI) (DIODES)	S
	D13	B0BC4R3A0006	DIODE(SI)	
	D14	B0BC4R3A0006	DIODE(SI)	
	D21	B0BC4R3A0006	DIODE(SI)	
	D22	B0BC4R3A0006	DIODE(SI)	
	DA801	B0DDCD000001	DIODE(SI) (LEDS)	
	LED1	B3ACB0000190	LED	
	LED2	B3ACB0000190	LED	
	LED3	B3ACB0000190	LED	
	LED4	B3ACB0000190	LED	
	LED5	B3ACB0000190	LED	
	LED6	B3ACB0000190	LED	
	LED11	B3ACB0000190	LED	
	LED12	B3ACB0000190	LED (COILS)	
	C812	PQLQR4C8N2J	COIL	S
	L4	G1CR18J00004	COIL (RESISTOR ARRAYS)	
	RA2	D1H83314A013	RESISTOR ARRAY	S
	RA3	D1H83314A013	RESISTOR ARRAY	S
	RA4	D1H433220001	RESISTOR ARRAY	
	RA5	EXB28V332JX	RESISTOR ARRAY (IC FILTERS)	
	L1	J0JCC0000286	IC FILTER	
	L3	J0JDC0000045	IC FILTER	
	L7	J0JCC0000276	IC FILTER	
	L10	J0JCC0000286	IC FILTER	
	L75	J0JCC0000286	IC FILTER (SWITCHES)	
	VOL_DW	K0H1BB000094	TACTILE SWITCH	
	VOL_UP	K0H1BB000094	TACTILE SWITCH (RESISTORS)	
	R2	ERJ2GEJ303	30k	
	R3	D0GA152JA021	1.5k	
	R4	D0GA473JA021	47k	
	R6	D0GA103JA021	10k	
	R7	D0GA104JA021	100k	
	R8	PQ4R18XJ3R3	3.3	S
	R9	ERJ2GEJ303	30k	
	R21	D0GA104JA021	100k	
	R22	D0GA332JA015	3.3k	
	R23	ERJ2GEYJ391	390	S
	R24	ERJ2GEJ100	10	S
	R25	D0GA222JA021	2.2k	
	R26	D0GA332JA015	3.3k	
	R27	D0GA222JA021	2.2k	
	R28	D0GA222JA021	2.2k	
	R31	ERJ2RKF1003	100k	
	R32	D0GA104JA021	100k	
	R33	ERJ2RKF1003	100k	
	R34	ERJ2GEYJ391	390	S
	R45	ERJ6RSJR10V	0.1	
	R50	D0GA151JA021	150	
	R51	D0GA151JA021	150	
	R60	D0GA222JA021	2.2k	
	R66	D0GA103JA021	10k	
	R67	D0GA103JA021	10k	
	R68	D0GA103JA021	10k	
	R69	D0GA103JA021	10k	
	R70	D0GA470JA021	47	
	R73	D0GA330JA015	33	
	R74	D0GA330JA015	33	
	R80	D0GA101JA021	100	
	R806	ERJ2GEJ471	470	S

Safety	Ref. No.	Part No.	Part Name & Description	Remarks
	R807	ERJ2GEJ471	470	S
	L8	ERJ2GEJ100	10	S
	L9	ERJ2GE0R00	0	S
			(CAPACITORS)	
	C1	EEE0JA221WP	220	
	C2	EEE0JA221WP	220	
	C3	EEE0JA221WP	220	
	C4	ECUE1H390JQC	39p	
	C5	ECUE1A104KBQ	0.1	
	C6	ECUE1A104KBQ	0.1	
	C9	ECUE1H390JQC	39p	
	C10	ECUE1H390JQC	39p	
	C11	ECUE1A104KBQ	0.1	
	C12	PQCV0J106KB	10	S
	C13	ECUE1A104KBQ	0.1	
	C14	ECUV1C393KBV	0.039	
	C15	ECUE1H390JQC	39p	
	C16	F1J0J2260002	22	
	C17	ECUE1H100DCQ	10p	S
	C18	ECUE1H100DCQ	10p	S
	C20	ECJ1VB0G106M	10	S
	C21	ECUE0J105KBQ	1	
	C22	ECUE1A104KBQ	0.1	
	C23	ECUE1A104KBQ	0.1	
	C24	ECUE0J105KBQ	1	
	C25	ECUV1A225KBV	2.2	S
	C26	ECJ1VB0G106M	10	S
	C27	ECUE1H102KBQ	0.001	S
	C29	ECUV1A105KBV	1	
	C30	ECUV1A105KBV	1	
	C31	ECJ1VB0G106M	10	S
	C32	ECUE0J105KBQ	1	
	C33	ECUE1A104KBQ	0.1	
	C34	ECUE1H390JQC	39p	
	C36	ECUE1A104KBQ	0.1	
	C37	ECJ1VB0G106M	10	S
	C39	ECUE1H102KBQ	0.001	S
	C40	ECUE1A104KBQ	0.1	
	C41	ECUE1A104KBQ	0.1	
	C42	ECUE1H102KBQ	0.001	S
	C43	ECUE1A104KBQ	0.1	
	C44	ECUE0J105KBQ	1	
	C45	ECUE1A104KBQ	0.1	
	C46	ECUE1H100DCQ	10p	S
	C51	ECJ1VB0G106M	10	S
	C52	ECUE1H100DCQ	10p	S
	C53	ECUE1H120JQC	12p	S
	C56	ECUE0J105KBQ	1	
	C57	ECUE0J105KBQ	1	
	C58	ECUE0J105KBQ	1	
	C68	ECUE0J105KBQ	1	
	C69	ECUE1A104KBQ	0.1	
	C72	ECUE1H100DCQ	10p	S
	C73	ECUE1H100DCQ	10p	S
	C76	ECUE1H100DCQ	10p	S
	C77	ECUE1H100DCQ	10p	S
	C79	ECUE1H101JQC	100p	
	C80	ECUV1C393KBV	0.039	
	C81	ECUE1H101JQC	100p	
	C82	ECUE1H471KBQ	470p	S
	C83	ECUE1H100DCQ	10p	S
	C84	ECUE1H102KBQ	0.001	S
	C87	ECUE1H102KBQ	0.001	S
	C88	ECUE1H100DCQ	10p	S
	C89	ECUE1H100DCQ	10p	S
	C90	ECUE1A104KBQ	0.1	
	C91	ECUV1C105KBV	1	
	C92	ECUE0J105KBQ	1	
	C93	ECUV1C105KBV	1	
	C96	ECUE1H100DCQ	10p	S
	C97	ECUE1H100DCQ	10p	S
	C801	ECUV1H100DCV	10p	
	C802	F1G1H2R0A480	2p	

Safety No.	Ref. No.	Part No.	Part Name & Description	Remarks
	C803	F1G1H1R3A480	1.3p	
	C804	F1G1H1R8A480	1.8p	
	C805	F1G1H2R4A480	2.4p	
	C806	F1G1H2R4A480	2.4p	
	C810	F1G1H2R5A480	2.5p	
	C811	ECUE1H101JQC	100p	S
	C813	F1G1H1R6A480	1.6p	
	C820	F1G1H1R8A480	1.8p	
	C822	ECUE1H100DCQ	10p	S
	C825	ECUE1H100DCQ	10p	S
	C826	ECUE1H100DCQ	10p	S
	C863	F1G1H1R8A480	1.8p	
	C897	F1G1H240A557	24p	
	L809	F1G1H1R0A480	1p	
			(OTHERS)	
	MIC100	L0CBAY000053	MICROPHONE	
	E101	L5DYBYY00043	LIQUID CRYSTAL DISPLAY (*3)	
	E102	PNHX1569Z	COVER, DIFFUSION SHEET	
	E103	PNHX1518Z	COVER, LCD SHEET	
	E104	PNHR1587Z	TRANSPARENT PLATE, LCD	PMMA-HB
	E105	PNHR1586Z	GUIDE, LCD	ABS-HB
	E106	PQHG10729Z	RUBBER PARTS, RECEIVER	
	E107	PNVE1002Z	BATTERY TERMINAL	ABS-HB
	CN4	K2HD103D0001	JACK	
	F1	K5H252Y00002	FUSE	
	X1	H0J138500003	CRYSTAL OSCILLATOR (*2)	S

### 16.5.2.3. LED Board Parts

Safety No.	Ref. No.	Part No.	Part Name & Description	Remarks
			(LED)	
	WLLED	B3AFB0000370	LED	

### 16.5.3. Charger Unit

#### 16.5.3.1. Cabinet and Electrical Parts

Safety No.	Ref. No.	Part No.	Part Name & Description	Remarks
	200	PNLC1029ZS	CHARGER UNIT ASS'Y without NAME PLATE (RTL)	
	200-1	PNKM1258Y2	CABINET BODY	PS-HB
	200-2	PNJT1105Z	CHARGE TERMINAL	
	200-3	PNKF1150Z1	CABINET COVER	PS-HB
	200-4	PQHA10023Z	RUBBER PARTS, FOOT CUSHION	
	201	PNGT6446Z	NAME PLATE	

#### 16.5.3.2. Main P.C. Board Parts

Safety No.	Ref. No.	Part No.	Part Name & Description	Remarks
	PCB200	PNWPTGA470CH	MAIN P.C.BOARD ASS'Y (RTL)	
			(DIODE)	
	D1	B0ECKM000008	DIODE(SI)	
			(JACK)	
	J1	K2ECYB000001	JACK	
			(RESISTORS)	
	R1	ERJ14YJ1R0U	1	
	R2	ERJ14YJ1R0U	1	
			(FUSE)	
	F1	K5H302Y00003	FUSE	

#### 16.5.4. Accessories and Packing Materials

##### Note:

(\*1) You can download and refer to the Operating Instructions (Instruction book) on TSN Server.

#### 16.5.4.1. KX-TG7741S

Safety No.	Ref. No.	Part No.	Part Name & Description	Remarks
	A1	PNLV226Z	AC ADAPTOR	
	A2	PQJA10075Z	CORD, TELEPHONE	
	A3	PNQX5106Z	INSTRUCTION BOOK (*1)	
	A4	PNQW3019Z	LEAFLET, QUICK GUIDE	
	A5	PNKE1132Z1	HANGER, BELT CLIP	ABS-HB
	A6	PNKL1001Y1	STAND, WALL MOUNT	ABS-HB
	P1	PNPK3484002Z	GIFT BOX	
	P2	PNPD1644Z	CUSHION	

#### 16.5.4.2. KX-TG7742S

Safety No.	Ref. No.	Part No.	Part Name & Description	Remarks
	A101	PNLV226Z	AC ADAPTOR	
	A102	PQJA10075Z	CORD, TELEPHONE	
	A103	PNQX5106Z	INSTRUCTION BOOK (*1)	
	A104	PNQW3019Z	LEAFLET, QUICK GUIDE	
	A105	PNKE1132Z1	HANGER, BELT CLIP	ABS-HB
	A106	PNKL1001Y1	STAND, WALL MOUNT	ABS-HB
	P101	PNPK3485002Z	GIFT BOX	
	P102	PNPD1191Z	CUSHION, AC ADAPTOR	
	P103	PNPD1589Z	CUSHION	

#### 16.5.4.3. KX-TG7743S

Safety No.	Ref. No.	Part No.	Part Name & Description	Remarks
	A201	PNLV226Z	AC ADAPTOR	
	A202	PQJA10075Z	CORD, TELEPHONE	
	A203	PNQX5106Z	INSTRUCTION BOOK (*1)	
	A204	PNQW3019Z	LEAFLET, QUICK GUIDE	
	A205	PNKE1132Z1	HANGER, BELT CLIP	ABS-HB
	A206	PNKL1001Y1	STAND, WALL MOUNT	ABS-HB
	P201	PNPK3486002Z	GIFT BOX	
	P202	PNPD1590Z	CUSHION	
	P203	PNPD1650Z	CUSHION (TG4743 with carton)	

#### 16.5.4.4. KX-TGA470S

Safety No.	Ref. No.	Part No.	Part Name & Description	Remarks
	A301	PNLV226Z	AC ADAPTOR	
	A302	PNQX5093Z	INSTRUCTION BOOK (*1)	
	A303	PNKE1132Z1	HANGER, BELT CLIP	ABS-HB
	P301	PNPK3490001Z	GIFT BOX	
	P302	PNPD1648Z	CUSHION	

#### 16.5.5. Screws

Safety No.	Ref. No.	Part No.	Part Name & Description	Remarks
	A	XTB26+8GFJ	TAPPING SCREW	
	B	XTB2+8GFJ	TAPPING SCREW	

#### 16.5.6. Fixtures and Tools

##### Note:

(\*1) See **Equipment Required** (P.55), and **The Setting Method of JIG** (P.55)

(\*2) When replacing the Handset LCD, See **How to Replace the Handset LCD** (P.54)

Safety No.	Ref. No.	Part No.	Part Name & Description	Remarks
		PQZZ1CD300E	JIG CABLE (*1)	

KX-TG7741S/KX-TG7742S/KX-TG7743S/KX-TGA470S

Safety	Ref. No.	Part No.	Part Name & Description	Remarks
		PNZZTG7741M	BATCH FILE CD-ROM (*1)	
		PQZZ430PIR	TIP OF SOLDERING IRON (*2)	
		PQZZ430PRB	RUBBER OF SOLDERING IRON (*2)	

T./N  
KXTG7741S  
KXTG7742S  
KXTG7743S  
KXTGA470S