

Service Manual

Telephone Equipment

Caller ID Compatible

DECT
6.0



KX-TGA641M/T
(Handset)

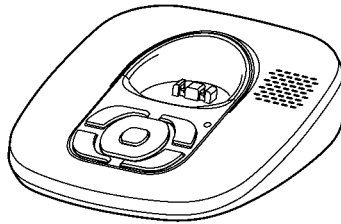

KX-TG6431M/T
(Base Unit)

Model No. **KX-TG6431M**
KX-TG6431T
KX-TGA641M
KX-TGA641T

Expandable Digital Cordless Answering System

M: Metallic Gray Version
T: Black Metallic Version
(for U.S.A.)

Configuration for each model

Model No	Base Unit	Handset	Charger Unit	Expandable
KX-TG6431	1 (TG6431)	1 (TGA641)		Up to 6

* For the bundle model (KX-TG6432/6433/6434), refer to KX-TG6432/6433/6434 service manual.

 **WARNING**

This service information is designed for experienced repair technicians only and is not designed for use by the general public. It does not contain warnings or cautions to advise non-technical individuals of potential dangers in attempting to service a product. Products powered by electricity should be serviced or repaired only by experienced professional technicians. Any attempt to service or repair the product or products dealt with in this service information by anyone else could result in serious injury or death.

IMPORTANT SAFETY NOTICE

There are special components used in this equipment which are important for safety. These parts are marked by  in the Schematic Diagrams, Circuit Board Diagrams, Exploded Views and Replacement Parts List. It is essential that these critical parts should be replaced with manufacturer's specified parts to prevent shock, fire or other hazards. Do not modify the original design without permission of manufacturer.

IMPORTANT INFORMATION ABOUT LEAD FREE, (PbF), SOLDERING

If lead free solder was used in the manufacture of this product, the printed circuit boards will be marked PbF. Standard leaded, (Pb), solder can be used as usual on boards without the PbF mark. When this mark does appear, please read and follow the special instructions described in this manual on the use of PbF and how it might be permissible to use Pb solder during service and repair work.

- When you note the serial number, write down all 11 digits. The serial number may be found on the bottom of the unit.
- The illustrations in this Service Manual may vary slightly from the actual product.

Note for TABLE OF CONTENTS:

Because sections 4, 5 and 6 of this manual are extracts from the operating instructions for this model, they are subject to change without notice. You can download and refer to the original operating instructions on TSN Server for further information.

TABLE OF CONTENTS

	PAGE
1 Safety Precautions -----	4
1.1. For Service Technicians -----	4
2 Warning -----	4
2.1. Battery Caution-----	4
3 Specifications -----	5
4 Location of Controls and Components -----	6
4.1. Controls -----	6
4.2. Display -----	7
5 Installation Instructions -----	8
5.1. Connections-----	8
5.2. Battery-----	8
6 Operating Instructions -----	10
6.1. Programmable Settings -----	10
6.2. Error Messages -----	14
6.3. Troubleshooting -----	15
7 Schematic Diagram -----	19
7.1. For Schematic Diagram-----	19
7.2. Schematic Diagram (Base Unit_Main) -----	20
7.3. Schematic Diagram (Base Unit_RF Part) -----	22
7.4. Schematic Diagram (Base Unit_Operation) -----	24
7.5. Schematic Diagram (Handset_Main)-----	26
7.6. Schematic Diagram (Handset_RF Part) -----	28
8 Exploded View and Replacement Parts List -----	30

1 Safety Precautions

1.1. For Service Technicians

- **Repair service shall be provided in accordance with repair technology information such as service manual so as to prevent fires, injury or electric shock, which can be caused by improper repair work.**

1. When repair services are provided, neither the products nor their parts or members shall be remodeled.
2. If a lead wire assembly is supplied as a repair part, the lead wire assembly shall be replaced.
3. FASTON terminals shall be plugged straight in and unplugged straight out.

- **ICs and LSIs are vulnerable to static electricity.**

When repairing, the following precautions will help prevent recurring malfunctions.

1. Cover plastic parts boxes with aluminum foil.
2. Ground the soldering irons.
3. Use a conductive mat on worktable.
4. Do not grasp IC or LSI pins with bare fingers.

2 Warning

2.1. Battery Caution

Risk of explosion if battery is replaced by an incorrect type. Dispose of used batteries according to the instructions.

3 Specifications

- **Standard:**
DECT 6.0 (Digital Enhanced Cordless Telecommunications 6.0)
- **Number of channels:**
60 Duplex Channels
- **Frequency range:**
1.92 GHz to 1.93 GHz
- **Duplex procedure:**
TDMA (Time Division Multiple Access)
- **Channel spacing:**
1,728 kHz
- **Bit rate:**
1,152 kbit/s
- **Modulation:**
GFSK (Gaussian Frequency Shift Keying)
- **RF transmission power:**
115 mW (Max.)
- **Voice coding:**
ADPCM 32 kbit/s

	Base Unit	Handset
Power source	AC Adaptor (PQLV219Z, 120 V AC, 60 Hz)	Rechargeable Ni-MH battery AAA (R03) size (1.2 V 630 mAh)
Receiving Method	Super Heterodyne	Super Heterodyne
Oscillation Method	PLL synthesizer	PLL synthesizer
Detecting Method	Quadrature Discriminator	Quadrature Discriminator
Tolerance of OSC Frequency	13.824 MHz \pm 100 Hz	13.824 MHz \pm 100 Hz
Modulation Method	Frequency Modulation	Frequency Modulation
ID Code	40 bit	40 bit
Ringer Equivalence No. (REN)	0.1B	—
Dialing Mode	—	Tone (DTMF)/Pulse
Redial	—	Up to 48 digits
Speed Dialer	—	Up to 32 digits (Phonebook)
Power Consumption	Standby: Approx. 1.1 W Maximum: Approx. 4.4 W	11 days at Standby, 5 hours at Talk
Operating Conditions	0 °C - 40 °C (32 °F - 104 °F) 20 % - 80 % relative air humidity (dry)	0 °C - 40 °C (32 °F - 104 °F) 20 % - 80 % relative air humidity (dry)
Dimensions (H x W x D)	Approx. 54 mm x 126 mm x 126 mm	Approx. 158 mm x 48 mm x 32 mm
Mass (Weight)	Approx. 160 g	Approx. 130 g

Note:

- Design and specifications are subject to change without notice.

Note for Service:

- **Operation range:** Up to 300 m outdoors, Up to 50 m indoors, depending on the condition.
- **Analog telephone connection:** Telephone Line
- **Optional headset:** KX-TCA60, KX-TCA86, KX-TCA92, KX-TCA93, KX-TCA94

4 Location of Controls and Components

4.1. Controls

4.1.2. Handset

4.1.1. Base Unit

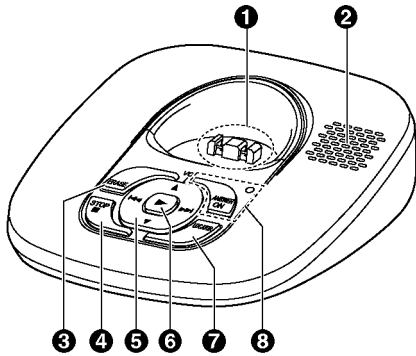

- 1 Charge contacts
- 2 Speaker
- 3 [ERASE]
- 4 [■] (STOP)
- 5 [▲]/[▼] (VOL.: Volume up/down)
[◀◀]/[▶▶] (Repeat/Skip)
- 6 [▶] (Play)
Message indicator
- 7 [LOCATOR]
- 8 [ANSWER ON]
ANSWER ON indicator

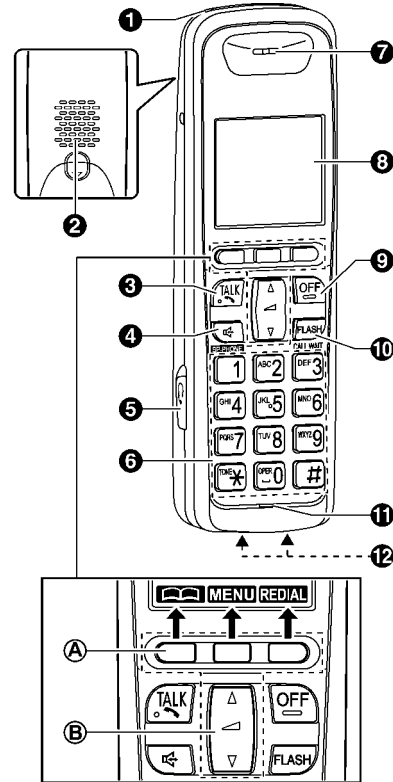

- 1 Charge indicator
Ringer indicator
Message indicator
- 2 Speaker
- 3 [☎] (TALK)
- 4 [☎] (SP-PHONE: Speakerphone)
- 5 Headset jack
- 6 Dial keypad ([*]: TONE)
- 7 Receiver
- 8 Display
- 9 [OFF]
- 10 [FLASH] [CALL WAIT]
- 11 Microphone
- 12 Charge contacts

Control type

A Soft keys











The handset features 3 soft keys. By pressing a soft key, you can select the feature shown directly above it on the display.

B Navigator key/ ▲ (Volume) key
By pressing this key ([▲] or [▼]) repeatedly, you can:

- scroll through (up or down) various lists or items
- adjust the receiver or speaker volume (up or down) while talking
- move the cursor (left or right) to edit number or name

4.2. Display

Handset display items

Item	Meaning
	Within range of a base unit
	Out of range of a base unit
	<p>The line is in use.</p> <ul style="list-style-type: none"> • When flashing: <ul style="list-style-type: none"> – The call is put on hold. – The answering system is answering a call. • When flashing rapidly: <ul style="list-style-type: none"> – An incoming call is now being received.
	Speaker is on.
	Ringer volume is off.
	Silent mode is on.
	Clarity booster is on.
	Alarm is on.
	Handset number
	Battery level
	Blocked call

5 Installation Instructions

5.1. Connections

- Use only the supplied Panasonic AC adaptor PQLV219Z.

Base unit

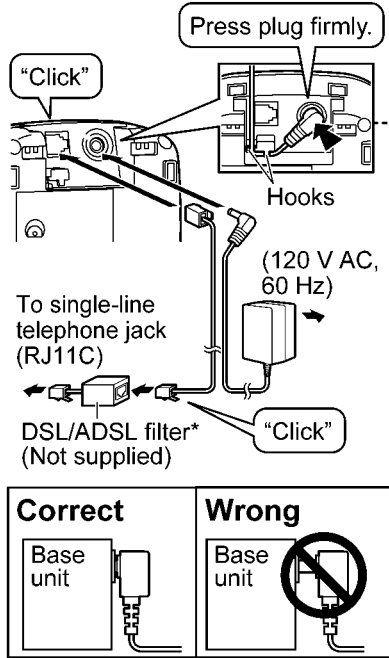

*For DSL/ADSL service users

Note

- The AC adaptor must remain connected at all times. (It is normal for the adaptor to feel warm during use.)
- The AC adaptor should be connected to a vertically oriented or floor-mounted AC outlet. Do not connect the AC adaptor to a ceiling-mounted AC outlet, as the weight of the adaptor may cause it to become disconnected.

During a power failure

The unit will not work during a power failure. We recommend connecting a corded-type telephone (without AC adaptor) to the same telephone line or to the same telephone line jack using a Panasonic T-adaptor. Emergency power can be supplied to the unit by connecting a Panasonic battery back-up power supply.

5.2. Battery

5.2.1. Battery Installation

- USE ONLY Ni-MH batteries AAA (R03) size.
- Do NOT use Alkaline/Manganese/Ni-Cd batteries.
- Confirm correct polarities (\oplus , \ominus).

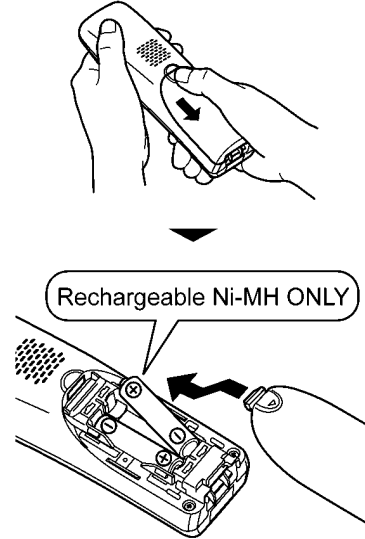

Note

- Use the supplied rechargeable batteries. For replacement, we recommend using the Panasonic rechargeable batteries HHR-4DPA.
- Wipe the battery ends (\oplus , \ominus) with a dry cloth.
- Avoid touching the battery ends (\oplus , \ominus) or the unit contacts.

Attention:



A nickel metal hydride battery that is recyclable powers the product you have purchased. Please call 1-800-8-BATTERY (1-800-822-8837) for information on how to recycle this battery.

5.2.2. Battery Charge

Charge for about 7 hours.

- When the batteries are fully charged, the charge indicator goes off.

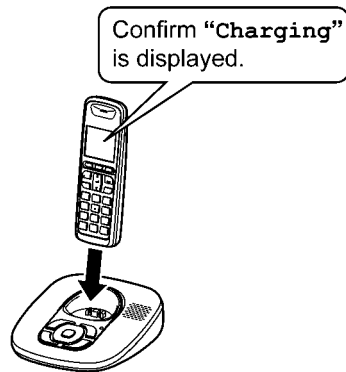

Note:

- It is normal for the handset to feel warm during charging.
- Clean the charge contacts of the handset, base unit, and charger with a soft and dry cloth. Clean if the unit is exposed to grease, dust, or high humidity.

Note for service:

The battery strength may not be indicated correctly if the battery is disconnected and connected again, even after it is fully charged. In that case, by recharging the battery as mentioned above, you will get a correct indication of the battery strength.

5.2.3. Battery Level

Icon	Battery level
	High
	Medium
	Low
	Needs charging.
	Empty

Note:

- The batteries need to be charged if:
 - the handset alerts you with a voice announcement (**talking battery alert**) after you finish talking or listening to a message.
 - the handset beeps while you are engaged in a call or operating the answering system remotely.

5.2.4. Panasonic Ni-MH Battery Performance (supplied batteries)

Operation	Operating time
In continuous use	5 hours max.* ¹
Not in use (standby)	11 days max.

*1 When the clarity booster feature is turned on: 3 hours max.

Note:

- Actual battery performance depends on a combination of how often the handset is in use and how often it is not in use (standby).
- Even after the handset is fully charged, the handset can be left on the base unit without any ill effect on the batteries.
- The battery level may not be displayed correctly after you replace the batteries. In this case, place the handset on the base unit and let it charge for at least 7 hours.

6 Operating Instructions

6.1. Programmable Settings

You can customize the unit by programming the following features using the handset.



To access the features, there are 2 methods:

- scrolling through the display menus
- using the direct commands
- Direct command is the main method used in these operating instructions.

6.1.1. Programming by Scrolling through the Display Menus

- 1 **[MENU]**
- 2 Press **[▼]** or **[▲]** to select the desired main menu. → **[SELECT]**
- 3 Press **[▼]** or **[▲]** to select the desired item in sub-menu 1. → **[SELECT]**
 - In some cases, you may need to select from sub-menu 2. → **[SELECT]**
- 4 Press **[▼]** or **[▲]** to select the desired setting. → **[SAVE]**
 - This step may vary depending on the feature being programmed.
 - To exit the operation, press **[OFF]**.

Main menu	Sub-menu 1	Sub-menu 2	
Caller list →)	–	–	
Answering device ☎	Play new msg.	–	
	Play all msg.	–	
	Erase all msg. ^{*1}	–	
	Greeting	Record greeting ^{*1}	
		Check greeting	
		Pre-recorded ^{*1}	
	Settings	Ring count ^{*1}	
		Recording time ^{*1}	
		Remote code ^{*1}	
	Answer on ^{*1}	–	
Answer off ^{*1}	–		
V.M. access #	–	–	
Intercom •))	–	–	

Main menu	Sub-menu 1	Sub-menu 2
Initial setting 	Ringer setting	Ringer volume
		Ringer tone
		Silent mode – On / Off – Start / End
	Set date / time	Date and time ^{*1}
		Alarm
		Time adjust ^{*1}
	Talking CallerID	Handset
		Base unit ^{*1}
	Voice Mail	Store V.M. no. ^{*1}
		VM tone detect ^{*1}
	Call block ^{*1}	–
	Message alert	–
	Display setting	LCD contrast
	Key tone	–
	Auto talk	–
	Caller ID edit ^{*1}	–
	Set tel line	Set dial mode ^{*1}
		Set flash time ^{*1}
		Set line mode ^{*1}
	Registration	Register handset
Deregistration		
Change language	Display	
	Voice prompt ^{*1}	
Customer support 	–	–

*1 If you program these settings using one of the handsets, you do not need to program the same item using another handset.

6.1.2. Programming using the Direct Commands

- 1 **[MENU]** → **[#]**
- 2 Enter the desired feature code.
- 3 Enter the desired setting code. → **[SAVE]**
 - This step may vary depending on the feature being programmed.
 - To exit the operation, press **[OFF]**.

Note:

- In the following table, < > indicates the default settings.

Feature	Feature code	Setting code	System setting ^{*1}
Alarm	[7][2][0]	[1]: Once [2]: Daily [0]: <Off>	–
Answer off	[3][2][8]	–	●
Answer on	[3][2][7]	–	●
Auto talk ^{*2}	[2][0][0]	[1]: On [0]: <Off>	–
Block w/o num. (Block calls without phone number)	[2][4][0]	[1]: On [0]: <Off>	●
Call block	[2][1][7]	–	●
Caller ID edit (Caller ID number auto edit)	[2][1][4]	[1]: <On> [0]: Off	●
Caller list	[2][1][3]	–	–
Check greeting	[3][0][3]	–	–
Customer support ^{*3}	[6][8][0]	–	–
Date and time	[1][0][1]	–	●
Deregistration	[1][3][1]	–	–
Display (Change language)	[1][1][0]	[1]: <English> [2]: Español	–
Erase all msg. (msg.: messages)	[3][2][5]	–	●
Intercom	[2][7][4]	–	–
Key tone ^{*4}	[1][6][5]	[1]: <On> [0]: Off	–
LCD contrast (Display contrast)	[1][4][5]	[1]–[6]: Level 1–6 <3>	–
Message alert	[3][4][0]	[1]: <On> [0]: Off	–
Play all msg. (msg.: messages)	[3][2][4]	–	–
Play new msg. (msg.: messages)	[3][2][3]	–	–
Pre-recorded (Reset to pre-recorded greeting)	[3][0][4]	–	●
Record greeting	[3][0][2]	–	●
Recording time	[3][0][5]	[1]: 1min [2]: 2min [3]: <3min> [0]: Greeting only	●
Register handset	[1][3][0]	–	–
Remote code	[3][0][6]	<111>	●
Ring count	[2][1][1]	[2]–[7]: 2–7 rings <4> [0]: Toll saver	●
Ringer tone ^{*5, *6} (Handset)	[1][6][1]	[1]–[3]: Tone <1>–3 [4]–[7]: Melody 1–4	–
Ringer volume ^{*7} (Handset)	[1][6][0]	[1]: Low [2]: Medium [3]: <High> [0]: Off	–

Feature	Feature code	Setting code	System setting ^{*1}
Set dial mode	[1][2][0]	[1]: Pulse [2]: <Tone>	●
Set flash time ^{*8}	[1][2][1]	[0]: 900ms [1]: <700ms> [2]: 600ms [3]: 400ms [4]: 300ms [5]: 250ms [*]: 200ms [†]: 160ms [6]: 110ms [7]: 100ms [8]: 90ms [9]: 80ms	●
Set line mode ^{*9}	[1][2][2]	[1]: A [2]: 	●
Silent mode (On/Off)	[2][3][8]	[1]: On [0]: <Off>	—
Silent mode (Start/End)	[2][3][7]	<11:00 PM/06:00 AM>	—
Store V.M. no. (V.M.: Voice mail)	[3][3][1]	—	●
Talking CallerID (Handset)	[1][6][2]	[1]: <On> [0]: Off	—
Talking CallerID (Base unit)	[*][1][6] [2]	[1]: On [0]: <Off>	●
Time adjust ^{*10} (Caller ID subscribers only)	[2][2][6]	[1]: <Caller ID auto> [0]: Manual	●
V.M. access (V.M.: Voice mail)	[3][3][0]	—	—
VM tone detect (VM: Voice mail)	[3][3][2]	[1]: <On> [0]: Off	●
Voice prompt (Change language)	[1][1][2]	[1]: <English> [2]: Español	●

*1 If "System setting" column is checked, you do not need to program the same item using another handset.

*2 If you subscribe to a Caller ID service and want to view the caller's information after lifting up the handset to answer a call, turn off this feature.

*3 The handset can display the Internet address where you can download the operating instructions or get further information for this product, using your computer.

*4 Turn this feature off if you prefer not to hear key tones while you are dialing or pressing any keys, including confirmation tones and error tones.

*5 If you subscribe to a distinctive ring service (such as IDENT-A-RING), select a tone (tone 1 to 3). If you select a melody, you cannot distinguish lines by their ringers.

*6 If you select one of the melody ringer tones, the ringer tone continues to play for several seconds even if the caller has already hung up. You may either hear a dial tone or no one on the line when you answer the call.

*7 When the ringer volume is turned off, \mathcal{R} is displayed and the handset does not ring for outside calls.

However even when the ringer volume is set to off, the handset rings at the low level for alarm, intercom calls, and paging.

*8 The flash time depends on your telephone exchange or host PBX. Contact your PBX supplier if necessary. The setting should stay at "700ms" unless pressing **[FLASH]** fails to pick up the waiting call.

*9 Generally, the line mode setting should not be adjusted. If **IN USE** is not displayed when another phone connected to the same line is in use, you need to change the line mode to "A".

*10 This feature allows the unit to automatically adjust the date and time setting when caller information is received. To use this feature, set the date and time first.

6.2. Error Messages

If the unit detects a problem, one of the following messages is shown on the display.

Display message	Cause/solution
Busy or System busy. Try again later.	<ul style="list-style-type: none"> ● The called unit is in use. ● Other units are in use and the system is busy. Try again later. ● The handset you are using is too far from the base unit. Move closer and try again. ● The handset's registration may have been canceled. Re-register the handset.
Check tel line	<ul style="list-style-type: none"> ● The supplied telephone line cord has not been connected yet or not connected properly. Check the connections.
Use rechargeable battery.	<ul style="list-style-type: none"> ● A wrong type of battery such as Alkaline or Manganese was inserted. Use only the rechargeable Ni-MH batteries.
Error!!	<ul style="list-style-type: none"> ● The handset's registration has failed. Move the handset and base unit away from all electrical appliances and try again.
Invalid	<ul style="list-style-type: none"> ● There is no handset registered to the base unit matching the handset number you entered. ● The handset is not registered to the base unit. Register the handset.
No link. Reconnect base AC adaptor.	<ul style="list-style-type: none"> ● The handset has lost communication with the base unit. Move closer to the base unit and try again. ● Unplug the base unit's AC adaptor to reset the unit. Reconnect the adaptor and try again. ● The handset's registration may have been canceled. Re-register the handset.
Requires subscription to Caller ID.	<ul style="list-style-type: none"> ● You must subscribe to a Caller ID service. Once you receive caller information after subscribing to a Caller ID service, this message will not be displayed.
Store V.M. no.	<ul style="list-style-type: none"> ● You have not stored the voice mail access number. Store the number.

6.3. Troubleshooting

If you still have difficulties after following the instructions in this section, disconnect the base unit's AC adaptor, then reconnect the base unit's AC adaptor. Remove the batteries from the handset, and then insert the batteries into the handset again.



General use

Problem	Cause/solution
The unit does not work.	<ul style="list-style-type: none"> • Make sure the batteries are installed correctly. • Fully charge the batteries. • Check the connections. • Unplug the base unit's AC adaptor to reset the unit. Reconnect the adaptor and try again. • The handset has not been registered to the base unit. Register the handset.
I cannot hear a dial tone.	<ul style="list-style-type: none"> • The base unit's AC adaptor or telephone line cord is not connected. Check the connections. • If you are using a splitter to connect the unit, remove the splitter and connect the unit to the wall jack directly. If the unit operates properly, check the splitter. • Disconnect the base unit from the telephone line and connect the line to a known working telephone. If the working telephone operates properly, contact our service personnel to have the unit repaired. If the working telephone does not operate properly, contact your service provider/telephone company.
The indicator on the handset flashes slowly.	<ul style="list-style-type: none"> • New messages have been recorded. Listen to the new messages. • New voice mail messages have been recorded. Listen to the new voice mail messages.

Programmable settings

Problem	Cause/solution
I have changed the display language to a language I cannot read.	<ul style="list-style-type: none"> • Change the display language.
While programming, the handset starts to ring.	<ul style="list-style-type: none"> • A call is being received. Answer the call and start again after hanging up.
I cannot register a handset to a base unit.	<ul style="list-style-type: none"> • The maximum number of handsets (6) is already registered to the base unit. Cancel unused handset registrations from the base unit. • Place the handset and the base unit away from other electrical appliances.

Battery recharge

Problem	Cause/solution
The handset beeps and/or  flashes.	<ul style="list-style-type: none"> ● Battery charge is low. Fully charge the batteries.
I fully charged the batteries, but  still flashes or  is displayed.	<ul style="list-style-type: none"> ● Clean the charge contacts and charge again. ● It is time to replace the batteries.
I fully charged the batteries, but the operating time seems to be shorter.	<ul style="list-style-type: none"> ● Clean the battery ends (\oplus, \ominus) and the charge contacts with a dry cloth and charge again.

Making/answering calls, intercom

Problem	Cause/solution
 is displayed.	<ul style="list-style-type: none"> ● The handset is too far from the base unit. Move closer. ● The base unit's AC adaptor is not properly connected. Reconnect AC adaptor to the base unit. ● You are using the handset or base unit in an area with high electrical interference. Re-position the base unit and use the handset away from sources of interference. ● The handset is not registered to the base unit. Register it.
Noise is heard, sound cuts in and out.	<ul style="list-style-type: none"> ● You are using the handset or base unit in an area with high electrical interference. Re-position the base unit and use the handset away from sources of interference. ● Move closer to the base unit. ● If you use a DSL/ADSL service, we recommend connecting a DSL/ADSL filter between the base unit and the telephone line jack. Contact your DSL/ADSL provider for details.
The handset and/or base unit does not ring.	<ul style="list-style-type: none"> ● The ringer volume is turned off. Adjust the ringer volume. ● Silent mode is turned on. Turn it off.
I cannot make a call.	<ul style="list-style-type: none"> ● The dialing mode may be set incorrectly. Change the setting. ● The handset is too far from the base unit. Move closer and try again.
I cannot make long distance calls.	<ul style="list-style-type: none"> ● Make sure that you have long distance service.

Caller ID/Talking Caller ID

Problem	Cause/solution
Caller information is not displayed.	<ul style="list-style-type: none"> ● You must subscribe to Caller ID service. Contact your service provider/telephone company for details. ● If your unit is connected to any additional telephone equipment such as a Caller ID box or cordless telephone line jack, plug the unit directly into the wall jack. ● If you use a DSL/ADSL service, we recommend connecting a DSL/ADSL filter between the base unit and the telephone line jack. Contact your DSL/ADSL provider for details. ● The name display service may not be available in some areas. Contact your service provider/telephone company for details. ● Other telephone equipment may be interfering with this unit. Disconnect the other equipment and try again.
Caller information is not announced.	<ul style="list-style-type: none"> ● The handset or base unit's ringer volume is turned off. Adjust it. ● The Talking Caller ID feature is turned off. Turn it on. ● The number of rings for the answering system is set to "2" or "Toll saver". Select a different setting.
Caller information is displayed or announced late.	<ul style="list-style-type: none"> ● Depending on your service provider/telephone company, the unit may display or announce the caller's information at the 2nd ring or later. ● Move closer to the base unit.
The caller list/incoming phone numbers are not edited automatically.	<ul style="list-style-type: none"> ● The Caller ID number auto edit feature is turned off. Turn it on and try again. ● You need to call back the edited number to activate Caller ID number auto edit.
I cannot dial the phone number edited in the caller list.	<ul style="list-style-type: none"> ● The phone number you dialed might have been edited incorrectly (for example, the long distance "1" or the area code is missing). Edit the phone number with another pattern.
Time on the unit has shifted.	<ul style="list-style-type: none"> ● Incorrect time information from incoming Caller ID changes the time. Set the time adjustment to "Manual" (off).
The 2nd caller's information is not displayed during an outside call.	<ul style="list-style-type: none"> ● In order to use Caller ID, call waiting, or Call Waiting Caller ID (CWID), you must first contact your service provider/telephone company and subscribe to the desired service. After subscribing, you may need to contact your service provider/telephone company again to activate this specific service, even if you already subscribed to both Caller ID and Call Waiting with Caller ID services (CWID).

Answering system

Problem	Cause/solution
The unit does not record new messages.	<ul style="list-style-type: none"> • The answering system is turned off. Turn it on. • The message memory is full. Erase unnecessary messages. • The recording time is set to "Greeting only". Change the setting. • If you subscribe to the voice mail service, messages are recorded by your service provider/telephone company, not your telephone. Change the unit's number of rings setting or contact your service provider/telephone company.
I cannot operate the answering system.	<ul style="list-style-type: none"> • Someone is using the unit. Wait for the other user to finish. • A caller is leaving a message. Wait for the caller to finish. • The handset is too far from the base unit. Move closer.
I cannot operate the answering system remotely.	<ul style="list-style-type: none"> • You are entering the wrong remote access code. If you forgot the remote access code, store a new remote access code. • Press each key firmly. • The answering system is turned off. Turn it on. • You are using a rotary/pulse telephone. Try again using a touch-tone phone.
While recording a greeting message or listening to messages, the unit rings and the operation stops.	<ul style="list-style-type: none"> • A call is being received. Answer the call and try again later.

Liquid damage

Problem	Cause/solution
Liquid or other form of moisture has entered the handset/base unit.	<ul style="list-style-type: none"> • Disconnect the AC adaptor and telephone line cord from the base unit. Remove the batteries from the handset and leave to dry for at least 3 days. After the handset/base unit are completely dry, reconnect the AC adaptor and telephone line cord. Insert the batteries and charge fully before use. If the unit does not work properly, contact an authorized service center.

Caution:

- To avoid permanent damage, do not use a microwave oven to speed up the drying process.

7 Schematic Diagram

7.1. For Schematic Diagram

7.1.1. Base Unit (Schematic Diagram (Base Unit_Main))

7.1.1.1. Acoustic Testing Mode

Press “STOP”, “▶▶” and “▶” simultaneously, and insert the plug of AC adaptor.
It is easier to measure the transmit level with acoustic testing mode.

Notes:

1. DC voltage measurements are taken with voltmeter from the negative voltage line.

Important Safety Notice:

Components identified by ⚠ mark have special characteristics important for safety. When replacing any of these components, use only the manufacturer's specified parts.

2. The schematic diagrams may be modified at any time with the development of new technology.

7.1.2. Handset (Schematic Diagram (Handset_Main))

Notes:

1. DC voltage measurements are taken with an oscilloscope or a tester with a ground.
2. The schematic diagrams may be modified at any time with the development of new technology.

7.2. Schematic Diagram (Base Unit_Main)

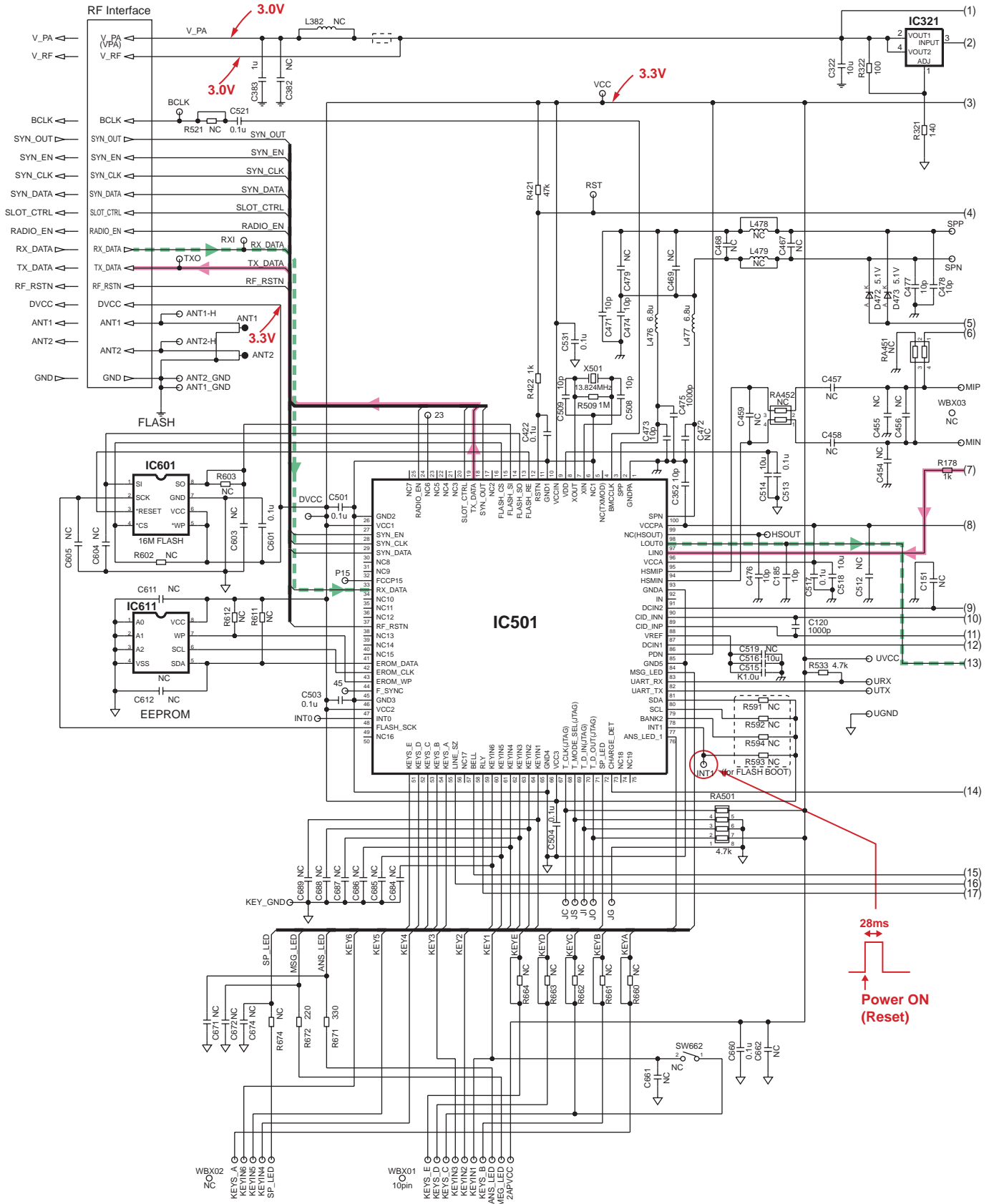

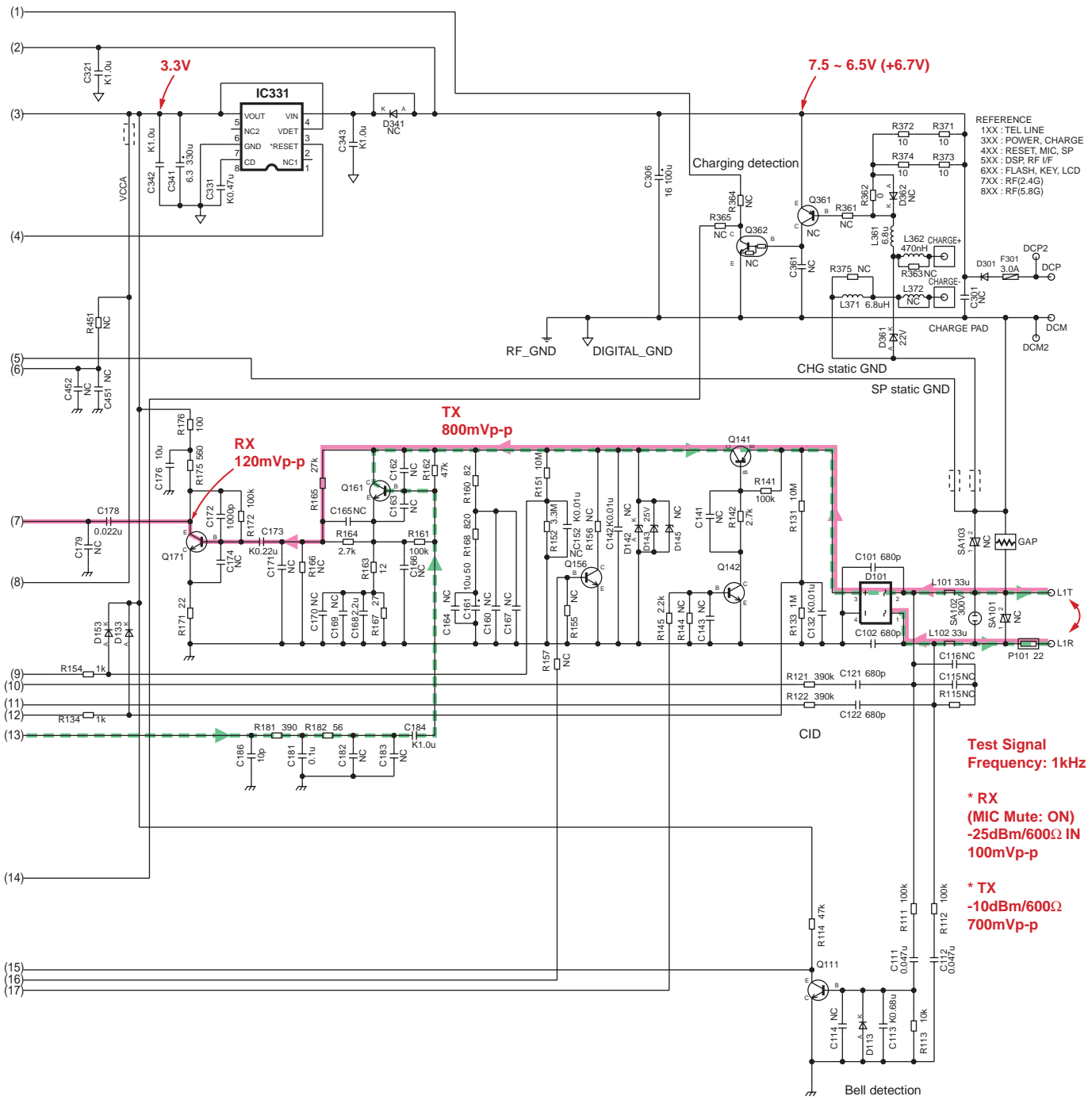

NC: No Components

KX-TG6431 SCHEMATIC DIAGRAM (Base Unit_Main)

7.3. Schematic Diagram (Base Unit_RF Part)

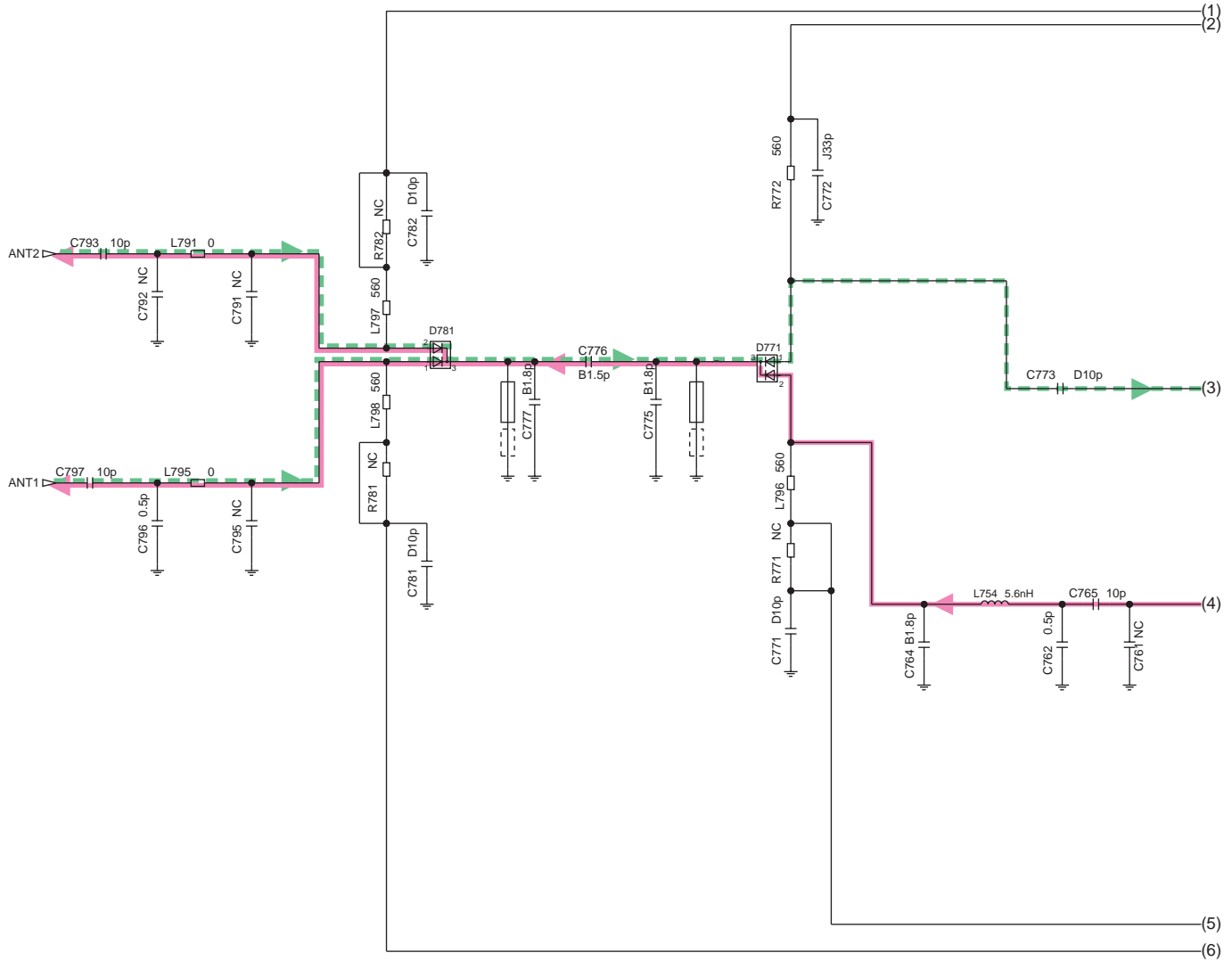

NC: No Components

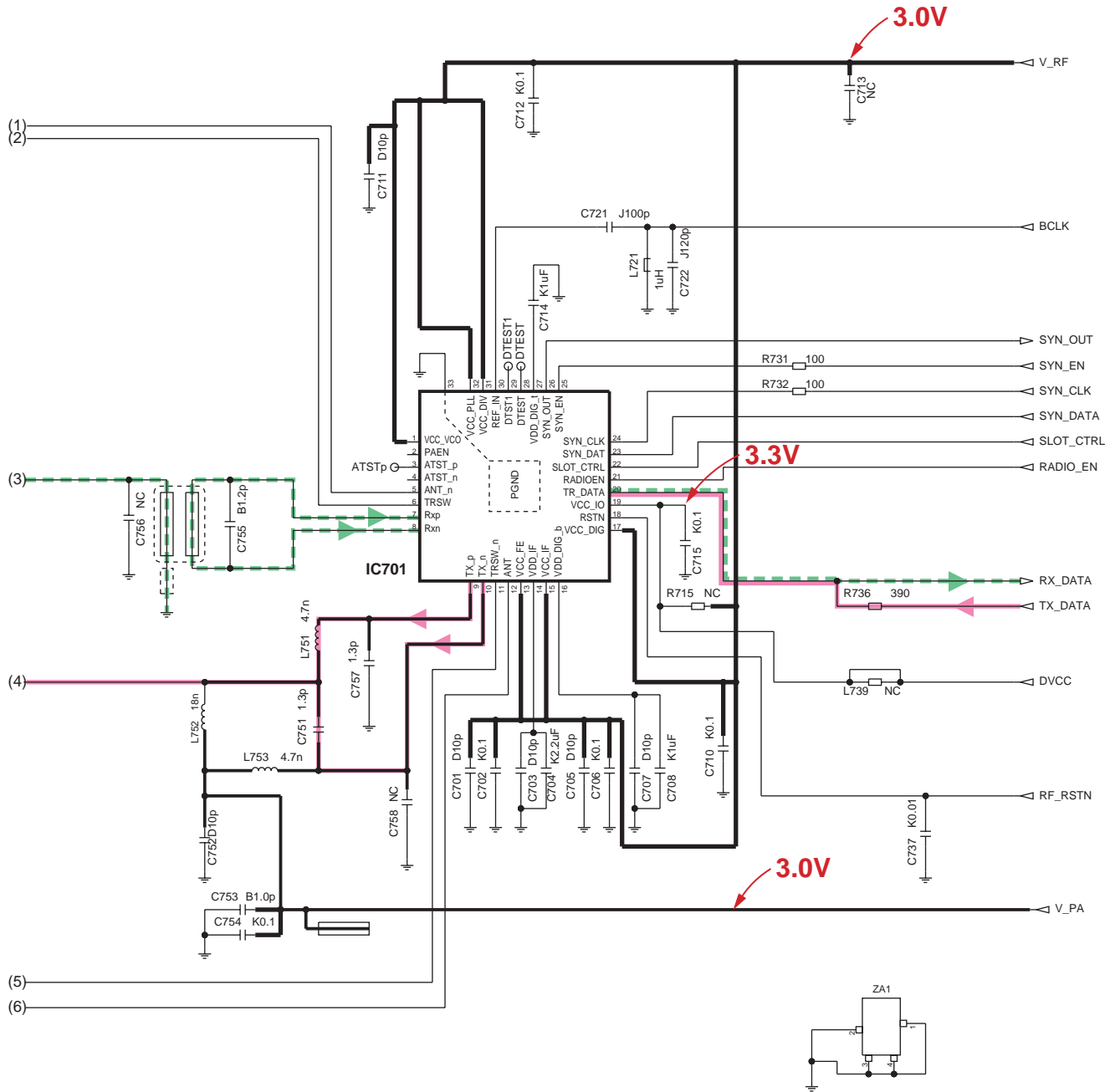

NC: No Components

KX-TG6431 SCHEMATIC DIAGRAM (Base Unit_RF Part)

7.4. Schematic Diagram (Base Unit_Operation)

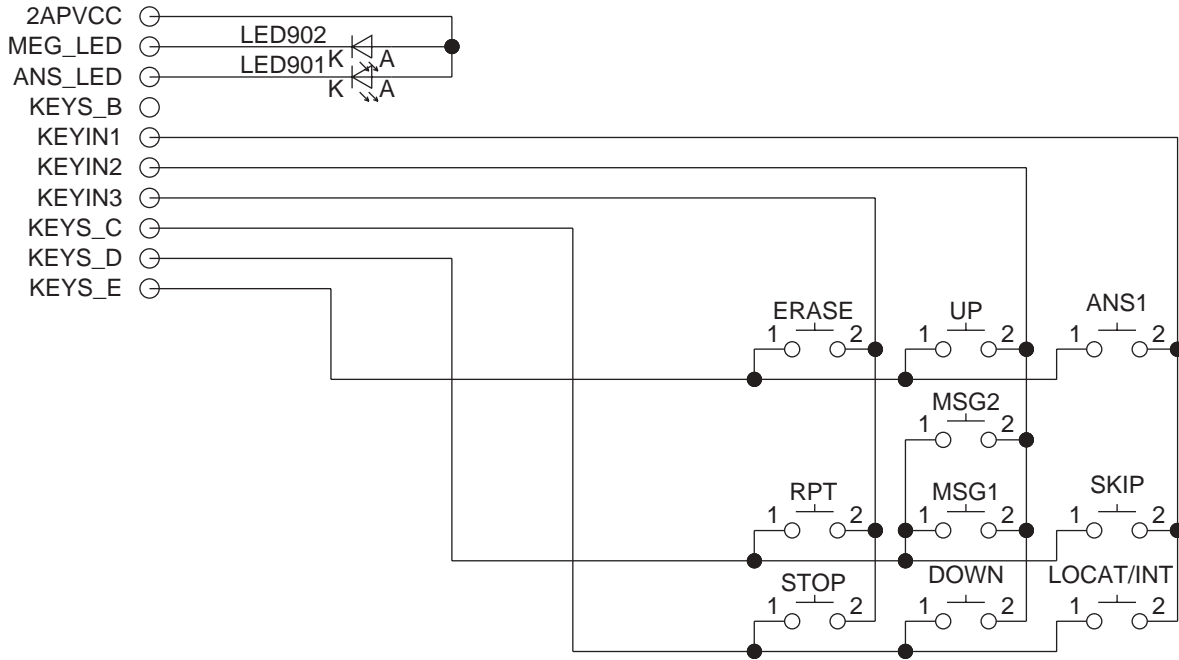

NC: No Components

KX-TG6431 SCHEMATIC DIAGRAM (Base Unit_Operation)

Memo

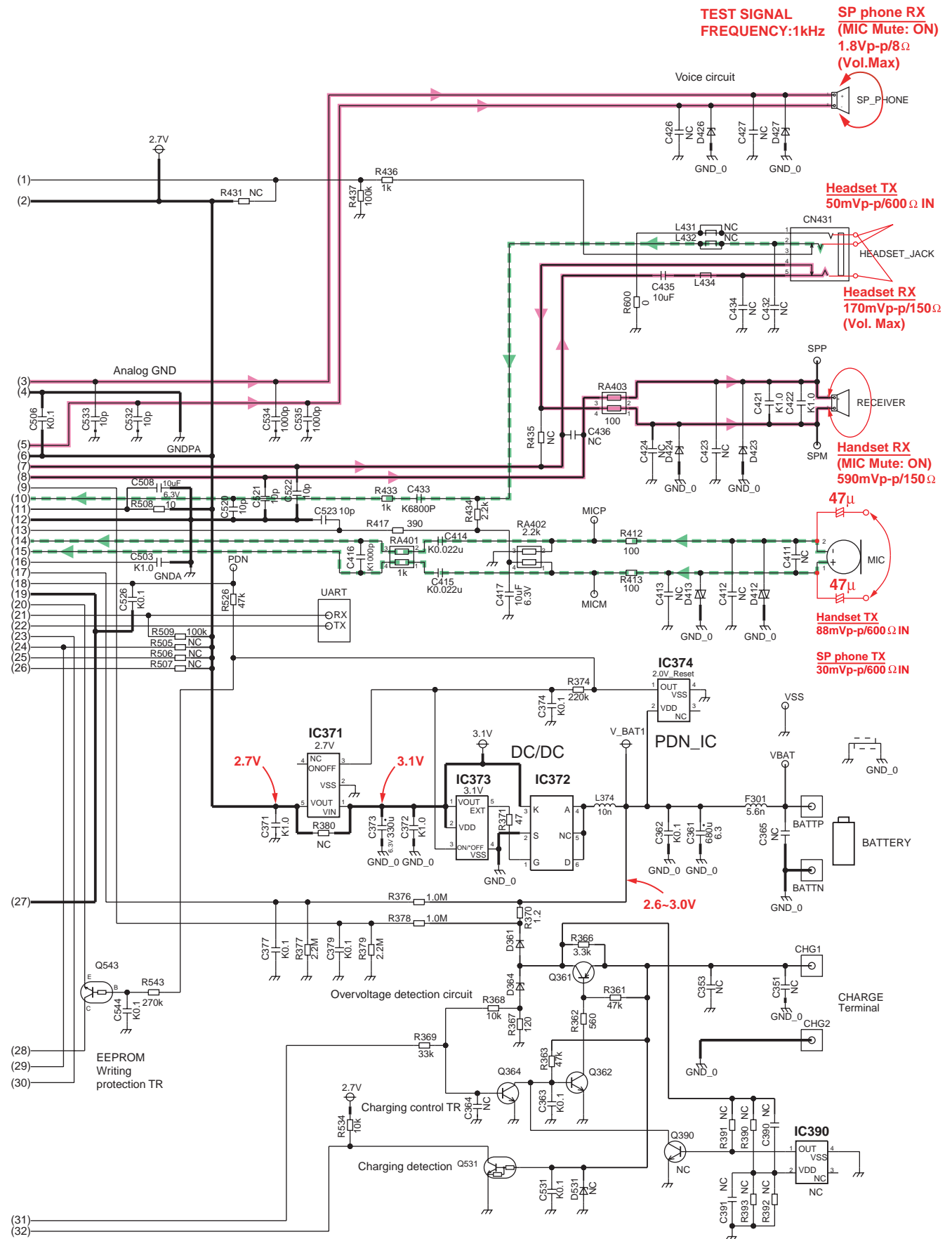

TEST SIGNAL
FREQUENCY: 1kHz

SP phone RX
(MIC Mute: ON)
1.8Vp-p/8Ω
(Vol. Max)

Headset TX
50mVp-p/600Ω IN

Headset RX
170mVp-p/150Ω
(Vol. Max)

Handset RX
(MIC Mute: ON)
590mVp-p/150Ω

Handset TX
88mVp-p/600Ω IN

SP phone TX
30mVp-p/600Ω IN

NC: No Components
KX-TGA641 SCHEMATIC DIAGRAM (Handset_Main)

7.6. Schematic Diagram (Handset_RF Part)

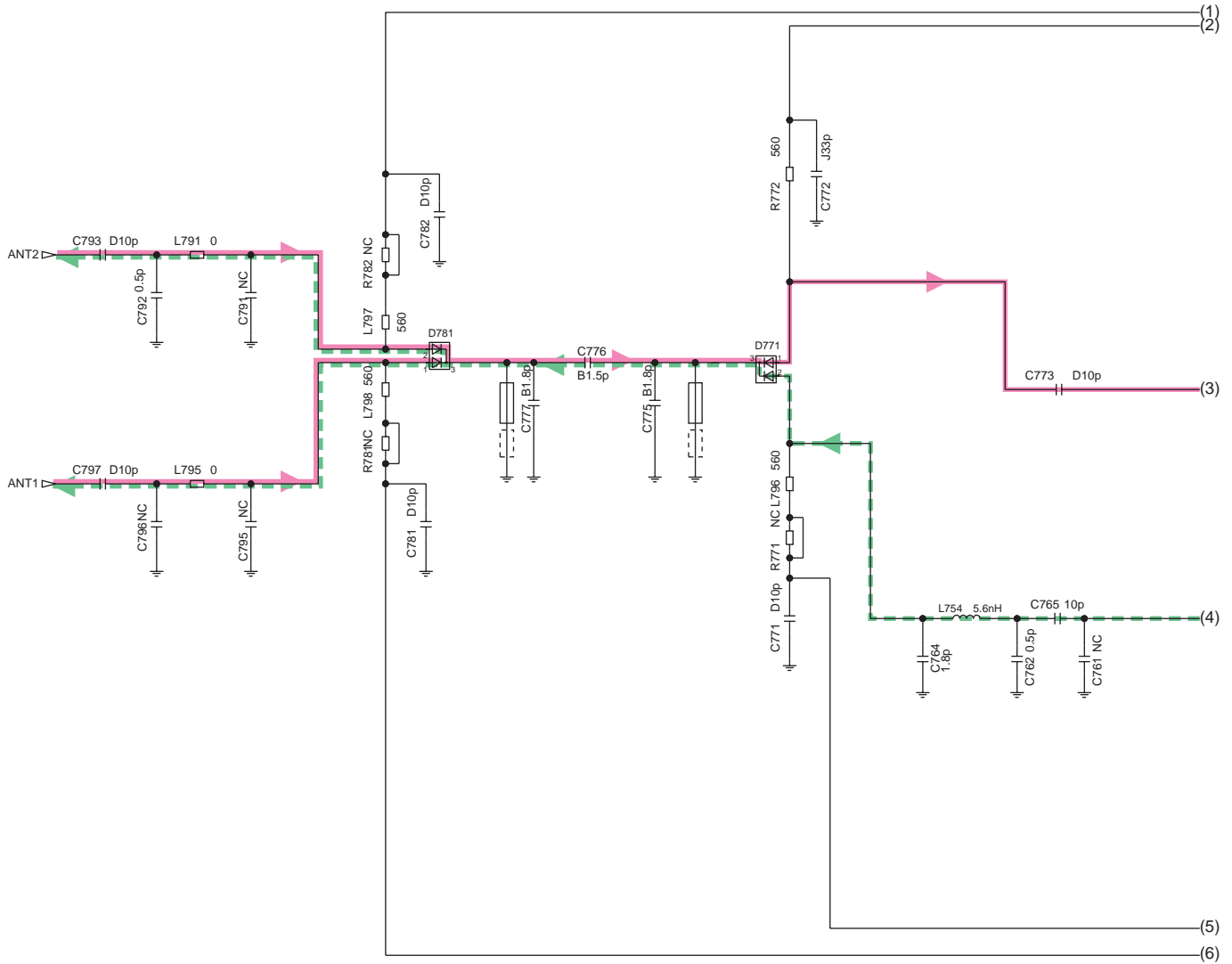

NC: No Components

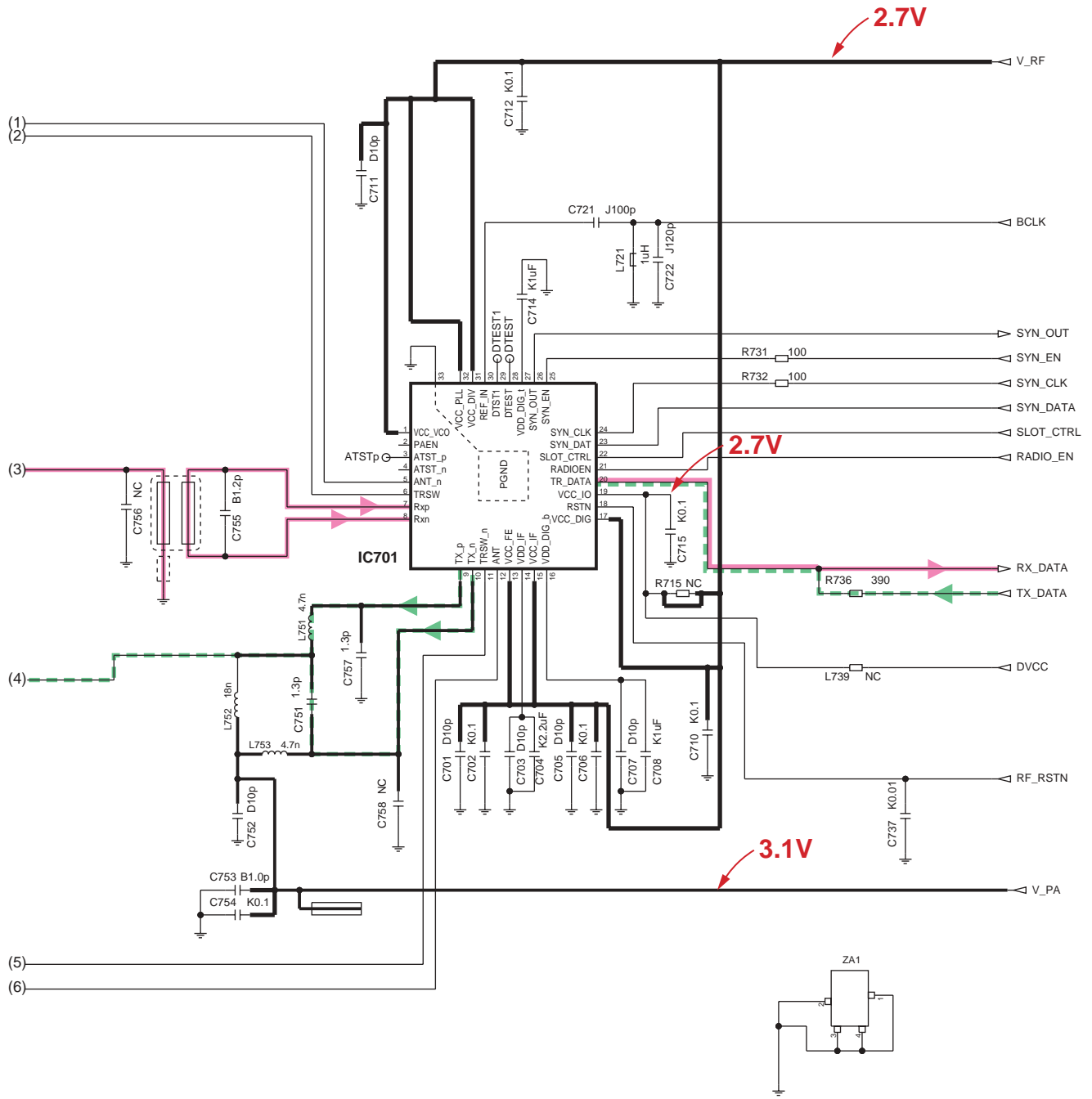

NC: No Components

KX-TGA641 SCHEMATIC DIAGRAM (Handset_RF Part)

8 Exploded View and Replacement Parts List

1. RTL (Retention Time Limited)

Note:

The "RTL" marking indicates that its Retention Time is Limited.

When production is discontinued, this item will continue to be available only for a specific period of time.

This period of time depends on the type of item, and the local laws governing parts and product retention. At the end of this period, the item will no longer be available.

2. Important safety notice

Components identified by the Δ mark indicates special characteristics important for safety. When replacing any of these components, only use specified manufacture's parts.

3. ISO code (Example: ABS-94HB) of the remarks column shows quality of the material and a flame resisting grade about plastics.

Note:

(*1) You can download and refer to the Operating Instructions (Instruction book) on TSN Server.

Safety	Ref. No.	Part No.	Part Name & Description	Remarks
Δ	A1	PQLV219Z	AC ADAPTOR	
	A2	PQJA10075Z	CORD, TELEPHONE	
	A3	PNKL1010Z1	STAND, WALL MOUNT	ABS-HB
	A4	PNQX1624Y	INSTRUCTION BOOK (*1)	
	A5	PNQW1485Y	LEAFLET, QUICK GUIDE (for English)	
	A6	PNKE1029Z1	HANGER, BELT CLIP	ABS-HB
	A7	PNHS1079Z	SPACER, BATTERY COVER	
	A8	PNKK1027Z1	LID, BATTERY COVER	ABS-HB
	A9	PNYNTGA641TR	LID, BATTERY COVER ASS'Y	ABS-HB

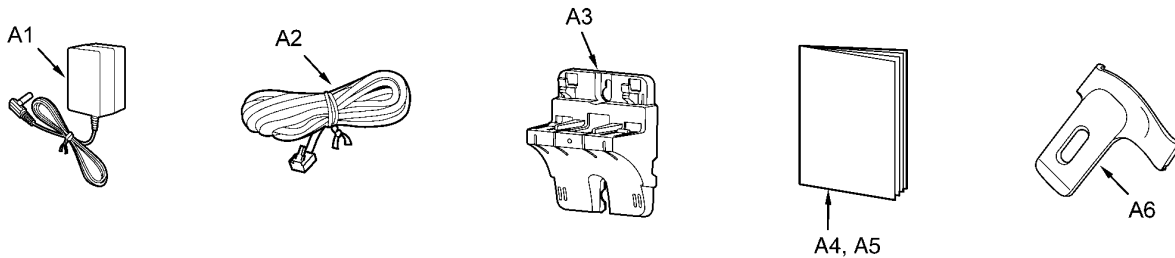

* Attach the SPACER (A7) to the exact location described below.

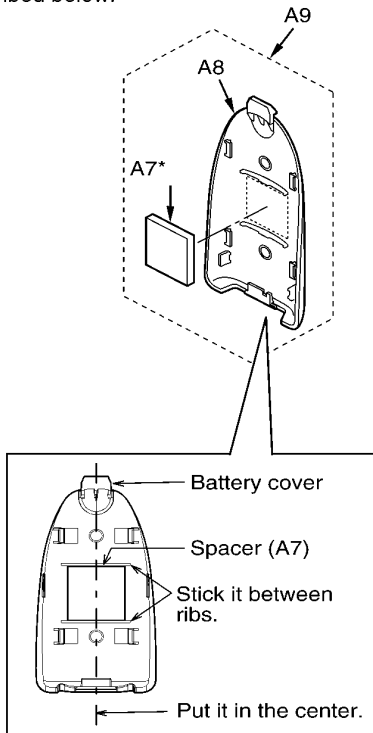

T.I
KXTG6431M
KXTG6431T
KXTGA641M
KXTGA641T