

Service Manual

Telephone Equipment

Model No. **KX-TG4763B**
KX-TGA470B
KX-TGA405B

Digital Cordless Answering System

B: Black Version
(for U.S.A.)

DECT
6.0



KX-TGA470B
(Handset)

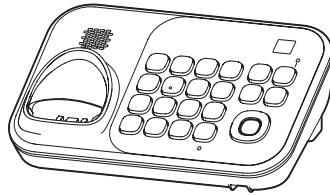

KX-TG4741B
(Base Unit)



(Charger Unit)



(Range Extender)

Configuration for each model

Model No	Base Unit	Handset	Charger Unit	Range Extender	Expandable
KX-TG4763	1 (TG4741)	3 (TGA470)	2	1	Up to 6
KX-TGA470*		1 (TGA470)	1		

*KX-TGA470 is also an optional accessory, which contains a handset and a charger.

 **WARNING**

This service information is designed for experienced repair technicians only and is not designed for use by the general public. It does not contain warnings or cautions to advise non-technical individuals of potential dangers in attempting to service a product. Products powered by electricity should be serviced or repaired only by experienced professional technicians. Any attempt to service or repair the product or products dealt with in this service information by anyone else could result in serious injury or death.

IMPORTANT SAFETY NOTICE

There are special components used in this equipment which are important for safety. These parts are marked by  in the Schematic Diagrams, Circuit Board Diagrams, Exploded Views and Replacement Parts List. It is essential that these critical parts should be replaced with manufacturer's specified parts to prevent shock, fire or other hazards. Do not modify the original design without permission of manufacturer.

IMPORTANT INFORMATION ABOUT LEAD FREE, (PbF), SOLDERING

If lead free solder was used in the manufacture of this product, the printed circuit boards will be marked PbF. Standard leaded, (Pb), solder can be used as usual on boards without the PbF mark. When this mark does appear, please read and follow the special instructions described in this manual on the use of PbF and how it might be permissible to use Pb solder during service and repair work.

- When you note the serial number, write down all 11 digits. The serial number may be found on the bottom of the unit.
- The illustrations in this Service Manual may vary slightly from the actual product.

TABLE OF CONTENTS

	PAGE		PAGE
1 Safety Precautions -----	4	15.2. Circuit Board (Base Unit_Operation)-----	87
1.1. For Service Technicians -----	4	15.3. Circuit Board (Handset_Main) -----	89
2 Warning -----	4	15.4. Circuit Board (Handset_LED)-----	91
2.1. Battery Caution-----	4	15.5. Circuit Board (Charger Unit)-----	92
2.2. About Lead Free Solder (PbF: Pb free)-----	5	15.6. Circuit Board (Range Extender)-----	93
2.3. Discarding of P. C. Board-----	5	16 Exploded View and Replacement Parts List -----	95
3 Specifications -----	6	16.1. Cabinet and Electrical Parts (Base Unit)-----	95
4 Technical Descriptions -----	7	16.2. Cabinet and Electrical Parts (Handset)-----	96
4.1. US-DECT Description -----	7	16.3. Cabinet and Electrical Parts (Charger Unit)-----	97
4.2. Block Diagram (Base Unit_Main)-----	9	16.4. Cabinet and Electrical Parts (Range Extender)-----	98
4.3. Block Diagram (Base Unit_RF Part)-----	10	16.5. Accessories and Packing Materials -----	99
4.4. Circuit Operation (Base Unit)-----	11	16.6. Replacement Parts List-----	101
4.5. Block Diagram (Handset)-----	18		
4.6. Block Diagram (Handset_RF Part)-----	19		
4.7. Circuit Operation (Handset)-----	20		
4.8. Circuit Operation (Charger Unit)-----	21		
4.9. Block Diagram (Range Extender_Main)-----	22		
4.10. Block Diagram (Range Extender_RF Part)-----	22		
4.11. Circuit Operation (Range Extender)-----	23		
4.12. Signal Route -----	25		
5 Location of Controls and Components -----	27		
6 Installation Instructions -----	27		
7 Operating Instructions -----	27		
8 Test Mode -----	28		
8.1. Engineering Mode -----	28		
9 Service Mode -----	32		
9.1. How to Clear User Setting (Handset Only)-----	32		
10 Troubleshooting Guide -----	33		
10.1. Troubleshooting Flowchart-----	33		
11 Disassembly and Assembly Instructions -----	48		
11.1. Disassembly Instructions -----	48		
11.2. How to Replace the Base Unit LCD -----	53		
11.3. How to Replace the Handset LCD -----	55		
12 Measurements and Adjustments -----	56		
12.1. Equipment Required -----	56		
12.2. The Setting Method of JIG -----	56		
12.3. Adjustment Standard (Base Unit)-----	60		
12.4. Adjustment Standard (Charger Unit)-----	61		
12.5. Adjustment Standard (Range Extender)-----	62		
12.6. Adjustment Standard (Handset) -----	63		
12.7. Things to Do after Replacing IC or X'tal -----	64		
12.8. Frequency Table -----	66		
13 Miscellaneous -----	67		
13.1. How to Replace the LLP (Leadless Leadframe Package) IC-----	67		
13.2. How to Replace the Flat Package IC-----	69		
13.3. Terminal Guide of the ICs, Transistors and Diodes -----	71		
14 Schematic Diagram -----	73		
14.1. For Schematic Diagram-----	73		
14.2. Schematic Diagram (Base Unit_Main)-----	74		
14.3. Schematic Diagram (Base Unit_Operation) -----	76		
14.4. Schematic Diagram (Handset_Main)-----	78		
14.5. Schematic Diagram (Handset_LED)-----	80		
14.6. Schematic Diagram (Charger Unit) -----	81		
14.7. Schematic Diagram (Range Extender)-----	82		
15 Printed Circuit Board -----	85		
15.1. Circuit Board (Base Unit_Main)-----	85		

1 Safety Precautions

1.1. For Service Technicians

- **Repair service shall be provided in accordance with repair technology information such as service manual so as to prevent fires, injury or electric shock, which can be caused by improper repair work.**

1. When repair services are provided, neither the products nor their parts or members shall be remodeled.
2. If a lead wire assembly is supplied as a repair part, the lead wire assembly shall be replaced.
3. FASTON terminals shall be plugged straight in and unplugged straight out.

- **ICs and LSIs are vulnerable to static electricity.**

When repairing, the following precautions will help prevent recurring malfunctions.

1. Cover plastic parts boxes with aluminum foil.
2. Ground the soldering irons.
3. Use a conductive mat on worktable.
4. Do not grasp IC or LSI pins with bare fingers.

2 Warning

2.1. Battery Caution

Risk of explosion if battery is replaced by an incorrect type. Dispose of used batteries according to the instructions.

Attention:



A nickel metal hydride battery that is recyclable powers the product you have purchased.

Please call 1-800-8-BATTERY (1-800-822-8837) for information on how to recycle this battery.

2.2. About Lead Free Solder (PbF: Pb free)

Note:

In the information below, Pb, the symbol for lead in the periodic table of elements, will refer to standard solder or solder that contains lead.

We will use PbF solder when discussing the lead free solder used in our manufacturing process which is made from Tin (Sn), Silver (Ag), and Copper (Cu).

This model, and others like it, manufactured using lead free solder will have PbF stamped on the PCB. For service and repair work we suggest using the same type of solder.

Caution

- PbF solder has a melting point that is 50 °F ~ 70 °F (30 °C ~ 40 °C) higher than Pb solder. Please use a soldering iron with temperature control and adjust it to 700 °F ± 20 °F (370 °C ± 10 °C).
- Exercise care while using higher temperature soldering irons.:
Do not heat the PCB for too long time in order to prevent solder splash or damage to the PCB.
- PbF solder will tend to splash if it is heated much higher than its melting point, approximately 1100 °F (600 °C).
- When applying PbF solder to double layered boards, please check the component side for excess which may flow onto the opposite side (See the figure below).

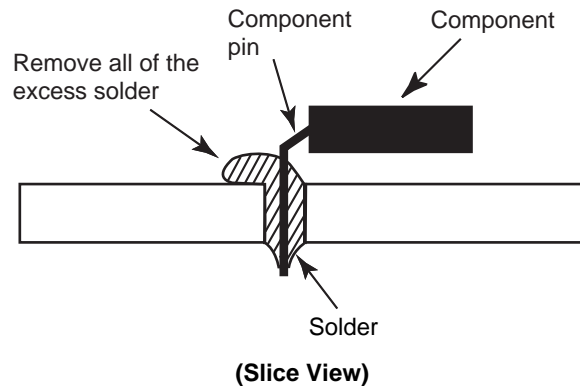

2.2.1. Suggested PbF Solder

There are several types of PbF solder available commercially. While this product is manufactured using Tin, Silver, and Copper (Sn+Ag+Cu), you can also use Tin and Copper (Sn+Cu), or Tin, Zinc, and Bismuth (Sn+Zn+Bi). Please check the manufacturer's specific instructions for the melting points of their products and any precautions for using their product with other materials.

The following lead free (PbF) solder wire sizes are recommended for service of this product: 0.3 mm, 0.6 mm and 1.0 mm.

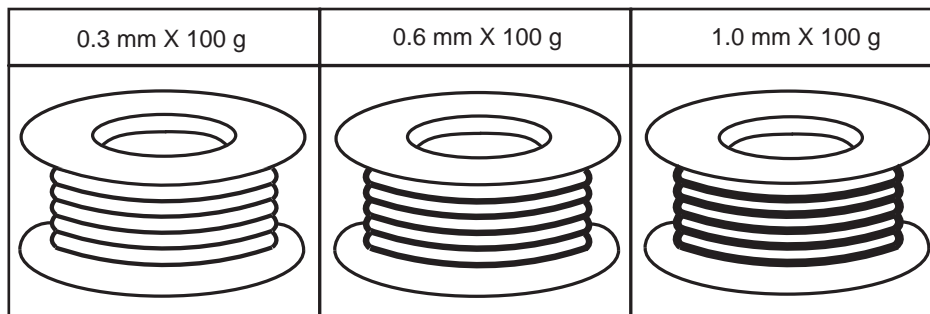

2.3. Discarding of P. C. Board

When discarding P. C. Board, delete all personal information such as telephone directory and caller list or scrap P. C. Board.

3 Specifications

- | | |
|--|---|
| <ul style="list-style-type: none"> ■ Standard:
DECT 6.0 (Digital Enhanced Cordless Telecommunications 6.0) ■ Number of channels:
60 Duplex Channels ■ Frequency range:
1.92 GHz to 1.93 GHz ■ Duplex procedure:
TDMA (Time Division Multiple Access) ■ Channel spacing:
1.728MHz | <ul style="list-style-type: none"> ■ Bit rate:
1,152 kbit/s ■ Modulation:
GFSK (Gaussian Frequency Shift Keying) ■ RF transmission power:
115 mW (max.) ■ Voice coding:
ADPCM 32 kbit/s |
|--|---|

	Base Unit	Handset	Charger	Range Extender
Power source	AC Adaptor (PNLV226Z, 120 V AC, 60 Hz)	Rechargeable Ni-MH battery AAA (R03) size (1.2 V 550 mAh)	AC Adaptor (PNLV226Z, 120 V AC, 60 Hz)	AC Adaptor (PQLV219Y, 120V AV, 60 Hz)
Receiving Method	Super Heterodyne	Super Heterodyne	—	Super Heterodyne
Oscillation Method	PLL synthesizer	PLL synthesizer	—	PLL synthesizer
Detecting Method	Quadrature Discriminator	Quadrature Discriminator	—	Quadrature Discriminator
Tolerance of OSC Frequency	13.824 MHz ±100 Hz	13.824 MHz ±100 Hz	—	13.824 MHz ±100 Hz
Modulation Method	Frequency Modulation	Frequency Modulation	—	Frequency Modulation
ID Code	40 bit	40 bit	—	40 bit
Ringer Equivalence No. (REN)	0.1B	—	—	—
Dialing Mode	—	Tone (DTMF)/Pulse	—	—
Redial	—	Up to 48 digits	—	—
Speed Dialer	—	Up to 32 digits (Phonebook)	—	—
Power Consumption	Standby: Approx. 0.9 W Maximum: Approx. 3.8 W	11 days at Standby, 13 hours at Talk	Standby: Approx. 0.1 W, Maximum: Approx. 2.0 W	Standby: Approx. 1.0W Maximum: Approx. 1.8W
Operating Conditions	0 °C - 40 °C (32 °F - 104 °F) 20 % - 80 % relative air humidity (dry)	0 °C - 40 °C (32 °F - 104 °F) 20 % - 80 % relative air humidity (dry)	0 °C - 40 °C (32 °F - 104 °F) 20 % - 80 % relative air humidity (dry)	0 °C - 40 °C (32 °F - 104 °F) 20 % - 80 % relative air humidity (dry)
Dimensions (W x D x H)	Approx. 200 mm x 119 mm x 71 mm	Approx. 54 mm x 34 mm x 174 mm	Approx. 73 mm x 76 mm x 43 mm	Approx. 82 mm x 111 mm x 39mm
Mass (Weight)	Approx. 350 g	Approx. 150 g	Approx. 50 g	Approx. 80 g

Note:

- Design and specifications are subject to change without notice.

Note for Service:

- **Operation range:** Up to 300 m outdoors, Up to 50 m indoors, depending on the condition.
- **Analog telephone connection:** Telephone Line
- **Optional headset:** KX-TCA60, KX-TCA93, KX-TCA400, KX-TCA430
- **Optional Range extender:** KX-TGA405

4 Technical Descriptions

4.1. US-DECT Description

The frequency range of 1.92 GHz-1.93 GHz is used. Transmitting and receiving carrier between base unit and handset is same frequency. Refer to **Frequency Table** (P.66).

4.1.1. TDD Frame Format

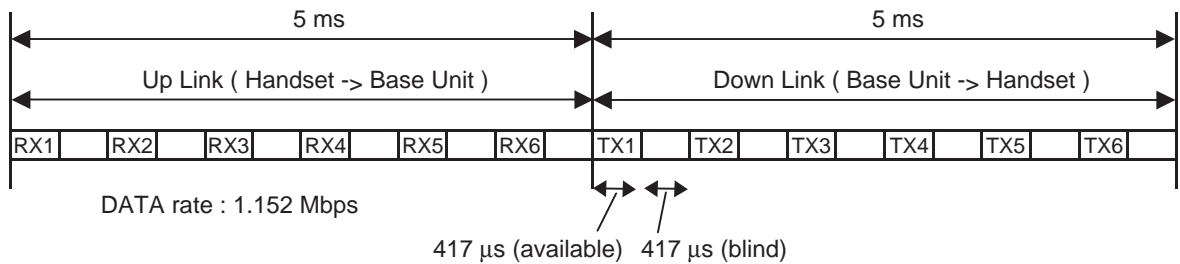

4.1.2. TDMA system

This system is the cycles of 10 ms, and has 6 duplex paths, but maximum duplex communication path is 5 because of dummy bearer use.

In 1 slot 417 μs, the 10 ms of voice data is transmitted.

• 2 - Handsets Link

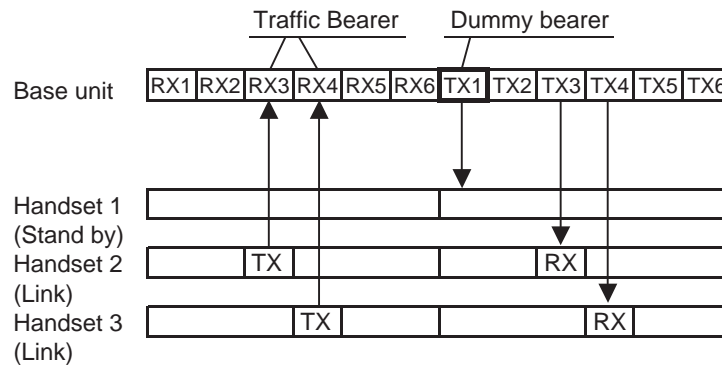

Traffic Bearer

A link is established between base unit and handset.

The state where duplex communication is performed.

Handset doesn't make up duplex in no free RF channels because of interference. (*1)

Dummy Bearer

Base unit sends Dummy-data to the all stand-by state handsets.

Handsets receive that data for synchronization and monitoring request from the base unit.

Base unit doesn't send Dummy bearer in no free RF channels because of interference. (*1)

Note:

(*1) It is a feature under FCC 15 regulation and for interference avoidance.

In the case of checking RF parts, it is better in least interference condition.

4.1.3. Signal Flowchart in the Radio Parts

Reception

Base unit:

A voice signal from TEL line is encoded to digital data and converted into a 1.9GHz modulated radio signal by BBIC(IC501). The RF signal, after which is amplified in BBIC, is fed to selected antenna.

Handset:

As for a handset RF, RF signal is received in one antenna.

BBIC down-converts to 864 kHz IF signal from RX signal and demodulates it to digital data "RXDATA".

BBIC (IC1) converts RXDATA into a voice signal and outputs it to speaker.

Transmission

Handset:

A voice signal from microphone is encoded to digital data and converted into a 1.9GHz modulated radio signal by BBIC(IC1). The RF signal, after which is amplified in BBIC, is fed to an antenna.

Base unit:

As for a base unit RF, RF signal is received in two antennas.

BBIC (IC501) compares RF signal levels and selects the antenna to be used. Then BBIC down-converts to 864 kHz IF signal from RX signal in the selected antenna, and demodulates it to digital data "RXDATA".

BBIC (IC501) converts RXDATA into a voice signal and outputs it to TEL line.

4.2. Block Diagram (Base Unit_Main)

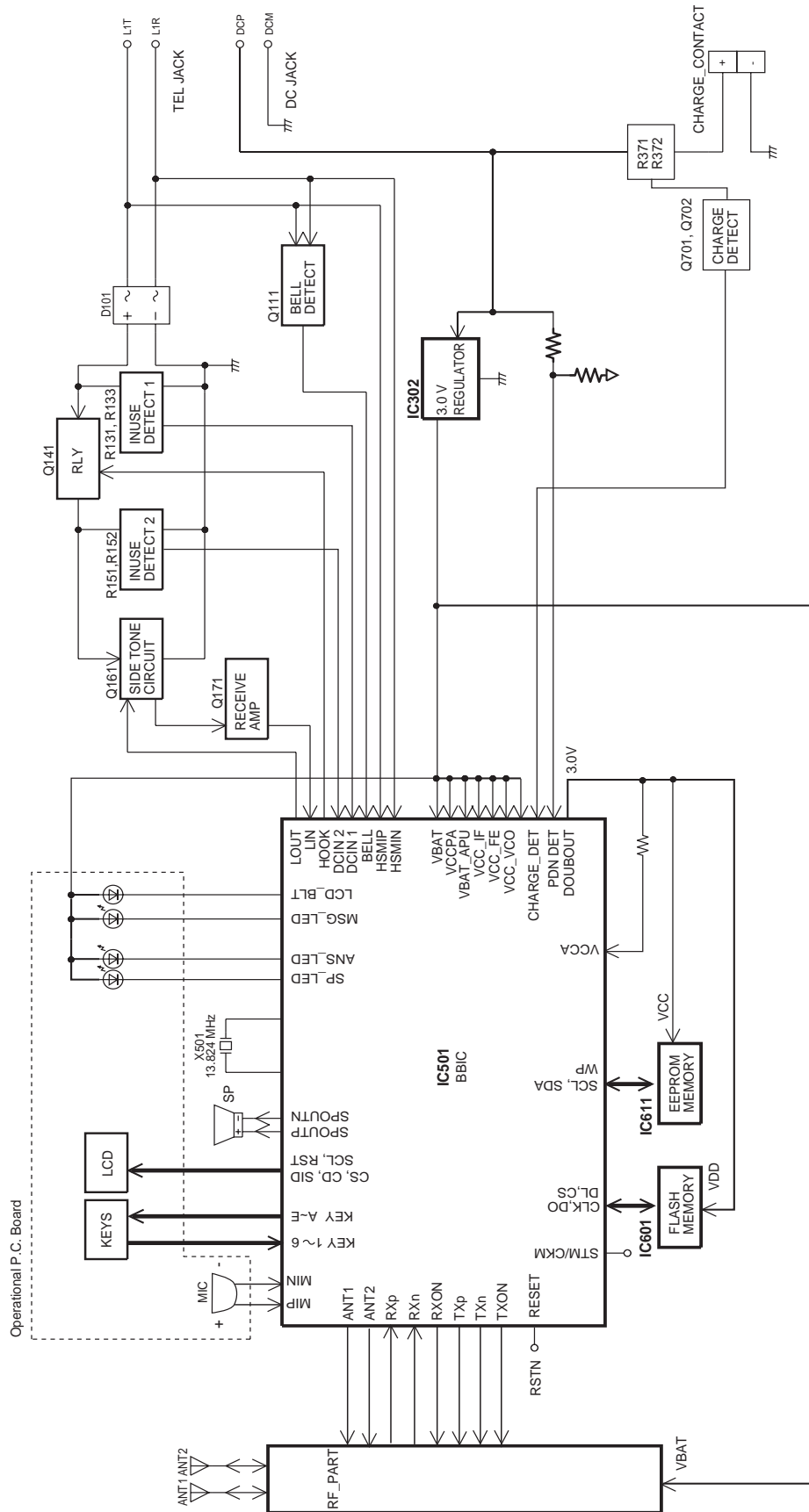

KX-TG4763 BLOCK DIAGRAM (Base Unit_Main)

4.3. Block Diagram (Base Unit_RF Part)

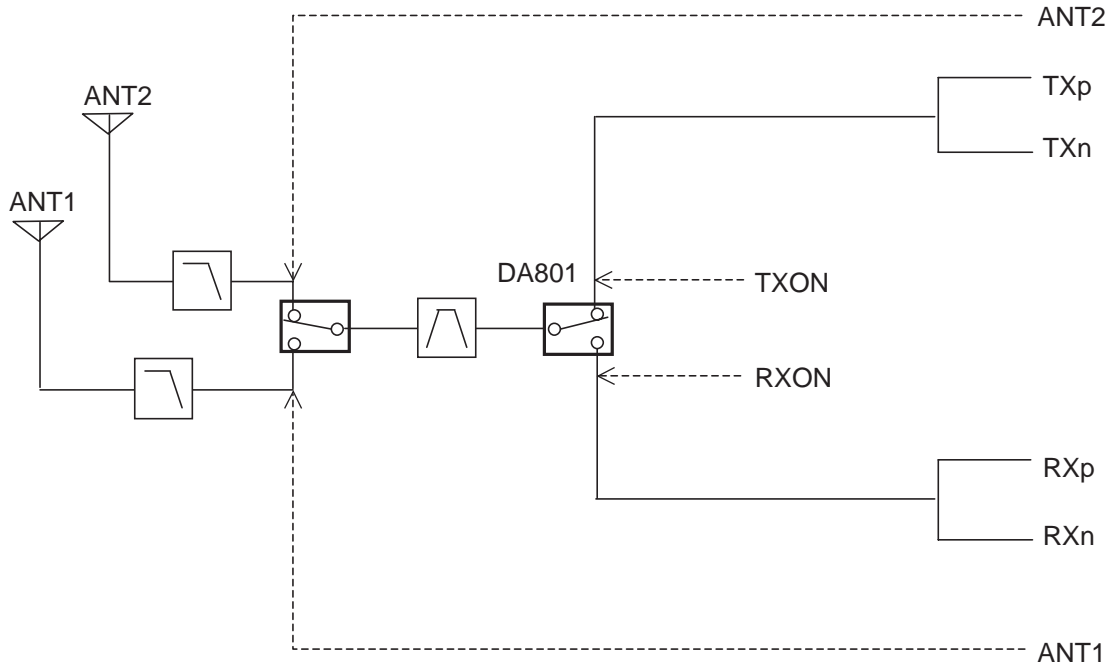

KX-TG4763 BLOCK DIAGRAM (Base Unit_RF Part)

4.4. Circuit Operation (Base Unit)

General Description:

(BBIC, Flash Memory, EEPROM) is a digital speech/signal processing system that implements all the functions of speech compression, record and playback, and memory management required in a digital telephone answering machine.

The BBIC system is fully controlled by a host processor. The host processor provides activation and control of all that functions as follows.

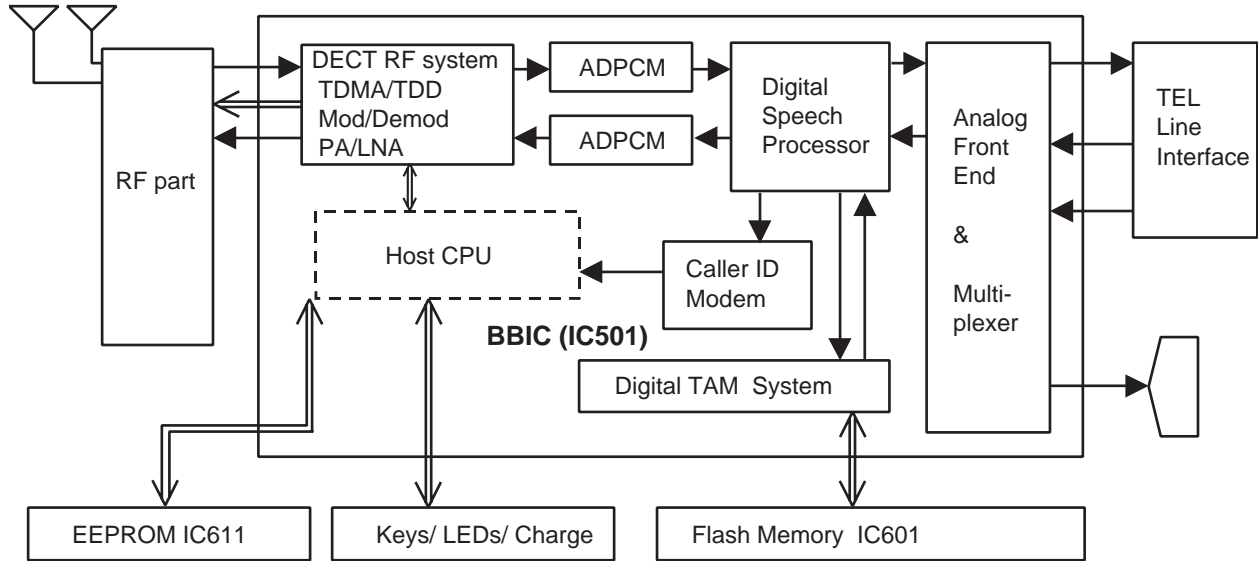

4.4.1. BBIC (Base Band IC: IC501)

- **Voice Message Recording/Play back**

The BBIC system uses a proprietary speech compression technique to record and store voice message in Flash Memory.

An error correction algorithm is used to enable playback of these messages from the Flash Memory.

- **DTMF Generator**

When the DTMF data from the handset is received, the DTMF signal is output.

- **Synthesized Voice (Pre-recorded message)**

The BBIC implements synthesized Voice, utilizing the built in speech detector and a Flash Memory, which stored the vocabulary.

- **Caller ID demodulation**

The BBIC implements monitor and demodulate the FSK/DTMF signals that provide CID information from the Central Office.

- **Digital Switching**

The voice signal from telephone line is transmitted to the handset or the voice signal from the handset is transmitted to the Telephone line, etc. They are determined by the signal path route operation of voice signal.

- **Block Interface Circuit**

RF part, LED, Key scan, Speaker, Telephone line.

4.4.2. Flash Memory (IC601)

Following information data is stored.

- **Voice signal**

ex: Pre-recorded Greeting message, Incoming message

4.4.3. EEPROM (IC611)

Following information data is stored.

- **Settings**

ex: message numbers, ID code, Flash Time, Tone/Pulse

4.4.4. Power Supply Circuit/Reset Circuit

The power supply voltage from AC adaptor is converted to VBAT (3.0V) in IC302. And +3.0V for peripherals and analog part is insulated from VBAT by Doubler of BBIC.

Circuit Operation:

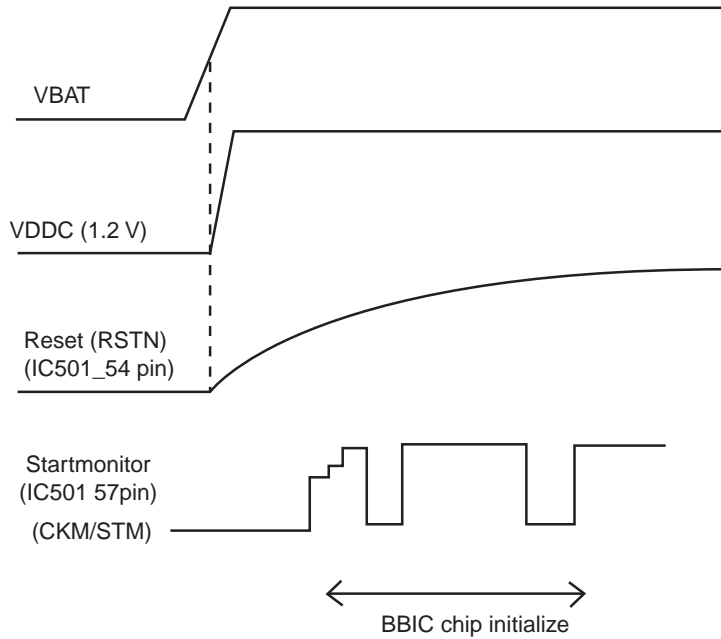
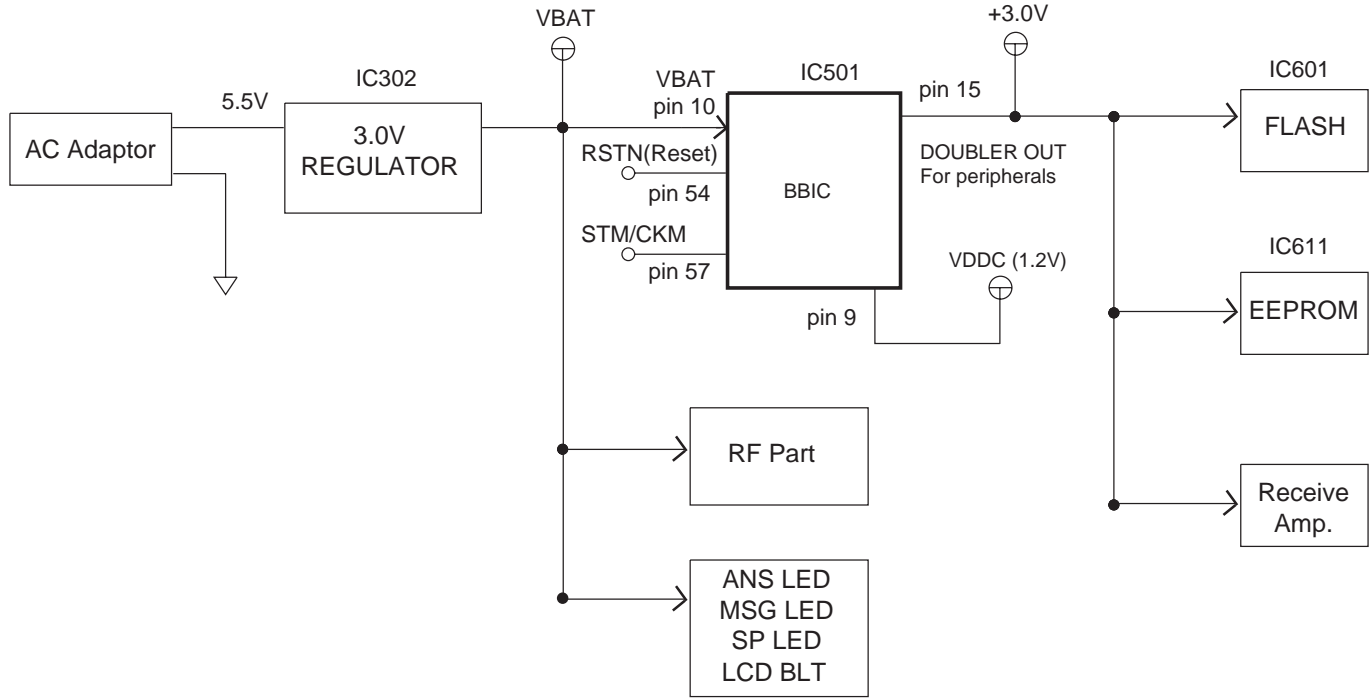

4.4.4.1. Charge Circuit

The voltage from the AC adaptor is supplied to the charge circuits.

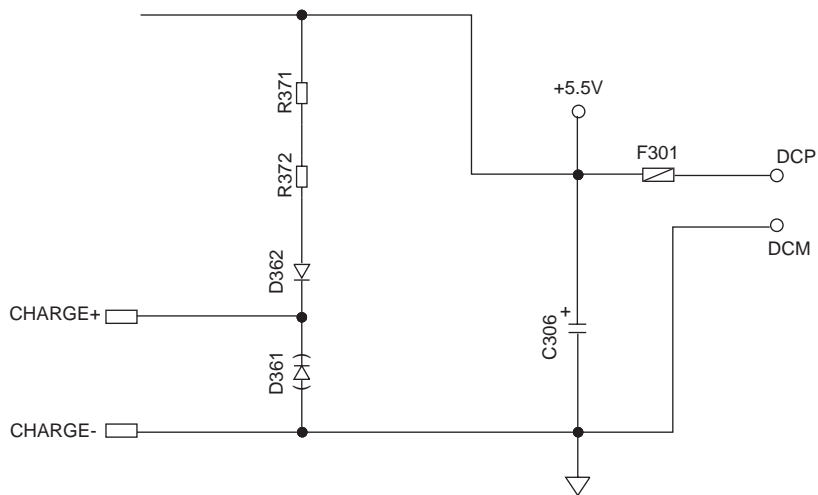

4.4.5. Telephone Line Interface

Telephone Line Interface Circuit:

Function

- Bell signal detection
- ON/OFF hook and pulse dial circuit
- Side tone circuit

Bell signal detection and OFF HOOK circuit:

In the idle mode, Q141 is open to cut the DC loop current and decrease the ring load. When ring voltage appears at the Tip (T) and Ring (R) leads (When the telephone rings), the AC ring voltage is transferred as follows:

T → L101 → R111 → C111 → Q111 → BBIC pin 59

When the CPU (BBIC) detects a ring signal, Q141 turns on, thus providing an off-hook condition (active DC current flow through the circuit). Following signal flow is the DC current flow.

T → L101 → D101 → Q141 → Q161 → R163 → R167 → D101 → L102 → P101 → R

ON HOOK Circuit:

Q141 is open, Q141 is connected as to cut the DC loop current and to cut the voice signal. The unit is consequently in an on-hook condition.

Pulse Dial Circuit:

Pin 6 of BBIC turns Q141 ON/OFF to make the pulse dialing.

Side Tone Circuit:

Basically this circuit prevents the TX signal from feeding back to RX signal. As for this unit, TX signal feed back from Q161 is canceled by the canceller circuit of BBIC.

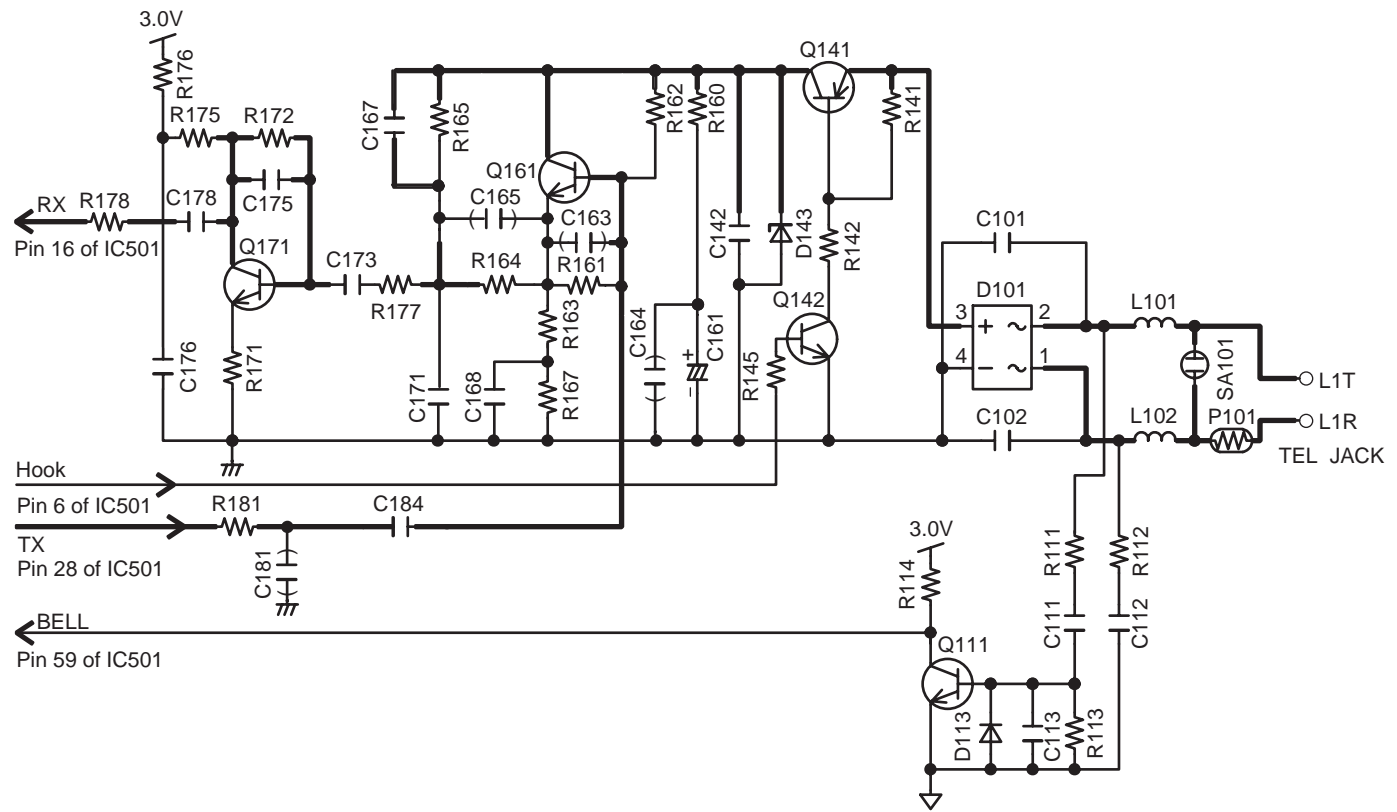

4.4.6. Parallel Connection Detect Circuit/Auto Disconnect Circuit

Function:

In order to disable call waiting and stutter tone functions when using telephones connected in parallel, it is necessary to have a circuit that judges whether a telephone connected in parallel is in use or not. This circuit determines whether the telephone connected in parallel is on hook or off hook by detecting changes in the T/R voltage.

Circuit Operation:

Parallel connection detection when on hook:

When on hook, the voltage is monitored at pin 17 of IC501. There is no parallel connection if the voltage is 0.54 V or higher, while a parallel connection is deemed to exist if the voltage is lower.

Parallel connection detection when off hook:

When off hook, the voltage is monitored at pin 18 of IC501; the presence/absence of a parallel connection is determined by detecting the voltage changes.

If the Auto disconnect function is ON and statuses are Hold, receiving ICM, OGM transmitting, BBIC disconnects the line after detecting parallel connection is off hook.

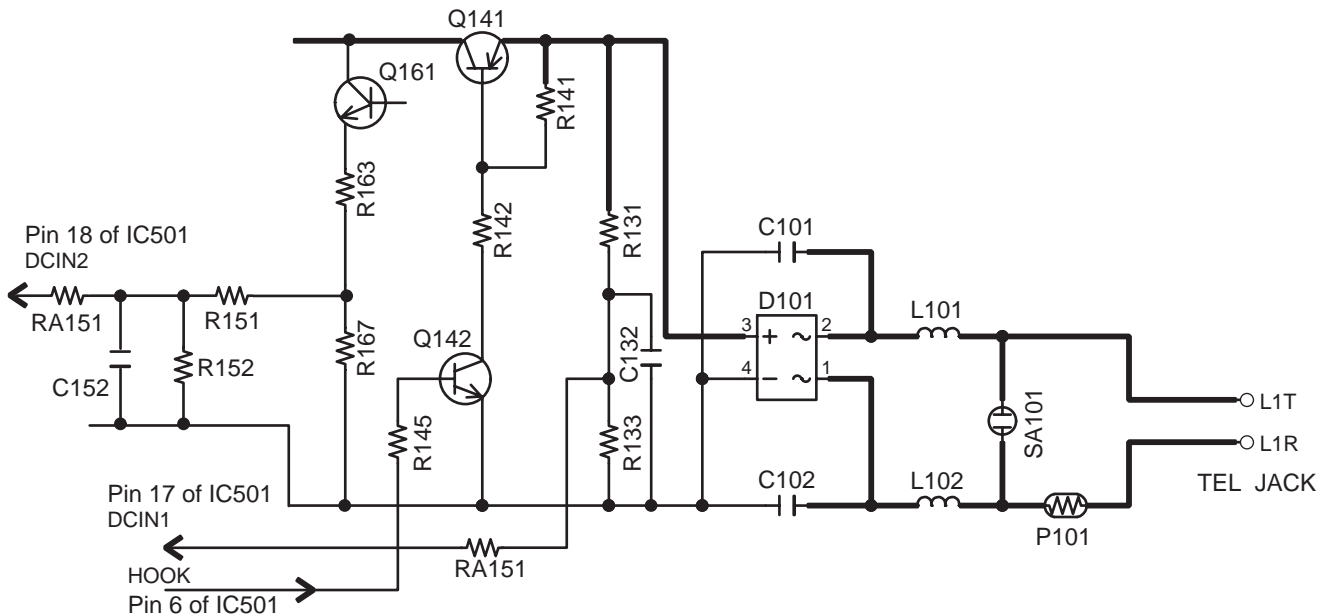

4.4.7. Calling Line Identification (Caller ID)/Call Waiting Caller ID

Function:

Caller ID

The caller ID is a chargeable ID which the user of a telephone circuit obtains by entering a contract with the telephone company to utilize a caller ID service. For this reason, the operation of this circuit assumes that a caller ID service contract has been entered for the circuit being used. The data for the caller ID from the telephone exchange is sent during the interval between the first and second rings of the bell signal. The data from the telephone exchange is a modem signal which is modulated in an FSK (Frequency Shift Keying) * format. Data "1" is a 1200 Hz sine wave, and data "0" is a 2200 Hz sine wave. There are two types of the message format which can be received: i.e. the single message format and plural message format. The plural message format allows to transmit the name and data code information in addition to the time and telephone number data.

*: Also the telephone exchange service provides other formats.

- Single message format

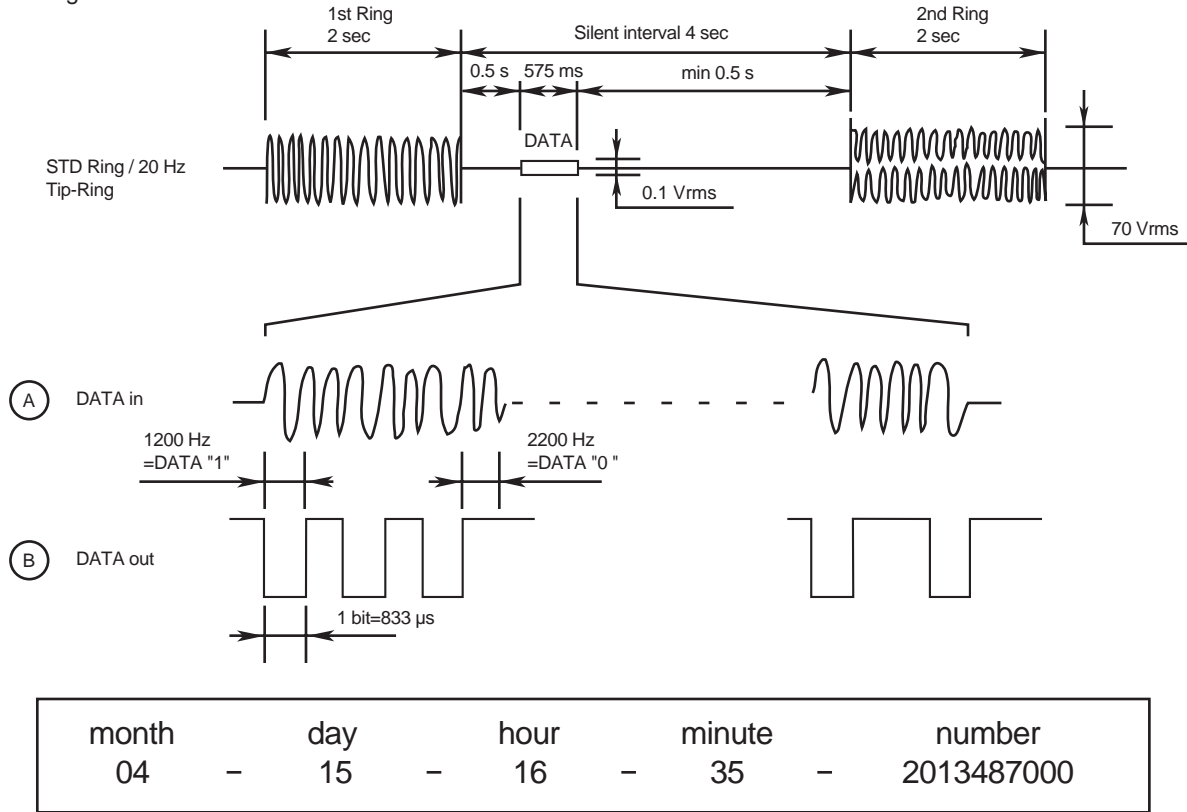

- Plural message format

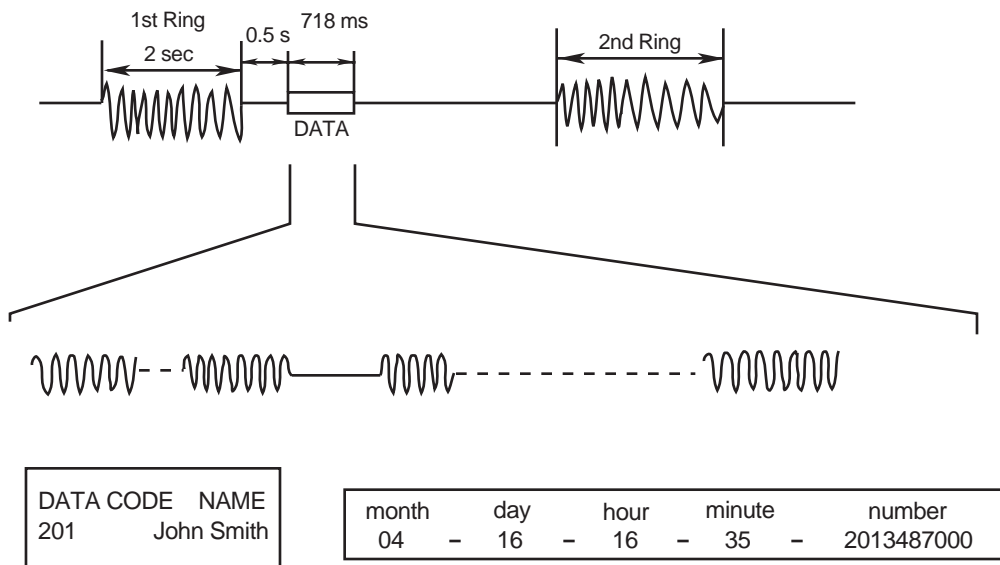

Call Waiting Caller ID

Calling Identity Delivery on Call Waiting (CIDCW) is a CLASS service that allows a customer, while off-hook on an existing call, to receive information about a calling party on a waited call. The transmission of the calling information takes place almost immediately after the customer is alerted to the new call so he/she can use this information to decide whether to take the new call.

Function:

The telephone exchange transmits or receives CAS and ACK signals through each voice RX/TX route. Then FSK data and MARK data pass the following route.

Telephone Line → P101 → L101, L102 → C121, C122 → R121, R122 → IC501 (25, 24).

If the unit deems that a telephone connected in parallel is in use, ACK is not returned even if CAS is received, and the information for the second and subsequent callers is not displayed on the portable handset display.

Call Waiting Format

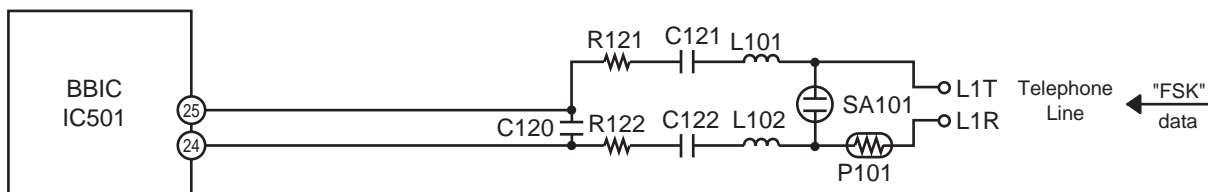
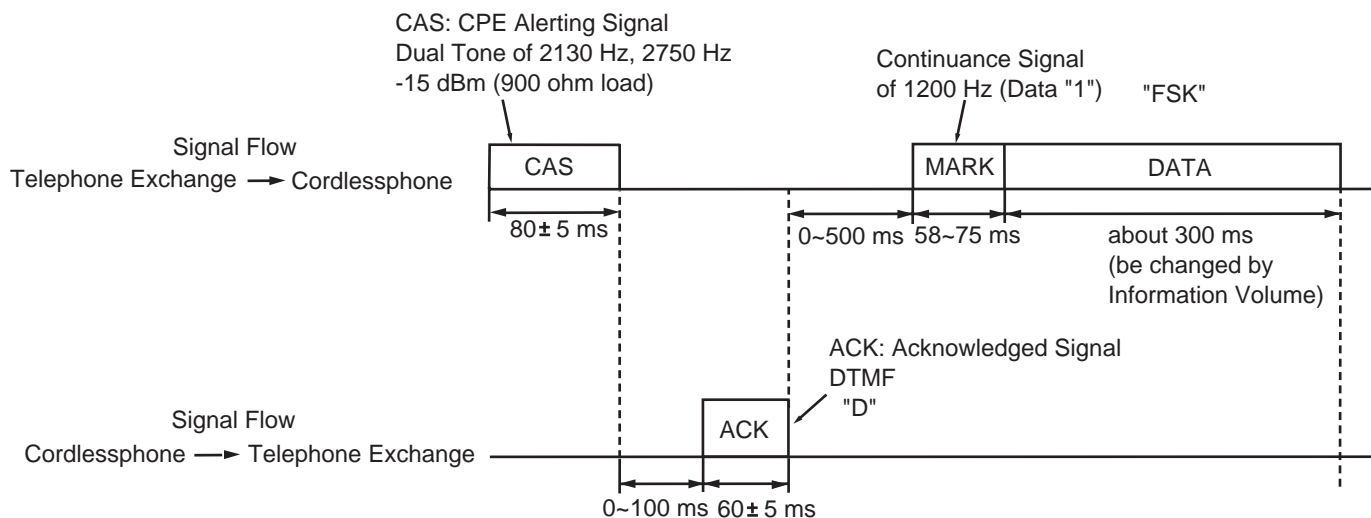

4.5. Block Diagram (Handset)

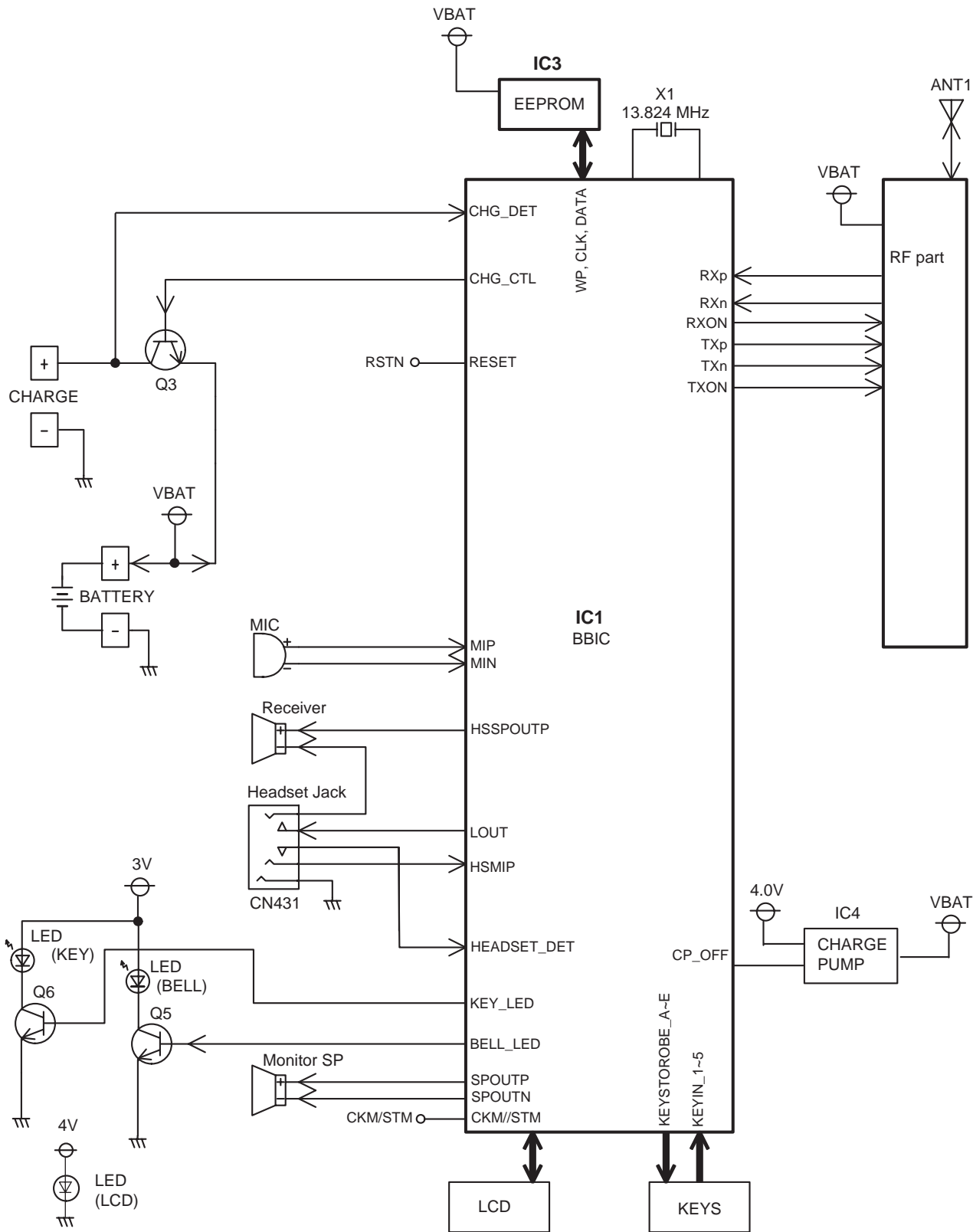

KX-TGA470 BLOCK DIAGRAM (Handset)

4.6. Block Diagram (Handset_RF Part)

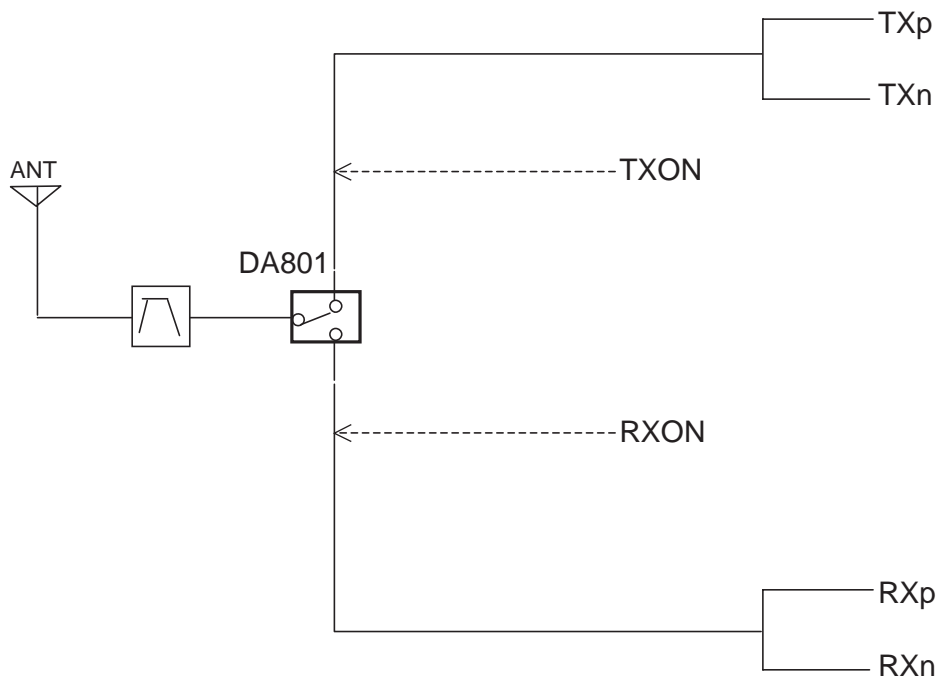

KX-TGA470 BLOCK DIAGRAM (Handset_RF Part)

4.7. Circuit Operation (Handset)

4.7.1. Outline

Handset consists of the following ICs as shown in **Block Diagram (Handset)** (P.18).

- DECT BBIC (**B**ase **B**and IC): IC1
 - All data signals (forming/analyzing ACK or CMD signal)
 - All interfaces (ex: Key, Detector Circuit, Charge, EEPROM, LCD)
- EEPROM: IC3
 - Setting data is stored. (e.g. ID, user setting)

4.7.2. Power Supply Circuit/Reset Circuit

Circuit Operation:

When power on the Handset, the voltage is as follows;

BATTERY(2.2 V ~ 2.6 V: BATT+) → F1 → BBC1 (IC1) 10 pin

The Reset signal generates IC1 (54 pin) and 1.8 V.

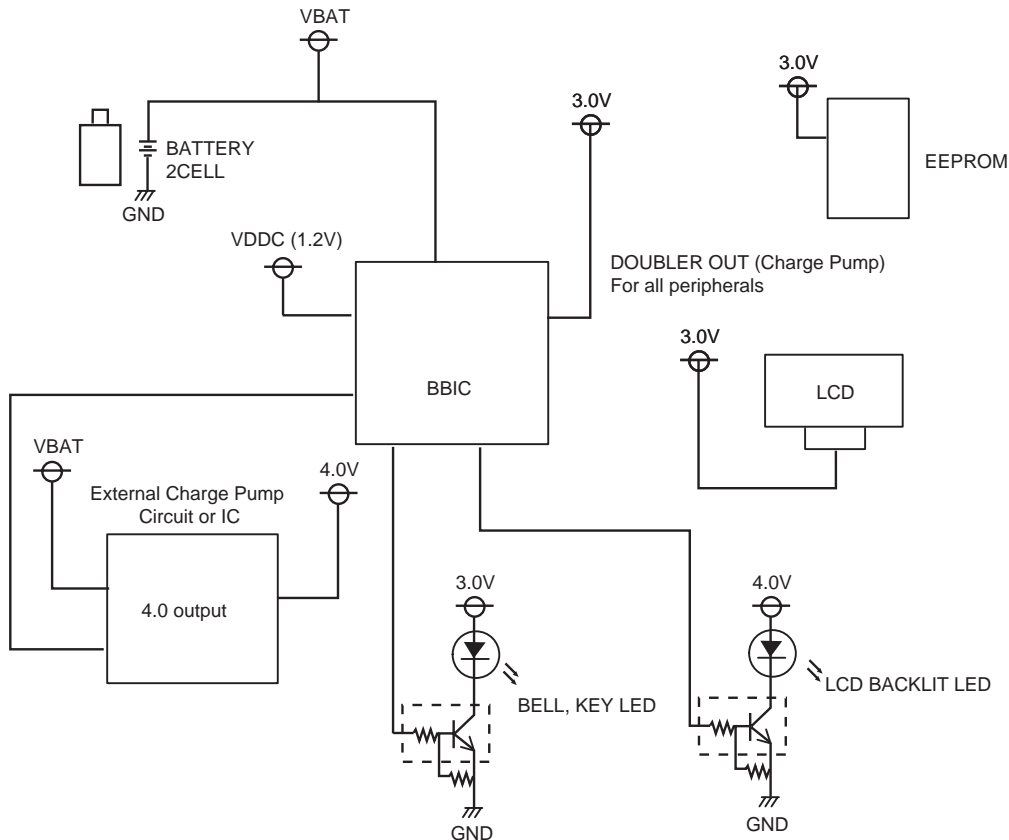
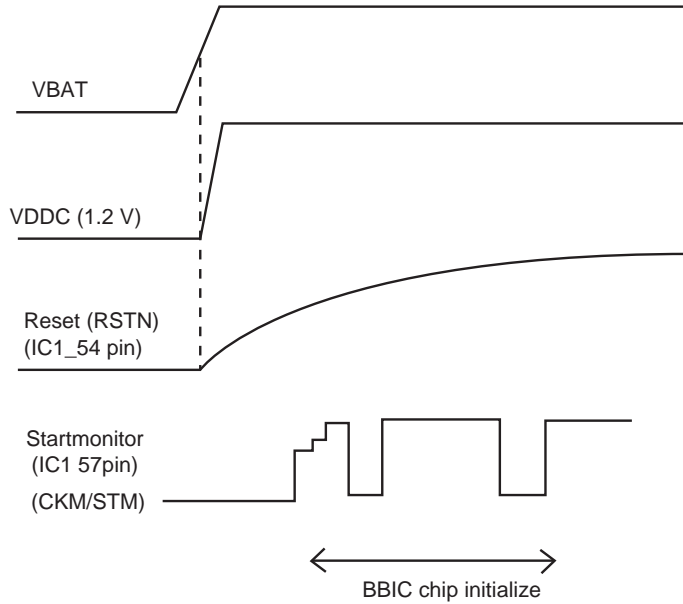

4.7.3. Charge Circuit

Circuit Operation:

When charging the handset on the Base Unit, the charge current is as follows;

DC+(6.5 V) → F301 → R371 → R372 → CHARGE+(Base) → CHARGE+(Handset) → Q4 → D7 → F1 → BATTERY+... Battery...

BATTERY- → R45 → GND → CHARGE-(Handset) → CHARGE-(Base) → GND → DC-(GND)

In this way, the BBIC on Handset detects the fact that the battery is charged.

The charge current is controlled by switching Q9 of Handset.

Refer to Fig.101 in **Power Supply Circuit/Reset Circuit** (P.12).

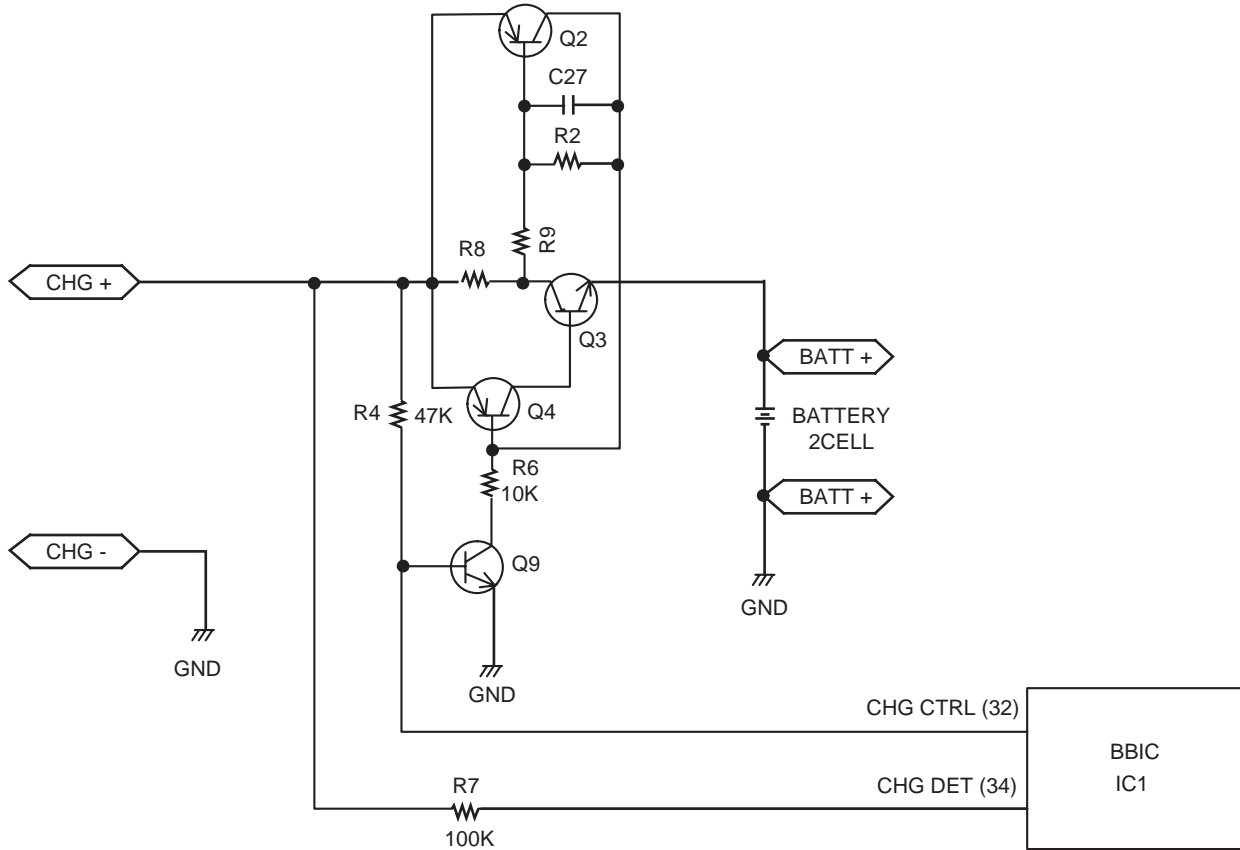

4.7.4. Battery Low/Power Down Detector

Circuit Operation:

“Battery Low” and “Power Down” are detected by BBIC which check the voltage from battery.

The detected voltage is as follows;

- Battery Low
Battery voltage: $V(\text{Batt}) \leq 2.35 \text{ V} \pm 50 \text{ mV}$
The BBIC detects this level and "█" starts flashing.
- Power Down
Battery voltage: $V(\text{Batt}) \leq 2.1 \text{ V} \pm 50 \text{ mV}$
The BBIC detects this level and power down.

4.7.5. Speakerphone

The hands-free loudspeaker at SP+ and SP- is used to generate the ring alarm.

4.8. Circuit Operation (Charger Unit)

Charge control is executed at handset side so that the operation when using charger is also controlled by handset.

Refer to **Circuit Operation (Handset)** (P.20)

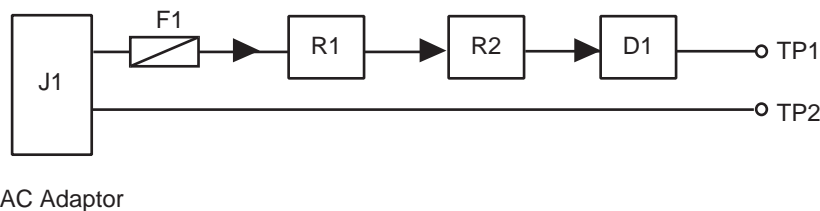

The route for this is as follows: DC+pin of J1(+) → F1 → R1 → CHARGE+pad → Handset → CHARGE-pad → DC-pin of J1(-).

4.9. Block Diagram (Range Extender_Main)

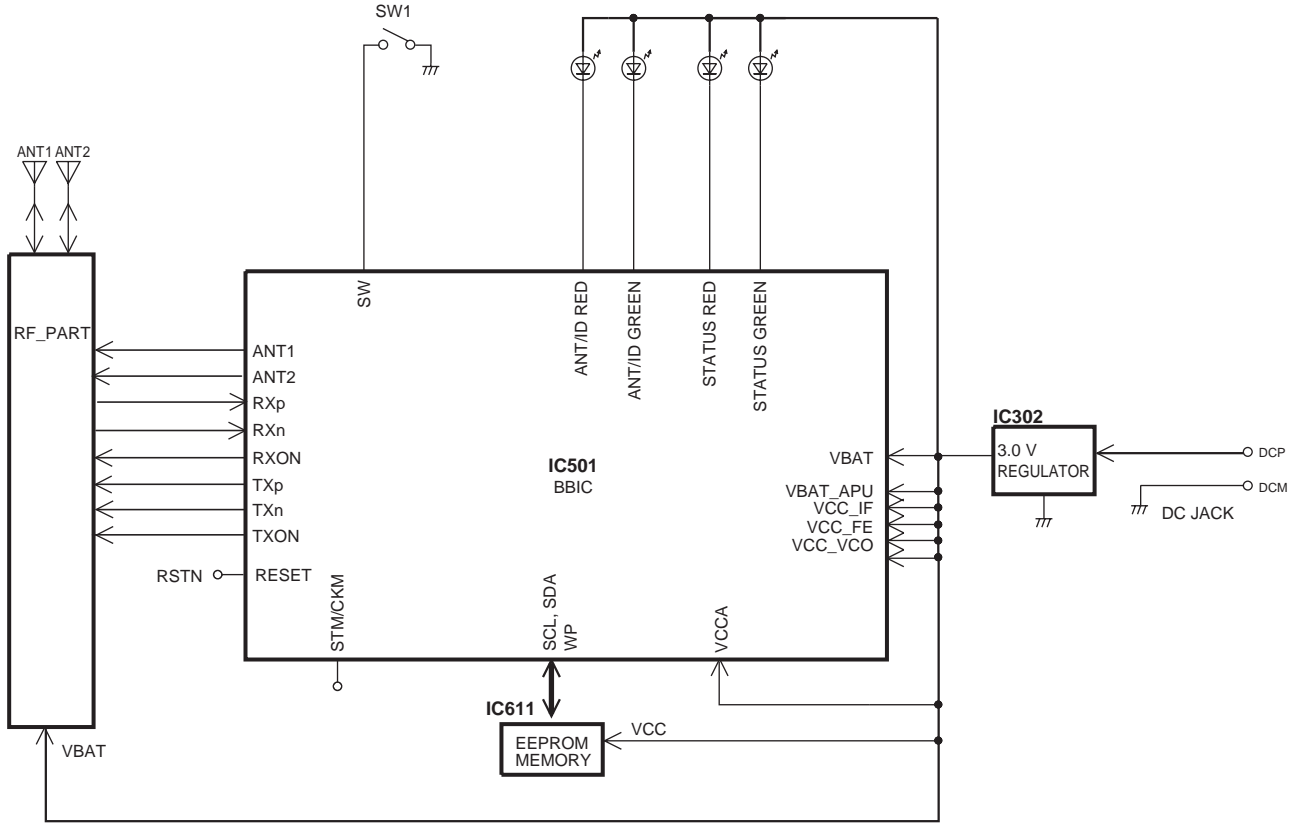

KX-TGA405 BLOCK DIAGRAM (Range Extender_Main)

4.10. Block Diagram (Range Extender_RF Part)

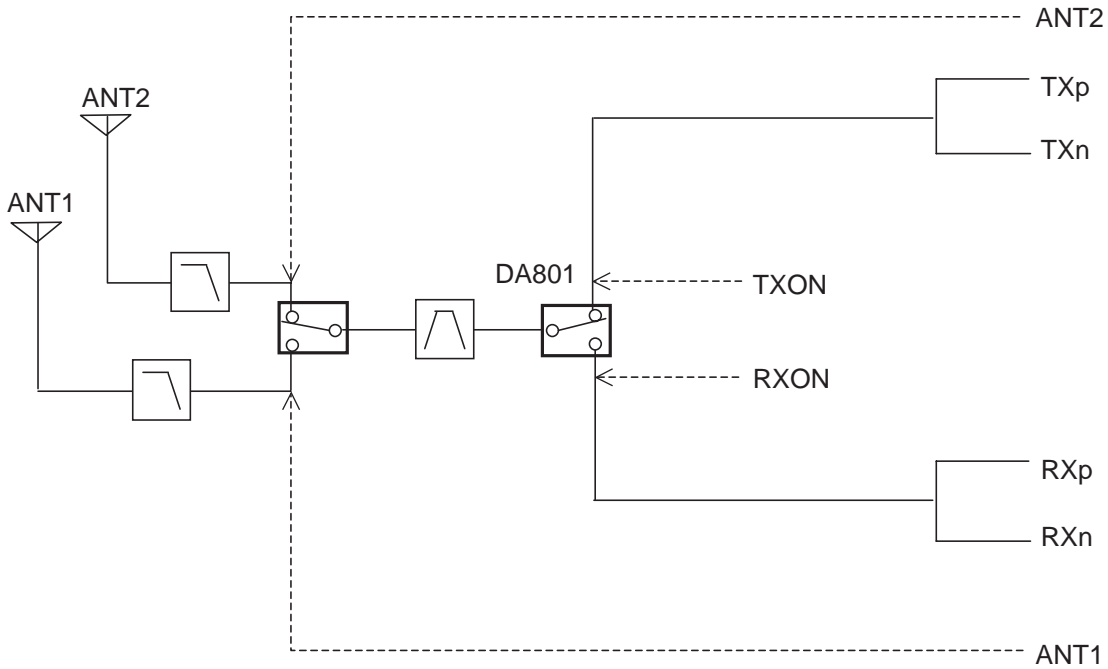

KX-TGA405 BLOCK DIAGRAM (Range Extender_RF Part)

4.11. Circuit Operation (Range Extender)

(BBIC, EEPROM) is a digital speech/signal processing system.

The BBIC system is fully controlled by a host processor.

The host processor provides activation and control of all that functions as follows.

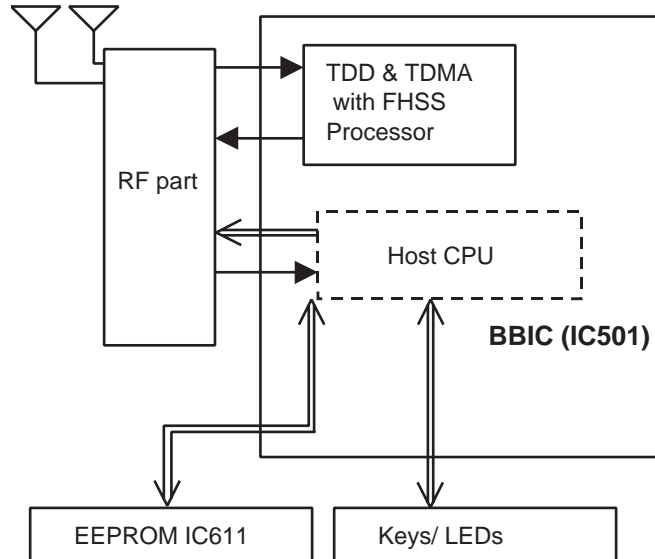

4.11.1. BBIC (Base Band IC: IC501)

- Block Interface Circuit
RF part, LED, Key scan

4.11.2. EEPROM (IC611)

Following information data is stored.

- Settings
ex: ID codes, parameters for adequate performance

4.11.3. Power Supply Circuit

The power supply voltage from AC adaptor is converted to VBAT (3.0 V) in IC302. VBAT is used for BBIC and all peripherals. Circuit Operation:

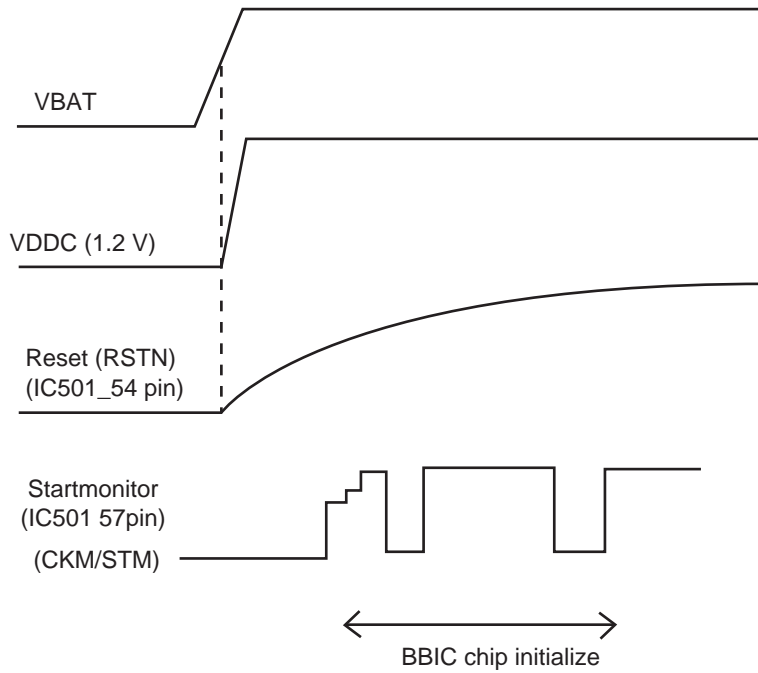
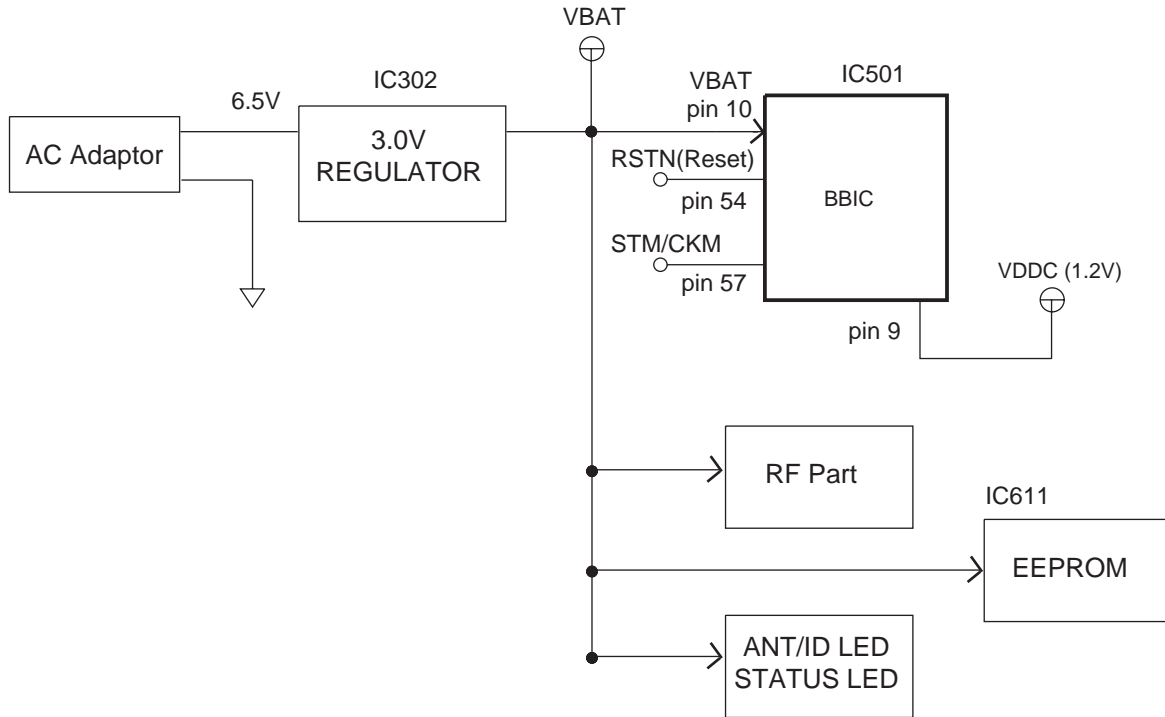

4.12. Signal Route

SIGNAL ROUTE	IN	ROUTE	OUT
HANDSET TX		HANDSET MIC - R73/74 - C11/13 - RA4 - IC1(22/23) - <HANDSET_RF_TX_ROUTE> - ANT. ---	
		---ANT. - <BASE_UNIT_RF_RX_ROUTE> - IC501(46/47 - 28) - C184 - Q161 - Q141 - D101 - L101/[L102 - P101] - T/R(TEL LINE)	
HANDSET RX		T/R(TEL LINE) - L101/[P101 - L102] - D101 - Q141 - R165 - R177 - C173 - Q171 - C178 - R178 - IC501(16 - 44/45) - <BASE_UNIT_RF_TX_ROUTE> - ANT. ---	
		--- ANT. - <HANDSET_RF_RX_ROUTE> - IC1(28/27) - C16 - L8 - HEADSET_JACK(5 - 4) - HANDSET SPEAKER	
HEADSET TX		HEADSET_JACK(2) - R80 - C14 - R22 - IC1(25) - <HANDSET_RF_TX_ROUTE> - ANT. ---	
		---ANT. - <BASE_UNIT_RF_RX_ROUTE> - IC501(46/47 - 28) - C184 - Q161 - Q141 - D101 - L101/[L102 - P101] - T/R(TEL LINE)	
HEADSET RX		T/R(TEL LINE) - L101/[P101 - L102] - D101 - Q141 - R165 - R177 - C173 - Q171 - C178 - R178 - IC501(16 - 44/45) - <BASE_UNIT_RF_TX_ROUTE> - ANT. ---	
		--- ANT. - <HANDSET_RF_RX_ROUTE> - IC1(28) - C16 - L8 - HEADSET_JACK(5)	
HANDSET SP-Phone TX		HANDSET MIC - R73/74 - C11/13 - RA4 - IC1(22/23) - <HANDSET_RF_TX_ROUTE> - ANT. ---	
		---ANT. - <BASE_UNIT_RF_RX_ROUTE> - IC501(46/47 - 28) - C184 - Q161 - Q141 - D101 - L101/[L102 - P101] - T/R(TEL LINE)	
HANDSET SP-Phone RX		T/R(TEL LINE) - L101/[P101 - L102] - D101 - Q141 - R165 - R177 - C173 - Q171 - C178 - R178 - IC501(16-44/45) - <BASE_UNIT_RF_TX_ROUTE> - ANT. ---	
		--- ANT. - <HANDSET_RF_RX_ROUTE> - IC1(29/31) - Backside SP	
BASE SP-Phone TX		MIC - C457/C458 - RA452 - IC501 (23/22 - 28) - C184 - Q161 - Q141 - D101 - L101/[L102 - P101] - T/R(TEL LINE)	
BASE SP-Phone RX		T/R(TEL LINE) - L101/[P101 - L102] - D101 - Q141 - R165 - R177 - C173 - Q171 - C178 - R178 - IC501 (16 - 29/31) - L474/L476 - SPEAKER	
INTERCOM HANDSET TO BASE UNIT		HANDSET MIC - R73/74 - C11/13 - RA4 - IC1(22/23) - <HANDSET_RF_TX_ROUTE> - ANT. ---	
		--- ANT. - <BASE_UNIT_RF_RX_ROUTE> - IC501(46/47 - 29/31) - L474/L476 - SPEAKER	
INTERCOM BASE UNIT TO HANDSET		MIC - C457/C458 - RA452 - IC501(23/22 - 44/45) - <BASE_UNIT_RF_TX_ROUTE> - ANT. ---	
		--- ANT. - <HANDSET_RF_RX_ROUTE> - IC1(28/27) - C16 - L8 - HEADSET_JACK(5 - 4) - R11 - HANDSET SPEAKER	
GREETING RECORDING		HANDSET MIC - R73/74 - C11/13 - RA4 - IC1(22/23) - <HANDSET_RF_TX_ROUTE> - ANT. ---	
		---ANT. - <BASE_UNIT_RF_RX_ROUTE> - IC501(46/47 - 73/74) - IC601	
GREETING PLAY TO TEL LINE		IC601 - IC501(73/74 - 28) - C184 - Q161 - Q141 - D101 - L101/[L102 - P101] - T/R(TEL LINE)	
ICM RECORDING		T/R(TEL LINE) - L101/[P101 - L102] - D101 - Q141 - R165 - R177 - C173 - Q171 - C178 - R178 - IC501(16 - 73/74) - IC601	
ICM PLAY TO SPEAKER		IC601 - IC501(73/74 - 29/31) - L474/L476 - SPEAKER	
DTMF SIGNAL TO TEL LINE		IC501(28) - C184 - Q161 - Q141 - D101 - L101/[L102 - P101] - T/R(TEL LINE)	
CALLER ID		T/R(TEL LINE) - L101/[P101 - L102] - C121/C122 - R121/R122 - IC501(24/25)	
BELL DETECTION		T/R(TEL LINE) - L101/[P101 - L102] - R111/R112 - C111/C112 - Q111 - IC501(59)	

Note:

: inside of Handset

RF part signal route

SIGNAL ROUTE	IN	→	ROUTE	→	OUT
HANDSET RF [TX_ROUTE]			IC1(44/45) - L809 - C812 - DA801 - C803 - C801 - ANT		
HANDSET RF [RX_ROUTE]			ANT - C801 - C803 - DA801 - C826 - IC1(46/47)		
BASE UNIT RF [TX_ROUTE]			IC501(44/45) - C812 - L809 - DA801 - C895 - DA802 - C894/C893 - ANT1/ANT2		
BASE UNIT RF [RX_ROUTE]			ANT1/ANT2 - C894/C893 - DA802 - C895 - DA801 - C826 - IC501(46/47)		

Note:

: inside of Handset

Range Extender signal route

SIGNAL ROUTE	IN	→	ROUTE	→	OUT
RANGE EXTENDER RF RX_TX_ROUTE			ANT1/ANT2 - C893/C894 - DA802 - C895 - DA801 - C826 - IC501 (46/47 - 44/45) - C812 - L809 - DA801 - C895 - DA802 - C893/C894 - ANT1/ANT2		

5 Location of Controls and Components

Refer to the Operating Instructions.

Note:

You can download and refer to the Operating Instructions (Instruction book) on TSN Server.

6 Installation Instructions

Refer to the Operating Instructions.

Note:

You can download and refer to the Operating Instructions (Instruction book) on TSN Server.

7 Operating Instructions

Refer to the Operating Instructions.

Note:

You can download and refer to the Operating Instructions (Instruction book) on TSN Server.

8 Test Mode

8.1. Engineering Mode

8.1.1. Base Unit

Important:

Make sure the address on LCD is correct when entering new data. Otherwise, you may ruin the unit.

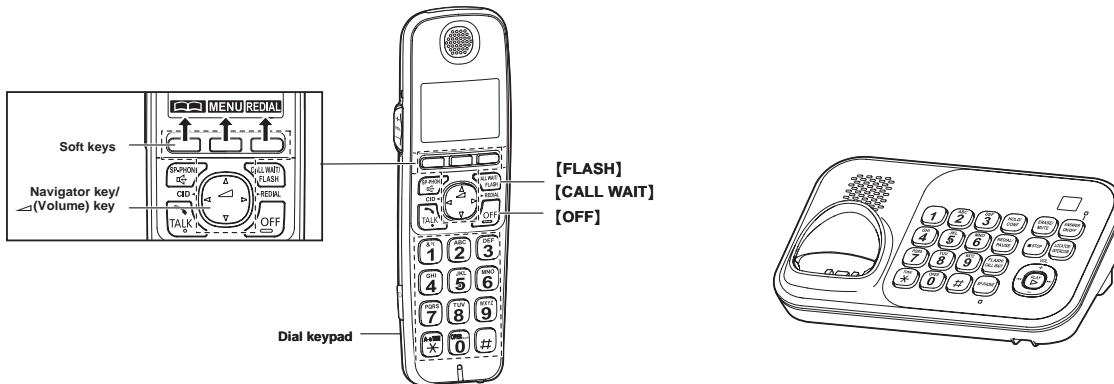

H/S key operation

- 1). Press **MENU** .
- 2). Select "Initial Setting" using **[▲]** or **[▼]** then press **SELECT** or **[▶]**.

Select "Set tel line" using **[▲]** or **[▼]** then press **SELECT** or **[▶]**.
- 3). Enter "7", "2", "6", "2", "7", "6", "6", "4".
Note: 7262 7664 = PANA SONI
(see letters printed on dial keys)
- 4). Select "Write EEP" using **[▲]** or **[▼]** then press **SELECT** or **[▶]**.
- 5). Enter "●", "●", "●", "●" (Address). (*1)
- 6). Enter "*", "*" (New Data). (*1)
- 7). Press **OK** , a long confirmation beep will be heard.
- 8). Press **[OFF]** to return to standby mode.
After that, turn the base unit power off and then power on.

Note: * To enter "Set dial mode", press **SELECT** or **[▶]** at "Set tel line". It is necessary to turn on the power of base unit.

H/S LCD

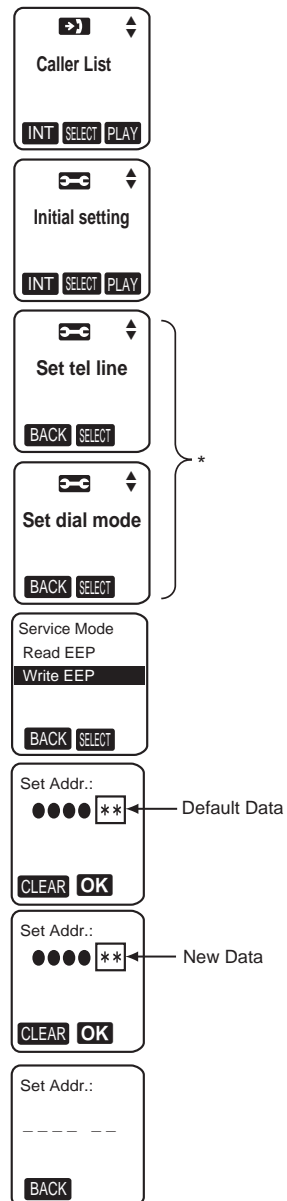

Frequently Used Items (Base Unit)

ex.)

Items	Address	Default Data	New Data		Remarks
Frequency	00 07 / 00 08	00/01	-	-	Use these items in a READ-ONLY mode to confirm the contents. Careless rewriting may cause serious damage to the computer system.
ID	00 02 ~ 00 06	Given value	-	-	

Note:

(*1) When you enter the address or New Data, please refer to the table below.

Desired Number (hex)	Input Keys	Desired Number (hex)	Input Keys
0	0	A	[Flash] + 0
1	1	B	[Flash] + 1
.	.	C	[Flash] + 2
.	.	D	[Flash] + 3
.	.	E	[Flash] + 4
9	9	F	[Flash] + 5

8.1.2. Handset

Important:

Make sure the address on LCD is correct when entering new data. Otherwise, you may ruin the unit.

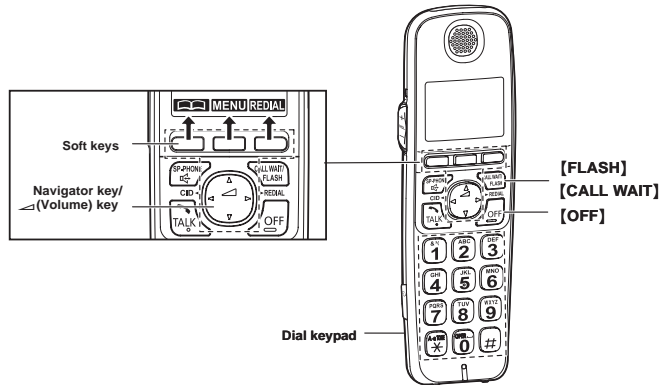

H/S key operation

- 1). Press **MENU** .
- 2). Select "Initial Setting" using **[▲]** or **[▼]** then press **SELECT** or **[▶]**.
- 3). Enter "7", "2", "6", "2", "7", "6", "6", "4".
Note: 7262 7664 = PANA SONI
(see letters printed on dial keys)
- 4). Select "Write EEP" using **[▲]** or **[▼]** then press **SELECT** or **[▶]**.
- 5). Enter "●", "●", "●", "●" (Address). (*1)
- 6). Enter " * ", " * " (New Data). (*1)
- 7). Press **OK** , a long confirmation beep will be heard.
- 8). Press **[OFF]** to return to standby mode.

H/S LCD

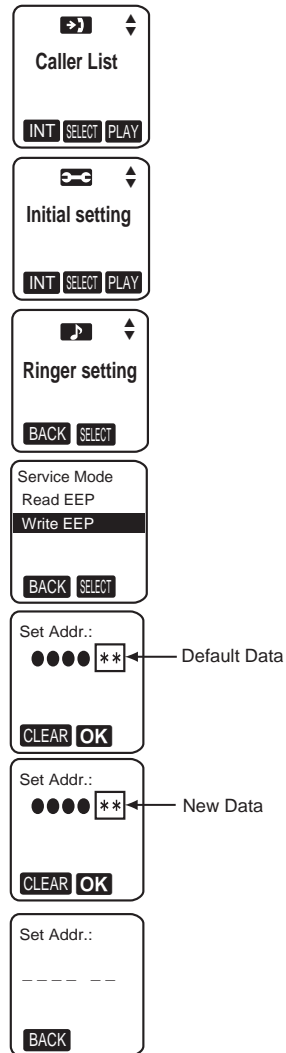

After that, remove and reinsert the batteries. Press the Power button for about 1 second if the power is not turned on.

Frequently Used Items (Handset)

ex.)

Items	Address	Default Data	New Data	Possible Adjusted Value MAX (hex)	Possible Adjusted Value MIN (hex)	Remarks
Battery Low	00 12/00 13	00 / 00	-	-	-	(*2)
Frequency	00 07 / 00 08	00 / 01	-	-	-	
ID	00 02 ~ 00 06	Given value	-	-	-	

Note:

(*1) When you enter the address or New Data, please refer to the table below.

Desired Number (hex.)	Input Keys	Desired Number (hex.)	Input Keys
0	0	A	[Flash] + 0
1	1	B	[Flash] + 1
.	.	C	[Flash] + 2
.	.	D	[Flash] + 3
.	.	E	[Flash] + 4
9	9	F	[Flash] + 5

(*2) Use these items in a READ-ONLY mode to confirm the contents. Careless rewriting may cause serious damage to the handset.

9 Service Mode

9.1. How to Clear User Setting (Handset Only)

Handset

Press **2**, **5**, **8**, **0** simultaneously until a beep sound is heard. Then single handset is initialized.
(The contents of user setting are reset to factory default)

*Usage time is not cleared.

10 Troubleshooting Guide

10.1. Troubleshooting Flowchart

10.1.1. Flow Chart (without Range Extender)

FLOW CHART

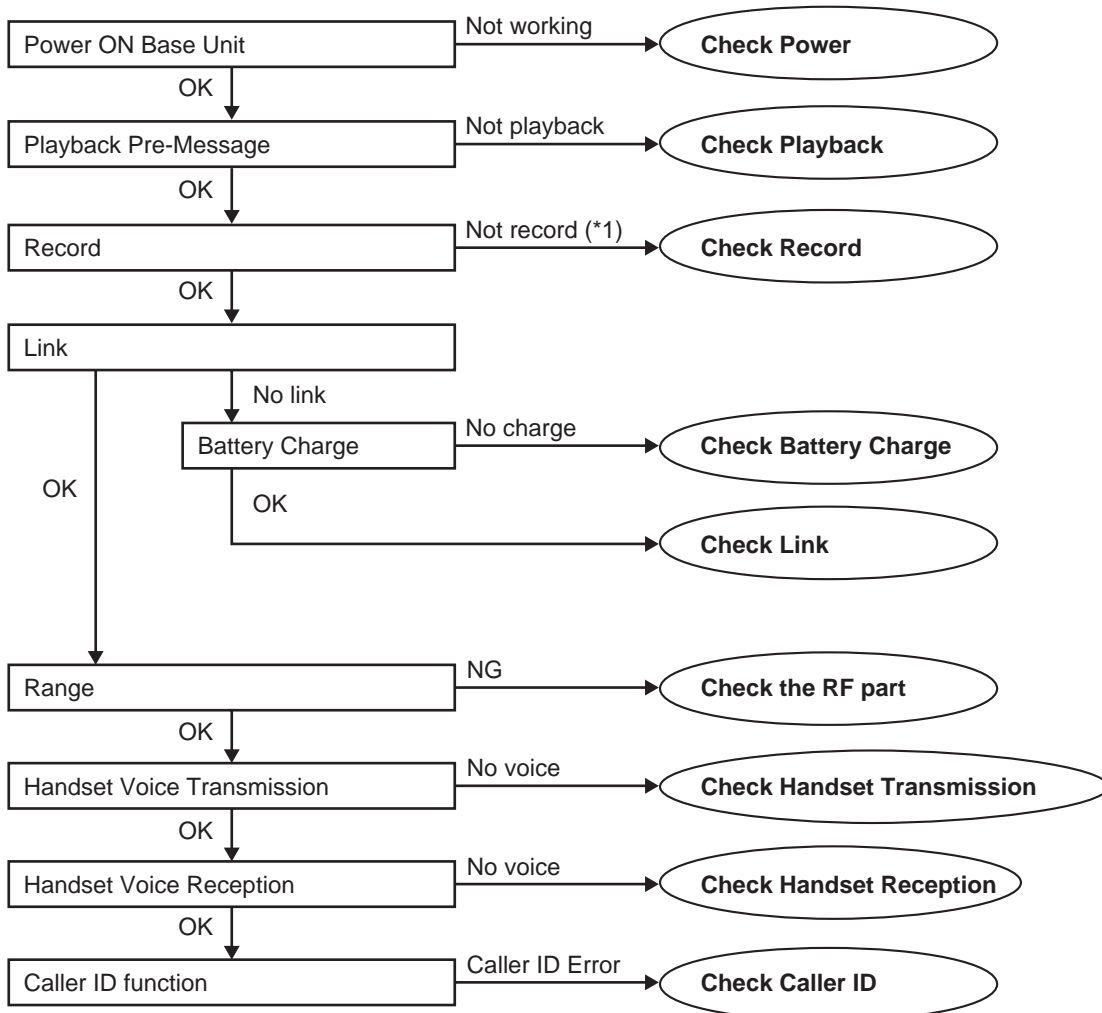

Cross Reference:

Check Power (P.34)

Check Playback (P.38)

Check Record (P.35)

Check Battery Charge (P.38)

Check Link (P.39)

Check the RF part (P.42)

Check Handset Transmission (P.47)

Check Handset Reception (P.47)

Check Caller ID (P.47)

Note:

(*1) When a user claims that the unit disconnects a call right after the greeting message and no incoming messages can be recorded, this symptom can not be reappeared with TEL simulator in the service center. In this case, try to change the Auto disconnect activation time and Vox level.

<How to change the Auto Disconnect activation time and VOX level> (P.36) item (A) and (B).

10.1.2. Flow Chart (Range Extender)

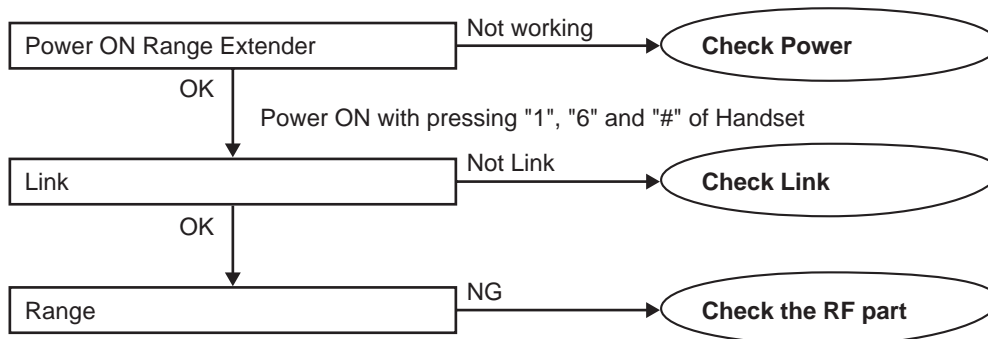

Cross Reference:
 Check Power (P.34)

Check Link (P.41)
 Check the RF part (P.42)

10.1.3. Check Power

10.1.3.1. Base Unit and Range Extender

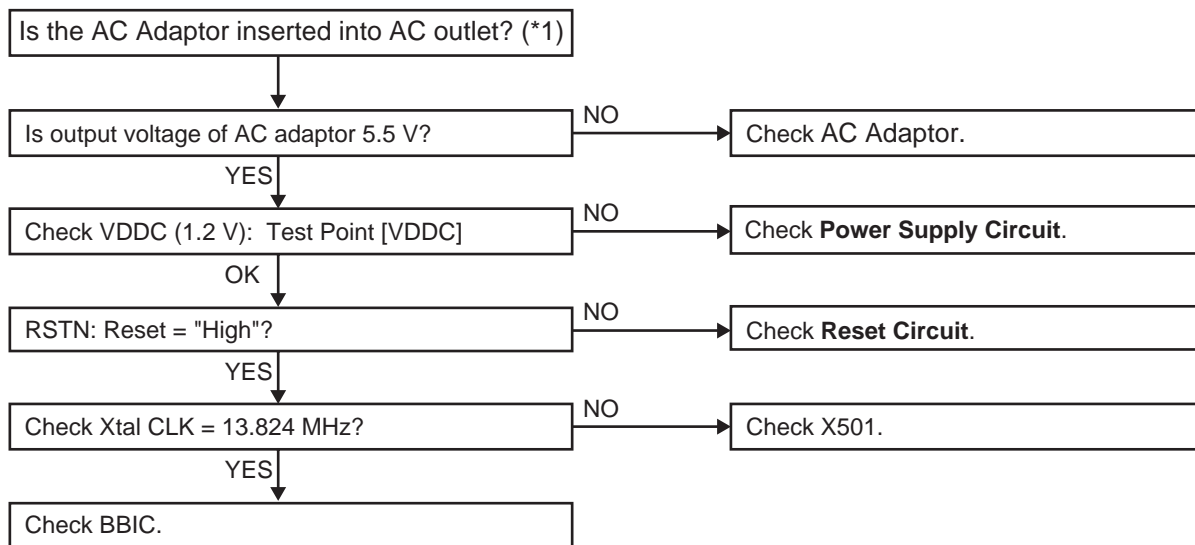

Cross Reference:
 Power Supply Circuit/Reset Circuit (P.12) for Base unit.
 Power Supply Circuit (P.24) for Range extender.
 Circuit Board (Base Unit_Main) (P.85).
 Circuit Board (Range Extender) (P.93).

Note:
 BBIC is IC501.
 (*1) Refer to **Specifications** (P.6) for part number and supply voltage of AC adaptor.
 (*2) Refer to **Circuit Board (Base Unit_Main)** (P.85).

10.1.3.2. Handset

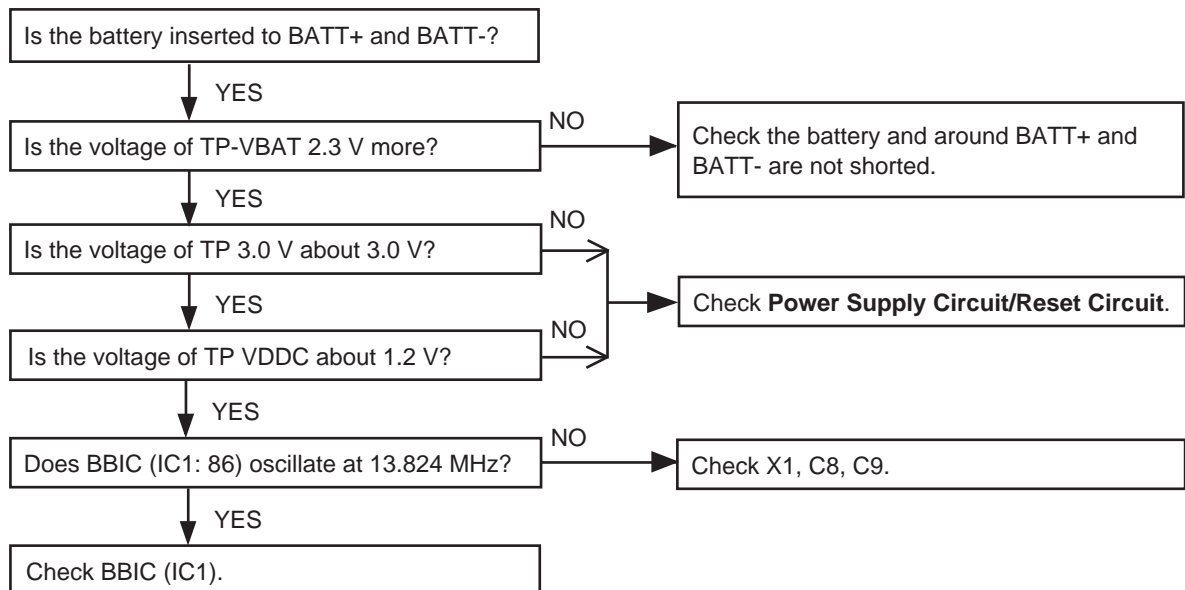

Cross Reference:

Power Supply Circuit/Reset Circuit (P.20)

10.1.4. Check Record

10.1.4.1. Base Unit

Not record Incoming Message

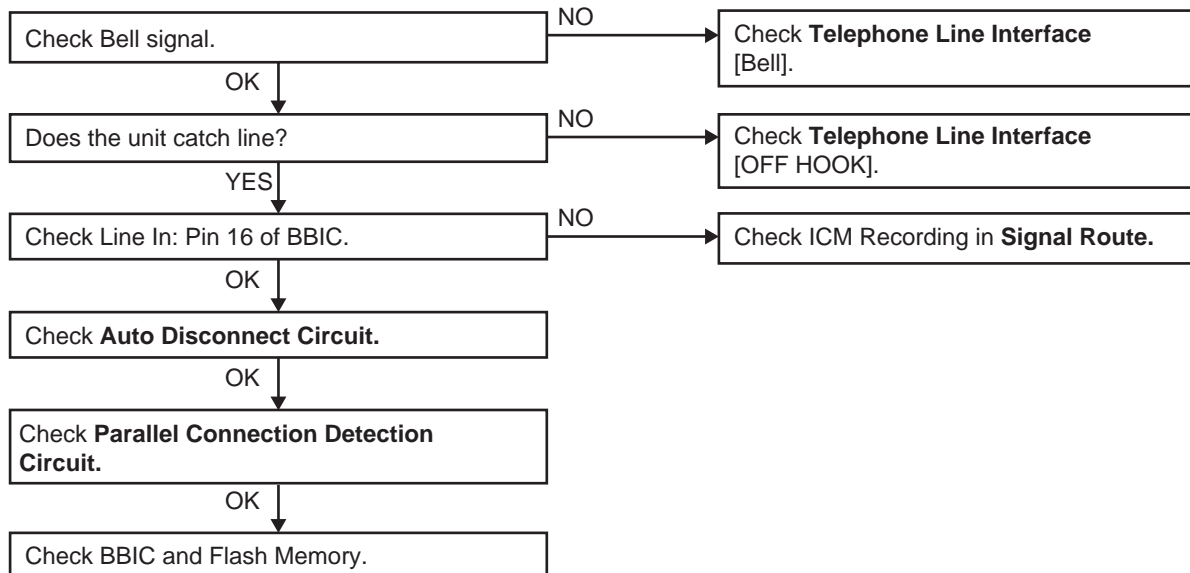

Cross Reference:

Signal Route (P.25)

Telephone Line Interface (P.14)

Parallel Connection Detect Circuit/Auto Disconnect Circuit (P.15)

Note:

Flash Memory is IC601.

BBIC is IC501.

<How to change the Auto Disconnect activation time and VOX level>

A) Auto Disconnect activation time:

Some Telephone Company lines (fiber or cable) ON Hook and OFF Hook voltages are lower than conventional lines, which may cause a malfunction of Auto Disconnect detection. To solve this problem, try changing the Auto Disconnect activation through the procedures below.

- 1) Press "MENU " key at standby Mode and "#" key.

Note: The set must power on and be linked.

- 2) Press "9", "0", "0", "0", "*" .

LCD (H/S)

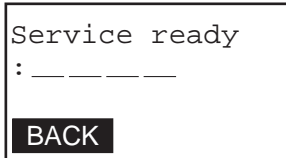

- 3) Press "7", "3", "1".

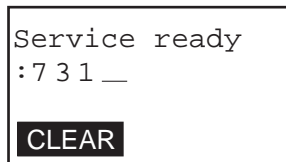

- 4) Then enter the below last digit;

last digit	"0"	Auto disconnect & CPC ^(*1) : enable . . . [default]
	"1"	Auto disconnect : enable ^(*1) CPC : disable
	"2"	Auto disconnect & CPC : disable ^(*2)

Note:

(*1) Both Auto Disconnect and CPC don't detect for the first 2 seconds.

(*2) If the "Disable" is selected, even if the parallel-connected telephone is OFF HOOK, the line isn't disconnected.

- 5) Back to "standby" mode automatically after step 4).
You can hear beep sound which is a confirmation tone.

B) Vox level:

It makes easier to detect a small voice (caller) by raising the sensitivity of VOX level. Therefore, the recording of TAM is not turned off during a detection.

1) ~ 2) are same as (A).

3) Press "5","1","1".

Service ready

:5 1 1 _

CLEAR

4) Then enter the below last digit;

last digit	"0"	default setting : normal
	"1"	6dB up

5) Back to "standby" mode automatically after step 4).
You can hear beep sound which is a confirmation tone.

10.1.5. Check Playback

10.1.5.1. Base Unit

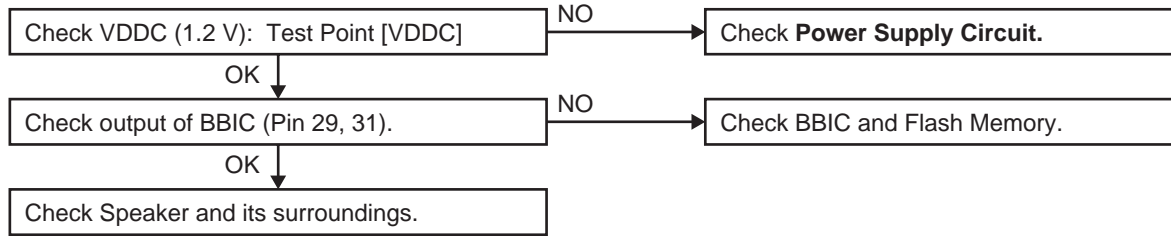

Cross Reference:
Power Supply Circuit/Reset Circuit (P.12)

Note:
 Flash Memory is IC601.
 BBIC is IC1.
 (*1) Refer to **Circuit Board (Base Unit_Main) (P.85)**.

10.1.6. Check Battery Charge

10.1.6.1. Base Unit

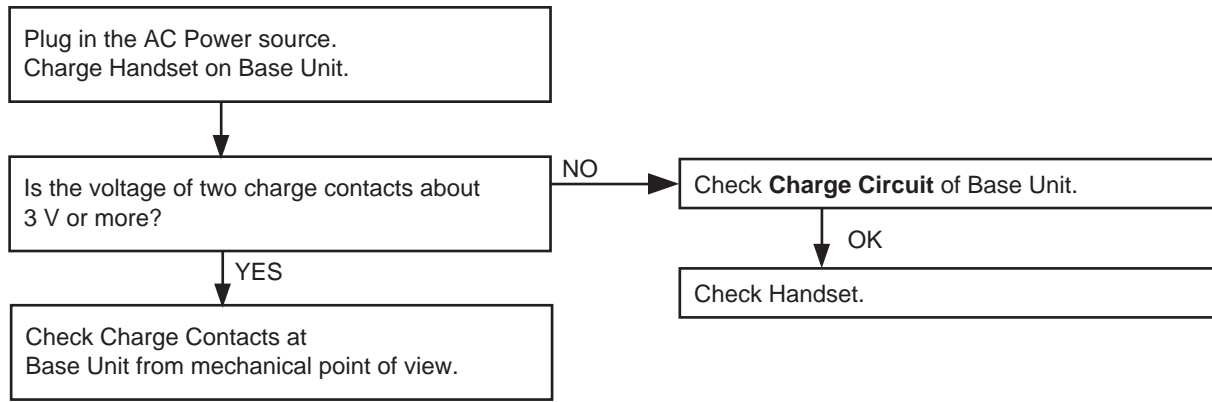

Cross Reference:
Charge Circuit (P.13)

10.1.6.2. Handset

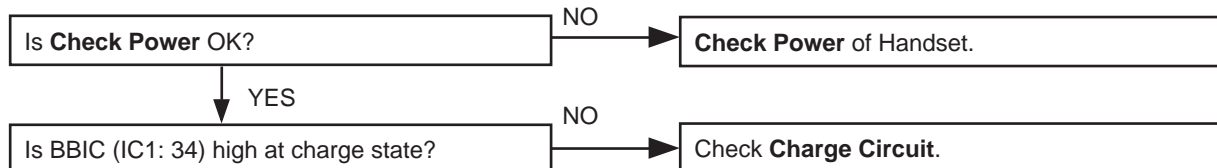

Cross Reference:
Check Power (P.34)
Charge Circuit (P.21)

10.1.6.3. Charger Unit

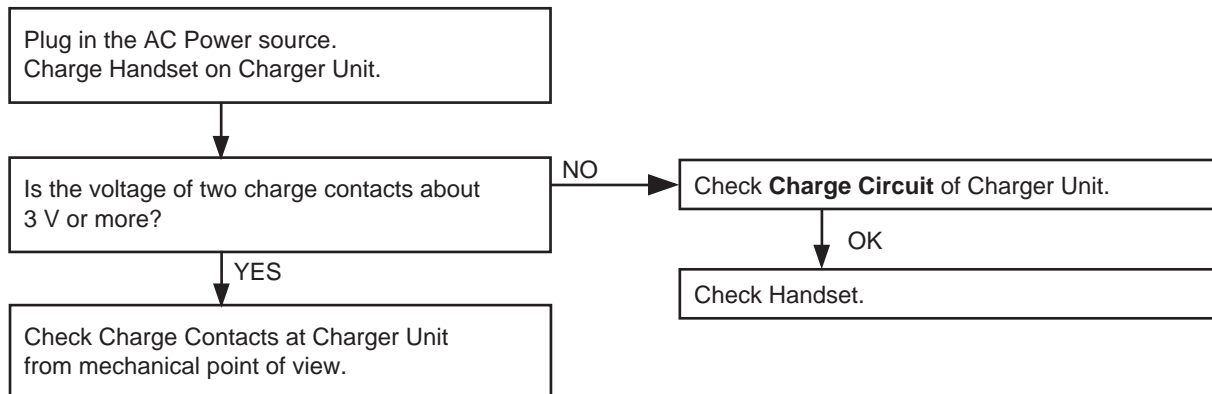

Cross Reference:
Charge Circuit (P.21)

10.1.7. Check Link

10.1.7.1. Base Unit

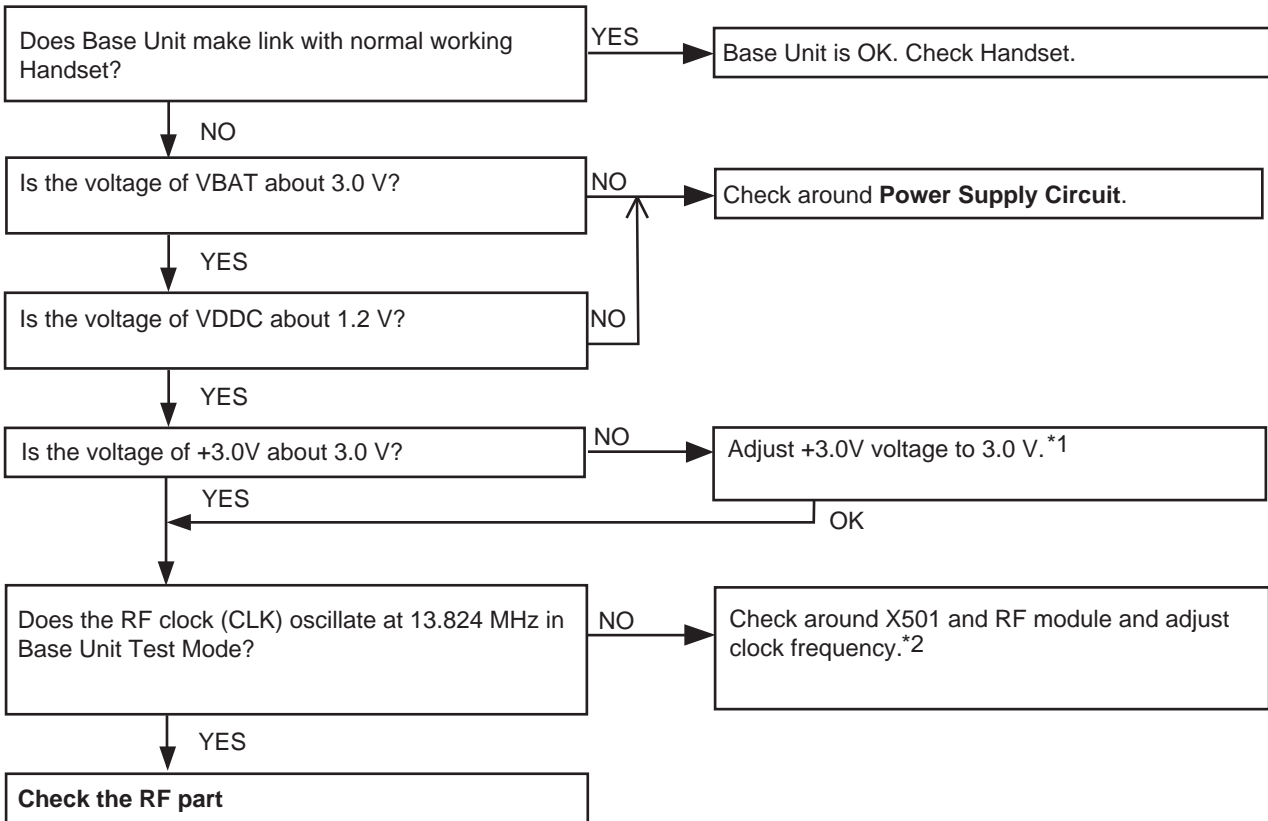

Cross Reference:

Power Supply Circuit/Reset Circuit (P.12)

Check the RF part (P.42)

Note:

*1 How to adjust +3.0V:

Execute the command "VDA"

Refer to **Things to Do after Replacing IC or X'tal (P.64)** for Base Unit.

*2 How to adjust the frequency of X501:

To see the frequency, execute the command "SFR", then check the TP_CKM (IC501-57pin).

To adjust frequency, send command "SFR □○○□○○" until the frequency counter becomes 13.824 MHz±55HZ.

10.1.7.2. Handset

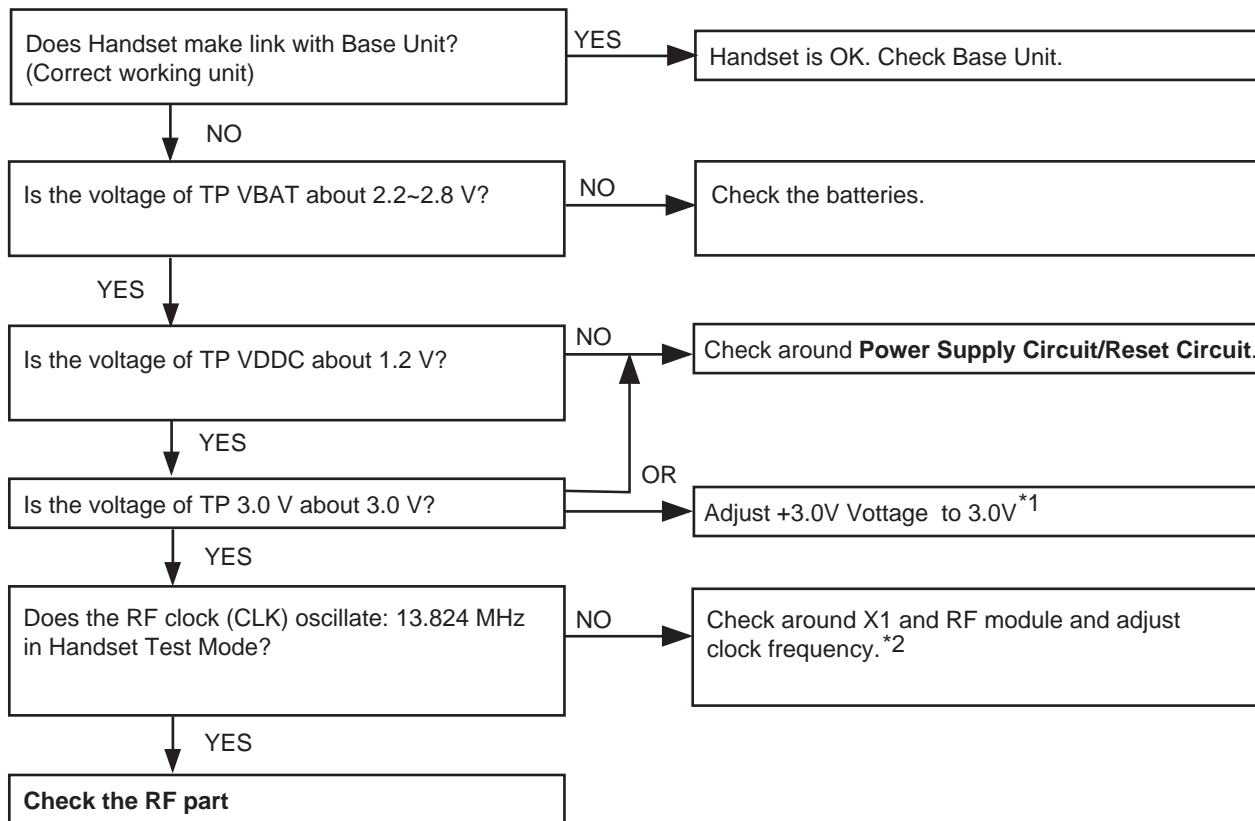

Cross Reference:

Power Supply Circuit/Reset Circuit (P.20)

Check the RF part (P.42)

Note:

*1 How to adjust +3.0V:

Execute the command "VDA"

Refer to **Things to Do after Replacing IC or X'tal** (P.65) for Handset.

*2 How to adjust the frequency of X1:

To see the frequency, execute the command "SFR", then check the TP_CKM (IC1-57pin).

To adjust frequency, send command "SFR □○○□○○" until the frequency counter becomes 13.824 MHz±55HZ.

10.1.7.3. Range Extender

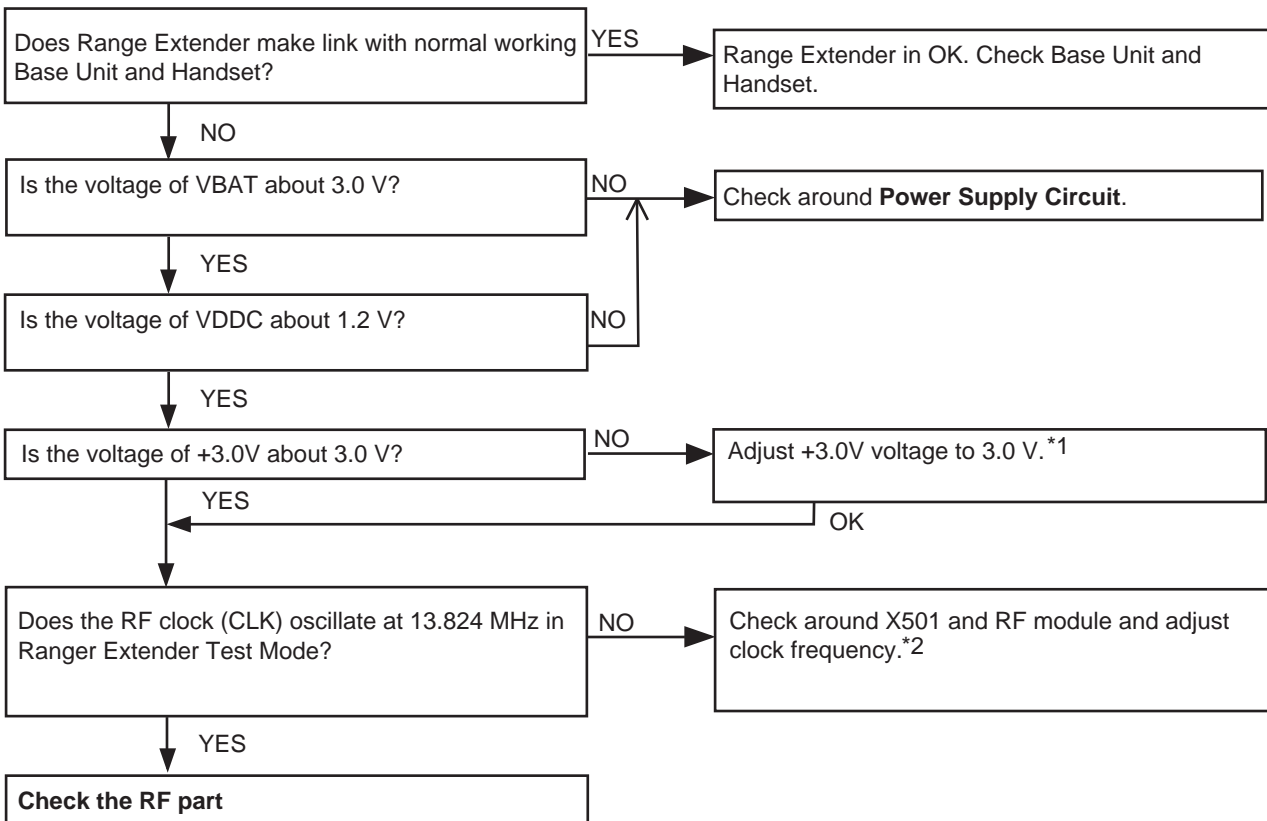

Cross Reference:

Power Supply Circuit (P.24)

Check the RF part (P.42)

Note:

*1 How to adjust +3.0V:

Execute the command "VDA"

Refer to **Things to Do after Replacing IC or X'tal** (P.65) for Range Extender.

*2 How to adjust the frequency of X501:

To see the frequency, execute the command "SFR", then check the TP_CKM (IC501-57pin).

To adjust frequency, send command "SFR □○○□○○" until the frequency counter becomes 13.824 MHz±55HZ.

10.1.8. Check the RF part

10.1.8.1. Finding out the Defective part

Prepare Regular HS (*1) and Regular BU (*2) and Regular RE (*3). Handset is Power ON with “1”, “6”and “#”.

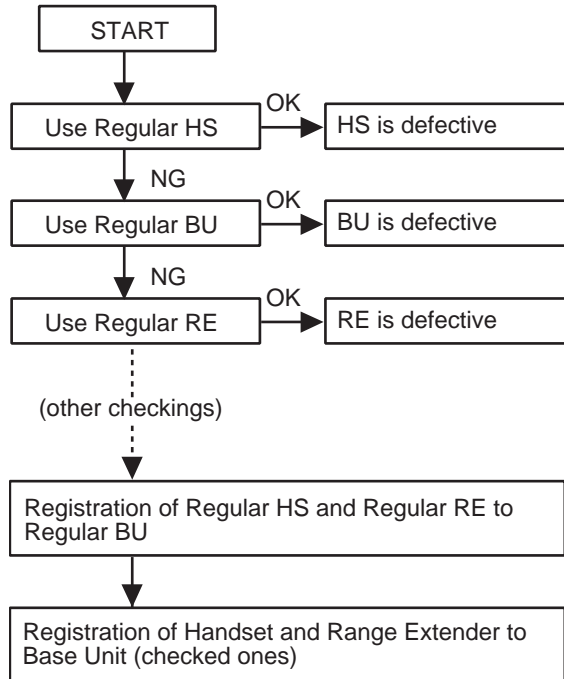

Note:

- (*1) HS: Handset
- (*2) BU: Base Unit
- (*3) RE: Range Extender

10.1.8.2. RF Check Flowchart

Each item (1 ~ 5) of RF Check Flowchart corresponds to **Check Table for RF part** (P.44).
Please refer to the each item.

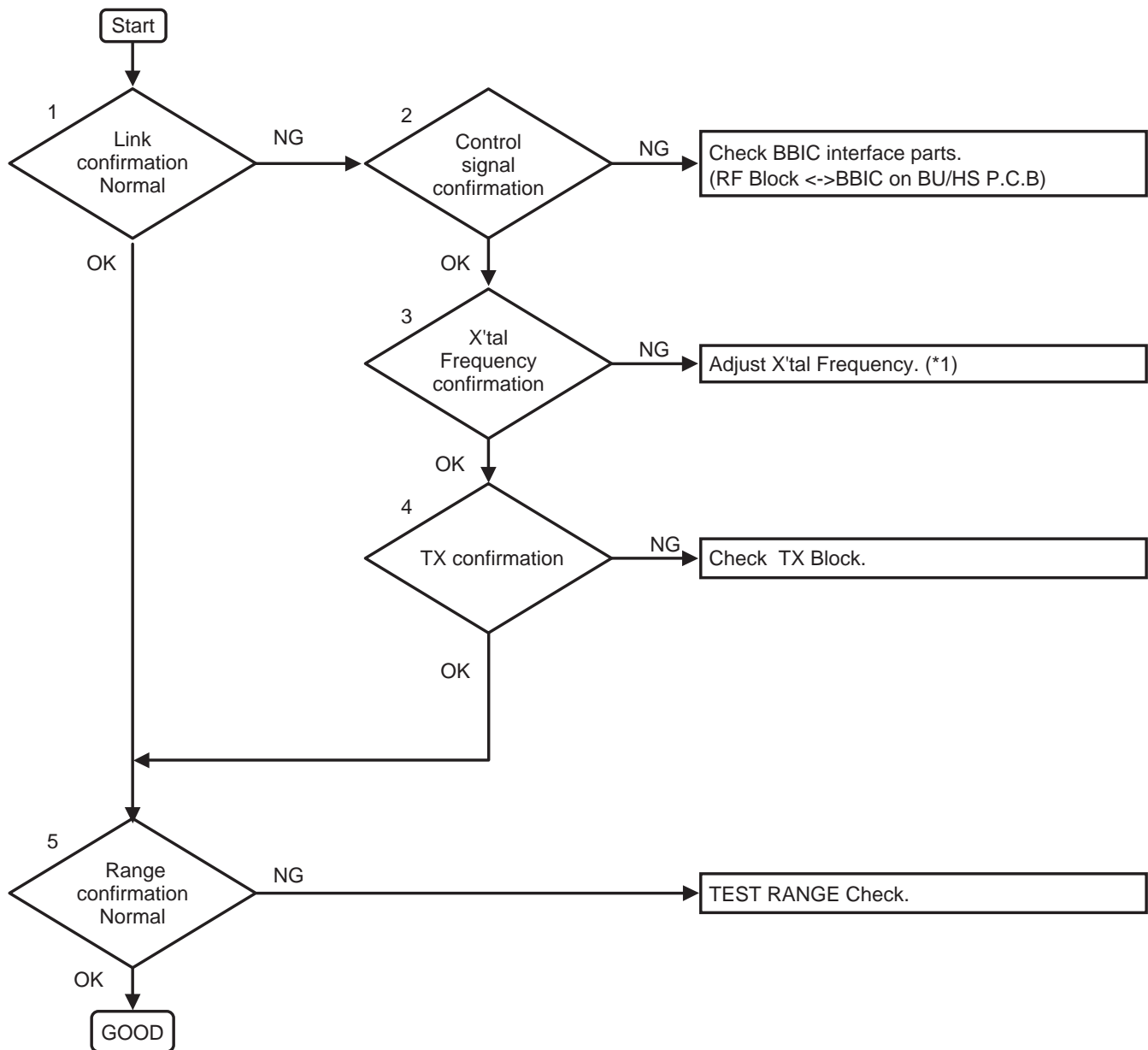

Note:

(*1) Refer to **Check Link** (P.39).

10.1.8.3. Check Table for RF part

No.	Item	BU (Base Unit) Check	HS (Handset) Check
1	Link Confirmation Normal HS, BU Mode [Normal Mode]	<ol style="list-style-type: none"> 1. Register Regular HS to BU (to be checked). 2. Press [Talk] key of the Regular HS to establish link. 	<ol style="list-style-type: none"> 1. Register HS (to be checked) to Regular BU. 2. Press [Talk] key of the HS to establish link.
2	X'tal Frequency confirmation HS, BU Mode: [Adjustment]	Check X'tal Frequency. (13.824000 MHz \pm 100 Hz)	Check X'tal Frequency. (13.824000 MHz \pm 100 Hz)
3	TX confirmation HS Mode: [HS_Burst Mode] (*1) BS Mode: [BS_Burst Mode] (*2)	<ol style="list-style-type: none"> 1. Remove wire antenna 2 and connect spectrum analyzer to TP. (*3) 2. Confirm TX power whether spec. is satisfied. Power \geq14.5dBm 	<ol style="list-style-type: none"> 1. Connect spectrum analyzer to TP.(*4) 2. Confirm TX power whether satisfied spec. Power \geq16.0dBm
4	Range Confirmation Normal HS, BU Mode: [Normal Mode]	<ol style="list-style-type: none"> 1. Register Regular HS to BU (to be checked). 2. Press [Talk] key of the Regular HS to establish link. 3. Compare the range of the BU (being checked) with that of the Regular BU. 	<ol style="list-style-type: none"> 1. Register HS (to be checked) to Regular BU. 2. Press [Talk] key of the HS to establish link. 3. Compare the range of the HS (being checked) with that of the Regular HS.

Note:

- (*1) Refer to **Commands (Handset)** (P.59)
- (*2) Refer to **Commands (Base Unit)** (P.59)
- (*3) **Adjustment Standard (Base Unit)** (P.60)
- (*4) **Adjustment Standard (Handset)** (P.63)

10.1.8.4. Check Table for Range Extender RF part

No.	Item	RE(Range Extender) Check
1	Link Confirmation HS Mode [Test Mode]	<ol style="list-style-type: none"> 1. Register Regular HS and RE (to be checked) to Regular BU. 2. HS is power ON with "1", "6"and "#". 3. Press [Talk] key of the Regular HS to establish link through RE.
2	X'tal Frequency confirmation RE Mode: [Adjustment]	Check X'tal Frequency. (13.824000 MHz \pm 100 Hz)
3	TX confirmation Regular HS Mode: [Test RX Mode] RE Mode: [Test TX_Burst Mode]	<ol style="list-style-type: none"> 1. Place Regular HS 15 cm away from a checked RE. 2. Confirm "TXDATA" waveform of RE (*1) and "RXDATA" waveform of Regular HS by Digital Oscilloscope.
4	RX confirmation Regular HS Mode: [Test TX_Burst Mode] RE Mode: [Test RX Mode]	<ol style="list-style-type: none"> 1. Place Regular HS 15 cm away from a checked RE. 2. Confirm "RXDATA" waveform of RE (*1) and "TXDATA" waveform of Regular HS by Digital Oscilloscope.
5	Range Confirmation Normal BU, RE Mode: [Normal Mode] HS Mode: Test mode	<ol style="list-style-type: none"> 1. Place Regular HS and RE (to be checked) to Regular BU. 2. HS is power ON with "1", "6"and "#". 3. Press [Talk] key of the Regular HS to establish link. 4. Compare the range of the RE (being checked) with that of the Regular RE

Note:

- (*1) **Adjustment Standard (Range Extender)** (P.62)

10.1.8.5. TEST RANGE Check

Circuit block which range is defective can be found by the following check.

Item	BU (Base Unit) Check	HS (Handset) Check
Range Confirmation TX TEST (TX Power check) HS, BU setting Checked unit: Low TX power (*1) Regular unit: High TX power (*1)	<ol style="list-style-type: none"> 1. Register Regular HS to BU (to be checked). 2. Set TX Power of the BU and the Regular HS according to CHART1. 3. At distance of about 20m between HS and BU, Link OK = TX Power of the BU is OK. No Link = TX Power of the BU is NG. 	<ol style="list-style-type: none"> 1. Register HS (to be checked) to Regular BU. 2. Set TX Power of the HS and the Regular BU according to CHART1. 3. At distance of about 20m between HS and BU, Link OK = TX Power of the HS is OK. No Link = TX Power of the HS is NG.
Range Confirmation RX TEST (RX sensitivity check) HS, BU setting Checked unit: High TX power (*1) Regular unit: Low TX power (*1)	<ol style="list-style-type: none"> 1. Register Regular HS to BU (to be checked). 2. Set TX Power of the BU and the Regular HS according to CHART1. 3. At distance of about 20m between HS and BU, Link OK= RX Sensitivity of the BU is OK. No Link = RX Sensitivity of the BU is NG. 	<ol style="list-style-type: none"> 1. Register HS (to be checked) to Regular BU. 2. Set TX Power of the Checking HS and the Regular BU according to CHART1. 3. At distance of about 20m between HS and BU, Link OK= RX Sensitivity of the HS is OK. No Link = RX Sensitivity of the HS is NG

CHART1: Setting of TX Power and RX Sensitivity in Range Confirmation TX TEST, RX TEST

	BU (to be checked)	Regular_HS
	TX Power	TX Power
BU (Base Unit) TX Power Check	Low	High
BU (Base Unit) RX Sensitivity Check	High	Low

	HS (to be checked)	Regular_BU
	TX Power	TX Power
HS (Handset) TX Power Check	Low	High
HS (Handset) RX Sensitivity Check	High	Low

Note:

(*1) Refer to **Commands (Base Unit)** (P.59).

10.1.8.6. TEST RANGE Check (Range Extender)

Item	RE (Range Extender) Check
Range Confirmation TX TEST (TX Power check) HS, setting Checked unit: Low TX power (*2) Regular unit: High TX power (*2)	<ol style="list-style-type: none"> 1. Register Regular HS and RE (to be checked) to Regular BU. 2. HS is power ON with "1", "6"and "#". 3. Set TX Power of the RE and the Regular HS according to CHART1. 4. At distance of about 20m between HS and RE, Link OK = TX Power of the RE is OK. No Link = TX Power of the RE is NG.
Range Confirmation RX TEST (RX sensitivity check) HS, BU setting Checked unit: High TX power (*2) Regular unit: Low TX power (*2)	<ol style="list-style-type: none"> 1. Register Regular HS and RE (to be checked) to Regular BU. 2. HS is power ON with "1", "6"and "#". 3. Set TX Power of the RE and the Regular HS according to CHART1. 4. At distance of about 15cm between BU and RE, 5. At distance of about 20m between HS and RE, Link OK= RX Sensitivity of the RE is OK. No Link = RX Sensitivity of the RE is NG.

CHART1: Setting of TX Power and RX Sensitivity in Range Confirmation TX TEST, RX TEST

	RE (to be checked)
	TX Power
RE(Range Extender) TX Power Check	Low
RE(Range Extender) RX Sensitivity Check	High

Note:

(*2) Refer to **Commands (Base Unit)** (P.59)

10.1.9. Registering a Handset to the Base Unit

The supplied handset and base unit are pre-registered. If for some reason the handset is not registered to the base unit, re-register the handset.

- 1 **Handset:**
[MENU] → **# 1 3 0**
- 2 **Base unit:**
 Press and hold **[LOCATOR]** for about 5 seconds until the registration tone sounds.
 - If all registered handsets start ringing, press **[LOCATOR]** again to stop, then repeat this step.
 - The next step must be completed within 90 seconds.
- 3 **Handset:**
 Press **[OK]**, then wait until a long beep sounds.

Note:

- While registering, “**Base in registering**” is displayed on all registered handsets.
- When you purchase an additional handset, refer to the additional handset’s installation manual for registration.

10.1.10. Deregistering a Handset

A handset can cancel its own registration to the base unit, or other handsets registered to the same base unit. This allows the handset to end its wireless connection with the system.

- 1 **[MENU]** → **# 1 3 1**
 - All handsets registered to the base unit are displayed.
- 2 **[↕]**: Select the handset you want to cancel. → **[SELECT]**
- 3 **[↕]**: “**Yes**” → **[SELECT]**
- 4 **[OFF]**

10.1.11. Deregistering a Range Extender

- 1 Power ON with pressing “PROGRAM” key.
- 2 Keep to press “PROGRAM” key for 10 seconds.
- 3 Amber LED is blinking and range extender move to auto registration mode.

10.1.12. Check Handset Transmission

Check MIC of handset.



Check handset Tx in **Signal Route**.

Cross Reference:
Signal Route (P.25)

10.1.13. Check Handset Reception

Check speaker of handset.



Check handset Rx in **Signal Route**.

Cross Reference:
Signal Route (P.25)

Note:
When checking the RF part, Refer to **Check the RF part** (P.42).

10.1.14. Check Caller ID

BASE UNIT

Did bell ring?
(Message indicator
blinks)

NO

Check bell signal detection in
Telephone Line Interface.

YES

Check **Calling Line Identification (Caller ID)/
Call Waiting Caller ID**.

Cross Reference:
Telephone Line Interface (P.14)
**Calling Line Identification (Caller ID)/Call Waiting Caller
ID** (P.16)

Note:

- Make sure the format of the Caller ID service of the Telephone company that the customer subscribes to.
- It is also recommended to confirm that the customer is really a subscriber of the service.

11 Disassembly and Assembly Instructions

11.1. Disassembly Instructions

11.1.1. Base Unit

- ① Remove the 5 screws to remove the cabinet cover.
- ② Remove the solders.

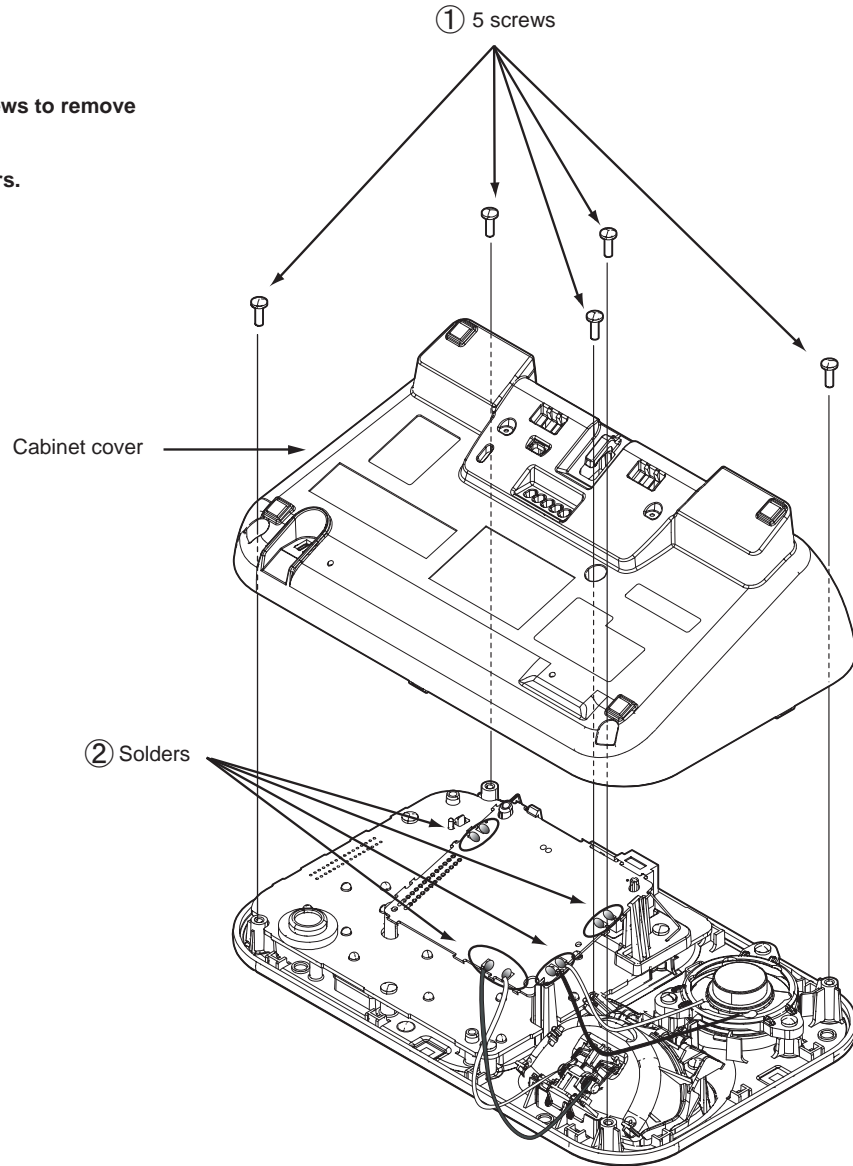

- ③ Remove the parrell wire to remove the main P.C. board.

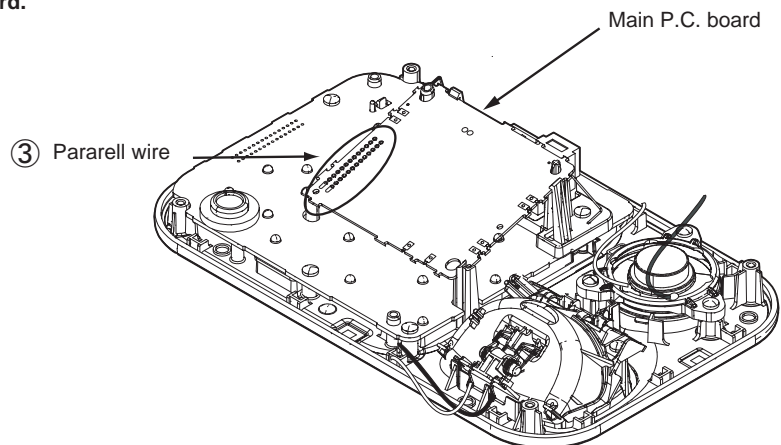

- ④ Remove the 2 screws to remove the Jack holder.

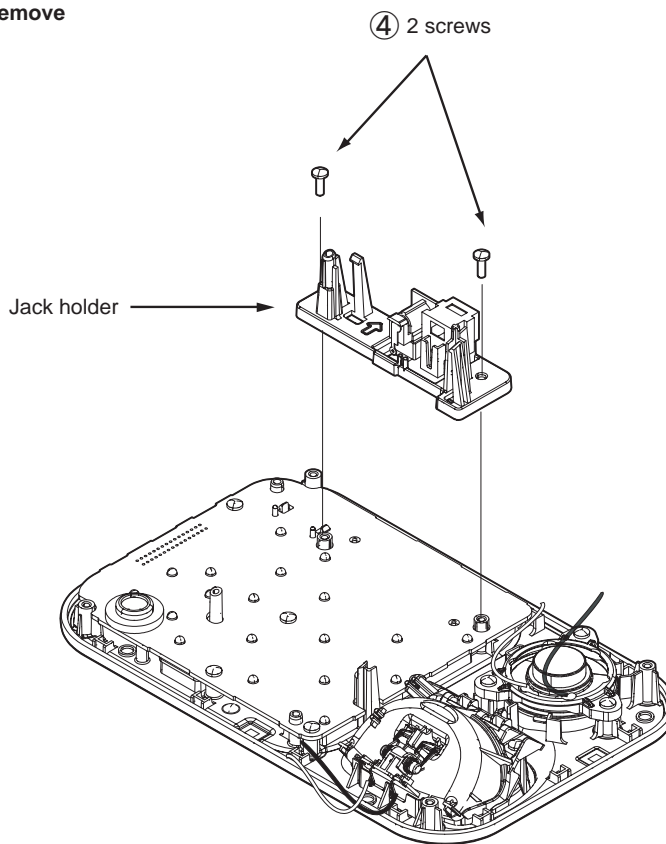

- ⑤ Remove the 4 screws to remove the operational P.C.B board.

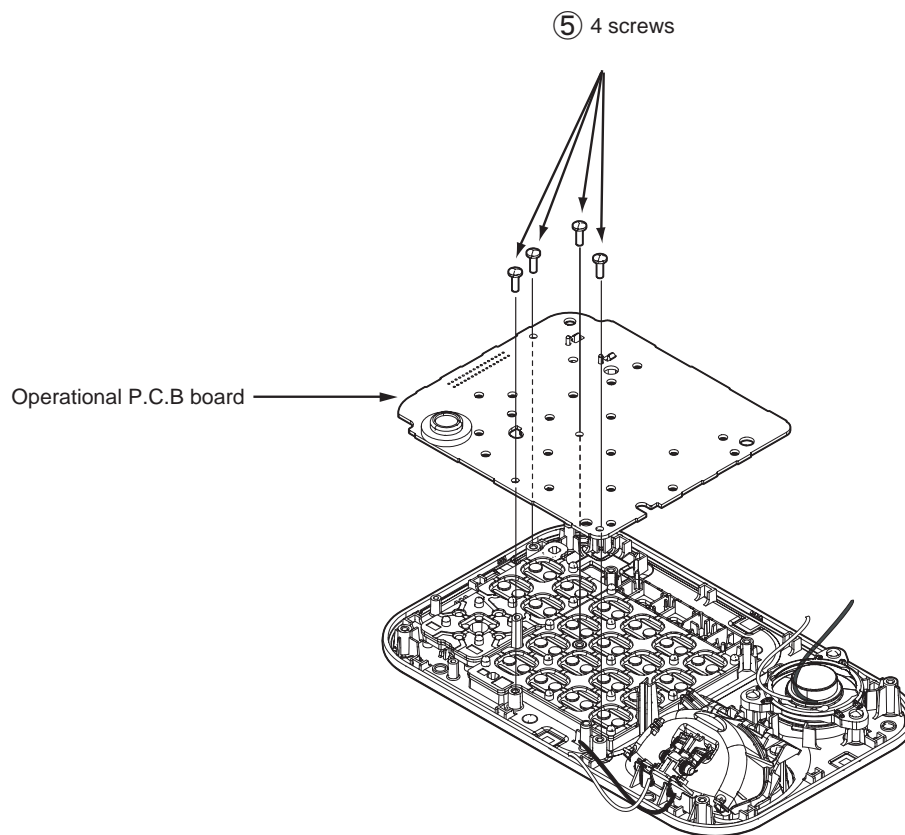

11.1.2. Handset

- ① Remove the 2 screws.

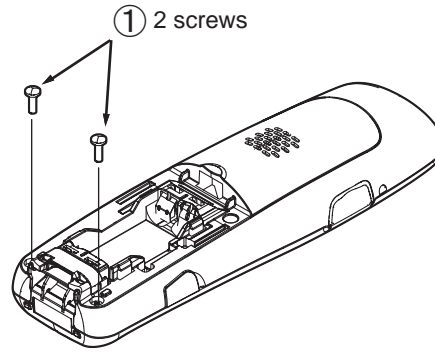

- ② Insert a plastic card. (Ex. Used SIM card etc.) between the cabinet body and the cabinet cover, then pull it along the gap to open the cabinet.

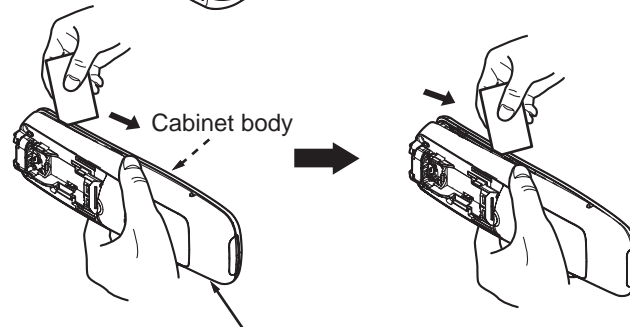

- ③ Likewise, open the other side of the cabinet.

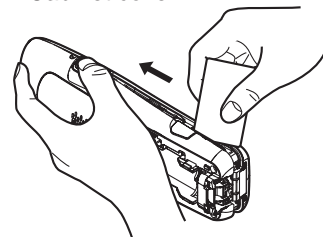

- ④ Remove the cabinet cover by pushing it upward.

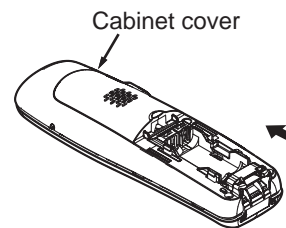

- ⑤ Remove the solders and tape.

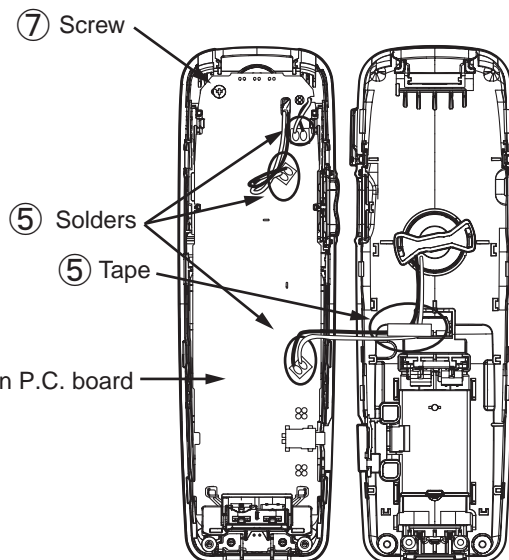

- ⑥ Remove the 2 screws to remove the 2 charge terminals.

- ⑦ Remove the screw to remove the main P. C. board.

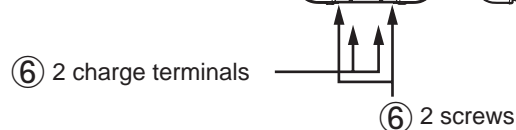

11.1.3. Charger Unit

① Remove the screw to remove the cabinet cover.

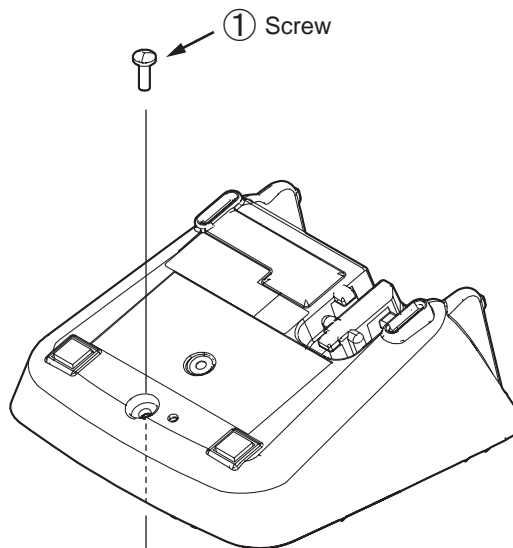

② Remove the solders to remove the 2 charge terminals.

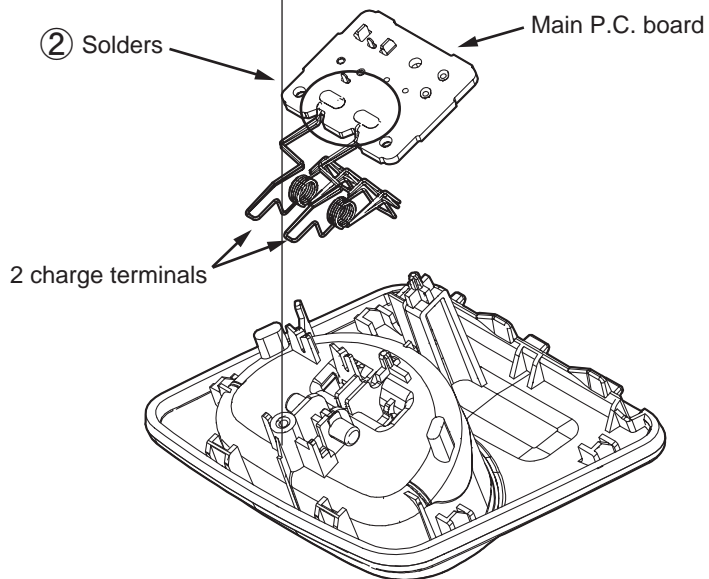

11.1.4. Range Extender

- ① Remove the 2 screws to remove the cabinet cover.

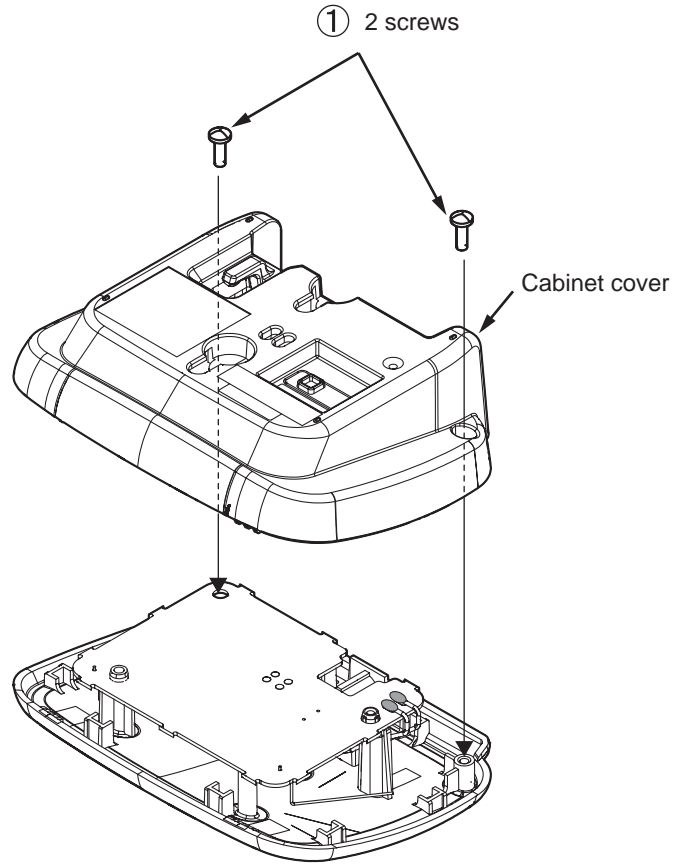

- ② Remove the solders to remove the main P.C. board.

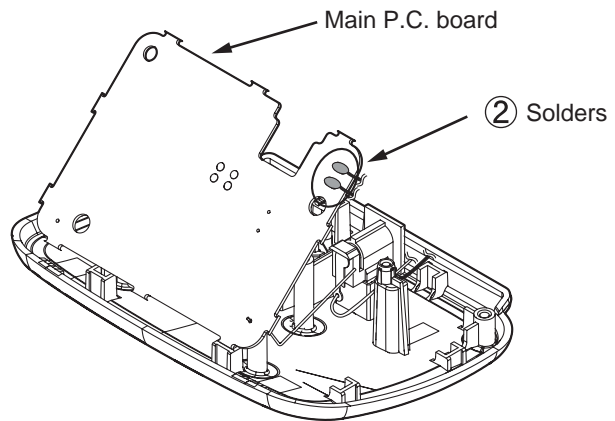

11.2. How to Replace the Base Unit LCD

- ① Fit the heatseal of a new LCD.

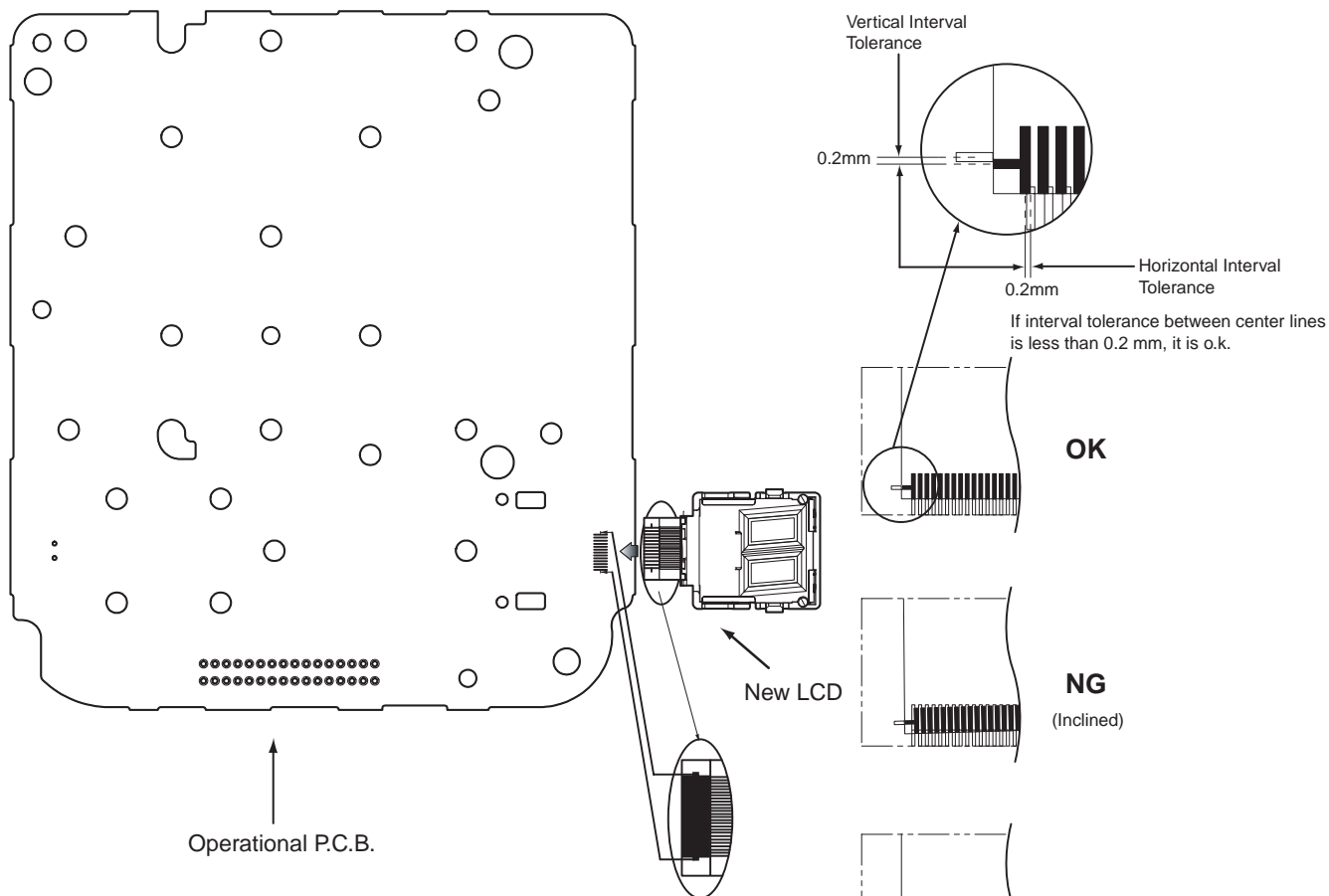

- ② Heatweld with the tip of the soldering iron about 5 to 8 seconds (in case of 60W soldering iron).

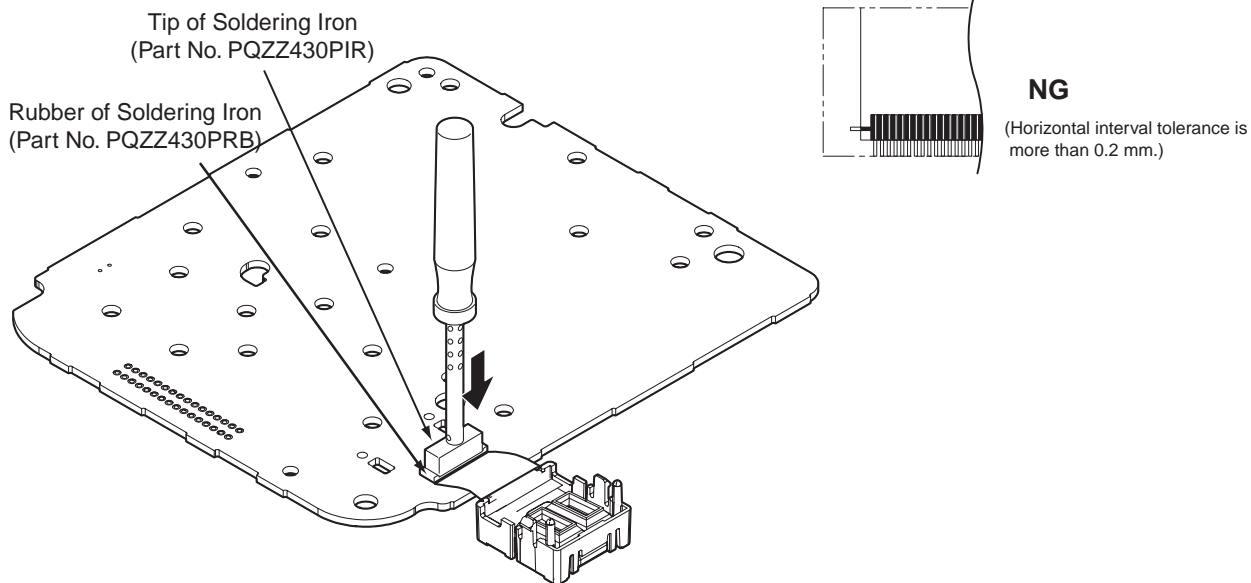

③ Attach the LCD and fix by hook A (two points).

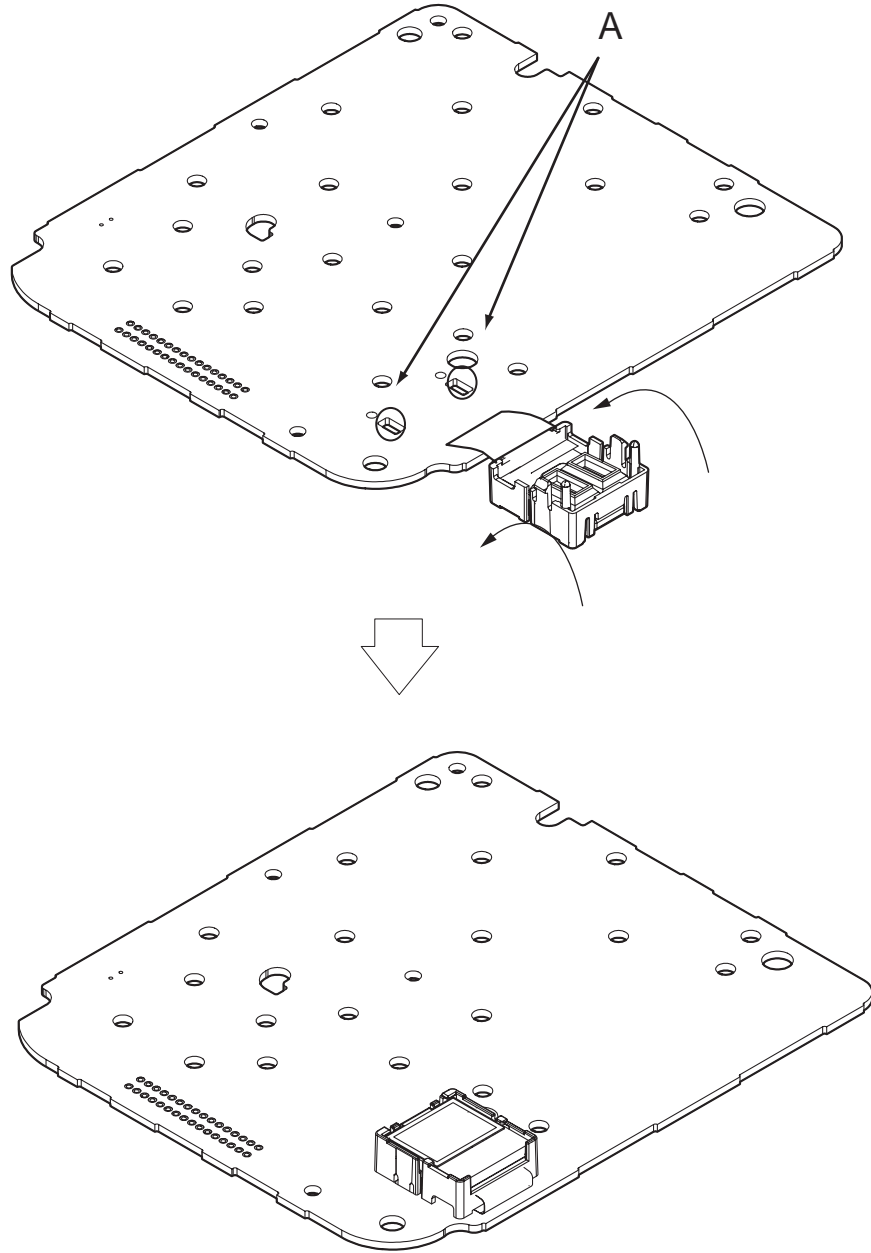

11.3. How to Replace the Handset LCD

Note:

The illustrations are simplified in this page.
They may differ from the actual product.

①

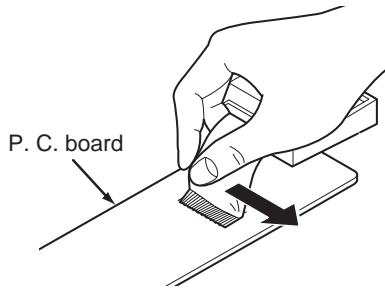

Peel off the FFC (Flexible Flat Cable) from the LCD, in the direction of the arrow. Take care to ensure that the foil on the P.C. board is not damaged.

②

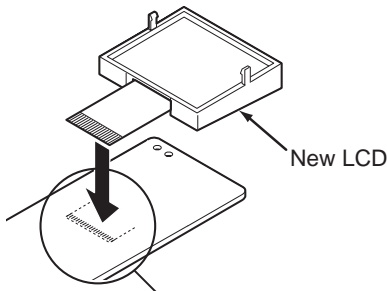

Fit the heatseal of a new LCD.

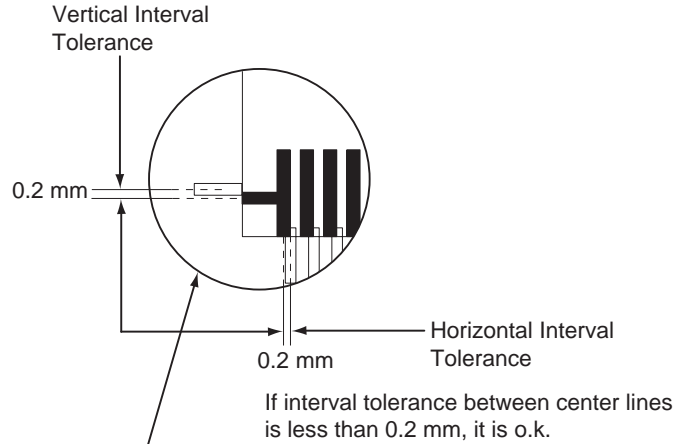

③

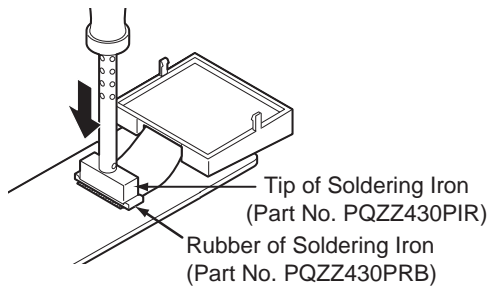

Heatweld with the tip of the soldering iron about 5 to 8 seconds (in case of 60W soldering iron).

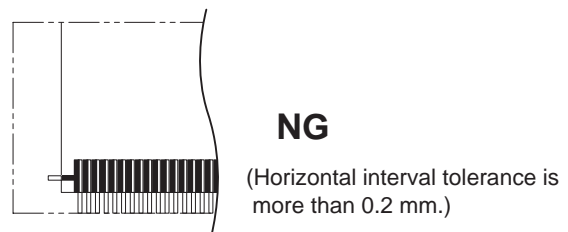
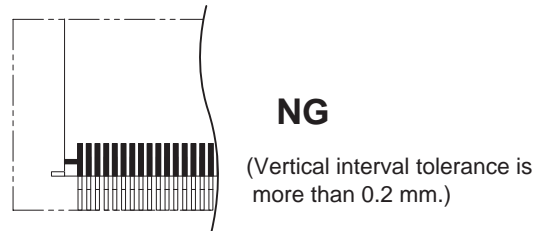
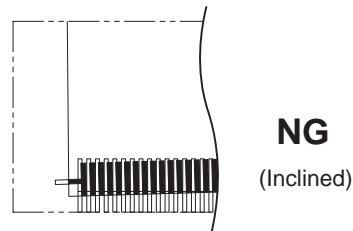

12 Measurements and Adjustments

This chapter explains the measuring equipment, the JIG connection, and the PC setting method necessary for the measurement in **Troubleshooting Guide** (P.33)

12.1. Equipment Required

- Digital multi-meter (DMM): it must be able to measure voltage and current.
- Oscilloscope.
- Frequency counter: It must be precise enough to measure intervals of 1 Hz (precision; ± 4 ppm)
Hewlett Packard, 53131A is recommended.
- DECT tester: Rohde & Schwarz, CMD 60 is recommended.
This equipment may be useful in order to precisely adjust like a mass production.

12.2. The Setting Method of JIG

<Preparation>

- Serial JIG cable: PQZZ1CD300E*
- PC which runs in DOS mode
- **Batch file CD-ROM** for setting: PNZZTG4741M

Note:

*: If you have the JIG Cable for TCD500 series (PQZZ1CD505E), change the following values of resistance. Then you can use it as a JIG Cable for both TCD300 and TCD500 series. (It is an upper compatible JIG Cable.)

Resistor	Old value (k Ω)	New value (k Ω)
R2	22	3.3
R3	22	3.3
R4	22	4.7
R7	4.7	10

12.2.1. Connections (Base Unit)

- ① Connect the AC adaptor.
- ② Connect the JIG Cable GND (black).
- ③ Connect the JIG Cable RX (red) and TX (yellow).

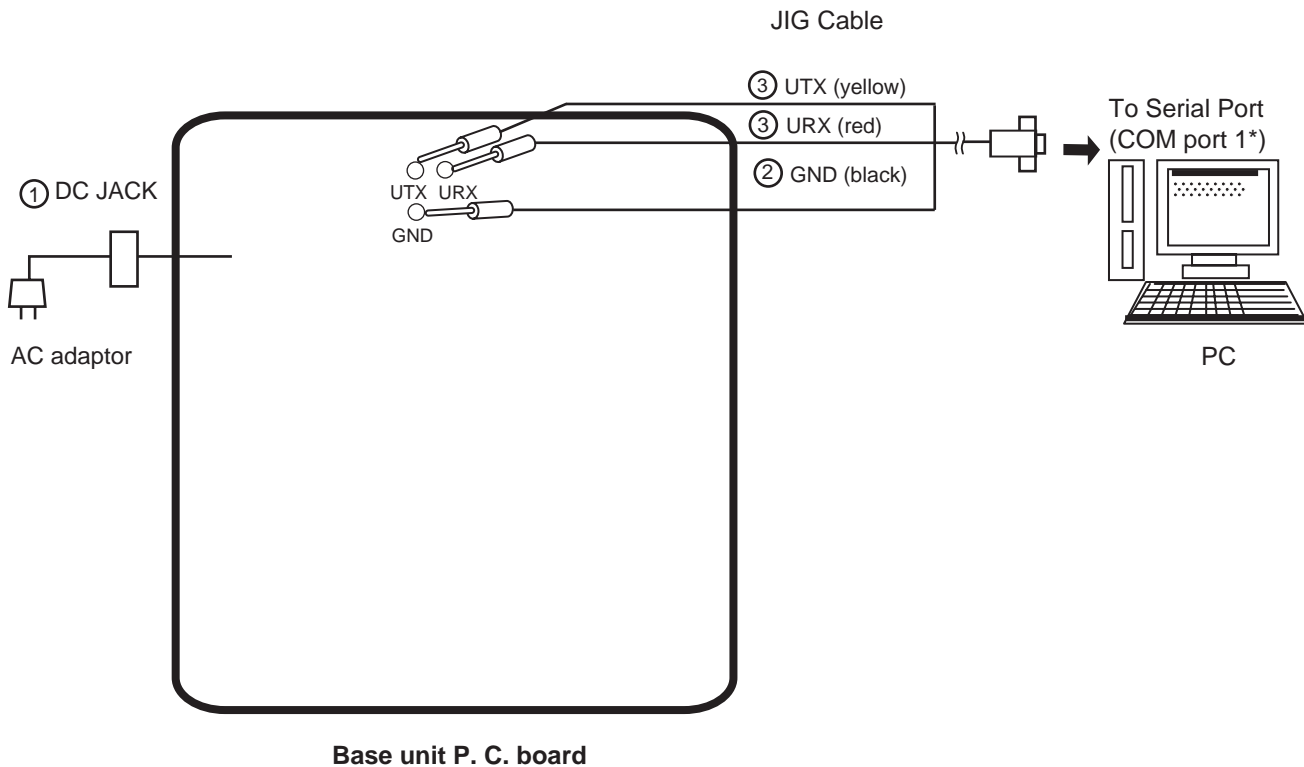

Note:

*: COM port names may vary depending on what your PC calls it.

12.2.2. Connections (Handset)

- ① Connect the DC Power or Battery to BATT+ and BATT-.
- ② Connect the JIG cable GND (black) to GND.
- ③ Connect the JIG cable UTX (yellow) to UTX and URX (red) to URX.

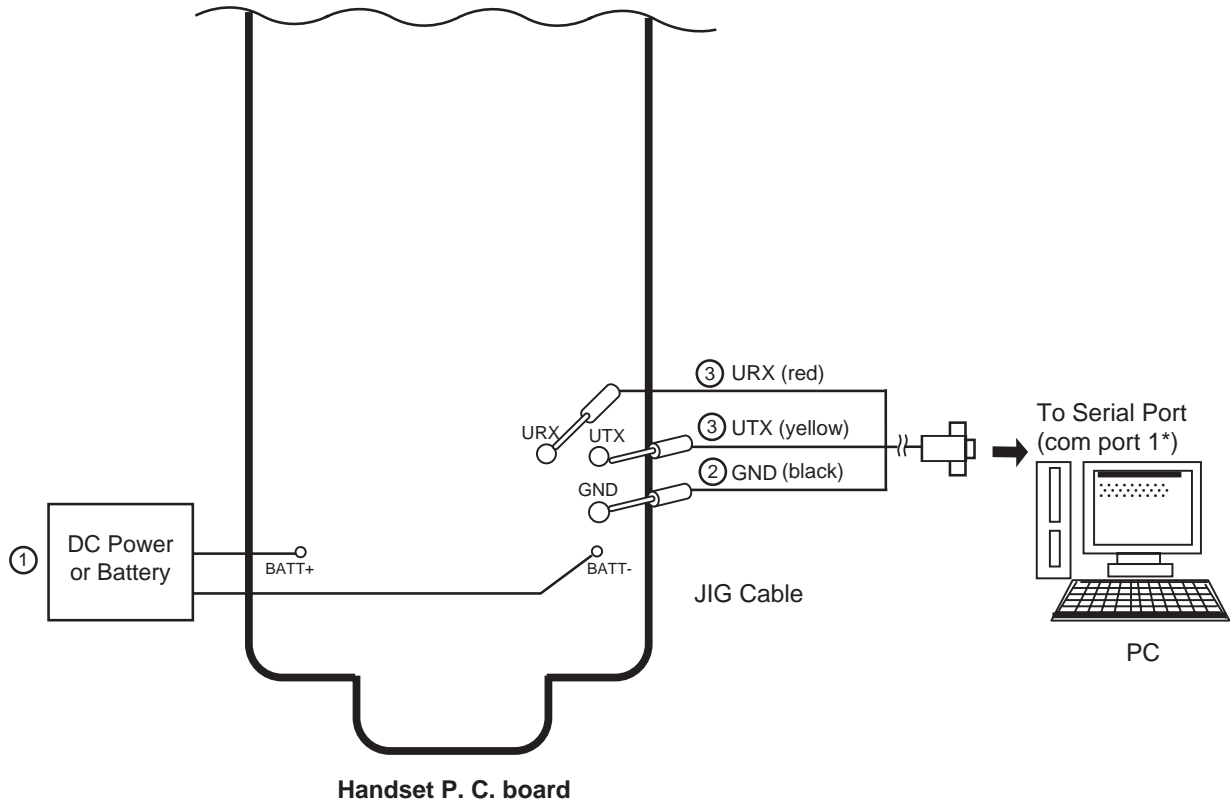

Note:

*: COM port names may vary depending on what your PC calls it.

12.2.3. Connections (Range Extender)

- ① Connect the AC adaptor.
- ② Connect the JIG Cable GND (black).
- ③ Connect the JIG Cable RX (red) and TX (yellow).

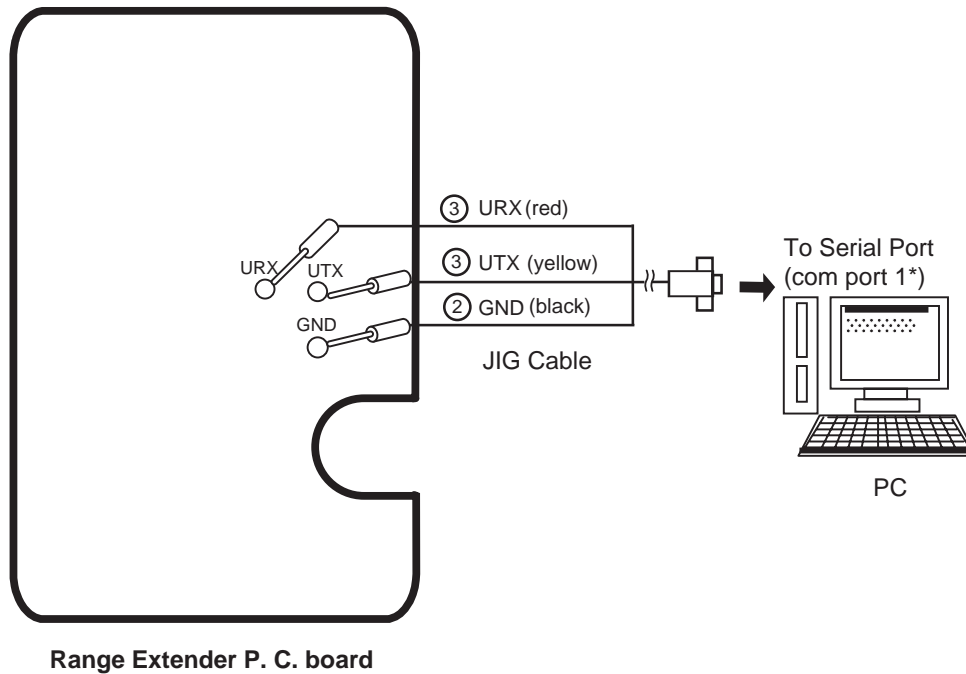

Note:

*: COM port names may vary depending on what your PC calls it.

12.2.4. How to install Batch file into P.C.

1. Insert the Batch file CD-ROM into CD-ROM drive and copy PNZZTG**** folder to your PC (example: D drive).

2. Open an MS-DOS mode window.

3. At the DOS prompt, type "D:" (for example) to select the drive, then press the **Enter** key.

4. Type "CD ¥PNZZTG****", then press the **Enter** key.

5. Type "SET_COM=X", then press the **Enter** key (X: COM port number used for the serial connection on your PC).

6. Type "READID", then press the **Enter** key.
 • If any error messages appear, change the port number or check the cable connection.
 • If any value appear, go to next step.

7. Type "DOSKEY", then press the **Enter** key.

<Example for Windows>

On your computer, click **[Start]**, select **Programs** (**All Programs** for Windows XP/Windows Server 2003), then click
MS-DOS Prompt. (for Windows 95/Windows 98)
 Or
Accessories-MS-DOS Prompt. (for Windows Me)
 Or
Command Prompt. (for Windows NT 4.0)
 Or
Accessories-Command Prompt. (for Windows 2000/Windows XP/Windows Server 2003)

<Example>

```
C: ¥Documents and Settings>D:
D: ¥>CD ¥PNZZTG****
D: ¥PNZZTG**** >SET_COM=X
D: ¥PNZZTG****>READID
00 52 4F A8 A8
D: ¥PNZZTG****>DOSKEY
D: ¥PNZZTG****>_
```

<Example: error happens>

```
C: ¥Documents and Settings>D:
D: ¥>CD ¥PNZZTG****
D: ¥PNZZTG**** >SET_COM=X
D: ¥PNZZTG****>READID
CreateFile error
ERROR 10: Can't open serial port
D: ¥PNZZTG ****>_
```

Note:

- "****" varies depending on the country or models.

12.2.5. Commands (Base Unit)

See the table below for frequently used commands.

Command name		Function	Example
rdeeprom		Read the data of EEPROM	Type "rdeeprom 00 00 FF", and the data from address "00 00" to "FF" is read out.
readid		Read ID (RFPI)	Type "readid", and the registered ID is read out.
writeid		Write ID (RFPI)	Type "writeid 00 18 E0 0E 98", and the ID "0018 E0 0E 98" is written.
hookoff		Off-hook mode on Base	Type "hookoff".
hookon		On-hook mode on Base	Type "hookon".
getchk		Read checksum	Type "getchk".
How to use of "getchk"	1.rdeeprom	Read EEPROM	Type "RdEeprom 03 F2 04", and the data from address "03 F2" to "03 F5" is read out *This command gets 4 byte "WW", "XX", "YY", "ZZ". *Please NEVER forget these 4 byte data!
	2.sendchar epw	Write EEPROM	Type "sendchar epw 03 F2 04 FF FF FF FF"
	3.sendchar RST	Reset baseset	Type "sendchar RST"
	4.getchk	Read checksum	Type "getchk".
	5.sendchar epw	Write EEPROM	Type "sendchar epw 03 F2 04 WW XX YY ZZ" *"WW", "XX", "YY", "ZZ" is 4 byte data that already read from same address.
wreeprom		Write the data of EEPROM	Type "wreeprom 01 23 45". "01 23" is address and "45" is data to be written.
bs_burst		Base unit outputs RF power in burst test mode on antenna 2	Type "bs_burst"
tx_high		Keep TX power high	Type "tx_high"
tx_low		Keep TX power low	Type "tx_low"

12.2.6. Commands (Handset)

See the table below for frequently used commands.

Command name		Function	Example
rdeeprom		Read the data of EEPROM	Type "rdeeprom 00 00 FF", and the data from address "00 00" to "FF" is read out.
readid		Read ID (RFPI)	Type "readid", and the registered ID is read out.
writeid		Write ID (RFPI)	Type "writeid 00 18 E0 0E 98", and the ID "0018 E0 0E 98" is written.
getchk		Read checksum	Type "getchk"
How to use of "getchk"	1.rdeeprom	Read EEPROM	Type "RdEeprom 03 7D 04", and the data from address "03 7D" to "03 80" is read out *NEVER forget the read 4 byte data!
	2.sendchar epw	Write EEPROM	Type "sendchar epw 03 7D 04 FF FF FF FF"
	3.sendchar RST	Reset baseset	Type "sendchar RST"
	4.getchk	Read checksum	Type "getchk".
	5.sendchar epw	Write EEPROM	Type "sendchar epw 03 7D 04 WW XX YY ZZ" *"WW", "XX", "YY", "ZZ" is 4 byte data that already read from same address.
weeprom		Write the data of EEPROM	Type "wreeprom 01 23 45". "01 23" is address and "45" is data to be written.
hs_burst		Handset outputs RF power in burst test mode	Type "hs_burst"
tx_high		Keep TX power high	Type "tx_high"
tx_low		Keep TX power low	Type "tx_low"

12.4. Adjustment Standard (Charger Unit)

When connecting the simulator equipment for checking, please refer to below.

12.4.1. Bottom View

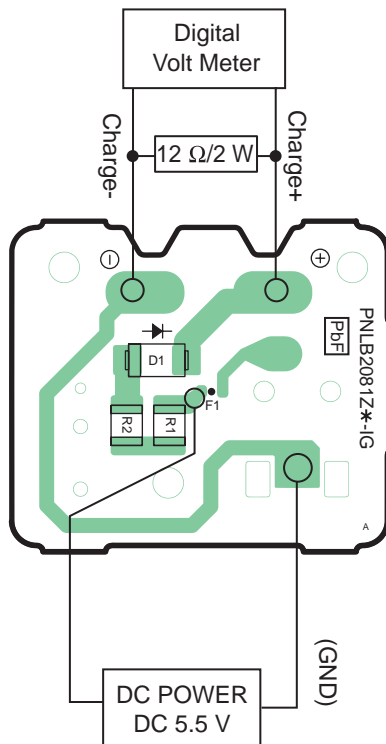

12.5. Adjustment Standard (Range Extender)

When connecting the simulator equipment for checking, please refer to below.

12.5.1. Bottom View

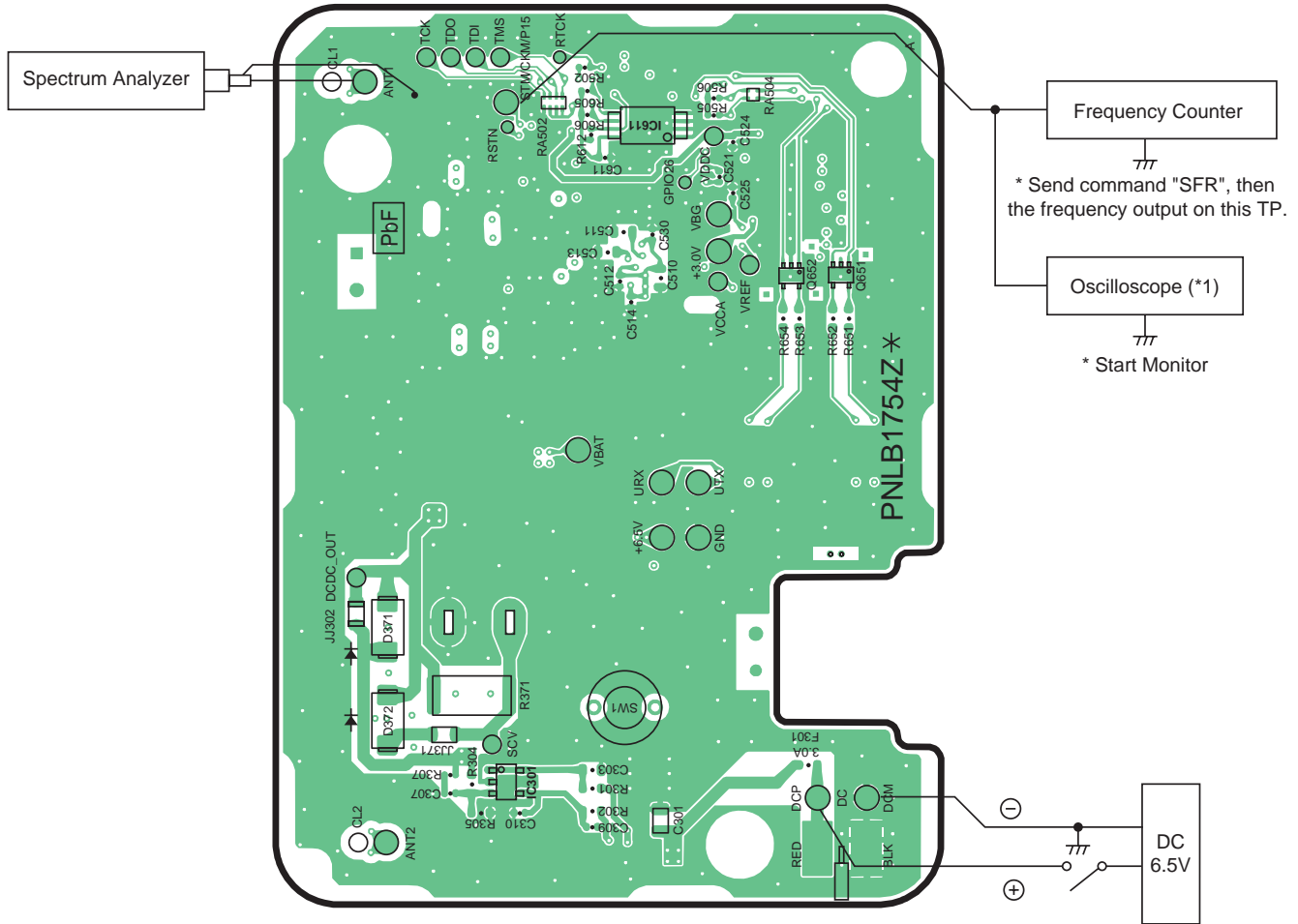

Note:

(*1) is referred to **Power Supply Circuit (P.24)**

12.7. Things to Do after Replacing IC or X'tal

If repairing or replacing EEPROM and X'tal, it is necessary to download the required data such as Programming data or adjustment data, etc in memory.

The set doesn't operate if it is not executed.

12.7.1. How to download the data

12.7.1.1. Base Unit

First, operate the PC setting according to **The Setting Method of JIG** (P.56).

Then download the appropriate data according to the following procedures.

Items		How to download/Required adjustment
EEPROM (IC611)	Adjusted parameter data is stored in memory. (country version batch file, default batch file, etc.)	<ol style="list-style-type: none"> 1) Change the address "0001" of EEPROM to "55" to download the data. 2) Default batch file: Execute the command "default.bat". 3) Country version batch file: Execute the command "TG4741US_US_RevXXX_YYY.bat". (*1) 4) Clock adjustment
X'tal (X1)	System clock	<p>Clock adjustment data is in EEPROM, adjust the data again after replacing it.</p> <ol style="list-style-type: none"> 1) Apply 5.5V between DCP and DCM with DC power. 2) Input Command "sendchar sfr", then you can confirm the current value. 3) Check X'tal Frequency.(13.824 MHz \pm 100 Hz). 4) If the frequency is not 13.824 MHz \pm 100 Hz, adjust the frequency of CLK executing the command "sendchar sfr xx xx (where xx is the value)" so that the reading of the frequency counter is 13.824000 MHz \pm 15 Hz.

Note:

(*1) XXX_YYY: revision number

"XXX", "YYY" vary depending on the country version. You can find them in the batch file, PNZZ- mentioned in **The Setting Method of JIG** (P.56).

12.7.1.2. Handset

First, operate the PC setting according to **The Setting Method of JIG** (P.56).
Then download the appropriate data according to the following procedures.

Items		How to download/Required adjustment
EEPROM (IC3)	Adjusted parameter data is stored in memory. (country version batch file, default batch file, etc.)	<ol style="list-style-type: none"> 1) Default batch file: Execute the command "default.bat". 2) Default batch file (remaining): Execute the command "TGA470US_DEF_RevXXX_YYY.bat". (*2) 3) Country version batch file: Execute the command "TGA470US_US_RevXXX_YYY.bat". (*2) 4) Clock adjustment 5) 2.35 V setting and battery low detection
X'tal (X1)	System clock	<ol style="list-style-type: none"> 1) Apply 2.6V between BATT+ and BATT- with DC power. 2) Input Command "sendchar sfr", then you can confirm the current value. 3) Check X'tal Frequency.(13.824 MHz \pm 100 Hz). 4) If the frequency is not 13.824 MHz \pm 100 Hz, adjust the frequency of CLK executing the command "sendchar sfr xx xx (where xx is the value)" so that the reading of the frequency counter is 13.824000 MHz \pm 5 Hz.

Note:

(*2) XXX_YYY: revision number

"XXX" and "YYY" vary depending on the country version. You can find them in the batch file, PNZZ- mentioned in **The Setting Method of JIG** (P.56).

12.7.1.3. Range Extender

First, operate the PC setting according to **The Setting Method of JIG** (P.56).
Then download the appropriate data according to the following procedures.

Items		How to download/Required adjustment
EEPROM (IC611)	Adjusted parameter data is stored in memory. (country version batch file, default batch file, etc.)	<ol style="list-style-type: none"> 1) Change the address "0000" of EEPROM to "22" to download the data. 2) Default batch file: Execute the command "TGA405USUSrevXXX_YYY.bat. (*3)". 3) Clock adjustment
X'tal (X501)	System clock	<p>Clock adjustment data is in EEPROM, adjust the data again after replacing it.</p> <ol style="list-style-type: none"> 1) Apply 6.5V between DCP and DCM with DC power. 2) Input Command "sendchar sfr", then you can confirm the current value. 3) Check X'tal Frequency.(13.824 MHz \pm 100 Hz). 4) If the frequency is not 13.824 MHz \pm 100 Hz, adjust the frequency of CLK executing the command "sendchar sfr xx xx (where xx is the value)" so that the reading of the frequency counter is 13.824000 MHz \pm 15 Hz.

Note:

(*3) XXX: country code, YYY: revision number.

"XXX" and "YYY" vary depending on the country version. You can find them in the batch file, PNZZ- mentioned in **The Setting Method of JIG** (P.56).

12.8. Frequency Table

	Ch. (hex)	TX/RX Frequency (MHz)
Channel 0	00	1928.448
Channel 1	01	1926.720
Channel 2	02	1924.992
Channel 3	03	1923.264
Channel 4	04	1921.536

13 Miscellaneous

13.1. How to Replace the LLP (Leadless Leadframe Package) IC

Note:

This description is only applied on the model with Shield case.

13.1.1. Preparation

- PbF (: Pb free) Solder
- Soldering Iron
Tip Temperature of 700 °F ± 20 °F (370 °C ± 10 °C)

Note:

We recommend a 30 to 40 Watt soldering iron. An expert may be able to use a 60 to 80 Watt iron where someone with less experience could overheat and damage the PCB foil.

- Hot Air Desoldering Tool
Temperature: 608 °F ± 68 °F (320 °C ± 20 °C)

13.1.2. Caution

- To replace the IC efficiently, choose the right sized nozzle of the hot air desoldering tool that matches the IC package.
- Be careful about the temperature of the hot air desoldering tool not to damage the PCB and/or IC.

13.1.3. How to Remove the IC

1. Heat the IC with a hot air desoldering tool through the P.C.Board.

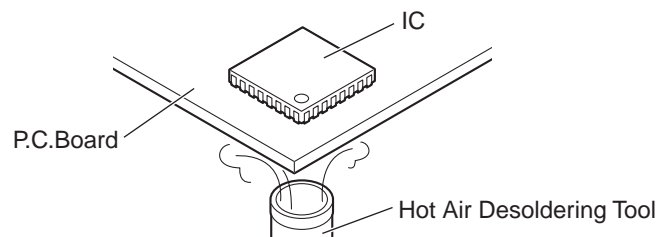

2. Pick up the IC with tweezers, etc. when the solder is melted completely.

Note:

- Be careful not to touch the peripheral parts with tweezers, etc. They are unstable.

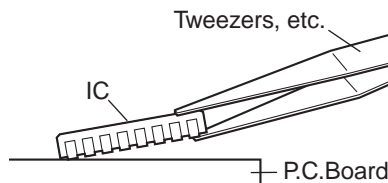

When it is hard to melt the solder completely, heat it with a hot air desoldering tool through the IC besides through the P.C.Board.

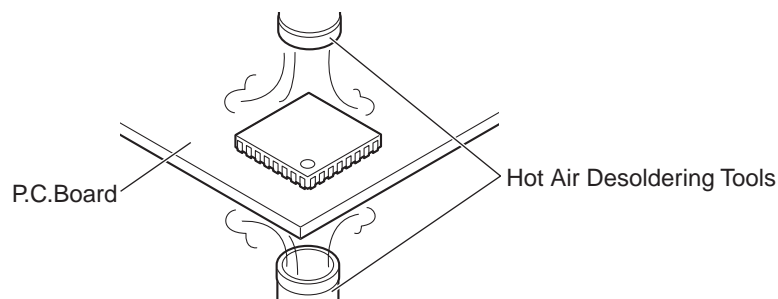

3. After removing the IC, clean the P.C.Board of residual solder.

13.1.4. How to Install the IC

1. Place the solder a little on the land where the radiation GND pad on IC bottom is to be attached.

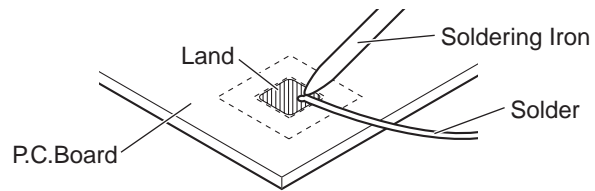

2. Place the solder a little on the land where IC pins are to be attached, then place the IC.

Note:

- When placing the IC, the positioning should be done very carefully.

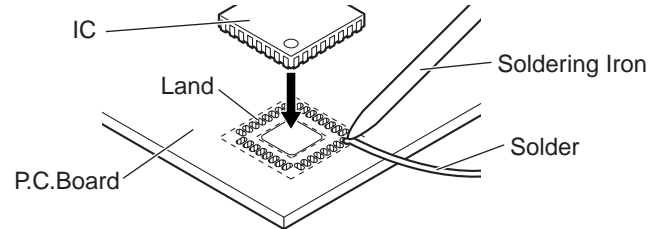

3. Heat the IC with a hot air desoldering tool through the P.C.Board until the solder on IC bottom is melted.

Note:

- Be sure to place it precisely, controlling the air volume of the hot air desoldering tool.

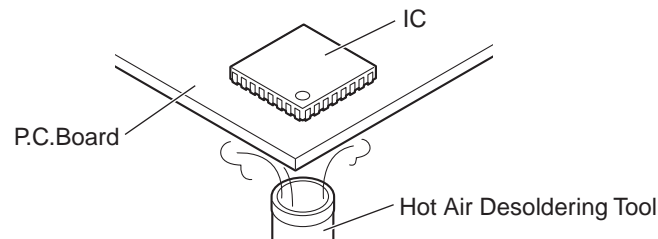

4. After soldering, confirm there are no short and open circuits with visual inspection.

13.2. How to Replace the Flat Package IC

Even if you do not have the special tools (for example, a spot heater) to remove the Flat IC, with some solder (large amount), a soldering iron and a cutter knife, you can easily remove the ICs that have more than 100 pins.

13.2.1. Preparation

- PbF (: Pb free) Solder

- Soldering Iron

Tip Temperature of 700 °F ± 20 °F (370 °C ± 10 °C)

Note: We recommend a 30 to 40 Watt soldering iron. An expert may be able to use a 60 to 80 Watt iron where someone with less experience could overheat and damage the PCB foil.

- Flux

Recommended Flux: Specific Gravity → 0.82.

Type → RMA (lower residue, non-cleaning type)

Note: See **About Lead Free Solder (PbF: Pb free)** (P.5)

13.2.2. How to Remove the IC

1. Put plenty of solder on the IC pins so that the pins can be completely covered.

Note:

If the IC pins are not soldered enough, you may give pressure to the P.C. board when cutting the pins with a cutter.

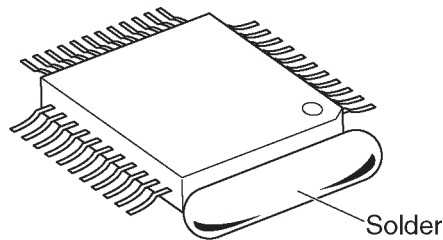

2. Make a few cuts into the joint (between the IC and its pins) first and then cut off the pins thoroughly.

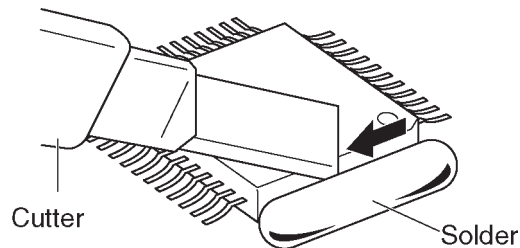

3. While the solder melts, remove it together with the IC pins.

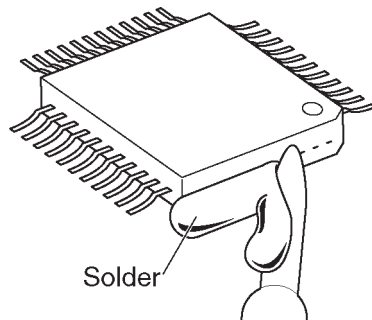

When you attach a new IC to the board, remove all solder left on the board with some tools like a soldering wire. If some solder is left at the joint on the board, the new IC will not be attached properly.

13.2.3. How to Install the IC

1. Temporarily fix the FLAT PACKAGE IC, soldering the two marked pins.

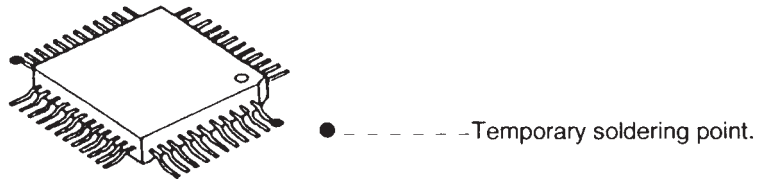

*Check the accuracy of the IC setting with the corresponding soldering foil.

2. Apply flux to all pins of the FLAT PACKAGE IC.

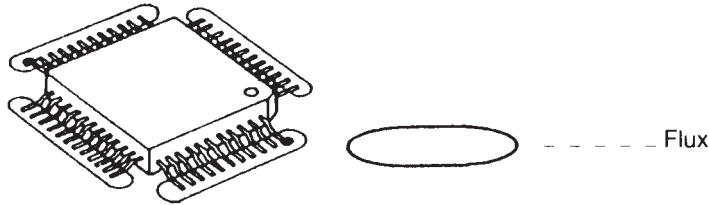

3. Solder the pins, sliding the soldering iron in the direction of the arrow.

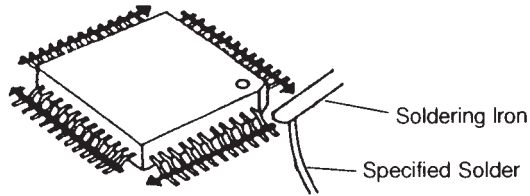





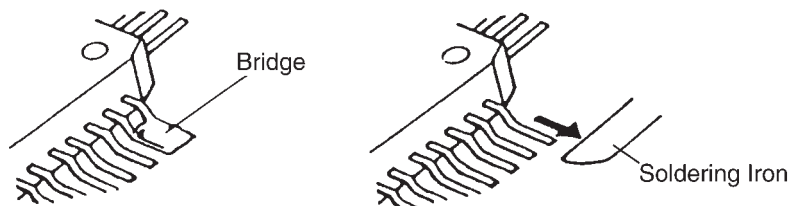

13.2.4. How to Remove a Solder Bridge

1. Lightly resolder the bridged portion.
2. Remove the remaining solder along the pins using a soldering iron as shown in the figure below.

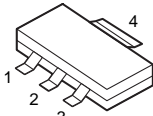
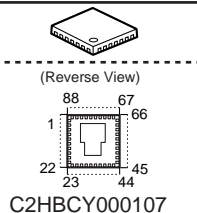
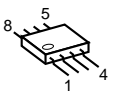
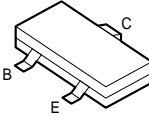

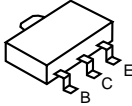
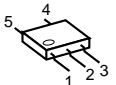

13.3. Terminal Guide of the ICs, Transistors and Diodes

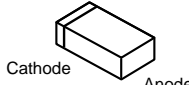
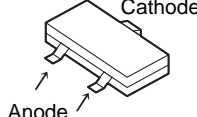
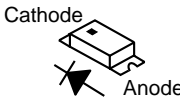
13.3.1. Base Unit

 <p>C0DBEYY00102</p>	 <p>(Reverse View) C2HBCY000107</p>	 <p>PNW11TG4741H PNW12TG4741H</p>	 <p>2SC6054JSL, B1ABDM000001 DRC9113Z0L, 2SA1576S B1GBCFYY0020</p>	
 <p>B1ACGP000008</p>	 <p>DSC7003S0L</p>	 <p>PSVTUMG11NTR</p>	 <p>PQVDMD5S</p>	 <p>DA2J10100L</p>
 <p>PQVDPTZT2530</p>	 <p>B0ECKM000008</p>	 <p>B0DDCD000001</p>	 <p>B3AAB0000347 LNJ237W82RA</p>	

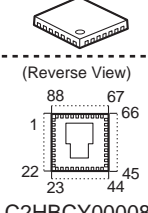
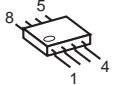
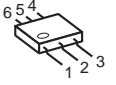
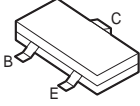
13.3.2. Handset

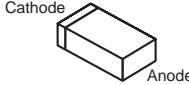
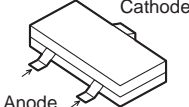
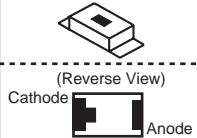
 <p>(Reverse View) C2HBCY000081</p>	 <p>PNWITGA470BR</p>	 <p>C0DBZYY00357</p>	 <p>B1ADCFO000040 DRC9113Z0L 2SC6054JSL</p>	 <p>B1ABGE000011</p>
 <p>B0BC4R3A0006</p>	 <p>B0DDCD000001</p>	 <p>(Reverse View) B3ACB0000190</p>		

13.3.3. Charger

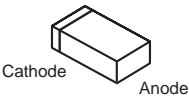
 <p>B0ECKM000008</p>

13.3.4. Range Extender

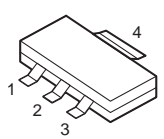
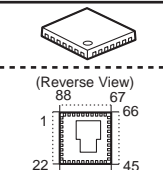
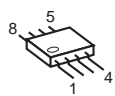
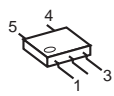
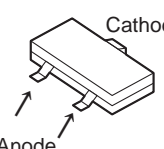
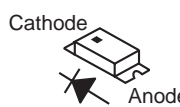
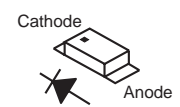
 <p>C0CBAYG00016</p>	 <p>(Reverse View)</p> <p>C2HBCY000046</p>	 <p>PNWITG405BR</p>	 <p>B1GFCFEN0011</p>	 <p>Cathode</p> <p>Anode</p> <p>B0DDCD000001</p>
 <p>Cathode</p> <p>Anode</p> <p>LNJ237W82RA</p>	 <p>Cathode</p> <p>Anode</p> <p>LNJ308G8JRA</p>			

14 Schematic Diagram

14.1. For Schematic Diagram

14.1.1. Base Unit (Schematic Diagram (Base Unit_Main))

Notes:

1. DC voltage measurements are taken with voltmeter from the negative voltage line.

Important Safety Notice:

Components identified by \triangle mark have special characteristics important for safety. When replacing any of these components, use only the manufacture's specified parts.

2. The schematic diagrams may be modified at any time with the development of new technology.

14.1.2. Handset (Schematic Diagram (Handset_Main))

Notes:

1. DC voltage measurements are taken with an oscilloscope or a tester with a ground.
2. The schematic diagrams may be modified at any time with the development of new technology.

14.1.3. Charger Unit (Schematic Diagram (Charger Unit))

Notes:

1. DC voltage measurements are taken with voltmeter from the negative voltage line.

Important Safety Notice:

Components identified by \triangle mark have special characteristics important for safety. When replacing any of these components, use only the manufacture's specified parts.

2. The schematic diagrams may be modified at any time with the development of new technology.

14.2. Schematic Diagram (Base Unit_Main)

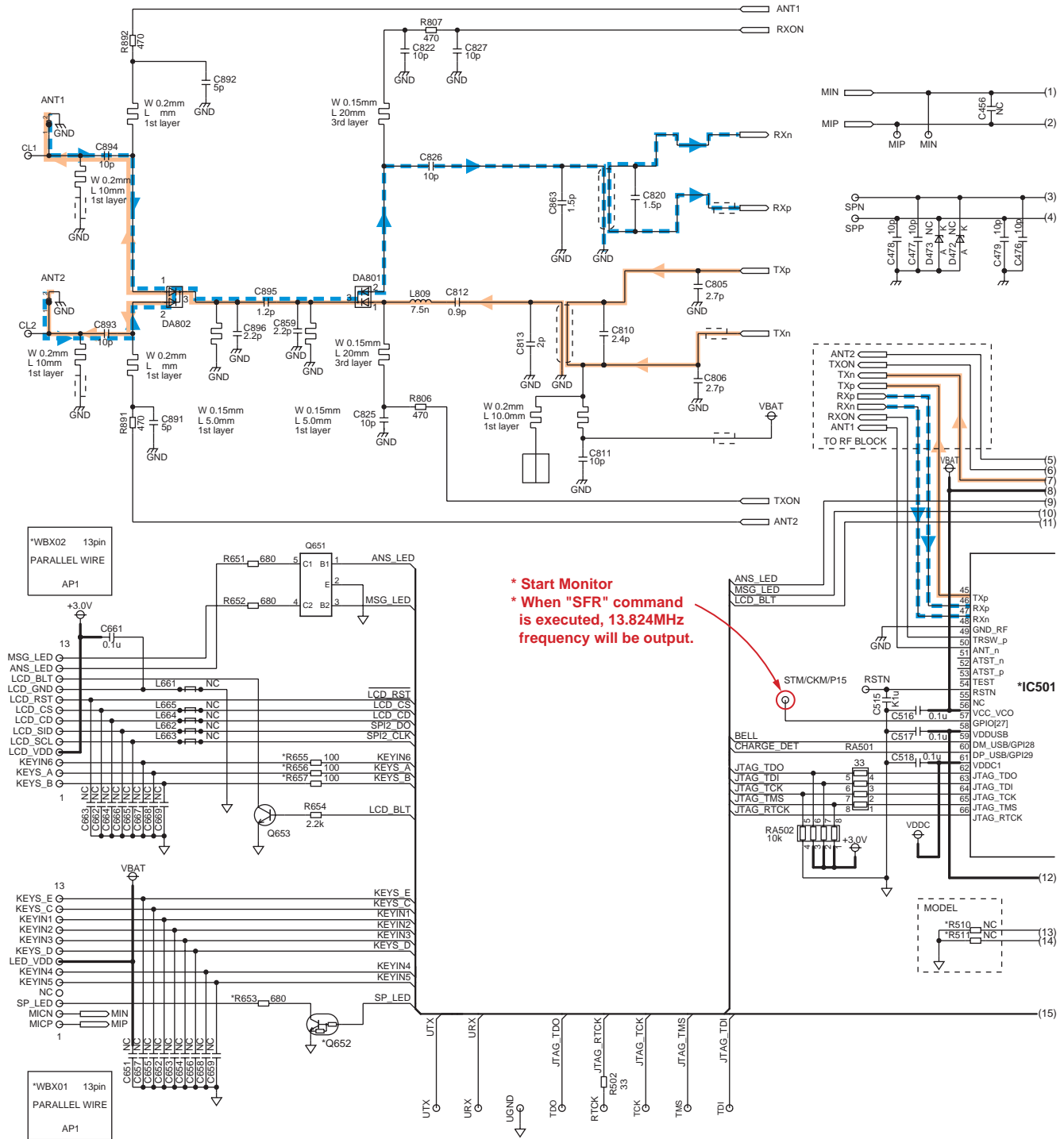

NC: No Components

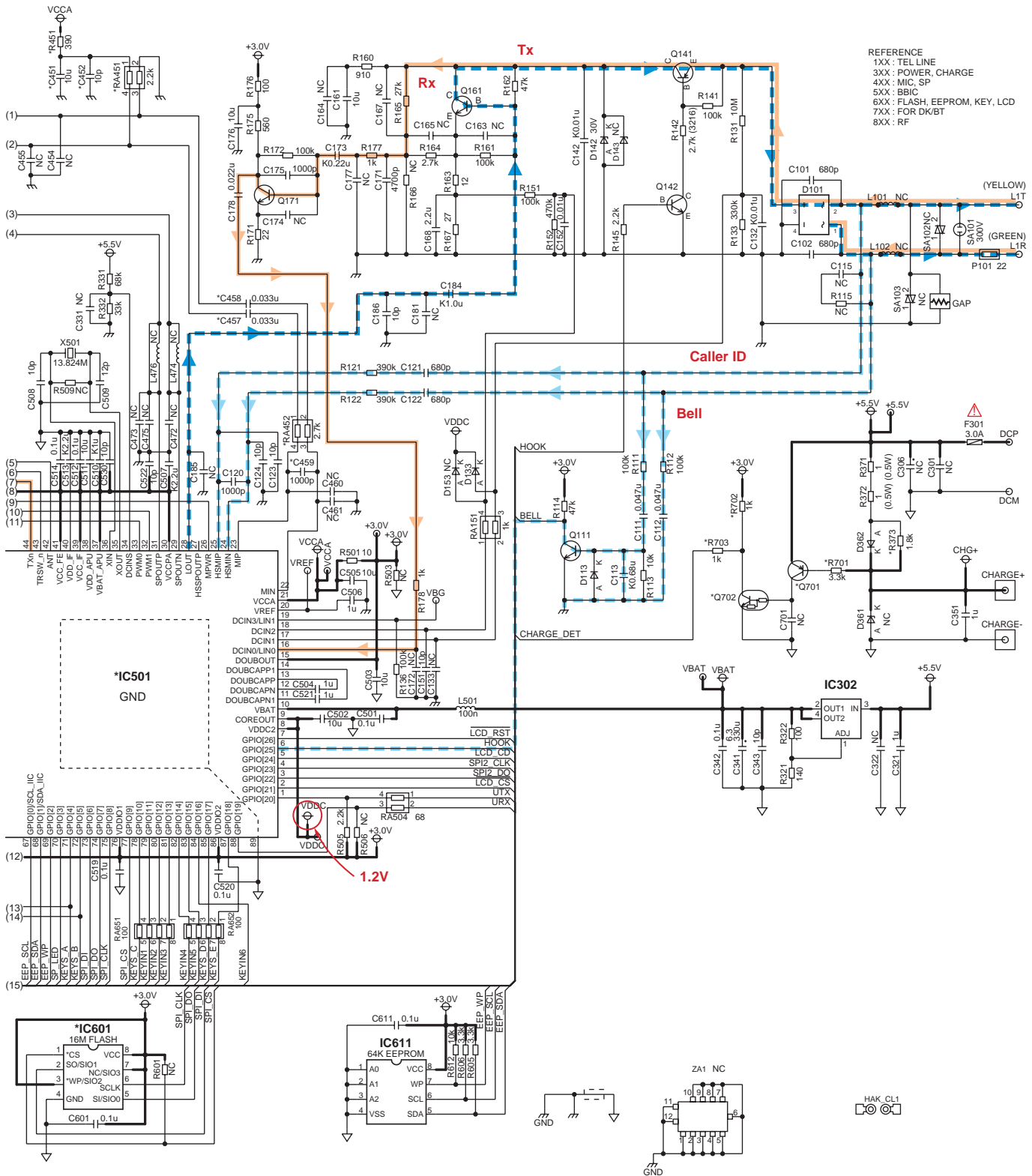

NC: No Components
 KX-TG4763 SCHEMATIC DIAGRAM (Base Unit_Main)

14.3. Schematic Diagram (Base Unit_Operation)

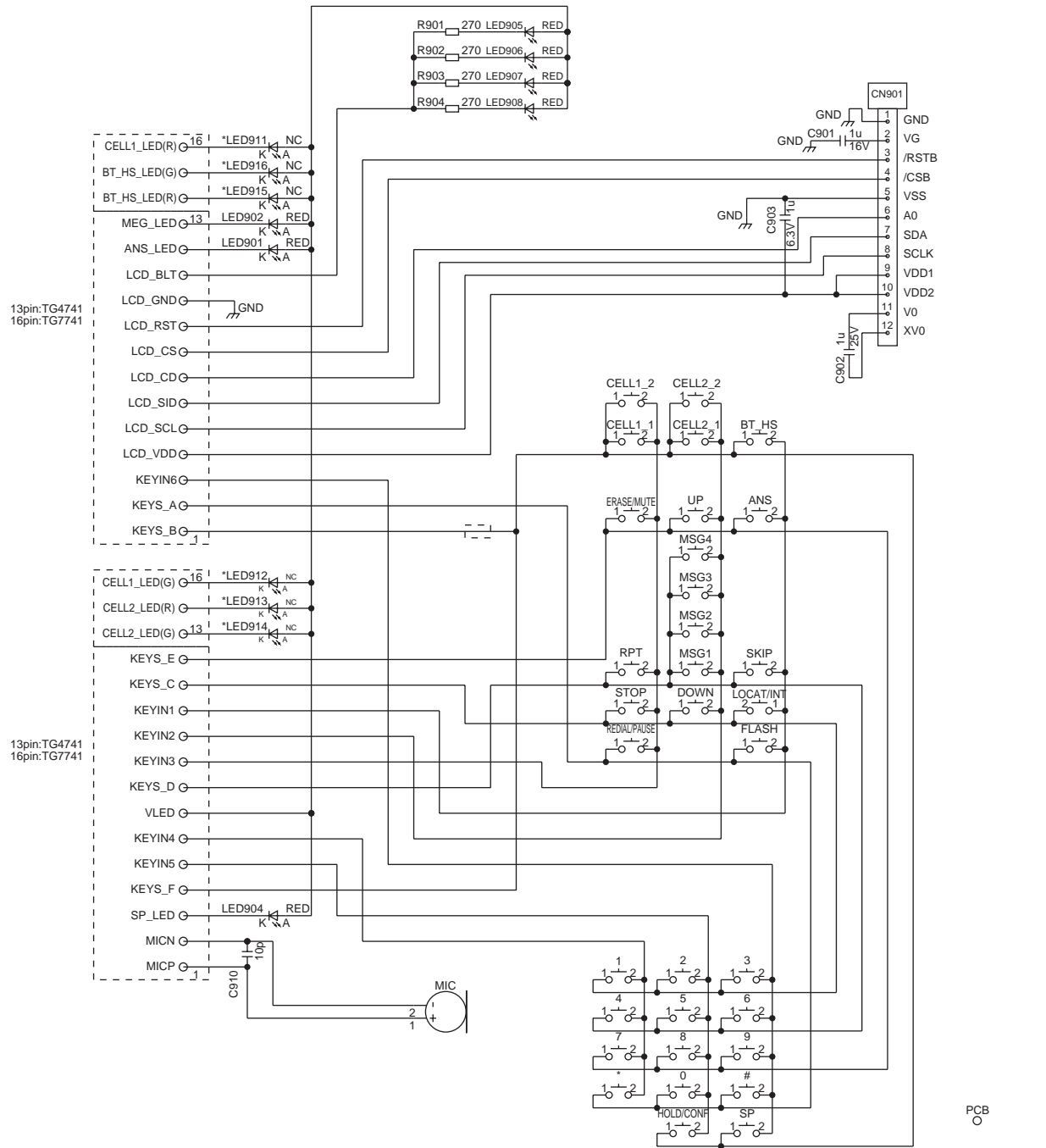

FOR TG7741, TG4741

CT2 CT1 CARBON_TEST

NC: No Components

KX-TG4763 SCHEMATIC DIAGRAM (Base Unit_Operation)

Memo

14.5. Schematic Diagram (Handset_LED)

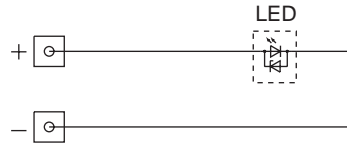

KX-TGA470 SCHEMATIC DIAGRAM (Handset_LED)

14.6. Schematic Diagram (Charger Unit)

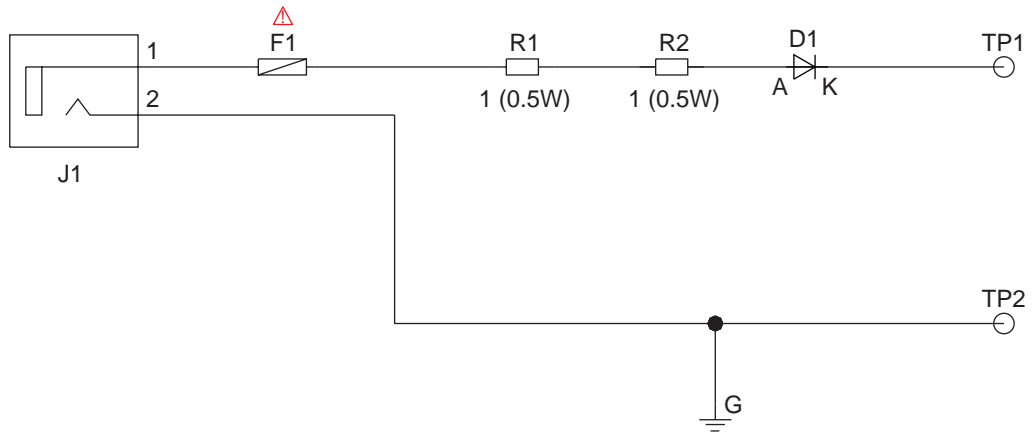

SCHEMATIC DIAGRAM (Charger Unit)

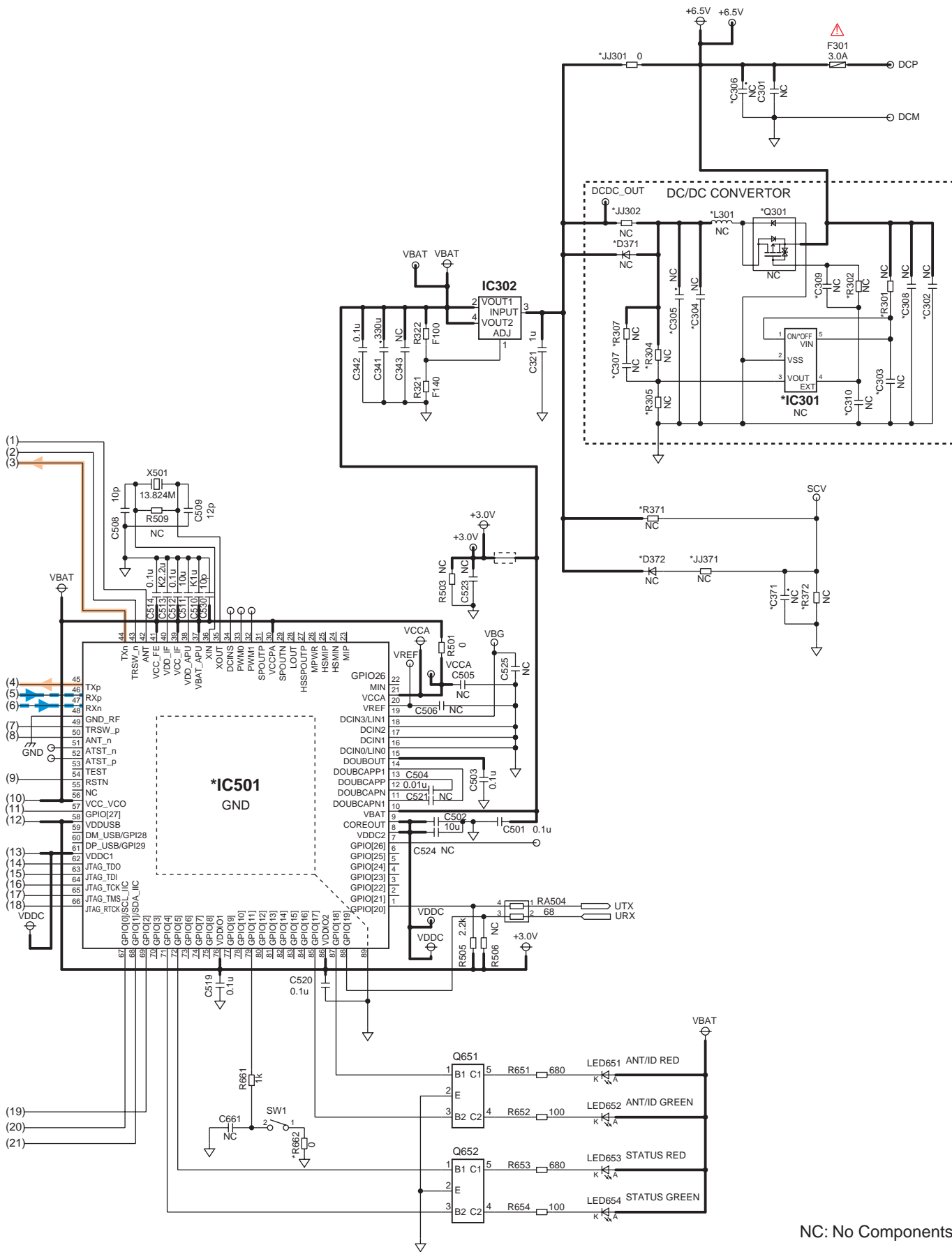

NC: No Components

KX-TGA405 SCHEMATIC DIAGRAM (Range Extender)

Memo

15.1.2. Bottom View

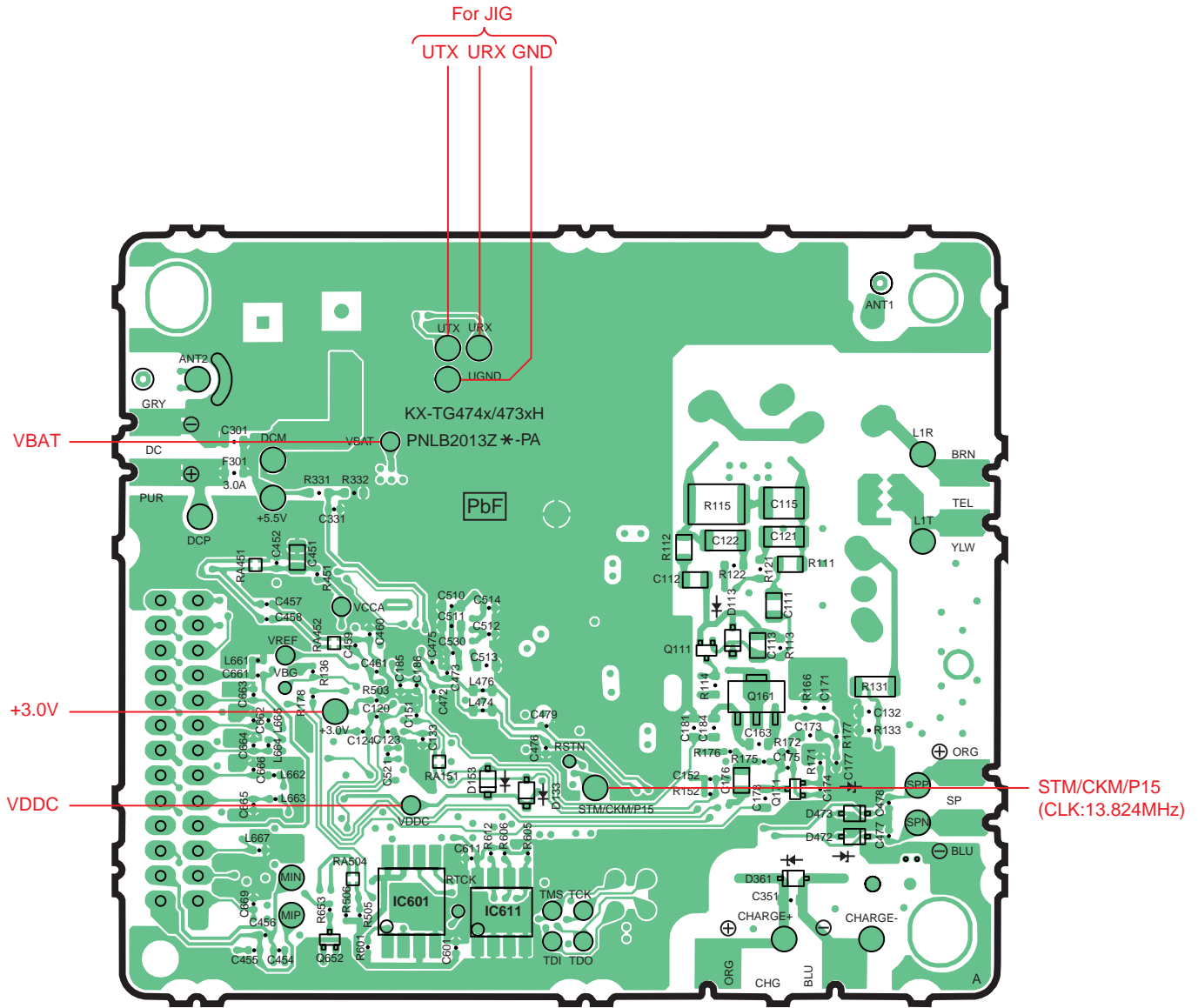

KX-TG4763 CIRCUIT BOARD (Base Unit_Main (Bottom View))

15.2. Circuit Board (Base Unit_Operation)

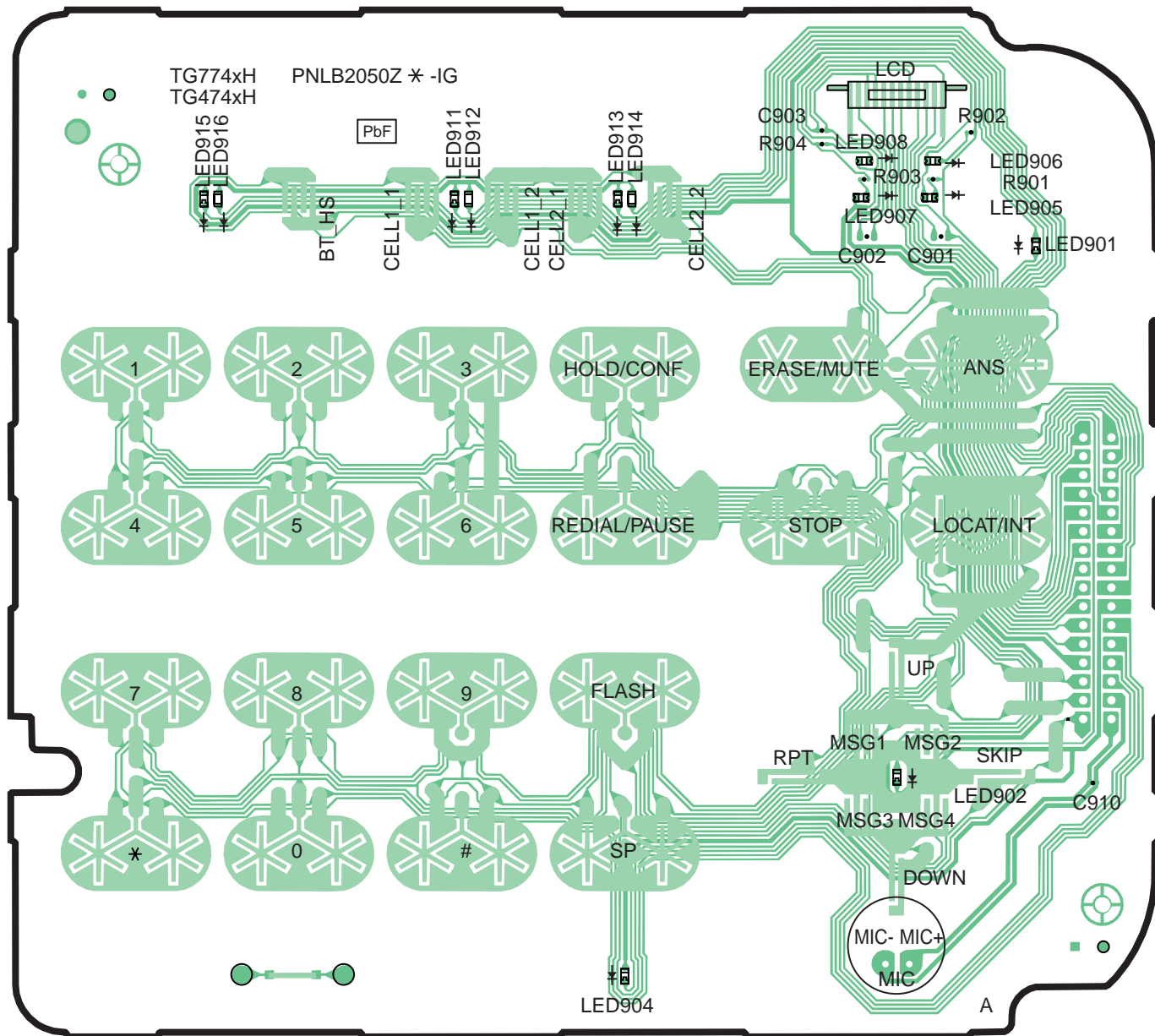

KX-TG4763 CIRCUIT BOARD (Base Unit_Operation (Component View))

Memo

15.3. Circuit Board (Handset_Main)

15.3.1. Component View

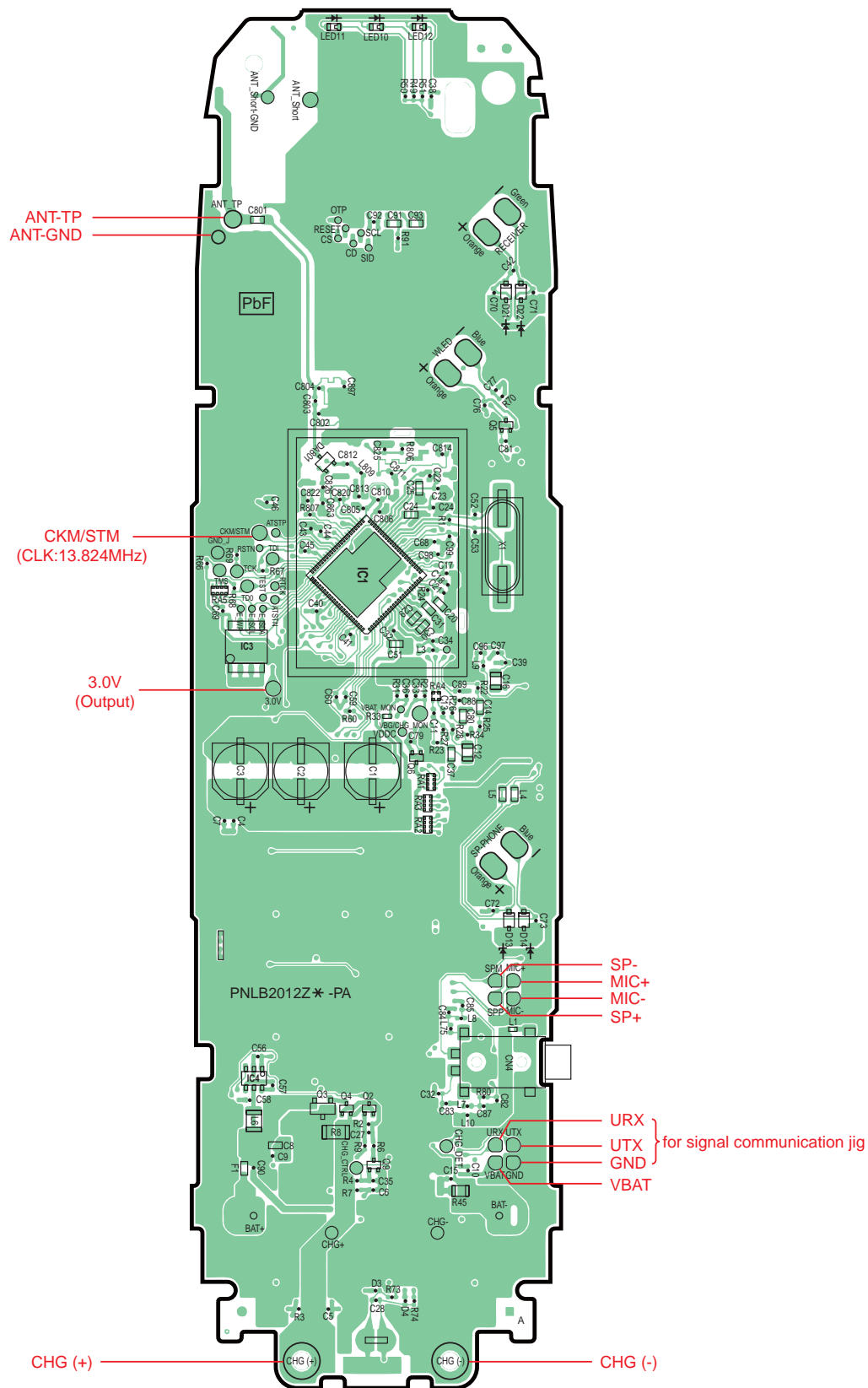

KX-TGA470 CIRCUIT BOARD (Handset_Main (Component View))

15.3.2. Bottom View

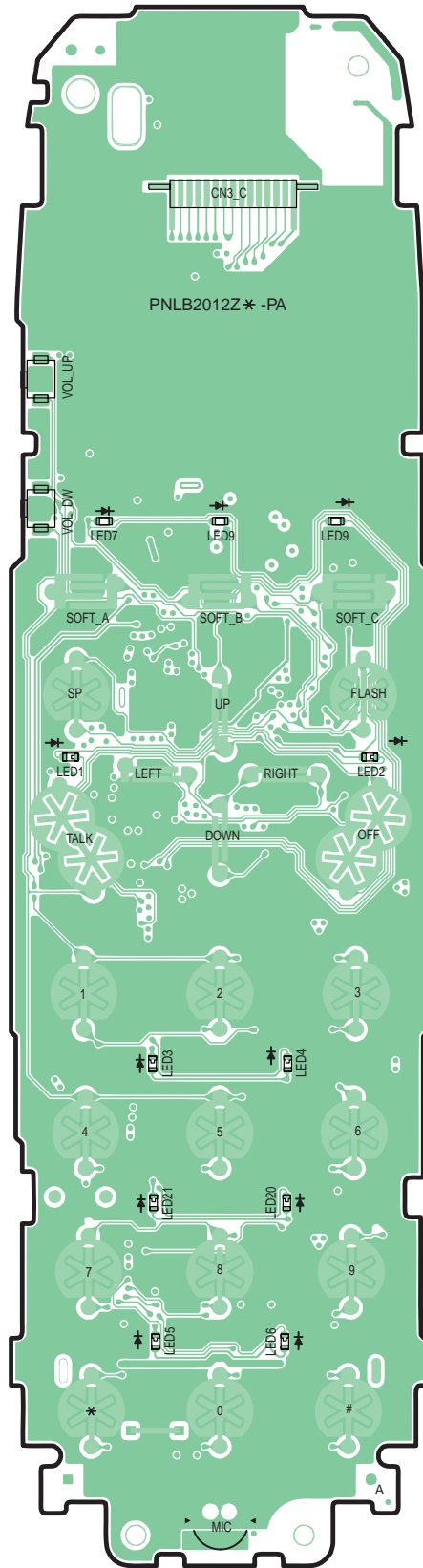

KX-TGA470 CIRCUIT BOARD (Handset_Main (Bottom View))

15.4. Circuit Board (Handset_LED)



KX-TGA470 CIRCUIT BOARD (Handset_LED (Component View))

15.5. Circuit Board (Charger Unit)

15.5.1. Component View

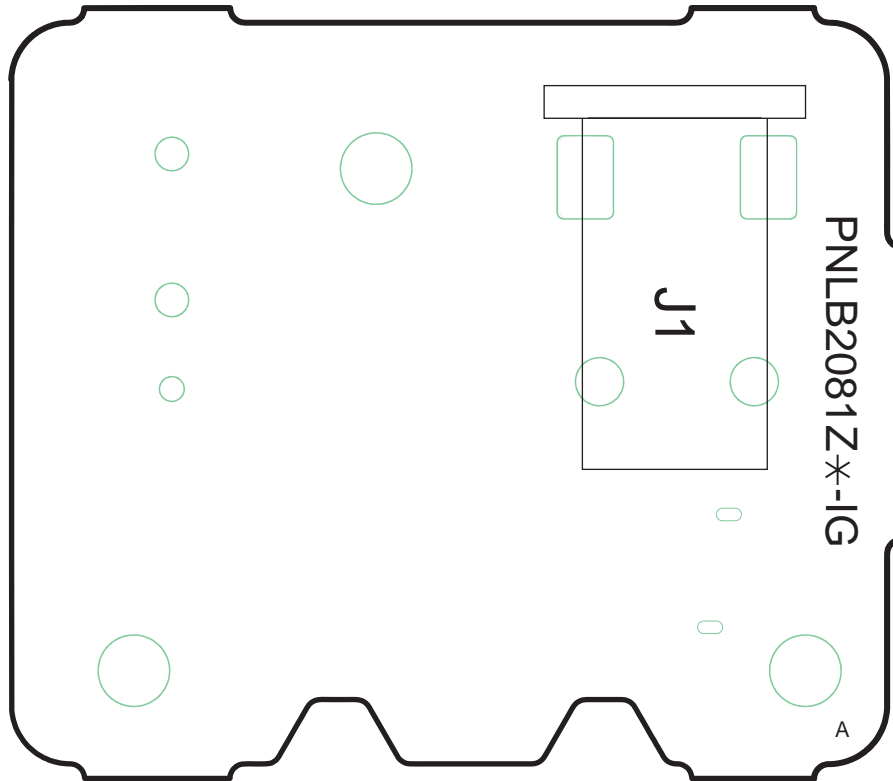

CIRCUIT BOARD (Charger Unit (Component View))

15.5.2. Bottom View

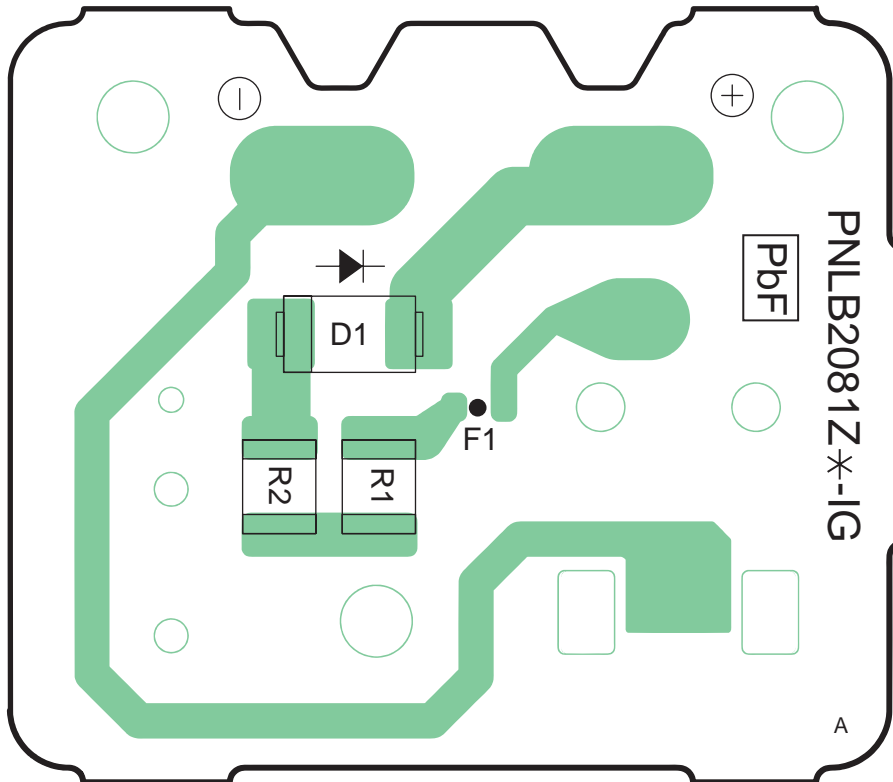

CIRCUIT BOARD (Charger Unit (Bottom View))

15.6.2. Bottom View

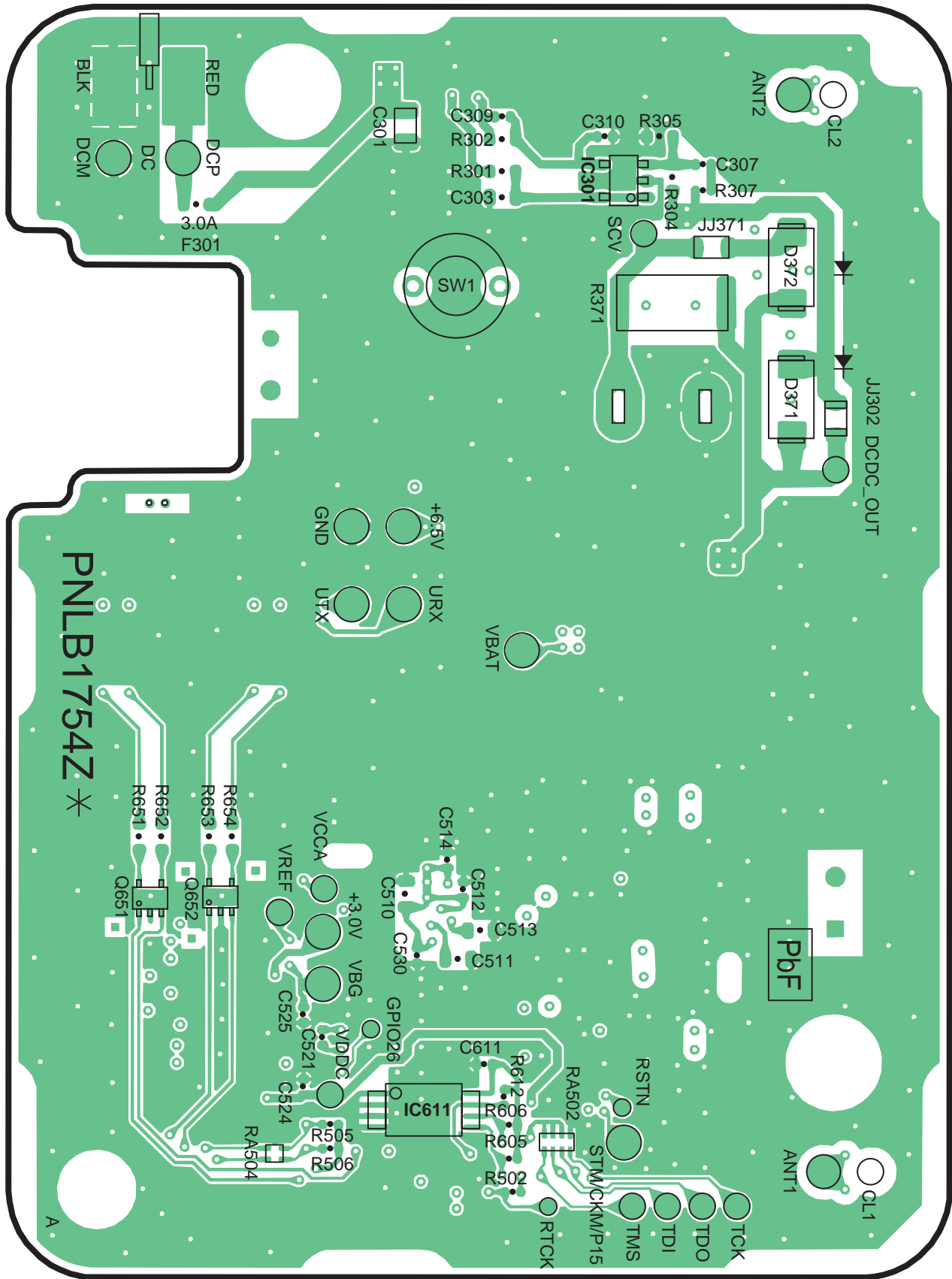

KX-TGA405 CIRCUIT BOARD (Range Extender (Bottom View))

16 Exploded View and Replacement Parts List

16.1. Cabinet and Electrical Parts (Base Unit)

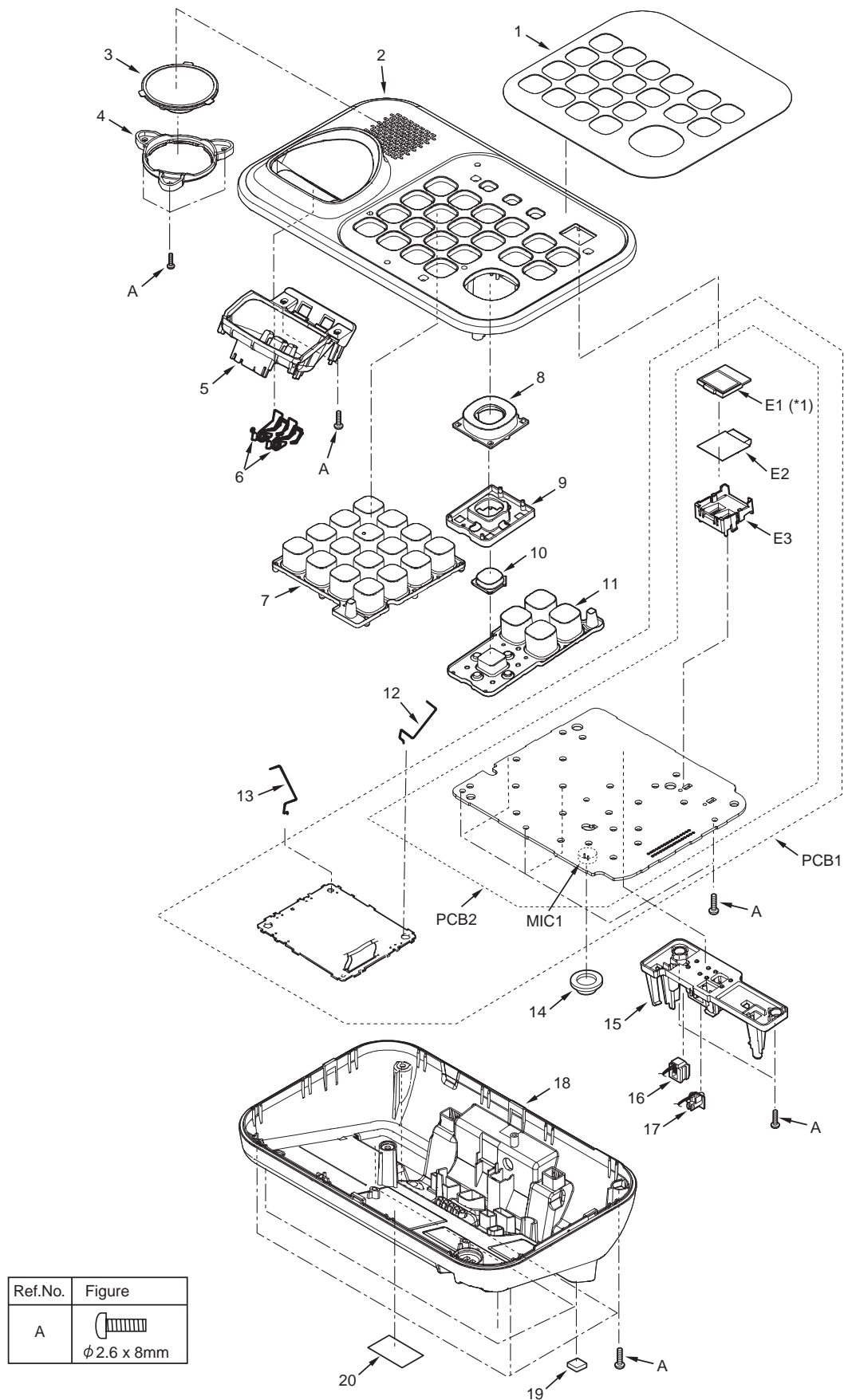

Ref.No.	Figure
A	 φ 2.6 x 8mm

Note:

(*1) This cable is fixed by welding. Refer to **How to Replace the Base Unit LCD (P.53)**.

16.2. Cabinet and Electrical Parts (Handset)

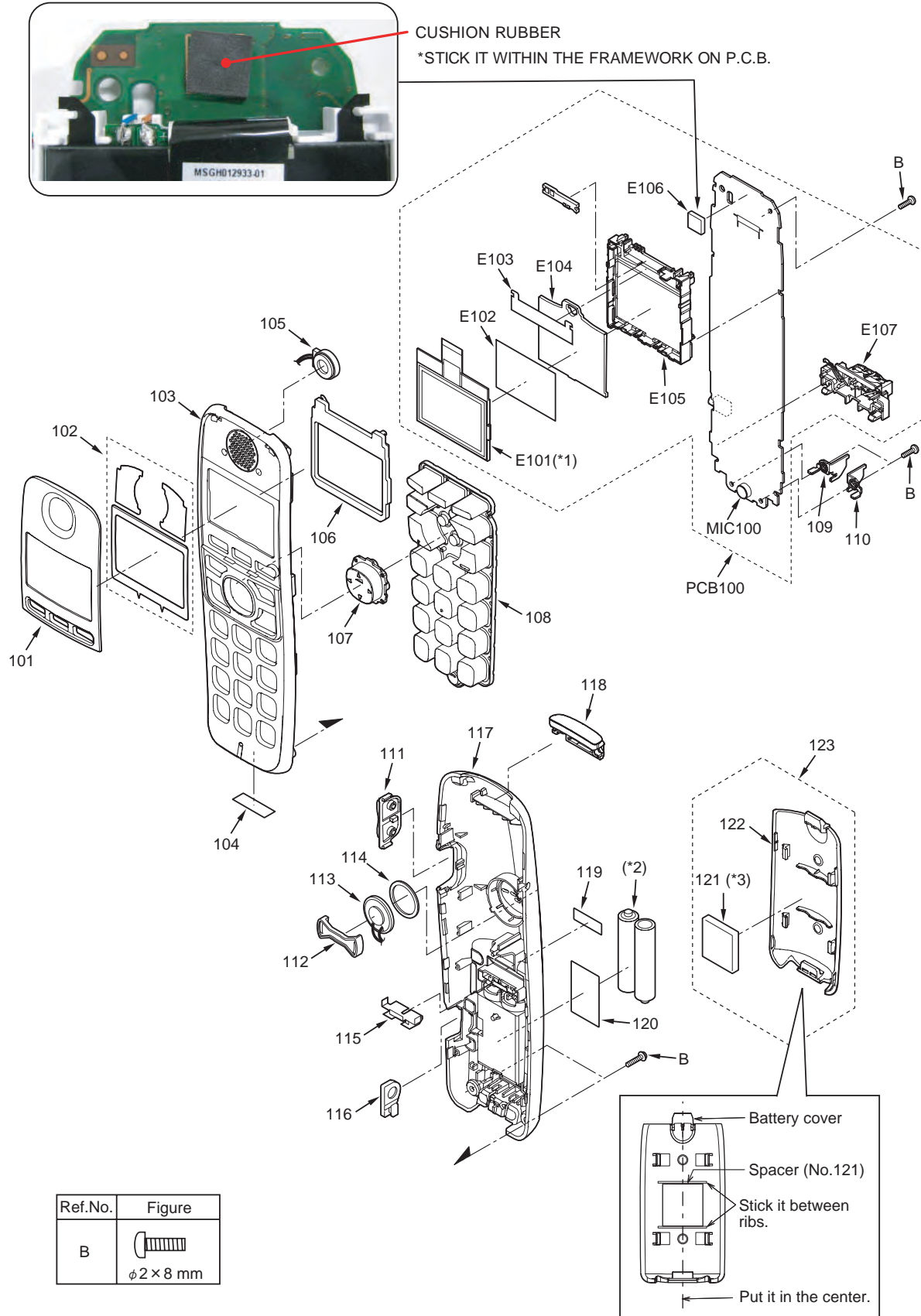

Note:

(*1) This cable is fixed by welding. Refer to **How to Replace the Handset LCD** (P.55).

(*2) The rechargeable Ni-MH battery HHR-4DPA is available through sales route of Panasonic.

(*3) Attach the SPACER (No. 121) to the exact location described above.

16.3. Cabinet and Electrical Parts (Charger Unit)

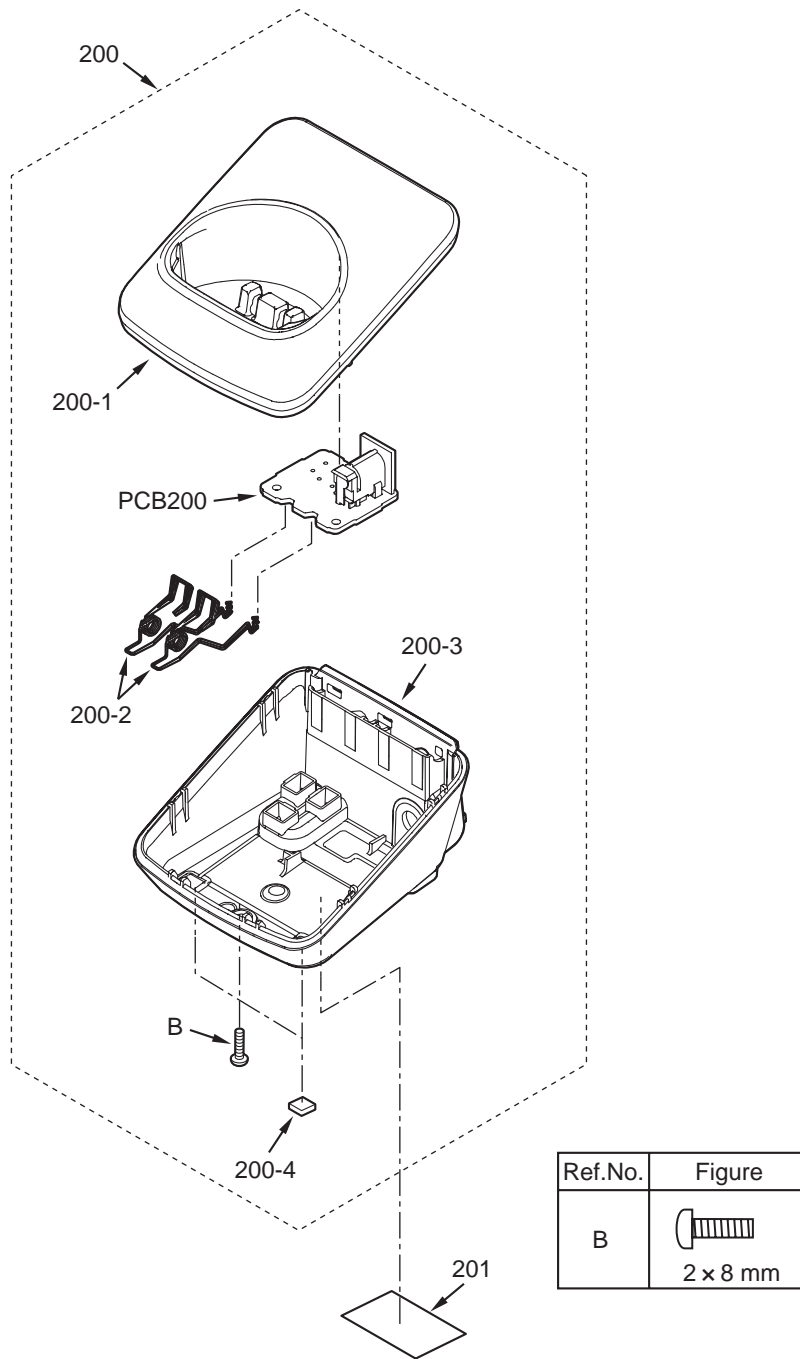

Ref.No.	Figure
B	 2 x 8 mm

16.4. Cabinet and Electrical Parts (Range Extender)

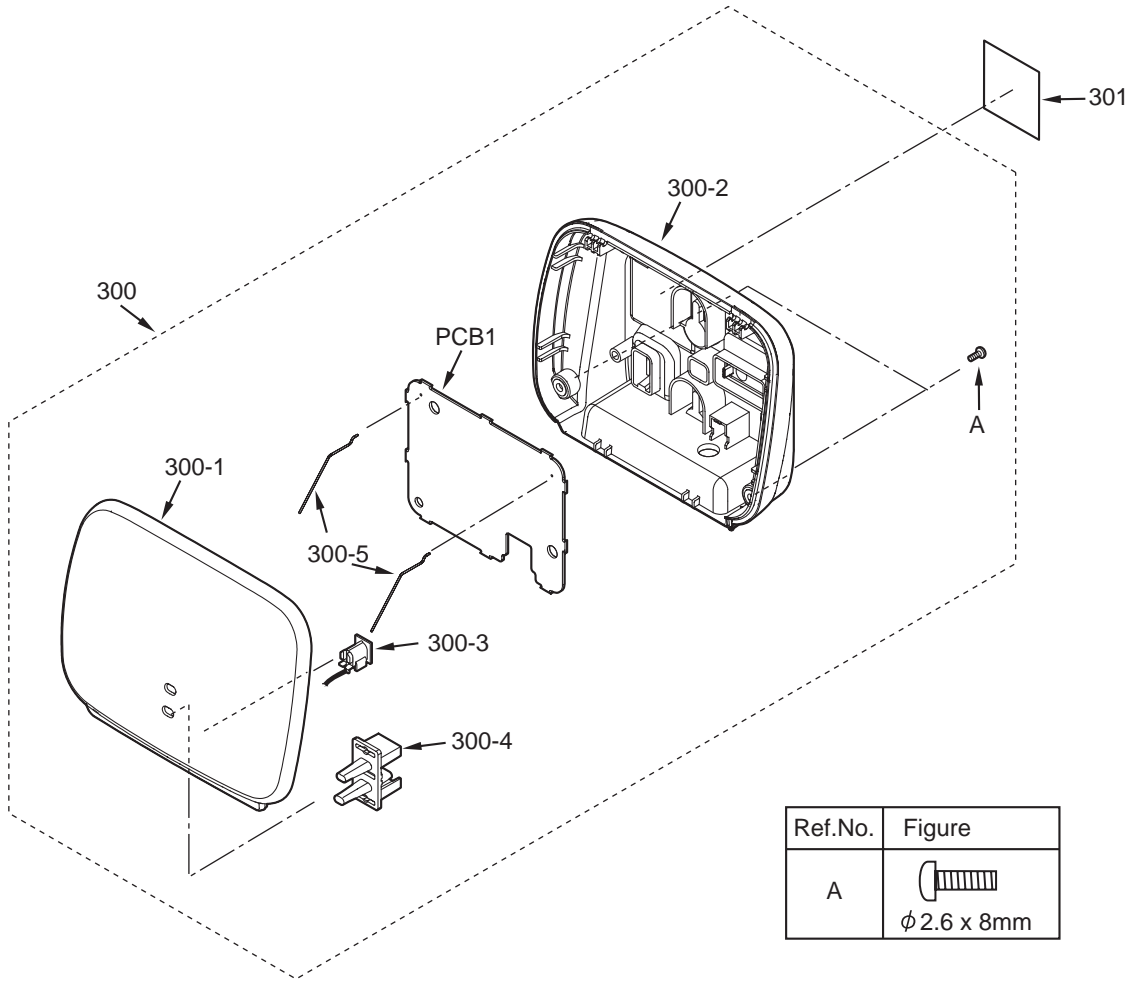

16.5. Accessories and Packing Materials

16.5.1. KX-TG4763B

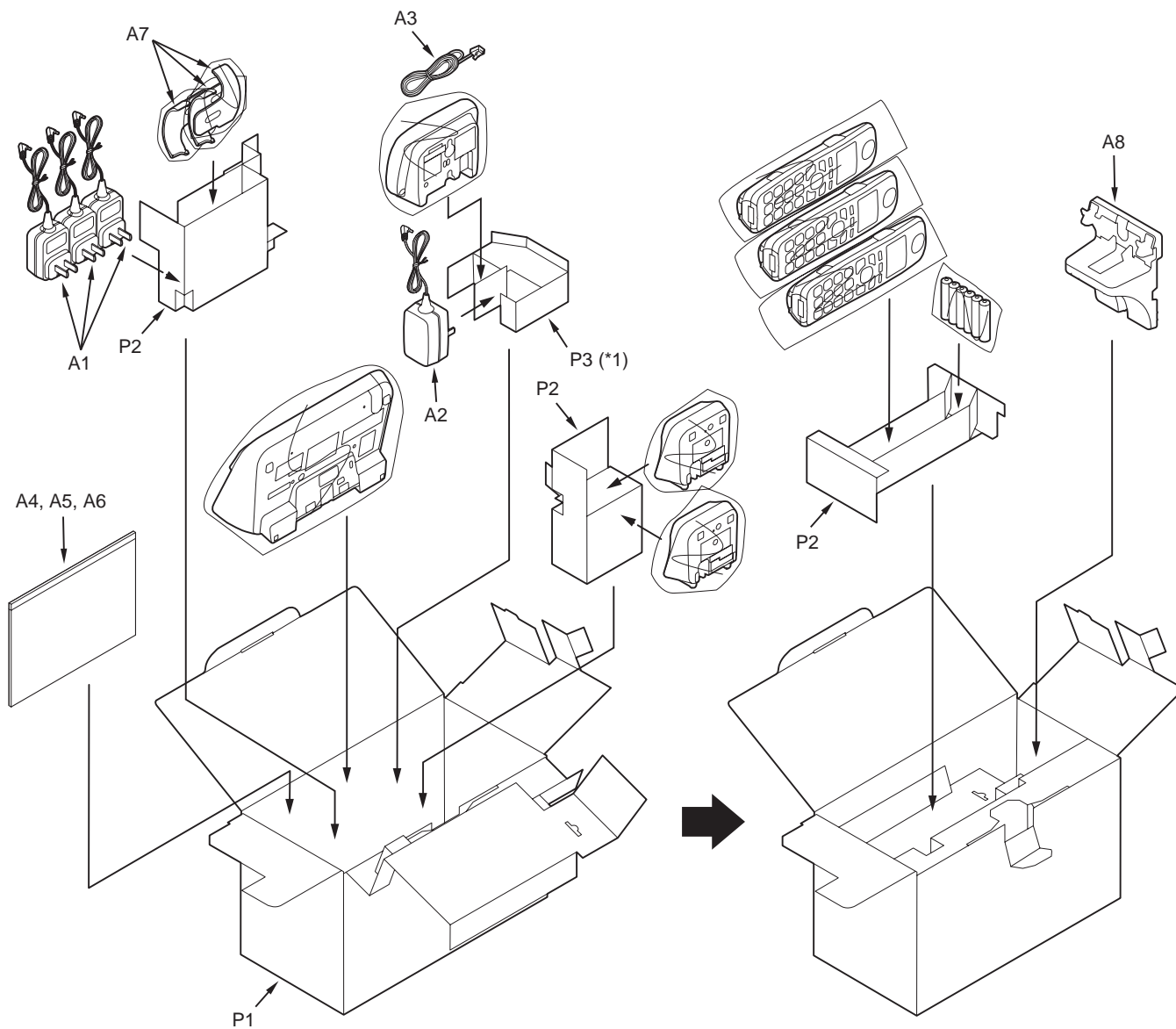

Note:
 (*1) This pad is a piece of Ref No.P1 (GIFT BOX).

16.5.2. KX-TGA470B

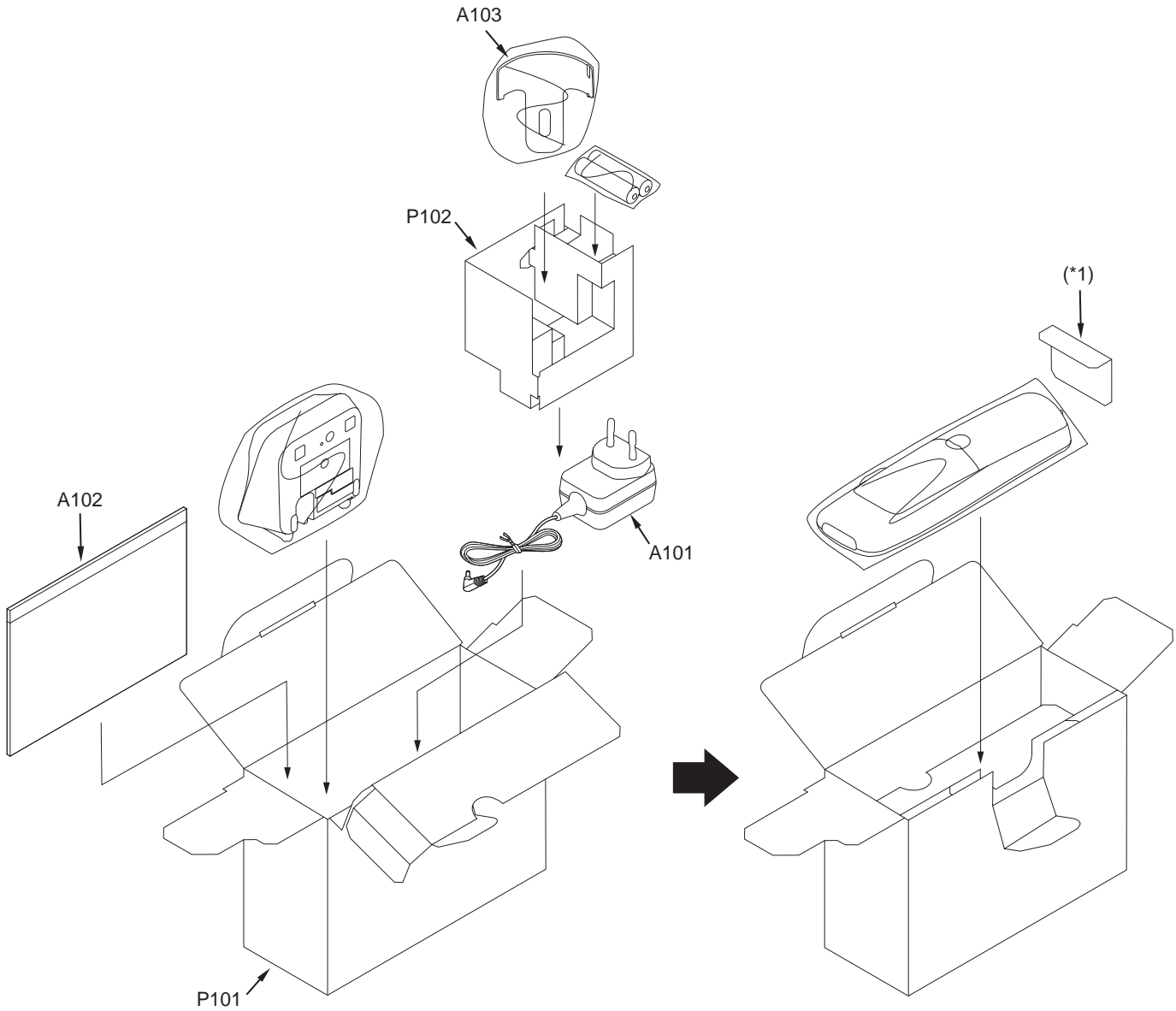

Note:
(*1) This pad is a piece of Ref No.P101 (GIFT BOX).

16.6. Replacement Parts List

1. RTL (Retention Time Limited)

Note:

The "RTL" marking indicates that its Retention Time is Limited.

When production is discontinued, this item will continue to be available only for a specific period of time.

This period of time depends on the type of item, and the local laws governing parts and product retention.

At the end of this period, the item will no longer be available.

2. Important safety notice

Components identified by the Δ mark indicates special characteristics important for safety. When replacing any of these components, only use specified manufacturer's parts.

3. The S mark means the part is one of some identical parts.

For that reason, it may be different from the installed part.

4. ISO code (Example: ABS-94HB) of the remarks column shows quality of the material and a flame resisting grade about plastics.

5. RESISTORS & CAPACITORS

Unless otherwise specified;

All resistors are in ohms (Ω) k=1000 Ω , M=1000k Ω

All capacitors are in MICRO FARADS (μ F) p= μ F

*Type & Wattage of Resistor

Type

ERC:Solid	ERX:Metal Film	PQ4R:Chip
ERDS:Carbon	ERG:Metal Oxide	ERS:Fusible Resistor
ERJ:Chip	ER0:Metal Film	ERF:Cement Resistor

Wattage

10,16:1/8W	14,25:1/4W	12:1/2W	1:1W	2:2W	3:3W
------------	------------	---------	------	------	------

*Type & Voltage Of Capacitor

Type

ECFD:Semi-Conductor	ECCD,ECKD,ECBT,F1K,ECUV: Ceramic
ECQS:Styrol	ECQE,ECQV,ECQG: Polyester
ECUV,PQCUV, ECUE:Chip	ECEA,ECST,EEE: Electlytic
ECQMS:Mica	ECQP: Polypropylene

Voltage

ECQ Type	ECQG ECQV Type	ECSZ Type	Others		
1H:50V	05:50V	0F:3.15V	0J :6.3V	1V :35V	
2A:100V	1:100V	1A:10V	1A :10V	50,1H:50V	
2E:250V	2:200V	1V:35V	1C :16V	1J :16V	
2H:500V		0J:6.3V	1E,25:25V	2A :100V	

16.6.1. Base Unit

16.6.1.1. Cabinet and Electrical Parts

Safety	Ref. No.	Part No.	Part Name & Description	Remarks
	1	PNGP1224Z1	PANEL, UPPER	PC-HB
	2	PNKM1255Z1	CABINET BODY	PS-HB
	3	L0AA04A00028	SPEAKER	
	4	PQHR11082Z	GUIDE, SPEAKER	POM-HB
	5	PNKE1130Z1	CASE, CHARGE TERMINAL	PS-HB
	6	PNJT1107Z	CHARGE TERMINAL	
	7	PNJK1145Z	KEYBOARD SWITCH, DIAL	
	8	PNBC1404Y3	BUTTON, NAVIGATOR KEY	ABS-HB
	9	PNHR1585Z	GUIDE, BUTTON	PS-HB
	10	PNBC1345Z1	BUTTON, MESSAGE	PMMA-HB
	11	PNJK1146Z	KEYBOARD SWITCH, TAM	
	12	PNLA1047Z	ANTENNA, SUB	
	13	PNLA1088Z	ANTENNA, SUB	

Safety	Ref. No.	Part No.	Part Name & Description	Remarks
	14	PQMG10025W	RUBBER PARTS, MIC	
	15	PNHR1584Z	GUIDE, JACK	PS-HB
	16	PQJJ1T039L	JACK, MODULAR	
	17	K2ECYZ000001	JACK, DC	
	18	PNKF1227Z1	CABINET COVER	PS-HB
	19	PNHA1013Z	RUBBER PARTS, FOOT CUSHION	
	20	PNGT6442Z	NAME PLATE	

16.6.1.2. Main P.C. Board Parts

Note:

(*1) When replacing IC611 or X501, make the adjustment using PNZZTG4741M. Refer to **How to download the data** (P.64) of Things to Do after Replacing IC or X'tal.

(*2) When replacing the base unit LCD, See **How to Replace the Base Unit LCD** (P.53).

Safety	Ref. No.	Part No.	Part Name & Description	Remarks
	PCB1	PNWP1TG4741H	MAIN P.C.BOARD ASS'Y (RTL)	
			(ICs)	
	IC302	C0DBEYY00102	IC	
	IC501	C2HBCY000107	IC (BBIC)	
	IC601	PNWI2TG4741H	IC (FLASH)	
	IC611	PNWI1TG4741H	IC (EEPROM) (*1)	
			(TRANSISTORS)	
	Q111	2SC6054JSL	TRANSISTOR (SI)	S
	Q141	B1ACGP000008	TRANSISTOR (SI)	
	Q142	B1ABDM000001	TRANSISTOR (SI)	
	Q161	DSC7003S0L	TRANSISTOR (SI)	
	Q171	2SC6054JSL	TRANSISTOR (SI)	S
	Q651	PSVTUMG11NTR	TRANSISTOR (SI)	S
	Q652	DRC9113Z0L	TRANSISTOR (SI)	
	Q653	2SC6054JSL	TRANSISTOR (SI)	S
	Q701	2SA1576S	TRANSISTOR (SI)	S
	Q702	B1GBCFFY0020	TRANSISTOR (SI)	
			(DIODES)	
	D101	PQVMD5S	DIODE (SI)	
	D113	DA2J10100L	DIODE (SI)	
	D133	DA2J10100L	DIODE (SI)	
	D142	PQVDPZT2530	DIODE (SI)	S
	D362	B0ECKM000008	DIODE (SI)	
	DA801	B0DDCD000001	DIODE (SI)	
	DA802	B0DDCD000001	DIODE (SI)	
			(COILS)	
	L501	G1CR10J00010	COIL	
	L809	G1C7N5JA0044	COIL	
			(RESISTOR ARRAYS)	
	RA151	D1H410220001	RESISTOR ARRAY	
	RA451	D1H422220001	RESISTOR ARRAY	
	RA452	D1H427220001	RESISTOR ARRAY	
	RA501	EXB28V330	RESISTOR ARRAY	
	RA502	EXB28V103	RESISTOR ARRAY	
	RA504	D1H468020001	RESISTOR ARRAY	
	RA651	EXB28V101JX	RESISTOR ARRAY	
	RA652	EXB28V101JX	RESISTOR ARRAY	
			(VARISTOR)	
	SA101	PQVDDSS301L	VARISTOR (SURGE ABSORBER)	S
			(RESISTORS)	
	R111	PQ4R10XJ104	100k	S
	R112	PQ4R10XJ104	100k	S
	R113	DOG103JA057	10k	
	R114	DOG473JA057	47k	
	R121	ERJ3GEYJ394	390k	S
	R122	ERJ3GEYJ394	390k	S
	R131	PQ4R18XJ106	10M	S
	R133	ERJ3GEYJ334	330k	S
	R136	DOG104JA021	100k	
	R141	DOG104JA057	100k	
	R142	PQ4R18XJ272	2.7k	S

Safety	Ref. No.	Part No.	Part Name & Description	Remarks
	R145	D0GA222JA021	2. 2k	
	R151	D0GA104JA021	100k	
	R152	ERJ2GEJ474X	470k	s
	R160	ERJ3GEYJ911	910	
	R161	D0GB104JA057	100k	
	R162	D0GB473JA057	47k	
	R163	ERJ14YJ120U	12	
	R164	D0GB272JA057	2. 7k	
	R165	ERJ3GEYJ273	27k	s
	R167	D0GG270JA007	27	
	R171	D0GA220JA021	22	
	R172	D0GA104JA021	100k	
	R175	D0GA561JA021	560	
	R176	D0GA101JA021	100	
	R177	D0GA102JA021	1k	
	R178	D0GA102JA021	1k	
	R321	ERJ2RKF1400	140	
	R322	ERJ2RKF1000	100	
	R331	ERJ3EKF6802	68k	
	R332	ERJ3EKF3302	33k	
	R371	ERJ14YJ1R0U	1	
	R372	ERJ14YJ1R0U	1	
	R373	D0GA182JA015	1. 8k	
	R451	ERJ2GEYJ391	390	s
	R501	D0GB100JA057	10	
	R502	D0GA330JA015	33	
	R505	D0GA222JA021	2. 2k	
	R605	D0GA332JA015	3. 3k	
	R606	D0GA332JA015	3. 3k	
	R612	D0GA103JA021	10k	
	R651	D0GA681JA021	680	
	R652	D0GA681JA021	680	
	R653	D0GA681JA021	680	
	R654	D0GA222JA021	2. 2k	
	R655	D0GA101JA021	100	
	R656	D0GA101JA021	100	
	R657	D0GA101JA021	100	
	R701	ERJ3GEYJ332	3. 3k	s
	R702	D0GA102JA021	1k	
	R703	D0GA102JA021	1k	
	R806	ERJ2GEJ471	470	s
	R807	ERJ2GEJ471	470	s
	R891	ERJ2GEJ471	470	s
	R892	ERJ2GEJ471	470	s
			(CAPACITORS)	
	C101	F1K2H681A008	680p	
	C102	F1K2H681A008	680p	
	C111	F1J2A473A024	0. 047	
	C112	F1J2A473A024	0. 047	
	C113	PQCUV1A684KB	0. 68	
	C120	ECUE1H102KBQ	0. 001	s
	C121	F1K2H681A008	680p	
	C122	F1K2H681A008	680p	
	C123	ECUE1H100DCQ	10p	s
	C124	ECUE1H100DCQ	10p	s
	C132	ECUV1H103KBV	0. 01	
	C142	ECUV1H103KBV	0. 01	
	C151	ECUE1H100DCQ	10p	s
	C152	ECUE1C103KBQ	0. 01	s
	C161	F1K1E1060001	10	
	C168	ECUV1A225KBV	2. 2	s
	C171	ECUV1H472KBV	0. 0047	
	C173	ECUV1A224KBV	0. 22	
	C175	ECUE1H102KBQ	0. 001	s
	C176	PQCUV0J106KB	10	s
	C178	ECUV1C223KBV	0. 022	
	C184	ECUV1A105KBV	1	
	C186	ECUE1H100DCQ	10p	s
	C321	ECUV1A105KBV	1	
	C341	F2G0J3310025	330	
	C342	ECUV1C104KBV	0. 1	
	C343	ECUE1H100DCQ	10p	s
	C351	ECUV1C105KBV	1	

Safety	Ref. No.	Part No.	Part Name & Description	Remarks
	C451	PQCUV0J106KB	10	s
	C452	ECUE1H100DCQ	10p	s
	C457	ECUE1C333KBQ	0. 033	s
	C458	ECUE1C333KBQ	0. 033	s
	C459	ECUE1H102KBQ	0. 001	s
	C476	ECUE1H100DCQ	10p	s
	C477	ECUE1H100DCQ	10p	s
	C478	ECUE1H100DCQ	10p	s
	C479	ECUE1H100DCQ	10p	s
	C501	ECUE1A104KBQ	0. 1	
	C502	ECJ1VB0G106M	10	s
	C503	ECJ1VB0G106M	10	s
	C504	ECUE0J105KBQ	1	
	C505	ECJ1VB0G106M	10	s
	C506	ECUV1A105KBV	1	
	C507	ECUV1A225KBV	2. 2	s
	C508	ECUE1H100DCQ	10p	s
	C509	ECUE1H120JQC	12p	s
	C510	ECUV1A105KBV	1	
	C511	ECJ1VB0G106M	10	s
	C512	ECUE1A104KBQ	0. 1	
	C513	ECUV1A225KBV	2. 2	s
	C514	ECUE1A104KBQ	0. 1	
	C515	ECUV1A105KBV	1	
	C516	ECUE1A104KBQ	0. 1	
	C517	ECUE1A104KBQ	0. 1	
	C518	ECUE1A104KBQ	0. 1	
	C519	ECUE1A104KBQ	0. 1	
	C520	ECUE1A104KBQ	0. 1	
	C521	ECUE0J105KBQ	1	
	C522	ECUE1H100DCQ	10p	s
	C530	ECUE1H100DCQ	10p	s
	C601	ECUE1A104KBQ	0. 1	
	C611	ECUE1A104KBQ	0. 1	
	C661	ECUE1A104KBQ	0. 1	
	C805	F1G1H2R7A480	2. 7p	
	C806	F1G1H2R7A480	2. 7p	
	C810	F1G1H2R4A480	2. 4p	
	C811	ECUE1H100DCQ	10p	s
	C812	F1G1HR90A480	0. 9p	
	C813	F1G1H2R0A480	2p	
	C820	F1G1H1R5A480	1. 5p	
	C822	ECUE1H100DCQ	10p	s
	C825	ECUE1H100DCQ	10p	s
	C826	ECUE1H100DCQ	10p	s
	C827	ECUE1H100DCQ	10p	s
	C859	F1G1H2R2A480	2. 2p	
	C863	F1G1H1R5A480	1. 5p	
	C891	F1G1H5R0A480	5p	
	C892	F1G1H5R0A480	5p	
	C893	ECUE1H100DCQ	10p	s
	C894	ECUE1H100DCQ	10p	s
	C895	F1G1H1R2A480	1. 2p	
	C896	F1G1H2R2A480	2. 2p	
			(OTHERS)	
	E1	L5DYBY00021	LIQUID CRYSTAL DISPLAY (*2)	
	E2	PNHX1406Z	COVER, LCD SHEET	
	E3	PNHR1386Z	GUIDE, LCD	ABS-HB
	P101	D4DAY220A022	THERMISTOR (POSISTOR)	
	F301	K5H302Y00003	FUSE	
	X501	H0J138500011	CRYSTAL OSCILLATOR (*1)	

16.6.1.3. Operational P.C. Board Parts

Safety	Ref. No.	Part No.	Part Name & Description	Remarks
	PCB2	PNWP2TG4741H	OPERATIONAL P.C. BOARD ASS'Y (RTL)	
			(LEDS)	
	LED901	B3AAB0000347	LED	
	LED902	B3AAB0000347	LED	
	LED904	B3AAB0000347	LED	

Safety	Ref. No.	Part No.	Part Name & Description	Remarks
	LED905	LNJ237W82RA	LED	
	LED906	LNJ237W82RA	LED	
	LED907	LNJ237W82RA	LED	
	LED908	LNJ237W82RA	LED	
			(RESISTORS)	
	R901	D0GA271JA015	270	
	R902	D0GA271JA015	270	
	R903	D0GA271JA015	270	
	R904	D0GA271JA015	270	
			(CAPACITORS)	
	C901	ECUV1C105KBV	1	
	C902	FLHLE1050001	1	
	C903	ECUE0J105KBQ	1	
	C910	ECUELH100DCQ	10p	S
			(OTHER)	
	MIC1	L0CBAY000018	MICROPHONE	

16.6.2. Handset

16.6.2.1. Cabinet and Electrical Parts

Safety	Ref. No.	Part No.	Part Name & Description	Remarks
	101	PNGP1228Z1	PANEL, LCD	PMMA-HB
	102	PNYE1066Z	TAPE, DOUBLE SIDED	
	103	PNKM1257Z1	CABINET BODY	ABS-HB
	104	PNGT6432Z	NAME PLATE	
	105	L0AD01A00026	RECEIVER	
	106	PNYE1065Y	SPACER, CUSHION LCD	
	107	PNBC1354Z1	BUTTON, NAVIGATOR KEY	ABS-HB
	108	PNJK1149Z	KEYBOARD SWITCH	
	109	PNJT1027Y	CHARGE TERMINAL (L)	
	110	PNJT1026Y	CHARGE TERMINAL (R)	
	111	PNJK1150Z	RUBBER PARTS, SIDE SWITCH	
	112	PQHR11315Z	GUIDE, SPEAKER	ABS-HB
	113	L0AA02A00096	SPEAKER	
	114	PQHS10784Y	SPACER, SPEAKER NET	
	115	PQJC10056W	BATTERY TERMINAL	
	116	PNKE1131Z1	COVER, EP CAP	
	117	PNKF1229Z1	CABINET COVER	ABS-HB
	118	PNHR1588Z	OPTIC CONDUCTIVE PARTS, LED LENS	PS-HB
	119	PNQT2006Z	LABEL, ATTENTION	
	120	PNQT2335Z	LABEL, BATTERY	
	121	PNHS1079Z	SPACER, BATTERY	
	122	PNKK1066Z1	LID, BATTERY	ABS-HB
	123	PNYNTGA470BR	LID, BATTERY ASS'Y	ABS-HB

16.6.2.2. Main P.C. Board Parts

Note:

(*1) Reconfirm the model No. written on the handset's name plate when replacing PCB100. Because the model No. of the optional handset may differ from the included handset.

(*2) When replacing IC3 or X1, make the adjustment using PNZZTG4741M. Refer to **Handset** (P.65) of Things to Do after Replacing IC or X'tal.

(*3) When replacing the handset LCD, See **How to Replace the Handset LCD** (P.55).

Safety	Ref. No.	Part No.	Part Name & Description	Remarks
	PCB100	PNWP1TGA470R	MAIN P.C.BOARD ASS'Y (RTL) (*1)	
			(ICs)	
	IC1	C2HBCY000081	IC	
	IC3	PNWITGA470BR	IC (EEPROM) (*2)	
	IC4	C0DBZYY00357	IC	
			(TRANSISTORS)	
	Q2	B1ADCF000040	TRANSISTOR(SI)	
	Q3	B1ABGE000011	TRANSISTOR(SI)	

Safety	Ref. No.	Part No.	Part Name & Description	Remarks
	Q4	B1ADCF000040	TRANSISTOR(SI)	
	Q5	DRC9113Z0L	TRANSISTOR(SI)	
	Q6	DRC9113Z0L	TRANSISTOR(SI)	
	Q9	2SC6054JSL	TRANSISTOR(SI)	S
			(DIODES)	
	D13	B0BC4R3A0006	DIODE(SI)	
	D14	B0BC4R3A0006	DIODE(SI)	
	D21	B0BC4R3A0006	DIODE(SI)	
	D22	B0BC4R3A0006	DIODE(SI)	
			(LEDS)	
	LED1	B3ACB0000190	LED	
	LED2	B3ACB0000190	LED	
	LED3	B3ACB0000190	LED	
	LED4	B3ACB0000190	LED	
	LED5	B3ACB0000190	LED	
	LED6	B3ACB0000190	LED	
	LED11	B3ACB0000190	LED	
	LED12	B3ACB0000190	LED	
			(COILS)	
	C812	PQLQR4C8N2J	COIL	S
	L4	G1CR18J00004	COIL	
			(RESISTOR ARRAYS)	
	RA2	D1H83314A013	RESISTOR ARRAY	S
	RA3	D1H83314A013	RESISTOR ARRAY	S
	RA4	D1H433220001	RESISTOR ARRAY	
	RA5	EXB28V332JX	RESISTOR ARRAY	
			(IC FILTERS)	
	L1	J0JCC0000286	IC FILTER	
	L3	J0JDC0000045	IC FILTER	
	L7	J0JCC0000276	IC FILTER	
	L10	J0JCC0000286	IC FILTER	
	L75	J0JCC0000286	IC FILTER	
			(SWITCHES)	
	VOL_DW	K0H1BB000094	TACTILE SWITCH	
	VOL_UP	K0H1BB000094	TACTILE SWITCH	
			(RESISTORS)	
	R2	ERJ2GEJ303	30k	
	R3	D0GA152JA021	1.5k	
	R4	D0GA473JA021	47k	
	R6	D0GA103JA021	10k	
	R7	D0GA104JA021	100k	
	R8	PQ4R18XJ3R3	3.3	S
	R9	ERJ2GEJ303	30k	
	R21	D0GA104JA021	100k	
	R22	D0GA332JA015	3.3k	
	R23	ERJ2GEYJ391	390	S
	R24	ERJ2GEJ100	10	S
	R25	D0GA222JA021	2.2k	
	R26	D0GA332JA015	3.3k	
	R27	D0GA222JA021	2.2k	
	R28	D0GA222JA021	2.2k	
	R31	ERJ2RKF1003	100k	
	R32	D0GA104JA021	100k	
	R33	ERJ2RKF1003	100k	
	R34	ERJ2GEYJ391	390	S
	R45	ERJ6RSJR10V	0.1	
	R50	D0GA151JA021	150	
	R51	D0GA151JA021	150	
	R60	D0GA222JA021	2.2k	
	R66	D0GA103JA021	10k	
	R67	D0GA103JA021	10k	
	R68	D0GA103JA021	10k	
	R69	D0GA103JA021	10k	
	R70	D0GA470JA021	47	
	R73	D0GA330JA015	33	
	R74	D0GA330JA015	33	
	R80	D0GA101JA021	100	
	R806	ERJ2GEJ471	470	S
	R807	ERJ2GEJ471	470	S
	L8	ERJ2GEJ100	10	S
	L9	ERJ2GE0R00	0	S
			(CAPACITORS)	
	C1	EEE0JA221WP	220	

Safety	Ref. No.	Part No.	Part Name & Description	Remarks
	C2	EEE0JA221WP	220	
	C3	EEE0JA221WP	220	
	C4	ECUE1H390JCQ	39p	
	C5	ECUE1A104KBQ	0.1	
	C6	ECUE1A104KBQ	0.1	
	C9	ECUE1H390JCQ	39p	
	C10	ECUE1H390JCQ	39p	
	C11	ECUE1A104KBQ	0.1	
	C12	PQCUV0J106KB	10	s
	C13	ECUE1A104KBQ	0.1	
	C14	ECUV1C393KBV	0.039	
	C15	ECUE1H390JCQ	39p	
	C16	F1J0J2260002	22	
	C17	ECUE1H100DCQ	10p	s
	C18	ECUE1H100DCQ	10p	s
	C20	ECJ1VB0G106M	10	s
	C21	ECUE0J105KBQ	1	
	C22	ECUE1A104KBQ	0.1	
	C23	ECUE1A104KBQ	0.1	
	C24	ECUE0J105KBQ	1	
	C25	ECUV1A225KBV	2.2	s
	C26	ECJ1VB0G106M	10	s
	C27	ECUE1H102KBQ	0.001	s
	C29	ECUV1A105KBV	1	
	C30	ECUV1A105KBV	1	
	C31	ECJ1VB0G106M	10	s
	C32	ECUE0J105KBQ	1	
	C33	ECUE1A104KBQ	0.1	
	C34	ECUE1H390JCQ	39p	
	C36	ECUE1A104KBQ	0.1	
	C37	ECJ1VB0G106M	10	s
	C39	ECUE1H102KBQ	0.001	s
	C40	ECUE1A104KBQ	0.1	
	C41	ECUE1A104KBQ	0.1	
	C42	ECUE1H102KBQ	0.001	s
	C43	ECUE1A104KBQ	0.1	
	C44	ECUE0J105KBQ	1	
	C45	ECUE1A104KBQ	0.1	
	C46	ECUE1H100DCQ	10p	s
	C51	ECJ1VB0G106M	10	s
	C52	ECUE1H100DCQ	10p	s
	C53	ECUE1H120JCQ	12p	s
	C56	ECUE0J105KBQ	1	
	C57	ECUE0J105KBQ	1	
	C58	ECUE0J105KBQ	1	
	C68	ECUE0J105KBQ	1	
	C69	ECUE1A104KBQ	0.1	
	C72	ECUE1H100DCQ	10p	s
	C73	ECUE1H100DCQ	10p	s
	C76	ECUE1H100DCQ	10p	s
	C77	ECUE1H100DCQ	10p	s
	C79	ECUE1H101JCQ	100p	
	C80	ECUV1C393KBV	0.039	
	C81	ECUE1H101JCQ	100p	
	C82	ECUE1H471KBQ	470p	s
	C83	ECUE1H100DCQ	10p	s
	C84	ECUE1H102KBQ	0.001	s
	C87	ECUE1H102KBQ	0.001	s
	C88	ECUE1H100DCQ	10p	s
	C89	ECUE1H100DCQ	10p	s
	C90	ECUE1A104KBQ	0.1	
	C91	ECUV1C105KBV	1	
	C92	ECUE0J105KBQ	1	
	C93	ECUV1C105KBV	1	
	C96	ECUE1H100DCQ	10p	s
	C97	ECUE1H100DCQ	10p	s
	C801	ECUV1H100DCV	10p	
	C802	F1G1H2R0A480	2p	
	C803	F1G1H1R3A480	1.3p	
	C804	F1G1H1R8A480	1.8p	
	C805	F1G1H2R4A480	2.4p	
	C806	F1G1H2R4A480	2.4p	
	C810	F1G1H2R5A480	2.5p	

Safety	Ref. No.	Part No.	Part Name & Description	Remarks
	C811	ECUE1H101JCQ	100p	s
	C813	F1G1H1R6A480	1.6p	
	C820	F1G1H1R8A480	1.8p	
	C822	ECUE1H100DCQ	10p	s
	C825	ECUE1H100DCQ	10p	s
	C826	ECUE1H100DCQ	10p	s
	C863	F1G1H1R8A480	1.8p	
	C897	F1G1H240A557	24p	
	L809	F1G1H1R0A480	1p	
			(OTHERS)	
	MIC100	L0CBAY000053	MICROPHONE	
	E101	L5DYBY00043	LIQUID CRYSTAL DISPLAY (*3)	
	E102	PNHX1569Z	COVER, DIFFUSION SHEET	
	E103	PNHX1518Z	COVER, LCD SHEET	
	E104	PNHR1587Z	TRANSPARENT PLATE, LCD	PMMA-HB
	E105	PNHR1586Z	GUIDE, LCD	ABS-HB
	E106	PQHG10729Z	RUBBER PARTS, RECEIVER	
	E107	PNVE1002Z	BATTERY TERMINAL	ABS-HB
	CN4	K2HD103D0001	JACK	
△	F1	K5H252Y00002	FUSE	
	X1	H0J138500003	CRYSTAL OSCILLATOR (*2)	s

16.6.3. LED Board Parts

Safety	Ref. No.	Part No.	Part Name & Description	Remarks
			(LED)	
	WLED	B3AFB0000370	LED	

16.6.4. Charger Unit

16.6.4.1. Cabinet and Electrical Parts

Safety	Ref. No.	Part No.	Part Name & Description	Remarks
	200	PNLC1029ZB	CHARGER UNIT ASS'Y without NAME PLATE (RTL)	
	200-1	PNKM1258Z1	CABINET BODY	PS-HB
	200-2	PNJT1105Z	CHARGE TERMINAL	
	200-3	PNKF1150Z1	CABINET COVER	PS-HB
	200-4	PQHA10023Z	RUBBER PARTS, FOOT CUSHION	
	201	PNGT6446Z	NAME PLATE	

16.6.4.2. Main P.C. Board Parts

Safety	Ref. No.	Part No.	Part Name & Description	Remarks
	PCB200	PNWPTGA470CH	MAIN P.C.BOARD ASS'Y (RTL)	
			(DIODE)	
	D1	B0ECKM000008	DIODE(SI)	
			(JACK)	
	J1	K2ECYB000001	JACK	
			(RESISTORS)	
	R1	ERJ14YJ1R0U	1	
	R2	ERJ14YJ1R0U	1	
			(FUSE)	
△	F1	K5H302Y00003	FUSE	

16.6.5. Range Extender

16.6.5.1. Cabinet and Electrical Parts

Safety	Ref. No.	Part No.	Part Name & Description	Remarks
	300	KX-TGA405B	RANGE EXTENDER UNIT ASS'Y without NAME PLATE (RTL) (for KX-TG4763B)	
	300-1	PNKM1136Z1	CABINET BODY	PS-HB
	300-2	PNKF1103Z1	CABINET COVER	PS-HB
	300-3	K2ECYZ000001	JACK	
	300-4	PNHR1267Z	OPTIC CONDUCTIVE PARTS	PS-HB
	300-5	PNLA1031Z	ANTENNA	
	301	PNGT4958Z	NAME PLATE	

16.6.5.2. Main P.C. Board Parts

Note:

(*1) When replacing IC611 or X501, make the adjustment using PNZZTG4741M.

Safety	Ref. No.	Part No.	Part Name & Description	Remarks
	PCB300	PNWPTGA405BR	MAIN P.C.BOARD ASS'Y (RTL) (ICs)	
	IC302	C0CBAYG00016	IC	S
	IC501	C2HBCY000046	IC	
	IC611	PNWITGA405BR	IC (*1) (TRANSISTORS)	
	Q651	B1GFCEFEN0011	TRANSISTOR(SI)	
	Q652	B1GFCEFEN0011	TRANSISTOR(SI) (DIODES)	
	DA801	B0DDCD000001	DIODE(SI)	
	DA802	B0DDCD000001	DIODE(SI) (LEDS)	
	LED651	LNJ237W82RA	LED	
	LED652	LNJ308G8JRA	LED	
	LED653	LNJ237W82RA	LED	
	LED654	LNJ308G8JRA	LED (COIL)	
	L809	G1C7N5JA0044	COIL (FUSE)	
△	F301	K5H302Y00003	FUSE (RESISTOR ARRAYS)	
	RA501	EXB28V330	RESISTOR ARRAY	
	RA502	EXB28V103	RESISTOR ARRAY	
	RA504	D1H468020001	RESISTOR ARRAY (RESISTORS)	
	R321	ERJ2RKF1400	140	
	R322	ERJ2RKF1000	100	
	R501	ERJ3GEY0R00	0	S
	R502	D0GA330JA015	33	
	R505	D0GA222JA021	2.2k	
	R605	D0GA332JA015	3.3k	
	R606	D0GA332JA015	3.3k	
	R612	D0GA103JA021	10k	
	R651	ERJ3GEYJ681	680	S
	R652	ERJ3GEYJ101	100	S
	R653	ERJ3GEYJ681	680	S
	R654	ERJ3GEYJ101	100	S
	R661	D0GA102JA021	1k	
	R662	ERJ2GE0R00	0	S
	R806	ERJ2GEJ471	470	S
	R807	ERJ2GEJ471	470	S
	R891	ERJ2GEJ471	470	S
	R892	ERJ2GEJ471	470	S
	JJ301	PQ4R10XJ000	0 (CAPACITORS)	S
	C321	ECUV1A105KBV	1	
	C341	F2G0J3310015	330	
	C342	ECUV1C104KBV	0.1	

Safety	Ref. No.	Part No.	Part Name & Description	Remarks
	C501	ECUE1A104KBQ	0.1	
	C502	ECJ1VB0G106M	10	
	C503	ECUV1C104KBV	0.1	
	C504	ECUE1C103KBQ	0.01	S
	C508	ECUE1H100DCQ	10p	S
	C509	ECUE1H120JQC	12p	S
	C510	ECUV1A105KBV	1	
	C511	ECJ1VB0G106M	10	
	C512	ECUE1A104KBQ	0.1	
	C513	ECUV1A225KBV	2.2	S
	C514	ECUE1A104KBQ	0.1	
	C515	ECUV1A105KBV	1	
	C516	ECUE1A104KBQ	0.1	
	C517	ECUE1A104KBQ	0.1	
	C518	ECUE1A104KBQ	0.1	
	C519	ECUE1A104KBQ	0.1	
	C520	ECUE1A104KBQ	0.1	
	C530	ECUE1H100DCQ	10p	S
	C611	ECUE1A104KBQ	0.1	
	C805	F1G1H2R7A480	2.7p	
	C806	F1G1H2R7A480	2.7p	
	C810	F1G1H2R4A480	2.4p	
	C811	ECUE1H100DCQ	10p	S
	C812	F1G1HR90A480	0.9p	
	C813	F1G1H2R0A480	2p	
	C820	F1G1H1R5A480	1.5p	
	C822	ECUE1H100DCQ	10p	S
	C825	ECUE1H100DCQ	10p	S
	C826	ECUE1H100DCQ	10p	S
	C827	ECUE1H100DCQ	10p	S
	C859	F1G1H2R2A480	2.2p	
	C863	F1G1H1R5A480	1.5p	
	C891	F1G1H5R0A480	5p	
	C892	F1G1H5R0A480	5p	
	C893	ECUE1H100DCQ	10p	S
	C894	ECUE1H100DCQ	10p	S
	C895	F1G1H1R2A480	1.2p	
	C896	F1G1H2R2A480	2.2p (OTHERS)	
	SW1	K0H1BA000259	SPECIAL SWITCH	
	X501	HOJ138500011	CRYSTAL OSCILLATOR (*1)	

16.6.6. Accessories and Packing Materials

Note:

(*1) You can download and refer to the Operating Instructions (Instruction book) on TSN Server.

16.6.6.1. KX-TG4763B

Safety	Ref. No.	Part No.	Part Name & Description	Remarks
△	A1	PNLV226Z	AC ADAPTOR	
△	A2	PQLV219Y	AC ADAPTOR (for RANGE EXTENDER)	S
	A3	PQJA10075Z	CORD, TELEPHONE	
	A4	PNQX5092Z	INSTRUCTION BOOK (*1)	
	A5	PNQW1965Y	LEAFLET, RANGE EXTENDER (for ENGLISH)	
	A6	PNQW2213Y	LEAFLET, RANGE EXTENDER (for SPANISH)	
	A7	PNKE1132Z1	HANGER, BELT CLIP	ABS-HB
	A8	PNKL1001Y1	STAND, WALL MOUNT	ABS-HB
	P1	PNPK3489001Z	GIFT BOX	
	P2	PNPD1596Z	CUSHION	
	P3	PNPD1654Z	CUSHION (TG4763 with carton)	

16.6.6.2. KX-TGA470B

Safety	Ref. No.	Part No.	Part Name & Description	Remarks
△	A101	PNLV226Z	AC ADAPTOR	

Safety	Ref. No.	Part No.	Part Name & Description	Remarks
	A102	PNQX5093Z	INSTRUCTION BOOK (*1)	
	A103	PNKE1132Z1	HANGER, BELT CLIP	ABS-HB
	P101	PNPK3490001Z	GIFT BOX	
	P102	PNPD1648Z	CUSHION	

16.6.7. Screws

Safety	Ref. No.	Part No.	Part Name & Description	Remarks
	A	XTB26+8GFJ	TAPPING SCREW	
	B	XTB2+8GFJ	TAPPING SCREW	

16.6.8. Fixtures and Tools

Note:

(*1) See **Equipment Required** (P.56), and **The Setting Method of JIG** (P.56)

(*2) When replacing the Handset LCD, See **How to Replace the Handset LCD** (P.55)

Safety	Ref. No.	Part No.	Part Name & Description	Remarks
		PQZZ1CD300E	JIG CABLE (*1)	
		PNZZTG4741M	BATCH FILE CD-ROM (*1)	
		PQZZ430PIR	TIP OF SOLDERING IRON (*2)	
		PQZZ430PRB	RUBBER OF SOLDERING IRON (*2)	

Service Manual

Telephone Equipment

Model No. **KX-TG4763B**
KX-TGA470B
KX-TGA405B

Digital Cordless Answering System

B: Black Version
 (for U.S.A.)

Supplement-1

Please file and use this supplement manual together with the service manual for Model No. KX-TG4763B/ KX-TGA470B/KX-TGA405B, Order No. KM41201528CE.

WARNING

This service information is designed for experienced repair technicians only and is not designed for use by the general public. It does not contain warnings or cautions to advise non-technical individuals of potential dangers in attempting to service a product. Products powered by electricity should be serviced or repaired only by experienced professional technicians. Any attempt to service or repair the product or products dealt with in this service information by anyone else could result in serious injury or death.









TABLE OF CONTENTS

	PAGE
1 REPLACEMENT PARTS LIST -----	2
1.1. REFERENCE CHART-----	2
1.2. ORIGINAL AND NEW PARTS COMPARISON LISTS-----	2

1 REPLACEMENT PARTS LIST

1.1. REFERENCE CHART

Reason for Change	
*The following items (1-8) indicate the reason for change. See the "Notes" column for each part in ORIGINAL AND NEW PARTS COMPARISON LISTS .	
1. Improve performance	Remarks: *c: To share the parts with other models
2. Change of material or dimension	
3. To meet approved specification	
4. Standardization	
5. Addition	
6. Deletion	
7. Correction	
8. Other	

Interchangeability Code		
**The following items (V-Z) indicate the Interchangeability. See the "Notes" column for each part in ORIGINAL AND NEW PARTS COMPARISON LISTS .		
V	Original  Early (before change) New  Late (after change)	Original or new parts may be used in early or late production sets. Use original parts until exhausted, then stock new parts.
W	Original  Early (before change) New  Late (after change)	Original parts may be used in early production sets only. New parts may be used in early or late production sets. Use original parts where possible, then stock new parts.
X	Original  Early (before change) New  Late (after change)	New parts only may be used in early or late production sets. Stock new parts.
Y	Original  Early (before change) New  Late (after change)	Original parts may be used in early production sets only. New parts may be used in late production sets only. Stock both original and new parts.
Z	Other	

Note:

Alphabets in the "Remarks" column in the following lists correspond to the alphabets in the "Remarks" in REFERENCE CHART.

1.2. ORIGINAL AND NEW PARTS COMPARISON LISTS

Ref. No.	Part No.		Part Name & Description	Pcs/ Set	Remarks	Notes	Time of Change (Suffix)
	Original (Old)	New					
Main P.C.Board Parts (Handset)							
C1	EEE0JA221WP	-----	CAPACITOR, 220 μ F	0	*c	6 V	---
C3	EEE0JA221WP	-----	CAPACITOR, 220 μ F	0	*c	6 V	---

Service Manual

Telephone Equipment

Model No. **KX-TG4763B**
KX-TGA470B
KX-TGA405B

Digital Cordless Answering System

B: Black Version
 (for U.S.A.)

Supplement-2

Please file and use this supplement manual together with the service manual for Model No. KX-TG4763B/ KX-TGA470B/KX-TGA405B, Order No. KM41201528CE.

WARNING

This service information is designed for experienced repair technicians only and is not designed for use by the general public. It does not contain warnings or cautions to advise non-technical individuals of potential dangers in attempting to service a product. Products powered by electricity should be serviced or repaired only by experienced professional technicians. Any attempt to service or repair the product or products dealt with in this service information by anyone else could result in serious injury or death.









TABLE OF CONTENTS

	PAGE
1 REPLACEMENT PARTS LIST -----	2
1.1. REFERENCE CHART-----	2
1.2. ORIGINAL AND NEW PARTS COMPARISON LISTS-----	2

1 REPLACEMENT PARTS LIST

1.1. REFERENCE CHART

Reason for Change	
*The following items (1-8) indicate the reason for change. See the "Notes" column for each part in ORIGINAL AND NEW PARTS COMPARISON LISTS .	
1. Improve performance	Remarks: *j : To meet the standards.
2. Change of material or dimension	
3. To meet approved specification	
4. Standardization	
5. Addition	
6. Deletion	
7. Correction	
8. Other	

Interchangeability Code		
**The following items (V-Z) indicate the Interchangeability. See the "Notes" column for each part in ORIGINAL AND NEW PARTS COMPARISON LISTS .		
V	Original  Early (before change) New  Late (after change)	Original or new parts may be used in early or late production sets. Use original parts until exhausted, then stock new parts.
W	Original  Early (before change) New  Late (after change)	Original parts may be used in early production sets only. New parts may be used in early or late production sets. Use original parts where possible, then stock new parts.
X	Original  Early (before change) New  Late (after change)	New parts only may be used in early or late production sets. Stock new parts.
Y	Original  Early (before change) New  Late (after change)	Original parts may be used in early production sets only. New parts may be used in late production sets only. Stock both original and new parts.
Z	Other	

Note:

Alphabets in the "Remarks" column in the following lists correspond to the alphabets in the "Remarks" in REFERENCE CHART.

1.2. ORIGINAL AND NEW PARTS COMPARISON LISTS

Ref. No.	Part No.		Part Name & Description	Pcs/ Set	Remarks	Notes	Time of Change (Suffix)
	Original (Old)	New					
Cabinet and Electrical Parts (Handset)							
104	PNGT6432Z	PNGT7243Z	NAME PLATE (Made in China)	1	*j	4 Y	---

NM
KXTG4763B
KXTGA470B
KXTGA405B

Service Manual

Telephone Equipment

Model No. **KX-TG4763B**
KX-TGA470B
KX-TGA405B

Digital Cordless Answering System

B: Black Version
(for U.S.A.)

Supplement-3

Please file and use this supplement manual together with the service manual for Model No.KX-TG4763B/
KX-TGA470B/KX-TGA405B,Order No. KM41201528CE.

WARNING

This service information is designed for experienced repair technicians only and is not designed for use by the general public. It does not contain warnings or cautions to advise non-technical individuals of potential dangers in attempting to service a product. Products powered by electricity should be serviced or repaired only by experienced professional technicians. Any attempt to service or repair the product or products dealt with in this service information by anyone else could result in serious injury or death.









TABLE OF CONTENTS

	PAGE
1 REPLACEMENT PARTS LIST -----	2
1.1. REFERENCE CHART-----	2
1.2. ORIGINAL AND NEW PARTS COMPARISON LISTS-----	2

1 REPLACEMENT PARTS LIST

1.1. REFERENCE CHART

Reason for Change	
*The following items (1-8) indicate the reason for change. See the "Notes" column for each part in ORIGINAL AND NEW PARTS COMPARISON LISTS .	
1. Improve performance	Remarks: *m: Discontinued (To be replaced with a new part)
2. Change of material or dimension	
3. To meet approved specification	
4. Standardization	
5. Addition	
6. Deletion	
7. Correction	
8. Other	

Interchangeability Code		
**The following items (V-Z) indicate the Interchangeability. See the "Notes" column for each part in ORIGINAL AND NEW PARTS COMPARISON LISTS .		
V	Original  Early (before change) New  Late (after change)	Original or new parts may be used in early or late production sets. Use original parts until exhausted, then stock new parts.
W	Original  Early (before change) New  Late (after change)	Original parts may be used in early production sets only. New parts may be used in early or late production sets. Use original parts where possible, then stock new parts.
X	Original  Early (before change) New  Late (after change)	New parts only may be used in early or late production sets. Stock new parts.
Y	Original  Early (before change) New  Late (after change)	Original parts may be used in early production sets only. New parts may be used in late production sets only. Stock both original and new parts.
Z	Other	

Note:

Alphabets in the "Remarks" column in the following lists correspond to the alphabets in the "Remarks" in REFERENCE CHART.

1.2. ORIGINAL AND NEW PARTS COMPARISON LISTS

Ref. No.	Part No.		Part Name & Description	Pcs/ Set	Remarks	Notes	Time of Change (Suffix)
	Original (Old)	New					
Cabinet and Electrical Parts (Base Unit)							
20	PNGT6442Z	PNGT7658Z	NAME PLATE	1	*m	8 V	---