

Service Manual

High Definition Video Camera

AVCHD™

DOLBY
DIGITAL
STEREO CREATOR

SD
XC

HDMI VIERA Link™

Model No. **HDC-SD40P**

HDC-SD40PC

HDC-SD40PU

HDC-SD40EB

HDC-SD40EC

HDC-SD40EE

HDC-SD40EF

HDC-SD40EG

HDC-SD40EP

HDC-SD40GA

HDC-SD40GC

HDC-SD40GK

HDC-SD40GN

HDC-SD40GW

HDC-SD41EB

HDC-TM40P

HDC-TM40PC

HDC-TM40PU

HDC-TM40EB

HDC-TM40GD

HDC-TM40GK

HDC-TM41P

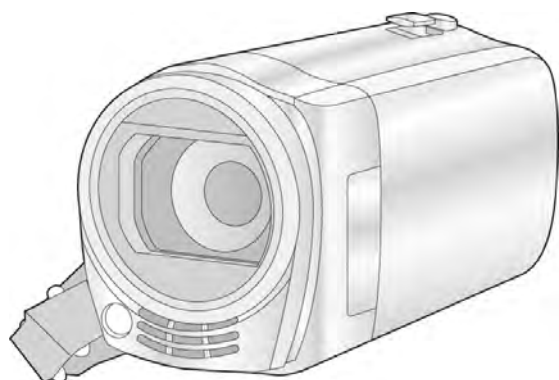

Panasonic®

© Panasonic Corporation 2011 Unauthorized copying and distribution is a violation of law.

Vol. 1

Colour

[HDC-SD40]

(K).....Black Type

(W).....White Type (only EB/EC/EE/EF/EG/EP)

[HDC-SD41]

(H).....Glaz Type

[HDC-TM40]

(K).....Black Type

[HDC-TM41]

(H).....Glaz Type

WARNING

This service information is designed for experienced repair technicians only and is not designed for use by the general public. It does not contain warnings or cautions to advise non-technical individuals of potential dangers in attempting to service a product. Products powered by electricity should be serviced or repaired only by experienced professional technicians. Any attempt to service or repair the product or products dealt with in this service information by anyone else could result in serious injury or death.

TABLE OF CONTENTS

	PAGE	PAGE
1 Safety Precautions	3	
1.1. General Guidelines	3	
1.2. Leakage Current Cold Check	3	
1.3. Leakage Current Hot Check (See Figure 1.)	3	
2 Warning	4	
2.1. Prevention of Electrostatic Discharge (ESD) to Electrostatically Sensitive (ES) Devices	4	
2.2. How to Recycle the Lithium Ion Battery (U.S. Only)	4	
2.3. Caution for AC Cord (For EB/GC)	5	
2.4. How to Replace the Lithium Battery	6	
3 Service Navigation	7	
3.1. Introduction	7	
3.2. General Description About Lead Free Solder (PbF)	7	
3.3. Important Notice 1	7	
3.4. How to Define the Model Suffix (NTSC or PAL model)	8	
3.5. Formatting	9	
4 Specifications	10	
5 Location of Controls and Components	12	
6 Service Fixture & Tools	14	
6.1. When Replacing the Main P.C.B.	14	
6.2. Service Position	14	
7 Disassembly and Assembly Instructions	15	
7.1. Disassembly Flow Chart	15	
7.2. PCB Location	15	
7.3. Disassembly Procedure	15	
8 Measurements and Adjustments	22	
8.1. Electric Adjustment	22	
9 Factory Setting	24	
9.1. How To Turn On The Factory Settings?	24	
9.2. What Is The Factory Settings?	24	

1 Safety Precautions

1.1. General Guidelines

1. IMPORTANT SAFETY NOTICE

There are special components used in this equipment which are important for safety. These parts are marked by

 in the Schematic Diagrams, Circuit Board Layout, Exploded Views and Replacement Parts List. It is essential that these critical parts should be replaced with manufacturer's specified parts to prevent X-RADIATION, shock, fire, or other hazards. Do not modify the original design without permission of manufacturer.

2. An Isolation Transformer should always be used during the servicing of AC Adaptor whose chassis is not isolated from the AC power line. Use a transformer of adequate power rating as this protects the technician from accidents resulting in personal injury from electrical shocks. It will also protect AC Adaptor from being damaged by accidental shorting that may occur during servicing.
3. When servicing, observe the original lead dress. If a short circuit is found, replace all parts which have been overheated or damaged by the short circuit.
4. After servicing, see to it that all the protective devices such as insulation barriers, insulation papers shields are properly installed.
5. After servicing, make the following leakage current checks to prevent the customer from being exposed to shock hazards.

1.2. Leakage Current Cold Check

1. Unplug the AC cord and connect a jumper between the two prongs on the plug.
2. Measure the resistance value, with an ohmmeter, between the jumpered AC plug and each exposed metallic cabinet part on the equipment such as screwheads, connectors, control shafts, etc. When the exposed metallic part has a return path to the chassis, the reading should be between $1\text{ M}\Omega$ and $5.2\text{ M}\Omega$. When the exposed metal does not have a return path to the chassis, the reading must be infinity.

1.3. Leakage Current Hot Check (See Figure 1.)

1. Plug the AC cord directly into the AC outlet. Do not use an isolation transformer for this check.
2. Connect a $1.5\text{ k}\Omega$, 10 W resistor, in parallel with a $0.15\text{ }\mu\text{F}$ capacitor, between each exposed metallic part on the set and a good earth ground, as shown in Figure 1.
3. Use an AC voltmeter, with $1\text{ k}\Omega/\text{V}$ or more sensitivity, to measure the potential across the resistor.
4. Check each exposed metallic part, and measure the voltage at each point.
5. Reverse the AC plug in the AC outlet and repeat each of the above measurements.
6. The potential at any point should not exceed 0.75 V RMS . A leakage current tester (Simpson Model 229 or equivalent) may be used to make the hot checks, leakage current must not exceed $1/2\text{ mA}$. In case a measurement is outside of the limits specified, there is a possibility of a shock hazard, and the equipment should be repaired and rechecked before it is returned to the customer.

Hot-Check Circuit

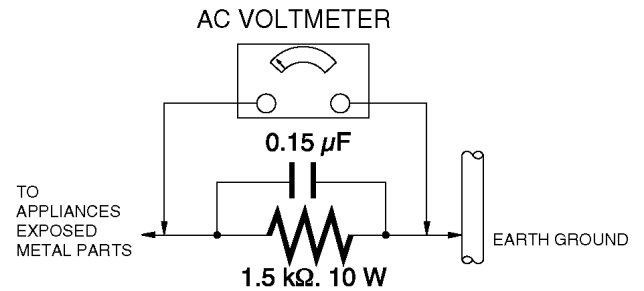

Figure. 1

2 Warning

2.1. Prevention of Electrostatic Discharge (ESD) to Electrostatically Sensitive (ES) Devices

Some semiconductor (solid state) devices can be damaged easily by static electricity. Such components commonly are called Electrostatically Sensitive (ES) Devices. Examples of typical ES devices are integrated circuits and some field-effect transistors and semiconductor "chip" components. The following techniques should be used to help reduce the incidence of component damage caused by electrostatic discharge (ESD).

1. Immediately before handling any semiconductor component or semiconductor-equipped assembly, drain off any ESD on your body by touching a known earth ground. Alternatively, obtain and wear a commercially available discharging ESD wrist strap, which should be removed for potential shock reasons prior to applying power to the unit under test.
2. After removing an electrical assembly equipped with ES devices, place the assembly on a conductive surface such as aluminum foil, to prevent electrostatic charge buildup or exposure of the assembly.
3. Use only a grounded-tip soldering iron to solder or unsolder ES devices.
4. Use only an antistatic solder removal device. Some solder removal devices not classified as "antistatic (ESD protected)" can generate electrical charge sufficient to damage ES devices.
5. Do not use freon-propelled chemicals. These can generate electrical charges sufficient to damage ES devices.
6. Do not remove a replacement ES device from its protective package until immediately before you are ready to install it. (Most replacement ES devices are packaged with leads electrically shorted together by conductive foam, aluminum foil or comparable conductive material).
7. Immediately before removing the protective material from the leads of a replacement ES device, touch the protective material to the chassis or circuit assembly into which the device will be installed.

CAUTION :

Be sure no power is applied to the chassis or circuit, and observe all other safety precautions.

8. Minimize bodily motions when handling unpackaged replacement ES devices. (Otherwise harmless motion such as the brushing together of your clothes fabric or the lifting of your foot from a carpeted floor can generate static electricity (ESD) sufficient to damage an ES device).

2.2. How to Recycle the Lithium Ion Battery (U.S. Only)

ENGLISH



A lithium ion/polymer battery that is recyclable powers the product you have purchased. Please call 1-800-8-BATTERY for information on how to recycle this battery.

FRANÇAIS



L'appareil que vous vous êtes procuré est alimenté par une batterie au lithium-ion/lithium-polymère. Pour des renseignements sur le recyclage de la batterie, veuillez composer le 1-800-8-BATTERY.

2.3. Caution for AC Cord (For EB/GC)

2.3.1. Information for Your Safety

IMPORTANT

Your attention is drawn to the fact that recording of pre-recorded tapes or discs or other published or broadcast material may infringe copyright laws.

WARNING

To reduce the risk of fire or shock hazard, do not expose this equipment to rain or moisture.

CAUTION

To reduce the risk of fire or shock hazard and annoying interference, use the recommended accessories only.

FOR YOUR SAFETY

DO NOT REMOVE THE OUTER COVER

To prevent electric shock, do not remove the cover. No user serviceable parts inside. Refer servicing to qualified service personnel.

2.3.2. Caution for AC Mains Lead

For your safety, please read the following text carefully.

This appliance is supplied with a moulded three-pin mains plug for your safety and convenience.

A 5-ampere fuse is fitted in this plug.

Should the fuse need to be replaced please ensure that the replacement fuse has a rating of 5 amperes and it is approved by ASTA or BSI to BS1362

Check for the ASTA mark or the BSI mark on the body of the fuse.



If the plug contains a removable fuse cover you must ensure that it is refitted when the fuse is replaced.

If you lose the fuse cover, the plug must not be used until a replacement cover is obtained.

A replacement fuse cover can be purchased from your local Panasonic Dealer.

If the fitted moulded plug is unsuitable for the socket outlet in your home then the fuse should be removed and the plug cut off and disposed of safely.

There is a danger of severe electrical shock if the cut off plug is inserted into any 13-ampere socket.

If a new plug is to be fitted please observe the wiring code as shown below.

If in any doubt, please consult a qualified electrician.

2.3.2.1. Important

The wires in this mains lead are coloured in accordance with the following code:

Blue	Neutral
Brown	Live

As the colours of the wires in the mains lead of this appliance may not correspond with the coloured markings identifying the terminals in your plug, proceed as follows:

The wire which is coloured BLUE must be connected to the terminal in the plug which is marked with the letter N or coloured BLACK.

The wire which is coloured BROWN must be connected to the terminal in the plug which is marked with the letter L or coloured RED.

Under no circumstances should either of these wires be connected to the earth terminal of the three pin plug, marked with the letter E or the Earth Symbol.



2.3.2.2. Before Use

Remove the Connector Cover as follows.

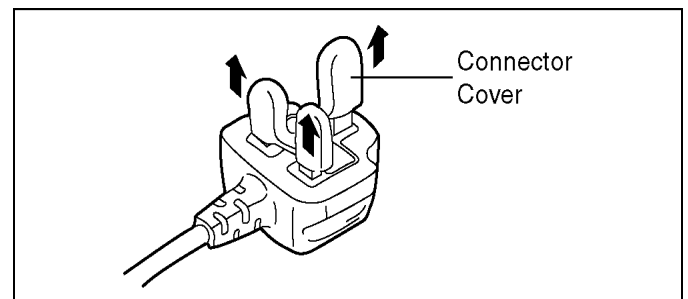

2.3.2.3. How to Replace the Fuse

1. Remove the Fuse Cover with a screwdriver.

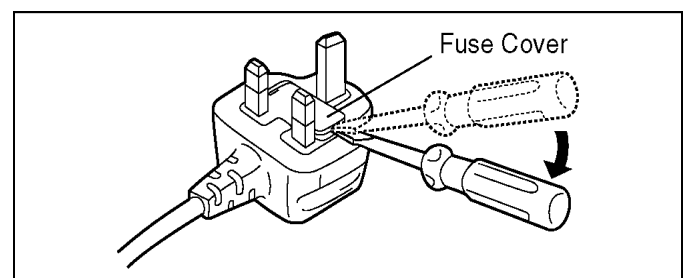

2. Replace the fuse and attach the Fuse cover.

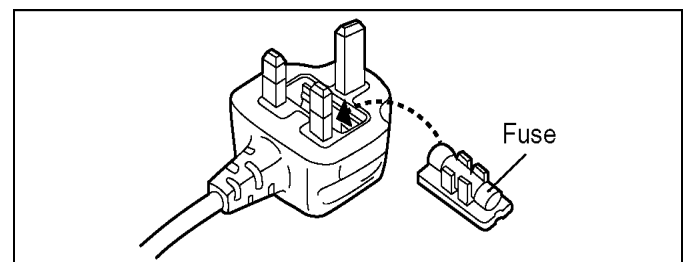

2.4. How to Replace the Lithium Battery

2.4.1. Replacement Procedure

1. Remove the SD Holder P.C.B.. (Refer to Disassembly Procedures.)
2. Unsolder the each soldering point of electric lead terminal for Lithium battery (Ref. No. "B6401" at foil side of SD HOLDER P.C.B.) and remove the Lithium battery together with electric lead terminal. Then replace it into new one.

NOTE:

The Type No. ML-614S/DN includes electric lead terminals.

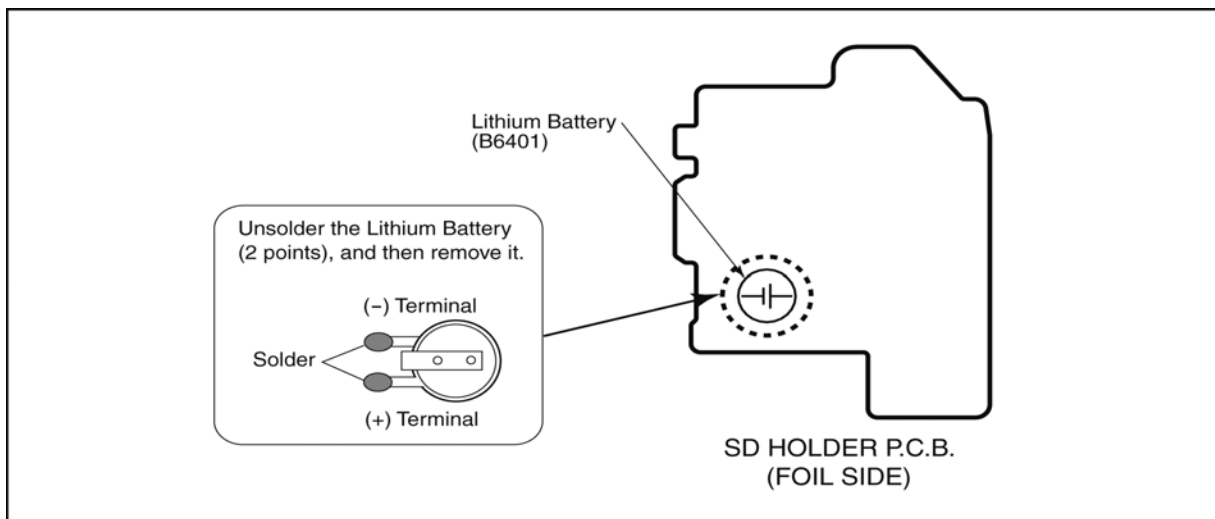

NOTE:

This Lithium battery is a critical component.

(Type No.: ML-614S/DN **Manufactured by Energy Company, Panasonic Corporation**)

It must never be subjected to excessive heat or discharge.

It must therefore only be fitted in requirement designed specifically for its use.

Replacement batteries must be of same type and manufacture.

They must be fitted in the same manner and location as the original battery, with the correct polarity contacts observed.

Do not attempt to re-charge the old battery or re-use it for any other purpose.

It should be disposed of in waste products destined for burial rather than incineration.

(For English)

CAUTION

Danger of explosion if battery is incorrectly replaced.

Replace only with the same or equivalent type recommended by the manufacturer.

Dispose of used batteries according to the manufacturer's instructions.

(For German)

ACHTUNG

Explosionsgefahr bei falschem Anbringen der Batterie. Ersetzen Sie nur mit einem äquivalentem vom Hersteller empfohlenem Typ.

Behandeln Sie gebrauchte Batterien nach den Anweisungen des Herstellers.

(For French)

MISE EN GARDE

Une batterie de remplacement inappropriée peut exploser. Ne remplacez qu'avec une batterie identique ou d'un type recommandé par le fabricant. L'élimination des batteries usées doit être faite conformément aux instructions du fabricant.

NOTE:

Above caution is applicable for a battery pack which is for HDC-SD40/SD41/TM40/TM41 series, as well.

3 Service Navigation

3.1. Introduction

This service manual contains technical information, which allow service personnel's to understand and service this model.

Please place orders using the parts list and not the drawing reference numbers.

If the circuit is changed or modified, the information will be followed by service manual to be controlled with original service manual.

3.2. General Description About Lead Free Solder (PbF)

The lead free solder has been used in the mounting process of all electrical components on the printed circuit boards used for this equipment in considering the globally environmental conservation.

The normal solder is the alloy of tin (Sn) and lead (Pb). On the other hand, the lead free solder is the alloy mainly consists of tin (Sn), silver (Ag) and Copper (Cu), and the melting point of the lead free solder is higher approx.30°C (86°F) more than that of the normal solder.

Distinction of P.C.B. Lead Free Solder being used

The letter of "PbF" is printed either foil side or components side on the P.C.B. using the lead free solder.(See right figure)	PbF
--------------------------------------------------------------------------------------------------------------------------------	------------

Service caution for repair work using Lead Free Solder (PbF)

- The lead free solder has to be used when repairing the equipment for which the lead free solder is used.
(Definition: The letter of "PbF" is printed on the P.C.B. using the lead free solder.)
- To put lead free solder, it should be well molten and mixed with the original lead free solder.
- Remove the remaining lead free solder on the P.C.B. cleanly for soldering of the new IC.
- Since the melting point of the lead free solder is higher than that of the normal lead solder, it takes the longer time to melt the lead free solder.
- Use the soldering iron (more than 70W) equipped with the temperature control after setting the temperature at 350±30°C (662±86°F).

Recommended Lead Free Solder (Service Parts Route.)

- The following 3 types of lead free solder are available through the service parts route.
RFKZ03D01KS----- (0.3mm 100g Reel)
RFKZ06D01KS----- (0.6mm 100g Reel)
RFKZ10D01KS----- (1.0mm 100g Reel)

Note

* Ingredient: tin (Sn) 96.5%, silver (Ag) 3.0%, Copper (Cu) 0.5%, Cobalt (Co) / Germanium (Ge) 0.1 to 0.3%

3.3. Important Notice 1

1. The service manual does not contain the following information, because of the impossibility of servicing at component level without concerned equipment/facilities.
 - a. Schematic diagram, Block Diagram and P.C.B. layout of MAIN P.C.B..
 - b. Parts list for individual parts for MAIN P.C.B..

When a part replacement is required for repairing MAIN P.C.B., replace as an assembled parts. (Main P.C.B.)
2. The following category is /are recycle module part. Please send it/them to Central Repair Center.
 - MAIN P.C.B. (VEP03J14BN: HDC-SD40P/PC/PU)
 - MAIN P.C.B. (VEP03J14BP: HDC-SD40EB/EC/EF/EG/EP, SD41EB)
 - MAIN P.C.B. (VEP03J14BQ: HDC-SD40EE/GA/GC/GK/GN/GW)
 - MAIN P.C.B. (VEP03J14AN: HDC-TM40P/PC/PU/GD, TM41P)
 - MAIN P.C.B. (VEP03J14AP: HDC-TM40EB)
 - MAIN P.C.B. (VEP03J14AQ: HDC-TM40GK)

3.4. How to Define the Model Suffix (NTSC or PAL model)







There are seven kinds of HDC-SD40/SD41/TM40/TM41.

- a) HDC-SD40P, TM40P, TM41P
- b) HDC-SD40PC, TM40PC
- c) HDC-SD40EB/EC/EF/EG/EP/GN, SD41EB, TM40EB
- d) HDC-SD40EE
- e) HDC-SD40GK, TM40GK
- f) HDC-TM40GD
- g) HDC-SD40GA/GC/GW/PU, TM40PU

What is the difference is that the "INITIAL SETTING" data which is stored in Flash ROM mounted on Main P.C.B..

3.4.1. Defining methods:

To define the model suffix to be serviced, refer to the rating label which is putted on the Unit.

<p>a) HDC-SD40P, TM40P, TM41P The nameplate for these models show the following Safety registration mark.</p> 
<p>b) HDC-SD40PC, TM40PC The nameplate for these models show the following Safety registration mark.</p> 
<p>c) HDC-SD40EB/EC/EF/EG/EP/GN, SD41EB, TM40EB The nameplate for these models show the following Safety registration mark.</p> 
<p>d) HDC-SD40EE The nameplate for this model shows the following Safety registration mark.</p> 
<p>e) HDC-SD40GK, TM40GK The nameplate for these models show the following Safety registration mark.</p> 
<p>f) HDC-TM40GD The nameplate for this model shows the following Safety registration mark.</p> 
<p>g) HDC-SD40GA/GC/GW/PU, TM40PU The nameplate for these models show the following Safety registration mark.</p>

NOTE:

After replacing the MAIN P.C.B., be sure to achieve adjustment.

The adjustment instruction is available at "software download" on the "Support Information from NDBG/VDBG-AVC" web-site in "TSN system", together with Maintenance software.

3.5. Formatting

HDC-SD40 / HDC-SD41 [FORMAT CARD]

Please be aware that if a medium is formatted, then all the data recorded on the medium will be erased and cannot be restored. Back up important data on a PC, DVD disc etc.

- When formatting is complete, press MENU button to exit the message screen.
- Perform a physical formatting of the SD card when the SD card is to be disposed/ transferred.

- Do not turn this unit off or remove the SD card, while formatting. Do not expose the unit to vibrations or shock.

Use this unit to format media.
Do not format an SD card using any other equipment such as a PC. The card may not be used on this unit.

HDC-TM40 / HDC-TM41 [FORMAT MEDIA]

Please be aware that if a medium is formatted, then all the data recorded on the medium will be erased and cannot be restored. Back up important data on a PC, DVD disc etc.

- 1 Select [FORMAT MEDIA] and press the ENTER button.
- 2 Select [Built-inMemory] or [SD CARD] using ▲/◀/▶, then press the ENTER button.

- When formatting is complete, press MENU button to exit the message screen.
- Perform a physical formatting of the SD card when the SD card is to be disposed/ transferred.
- Perform a physical formatting of the built-in memory when this unit is to be disposed/ transferred.

- Do not turn this unit off or remove the SD card, while formatting. Do not expose the unit to vibrations or shock.

Use this unit to format media.
Formatting built-in memory is only available with this unit.
Do not format an SD card using any other equipment such as a PC. The card may not be used on this unit.

When disposing of or giving away the SD card, note that:

- Formatting and deletion of this unit or computer only changes the file management information and does not completely delete the data in the SD card.
- It is recommended that the SD card is physically destroyed or the SD card is physically formatted using this unit when disposing of or giving away the SD card.

HDC-SD40 / HDC-SD41

To physically format the SD card, connect the unit via the AC adaptor, select [SETUP] → [FORMAT CARD] → [YES] from the menu, and then press and hold the delete/video light button on the screen below for about 3 seconds. When the SD card data deletion screen appears, select [YES], and then follow the on-screen instructions.

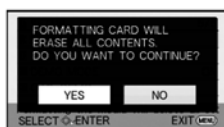

HDC-TM40 / HDC-TM41

To physically format the SD card, connect the unit via the AC adaptor, select [SETUP] → [FORMAT MEDIA] → [SD CARD] from the menu, and then press and hold the delete/video light button on the screen below for about 3 seconds. When the SD card data deletion screen appears, select [YES], and then follow the on-screen instructions.

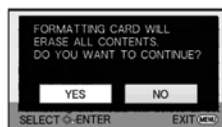

- The customer is responsible for the management of the data in the SD card.

HDC-TM40 / HDC-TM41

When disposing of or giving away this unit, note that:

- Formatting and deletion simply change the file management information and cannot be used to completely erase the data in built-in memory of this unit. The data can be recovered using commercially available software or the like.
- We recommend that you physically format the built-in memory before disposing of or giving away this unit.

To physically format the built-in memory, connect the unit via the AC adaptor, select [SETUP] → [FORMAT MEDIA] → [Built-inMemory] from the menu, and then press and hold the delete/video light button on the screen below for about 3 seconds. When the built-in memory data deletion screen appears, select [YES], and then follow the on-screen instructions.

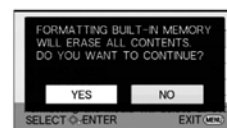

- Please look after the data in your built-in memory carefully. Panasonic will not be held responsible in the unlikely case that private data is divulged.

4 Specifications

High Definition Video Camera

Information for your safety

Power source:	DC 5.0 V (When using AC adaptor) DC 3.6 V (When using battery)
Power consumption:	Recording: 3.5 W Charging: 7.7 W

Signal system:

1080/60i, 540/30p (NTSC areas)
1080/50i, 540/25p (PAL areas)

Recording format:

[HA]/[HG]/[HX]: AVCHD format compliant
[iFrame]: MPEG-4 AVC file format compliant (.MP4)

Image sensor:

1/5.8" 1MOS image sensor
Total: 1500 K

Effective pixels:

Motion picture/Still picture: 1190 K (16:9)

Lens:

Auto Iris, 16.8× Optical Zoom, F1.8 to F2.6

Focal length:

2.9 mm to 48.7 mm

Macro (Full range AF)

35 mm equivalent:

Motion picture/Still picture: 42.9 mm to 721 mm (16:9)

Minimum focus distance:

Normal: Approx. 4 cm (1.6") (Wide)/Approx. 1.2 m (3.9 feet) (Tele)
Tele macro: Approx. 50 cm (20") (Tele)

Zoom:

[HDC-SD40]/[HDC-TM40]
16.8× Optical Zoom, 50×/1200× Digital Zoom

[HDC-SD41]/[HDC-TM41]
16.8× Optical Zoom, 50×/1500× Digital Zoom

Image stabilizer function:

Optical (Active mode)

Monitor:

2.7" wide LCD monitor (Approx. 230 K dots)

Microphone:

Stereo

Speaker:

1 round speaker, dynamic type

White balance adjustment:

Auto tracking white balance system

Standard illumination:

1,400 lx

Minimum required illumination:

Approx. 7 lx (1/30 with Low light mode in the Scene mode) (NTSC areas)

Approx. 1 lx with the Color Night Rec function (NTSC areas)

Approx. 7 lx (1/25 with low light mode in the scene mode) (PAL areas)

Approx. 1 lx with the colour night view function (PAL areas)

AV multi connector video output level:

Component video output level:

Y: 1.0 Vp-p, 75 Ω

Pb: 0.7 Vp-p, 75 Ω

Pr: 0.7 Vp-p, 75 Ω

AV video output level:

1.0 Vp-p, 75 Ω, NTSC system (NTSC areas)

1.0 Vp-p, 75 Ω, PAL system (PAL areas)

HDMI mini connector video output level:

HDMI™ 1080i/480p (NTSC areas)

HDMI™ 1080i/576p (PAL areas)

AV multi connector audio output level (Line):

316 mV, 600 Ω, 2 ch

HDMI mini connector audio output level:

Linear PCM

USB:

Reader/writer function

SD card: Read only (No copyright protection support) (EB/EF/EG/EP areas)

SD card: Read/Write (No copyright protection support) (Other areas)

[HDC-TM40]/[HDC-TM41]

Built-in memory: Read only

Hi-Speed USB (USB 2.0), USB terminal Type Mini B

Battery charging function (Charges from USB terminal when the main unit is off)

Dimensions:

51.5 mm (W)×57.5 mm (H)×108.5 mm (D)

[2.03" (W)×2.26" (H)×4.27" (D)] (excluding projecting parts)

Mass (Weight):

[HDC-SD41]/[HDC-TM41]

Approx. 169 g (Approx. 0.37 lbs.)

[without battery (supplied) and an SD card (optional)]

[HDC-TM40]/[HDC-TM41]

Approx. 169 g (Approx. 0.37 lbs.)

[without battery (supplied)]

Mass (Weight) in operation:

[HDC-SD41]/[HDC-TM41]

Approx. 213 g (Approx. 0.47 lbs.)

[with battery (supplied) and an SD card (optional)]

[HDC-TM40]/[HDC-TM41]

Approx. 211 g (Approx. 0.47 lbs.)

[with battery (supplied)]

Operating temperature:

0 °C to 40 °C (32 °F to 104 °F)

Operating humidity:

10%RH to 80%RH

Battery operation time:

See "Charging and recording time"

■ Motion pictures

Recording media:

SD Memory Card (FAT12 and FAT16 system compliant)

SDHC Memory Card (FAT32 system compliant)

SDXC Memory Card (exFAT system compliant)

Refer to "Recording to a card" for details on SD cards usable in this unit.

[HDC-TM40]/[HDC-TM41]

Built-in memory: 16 GB

Compression:

MPEG-4 AVC/H.264

Recording mode and transfer rate:

[HA]: Approx. 17 Mbps (VBR)

[HG]: Approx. 13 Mbps (VBR)

[HX]: Approx. 9 Mbps (VBR)

[iFrame]: Approx. 28 Mbps (VBR)

Refer to "Recording modes/approximate recordable time" for the recordable time.

Picture size:

[HA]/[HG]/[HX]: 1920×1080/60i (NTSC areas)

[iFrame]: 960×540/30p (NTSC areas)

[HA]/[HG]/[HX]: 1920×1080/50i (PAL areas)

[iFrame]: 960×540/25p (PAL areas)

Audio compression:

AVCHD: Dolby Digital (2 ch)

iFrame: AAC (2 ch)

■ Still pictures

Recording media:

SD Memory Card (FAT12 and FAT16 system compliant)

SDHC Memory Card (FAT32 system compliant)

SDXC Memory Card (exFAT system compliant)

Refer to "Recording to a card" for details on SD cards usable in this unit.

[HDC-TM40]/[HDC-TM41]

Built-in memory: 16 GB

Compression:

JPEG (Design rule for Camera File system, based on Exif 2.2 standard)

Picture size:

Picture aspect [16:9]: 1920×1080

Refer to "Approximate number of recordable pictures" for the number of recordable pictures.

AC adaptor

Information for your safety

Power source:	AC 110 V to 240 V, 50/60 Hz
Power consumption:	12 W
DC output:	DC 5.0 V, 1.6 A

Dimensions:

46 mm (W)×25 mm (H)×75.5 mm (D) [1.8" (W)×1.0" (H)×3.0" (D)]

Mass (Weight):

Approx. 115 g (Approx. 0.25 lbs.)

Specifications may change without prior notice.

Charging and recording time

Charging/Recording time

- Temperature: 25 °C (77 °F)/humidity: 60%RH (When using AC adaptor)

HDC-SD40 (NTSC areas)				
Battery model number [Voltage/Capacity (minimum)]	Charging time	Recording mode	Maximum continuous recordable time	Actual recordable time
Supplied battery/ VW-VBK180 (optional) [3.6 V/1790 mAh]	2 h 25 min	[HA], [HG], [HX]	2 h 15 min	1 h 10 min
		[iFrame]	2 h 40 min	1 h 25 min
VW-VBK360 (optional) [3.6 V/3580 mAh]	4 h 20 min	[HA], [HG]	4 h 30 min	2 h 20 min
		[HX]	4 h 35 min	2 h 20 min
		[iFrame]	5 h 20 min	2 h 45 min

HDC-TM40/HDC-TM41 (NTSC areas)				
Battery model number [Voltage/Capacity (minimum)]	Charging time	Recording mode	Maximum continuous recordable time	Actual recordable time
Supplied battery/ VW-VBK180 (optional) [3.6 V/1790 mAh]	2 h 25 min	[HA], [HG], [HX]	2 h 15 min	1 h 10 min
		[iFrame]	2 h 40 min	1 h 25 min
VW-VBK360 (optional) [3.6 V/3580 mAh]	4 h 20 min	[HA], [HG]	4 h 30 min	2 h 20 min
		[HX]	4 h 35 min	2 h 20 min
		[iFrame]	5 h 20 min	2 h 45 min

HDC-SD40/HDC-SD41 (PAL areas)				
Battery model number [Voltage/Capacity (minimum)]	Charging time	Recording mode	Maximum continuously recordable time	Actual recordable time
Supplied battery/ VW-VBK180 (optional) [3.6 V/1790 mAh]	2 h 25 min	[HA], [HG], [HX]	2 h 15 min	1 h 10 min
		[iFrame]	2 h 40 min	1 h 25 min
VW-VBK360 (optional) [3.6 V/3580 mAh]	4 h 20 min	[HA], [HG]	4 h 30 min	2 h 20 min
		[HX]	4 h 35 min	2 h 20 min
		[iFrame]	5 h 20 min	2 h 45 min

HDC-TM40 (PAL areas)				
Battery model number [Voltage/Capacity (minimum)]	Charging time	Recording mode	Maximum continuously recordable time	Actual recordable time
Supplied battery/ VW-VBK180 (optional) [3.6 V/1790 mAh]	2 h 25 min	[HA], [HG], [HX]	2 h 15 min	1 h 10 min
		[iFrame]	2 h 40 min	1 h 25 min
VW-VBK360 (optional) [3.6 V/3580 mAh]	4 h 20 min	[HA], [HG]	4 h 30 min	2 h 20 min
		[HX]	4 h 35 min	2 h 20 min
		[iFrame]	5 h 20 min	2 h 45 min

- These times are approximations.
- The indicated charging time is for when the battery has been discharged completely. Charging time and recordable time vary depending on the usage conditions such as high/low temperature.
- The actual recordable time refers to the recordable time when repeatedly starting/stopping recording, turning the unit on/off, moving the zoom lever etc.
- The batteries heat up after use or charging. This is not a malfunction.

Recording to a card

The unit can record still pictures or motion pictures to an SD card or built-in memory. To record to an SD card, read the following.

This unit (an SDXC compatible device) is compatible with SD Memory Cards, SDHC Memory Cards and SDXC Memory Cards. When using an SDHC memory card/SDXC memory card with other equipment, check the equipment is compatible with these memory cards.

Cards that you can use with this unit

Use SD cards conforming to Class 4 or higher of the SD Speed Class Rating* for motion picture recording.

Card type	Capacity	Motion picture recording	Still picture recording
SD Memory Card	8 MB/16 MB/ 32 MB	Cannot be used.	Cannot be guaranteed in operation.
	64 MB/128 MB/ 256 MB	Cannot be guaranteed in operation.	
	512 MB/1 GB/ 2 GB		
SDHC Memory Card	4 GB/6 GB/8 GB/ 12 GB/16 GB/ 24 GB/32 GB	Can be used.	Can be used.
SDXC Memory Card	48 GB/64 GB		

* SD Speed Class Rating is the speed standard regarding continuous writing. e.g.:
Check via the label on the card, etc.



Recording modes/approximate recordable time

- SD cards are only mentioned with their main memory size. The stated times are the approximate recordable times for continuous recording.

Recording mode		[HA]	[HG]	[HX]
Picture size		1920×1080	1920×1080	1920×1080
SD card	4 GB	30 min	40 min	1 h
	16 GB	2 h	2 h 40 min	4 h 10 min
	64 GB	8 h 30 min	11 h	16 h 50 min
HDC-TM40 HDC-TM41 Built-in memory	16 GB	2 h	2 h 40 min	4 h 10 min

- A Favors image quality
- B Favors recording time

Recording mode		[iFrame]
Picture size		960×540
SD card	4 GB	19 min
	16 GB	1 h 20 min
	64 GB	5 h 20 min
HDC-TM40 HDC-TM41 Built-in memory	16 GB	1 h 20 min

- If recording for long periods, prepare batteries for 3 or 4 times the period you wish to record for.
- The default setting is [HG] Mode.
- Maximum continuously recordable time for one scene: 6 hours
- The recording is paused once when the recording time for one scene exceeds 6 hours, and the recording will automatically resume after a few seconds.
- If a recording with a lot of action is recorded, the recording time is reduced.
- The recordable time may be reduced if recording of short scene is repeated.
- Use time in the row of 4 GB in above table as a guideline for the time that can be copied onto one DVD disc (4.7 GB).

Approximate number of recordable pictures

- SD cards are only mentioned with their main memory size. The stated number is the approximate number of recordable pictures.

(When [QUALITY] is set to)

Picture size		1920×1080
Aspect ratio		16:9
SD card	4 GB	3600
	16 GB	14000
	64 GB	59000
HDC-TM40 HDC-TM41 Built-in memory	16 GB	14000

- When [QUALITY] is set to , the numbers of recordable pictures are larger than the numbers shown in the table above.
- The number of recordable pictures depends on whether and are used together and on the subject being recorded.
- The memory capacity indicated on the label of an SD card is the total of the capacity for copyright protection and management and the capacity which can be used on the unit, a PC etc.

5 Location of Controls and Components

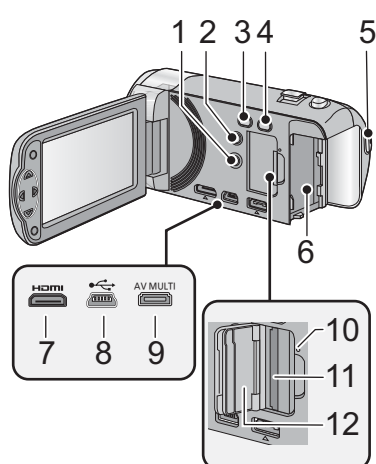

- 1 Power button [⏻/⏺]
 - 2 Delete/Video light button [🗑️/LIGHT]
 - 3 Intelligent auto/Manual button [iA/MANUAL]
 - 4 Optical image stabilizer button [🌀O.I.S.]
 - 5 Recording start/stop button
 - 6 Battery holder
 - 7 HDMI mini connector [HDMI]
 - 8 USB terminal [🔌]
 - 9 AV multi connector
- Use the AV multi cable (only the supplied cable).
- 10 Access lamp [ACCESS]
 - 11 Card slot
 - 12 SD card cover

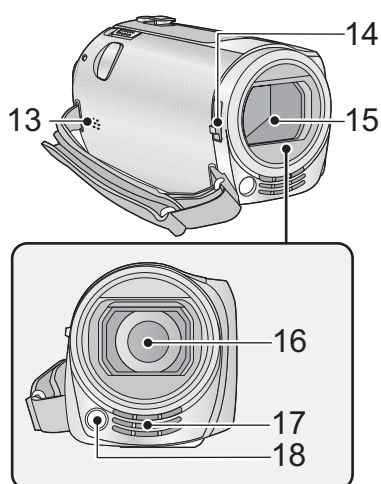

- 13 Speaker
 - 14 Lens cover opening/closing switch
- When not using the unit, close the lens cover to protect the lens.
- Slide the opening/closing switch to open/close the cover.

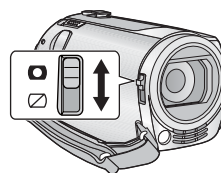

- 15 Lens cover
- 16 Lens
- 17 Internal stereo microphones
- 18 Video light

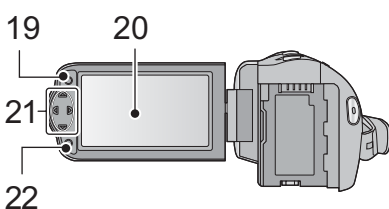

- 19 Menu button [MENU]
- 20 LCD monitor

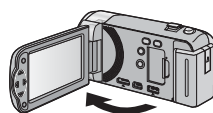

- It can open up to 90°.

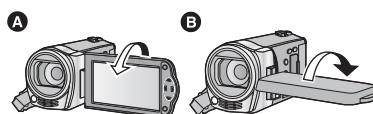

- It can rotate up to 180° **A** towards the lens or 90° **B** towards the opposite direction.

Due to limitations in LCD production technology, there may be some tiny bright or dark spots on the LCD monitor screen. However, this is not a malfunction and does not affect the recorded picture.

- 21 cursor button
- Use the cursor button to select the recording functions and playback operations, and to operate the menu screen.
- 22 Enter button [ENTER]

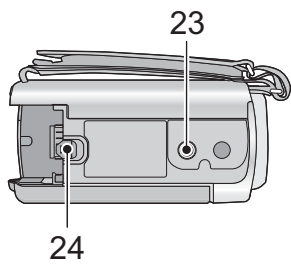

23 Tripod receptacle

- If you attach a tripod which has a 5.5 mm (0.22 ") screw or larger, it may damage this unit.

24 Battery release lever [BATT]

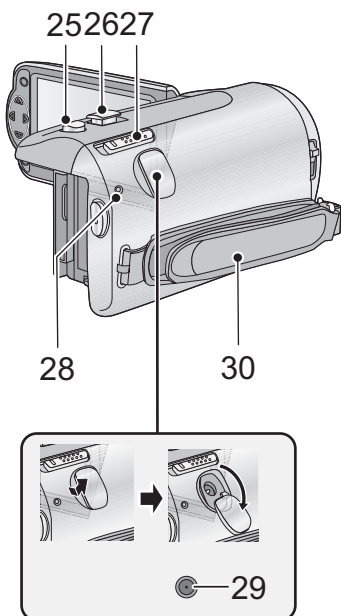

25 Photoshot button []

26 Zoom lever [W/T] (In Recording Mode)

Thumbnail display switch [ / ] / Volume lever [-VOL+] (In Playback Mode)

27 Mode switch

28 Status indicator

29 DC input terminal [DC IN]

- Do not use any other AC adaptors except the supplied one.

30 Grip belt

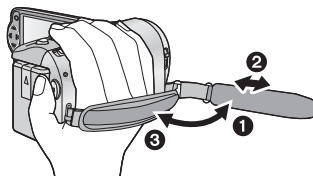

Adjust the length of the grip belt so that it fits your hand.





- 1 Flip the belt.
- 2 Adjust the length.
- 3 Replace the belt.

Selecting a mode

Change the mode to recording or playback.

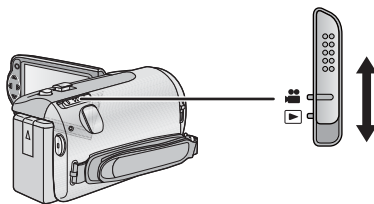
Operate the mode switch to change the mode to  or .



	Recording Mode
	Playback Mode

6 Service Fixture & Tools

6.1. When Replacing the Main P.C.B.

After replacing the MAIN P.C.B., be sure to achieve adjustment.

The adjustment instruction is available at “software download” on the “Support Information from NWBG/VDBG-AVC” web-site in “TSN system”, together with Maintenance software.

6.2. Service Position

This Service Position is used for checking and replacing parts. Use the following Extension cables for servicing.

Table S1 Extension Cable List

No.	Parts No.	Connection	Form
1	RFKZ0487	FP6004(MAIN) - MONITOR FPC	35PIN 0.3 FFC
2	RFKZ0343	PP6007(MAIN) - PS6401(SD HOLDER)	30PIN 0.5 B to B
3	VFK1480	FP6003(MAIN) - ECM FPC	6PIN 0.5 FFC
4	VFK1895	PP6003(MAIN) - POWER FPC	40PIN 0.5 B to B

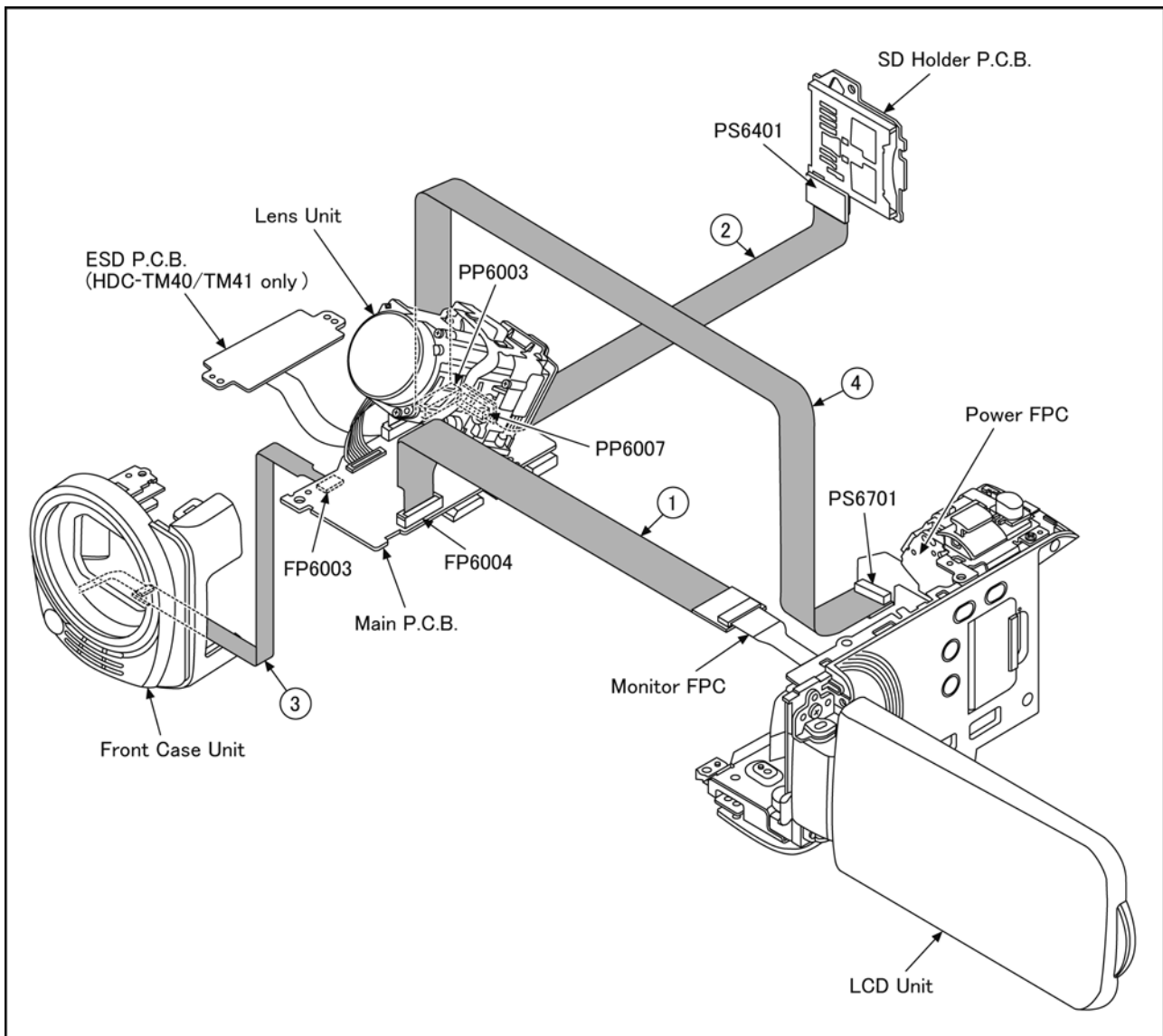

7 Disassembly and Assembly Instructions

7.1. Disassembly Flow Chart

This is a disassembling chart.

When assembling, perform this chart conversely.

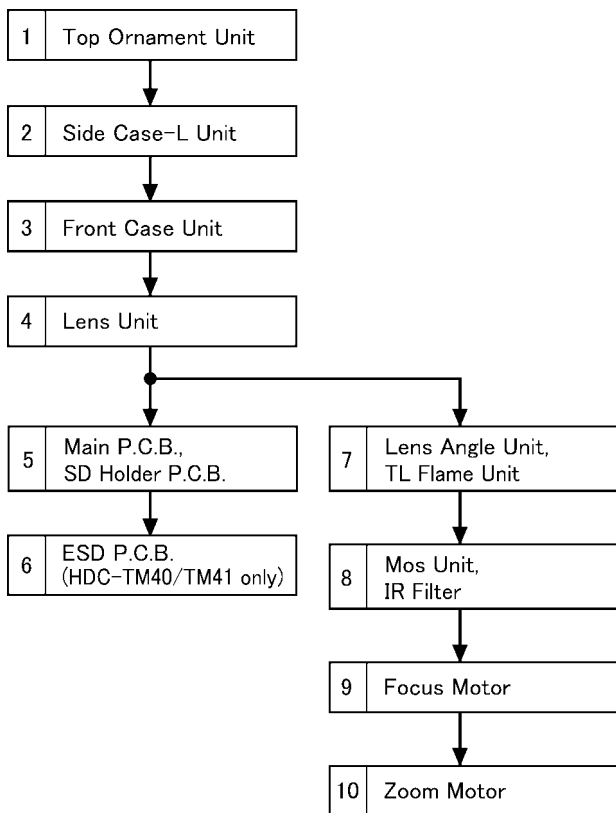

7.2. PCB Location

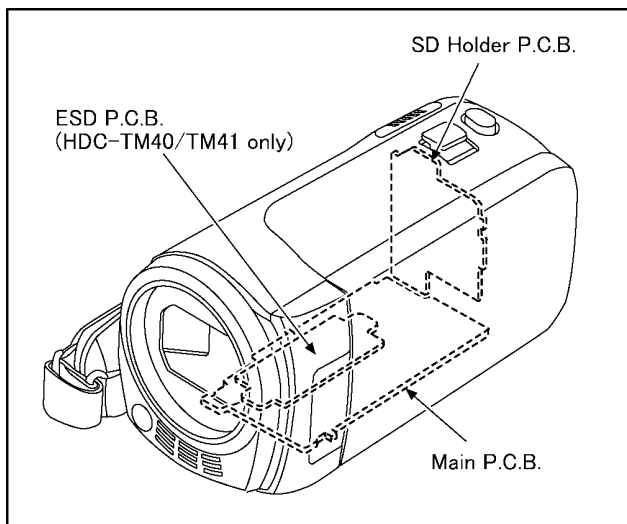

7.3. Disassembly Procedure

No.	Item	Fig	Removal
1	Top Ornament Unit	(Fig. D1)	1 Screw (A)
		(Fig. D2)	2 Locking tabs 2 Hanging parts Top Ornament Unit
2	Side Case-L- Unit	(Fig. D3)	2 Screws (B) 1 Screw (C)
		(Fig. D4)	1 Screw (D) 2 Screws (E) 3 Locking tabs P6401 (Connector) Side Case-L Unit
3	Front Case Unit	(Fig. D5)	FP6003 (Flex) 1 Screw (F) 1 Screw (G) 1 Screw (H) 1 Locking tab Front Case Unit
4	Lens Unit	(Fig. D6)	2 Screws (I) 1 Screw (J) PP6003 (Connector) 3 Locking tabs PP6006 (Connector) FP6002 (Flex) Lens Unit
5	Main P.C.B. SD Holder P.C.B.	(Fig. D7)	2 Screws (K) FP6004 (Flex) 1 Rib FP3201 (Flex)
		(Fig. D8)	1 Hanging part Radiation Plate Main P.C.B. SD Holder P.C.B.
6	ESD P.C.B. (HDC-TM40/TM41 only)	(Fig. D9)	2 Screws (L) ESD P.C.B.
7	Lens Angle Unit TL Frame Unit	(Fig. D10)	1 Locking tab 3 Convexes Lens Angle Unit TL Frame Unit
8	MOS Unit IR Filter	(Fig. D11)	1 Screw (M) 1 Screw (N) MOS Cushion MOS Unit IR Filter
9	Focus Motor	(Fig. D12)	3 Screws (O) 4 Solders 2 Convexes Focus Motor
10	Zoom Motor	(Fig. D13)	3 Screws (P) 4 Solders 2 Convexes Zoom Motor

NOTE:

When servicing and reassembling, remove the card and battery pack from the unit.

- Card
- Battery Pack

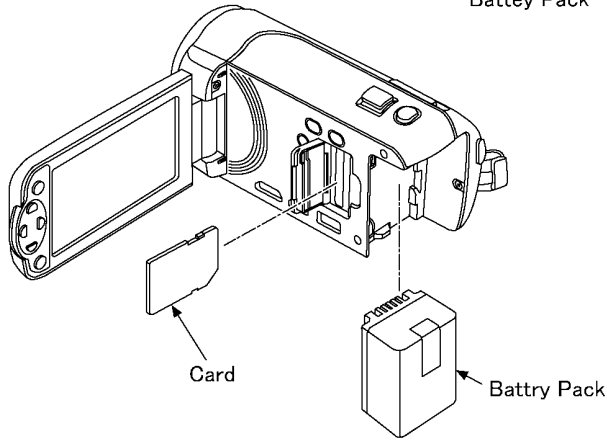

7.3.1. Removal of the Top Ornament Unit

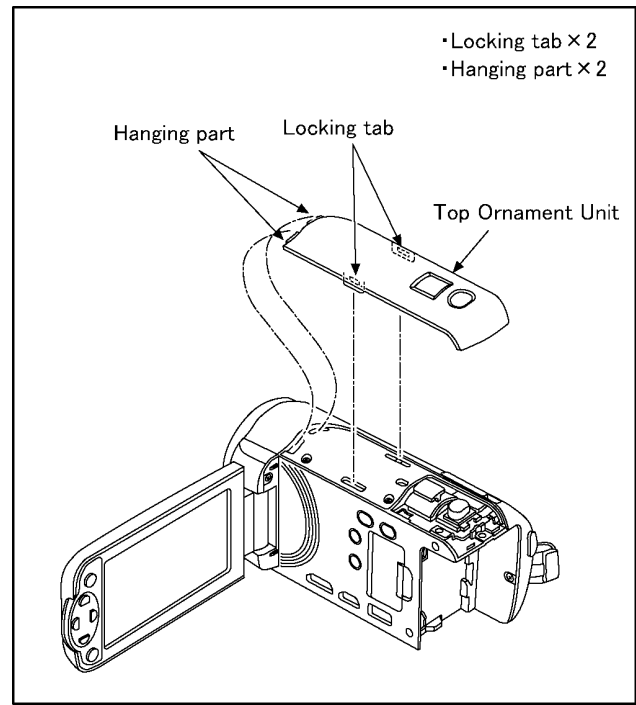

(Fig. D2)

7.3.2. Removal of the Side Case-L Unit

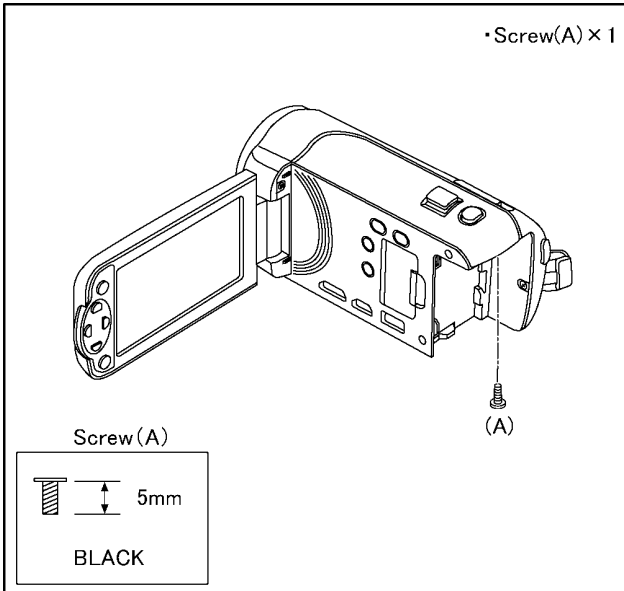

(Fig. D1)

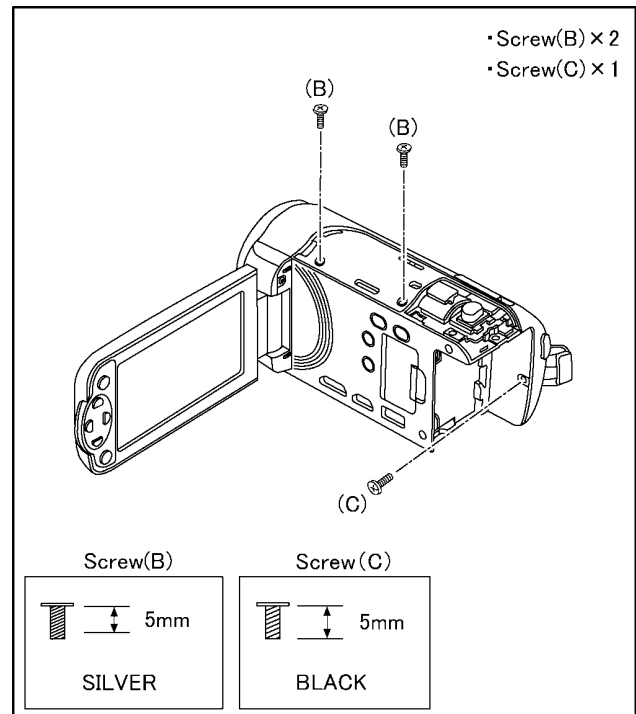

(Fig. D3)

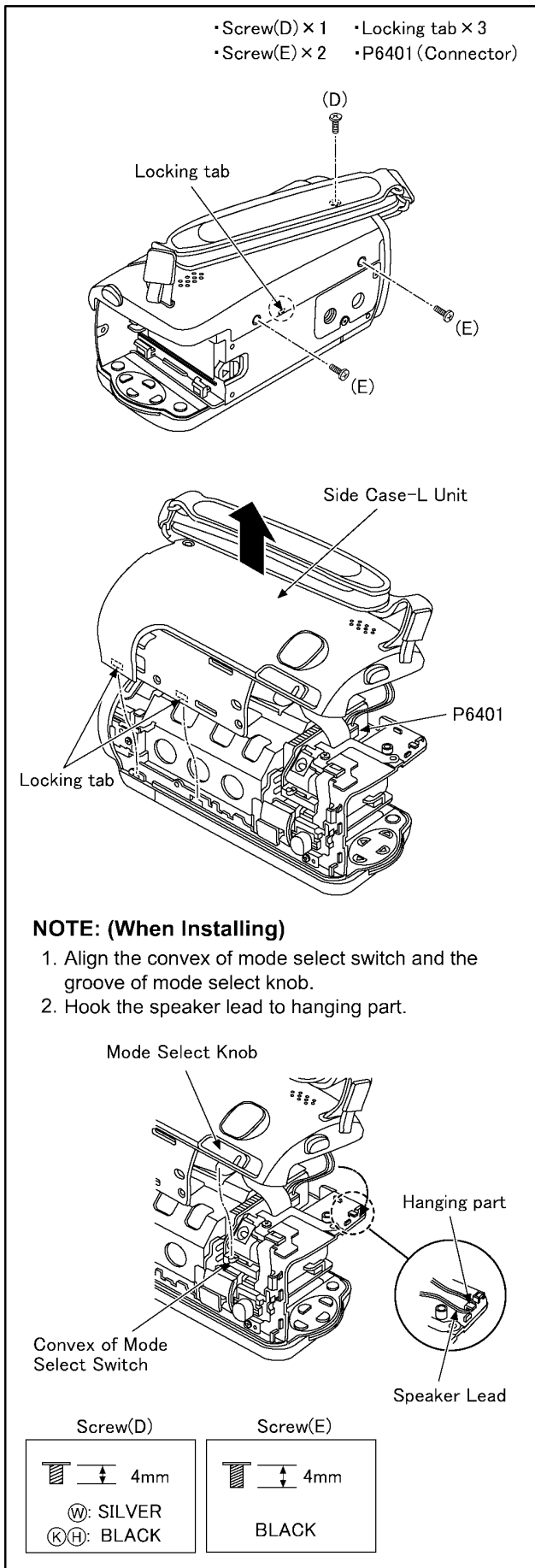

(Fig. D4)

7.3.3. Removal of the Front Case Unit

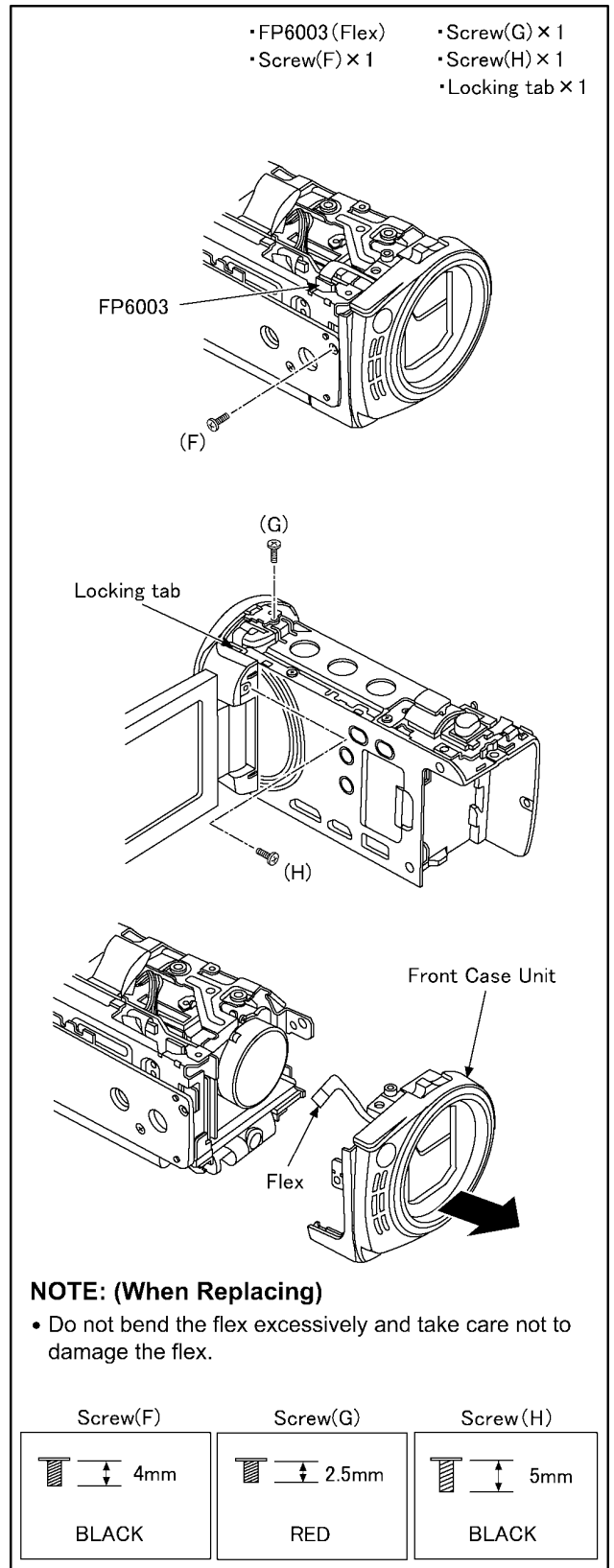

(Fig. D5)

7.3.4. Removal of the Lens Unit

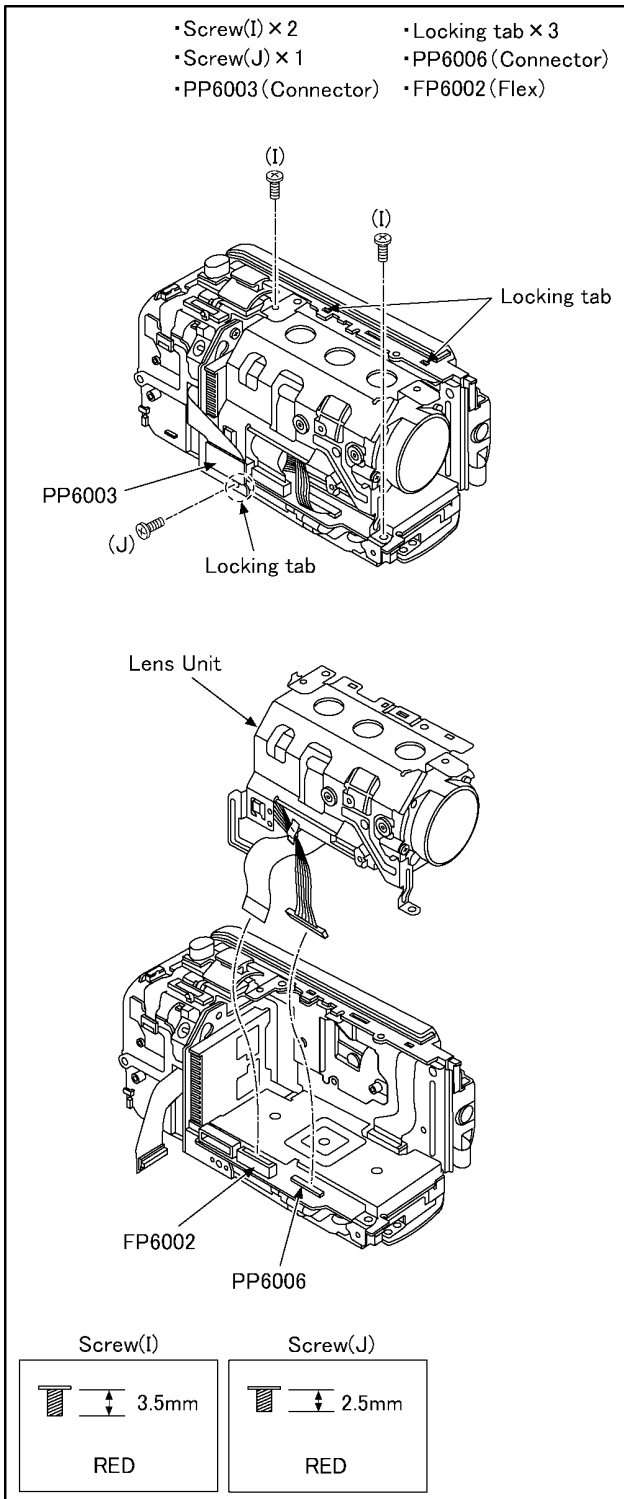

(Fig. D6)

7.3.5. Removal of the Main P.C.B. and SD Holder P.C.B.

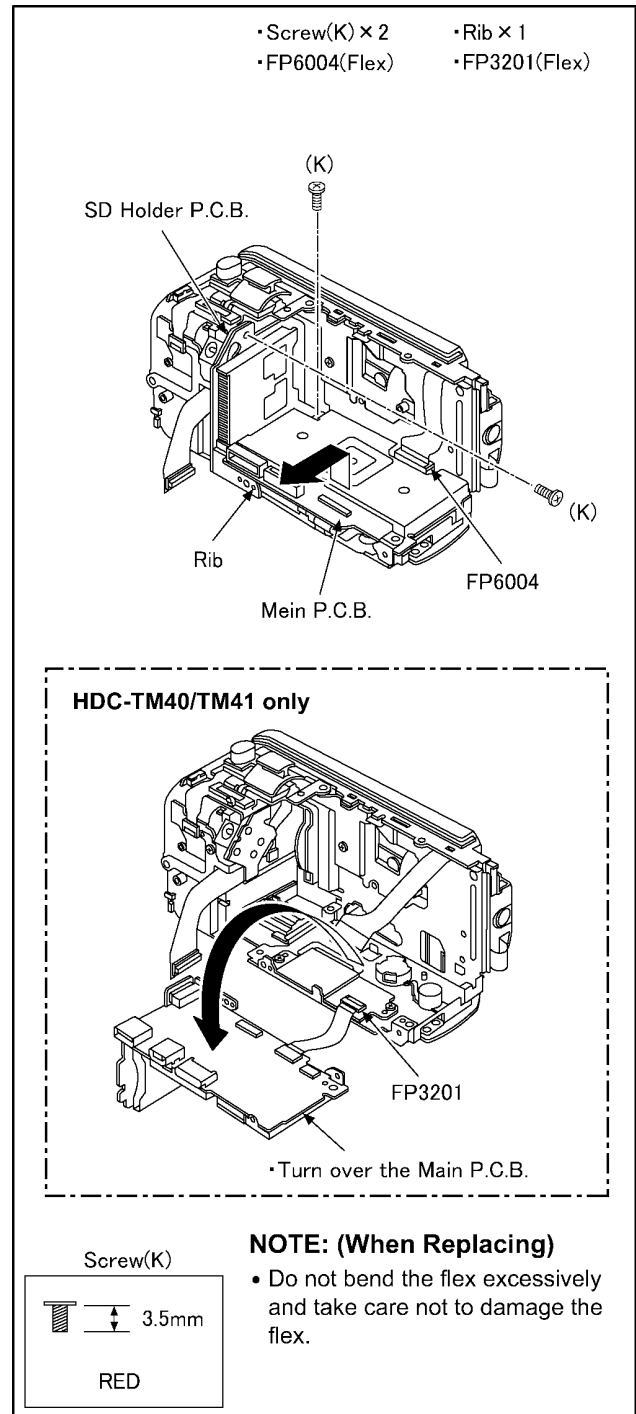

(Fig. D7)

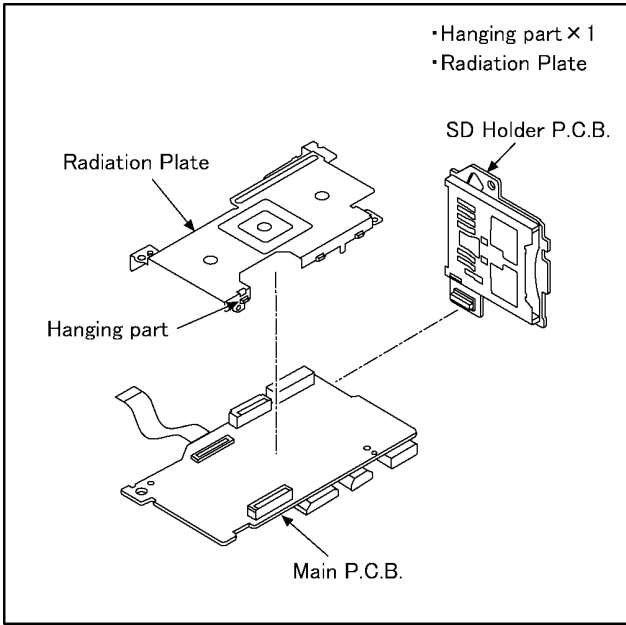

(Fig. D8)

7.3.6. Removal of the ESD P.C.B. (HDC-TM40/TM41 only)

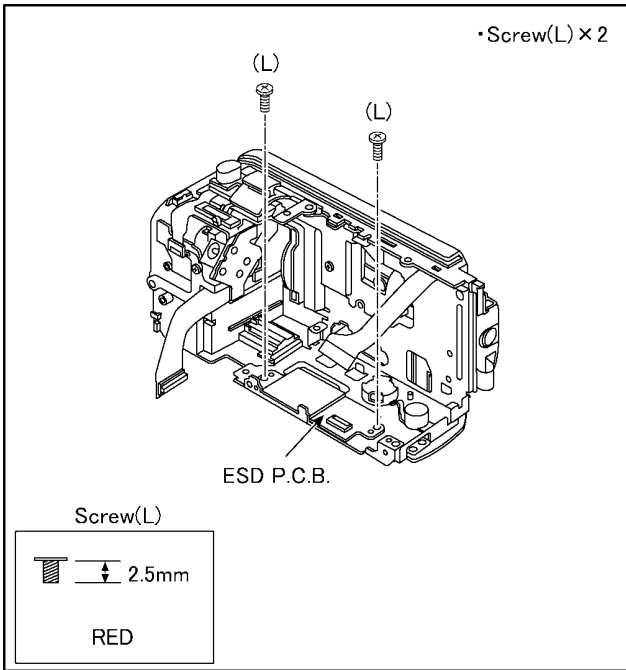

(Fig. D9)

7.3.7. Removal of the Lens Angle Unit and TL Frame Unit

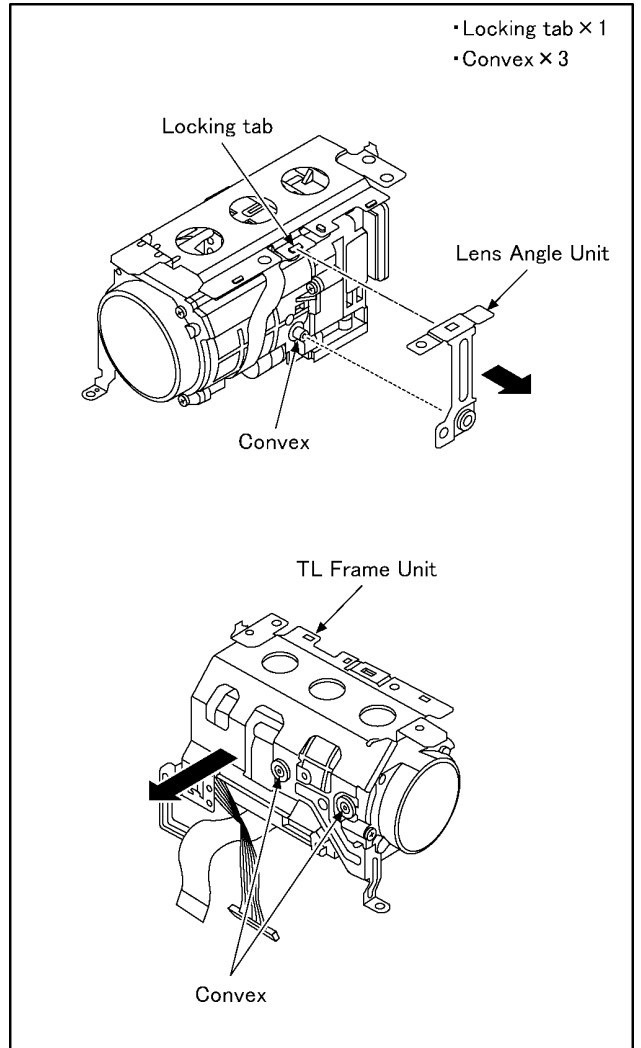

(Fig. D10)

7.3.8. Removal of the MOS Unit and IR Filter

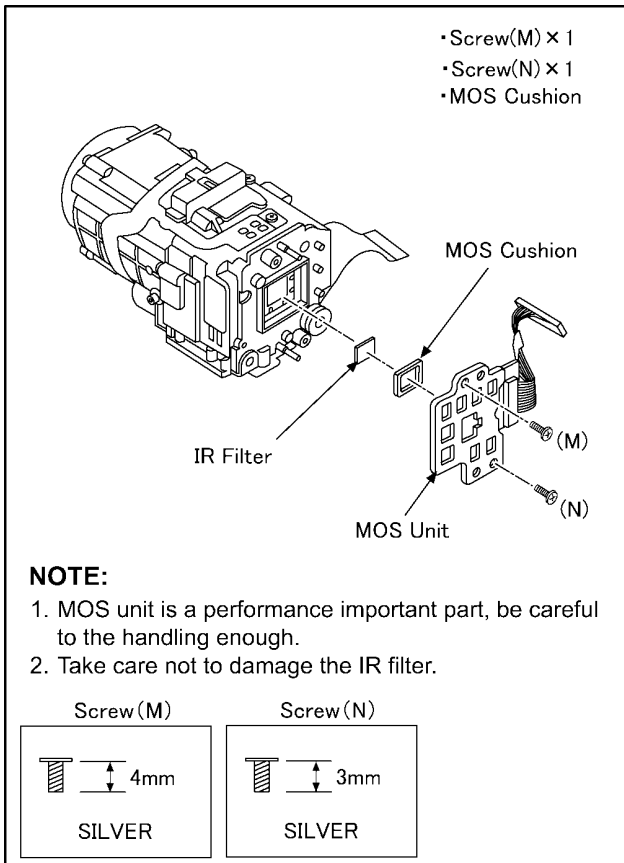

(Fig. D11)

7.3.9. Removal of the Focus Motor

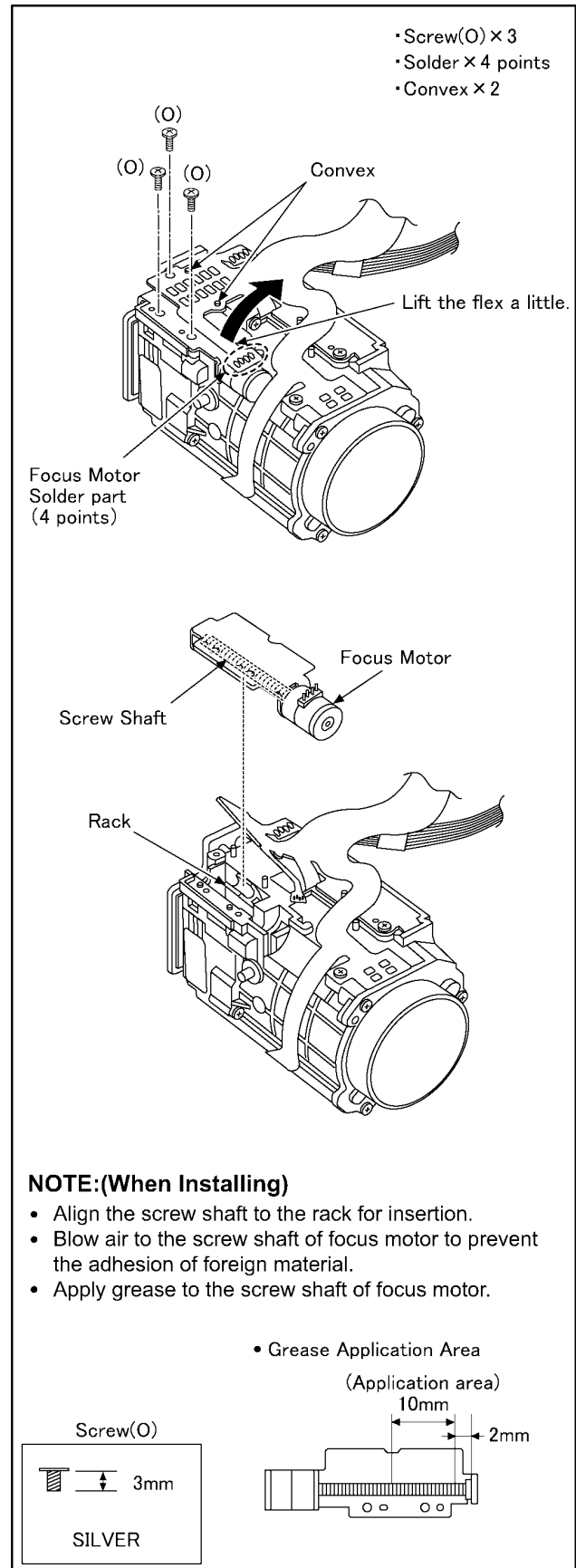

(Fig. D12)

7.3.10. Removal of the Zoom Motor

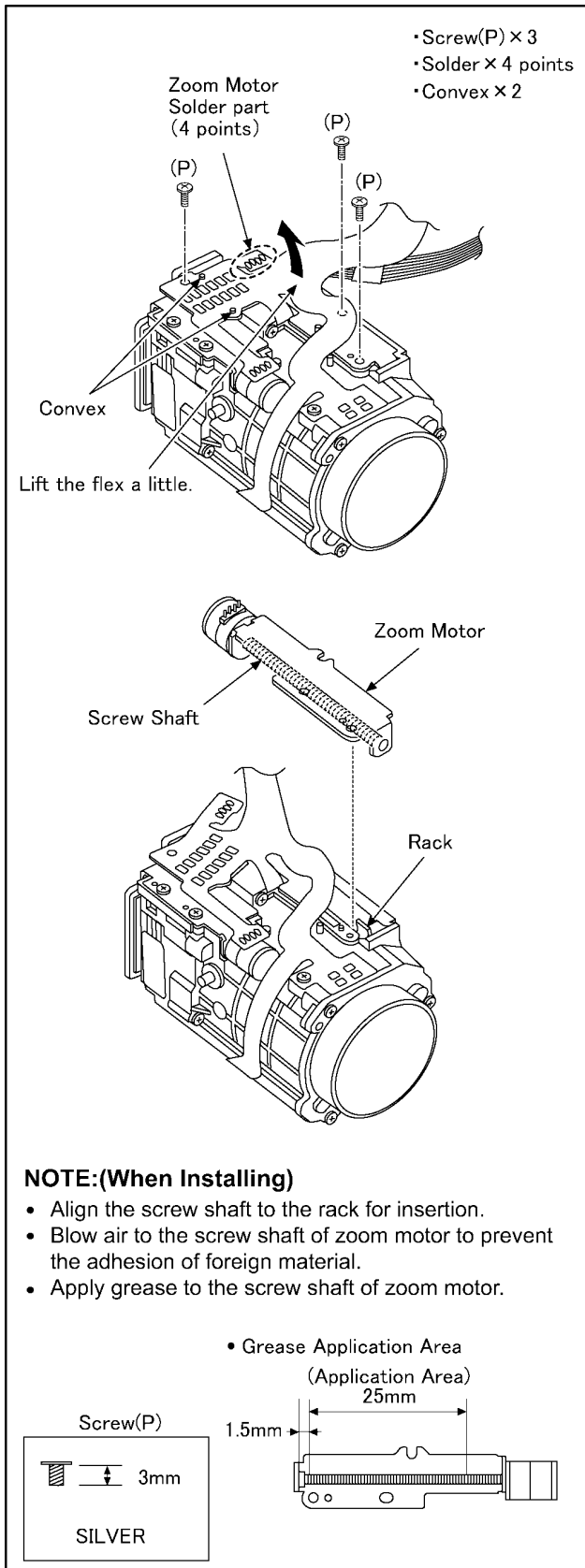

(Fig. D13)

8 Measurements and Adjustments

8.1. Electric Adjustment

- Adjustment method is different from a conventional High definition video camera.
- An exclusive jig and PC (including software for adjustment "Tatsujin") are necessary for electric adjustment.
- A USB driver for service is necessary to communication with PC.
- Connection method of the main unit and an exclusive adjustment jig as follows

8.1.1. Adjustment Procedure

- Connect the main unit to PC with USB.
The adjustment instruction is available at "Software download" on the "Support Information from NWBG/VDBG-AVC" web-site in "TSN System".

Figure of connection

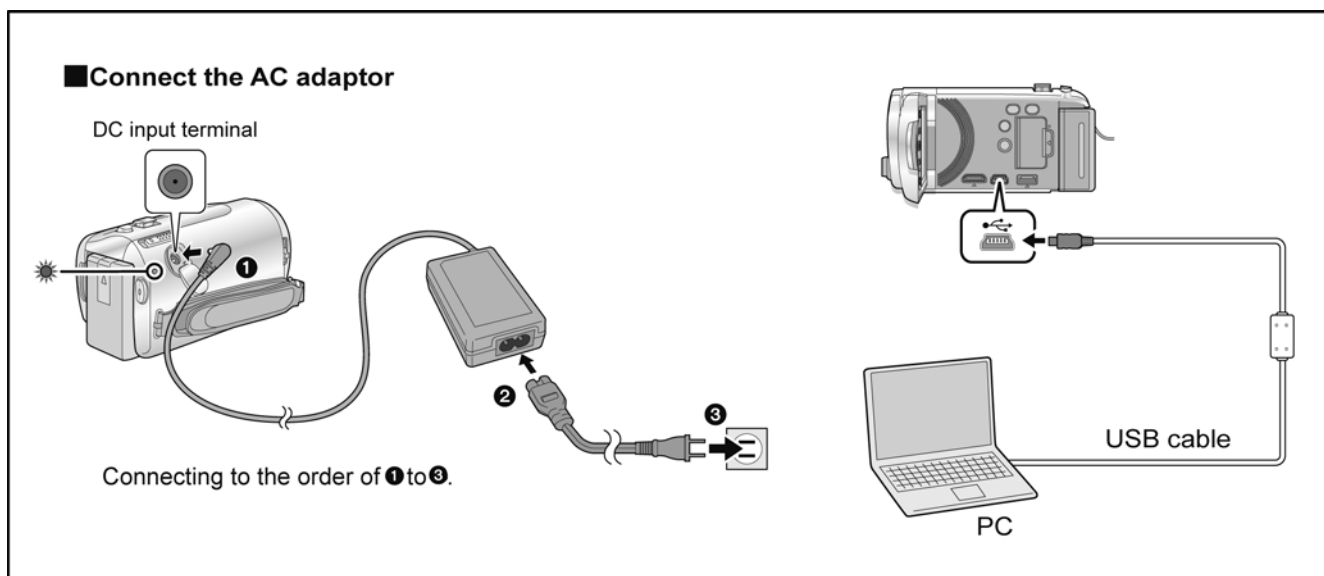
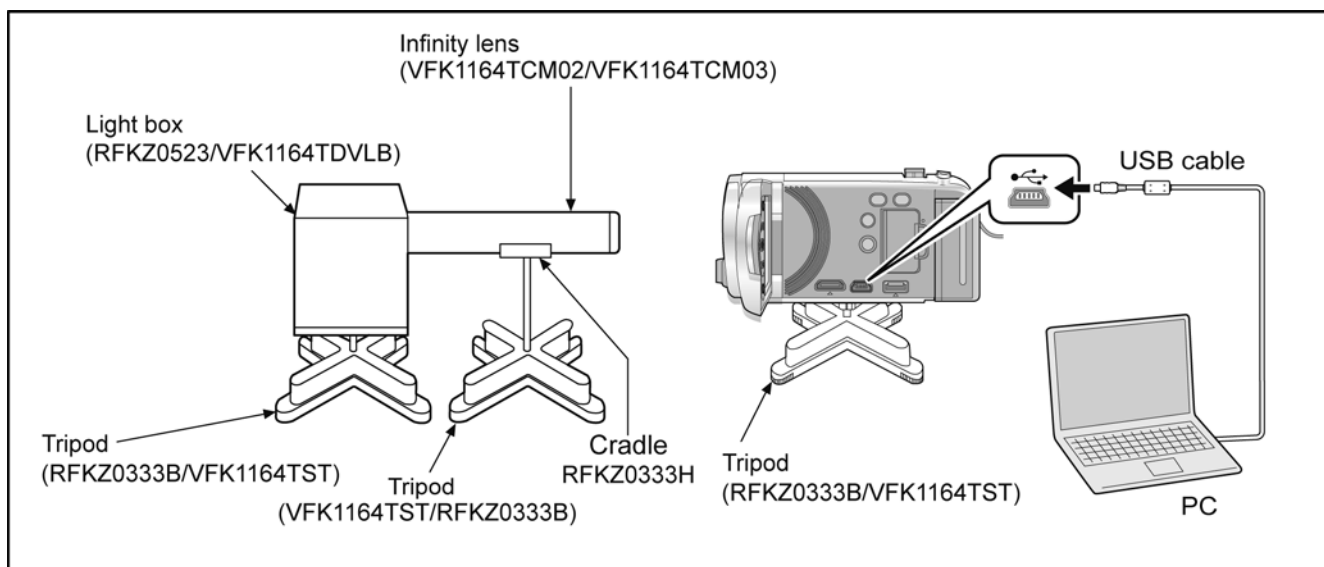

Figure of image when adjustment



Part Number of jig

- Only a necessary jig mentions it in setup of electric adjustment.

No.	Part Name	Part Number	Remarks
1	PC	-----	
2	AC Adaptor	-----	
3	USB Cable	-----	
4	Adjustment Software (Tatsujin)	-----	

Adjustment Items

- Adjustment item as follows.

The adjustment instruction is available at "Software download" on the "Support Information from NWBG/VDBG-AVC" web-site in "TSN System".

	Replacement part		Main P.C.B.	IC2002(EEPROM)	Lens Unit	MOS Unit	IC6401
	Adjustment item						
Camera Part	● Hall amplifire/PWM bias/ OIS Hall amplifire adjustment (automatic)		<input type="radio"/>	<input type="radio"/>	<input type="radio"/>		<input type="radio"/>
	● OIS Sensor Offset adjustment (automatic)		<input type="radio"/>	<input type="radio"/>	<input type="radio"/>		<input type="radio"/>
	● Zoom tracking adjustment (automatic)		<input type="radio"/>	<input type="radio"/>	<input type="radio"/>	<input type="radio"/>	
	● Address wound revision (automatic)		<input type="radio"/>	<input type="radio"/>		<input type="radio"/>	
	● White balance adjustment (manual)		<input type="radio"/>	<input type="radio"/>		<input type="radio"/>	

9 Factory Setting

9.1. How To Turn On The Factory Settings?

(CAUTION)

Performing the factory settings, the built-in memory is initialized and all of recorded data are deleted. (SD memory card is not initialized by the factory settings.)

1. Set the mode switch "Recording" mode.
2. Turn the power on, and then while keep pressing the "Zoom lever" to W side, "Intelligent auto/Manual" button and "Menu" button for more than 3 seconds until the top screen of the Service Mode Menu being displayed.

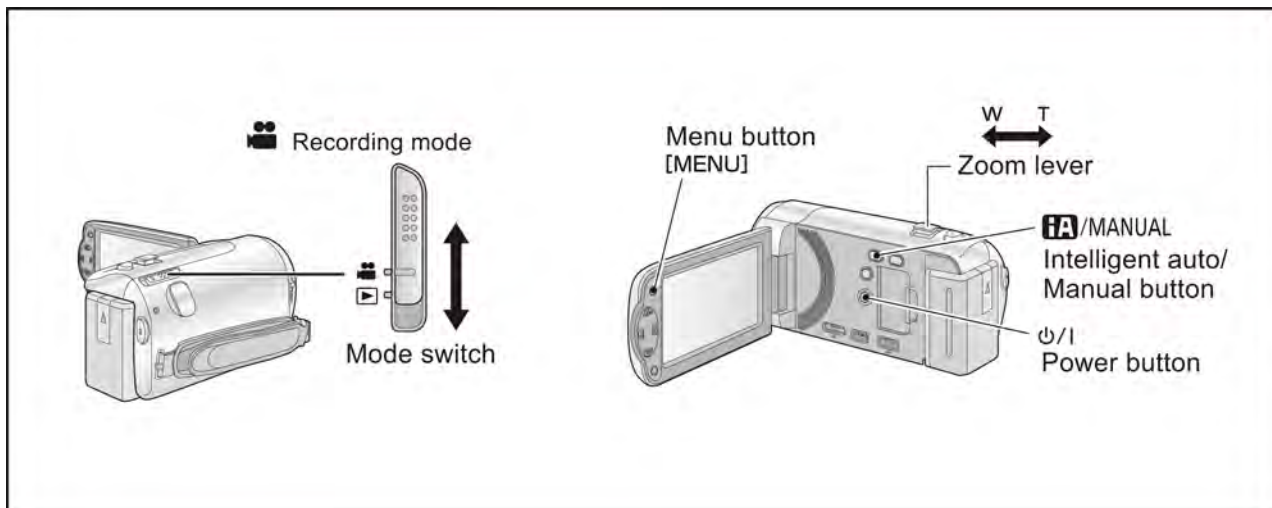

3. Under the condition of the Item No. "1" is yellow high lighted , then press "ENTER" button.
4. By pressing the "[UP] or [DOWN] of cursor" button and display a highlight in a "YES" item, then press the "ENTER" button.
5. After few seconds "END" is displayed on LCD monitor. Cutting of battery connection or AC power supply connection as a completion of the "FACTORY SETTINGS".

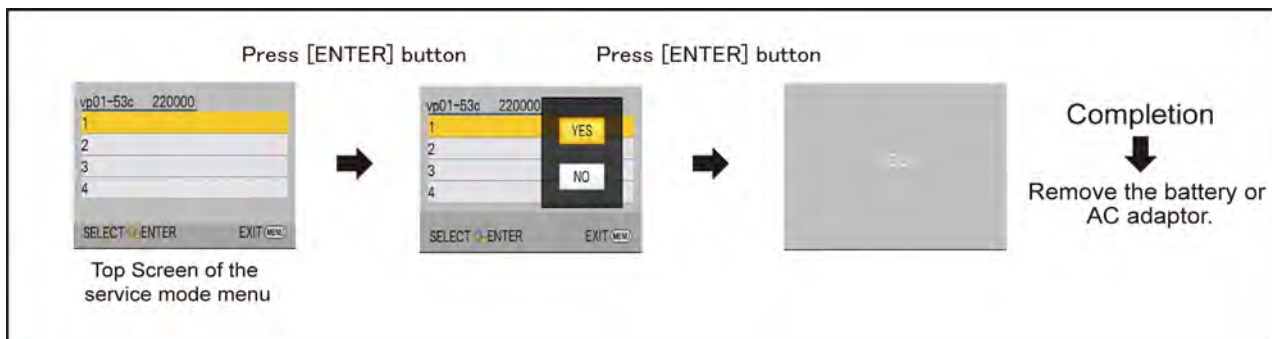

NOTE:

Do not using service mode except above table of Service mode menu.
 End method of the top screen of the service mode menu.
 Push the [MENU] button to end the service mode, and then POWER OFF.

9.2. What Is The Factory Settings?

The factory settings clean up and/or refresh the following settings.

1. Physical formatting of the built-in memory. (All user recorded data are deleted)
2. MENU, MODE, ADJUSTMENT VALUE.
3. Reset the folder number and file number of still pictures.
(Setting the folder number is 100, and file number is 0.)
4. Clear the mechanism lock information.
5. Clear the service mode information contents.
6. Initialize the VIERA Link Physical Address.

The setting position of factory settings:

Name	Setting position
Mode switch	Recording mode

Service Manual

Diagrams and Replacement Parts List

High Definition Video Camera

Model No.

HDC-SD40P	HDC-SD40EG	HDC-SD41EB
HDC-SD40PC	HDC-SD40EP	HDC-TM40P
HDC-SD40PU	HDC-SD40GA	HDC-TM40PC
HDC-SD40EB	HDC-SD40GC	HDC-TM40PU
HDC-SD40EC	HDC-SD40GK	HDC-TM40EB
HDC-SD40EE	HDC-SD40GN	HDC-TM40GD
HDC-SD40EF	HDC-SD40GW	HDC-TM40GK
		HDC-TM41P

Vol. 1

Colour

[HDC-SD40]

(K).....Black Type

(W).....White Type (only EB/EC/EE/EF/EG/EP)

[HDC-SD41]

(H).....Glau Type

[HDC-TM40]

(K).....Black Type

[HDC-TM41]

(H).....Glau Type

Table of contents

S1. About Indication of The Schematic Diagram.....	S-1	S7.2. Packing Parts and Accessories Section.....	S-12
S1.1. Important Safety Notice.....	S-1		
S2. Voltage Chart	S-2		
S2.1. SD Holder P.C.B.....	S-2		
S3. Block Diagram.....	S-3		
S3.1. Overall Block Diagram	S-3		
S4. Schematic Diagram.....	S-4		
S4.1. Interconnection Diagram	S-4		
S4.2. SD Holder Schematic Diagram	S-5		
S5. Print Circuit Board.....	S-6		
S5.1. SD Holder P.C.B.....	S-6		
S6. Replacement Parts List.....	S-7		
S7. Exploded View	S-11		
S7.1. Frame and Casing Section.....	S-11		

S1. About Indication of The Schematic Diagram

S1.1. Important Safety Notice

COMPONENTS IDENTIFIED WITH THE MARK \triangle HAVE THE SPECIAL CHARACTERISTICS FOR SAFETY. WHEN REPLACING ANY OF THESE COMPONENTS USE ONLY THE SAME TYPE.

1. Although reference number of the parts is indicated on the P.C.B. drawing and/or schematic diagrams, it is NOT mounted on the P.C.B. when it is displayed with "\$" mark.
2. It is only the "Test Round" and no terminal (Pin) is available on the P.C.B. when the TP (Test Point) indicated as "●" mark.
3. The voltage being indicated on the schematic diagram is measured in "Standard-Playback" mode when there is no specify mode is mentioned.
4. Although the voltage and waveform available on here is measured with standard frame, it may be differ from actual measurement due to modification of circuit and so on.
5. The voltage being indicated here may be include observational-error (deviation) due to internal-resistance and/or reactance of equipment. Therefore, handle the value indicated on here as reference.
6. Use the parts number indicated on the Replacement Parts List .
7. Indication on Schematic diagrams:

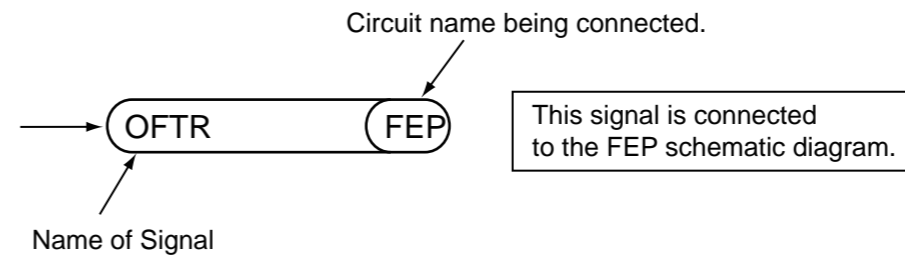

S2. Voltage Chart

Note) Indicated voltage values are the standard values for the unit measured by the DC electronic circuit tester (high-impedance) with the chassis taken as standard.
Therefore, there may exist some errors in the voltage values, depending on the internal impedance of the DC circuit tester.

S2.1. SD Holder P.C.B.

REF No.	PIN No.	POWER ON
QR6402	E	2.9
QR6402	C	-0.7
QR6402	B	3.2
Q3901	E	3.2
Q3901	C	3.2
Q3901	B	3.2

S3. Block Diagram

S3.1. Overall Block Diagram

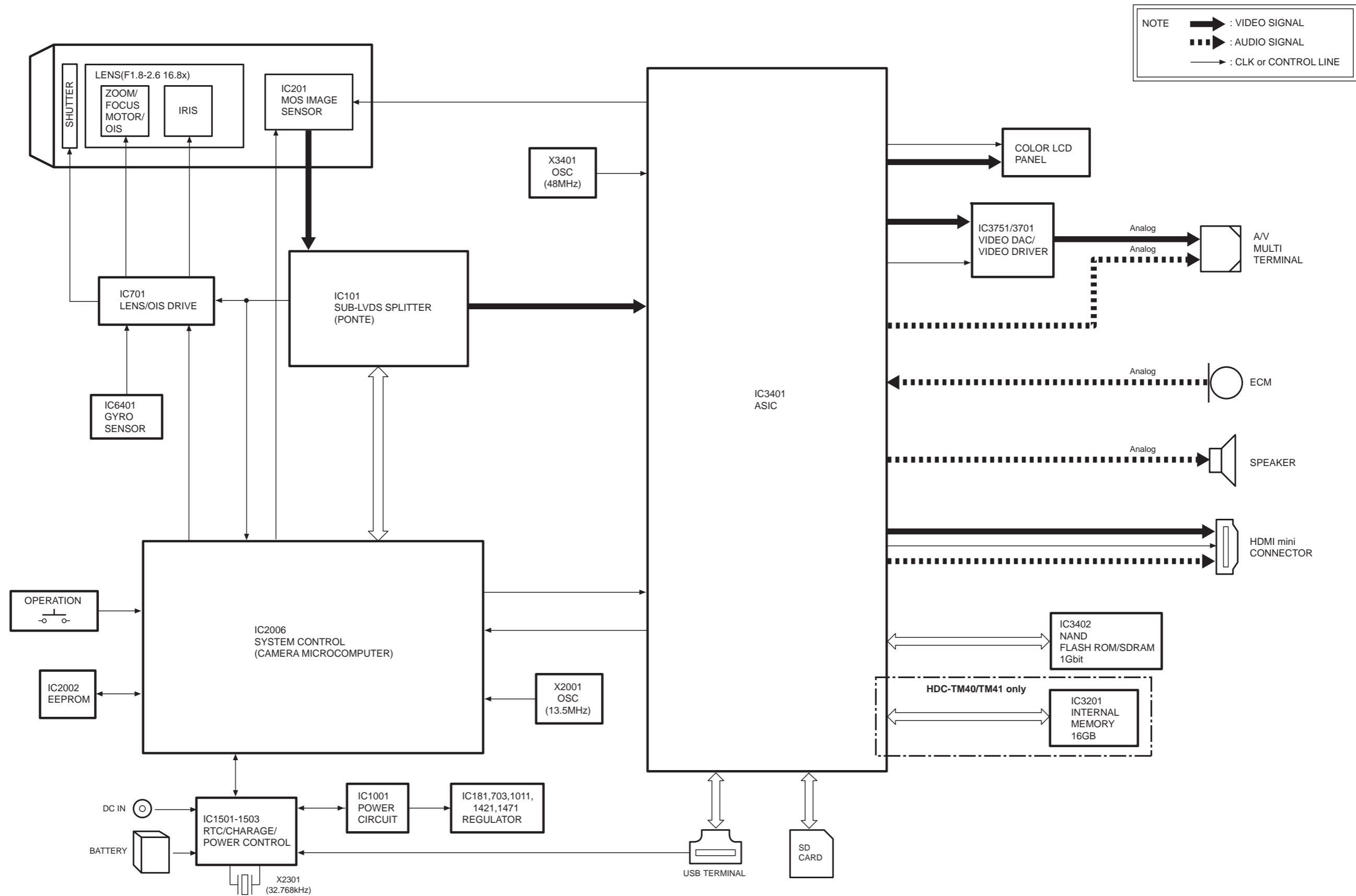

S4. Schematic Diagram

S4.1. Interconnection Diagram

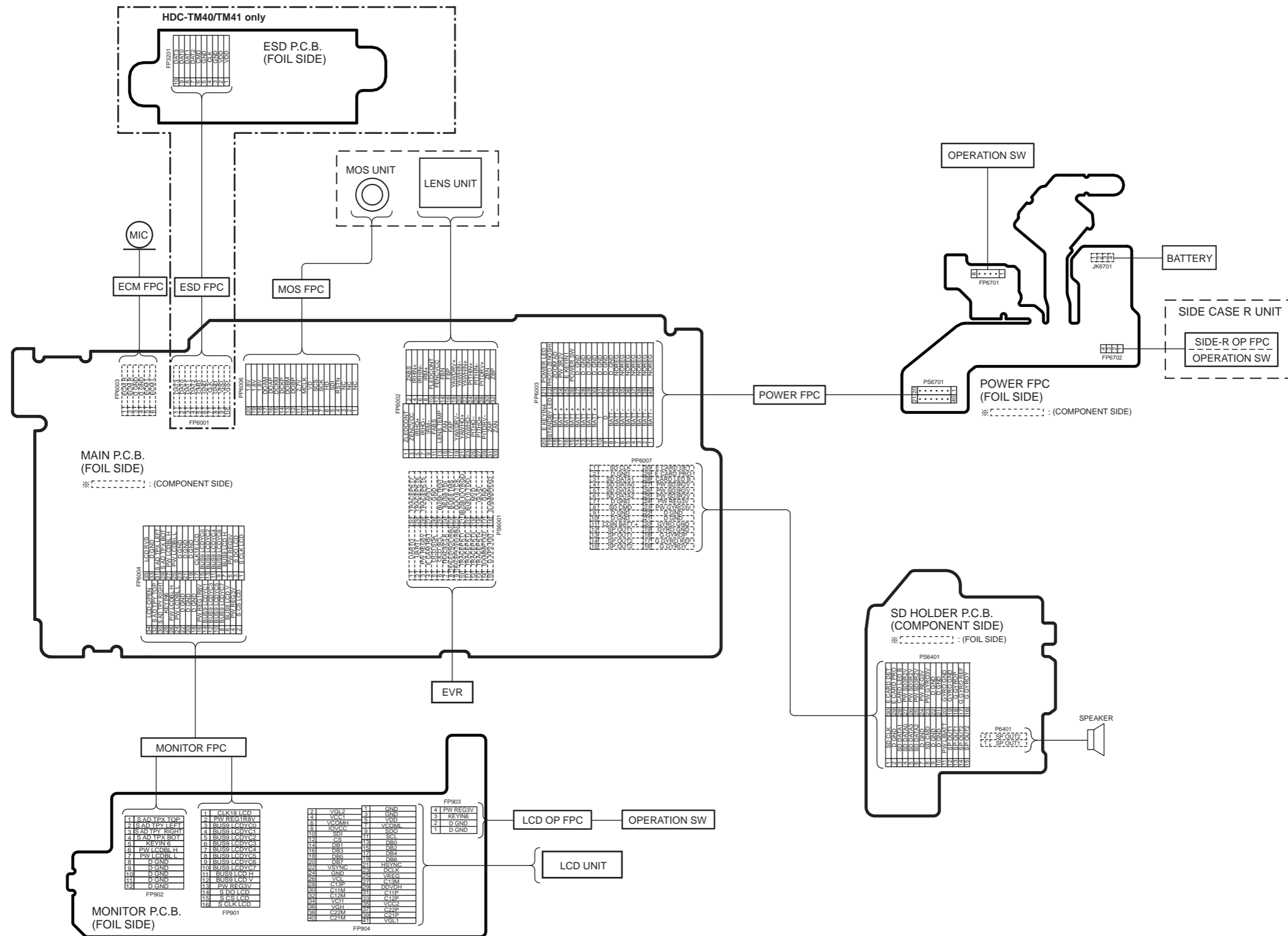

S4.2. SD Holder Schematic Diagram

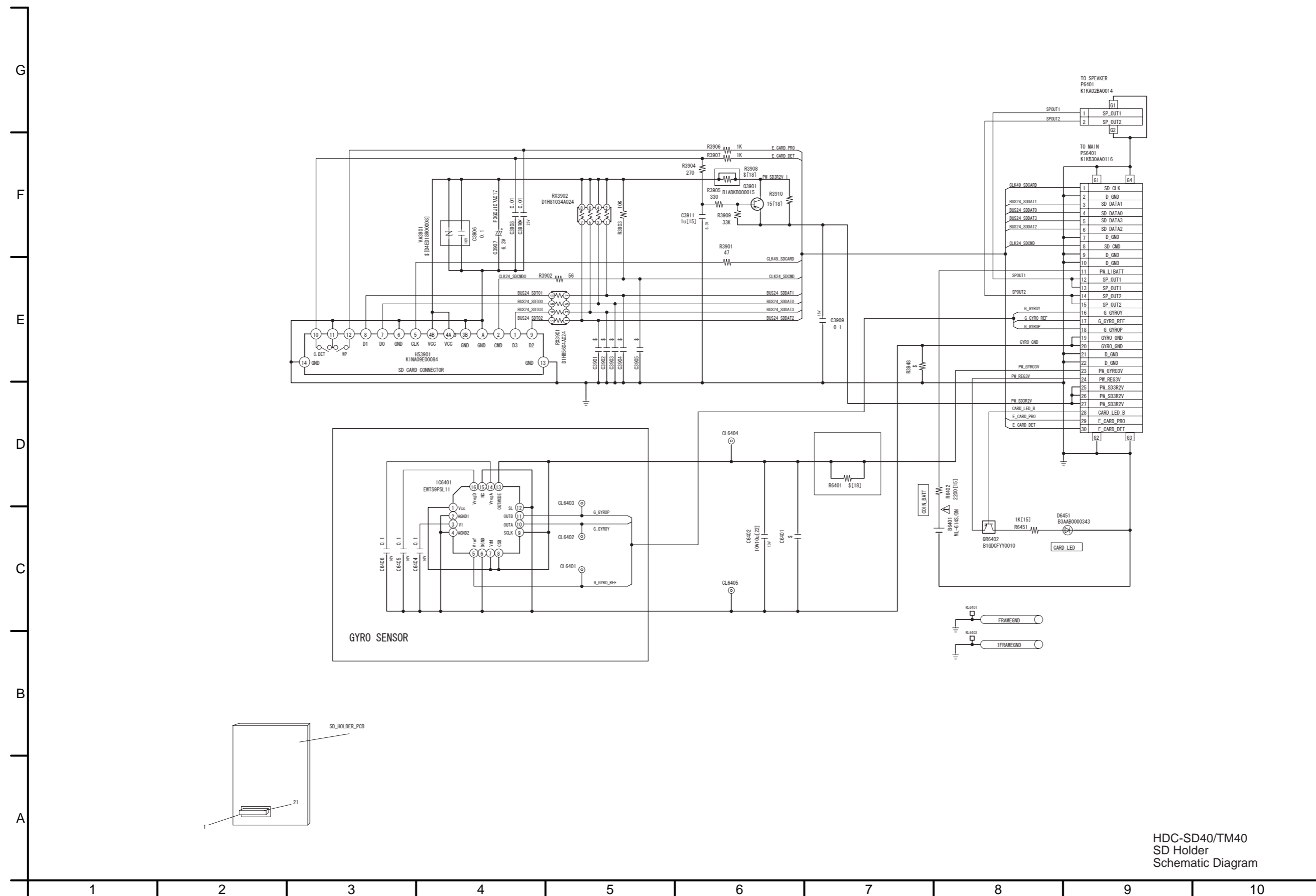

HDC-SD40/TM40
SD Holder
Schematic Diagram

S5. Print Circuit Board

S5.1. SD Holder P.C.B.

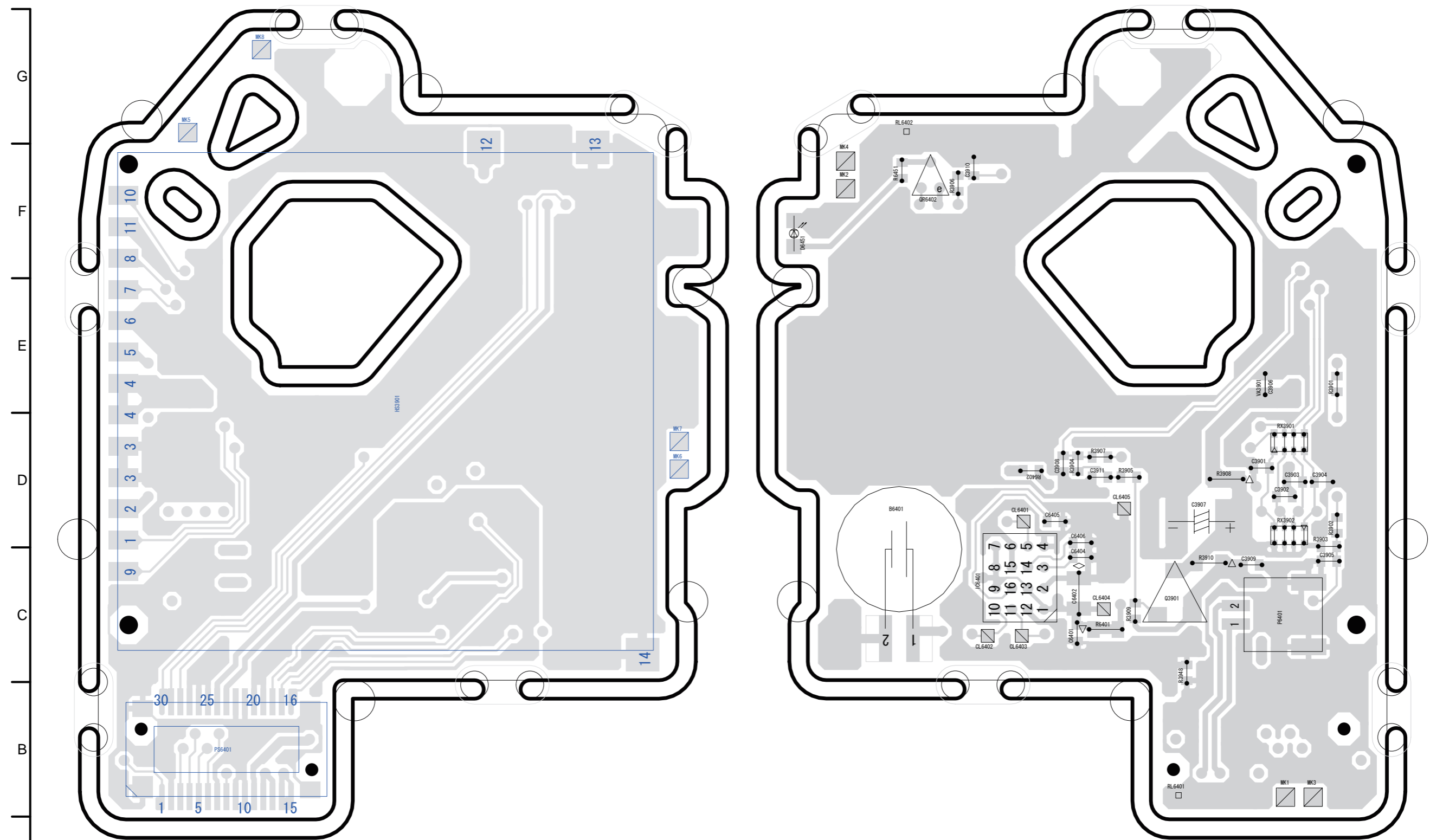

(Component Side)

(Foil Side)

HDC-SD40/TM40
SD Holder P.C.B.

S6. Replacement Parts List

- Note: 1.* Be sure to make your orders of replacement parts according to this list.
2. IMPORTANT SAFETY NOTICE
Components identified with the mark \triangle have the special characteristics for safety.
When replacing any of these components, use only the same type.
3. Unless otherwise specified,
All resistors are in OHMS, K=1,000 OHMS. All capacitors are in MICRO-FARADS (uf), P=uuF.
4. The marking (RTL) indicates the retention time is limited for this item. After the discontinuation of this assembly in production, it will no longer be available.

E.S.D. standards for Electrostatically Sensitive Devices, refer to “PREVENTION OF ELECTROSTATIC DISCHARGE (ESD) TO ELECTROSTATICALLY SENSITIVE (ES) DEVICES” section.

Ref.No.	Part No.	Part Name & Description	Pcs	Remarks	Ref.No.	Part No.	Part Name & Description	Pcs	Remarks
1	VYK4L96	TOP ORNAMENT UNIT	1	SD40EG-K,EB-K,EC-K,EE-K, EF-K,EP-K,GA-K,GC-K, GK-K,GN-K,GW-K,P-K,PC-K, PU-K, TM40EB-K,GD-K, GK-K,P-K,PC-K,PU-K	201	VXW1230	LENS UNIT	1	
1	VYK4V42	TOP ORNAMENT UNIT	1	SD40EG-W,EB-W,EC-W,EE-W, EF-W,EP-W	202	VXQ2055	MOS UNIT	1	
1	VYK4V22	TOP ORNAMENT UNIT	1	SD41EB-H, TM41P-H	203	VMX3811	CUSHION	1	
2	VYK4M15	SIDE CASE-L UNIT	1	SD40EG-K,EB-K,EC-K,EE-K, EF-K,EP-K,GA-K,GK-K, GN-K,GW-K,P-K,PC-K,PU-K, TM40EB-K,GD-K,GK-K,P-K, PC-K,PU-K	204	VDL2467	IR FILTER	1	
2	VYK4V21	SIDE CASE-L UNIT	1	SD40EG-W,EB-W,EC-W,EE-W, EF-W,EP-W	205	L6HA66NC0015	ZOOM MOTOR	1	
2	VYK4M15	SIDE CASE-L UNIT	1	SD40GC-K	206	L6HA66NC0016	FOCUS MOTOR	1	
2	VYK4V26	SIDE CASE-L UNIT	1	SD41EB-H, TM41P-H	B1	XQN16+B4FJK	SCREW	1	
3	VYK4L99	FRONT CASE UNIT	1	SD40EG-K,EB-K,EC-K,EE-K, EF-K,EP-K,GA-K,GK-K, GN-K,GW-K,P-K,PC-K,PU-K, TM40EB-K,GD-K,GK-K,P-K, PC-K,PU-K	B2	XQN16+B4FJK	SCREW	1	
3	VYK4V20	FRONT CASE UNIT	1	SD40EG-W,EB-W,EC-W,EE-W, EF-W,EP-W	B3	XQN16+B4FJK	SCREW	1	
3	VYK4L99	FRONT CASE UNIT	1	SD40GC-K	B4	XQN16+BJ5FJK	SCREW	1	
3	VYK4V25	FRONT CASE UNIT	1	SD41EB-H, TM41P-H	B5	XQN16+BJ4FJK	SCREW	1	(K)(H)
4	VXK1947	LENS ANGLE UNIT	1		B5	XQN16+BJ4FN	SCREW	1	(W)
5	VXK1948	TL FRAME UNIT	1		B6	XQN16+B5FN	SCREW	1	
6	VWJ2260	ESD FPC	1	TM40EB,GD,GK,P,PC,PU, TM41P	B6	XQN16+B5FN	SCREW	1	
7	VEP03H89G	ESD P.C.B.	1	TM40EB,GD,GK,P,PC,PU, TM41P	B7	XQN16+B5FN	SCREW	1	
8	VYK4L97	SIDE CASE-R UNIT	1	SD40EG-K,EB-K,EC-K,EE-K, EF-K,EP-K,GA-K,GK-K, GN-K,GW-K,P-K,PC-K,PU-K	B8	XQN16+BJ5FJK	SCREW	1	
8	VYK4V18	SIDE CASE-R UNIT	1	SD40EG-W,EB-W,EC-W,EE-W, EF-W,EP-W	B9	XQN16+BJ5FJK	SCREW	1	
8	VYK4L97	SIDE CASE-R UNIT	1	SD40GC-K	B10	VHD1919	SCREW	1	
8	VYK4V23	SIDE CASE-R UNIT	1	SD41EB-H	B11	VHD1919	SCREW	1	
8	VYK4S52	SIDE CASE-R UNIT	1	TM40EB-K,GD-K,GK-K,P-K, PC-K,PU-K	B12	VHD1907	SCREW	1	
8	VYK5A16	SIDE CASE-R UNIT	1	TM41P-H	B13	VHD1907	SCREW	1	
9	VSC6238	RADIATION PLATE	1		B14	VHD1907	SCREW	1	
10	VEP03J14BP	MAIN P.C.B. UNIT	1	(RTL) E.S.D. SD40EG, EB,EC,EF,EP, SD41EB	B15	VHD1907	SCREW	1	
10	VEP03J14BQ	MAIN P.C.B. UNIT	1	(RTL) E.S.D. SD40EE,GA,GC,GK,GN,GW	B16	VHD1919	SCREW	1	
10	VEP03J14BN	MAIN P.C.B. UNIT	1	(RTL) E.S.D. SD40P,PC,PU	B17	VHD1919	SCREW	1	
10	VEP03J14AP	MAIN P.C.B. UNIT	1	(RTL) E.S.D. TM40EB	B201	VHD2072	SCREW	1	
10	VEP03J14AN	MAIN P.C.B. UNIT	1	(RTL) E.S.D. TM40GD,P,PC,PU, TM41P	B202	VHD2073	SCREW	1	
10	VEP03J14AQ	MAIN P.C.B. UNIT	1	(RTL) E.S.D. TM40GK	B203	VHD2073	SCREW	1	
11	VEP03J15A	SD HOLDER P.C.B. UNIT	1	(RTL) E.S.D.	B204	VHD2073	SCREW	1	
					B205	VHD2073	SCREW	1	
					B206	VHD2073	SCREW	1	

HDC-SD40EG-K vol.1

Ref.No.	Part No.	Part Name & Description	Pcs	Remarks
△ 301	---	BATTERY PACK	1	SD40GK-K, TM40GK-K
302	K2KYYYY00141	USB CABLE	1	
303	K1HY12Y00008	MULTI D/RCA CABLE	1	
△ 304	K2CA2YY00070	AC CORD W/PLUG	1	SD40GK, TM40GK
△ 305	VSK0712	AC ADAPTOR	1	SD40EG,EB,EC,EE,EF,EP,GA, GC,GN,GW,PU, SD41EB, TM40EB,PU
△ 305	VSK0713	AC ADAPTOR	1	SD40GK, TM40GK
△ 305	VSK0711	AC ADAPTOR	1	SD40P,PC, TM40P,PC, TM41P
△ 305	VSK0714	AC ADAPTOR	1	TM40GD
306	VFF0721-S	CD-ROM	1	SD40EG,EB,EC,EE,EF,EP,GA, GC,GN,GW,P,PC,PU, SD41EB, TM40EB,GD,P,PC, PU, TM41P
306	VFF0722-S	CD-ROM	1	SD40GK, TM40GK
308	VPF1294	BAG, POLYETHYLENE	1	
△ 309	VQT3J99	OPERATING INSTRUCTIONS (GERMAN/TURKISH/ITALIAN/ DUTCH)	1	SD40EG
△ 309	VQT3K01	OPERATING INSTRUCTIONS (FRENCH)	1	SD40EG,EF
△ 309	VQT3K06	OPERATING INSTRUCTIONS (ENGLISH)	1	SD40EB, SD41EB, TM40EB
△ 309	VQT3K02	OPERATING INSTRUCTIONS (PORTUGUESE/SPANISH/ SWEDISH/DANISH/FRENCH)	1	SD40EC
△ 309	VQT3K10	OPERATING INSTRUCTIONS (RUSSIAN/UKRAINIAN)	1	SD40EE
△ 309	VQT3K04	OPERATING INSTRUCTIONS (ENGLISH/POLISH/CZECH/ HUNGARIAN)	1	SD40EP
△ 309	VQT3M56	OPERATING INSTRUCTIONS (THAI/ CHINESE(TRADITIONAL)/ HINDI)	1	SD40GA,GW
△ 309	VQT3L18	OPERATING INSTRUCTIONS (ENGLISH)	1	SD40GA,GN,GW
△ 309	VQT3K07	OPERATING INSTRUCTIONS (ENGLISH)	1	SD40GC
△ 309	VQT3K08	OPERATING INSTRUCTIONS (ARABIC/PERSIAN)	1	SD40GC
△ 309	VQT3K11	OPERATING INSTRUCTIONS (CHINESE(SIMPLIFIED))	1	SD40GK, TM40GK
△ 309	VQT3J95	OPERATING INSTRUCTIONS (ENGLISH)	1	SD40P,PC, TM40P,PC, TM41P
△ 309	VQT3J96	OPERATING INSTRUCTIONS (CANADIAN FRENCH)	1	SD40PC, TM40PC
△ 309	VQT3J97	OPERATING INSTRUCTIONS (ENGLISH)	1	SD40PU, TM40PU
△ 309	VQT3J98	OPERATING INSTRUCTIONS (SPANISH)	1	SD40PU, TM40PU
△ 309	VQT3K12	OPERATING INSTRUCTIONS (KOREAN)	1	TM40GD
310	VPG2U86	PACKING CASE	1	SD40EG-K,EB-K,EC-K,EE-K, EF-K,EP-K,GA-K,GN-K,PU-K
310	VYQ6508	PACKING CASE UNIT	1	SD40EG-W,EB-W,EC-W,EE-W, EF-W,EP-W
310	VPG2V90	PACKING CASE	1	SD40GC-K
310	VYQ6497	PACKING CASE UNIT	1	SD40GK-K
310	VYQ6771	PACKING CASE UNIT	1	SD40GW-K
310	VPG2U85	PACKING CASE	1	SD40P-K,PC-K
310	VPG2U87	PACKING CASE	1	SD41EB-H
310	VPG2U89	PACKING CASE	1	TM40EB-K,GD-K,PU-K
310	VYQ6498	PACKING CASE UNIT	1	TM40GK-K
310	VPG2U88	PACKING CASE	1	TM40P-K,PC-K
310	VPG2W35	PACKING CASE	1	TM41P-H
311	VPN6972	PAD	1	EXCEPT SD40GC
311	VPN6994	PAD	1	SD40GC
312	VPF1388	PROTECT BAG	1	
317	VPQ0308	PROTECT SHEET	1	SD40EG,EB,EC,EE,EF,EP,GC, GK,GN,P,PC,PU, SD41EB, TM40EB,GD,GK,P,PC,PU, TM41P
318	VFF0780	CD-ROM(O/I)	1	SD40EG,EC,EF,EP
318	VFF0786	CD-ROM(O/I)	1	SD40EE,GA,GN
318	VFF0781	CD-ROM(O/I)	1	SD40GC

Ref.No.	Part No.	Part Name & Description	Pcs	Remarks
△ 319	K2CA2CA00025	AC CORD W/PLUG	1	SD40P,PC,PU, TM40P,PC,PU, TM41P
△ 320	K2CJ29A00002	AC CORD W/PLUG	1	SD40GN
△ 321	K2CQ29A00002	AC CORD W/PLUG	1	SD40EG,EC,EE,EF,EP,GA,GC, GW
△ 322	K2CR29A00001	AC CORD W/PLUG	1	TM40GD
△ 323	K2CT39A00002	AC CORD W/PLUG	1	SD40EB,GA,GC,GW, SD41EB, TM40EB

S7. Exploded View

S7.1. Frame and Casing Section

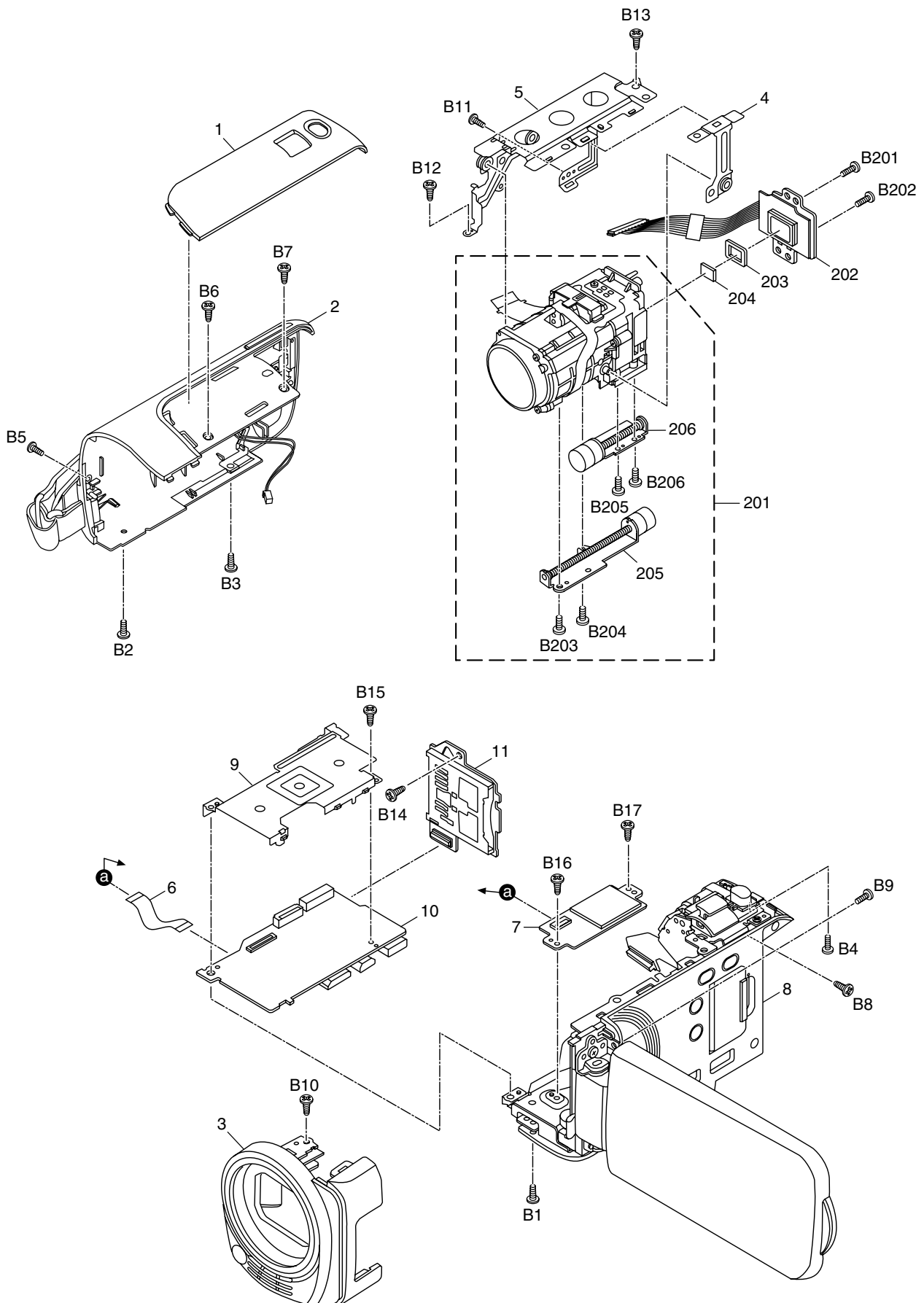

S7.2. Packing Parts and Accessories Section

