

Service Manual

High Definition Video Camera

AVCHD™

DOLBY
DIGITAL
STEREO CREATOR

SD
XC

HDMI VIERA Link™ 3D

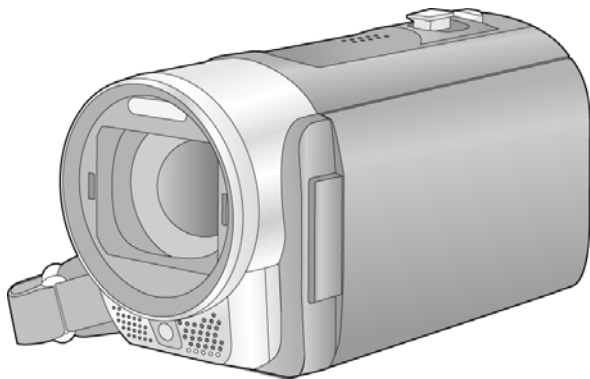

Model No. **HDC-SD90P**

HDC-SD90PC

HDC-SD90EB

HDC-SD90EC

HDC-SD90EE

HDC-SD90EF

HDC-SD90EG

HDC-SD90EP

HDC-SD90GC

HDC-SD90GN

HDC-SD90GK

HDC-SD99EG

HDC-TM90P

HDC-TM90PC

HDC-TM90PU

HDC-TM90GK

HDC-TM99EG

Vol. 1

Colour

(K).....Black Type

(S).....Silver Type (only HDC-SD99EG)

(H).....Glaz Type (only HDC-SD90EB)

Panasonic®

© Panasonic Corporation 2011 Unauthorized copying and distribution is a violation of law.

WARNING

This service information is designed for experienced repair technicians only and is not designed for use by the general public. It does not contain warnings or cautions to advise non-technical individuals of potential dangers in attempting to service a product. Products powered by electricity should be serviced or repaired only by experienced professional technicians. Any attempt to service or repair the product or products dealt with in this service information by anyone else could result in serious injury or death.

TABLE OF CONTENTS

	PAGE		PAGE
1 Safety Precautions	3	10 Factory Setting	38
1.1. General Guidelines	3	10.1. How To Turn On The Factory Settings?	38
1.2. Leakage Current Cold Check	3	10.2. What Is The Factory Settings?	39
1.3. Leakage Current Hot Check (See Figure 1.)	3		
1.4. How to Discharge the Capacitor on Flash P.C.B.	4		
2 Warning	5		
2.1. Prevention of Electrostatic Discharge (ESD) to Electrostatically Sensitive (ES) Devices	5		
2.2. How to Recycle the Lithium Ion Battery (U.S. Only)	5		
2.3. Caution for AC Cord (For EB/GC)	6		
2.4. How to Replace the Lithium Battery	7		
3 Service Navigation	8		
3.1. Introduction	8		
3.2. General Description About Lead Free Solder (PbF)	8		
3.3. Important Notice 1:(Other than U.S.A. and Canadian Market)	8		
3.4. How to Define the Model Suffix (NTSC or PAL model)	9		
3.5. Formatting	10		
4 Specifications	11		
5 Location of Controls and Components	13		
6 Service Mode	17		
6.1. Built-in Memory Self Check Execution (HDC- TM90/TM99 only)	18		
6.2. Lock Search History Indication	18		
6.3. Power ON Self Check Result Display	19		
6.4. Forced full flash emission	19		
6.5. Erasing the lock histories	20		
6.6. Erasing the internal media management information (HDC-TM90/TM99 only)	20		
6.7. Camera data indications while the video playback	21		
7 Service Fixture & Tools	22		
7.1. When Replacing the Main P.C.B.	22		
7.2. Service Position	22		
8 Disassembly and Assembly Instructions	24		
8.1. Disassembly Flow Chart for the Unit	24		
8.2. PCB Location	24		
8.3. Disassembly Procedure for the Unit	25		
9 Measurements and Adjustments	36		
9.1. Electric Adjustment	36		

1 Safety Precautions

1.1. General Guidelines

1. IMPORTANT SAFETY NOTICE

There are special components used in this equipment which are important for safety. These parts are marked by

 in the Schematic Diagrams, Circuit Board Layout, Exploded Views and Replacement Parts List. It is essential that these critical parts should be replaced with manufacturer's specified parts to prevent X-RADIATION, shock, fire, or other hazards. Do not modify the original design without permission of manufacturer.

2. An Isolation Transformer should always be used during the servicing of AC Adaptor whose chassis is not isolated from the AC power line. Use a transformer of adequate power rating as this protects the technician from accidents resulting in personal injury from electrical shocks. It will also protect AC Adaptor from being damaged by accidental shorting that may occur during servicing.
3. When servicing, observe the original lead dress. If a short circuit is found, replace all parts which have been overheated or damaged by the short circuit.
4. After servicing, see to it that all the protective devices such as insulation barriers, insulation papers shields are properly installed.
5. After servicing, make the following leakage current checks to prevent the customer from being exposed to shock hazards.

1.2. Leakage Current Cold Check

1. Unplug the AC cord and connect a jumper between the two prongs on the plug.
2. Measure the resistance value, with an ohmmeter, between the jumpered AC plug and each exposed metallic cabinet part on the equipment such as screwheads, connectors, control shafts, etc. When the exposed metallic part has a return path to the chassis, the reading should be between $1\text{ M}\Omega$ and $5.2\text{ M}\Omega$. When the exposed metal does not have a return path to the chassis, the reading must be infinity.

1.3. Leakage Current Hot Check (See Figure 1.)

1. Plug the AC cord directly into the AC outlet. Do not use an isolation transformer for this check.
2. Connect a $1.5\text{ k}\Omega$, 10 W resistor, in parallel with a $0.15\text{ }\mu\text{F}$ capacitor, between each exposed metallic part on the set and a good earth ground, as shown in Figure 1.
3. Use an AC voltmeter, with $1\text{ k}\Omega/\text{V}$ or more sensitivity, to measure the potential across the resistor.
4. Check each exposed metallic part, and measure the voltage at each point.
5. Reverse the AC plug in the AC outlet and repeat each of the above measurements.
6. The potential at any point should not exceed 0.75 V RMS . A leakage current tester (Simpson Model 229 or equivalent) may be used to make the hot checks, leakage current must not exceed $1/2\text{ mA}$. In case a measurement is outside of the limits specified, there is a possibility of a shock hazard, and the equipment should be repaired and rechecked before it is returned to the customer.

Hot-Check Circuit

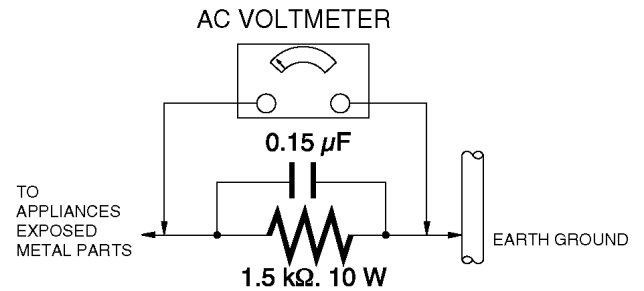

Figure. 1

1.4. How to Discharge the Capacitor on Flash P.C.B.

CAUTION:

1. Be sure to discharge the capacitor on FLASH P.C.B..
2. Be careful of the high voltage circuit on FLASH P.C.B. when servicing.

Before disassembling, perform "6.4. Forced full flash emission" for discharging capacitor.
The capacitor also can be discharged according to the following procedures.

[Discharging Procedure]

1. Refer to the disassemble procedure and Remove the necessary parts/unit.
2. Put the insulation tube onto the lead part of Resistor (ERG5SJ102:1k Ω /5W).
(an equivalent type of resistor may be used.)
3. Put the resistor between both terminals of capacitor on FLASH P.C.B. for approx. 5 seconds.
4. After discharging confirm that the capacitor voltage is lower than 10V using a voltmeter.

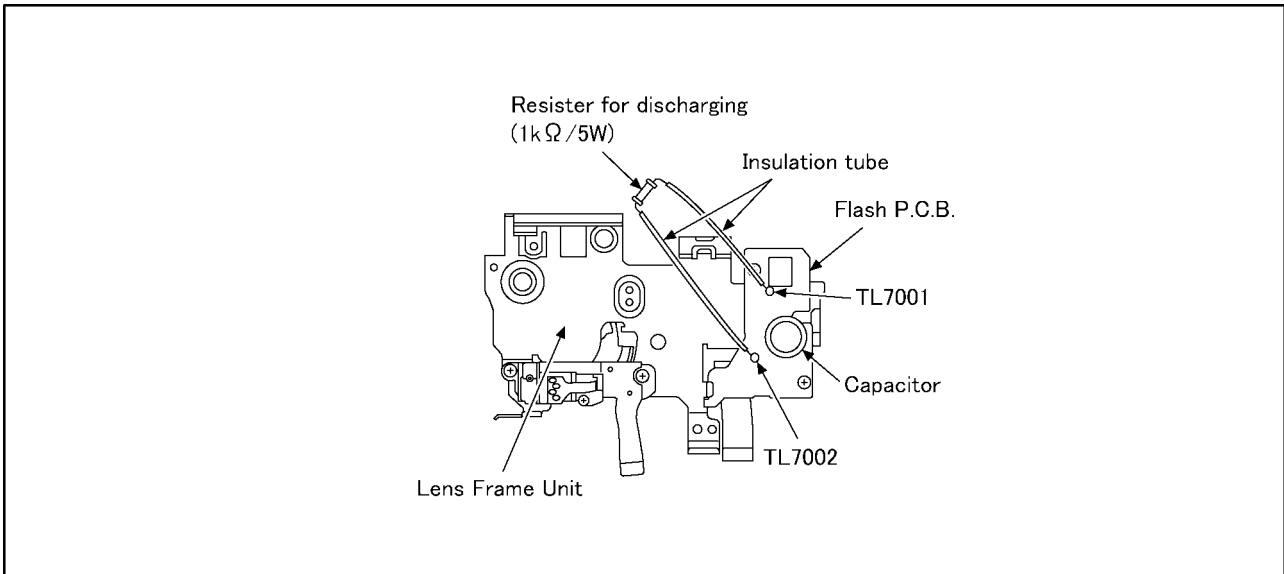

Fig. F1

2 Warning

2.1. Prevention of Electrostatic Discharge (ESD) to Electrostatically Sensitive (ES) Devices

Some semiconductor (solid state) devices can be damaged easily by static electricity. Such components commonly are called Electrostatically Sensitive (ES) Devices. Examples of typical ES devices are integrated circuits and some field-effect transistors and semiconductor "chip" components. The following techniques should be used to help reduce the incidence of component damage caused by electrostatic discharge (ESD).

1. Immediately before handling any semiconductor component or semiconductor-equipped assembly, drain off any ESD on your body by touching a known earth ground. Alternatively, obtain and wear a commercially available discharging ESD wrist strap, which should be removed for potential shock reasons prior to applying power to the unit under test.
2. After removing an electrical assembly equipped with ES devices, place the assembly on a conductive surface such as aluminum foil, to prevent electrostatic charge buildup or exposure of the assembly.
3. Use only a grounded-tip soldering iron to solder or unsolder ES devices.
4. Use only an antistatic solder removal device. Some solder removal devices not classified as "antistatic (ESD protected)" can generate electrical charge sufficient to damage ES devices.
5. Do not use freon-propelled chemicals. These can generate electrical charges sufficient to damage ES devices.
6. Do not remove a replacement ES device from its protective package until immediately before you are ready to install it. (Most replacement ES devices are packaged with leads electrically shorted together by conductive foam, aluminum foil or comparable conductive material).
7. Immediately before removing the protective material from the leads of a replacement ES device, touch the protective material to the chassis or circuit assembly into which the device will be installed.

CAUTION :

Be sure no power is applied to the chassis or circuit, and observe all other safety precautions.

8. Minimize bodily motions when handling unpackaged replacement ES devices. (Otherwise harmless motion such as the brushing together of your clothes fabric or the lifting of your foot from a carpeted floor can generate static electricity (ESD) sufficient to damage an ES device).

2.2. How to Recycle the Lithium Ion Battery (U.S. Only)

ENGLISH



A lithium ion/polymer battery that is recyclable powers the product you have purchased. Please call 1-800-8-BATTERY for information on how to recycle this battery.

FRANÇAIS



L'appareil que vous vous êtes procuré est alimenté par une batterie au lithium-ion/lithium-polymère. Pour des renseignements sur le recyclage de la batterie, veuillez composer le 1-800-8-BATTERY.

2.3. Caution for AC Cord (For EB/GC)

2.3.1. Information for Your Safety

IMPORTANT

Your attention is drawn to the fact that recording of pre-recorded tapes or discs or other published or broadcast material may infringe copyright laws.

WARNING

To reduce the risk of fire or shock hazard, do not expose this equipment to rain or moisture.

CAUTION

To reduce the risk of fire or shock hazard and annoying interference, use the recommended accessories only.

FOR YOUR SAFETY

DO NOT REMOVE THE OUTER COVER

To prevent electric shock, do not remove the cover. No user serviceable parts inside. Refer servicing to qualified service personnel.

2.3.2. Caution for AC Mains Lead

For your safety, please read the following text carefully.

This appliance is supplied with a moulded three-pin mains plug for your safety and convenience.

A 5-ampere fuse is fitted in this plug.

Should the fuse need to be replaced please ensure that the replacement fuse has a rating of 5 amperes and it is approved by ASTA or BSI to BS1362

Check for the ASTA mark or the BSI mark on the body of the fuse.



If the plug contains a removable fuse cover you must ensure that it is refitted when the fuse is replaced.

If you lose the fuse cover, the plug must not be used until a replacement cover is obtained.

A replacement fuse cover can be purchased from your local Panasonic Dealer.

If the fitted moulded plug is unsuitable for the socket outlet in your home then the fuse should be removed and the plug cut off and disposed of safely.

There is a danger of severe electrical shock if the cut off plug is inserted into any 13-ampere socket.

If a new plug is to be fitted please observe the wiring code as shown below.

If in any doubt, please consult a qualified electrician.

2.3.2.1. Important

The wires in this mains lead are coloured in accordance with the following code:

Blue	Neutral
Brown	Live

As the colours of the wires in the mains lead of this appliance may not correspond with the coloured markings identifying the terminals in your plug, proceed as follows:

The wire which is coloured BLUE must be connected to the terminal in the plug which is marked with the letter N or coloured BLACK.

The wire which is coloured BROWN must be connected to the terminal in the plug which is marked with the letter L or coloured RED.

Under no circumstances should either of these wires be connected to the earth terminal of the three pin plug, marked with the letter E or the Earth Symbol.

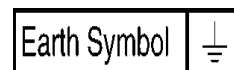

2.3.2.2. Before Use

Remove the Connector Cover as follows.

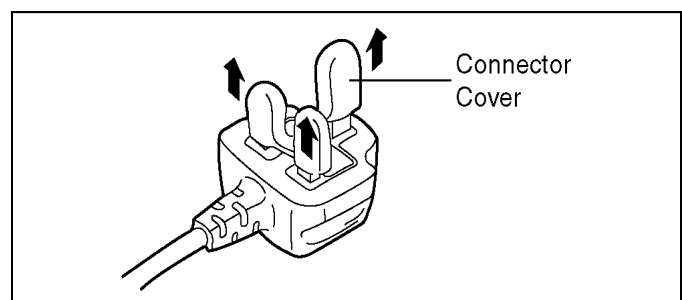

2.3.2.3. How to Replace the Fuse

1. Remove the Fuse Cover with a screwdriver.

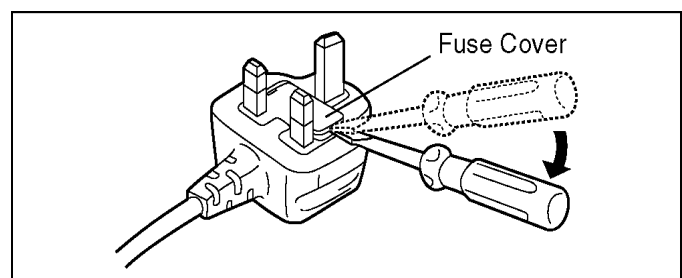

2. Replace the fuse and attach the Fuse cover.

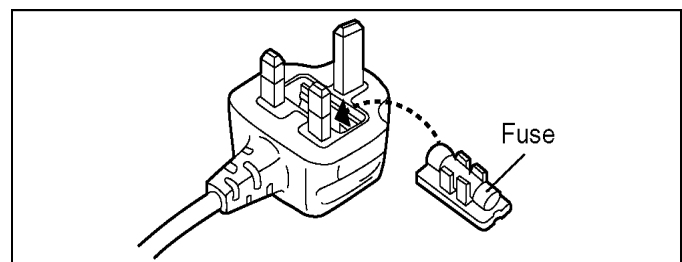

2.4. How to Replace the Lithium Battery

2.4.1. Replacement Procedure

1. Remove the SD HOLDER P.C.B.. (Refer to Disassembly Procedures.)
2. Remove the Lithium battery (Ref. No. "B6401" at foil side of SD HOLDER P.C.B.) and then replace it into new one.

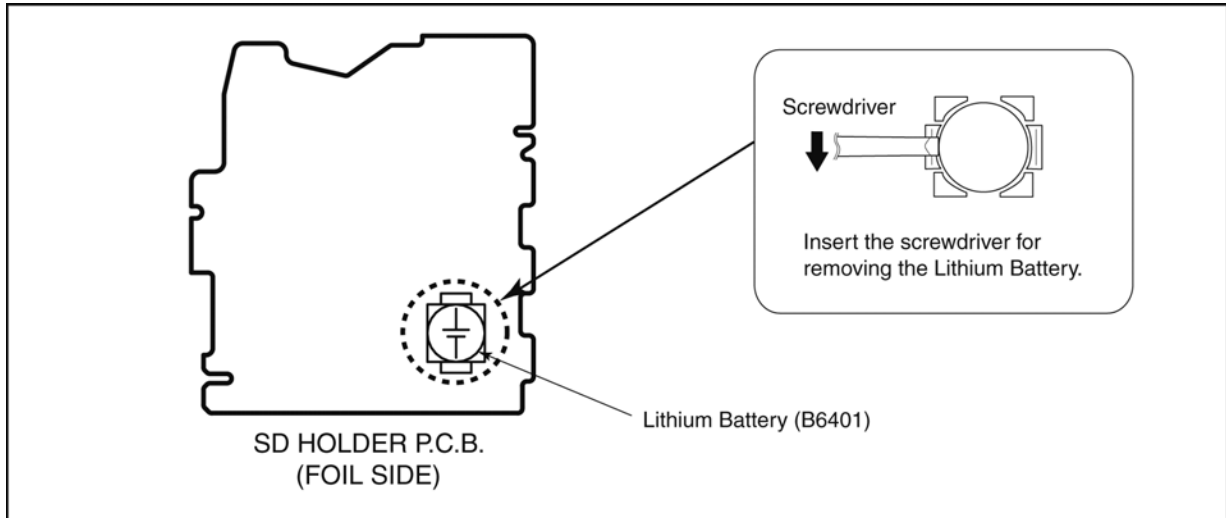

NOTE:

This Lithium battery is a critical component.

(Type No.: ML-614S/ZTK **Manufactured by Energy Company, Panasonic Corporation**)

It must never be subjected to excessive heat or discharge.

It must therefore only be fitted in requirement designed specifically for its use.

Replacement batteries must be of same type and manufacture.

They must be fitted in the same manner and location as the original battery, with the correct polarity contacts observed.

Do not attempt to re-charge the old battery or re-use it for any other purpose.

It should be disposed of in waste products destined for burial rather than incineration.

(For English)

CAUTION

Danger of explosion if battery is incorrectly replaced.

Replace only with the same or equivalent type recommended by the manufacturer.

Dispose of used batteries according to the manufacturer's instructions.

(For German)

ACHTUNG

Explosionsgefahr bei falschem Anbringen der Batterie. Ersetzen Sie nur mit einem äquivalentem vom Hersteller empfohlenem Typ.

Behandeln Sie gebrauchte Batterien nach den Anweisungen des Herstellers.

(For French)

MISE EN GARDE

Une batterie de remplacement inappropriée peut exploser. Ne remplacez qu'avec une batterie identique ou d'un type recommandé par le fabricant. L'élimination des batteries usées doit être faite conformément aux instructions du fabricant.

NOTE:

Above caution is applicable for a battery pack which is for HDC-SD90/SD99/TM90/TM99 series, as well.

1. Battery Pack for this model.

3 Service Navigation

3.1. Introduction

This service manual contains technical information, which allow service personnel's to understand and service this model.

Please place orders using the parts list and not the drawing reference numbers.

If the circuit is changed or modified, the information will be followed by service manual to be controlled with original service manual.

3.2. General Description About Lead Free Solder (PbF)

The lead free solder has been used in the mounting process of all electrical components on the printed circuit boards used for this equipment in considering the globally environmental conservation.

The normal solder is the alloy of tin (Sn) and lead (Pb). On the other hand, the lead free solder is the alloy mainly consists of tin (Sn), silver (Ag) and Copper (Cu), and the melting point of the lead free solder is higher approx.30°C (86°F) more than that of the normal solder.

Distinction of P.C.B. Lead Free Solder being used

The letter of "PbF" is printed either foil side or components side on the P.C.B. using the lead free solder.(See right figure)
--

PbF

Service caution for repair work using Lead Free Solder (PbF)

- The lead free solder has to be used when repairing the equipment for which the lead free solder is used.
(Definition: The letter of "PbF" is printed on the P.C.B. using the lead free solder.)
- To put lead free solder, it should be well molten and mixed with the original lead free solder.
- Remove the remaining lead free solder on the P.C.B. cleanly for soldering of the new IC.
- Since the melting point of the lead free solder is higher than that of the normal lead solder, it takes the longer time to melt the lead free solder.
- Use the soldering iron (more than 70W) equipped with the temperature control after setting the temperature at 350±30°C (662±86°F).

Recommended Lead Free Solder (Service Parts Route.)

- The following 3 types of lead free solder are available through the service parts route.
RFKZ03D01KS------(0.3mm 100g Reel)
RFKZ06D01KS------(0.6mm 100g Reel)
RFKZ10D01KS------(1.0mm 100g Reel)

Note

* Ingredient: tin (Sn) 96.5%, silver (Ag) 3.0%, Copper (Cu) 0.5%, Cobalt (Co) / Germanium (Ge) 0.1 to 0.3%

3.3. Important Notice 1:(Other than U.S.A. and Canadian Market)

1. The service manual does not contain the following information, because of the impossibility of servicing at component level without concerned equipment/facilities.
 - a. Schematic diagram, Block Diagram and P.C.B. layout of MAIN P.C.B..
 - b. Parts list for individual parts for MAIN P.C.B..

When a part replacement is required for repairing MAIN P.C.B., replace as an assembled parts. (Main P.C.B.)

2. The following category is /are recycle module part. Please send it/them to Central Repair Center.

- MAIN P.C.B. (VEP03J13CN: HDC-SD90P/PC)
- MAIN P.C.B. (VEP03J13CP: HDC-SD90EB/EC/EF/EG/EP, SD99EG)
- MAIN P.C.B. (VEP03J13CQ: HDC-SD90EE/GC/GK/GN)
- MAIN P.C.B. (VEP03J13BN: HDC-TM90P/PC/PU)
- MAIN P.C.B. (VEP03J13BP: HDC-TM99EG)
- MAIN P.C.B. (VEP03J13BQ: HDC-TM90GK)

3.4. How to Define the Model Suffix (NTSC or PAL model)







There are eight kinds of HDC-SD90/SD99/TM90/TM99.

- a) HDC-TM90 (Japan domestic model)
- b) HDC-SD90P, TM90P
- c) HDC-SD90PC, TM90PC
- d) HDC-SD90EB/EC/EF/EG/EP/GN
- e) HDC-SD99EG, TM99EG
- f) HDC-SD90EE
- g) HDC-SD90GK, TM90GK
- h) HDC-SD90GC, TM90PU

What is the difference is that the "INITIAL SETTING" data which is stored in Flash ROM mounted on Main P.C.B..

3.4.1. Defining methods:

To define the model suffix to be serviced, refer to the rating label and caution label which are putted on the Unit.

<p>a) HDC-TM90 (Japan domestic model) The nameplate for this model shows the following Safety registration mark.</p> 
<p>b) HDC-SD90P, TM90P The nameplate for these models show the following Safety registration mark.</p> 
<p>c) HDC-SD90PC, TM90PC The nameplate for these models show the following Safety registration mark.</p> 
<p>d) HDC-SD90EB/EC/EF/EG/EP/GN The nameplate for these models show the following Safety registration mark.</p> 
<p>e) HDC-SD99EG, TM99EG The nameplate for these models show the following Safety registration mark.</p> 
<p>f) HDC-SD90EE The nameplate for this model shows the following Safety registration mark.</p> 
<p>g) HDC-SD90GK, TM90GK The nameplate for these models show the following Safety registration mark.</p> 
<p>h) HDC-SD90GC, TM90PU The nameplate for these models show the following Safety registration mark.</p>

NOTE:

After replacing the MAIN P.C.B., be sure to achieve adjustment.

The adjustment instruction is available at "software download" on the "Support Information from NWBG/VDBG-AVC" web-site in "TSN system", together with Maintenance software.

3.5. Formatting

HDC-SD90 HDC-SD99

[FORMAT CARD]

Please be aware that if a medium is formatted, then all the data recorded on the medium will be erased and cannot be restored. Back up important data on a PC, DVD disc etc.

- When formatting is complete, touch [EXIT] to exit the message screen.
 - Perform a physical formatting of the SD card when the SD card is to be disposed/ transferred.
-
- Do not turn this unit off or remove the SD card, while formatting. Do not expose the unit to vibrations or shock.

Use this unit to format media.

Do not format an SD card using any other equipment such as a PC. The card may not be used on this unit.

HDC-TM90 HDC-TM99

[FORMAT MEDIA]

Please be aware that if a medium is formatted, then all the data recorded on the medium will be erased and cannot be restored. Back up important data on a PC, DVD disc etc.

- 1 Touch [FORMAT MEDIA].
- 2 Touch [SD CARD] or [Built-inMemory].

- When formatting is complete, touch [EXIT] to exit the message screen.
 - Perform a physical formatting of the SD card when the SD card is to be disposed/ transferred.
 - Perform a physical formatting of the built-in memory when this unit is to be disposed/ transferred.
-
- Do not turn this unit off or remove the SD card, while formatting. Do not expose the unit to vibrations or shock.

Use this unit to format media.

Formatting built-in memory is only available with this unit.

Do not format an SD card using any other equipment such as a PC. The card may not be used on this unit.

When disposing of or giving away the SD card, note that:

- Formatting and deletion of this unit or computer only changes the file management information and does not completely delete the data in the SD card.
- It is recommended that the SD card is physically destroyed or the SD card is physically formatted using this unit when disposing of or giving away the SD card.

HDC-SD90 HDC-SD99

To physically format the SD card, connect the unit via the AC adaptor, select [SETUP] → [FORMAT CARD] → [YES] from the menu, and then press and hold the recording start/stop button on the screen below for about 3 seconds. When the SD card data deletion screen appears, select [YES], and then follow the on-screen instructions.



HDC-TM90 HDC-TM99

To physically format the SD card, connect the unit via the AC adaptor, select [SETUP] → [FORMAT MEDIA] → [SD CARD] from the menu, and then press and hold the recording start/stop button on the screen below for about 3 seconds. When the SD card data deletion screen appears, select [YES], and then follow the on-screen instructions.

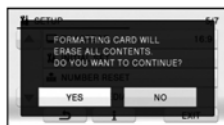

- The customer is responsible for the management of the data in the SD card.

HDC-TM90 HDC-TM99

When disposing of or giving away this unit, note that:

- Formatting and deletion simply change the file management information and cannot be used to completely erase the data in built-in memory of this unit. The data can be recovered using commercially available software or the like.
- We recommend that you physically format the built-in memory before disposing of or giving away this unit.

To physically format the built-in memory, connect the unit via the AC adaptor, select [SETUP] → [FORMAT MEDIA] → [Built-inMemory] from the menu, and then press and hold the recording start/stop button on the screen below for about 3 seconds. When the built-in memory data deletion screen appears, select [YES], and then follow the on-screen instructions.



- Please look after the data in your built-in memory carefully. Panasonic will not be held responsible in the unlikely case that private data is divulged.

4 Specifications

High Definition Video Camera

Information for your safety

Power source:	DC 5.0 V (When using AC adaptor) DC 3.6 V (When using battery)	
Power consumption:	Recording: 5.2 W	Charging: 7.7 W

Signal system:

1080/60p, 1080/60i, 540/30p (NTSC areas)
1080/50p, 1080/50i, 540/25p (PAL areas)

Recording format:

[1080/60p]; Original format (NTSC areas)
[1080/50p]; Original format (PAL areas)
[HA]/[HG]/[HX]/[HE]; AVCHD format compliant
[iFrame]; MPEG-4 AVC file format compliant (.MP4)

Image sensor:

1/4.1" 1MOS image sensor

Total; 3320 K

Effective pixels;

Motion picture; 2610 K to 1940 K (16:9)

Still picture; 2240 K to 2180 K (4:3), 2520 K to 2090 K (3:2), 2610 K to 1940 K (16:9)

Lens:

Auto Iris, 21× Optical Zoom, F1.8 to F3.5

Focal length; 2.82 mm to 59.2 mm

Macro (Full range AF)

35 mm equivalent;

Motion picture; 28 mm to 729 mm (16:9)

Still picture; 34.2 mm to 729 mm (4:3), 31.7 mm to 730 mm (3:2), 28 mm to 729 mm (16:9)

Minimum focus distance;

Normal; Approx. 3 cm (1.2") (Wide)/Approx. 1.5 m (4.9 feet) (Tele)

Tele macro; Approx. 60 cm (24") (Tele)

Intelligent auto Macro; Approx. 1 cm (0.4") (Wide)/Approx. 60 cm (24") (Tele)

Filter diameter:

41.5 mm (for the step up ring)

Zoom:

i.Zoom OFF 26×, 40× i.Zoom, 60×/1500× Digital Zoom

(Using image sensor effective area)

Image stabilizer function:

Optical (Hybrid Optical Image Stabilizer, Active Mode, Optical Image Stabilizer Lock Function)

Monitor:

3" wide LCD monitor (Approx. 230 K dots)

Microphone:

Stereo (with a zoom microphone function)

Speaker:

1 round speaker, dynamic type

White balance adjustment:

Auto tracking white balance system

Standard illumination:

1,400 lx

Minimum required illumination:

Approx. 4 lx (1/30 with Low light mode in the Scene mode) (NTSC areas)

Approx. 1 lx with the Color Night Rec function (NTSC areas)

Approx. 4 lx (1/25 with Low light mode in the Scene mode) (PAL areas)

Approx. 1 lx with the colour night view function (NTSC areas)

AV multi connector video output level:

Component video output level;

Y; 1.0 Vp-p, 75 Ω

Pb; 0.7 Vp-p, 75 Ω

Pr; 0.7 Vp-p, 75 Ω

AV video output level;

1.0 Vp-p, 75 Ω, NTSC system (NTSC areas)

1.0 Vp-p, 75 Ω, PAL system (PAL areas)

HDMI mini connector video output level:

HDMI™ (x.v.Color™) 1080p/1080i/480p (NTSC areas)

HDMI™ (x.v.Colour™) 1080p/1080i/576p (PAL areas)

AV multi connector audio output level (Line):

316 mV, 600 Ω, 2 ch

HDMI mini connector audio output level:

[1080/60p] (NTSC areas), [1080/50p] (PAL areas),

[AVCHD]; Dolby Digital/Linear PCM

[iFrame]; Linear PCM

MIC input:

-70 dBV (Mic sensitivity -50 dB equivalent, 0 dB=1 V/Pa, 1 kHz)

(Stereo mini jack)

USB:

Reader/writer function

SD card; Read only (No copyright protection support) (EB/EF/EG/EP areas)

SD card; Read/Write (No copyright protection support) (Other areas)

[HDC-TM90] [HDC-TM99]

Built-in memory; Read only

Hi-Speed USB (USB 2.0), USB terminal Type Mini AB

USB host function (for DVD burner)

Battery charging function (Charges from USB terminal when the main unit is off)

Flash:

Available range; Approx. 1.0 m to 2.5 m (3.3 feet to 8.2 feet)

Dimensions:

50.5 mm (W)×63 mm (H)×118.5 mm (D)

[1.98" (W)×2.48" (H)×4.66" (D)] (excluding projecting parts)

Mass (Weight):

[HDC-SD90] [HDC-SD99]

Approx. 244 g (Approx. 0.54 lbs.)

[without battery (supplied) and an SD card (optional)]

[HDC-TM90] [HDC-TM99]

Approx. 245 g (Approx. 0.54 lbs.)

[without battery (supplied)]

Mass (Weight) in operation:

[HDC-SD90] [HDC-SD99]

Approx. 288 g (Approx. 0.63 lbs.)

[with battery (supplied) and an SD card (optional)]

[HDC-TM90] [HDC-TM99]

Approx. 287 g (Approx. 0.63 lbs.)

[with battery (supplied)]

Operating temperature:

0 °C to 40 °C (32 °F to 104 °F)

Operating humidity:

10%RH to 80%RH

Battery operation time:

See "Charging and recording time"

■ 3D Conversion Lens (optional)

Lens:

F3.3 (f = 2.3 mm)

35 mm equivalent; 58 mm

Minimum recording distance; Approx. 1.2 m (3.9 feet)

Minimum illumination:

Approx. 28 lx (1/30 when [AUTO SLOW SHTR (3D)] is set to [ON]) (NTSC areas)

Approx. 28 lx (1/25 when [AUTO SLOW SHTR (3D)] is set to [ON]) (PAL areas)

■ Motion pictures

Recording media:

SD Memory Card (FAT12 and FAT16 system compliant)

SDHC Memory Card (FAT32 system compliant)

SDXC Memory Card (exFAT system compliant)

Refer to "Recording to a card" for details on SD cards usable in this unit.

[HDC-TM90]

Built-in memory; 16 GB

Compression:

MPEG-4 AVC/H.264

Recording mode and transfer rate:

[1080/60p]; Approx. 28 Mbps (VBR) (NTSC areas)

[1080/50p]; Approx. 28 Mbps (VBR) (PAL areas)

[HA]; Approx. 17 Mbps (VBR)

[HG]; Approx. 13 Mbps (VBR)

[HX]; Approx. 9 Mbps (VBR)

[HE]; Approx. 5 Mbps (VBR)

[iFrame]; Approx. 28 Mbps (VBR)

Refer to "Recording modes/approximate recordable time" for the recordable time.

Picture size:

[1080/60p]; 1920×1080/60p (NTSC areas)

[HA]/[HG]/[HX]/[HE]; 1920×1080/60i (NTSC areas)

[iFrame]; 960×540/30p (NTSC areas)

[1080/50p]; 1920×1080/50p (PAL areas)

[HA]/[HG]/[HX]/[HE]; 1920×1080/50i (PAL areas)

[iFrame]; 960×540/25p (PAL areas)

Audio compression:

[1080/60p] (NTSC areas), [1080/50p] (PAL areas),

[AVCHD]; Dolby Digital/2 ch (built-in microphone/external microphone)

[iFrame]; AAC/2 ch

■ Still pictures

Recording media:

SD Memory Card (FAT12 and FAT16 system compliant)

SDHC Memory Card (FAT32 system compliant)

SDXC Memory Card (exFAT system compliant)

Refer to "Recording to a card" for details on SD cards usable in this unit.

[HDC-TM90]

Built-in memory; 16 GB

Compression:

JPEG (Design rule for Camera File system, based on Exif 2.2 standard),

DPOF corresponding

Picture size:

Picture aspect [4:3]; 2592×1944/1600×1200/640×480

Picture aspect [3:2]; 2688×1792/1680×1120

Picture aspect [16:9]; 2816×1584/1920×1080

Refer to "Approximate number of recordable pictures" for the number of recordable pictures.

AC adaptor

Information for your safety

Power source:	AC 110 V to 240 V, 50/60 Hz
Power consumption:	12 W
DC output:	DC 5.0 V, 1.6 A

Dimensions:

46 mm (W)×25 mm (H)×75.5 mm (D) [1.8" (W)×1.0" (H)×3.0" (D)]

Mass (Weight):

Approx. 115 g (Approx. 0.25 lbs.)

Specifications may change without prior notice.

Charging and recording time

Charging/Recording time

- Temperature: 25 °C (77 °F)/humidity: 60%RH
- The stated times are when the AC adaptor is used.

NTSC areas				
Battery model number [Voltage/Capacity (minimum)]	Charging time	Recording mode	Maximum continuous recordable time	Actual recordable time
Supplied battery/ VW-VBK180 (optional) [3.6 V/1790 mAh]	2 h 25 min	[1080/60p]	1 h 30 min	45 min
		[HA], [HG], [HX], [HE]	1 h 35 min	50 min
		[iFrame]	1 h 40 min	
VW-VBK360 (optional) [3.6 V/3580 mAh]	4 h 20 min	[1080/60p]	3 h	1 h 35 min
		[HA], [HG], [HX], [HE]	3 h 15 min	1 h 40 min
		[iFrame]	3 h 25 min	1 h 45 min

PAL areas				
Battery model number [Voltage/Capacity (minimum)]	Charging time	Recording mode	Maximum continuously recordable time	Actual recordable time
Supplied battery/ VW-VBK180 (optional) [3.6 V/1790 mAh]	2 h 25 min	[1080/50p]	1 h 35 min	50 min
		[HA],[HG], [HX],[HE]	1 h 40 min	
		[iFrame]	1 h 45 min	55 min
VW-VBK360 (optional) [3.6 V/3580 mAh]	4 h 20 min	[1080/50p]	3 h 10 min	1 h 40 min
		[HA],[HG], [HX],[HE]	3 h 25 min	1 h 45 min
		[iFrame]	3 h 35 min	1 h 50 min

- These times are approximations.
- The indicated charging time is for when the battery has been discharged completely. Charging time and recordable time vary depending on the usage conditions such as high/low temperature.
- Recordable time of 3D recording mode is the same. (During 3D recording mode, 1080/60p (NTSC areas), 1080/50p (PAL areas) and iFrame recording mode can not be used.)

Recording to a card

The unit can record still pictures or motion pictures to an SD card or built-in memory. To record to an SD card, read the following.

This unit (an SDXC compatible device) is compatible with SD Memory Cards, SDHC Memory Cards and SDXC Memory Cards. When using an SDHC memory card/SDXC memory card with other equipment, check the equipment is compatible with these memory cards.

Cards that you can use with this unit

Use SD cards conforming to Class 4 or higher of the SD Speed Class Rating* for motion picture recording.

Card type	Capacity	Motion picture recording	Still picture recording
SD Memory Card	8 MB/16 MB/32 MB	Cannot be used.	Cannot be guaranteed in operation.
	64 MB/128 MB/256 MB	Cannot be guaranteed in operation.	
	512 MB/1 GB/2 GB		
SDHC Memory Card	4 GB/6 GB/8 GB/12 GB/16 GB/24 GB/32 GB	Can be used.	Can be used.
SDXC Memory Card	48 GB/64 GB		

* SD Speed Class Rating is the speed standard regarding continuous writing. Check via the label on the card, etc.

e.g.:



Recording modes/approximate recordable time

- SD cards are only mentioned with their main memory size. The stated times are the approximate recordable times for continuous recording.

Recording mode	Picture size				
	[1080/60p] (NTSC areas) [1080/50p] (PAL areas)	[HA]	[HG]	[HX]	[HE]
	1920×1080	1920×1080	1920×1080	1920×1080	1920×1080
SD card	4 GB	19 min	30 min	40 min	1 h
	16 GB	1 h 20 min	2 h	2 h 40 min	4 h 10 min
[HDC-TM90] [HDC-TM99] Built-in memory	64 GB	5 h 20 min	8 h 30 min	11 h	16 h 50 min
	16 GB	1 h 20 min	2 h	2 h 40 min	4 h 10 min

- A Favors image quality
- B Favors recording time

Recording mode	[iFrame]	
Picture size	960×540	
SD card	4 GB	19 min
	16 GB	1 h 20 min
	64 GB	5 h 20 min
[HDC-TM90] [HDC-TM99] Built-in memory	16 GB	1 h 20 min

- If recording for long periods, prepare batteries for 3 or 4 times the period you wish to record for.
- The default setting is [HG] Mode.
- Recordable time of 3D recording mode is the same. (During 3D recording mode, 1080/60p (NTSC areas), 1080/50p (PAL areas) and iFrame recording mode cannot be used.)
- Maximum continuously recordable time for one scene: 12 hours
- The recording is paused once when the recording time for one scene exceeds 12 hours, and the recording will automatically resume after a few seconds.
- If a recording with a lot of action is recorded, the recording time is reduced.
- The recordable time may be reduced if recording of short scene is repeated.
- Use time in the row of 4 GB in above table as a guideline for the time that can be copied onto one DVD disc (4.7 GB).

Approximate number of recordable pictures

- SD cards are only mentioned with their main memory size. The stated number is the approximate number of recordable pictures.

(When [ASPECT RATIO] is set to [4:3] and [QUALITY] is set to)

Picture size	Picture size		
	4:3	16:9	3:2
SD card	2592×1944	1600×1200	640×480
	4 GB	1400	3900
	16 GB	6000	15900
[HDC-TM90] [HDC-TM99] Built-in memory	64 GB	24000	492000
	16 GB	6000	15900

(When [ASPECT RATIO] is set to [3:2] and [QUALITY] is set to)

Picture size	Picture size	
	4:3	16:9
SD card	2688×1792	1680×1120
	4 GB	1500
	16 GB	6300
[HDC-TM90] [HDC-TM99] Built-in memory	64 GB	25000
	16 GB	6300

(When [ASPECT RATIO] is set to [16:9] and [QUALITY] is set to)

Picture size	Picture size	
	4:3	2:1
SD card	2816×1584	1920×1080
	4 GB	1680
	16 GB	6800
[HDC-TM90] [HDC-TM99] Built-in memory	64 GB	27000
	16 GB	6800

- When [QUALITY] is set to , the numbers of recordable pictures will take more than the above mentioned.
- The number of recordable pictures depends on whether and are used together and on the subject being recorded.
- Maximum number of recordable pictures that can be displayed is 99999. If the number of recordable pictures exceeds 99999, the number will not change when the picture is taken until the number of recordable pictures gets less than 99999.
- The memory capacity indicated on the label of an SD card is the total of the capacity for copyright protection and management and the capacity that can be used on the unit, a PC etc.

5 Location of Controls and Components

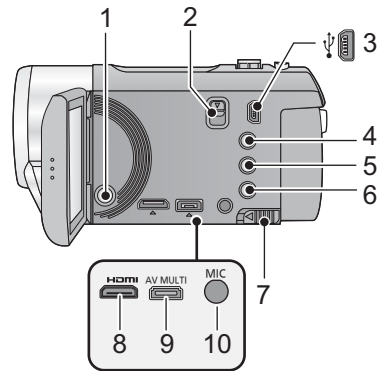

- 1 Power button [⏻/⏻]
- 2 Shoe adaptor release lever [SHOE ADAPTOR RELEASE]
- 3 USB terminal [↗]
- 4 Intelligent auto/Manual button [iA/MANUAL]
- 5 Optical image stabilizer button [(O.I.S.)]
- 6 1080/60p button [1080/60p] (NTSC areas)
1080/50p button [1080/60p] (PAL areas)
- 7 Battery release lever [BATT]
- 8 HDMI mini connector [HDMI]
- 9 AV multi connector [AV MULTI]

- Use the AV multi cable (only the supplied cable).

10 Microphone terminal [MIC]

- A compatible plug-in powered microphone can be used as an external microphone.
- Audio will be stereo (2 ch) with the external microphone input.
- [] (Microphone input level meter) is displayed when the external microphone is connected.
- When the unit is connected with the AC adaptor, sometimes noise may be heard depending on the microphone type. In this case, please switch to the battery for the power supply and the noise will stop.

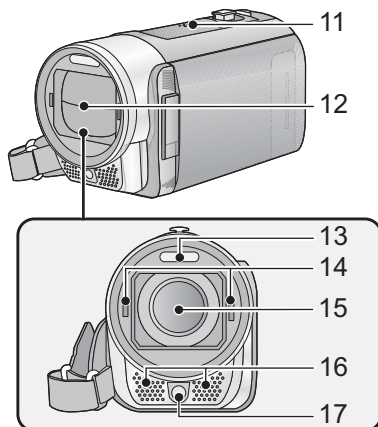

11 Speaker

12 Lens cover

- The lens cover opens in [] Motion Picture Recording Mode or [] Still Picture Recording Mode.

13 Built-in flash

14 Step up ring attachment part (concave)

15 Lens

16 Internal stereo microphones

17 Video light

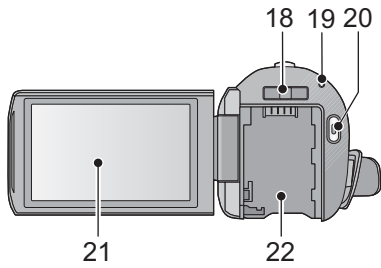

- 18 Shoe adaptor mount [SHOE ADAPTOR]
- 19 Status indicator
- 20 Recording start/stop button
- 21 LCD monitor (Touch screen)

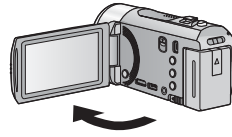

- It can open up to 90°.

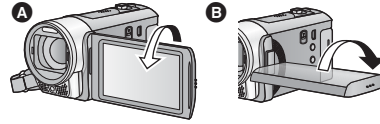

- It can rotate up to 180° **A** towards the lens or 90° **B** towards the opposite direction.

Due to limitations in LCD production technology, there may be some tiny bright or dark spots on the LCD monitor screen. However, this is not a malfunction and does not affect the recorded picture.

22 Battery holder

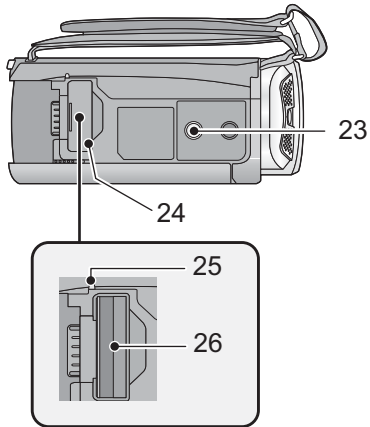

- 23 Tripod receptacle
- If you attach a tripod with a 5.5 mm (0.22 ") screw or larger, it may damage this unit.
- 24 SD card cover
- 25 Access lamp [ACCESS]
- 26 Card slot

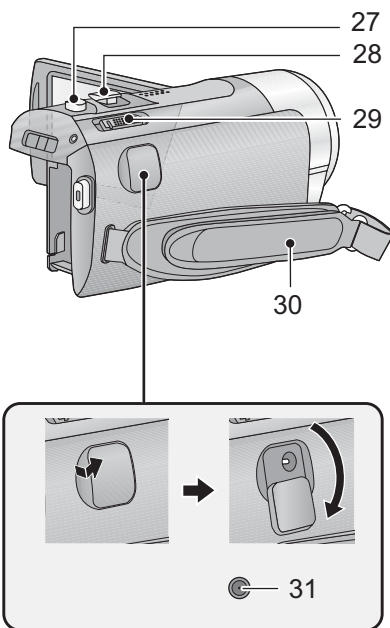

- 27 Photoshot button []
- 28 Zoom lever [W/T] (In Motion Picture Recording Mode or Still Picture Recording Mode)
- Thumbnail display switch [/ Q]
- Volume lever [-VOL+] (In Playback Mode)
- 29 Mode switch
- 30 Grip belt
- Adjust the length of the grip belt so that it fits your hand.

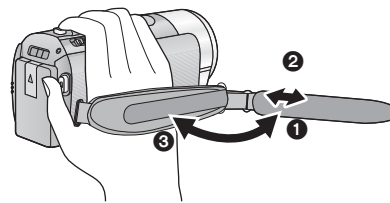





- 1 Flip the belt.
- 2 Adjust the length.
- 3 Replace the belt.
- 31 DC input terminal [DC IN]
- Do not use any other AC adaptors except the supplied one.

Selecting a mode

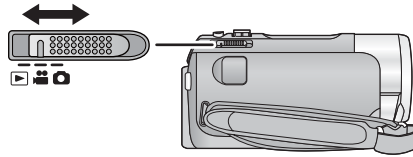
Slide the mode switch to switch between recording and playback.

Operate the mode switch to change the mode to ,  or .



	Motion Picture Recording Mode
	Still Picture Recording Mode
	Playback Mode

How to use the touch screen

You can operate by directly touching the LCD monitor (touch screen) with your finger.

It is easier to use the stylus pen (supplied) for detailed operation or if it is hard to operate with your fingers.

■ Touch

Touch and release the touch screen to select icon or picture.

- Touch the center of the icon.
- Touching the touch screen will not operate while you are touching another part of the touch screen.

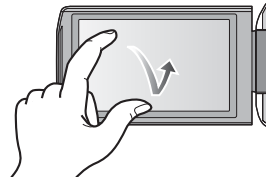

■ Slide while touching

Move your finger while pressing on the touch screen.

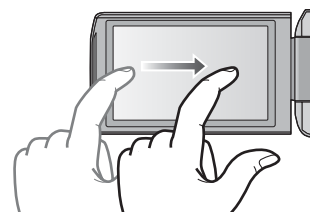

■ About the operation icons

    :

These icons are used to switch the menu and thumbnail display page, for item selection and setting etc.

 :

Touch to return to the previous screen such as when setting menus.



About the Touch Menu

Touch ◀ (left side)/▶ (right side) of  on the Touch Menu to switch the operation icons.

Touch ◀ (left side)/▶ (right side) of on the Touch Menu.

- It is also possible to switch the operation icons by sliding the Touch Menu right or left while touching it.

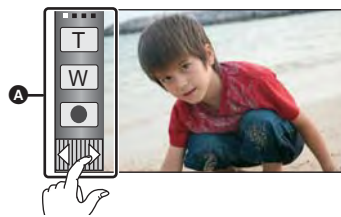

A Touch Menu

Recording Mode

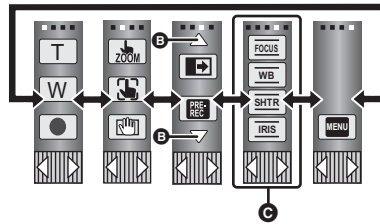

Playback Mode

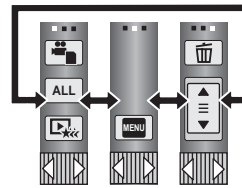

B Touch these icons to switch pages upward or downward.

C Displayed only during the Manual Mode.

■ To display the Touch Menu



The Touch Menu will disappear when no function is performed for a specific period of time during Recording Mode. To display it again, touch .

- Do not touch on the LCD monitor with hard pointed tips, such as ball point pens.
- Perform the touch screen calibration when the touch is not recognized or wrong location is recognized.

6 Service Mode

1. Indication method of the service menu

Set the mode switch "Motion Picture Recording" mode.

2. While the power is turned OFF, keep pressing the "Power" button, "Zoom lever" to W side and "intelligent auto/Manual" button for more than 3 seconds until the top screen of the Service Mode Menu being displayed.

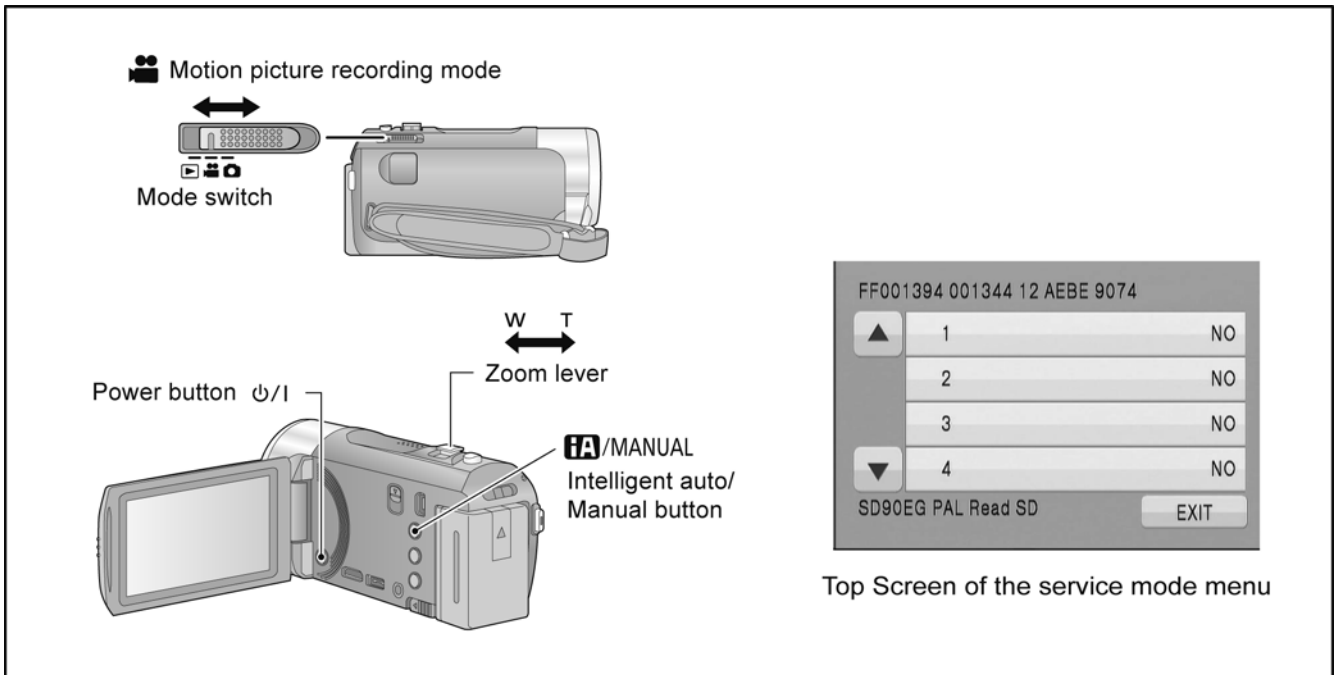

Service mode menu

Screen display	Contents	Function
1	Factory settings	Function to throw a product up in a factory shipment state (When recorded data in Built-in memory, "error display" is done)
3	Built-in memory self check execution (HDC-TM90/TM99 only)	Function to check self as for the state of Built-in memory
4	Lock search history indication	Display the camera system error cord for three histories saved in EEPROM
5	Power ON self check result display	Power ON self check (function to diagnose correct function of the device and interface between devices) result display
9	Forced full flash emission	Forced full flash emission for discharging the capacitor on FLASH P.C.B. and set to prohibit charge
10	Erasing the lock histories	Erasing the error histories (working time is not erased)
11	Erasing the internal media management information	Erasing the internal media management information for fast boot stored in IC3402(flash memory)
12	Camera data indications while the video playback	Display the camera informations (Shutter speed, Iris value, White balance and focal length) while playing recorded video

NOTE:

Do not using service mode except above table of Service mode menu.

3. End method of the top screen of the service mode menu

Touch the [EXIT] of LCD to end the service mode, and then POWER OFF.

6.1. Built-in Memory Self Check Execution (HDC-TM90/TM99 only)

Touch the [3] of LCD, select Built-in memory self check execution.

Operation specifications

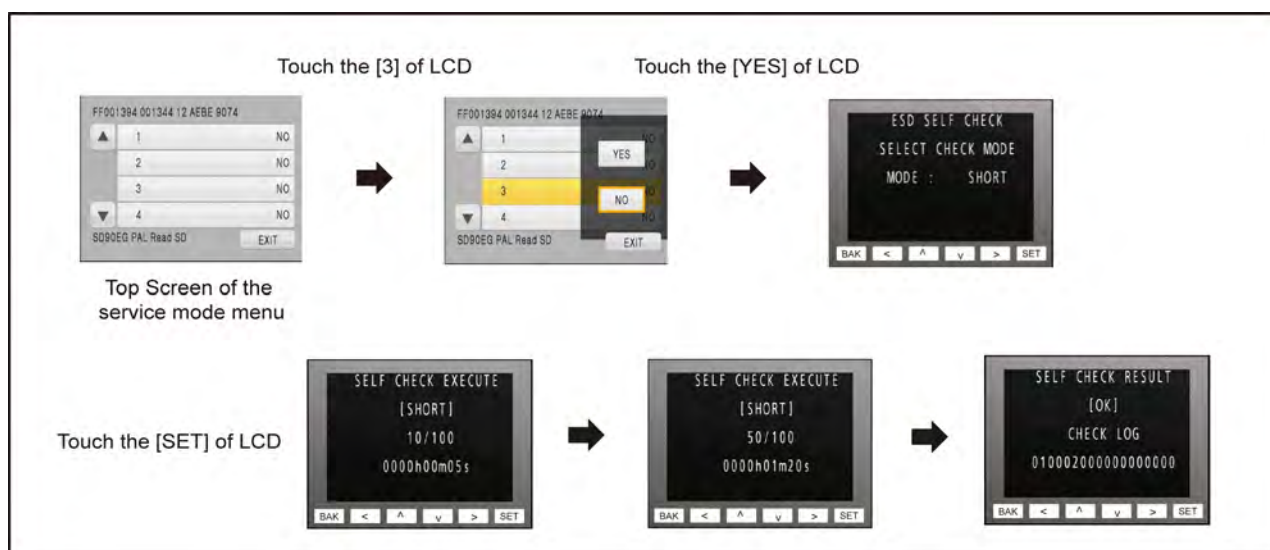

Indication contents

- Built-in memory self check result display
Display the Built-in memory self check execution.
Displays other than "OK" are abnormalities of Built-in memory.
Touch the [BAK] of LCD to end the service mode, and then POWER OFF.

6.2. Lock Search History Indication

Touch the [4] of LCD, select Lock search history indication.

Operation specifications

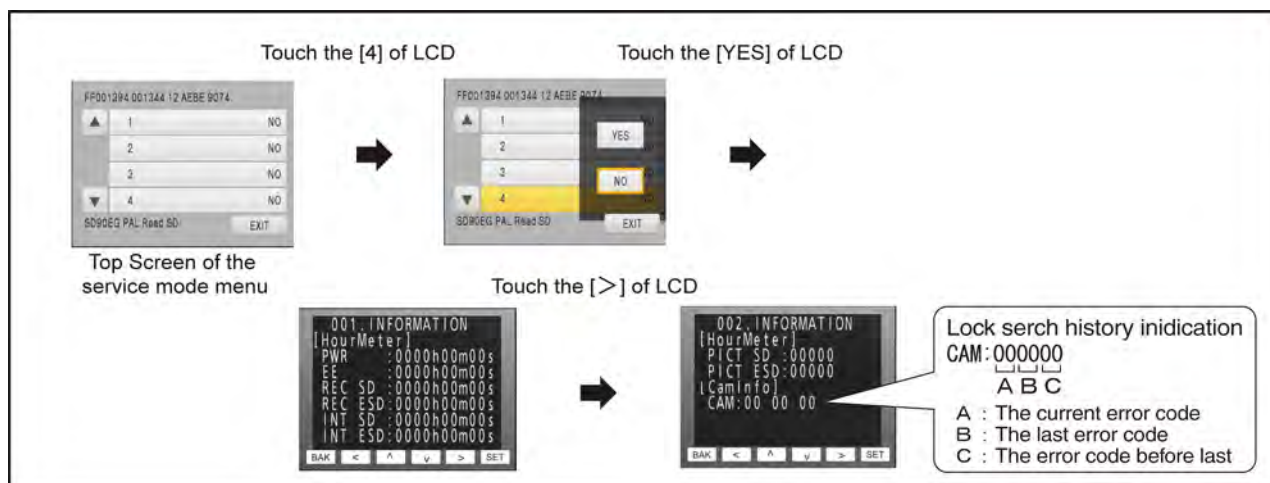

Indication contents

- Lock search history indication
Display the camera system error cord for three histories saved in EEPROM.
- The error cord contents which are displayed

Error code	Function
51	Focus control is abnormal
52	Zoom control is abnormal
53	OIS lens control is abnormal
54	Zoom control is abnormal (2)
71	Lens cover open/close is abnormal
73	High temperature is abnormal
33	Communication between IC2006 to IC3401 is abnormal

Cutting of battery connection or AC power supply connection to end the service mode.

6.3. Power ON Self Check Result Display

Touch the [5] of LCD, select Power ON self check result display.

Operation specifications

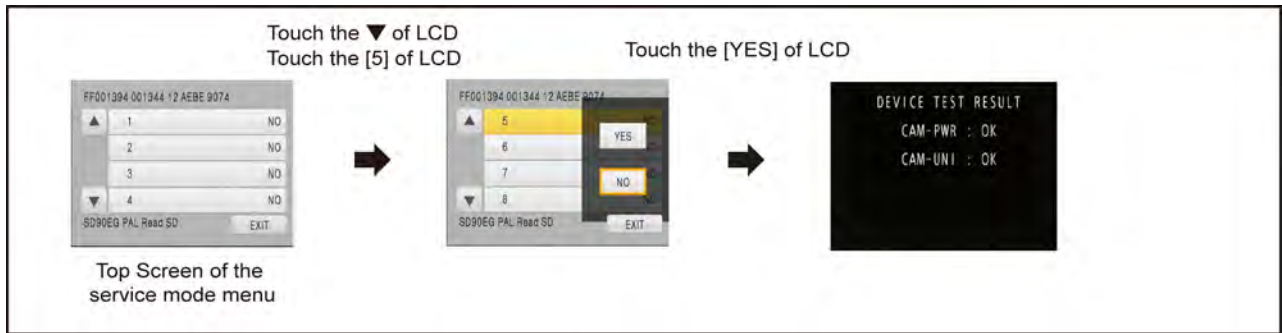

Indication contents

- Power ON self check result display
Function to diagnose correct function of the device and interface between devices result display.

Display the following communication test result.

- CAM-PWR : Communication test between IC2006 to IC1503
- CAM-UNI : Communication test between IC2006 to IC3401

Display other than "OK" are abnormalities of each lines.

Cutting of battery connection or AC power supply connection to end the service mode.

6.4. Forced full flash emission

Touch the [9] of LCD, select Forced full flash execution.

Operation specifications

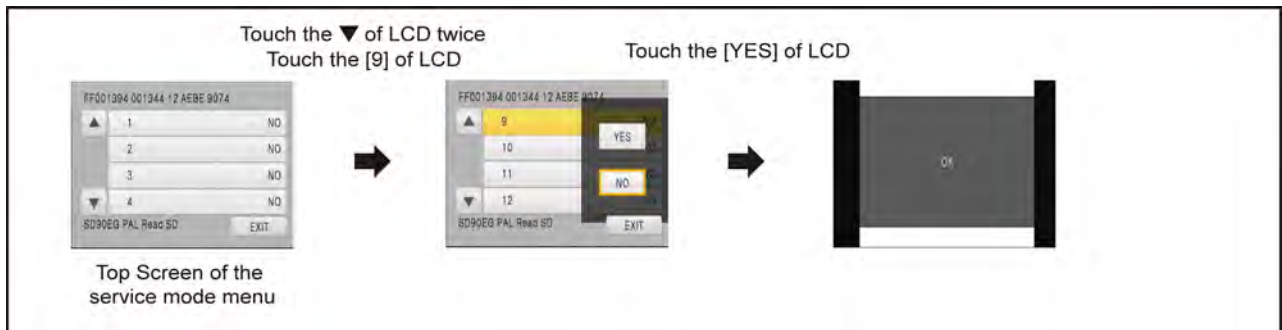

Indication contents

- Discharging the capacitor without using register.
Forced full flash emission for charge capacitor completely discharge.
To prevent electric shock, we recommend enforcement before disassembling.

Press the power button and turn off.

6.5. Erasing the lock histories

Touch the [10] of LCD, select erasing the lock histories execution.

Operation specifications

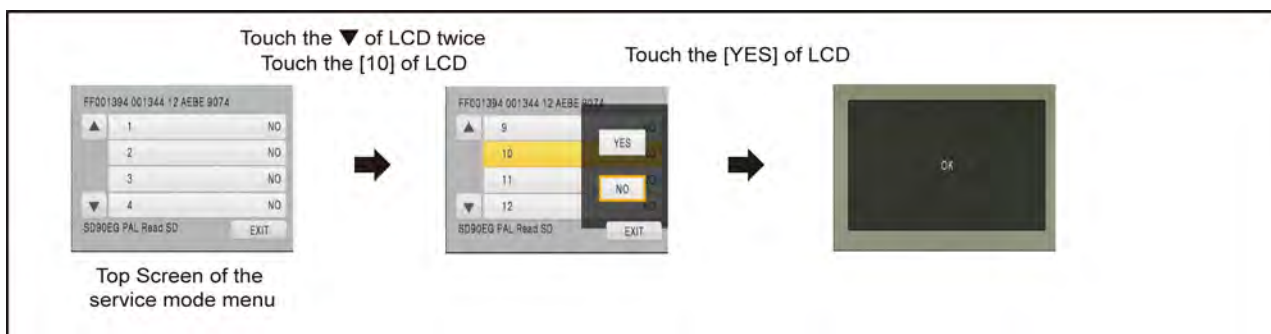

Indication contents

- Erasing the error histories stored in EEPROM. (working time is not erased)

Press the power button and turn off.

6.6. Erasing the internal media management information (HDC-TM90/TM99 only)

Touch the [11] of LCD, select erasing the internal media management information for fast boot stored in flash memory.

Operation specifications

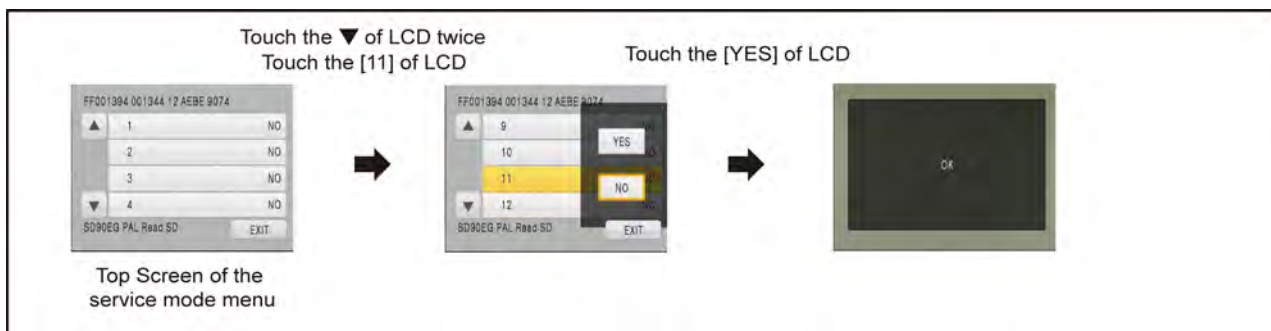

Indication contents

- The fast boot management informations of the internal media are stored in the flash memory. The following cases, be sure to implement for protection of customer's recorded data. However, if there is no problem to delete customer's recorded data, erasing the internal media management information is not required.
- Case1:
When replacing the flash memory chip (IC3402) or replacing the MAIN P.C.B. Unit.
Before checking the operations after replacing the parts, erasing the internal media management information.
- Case2:
When replacing the ESD P.C.B. Unit.
Before replacing the ESD P.C.B. Unit, erasing the internal media management information. then replace it new one.

CAUTION:

When turning the unit on after performing the above operation, the internal media management information is stored into the unit, the playback of the recorded data is normally.

When not performing the above operation, the customer's recorded data will disappear.

Press the power button and turn off.

6.7. Camera data indications while the video playback

Touch the [12] of LCD, select indicating the camera informations while playing back the recorded video.

Operation specifications

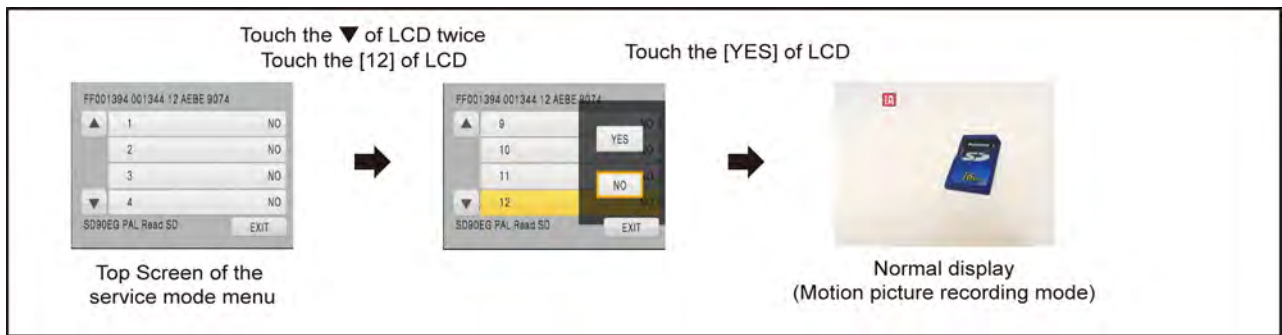

Indication contents

- While playing back the recorded videos, the camera informations (Shutter speed, Iris value, White balance and focal length) are superimposed on the LCD screen.



Press the power button and turn off.

7 Service Fixture & Tools

7.1. When Replacing the Main P.C.B.

After replacing the MAIN P.C.B., be sure to achieve adjustment.

The adjustment instruction is available at "software download" on the "Support Information from NWBG/VDBG-AVC" web-site in "TSN system", together with Maintenance software.

7.2. Service Position

This Service Position is used for checking and replacing parts. Use the following Extension cables for servicing.

Table S1 Extension Cable List

No.	Parts No.	Connection	Form
1	RFKZ0448	FP6001(MAIN) - MONITOR FPC	33PIN 0.3 FFC
2	RFKZ0444	PP6001(MAIN) - PS6401(SD HOLDER)	50PIN 0.5 B to B
3	VFK1480	FP6003(MAIN) - ECM HOLL FPC(FRONT CASE UNIT)	6PIN 0.5 FFC
4	VFK1388	FP6004(MAIN) - FP7001(FLASH)	12PIN 0.5 FFC
5	VFK1441	FP6005(MAIN) - LENS BARRIER UNIT	8PIN 0.5 FFC
6	VFK1440	FP6402(SD HOLDER) - OPERATION SW UNIT(TOP CASE UNIT)	10PIN 0.5 FFC

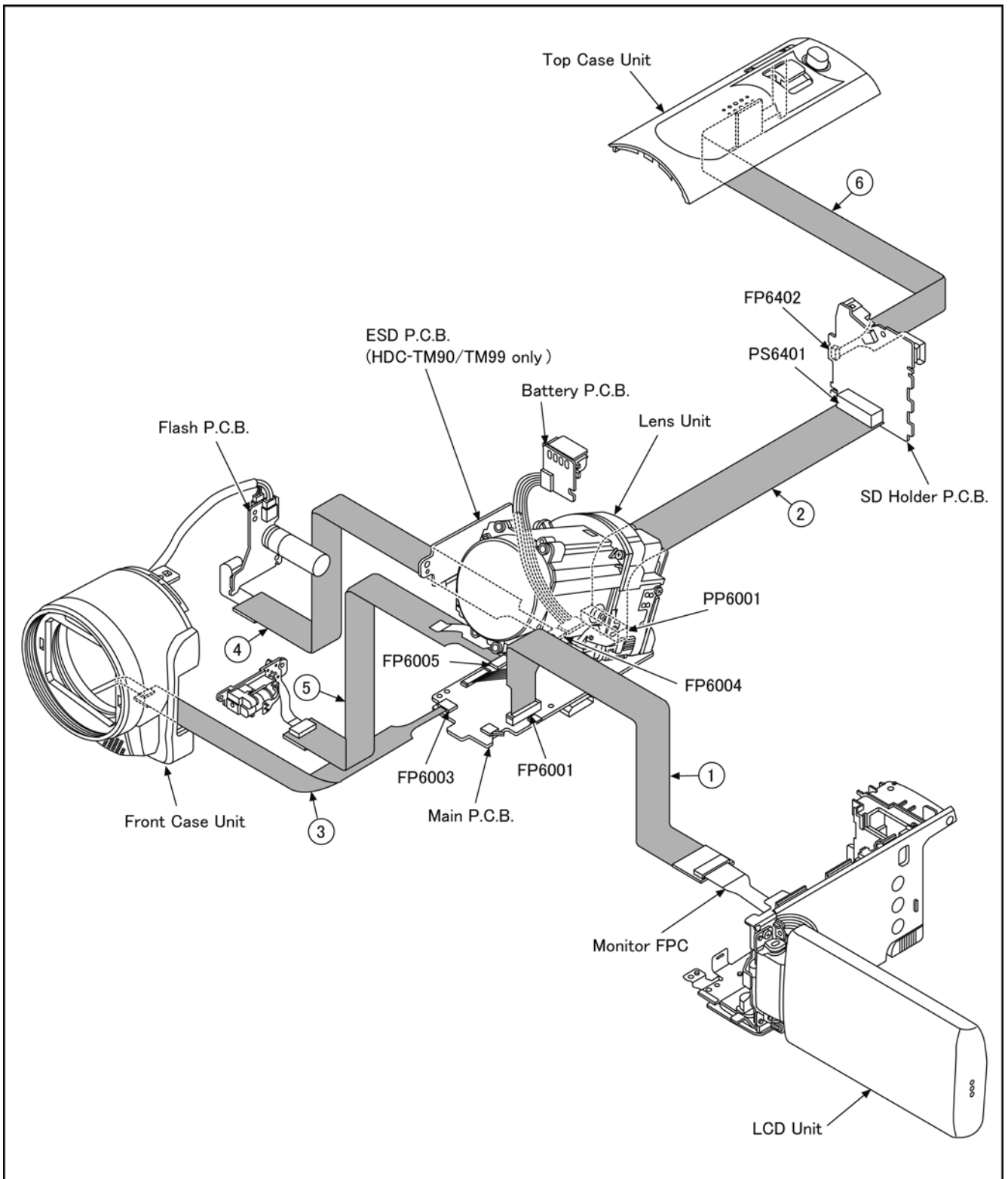

CAUTION-1. (When servicing FLASH P.C.B.)

1. Be sure to discharge the capacitor on FLASH P.C.B.
 Refer to "HOW TO DISCHARGE THE CAPACITOR ON FLASH P.C.B."
 The capacitor voltage is not lowered soon even if the AC Cord is unplugged or the battery is removed.
2. Be careful of the high voltage circuit on FLASH P.C.B..
3. DO NOT allow other parts to touch the high voltage circuit on FLASH P.C.B..

8 Disassembly and Assembly Instructions

8.1. Disassembly Flow Chart for the Unit

This is a disassembling chart.

When assembling, perform this chart conversely.

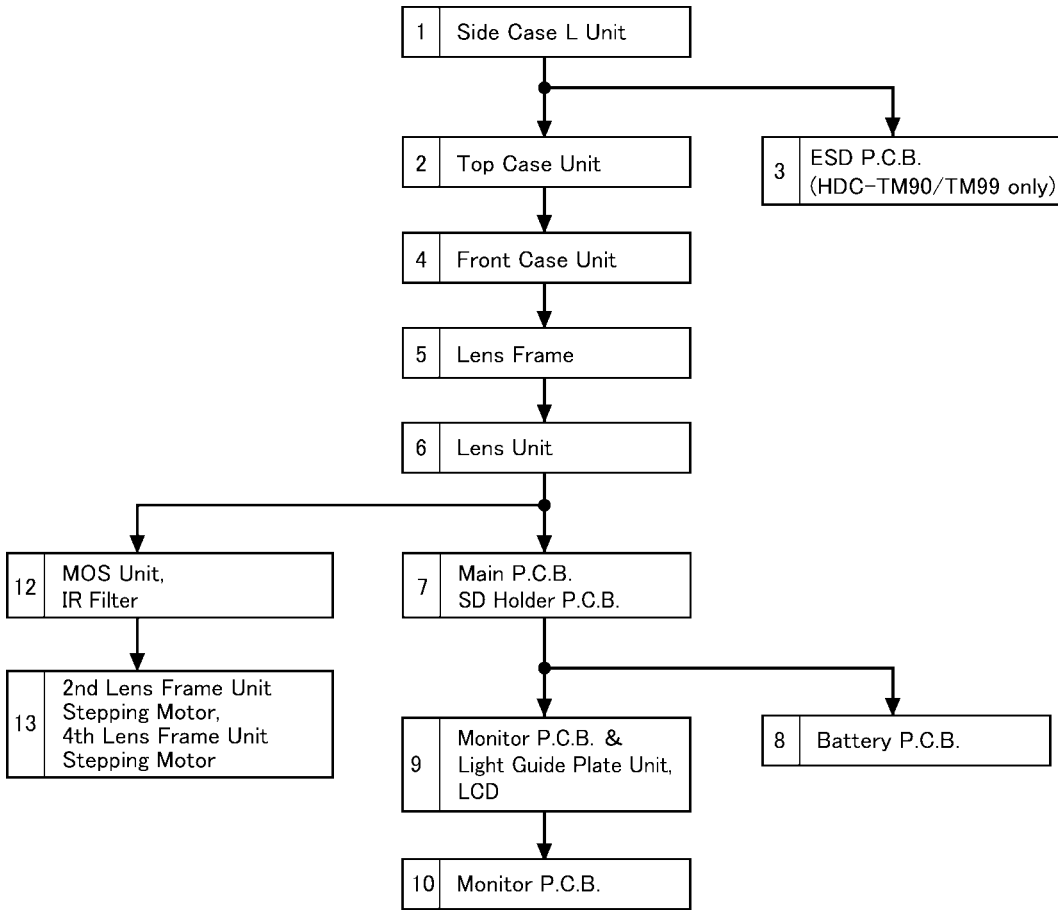

8.2. PCB Location

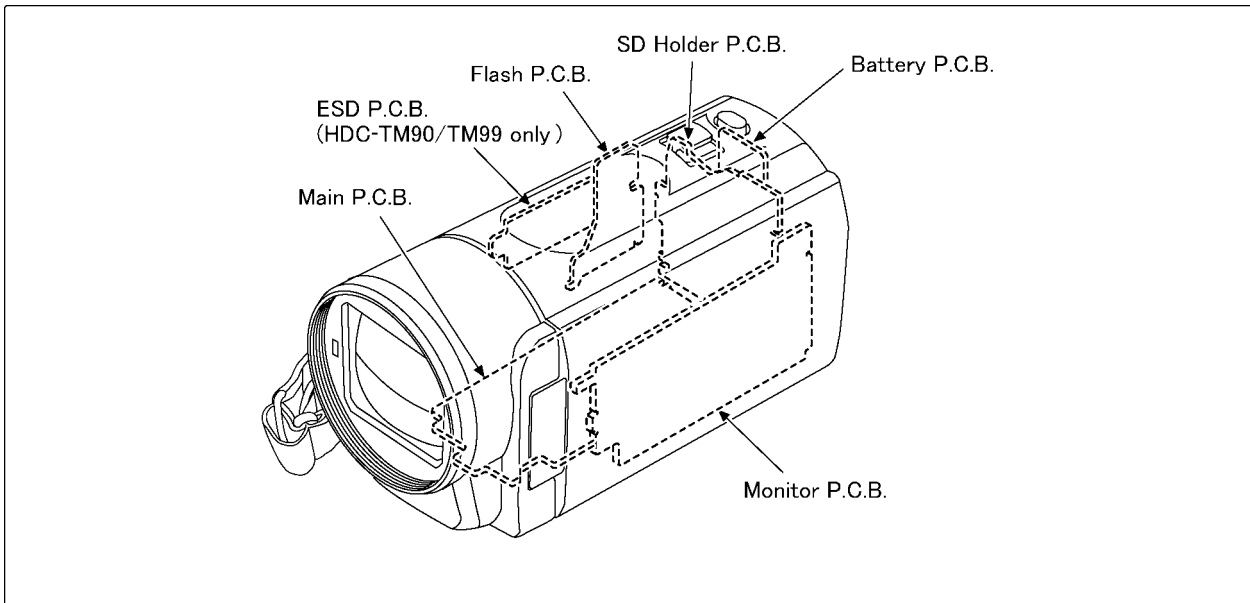

8.3. Disassembly Procedure for the Unit

No.	Item	Fig	Removal
1	Side Case-L Unit	Fig. D1	2 Screws (A)
			1 Screws (B)
			2 Screws (C)
		Fig. D2	3 Screws (D)
			1 Locking tab 4 Hanging parts P6005 (Connector) Side Case-L Unit
2	Top Case Unit	Fig. D3	1 Screw (E)
			1 Screw (F)
			5 Locking tabs
			FP6402 (Flex)
			P6401 (Connector)
			Top Case Unit
3	ESD P.C.B. (HDC-TM90/TM99 only)	Fig. D4	2 Screws (G)
			FP3201 (Flex)
			ESD P.C.B.
4	Front Case Unit	Fig. D5	1 Screw (H)
			2 Screws (I)
		Fig. D6	P7001(Connector)
			P7002 (Connector)
			2 Locking tabs 1 Rib
		Fig. D7	FP6003 (Flex)
			Front Case Unit
5	Lens Frame Unit	Fig. D8	4 Screws (J)
			2 Locking tabs
			FP6004 (Flex)
		Fig. D9	FP6005 (Flex)
			Lens Frame Unit
6	Lens Unit	Fig. D10	FP6008 (Flex)
			P6001 (Connector)
			Lens Unit
		Fig. D11	NOTE: (When Installing)
7	Main P.C.B. SD Holder P.C.B.	Fig. D12	1 Screw (K)
			Battery Frame
		Fig. D13	2 Screws (L)
			FP6001 (Flex)
			P6003 (Connector) SD Holder P.C.B. Main P.C.B.
Fig. D14	NOTE: (When Installing)		
8	Battery P.C.B.	Fig. D15	Battery P.C.B.
9	Monitor P.C.B. & Light Guide Plate Unit LCD Unit	Fig. D16	2 Screws (N)
			Fig. D17
		LCD Case (T) Unit	
		2 Screws (O)	
		3 Ribs	
		LCD Frame	
		Fig. D18	FP901 (Flex)
			FP904 (Flex)
			FP905 (Flex)
			3 Locking tabs
Monitor P.C.B. & Light Guide Plate Unit			
LCD Unit			

No.	Item	Fig	Removal
10	Monitor P.C.B.	Fig. D19	1 Locking tab
			1 Hanging part
			Reflection Sheet
			Light Guide Plate
			Diffusion Sheet
			Prism Sheet B
			Prism Sheet A
			LCD Holder
11	MOS Unit IR Filter	Fig. D20	3 Screws (P)
			MOS Cushion
			MOS Unit
			IR Filter
12	2nd Lens Frame Stepping Motor 4th Lens Frame Stepping Motor	Fig. D21	3 Screws (Q)
			Solder (4 points)
			2 Projection Part
		Fig. D22	2nd Lens Frame Stepping Motor
			2 Screws (R)
			Solder (6 points)
			2 Projection Part 4th Lens Frame Stepping Motor

NOTE:

Before servicing, execute the item of "6.4. Forced full flash emission".

When servicing and reassembling, remove the card and battery pack from the unit.

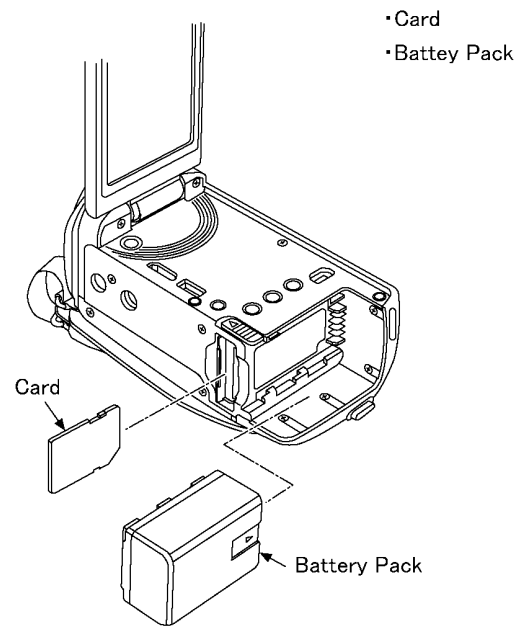

8.3.1. Removal of the Side Case-L Unit

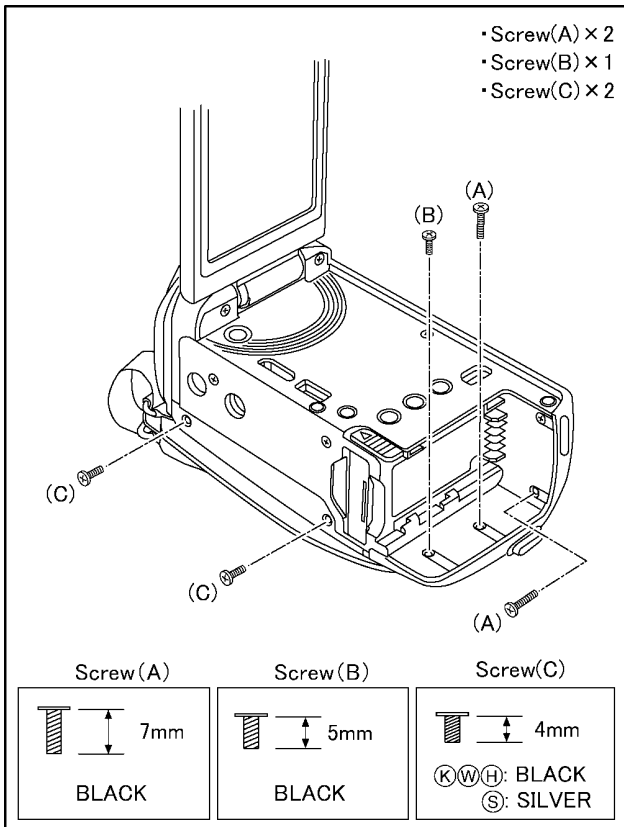

Fig. D1

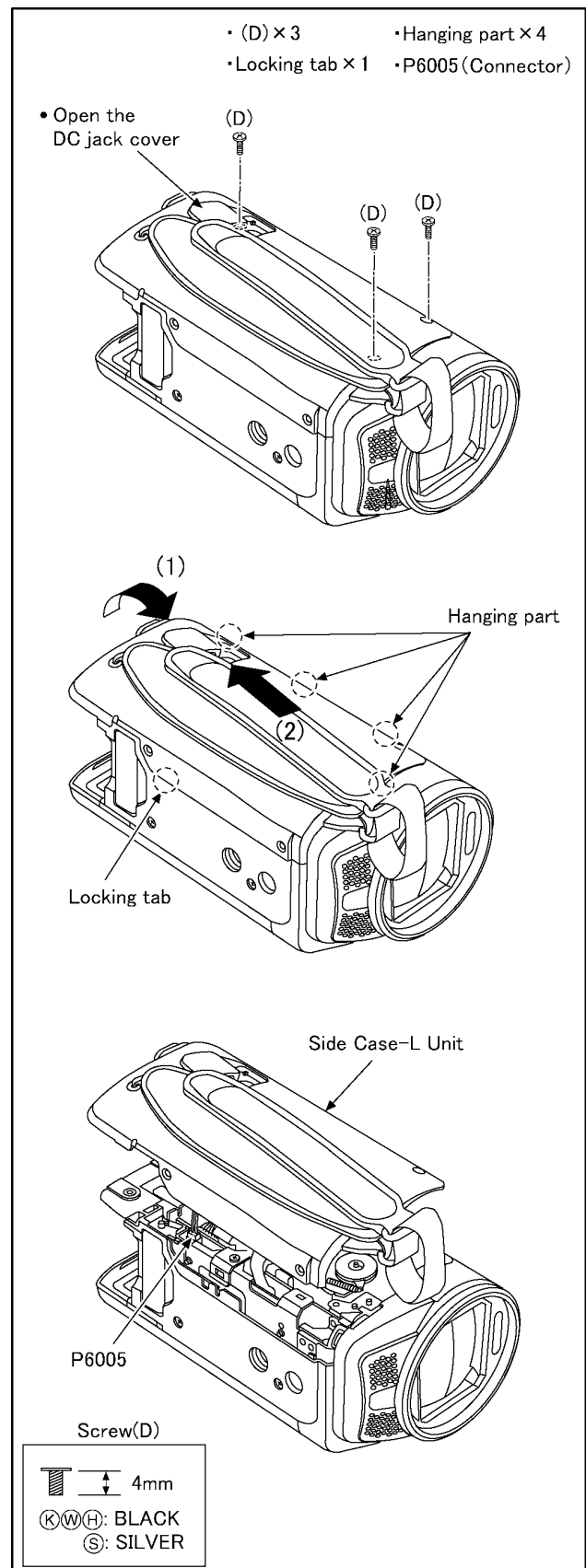

Fig. D2

8.3.2. Removal of the Top Case Unit

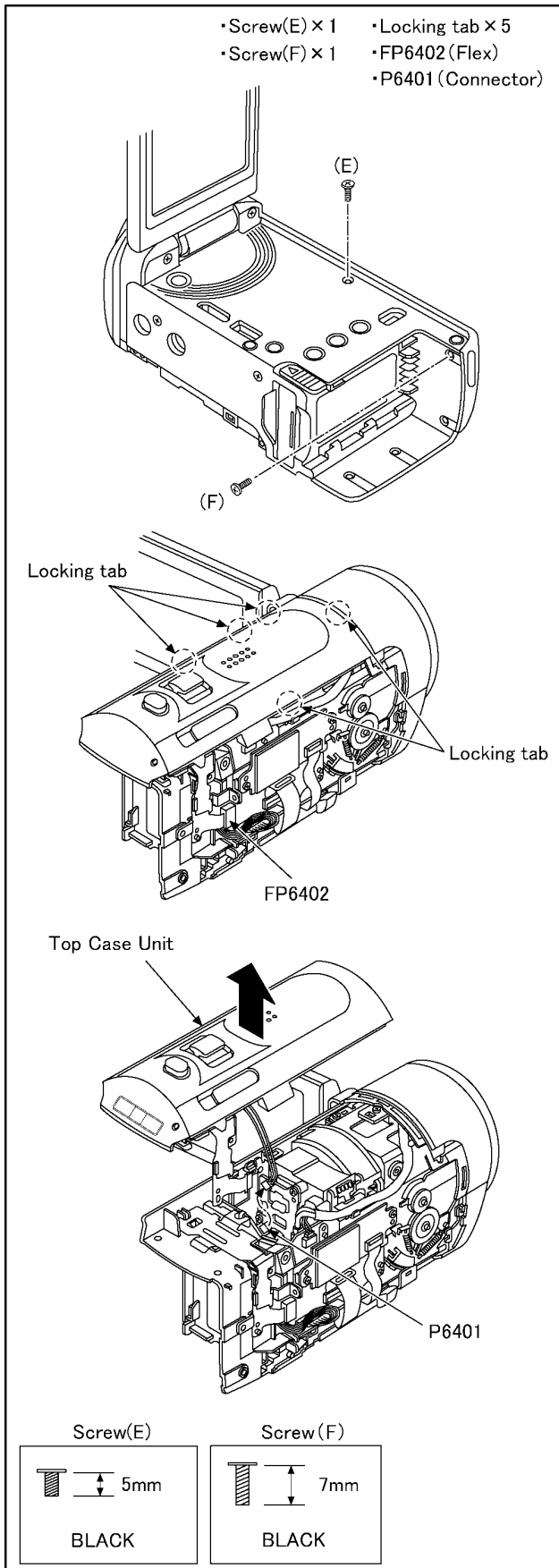
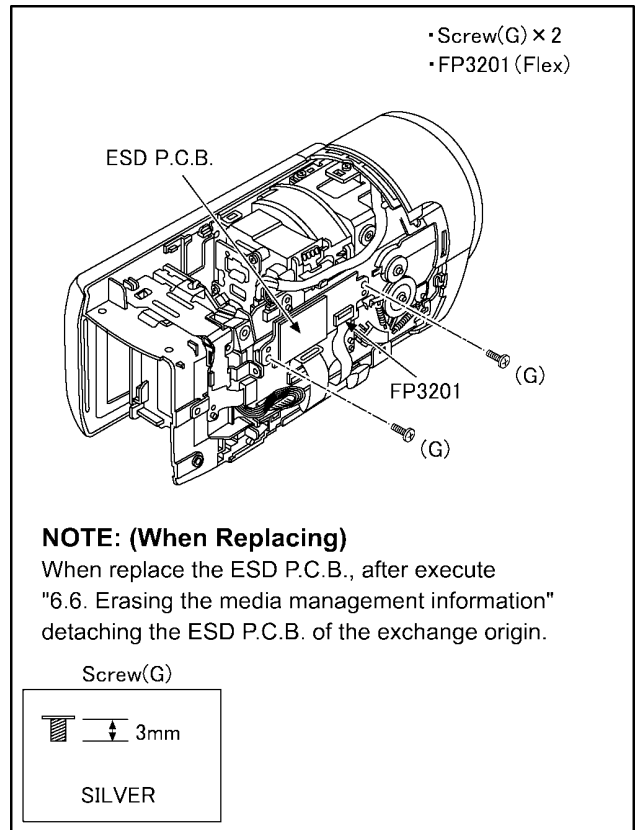

Fig. D3

8.3.3. Removal of the ESD P.C.B. Unit (HDC-TM90/TM99 only)



NOTE: (When Replacing)

When replace the ESD P.C.B., after execute "6.6. Erasing the media management information" detaching the ESD P.C.B. of the exchange origin.

Fig. D4

8.3.4. Removal of the Front Case Unit

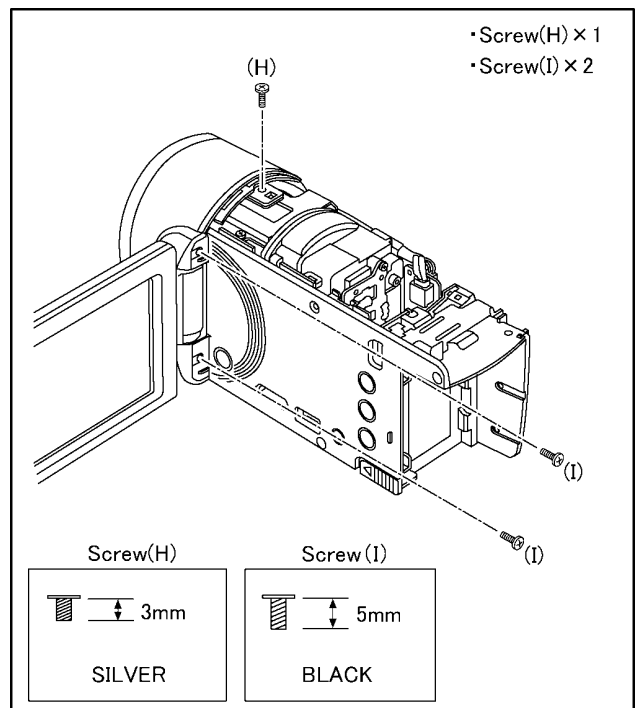

Fig. D5

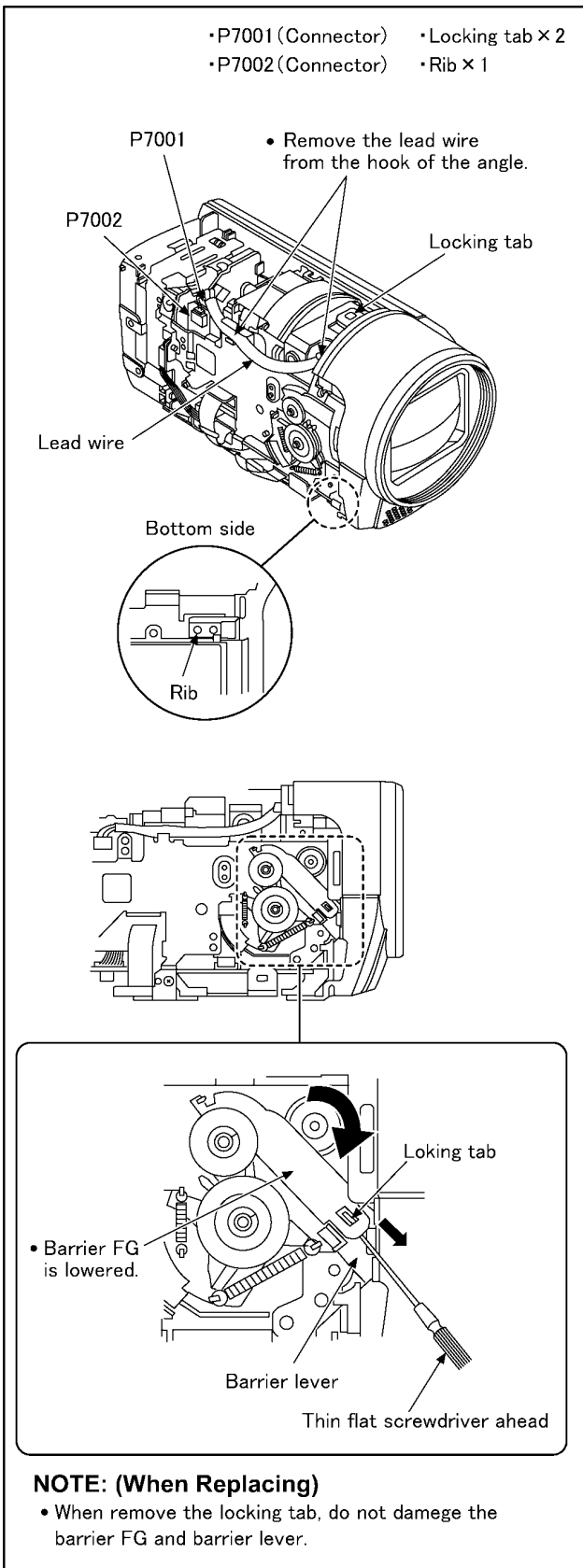

Fig. D6

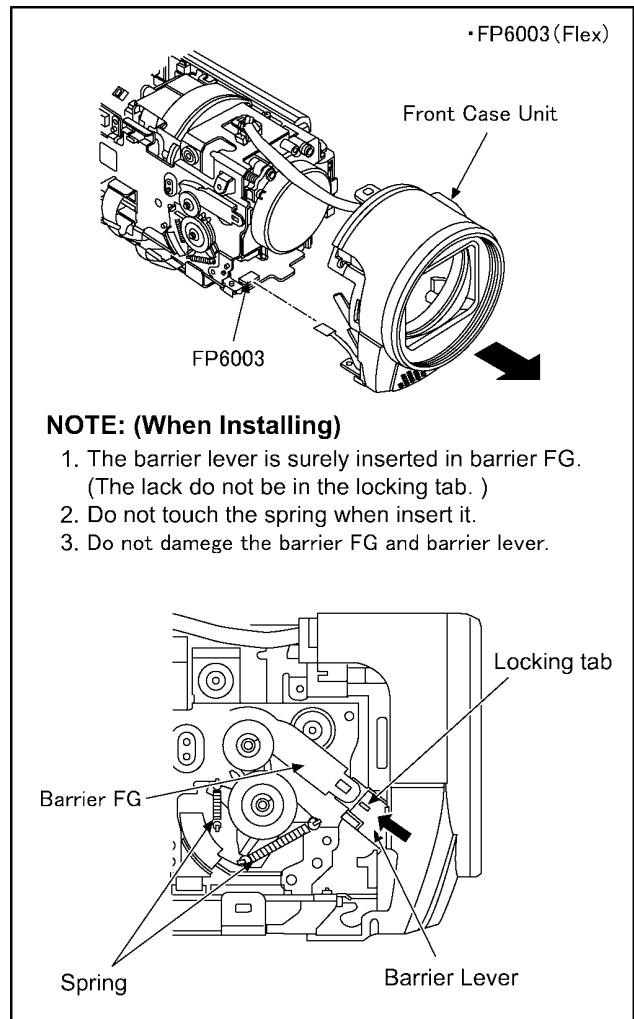

Fig. D7

8.3.5. Removal of the Lens Frame Unit

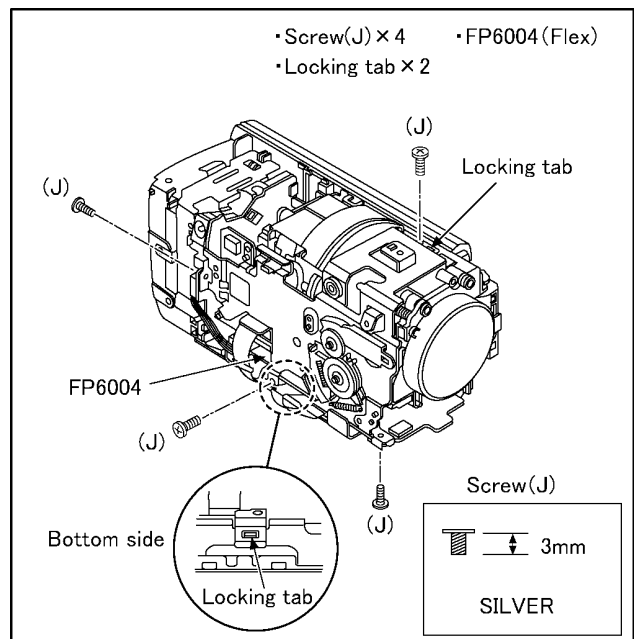

Fig. D8

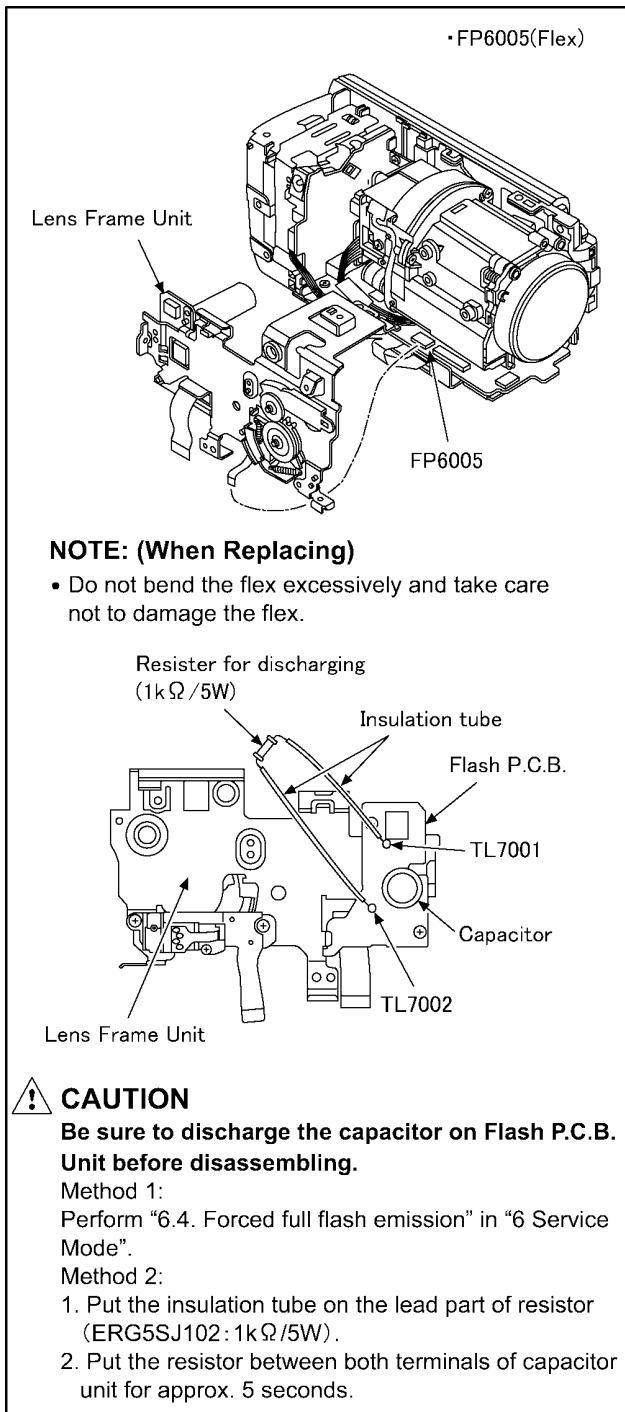

Fig. D9

8.3.6. Removal of the Lens Unit

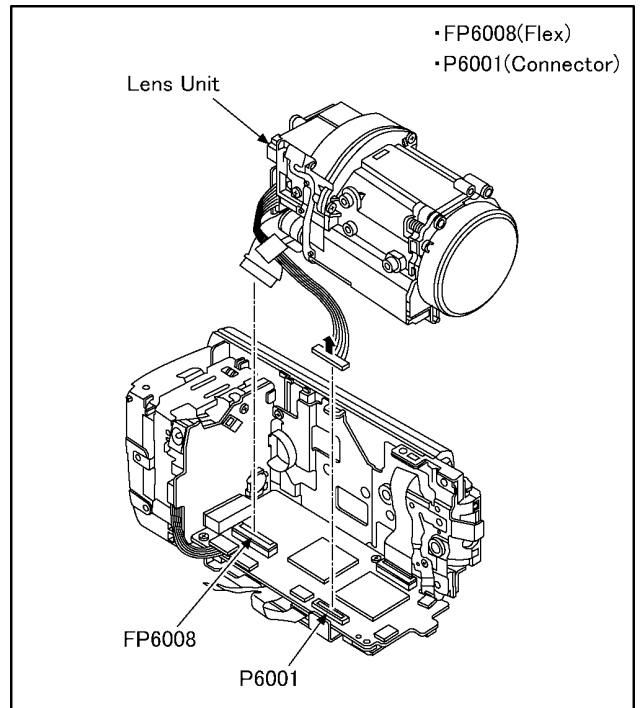
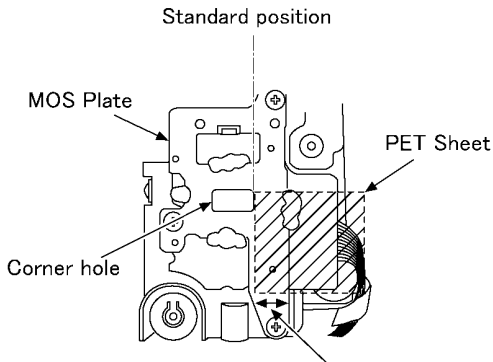

Fig. D10

NOTE: (When Installing)

- When install the lens unit, after putting the PET sheet according to the following procedures.

1. Put on the PET sheet to MOS plate along the corner hole.



- Put on the PET sheet in the width of the plate

2. After a coaxial line is processed below, and then fixes in the PET sheet.
(Do not add the stress to solder part, the MR adjustment screw, and the zoom motor cap.)

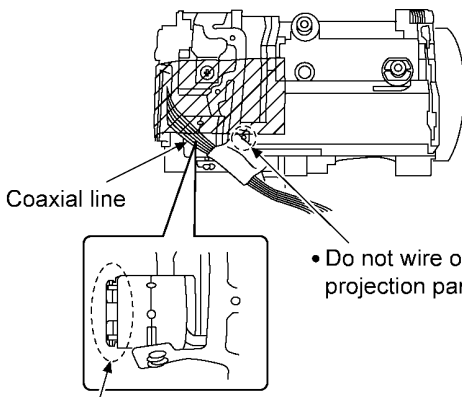

Zoom Motor Cap

3. When put the PET sheet, do not pull it strongly, and sticks it from the MOS plate side to the lens side part.
(To suffer stress to the MOS P.C.B..)

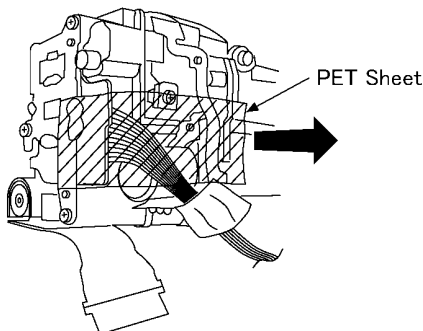

Fig. D11

8.3.7. Removal of the Main P.C.B. and SD Holder P.C.B.

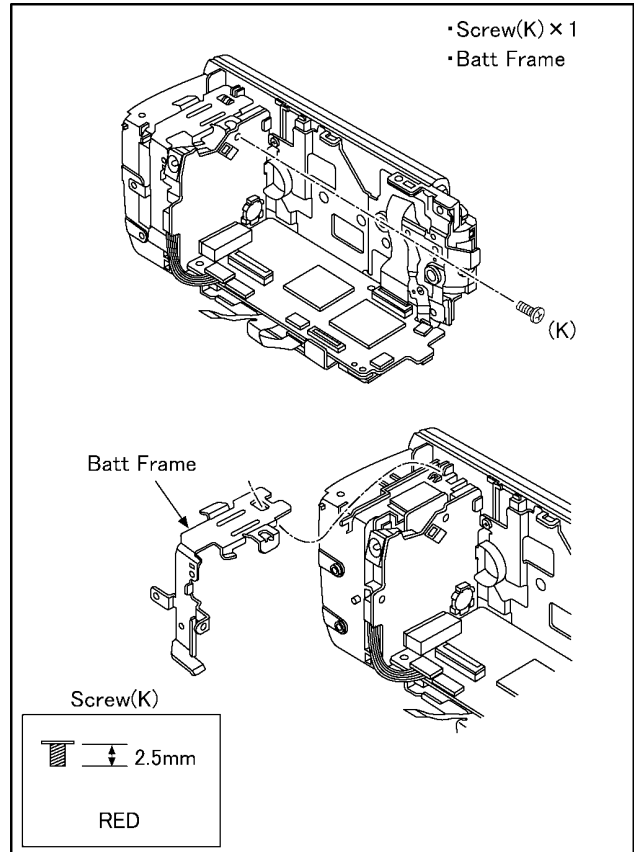

Fig. D12

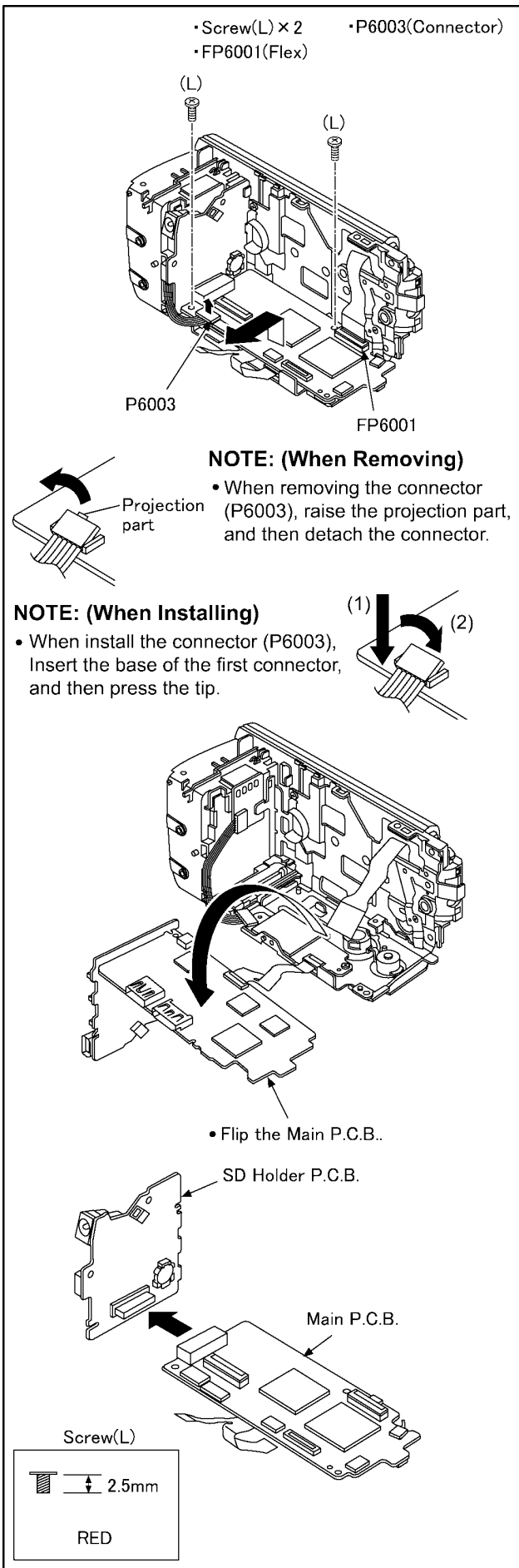

Fig. D13

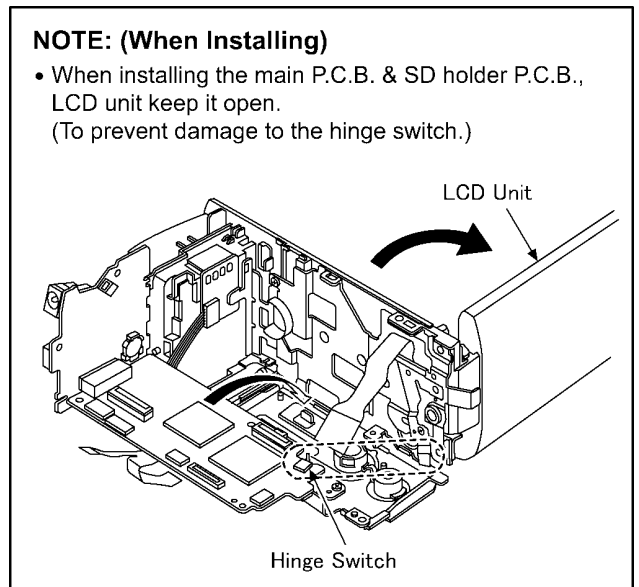

Fig. D14

8.3.8. Removal of the Battery P.C.B.

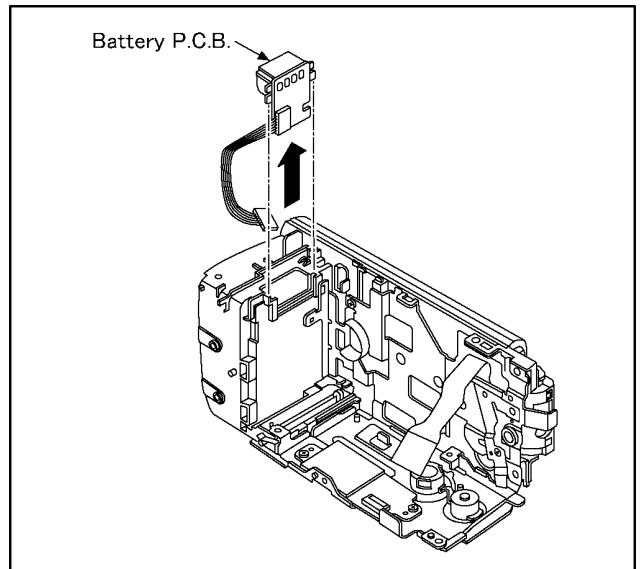

Fig. D15

8.3.9. Removal of the Monitor P.C.B. & Light Guide Plate Unit and LCD Unit

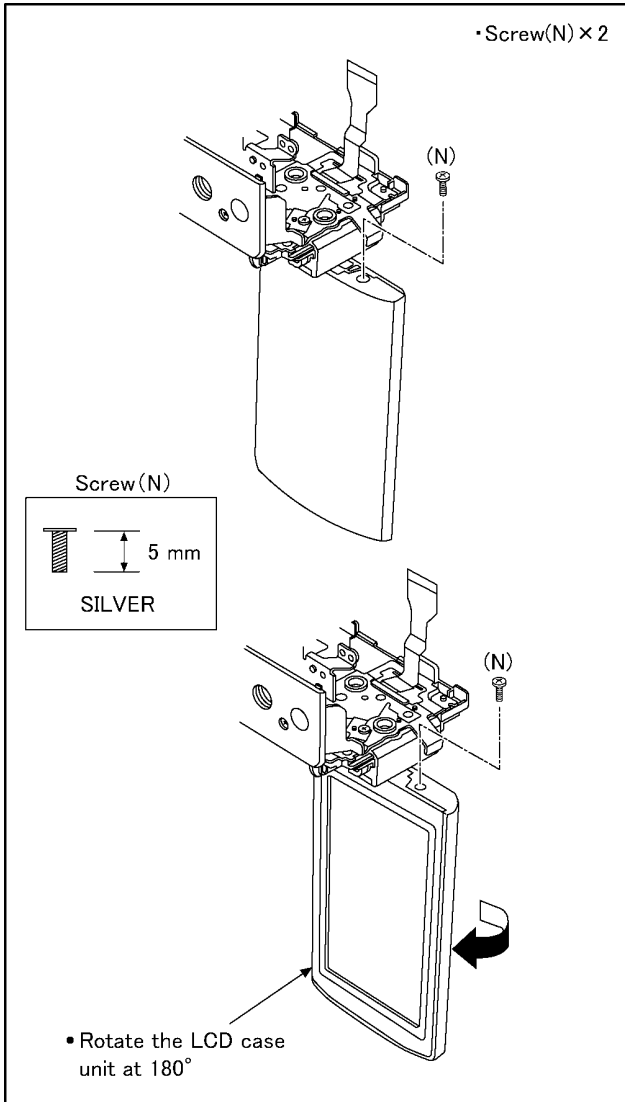

Fig. D16

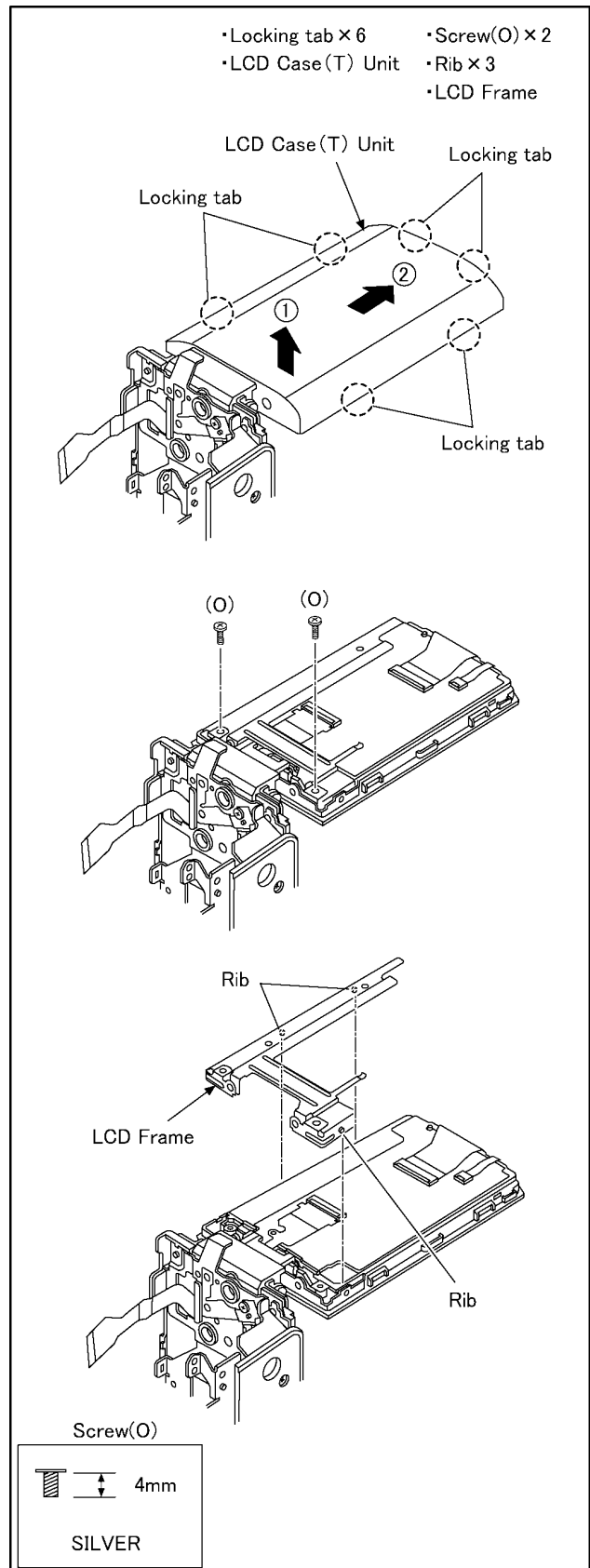

Fig. D17

8.3.11. Removal of the MOS Unit and IR Filter

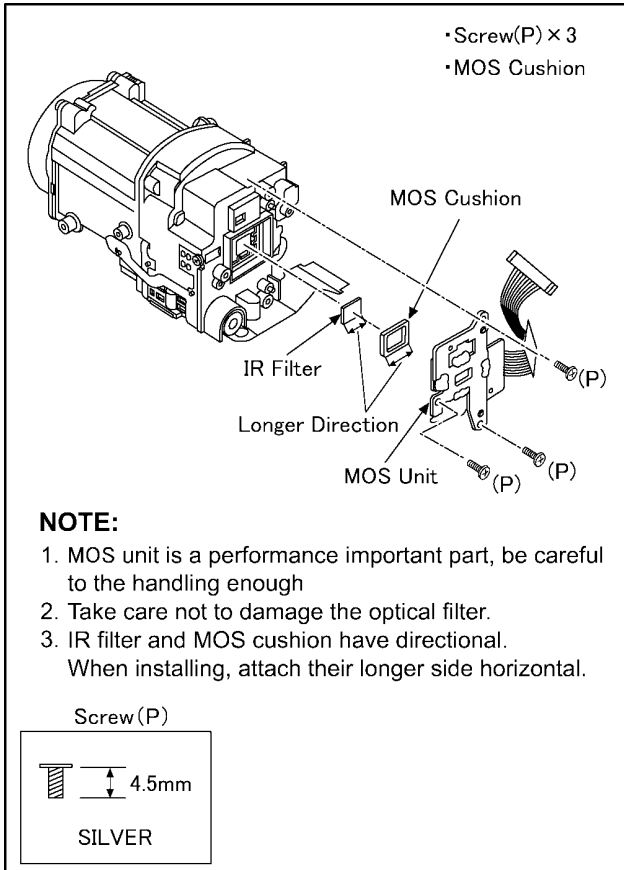

Fig. D20

8.3.12. Removal of the 2nd Lens Frame Stepping Motor and 4th Lens Frame Stepping Motor

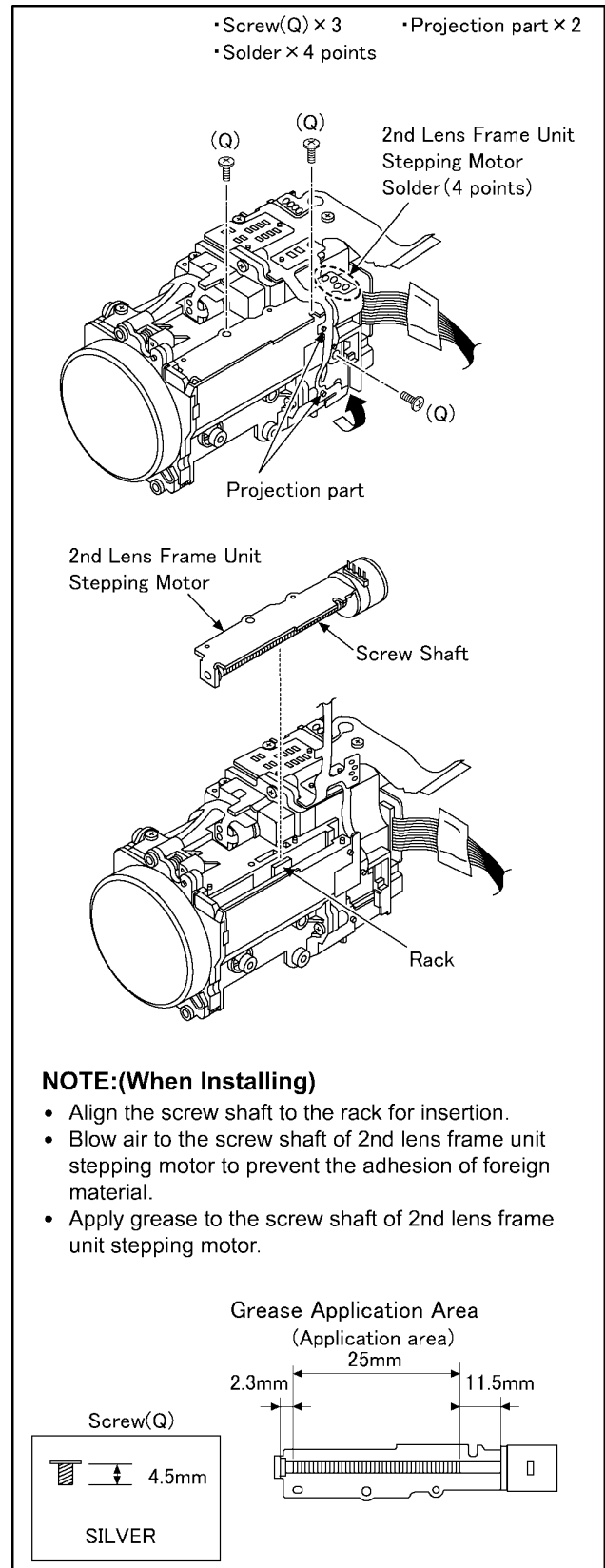

Fig. D21

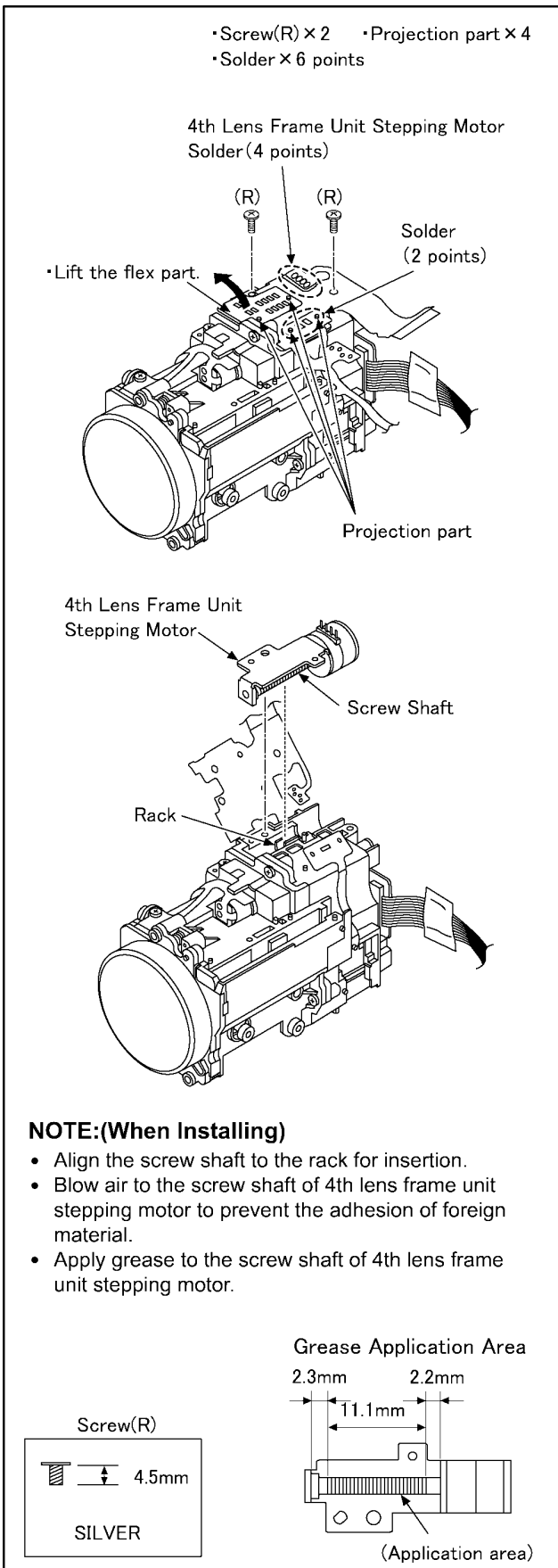

Fig. D22

9 Measurements and Adjustments

9.1. Electric Adjustment

- Adjustment method is different from a conventional High definition video camera.
- An exclusive jig and PC (including software for adjustment "Tatsujin") are necessary for electric adjustment.
- A USB driver for service is necessary to communication with PC.
- Connection method of the main unit and an exclusive adjustment jig as follows

9.1.1. Adjustment Procedure

- Connect the main unit to PC with USB.
The adjustment instruction is available at "Software download" on the "Support Information from NWBG/VDBG-AVC" web-site in "TSN System".

Figure of connection

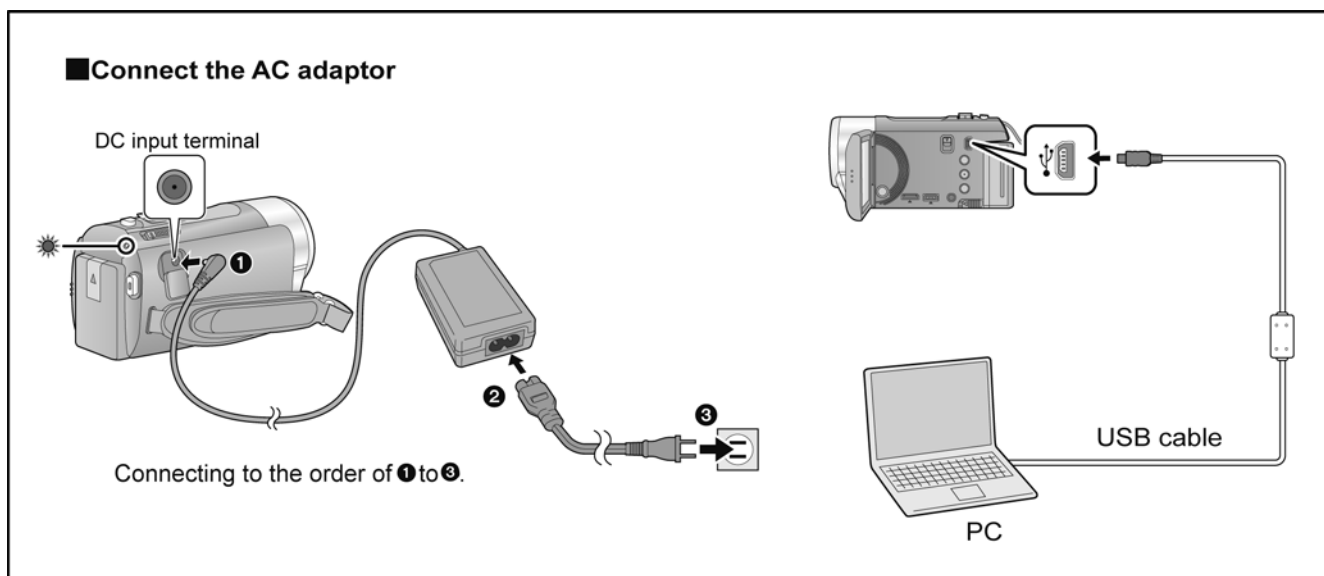
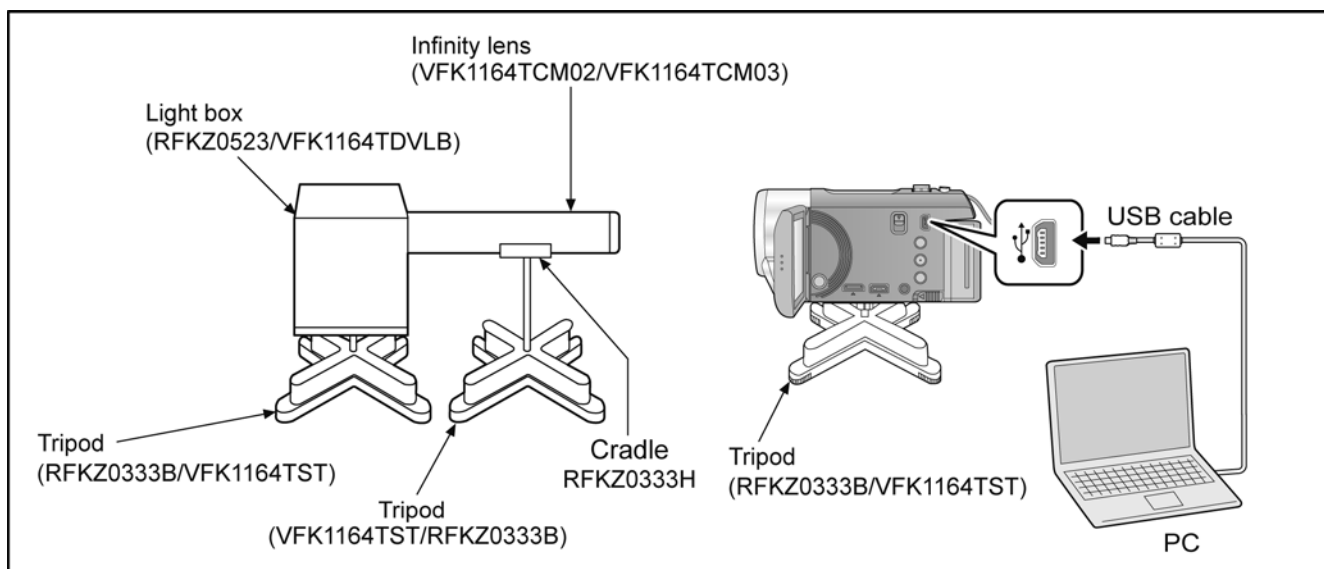

Figure of image when adjustment



Part Number of jig

- Only a necessary jig mentions it in setup of electric adjustment.

No.	Part Name	Part Number	Remarks
1	PC	-----	
2	AC Adaptor	-----	
3	USB Cable	-----	
4	Adjustment Software (Tatsujin)	-----	

Adjustment Items

- Adjustment item as follows.

The adjustment instruction is available at "Software download" on the "Support Information from NWBG/VDBG-AVC" web-site in "TSN System".

	Replacement part		Main P.C.B.	IC2002(EEPROM)	Lens Unit	MOS Unit	IC3701	IC3401, IC3402	IC701	IC6401
	Adjustment item									
Camera Part	● Hall amplifire/PWM bias/ OIS Hall amplifire adjustment (automatic)	<input type="radio"/>	<input type="radio"/>	<input type="radio"/>	<input type="radio"/>	<input type="radio"/>			<input type="radio"/>	<input type="radio"/>
	● OIS Sensor Offset adjustment (automatic)	<input type="radio"/>	<input type="radio"/>							<input type="radio"/>
	● Zoom tracking adjustment (automatic)	<input type="radio"/>	<input type="radio"/>	<input type="radio"/>	<input type="radio"/>				<input type="radio"/>	
	● Address wound revision (automatic)	<input type="radio"/>	<input type="radio"/>		<input type="radio"/>					
	● White balance adjustment (automatic)	<input type="radio"/>	<input type="radio"/>		<input type="radio"/>					
	● Gain adjustment between channels (automatic)	<input type="radio"/>	<input type="radio"/>		<input type="radio"/>					
Video Part	● Brightness level adjustment (automatic)	<input type="radio"/>	<input type="radio"/>				<input type="radio"/>			
	● UniPhier DDR revision (automatic)	<input type="radio"/>	<input type="radio"/>					<input type="radio"/>		

10 Factory Setting

10.1. How To Turn On The Factory Settings?

1. Set the mode switch "Motion Picture Recording" mode.
2. While the power is turned OFF, keep pressing the "Power" button, "Zoom lever" to W side and "intelligent auto/Manual" button for more than 3 seconds until the top screen of the Service Mode Menu being displayed.

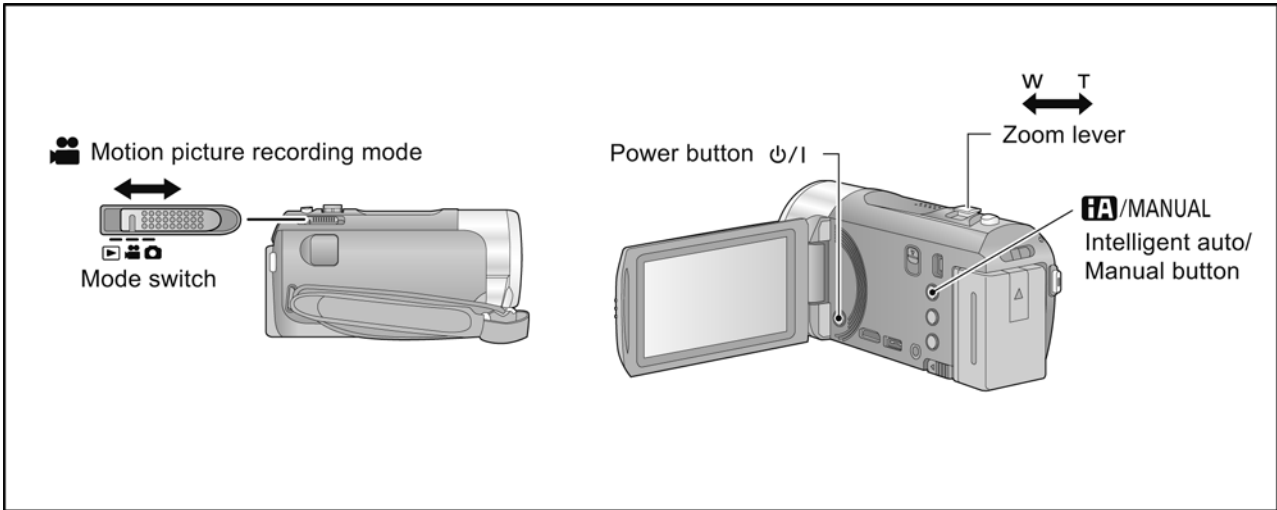

3. Touch the [1] of LCD.
4. Touch the [YES] of LCD.
5. After few seconds "END" is displayed or "ESD NODATA" as "NG" is displayed on LCD monitor. Cutting of battery connection or AC power supply connection as a completion of the "FACTORY SETTINGS".
(After use at least once, even if the physical format of the build-in memory will be performed, "ESD NODATA" as "NG" is indicated, but "FACTORY SETTINGS" is completed.)

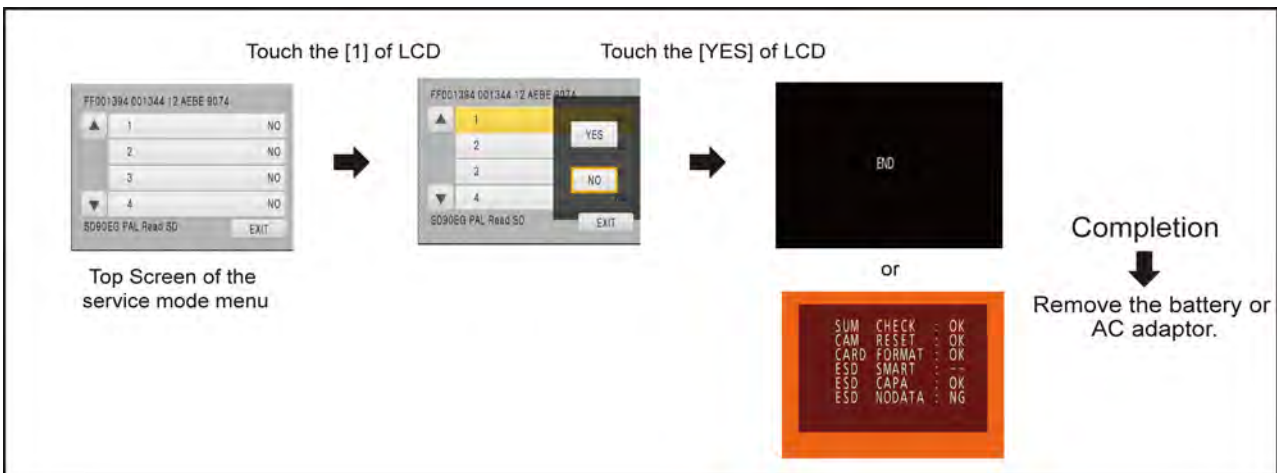

10.2. What Is The Factory Settings?

The factory settings clean up and/or refresh the following settings.

1. MENU, MODE, ADJUSTMENT VALUE.
2. SD card format.
3. Reset the folder number and file number of still pictures.
(Setting the folder number is 100, and file number is 0.)
4. Clear the mechanism lock information.
5. Clear the service mode information contents.
6. Close the lens cover
7. Initialize the VIERA Link Physical Address.

(HDC-TM90/TM99)

If the "Factory Settings" is completed, physical format of the built-in memory is not performed, execute physical format according to the following procedure.

To physically format the built-in memory, connect the unit via the AC adaptor, select [FORMAT Built-in Memory] → [YES] from the menu, and then press and hold the delete button on the screen below for about 3 seconds. When the built-in memory data deletion screen appears, select [YES], and then follow the on-screen instructions.

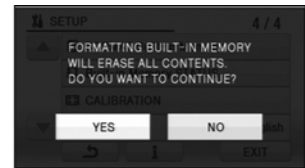

The setting position of factory settings:

Name	Setting position
Mode switch	Motion picture recording mode

Service Manual

Diagrams and Replacement Parts List

High Definition Video Camera

Model No.

HDC-SD90P	HDC-SD90EG	HDC-TM90P
HDC-SD90PC	HDC-SD90EP	HDC-TM90PC
HDC-SD90EB	HDC-SD90GC	HDC-TM90PU
HDC-SD90EC	HDC-SD90GN	HDC-TM90GK
HDC-SD90EE	HDC-SD90GK	HDC-TM99EG
HDC-SD90EF	HDC-SD99EG	

Vol. 1

Colour

(K).....Black Type

(S).....Silver Type (only HDC-SD99EG)

(H).....Glaz Type (only HDC-SD90EB)

Table of contents

S1. About Indication of The Schematic Diagram.....	S-1	S6. Replacement Parts List.....	S-11
S1.1. Important Safety Notice.....	S-1		
S2. Voltage Chart	S-2	S7. Exploded View	S-17
S2.1. SD P.C.B.	S-2	S7.1. Frame and Casing Section (1)	S-17
		S7.2. Frame and Casing Section (2)	S-18
S3. Block Diagram.....	S-3	S7.3. LCD Section.....	S-19
S3.1. Overall Block Diagram	S-3	S7.4. Packing Parts and Accessories Section.....	S-20
S4. Schematic Diagram.....	S-4		
S4.1. Interconnection Diagram	S-4		
S4.2. SD Schematic Diagram.....	S-5		
S4.3. Monitor Schematic Diagram.....	S-6		
S5. Print Circuit Board.....	S-7		
S5.1. SD P.C.B.	S-7		
S5.1.1. SD P.C.B. (Component Side)	S-7		
S5.1.2. SD P.C.B. (Foil Side).....	S-8		
S5.2. Monitor P.C.B.	S-9		
S5.2.1. Monitor P.C.B. (Component Side)	S-9		
S5.2.2. Monitor P.C.B. (Foil Side).....	S-10		

S1. About Indication of The Schematic Diagram

S1.1. Important Safety Notice

COMPONENTS IDENTIFIED WITH THE MARK \triangle HAVE THE SPECIAL CHARACTERISTICS FOR SAFETY. WHEN REPLACING ANY OF THESE COMPONENTS USE ONLY THE SAME TYPE.

1. Although reference number of the parts is indicated on the P.C.B. drawing and/or schematic diagrams, it is NOT mounted on the P.C.B. when it is displayed with "\$" mark.
2. It is only the "Test Round" and no terminal (Pin) is available on the P.C.B. when the TP (Test Point) indicated as "●" mark.
3. The voltage being indicated on the schematic diagram is measured in "Standard-Playback" mode when there is no specify mode is mentioned.
4. Although the voltage and waveform available on here is measured with standard frame, it may be differ from actual measurement due to modification of circuit and so on.
5. The voltage being indicated here may be include observational-error (deviation) due to internal-resistance and/or reactance of equipment. Therefore, handle the value indicated on here as reference.
6. Use the parts number indicated on the Replacement Parts List .
7. Indication on Schematic diagrams:

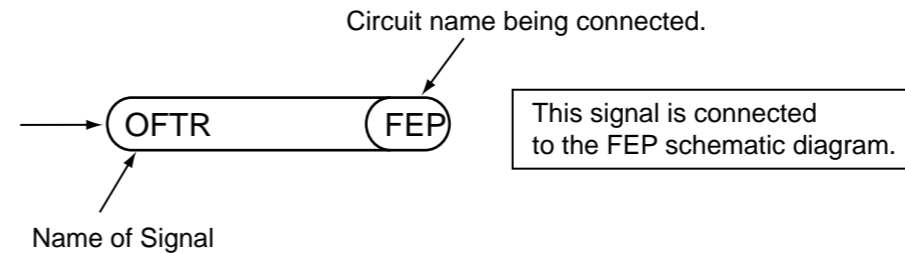

S2. Voltage Chart

Note) Indicated voltage values are the standard values for the unit measured by the DC electronic circuit tester (high-impedance) with the chassis taken as standard.
Therefore, there may exist some errors in the voltage values, depending on the internal impedance of the DC circuit tester.

S2.1. SD P.C.B.

REF No.	PIN No.	POWER ON
Q3901	E	3.2
Q3901	C	3.2
Q3901	B	3.2
QR6402	E	2.9
QR6402	C	-0.4
QR6402	B	2.9

S3. Block Diagram

S3.1. Overall Block Diagram

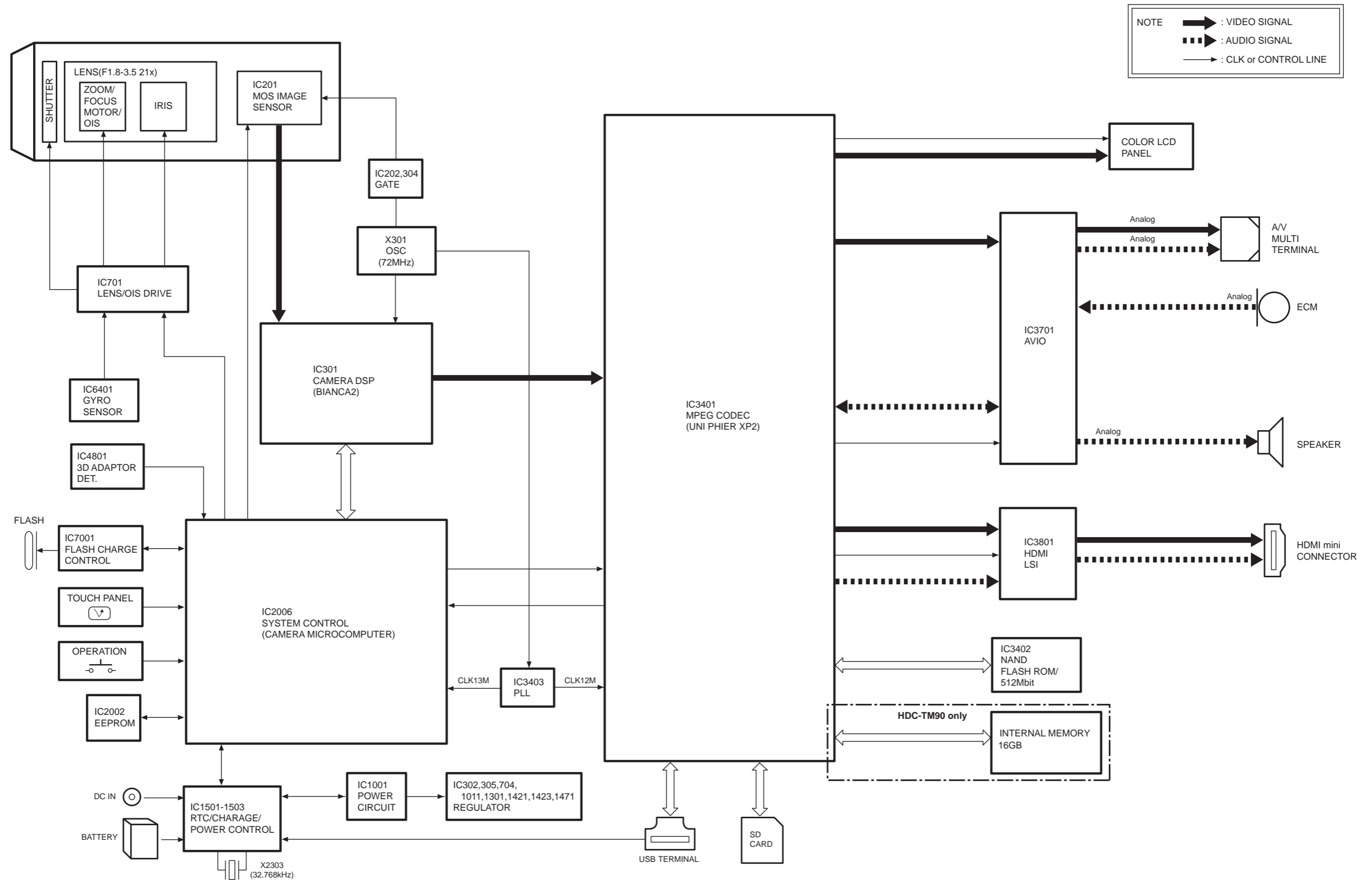

S4. Schematic Diagram

S4.1. Interconnection Diagram

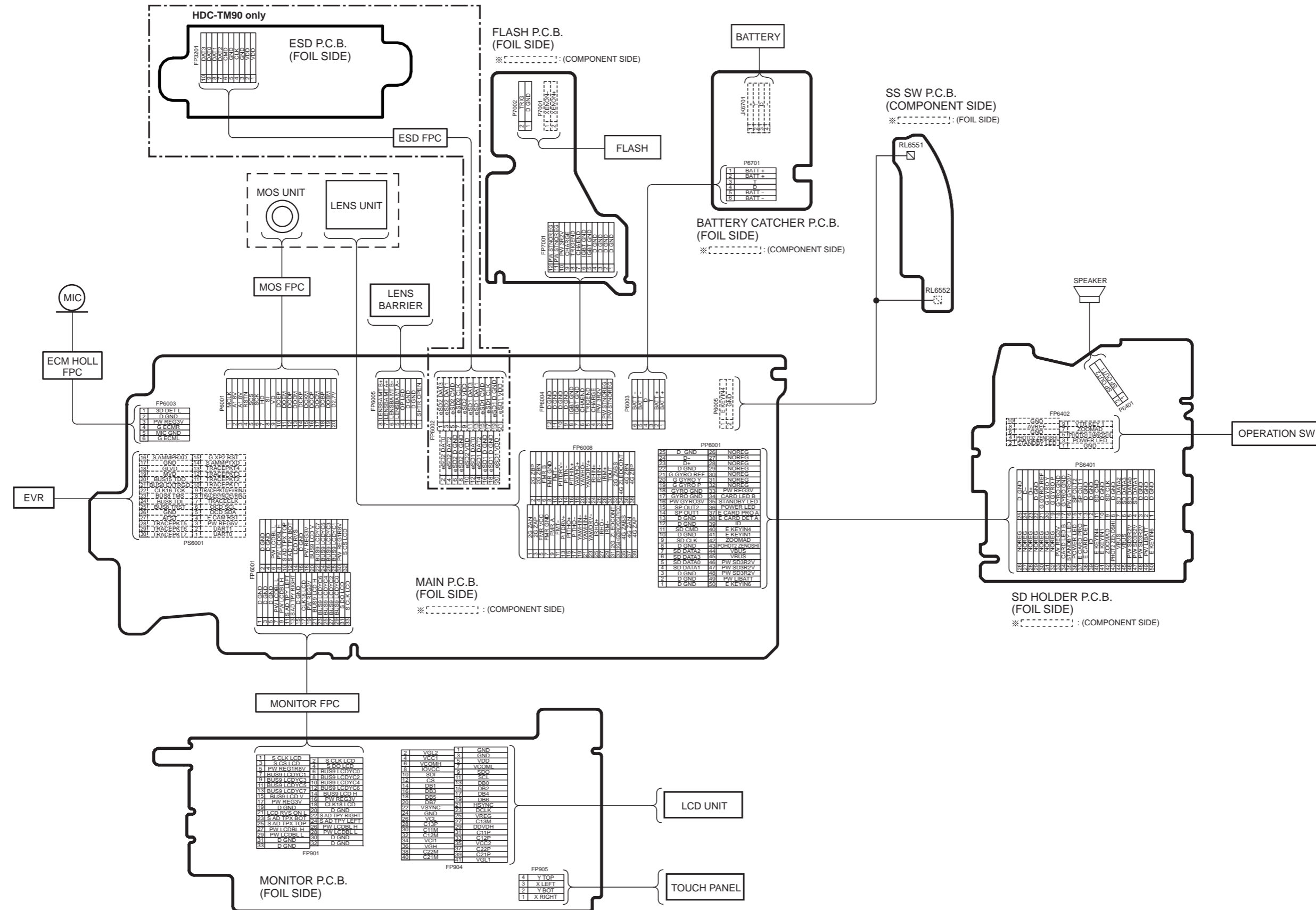

S4.2. SD Schematic Diagram

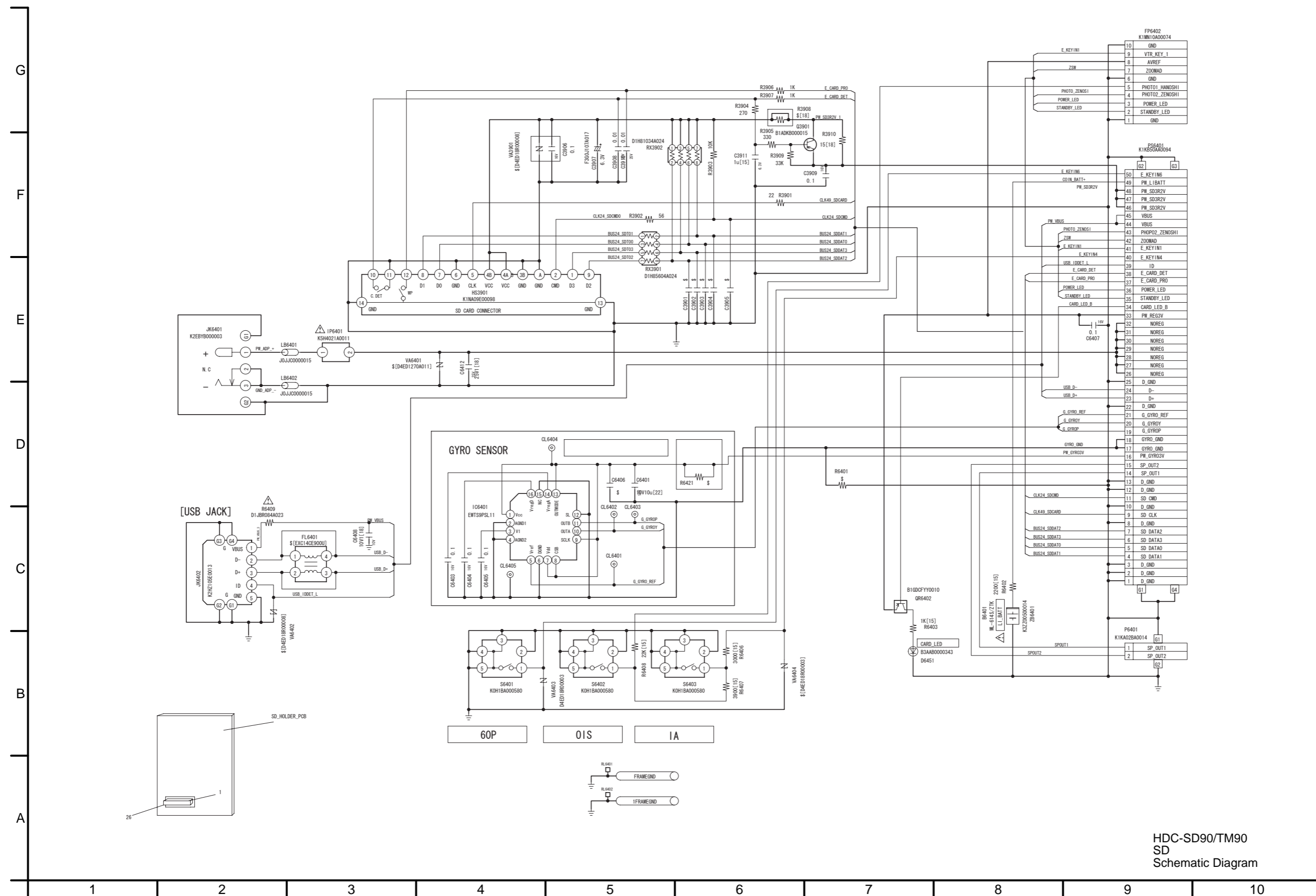

HDC-SD90/TM90
SD
Schematic Diagram

S4.3. Monitor Schematic Diagram

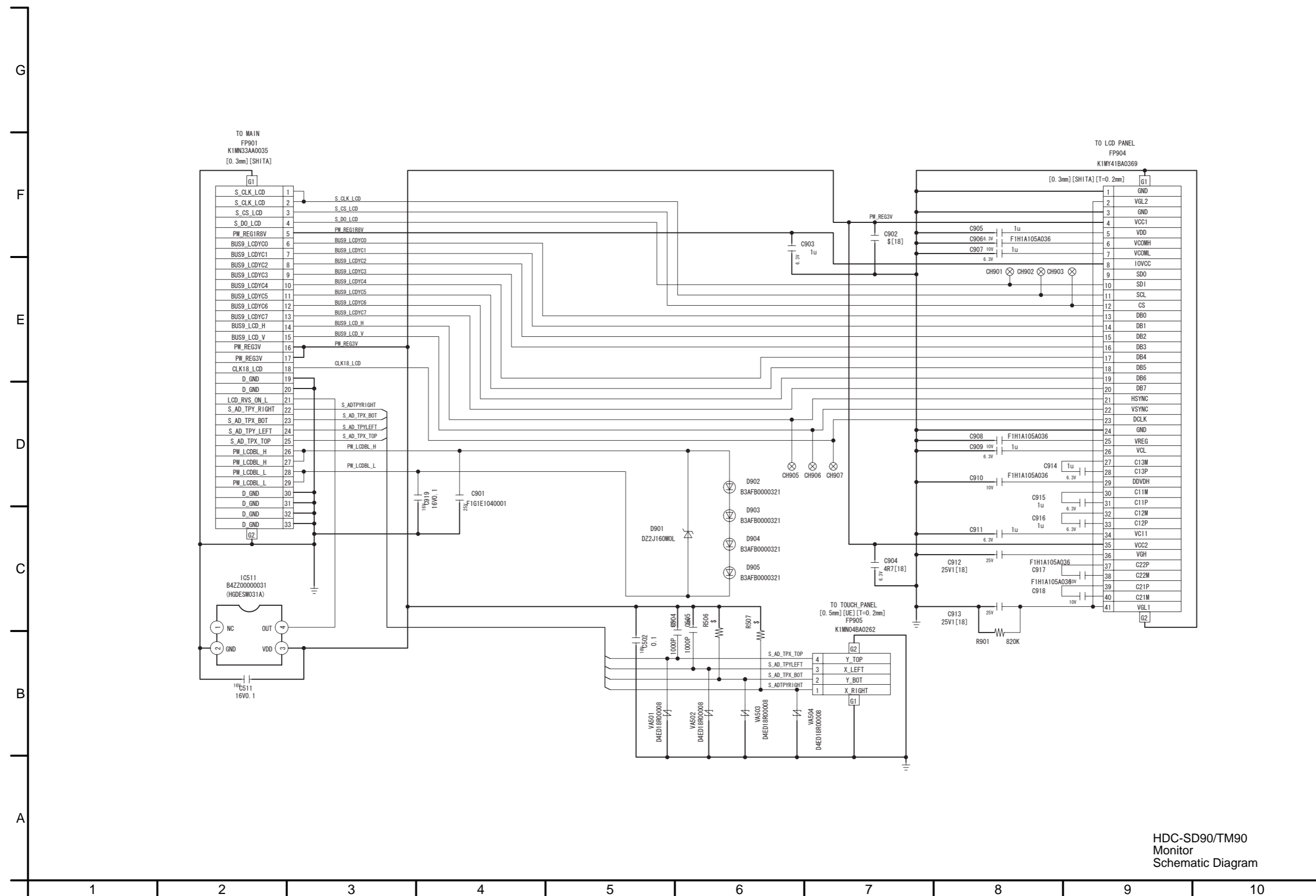

HDC-SD90/TM90
Monitor
Schematic Diagram

S5. Print Circuit Board

S5.1. SD P.C.B.

S5.1.1. SD P.C.B. (Component Side)

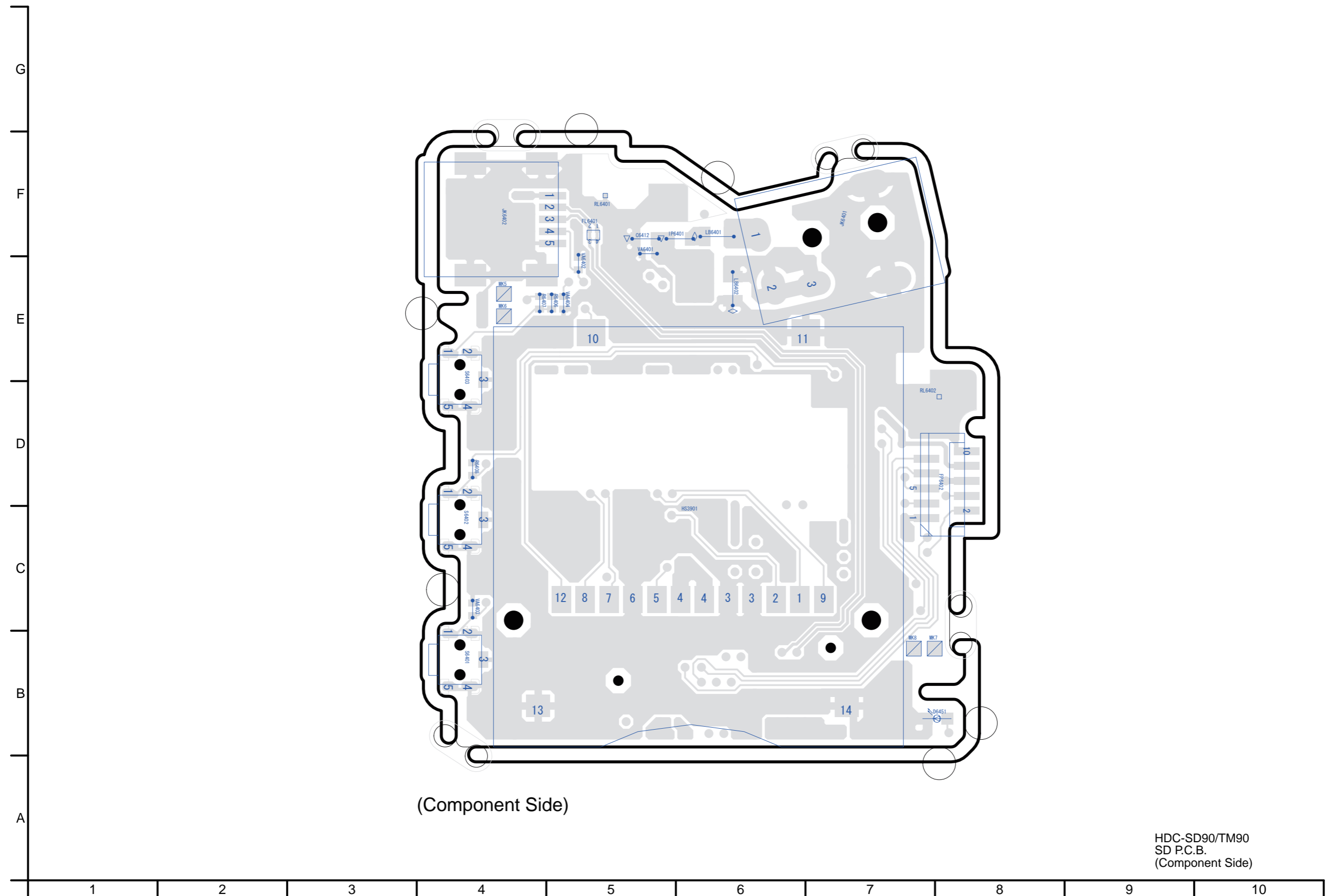

HDC-SD90/TM90
SD P.C.B.
(Component Side)

S5.1.2. SD P.C.B. (Foil Side)

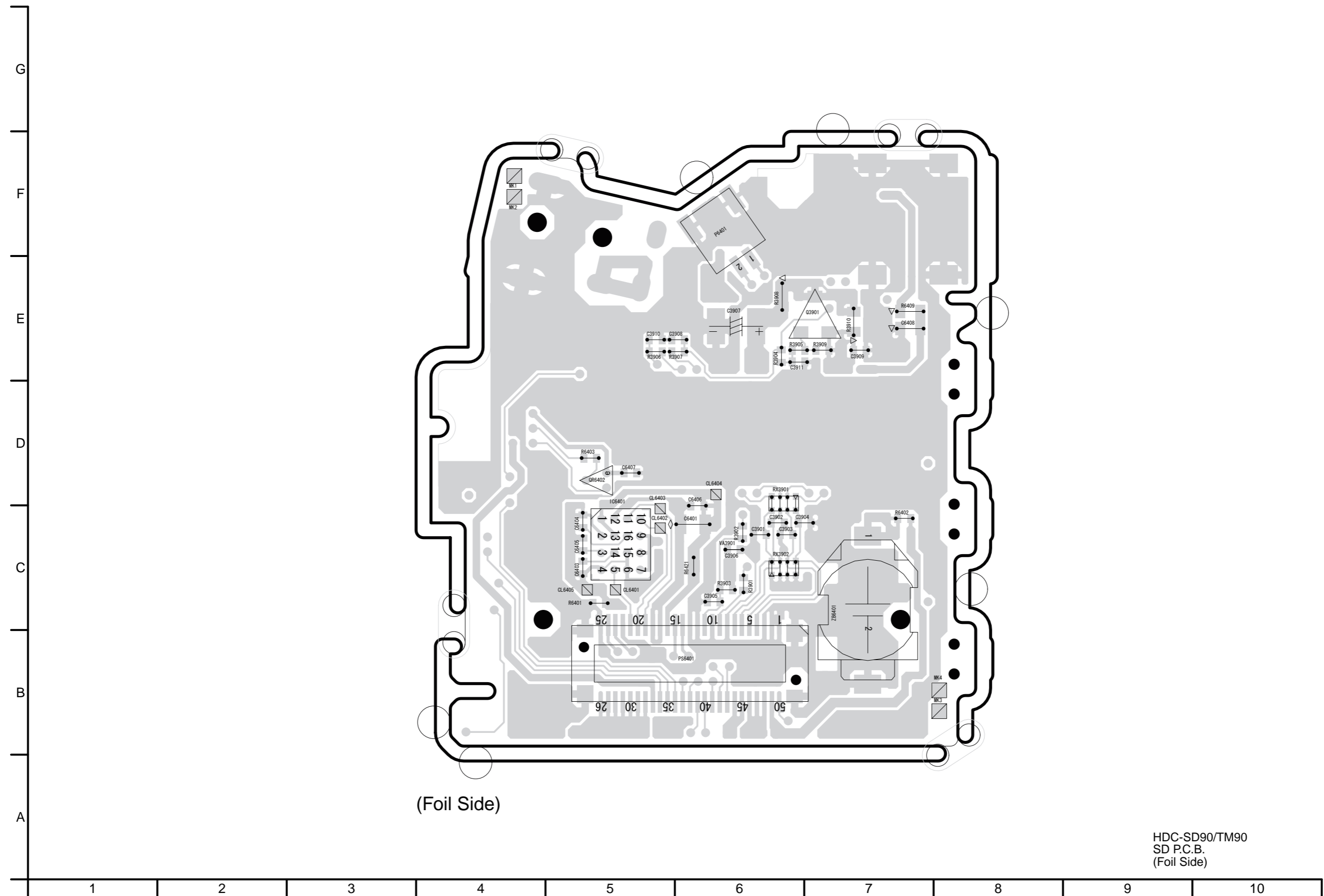

(Foil Side)

HDC-SD90/TM90
SD P.C.B.
(Foil Side)

S5.2. Monitor P.C.B.

S5.2.1. Monitor P.C.B. (Component Side)

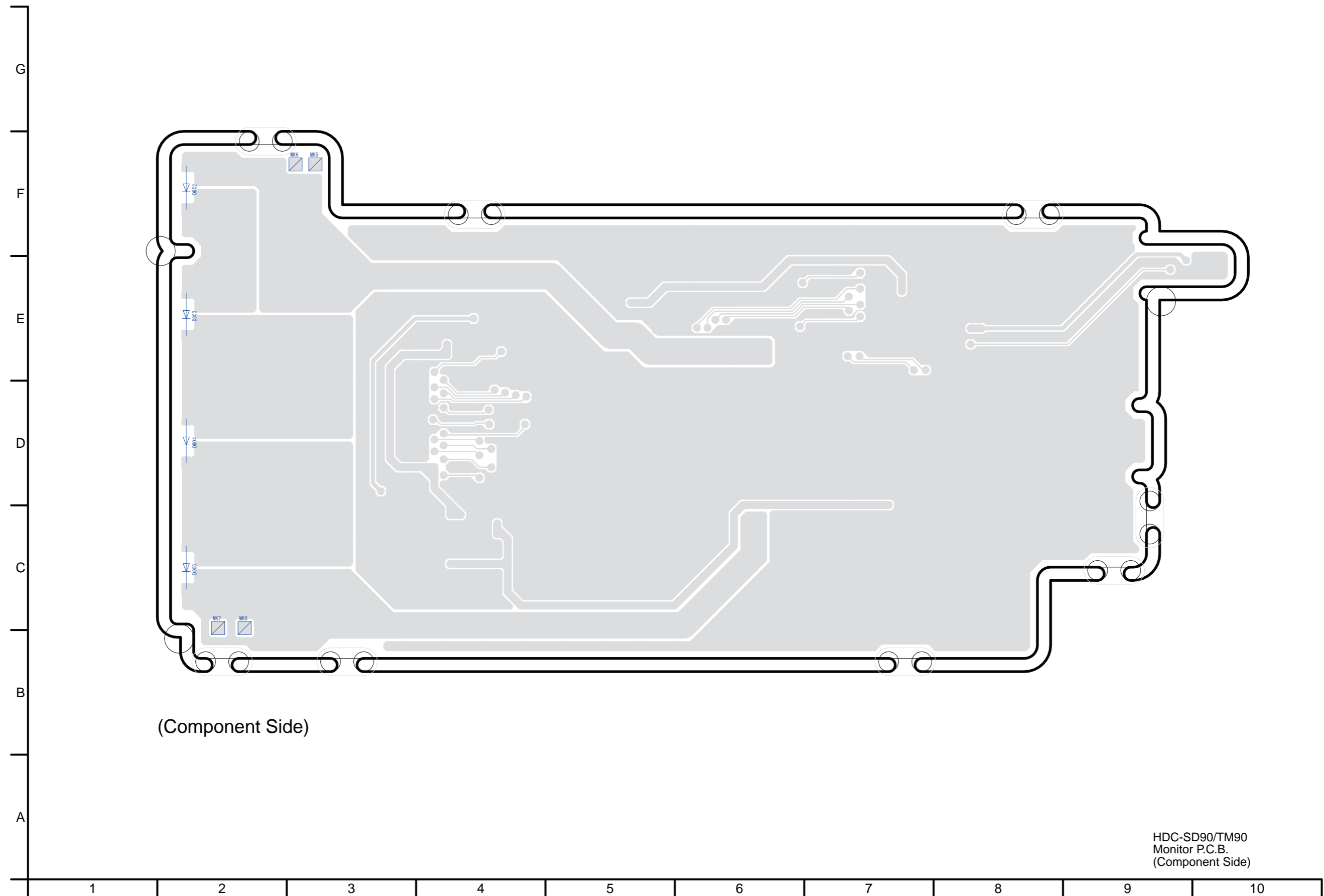

S5.2.2. Monitor P.C.B. (Foil Side)

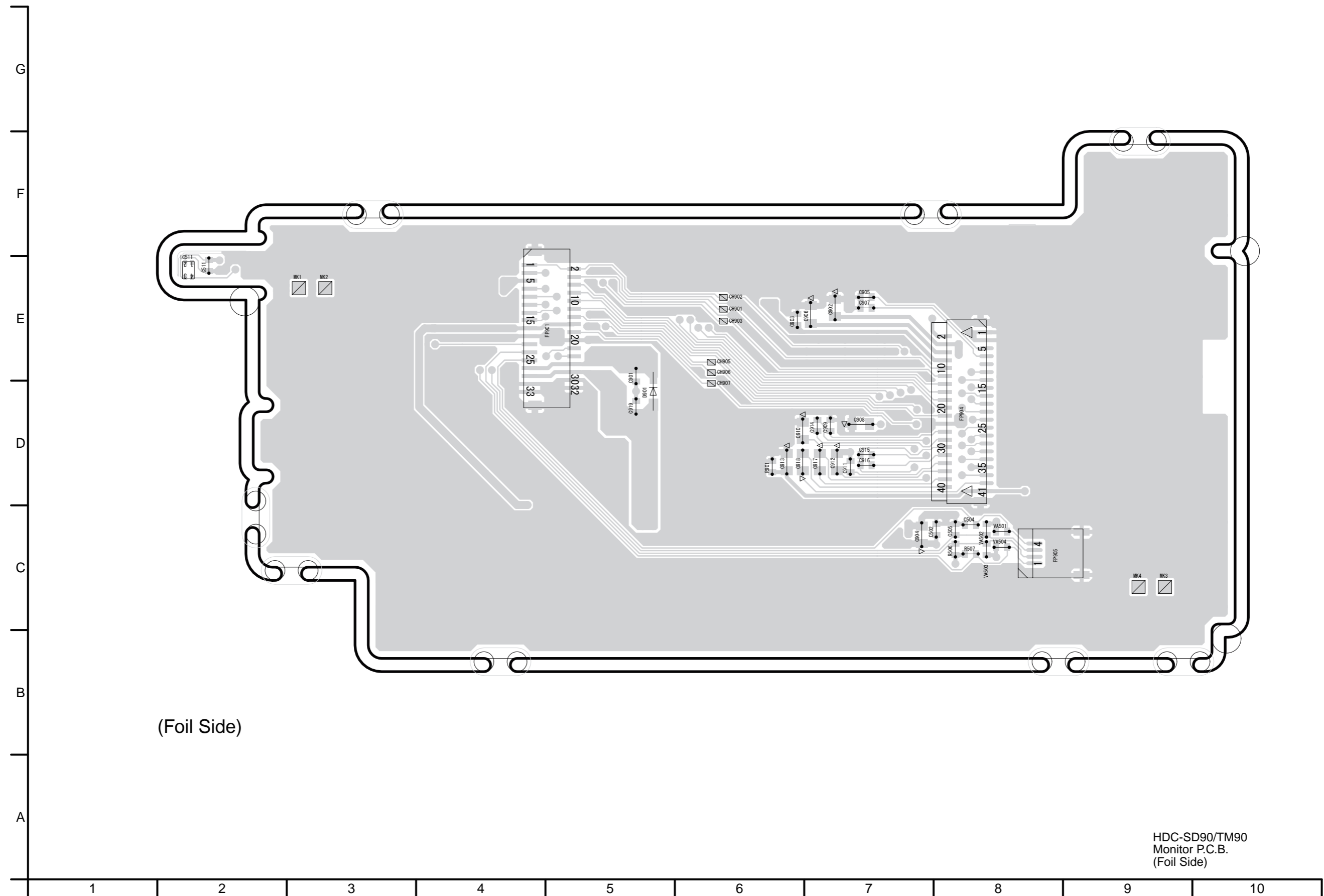

S6. Replacement Parts List

- Note: 1.* Be sure to make your orders of replacement parts according to this list.
2. IMPORTANT SAFETY NOTICE
Components identified with the mark \triangle have the special characteristics for safety.
When replacing any of these components, use only the same type.
3. Unless otherwise specified,
All resistors are in OHMS, K=1,000 OHMS. All capacitors are in MICRO-FARADS (uf), P=uuF.
4. The marking (RTL) indicates the retention time is limited for this item. After the discontinuation of this assembly in production, it will no longer be available.

E.S.D. standards for Electrostatically Sensitive Devices, refer to “PREVENTION OF ELECTROSTATIC DISCHARGE (ESD) TO ELECTROSTATICALLY SENSITIVE (ES) DEVICES” section.

Ref.No.	Part No.	Part Name & Description	Pcs	Remarks
##	VEP03J13CP	MAIN P.C.B. UNIT	1	(RTL) E.S.D. SD90EB,EC, EF,EG,EP, SD99EG
##	VEP03J13CQ	MAIN P.C.B. UNIT	1	(RTL) E.S.D. SD90EE,GC, GK,GN
##	VEP03J13CN	MAIN P.C.B. UNIT	1	(RTL) E.S.D. SD90P,PC
##	VEP03J13BQ	MAIN P.C.B. UNIT	1	(RTL) E.S.D. TM90GK
##	VEP03J13BN	MAIN P.C.B. UNIT	1	(RTL) E.S.D. TM90P,PC,PU
##	VEP03J13BP	MAIN P.C.B. UNIT	1	(RTL) E.S.D. TM99EG
##	VEP03J17A	SD HOLDER P.C.B. UNIT	1	(RTL) E.S.D.
##	VEP26340A	MONITOR P.C.B. UNIT	1	(RTL) E.S.D.
##	VEP03J17A	SD HOLDER P.C.B. UNIT	1	(RTL) E.S.D.
△ B6401	ML-614S/ZTK	BATTERY	1	[ENERGY]
C3906	F1G1C104A077	C.CAPACITOR CH 16V 0.1U	1	
C3907	F3G0J107A017	C.CAPACITOR CH 6.3V 100U	1	
C3908	F1G1E1030005	C.CAPACITOR CH 25V 0.01U	1	
C3909	F1G1C104A077	C.CAPACITOR CH 16V 0.1U	1	
C3910	F1G1E1030005	C.CAPACITOR CH 25V 0.01U	1	
C3911	F1G0J1050007	C.CAPACITOR CH 6.3V 1U	1	
C6401	F1J1A106A043	C.CAPACITOR CH 10V 10U	1	
C6403	F1G1C104A077	C.CAPACITOR CH 16V 0.1U	1	
C6404	F1G1C104A077	C.CAPACITOR CH 16V 0.1U	1	
C6405	F1G1C104A077	C.CAPACITOR CH 16V 0.1U	1	
C6407	F1G1C104A077	C.CAPACITOR CH 16V 0.1U	1	
C6408	ECJ1VB1A105K	C.CAPACITOR CH 10V 1U	1	
C6412	F1H1E105A116	C.CAPACITOR CH 25V 1U	1	
D6451	B3AAB0000343	LED	1	E.S.D.
FP6402	K1MN10A00074	CONNECTOR 10P	1	
HS3901	K1NA09E00098	SD CARD CONNECTOR	1	
IC6401	EWTS9P5L11	IC	1	E.S.D.
△ IP6401	K5H4021A0011	IC PROTECTOR	1	
JK6401	K2EBYB000003	JACK	1	
JK6402	K2HZ105E0013	JK, USB	1	
LB6401	J0JJC0000015	FILTER	1	
LB6402	J0JJC0000015	FILTER	1	
P6401	K1KA02BA0014	CONNECTOR 2P	1	
PS6401	K1KB50AA0094	CONNECTOR 50P	1	
Q3901	B1ADKB0000015	TRANSISTOR	1	E.S.D.
QR6402	B1GDCFFY0010	TRANSISTOR	1	E.S.D.
R3901	ERJ2GEJ220	M.RESISTOR CH 1/16W 22	1	
R3902	ERJ2GEJ560X	M.RESISTOR CH 1/10W 56	1	
R3903	ERJ2GEJ103	M.RESISTOR CH 1/10W 10K	1	
R3904	ERJ2GEJ271	M.RESISTOR CH 1/10W 270	1	
R3905	ERJ2GEJ331	M.RESISTOR CH 1/16W 330	1	
R3906	ERJ2GEJ102Y	M.RESISTOR CH 1/10W 1K	1	
R3907	ERJ2GEJ102Y	M.RESISTOR CH 1/10W 1K	1	
R3909	ERJ2GEJ333	M.RESISTOR CH 1/16W 33K	1	
R3910	D0GB150JA057	M.RESISTOR CH 1/10W 15	1	
R6402	ERJ2GEJ222	M.RESISTOR CH 1/10W 2.2K	1	
R6403 02	ERJ2GEJ102Y	M.RESISTOR CH 1/10W 1K	1	
R6406 02	ERJ2GEJ302	M.RESISTOR CH 1/16W 3K	1	
R6407 02	ERJ2GEJ392	M.RESISTOR CH 1/10W 3.9K	1	
R6408 02	ERJ2GEJ223	M.RESISTOR CH 1/16W 22K	1	
△ R6409	D1JBR084A023	FUSE RESISTOR	1	
RX3901	D1H85604A024	RESISTOR NETWORKS	1	
RX3902	EXB28V103JX	RESISTOR NETWORKS	1	
S6401	K0H1BA000580	SWITCH	1	
S6402	K0H1BA000580	SWITCH	1	

Ref.No.	Part No.	Part Name & Description	Pcs	Remarks
S6403	K0H1BA000580	SWITCH	1	
VA6403	D4ED18R00003	VARISTOR	1	
ZB6401	K3ZZ00500014	BATTERY HOLDER	1	
##	VEP26340A	MONITOR P.C.B. UNIT	1	(RTL) E.S.D.
C502	F1G1C104A077	C.CAPACITOR CH 16V 0.1U	1	
C504	F1G1H102A640	C.CAPACITOR CH 50V 1000P	1	
C505	F1G1H102A640	C.CAPACITOR CH 50V 1000P	1	
C511	F1G1C104A077	C.CAPACITOR CH 16V 0.1U	1	
C901	F1G1E1040001	C.CAPACITOR CH 25V 0.1U	1	
C903	F1G0J1050007	C.CAPACITOR CH 6.3V 1U	1	
C904	F1H0J4750004	C.CAPACITOR CH 6.3V 4.7U	1	
C905	F1G0J1050007	C.CAPACITOR CH 6.3V 1U	1	
C906	F1H1A105A036	C.CAPACITOR CH 10V 1U	1	
C907	F1G0J1050007	C.CAPACITOR CH 6.3V 1U	1	
C908	F1H1A105A036	C.CAPACITOR CH 10V 1U	1	
C909	F1G0J1050007	C.CAPACITOR CH 6.3V 1U	1	
C910	F1H1A105A036	C.CAPACITOR CH 10V 1U	1	
C911	F1G0J1050007	C.CAPACITOR CH 6.3V 1U	1	
C912	F1H1E105A116	C.CAPACITOR CH 25V 1U	1	
C913	F1H1E105A116	C.CAPACITOR CH 25V 1U	1	
C914	F1G0J1050007	C.CAPACITOR CH 6.3V 1U	1	
C915	F1G0J1050007	C.CAPACITOR CH 6.3V 1U	1	
C916	F1G0J1050007	C.CAPACITOR CH 6.3V 1U	1	
C917	F1H1A105A036	C.CAPACITOR CH 10V 1U	1	
C918	F1H1A105A036	C.CAPACITOR CH 10V 1U	1	
C919	F1G1C104A077	C.CAPACITOR CH 16V 0.1U	1	
D901	DZ2J160MOL	DIODE	1	E.S.D.
D902	B3AFB0000321	DIODE	1	E.S.D.
D903	B3AFB0000321	DIODE	1	E.S.D.
D904	B3AFB0000321	DIODE	1	E.S.D.
D905	B3AFB0000321	DIODE	1	E.S.D.
FP901	K1MN33AA0035	CONNECTOR 30P	1	
FP904	K1MY41BA0369	CONNECTOR 41P	1	
FP905	K1MN04BA0262	CONNECTOR 4P	1	
IC511	B4ZZ00000031	IC	1	E.S.D.
R901	ERJ2GEJ824	M.RESISTOR CH 1/16W 820K	1	
VA501	D4ED18R00008	VARISTOR	1	
VA502	D4ED18R00008	VARISTOR	1	
VA503	D4ED18R00008	VARISTOR	1	
VA504	D4ED18R00008	VARISTOR	1	

S7. Exploded View

S7.1. Frame and Casing Section (1)

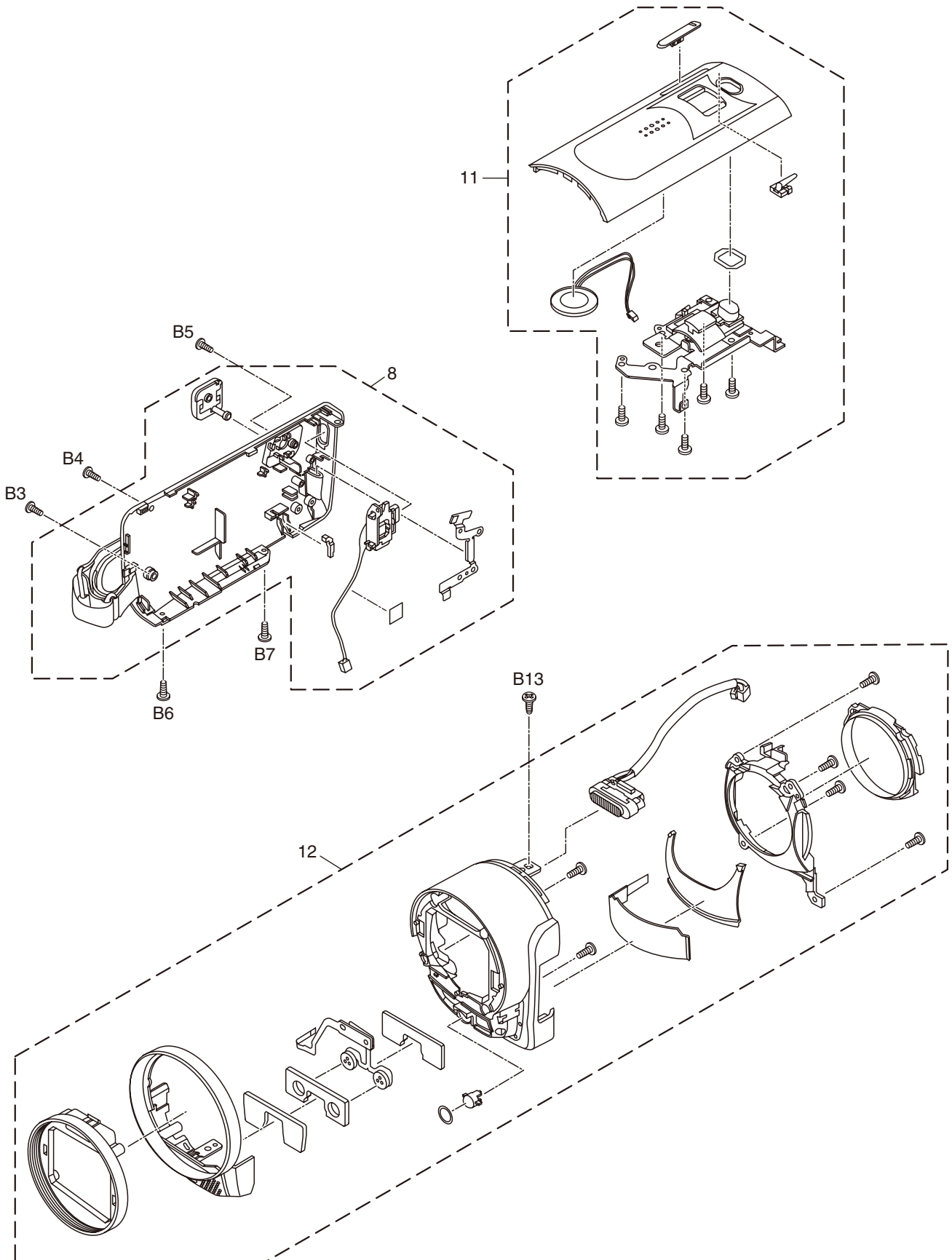

S7.2. Frame and Casing Section (2)

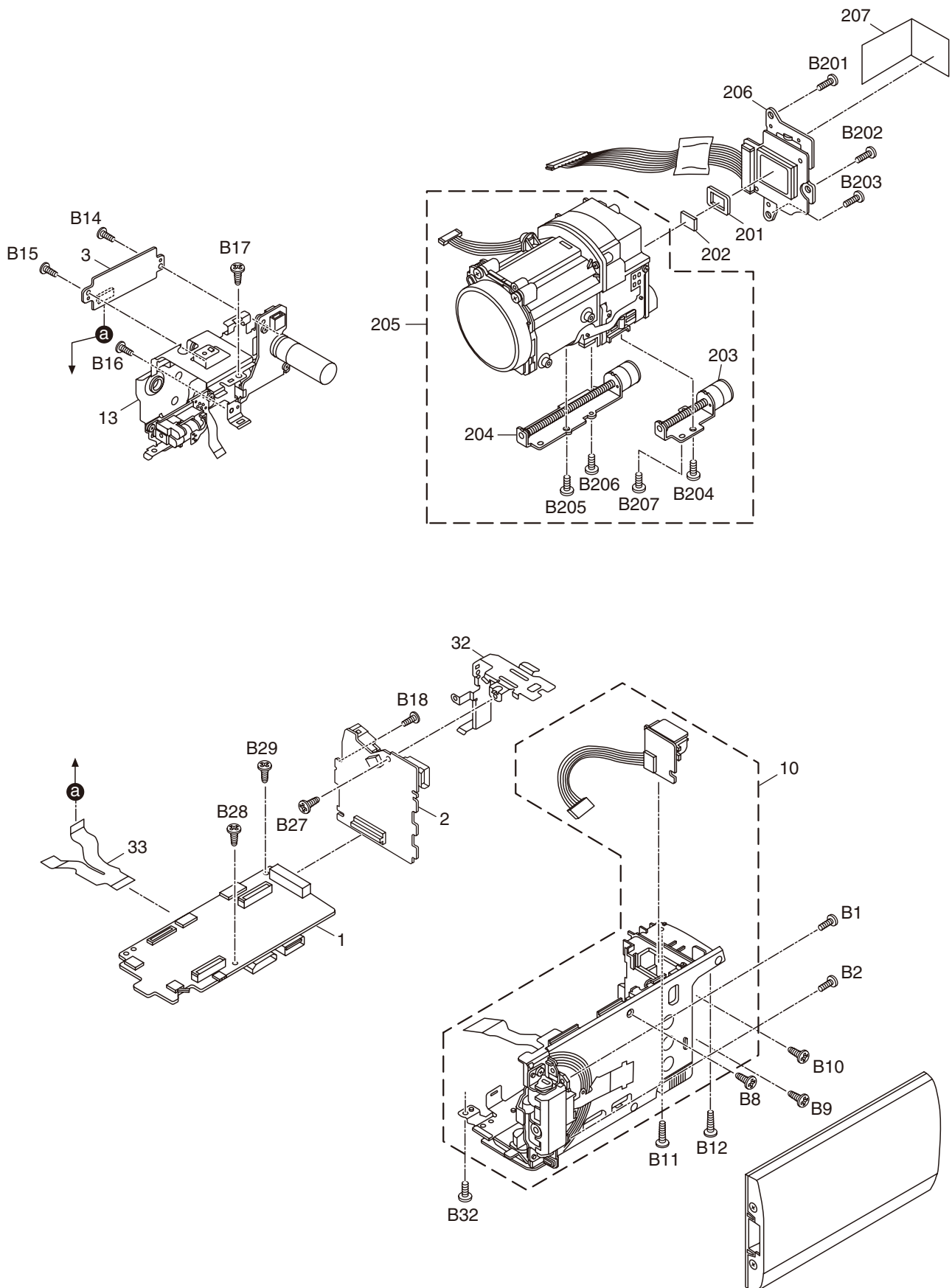

S7.3. LCD Section

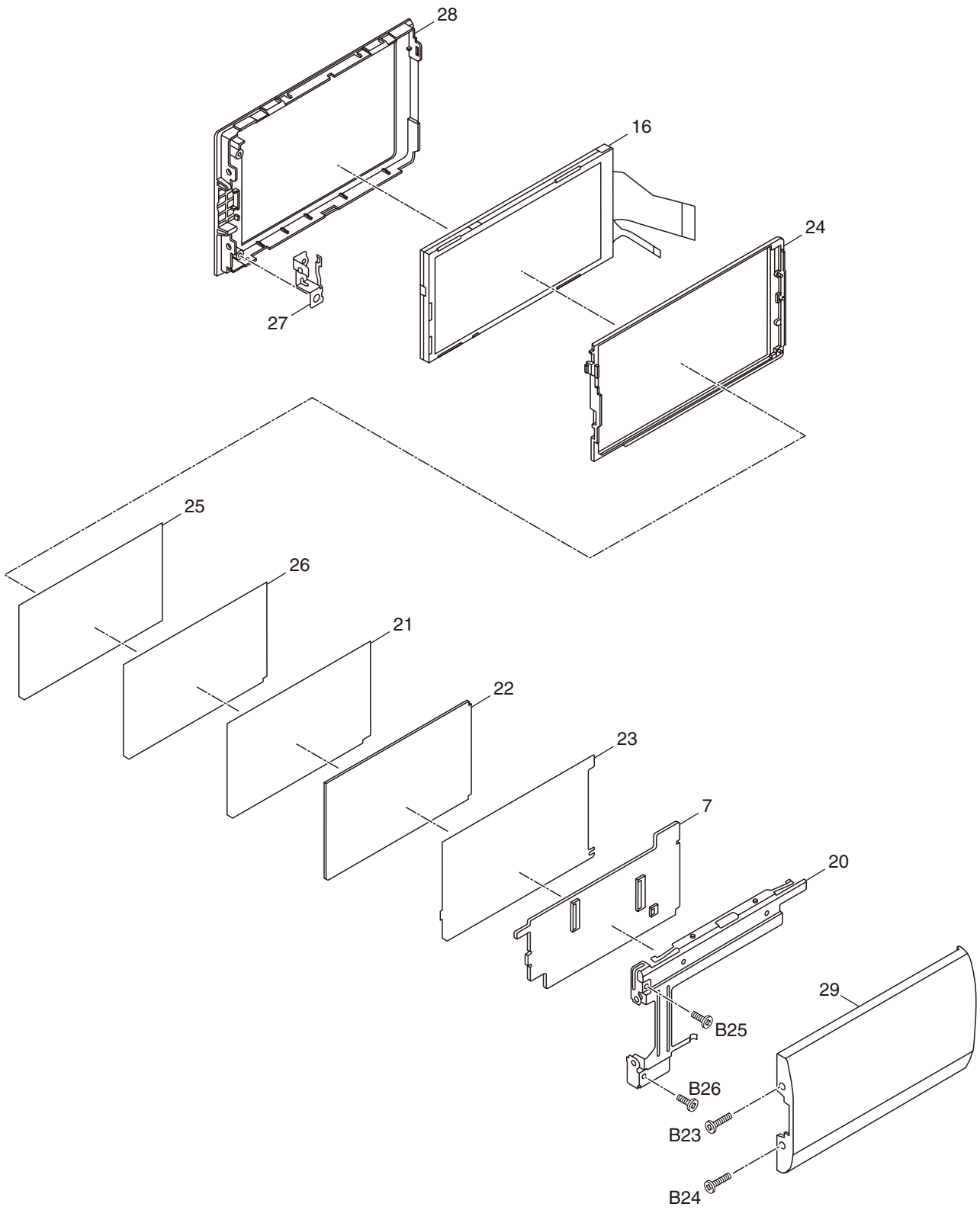

S7.4. Packing Parts and Accessories Section

