

Service Manual

High Definition Video Camera

AVCHD™

DOLBY
DIGITAL
STEREO CREATOR

SD
XC

HDMI VIERA Link™

Model No. **HDC-HS80P**

HDC-HS80PC

HDC-HS80PU

HDC-HS80EB

HDC-HS80EC

HDC-HS80EE

HDC-HS80EG

HDC-HS80EP

HDC-HS80GA

HDC-HS80GC

HDC-HS80GN

HDC-HS80GT

HDC-HS80GK

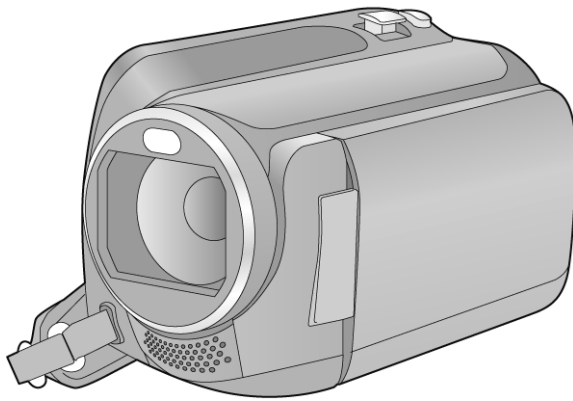

Vol. 1

Colour

(K).....Black Type

⚠ WARNING

This service information is designed for experienced repair technicians only and is not designed for use by the general public. It does not contain warnings or cautions to advise non-technical individuals of potential dangers in attempting to service a product. Products powered by electricity should be serviced or repaired only by experienced professional technicians. Any attempt to service or repair the product or products dealt with in this service information by anyone else could result in serious injury or death.

Panasonic®

© Panasonic Corporation 2011 Unauthorized copying and distribution is a violation of law.

TABLE OF CONTENTS

| | PAGE | PAGE |
|---|-----------|------|
| 1 Safety Precautions | 3 | |
| 1.1. General Guidelines | 3 | |
| 1.2. Leakage Current Cold Check | 3 | |
| 1.3. Leakage Current Hot Check (See Figure 1.) | 3 | |
| 2 Warning | 4 | |
| 2.1. Prevention of Electrostatic Discharge (ESD) to Electrostatically Sensitive (ES) Devices | 4 | |
| 2.2. How to Recycle the Lithium Ion Battery (U.S. Only) | 4 | |
| 2.3. Caution for AC Cord (For EB/GC) | 5 | |
| 2.4. How to Replace the Lithium Battery | 6 | |
| 3 Service Navigation | 7 | |
| 3.1. Introduction | 7 | |
| 3.2. General Description About Lead Free Solder (PbF) | 7 | |
| 3.3. Important Notice 1:(Other than U.S.A. and Canadian Market) | 7 | |
| 3.4. How to Define the Model Suffix (NTSC or PAL model) | 8 | |
| 3.5. Precautions for Handling HDD | 9 | |
| 3.6. Formatting | 13 | |
| 4 Specifications | 14 | |
| 5 Location of Controls and Components | 16 | |
| 6 Service Mode | 20 | |
| 6.1. Drive Information Display | 21 | |
| 6.2. HDD Self Check Execution | 21 | |
| 6.3. Lock Search History Indication | 22 | |
| 6.4. Power ON Self Check Result Display | 22 | |
| 6.5. HDD Hardware Test | 23 | |
| 6.6. Erasing the lock histories | 23 | |
| 6.7. Erasing the internal media management information | 24 | |
| 6.8. Camera data indications while the video playback | 25 | |
| 7 Service Fixture & Tools | 26 | |
| 7.1. When Replacing the Main P.C.B. | 26 | |
| 7.2. Service Position | 26 | |
| 8 Disassembly and Assembly Instructions | 28 | |
| 8.1. Disassembly Flow Chart for the Unit | 28 | |
| 8.2. PCB Location | 28 | |
| 8.3. Disassembly Procedure for the Unit | 29 | |
| 9 Measurements and Adjustments | 35 | |
| 9.1. Electric Adjustment | 35 | |
| 10 Factory Setting | 37 | |
| 10.1. How To Turn On The Factory Settings? | 37 | |
| 10.2. What Is The Factory Settings? | 38 | |

1 Safety Precautions

1.1. General Guidelines

1. IMPORTANT SAFETY NOTICE

There are special components used in this equipment which are important for safety. These parts are marked by

 in the Schematic Diagrams, Circuit Board Layout, Exploded Views and Replacement Parts List. It is essential that these critical parts should be replaced with manufacturer's specified parts to prevent X-RADIATION, shock, fire, or other hazards. Do not modify the original design without permission of manufacturer.

2. An Isolation Transformer should always be used during the servicing of AC Adaptor whose chassis is not isolated from the AC power line. Use a transformer of adequate power rating as this protects the technician from accidents resulting in personal injury from electrical shocks. It will also protect AC Adaptor from being damaged by accidental shorting that may occur during servicing.
3. When servicing, observe the original lead dress. If a short circuit is found, replace all parts which have been overheated or damaged by the short circuit.
4. After servicing, see to it that all the protective devices such as insulation barriers, insulation papers shields are properly installed.
5. After servicing, make the following leakage current checks to prevent the customer from being exposed to shock hazards.

1.2. Leakage Current Cold Check

1. Unplug the AC cord and connect a jumper between the two prongs on the plug.
2. Measure the resistance value, with an ohmmeter, between the jumpered AC plug and each exposed metallic cabinet part on the equipment such as screwheads, connectors, control shafts, etc. When the exposed metallic part has a return path to the chassis, the reading should be between $1\text{ M}\Omega$ and $5.2\text{ M}\Omega$. When the exposed metal does not have a return path to the chassis, the reading must be infinity.

1.3. Leakage Current Hot Check (See Figure 1.)

1. Plug the AC cord directly into the AC outlet. Do not use an isolation transformer for this check.
2. Connect a $1.5\text{ k}\Omega$, 10 W resistor, in parallel with a $0.15\text{ }\mu\text{F}$ capacitor, between each exposed metallic part on the set and a good earth ground, as shown in Figure 1.
3. Use an AC voltmeter, with $1\text{ k}\Omega/\text{V}$ or more sensitivity, to measure the potential across the resistor.
4. Check each exposed metallic part, and measure the voltage at each point.
5. Reverse the AC plug in the AC outlet and repeat each of the above measurements.
6. The potential at any point should not exceed 0.75 V RMS . A leakage current tester (Simpson Model 229 or equivalent) may be used to make the hot checks, leakage current must not exceed $1/2\text{ mA}$. In case a measurement is outside of the limits specified, there is a possibility of a shock hazard, and the equipment should be repaired and rechecked before it is returned to the customer.

Hot-Check Circuit

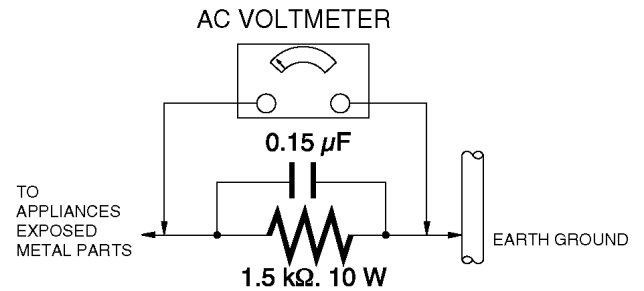

Figure. 1

2 Warning

2.1. Prevention of Electrostatic Discharge (ESD) to Electrostatically Sensitive (ES) Devices

Some semiconductor (solid state) devices can be damaged easily by static electricity. Such components commonly are called Electrostatically Sensitive (ES) Devices. Examples of typical ES devices are integrated circuits and some field-effect transistors and semiconductor "chip" components. The following techniques should be used to help reduce the incidence of component damage caused by electrostatic discharge (ESD).

1. Immediately before handling any semiconductor component or semiconductor-equipped assembly, drain off any ESD on your body by touching a known earth ground. Alternatively, obtain and wear a commercially available discharging ESD wrist strap, which should be removed for potential shock reasons prior to applying power to the unit under test.
2. After removing an electrical assembly equipped with ES devices, place the assembly on a conductive surface such as aluminum foil, to prevent electrostatic charge buildup or exposure of the assembly.
3. Use only a grounded-tip soldering iron to solder or unsolder ES devices.
4. Use only an antistatic solder removal device. Some solder removal devices not classified as "antistatic (ESD protected)" can generate electrical charge sufficient to damage ES devices.
5. Do not use freon-propelled chemicals. These can generate electrical charges sufficient to damage ES devices.
6. Do not remove a replacement ES device from its protective package until immediately before you are ready to install it. (Most replacement ES devices are packaged with leads electrically shorted together by conductive foam, aluminum foil or comparable conductive material).
7. Immediately before removing the protective material from the leads of a replacement ES device, touch the protective material to the chassis or circuit assembly into which the device will be installed.

CAUTION :

Be sure no power is applied to the chassis or circuit, and observe all other safety precautions.

8. Minimize bodily motions when handling unpackaged replacement ES devices. (Otherwise harmless motion such as the brushing together of your clothes fabric or the lifting of your foot from a carpeted floor can generate static electricity (ESD) sufficient to damage an ES device).

2.2. How to Recycle the Lithium Ion Battery (U.S. Only)

ENGLISH



A lithium ion/polymer battery that is recyclable powers the product you have purchased. Please call 1-800-8-BATTERY for information on how to recycle this battery.

FRANÇAIS



L'appareil que vous vous êtes procuré est alimenté par une batterie au lithium-ion/lithium-polymère. Pour des renseignements sur le recyclage de la batterie, veuillez composer le 1-800-8-BATTERY.

2.3. Caution for AC Cord (For EB/GC)

2.3.1. Information for Your Safety

IMPORTANT

Your attention is drawn to the fact that recording of pre-recorded tapes or discs or other published or broadcast material may infringe copyright laws.

WARNING

To reduce the risk of fire or shock hazard, do not expose this equipment to rain or moisture.

CAUTION

To reduce the risk of fire or shock hazard and annoying interference, use the recommended accessories only.

FOR YOUR SAFETY

DO NOT REMOVE THE OUTER COVER

To prevent electric shock, do not remove the cover. No user serviceable parts inside. Refer servicing to qualified service personnel.

2.3.2. Caution for AC Mains Lead

For your safety, please read the following text carefully.

This appliance is supplied with a moulded three-pin mains plug for your safety and convenience.

A 5-ampere fuse is fitted in this plug.

Should the fuse need to be replaced please ensure that the replacement fuse has a rating of 5 amperes and it is approved by ASTA or BSI to BS1362

Check for the ASTA mark or the BSI mark on the body of the fuse.



If the plug contains a removable fuse cover you must ensure that it is refitted when the fuse is replaced.

If you lose the fuse cover, the plug must not be used until a replacement cover is obtained.

A replacement fuse cover can be purchased from your local Panasonic Dealer.

If the fitted moulded plug is unsuitable for the socket outlet in your home then the fuse should be removed and the plug cut off and disposed of safely.

There is a danger of severe electrical shock if the cut off plug is inserted into any 13-ampere socket.

If a new plug is to be fitted please observe the wiring code as shown below.

If in any doubt, please consult a qualified electrician.

2.3.2.1. Important

The wires in this mains lead are coloured in accordance with the following code:

| | |
|-------|---------|
| Blue | Neutral |
| Brown | Live |

As the colours of the wires in the mains lead of this appliance may not correspond with the coloured markings identifying the terminals in your plug, proceed as follows:

The wire which is coloured BLUE must be connected to the terminal in the plug which is marked with the letter N or coloured BLACK.

The wire which is coloured BROWN must be connected to the terminal in the plug which is marked with the letter L or coloured RED.

Under no circumstances should either of these wires be connected to the earth terminal of the three pin plug, marked with the letter E or the Earth Symbol.



2.3.2.2. Before Use

Remove the Connector Cover as follows.

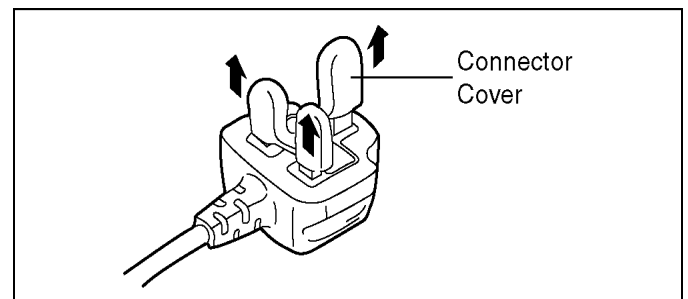

2.3.2.3. How to Replace the Fuse

1. Remove the Fuse Cover with a screwdriver.

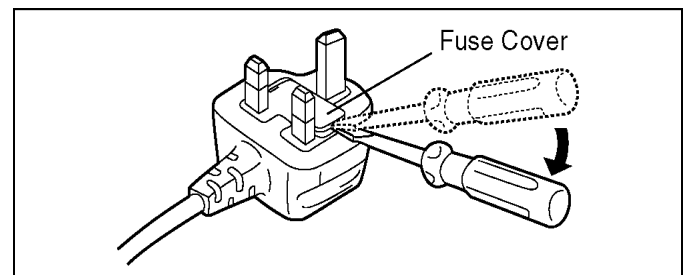

2. Replace the fuse and attach the Fuse cover.

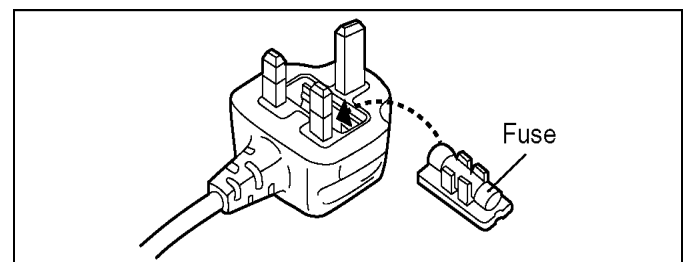

2.4. How to Replace the Lithium Battery

2.4.1. Replacement Procedure

1. Remove the SD HOLDER P.C.B.. (Refer to Disassembly Procedures.)
2. Remove the Lithium battery (Ref. No. "B6401" at foil side of SD HOLDER P.C.B.) and then replace it into new one.

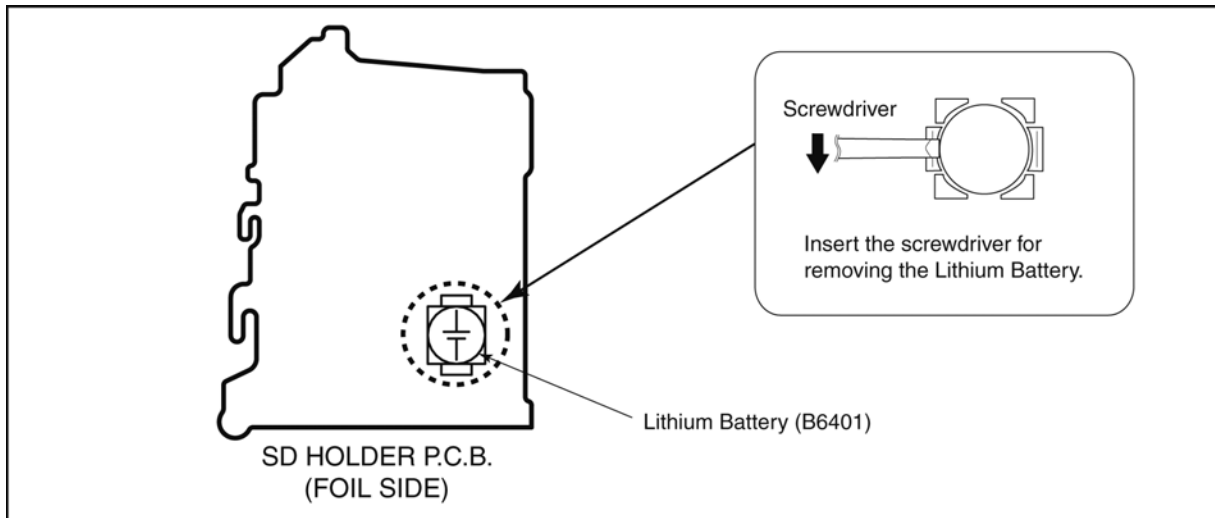

NOTE:

This Lithium battery is a critical component.

(Type No.: ML-614S/ZTK **Manufactured by Energy Company, Panasonic Corporation**)

It must never be subjected to excessive heat or discharge.

It must therefore only be fitted in requirement designed specifically for its use.

Replacement batteries must be of same type and manufacture.

They must be fitted in the same manner and location as the original battery, with the correct polarity contacts observed.

Do not attempt to re-charge the old battery or re-use it for any other purpose.

It should be disposed of in waste products destined for burial rather than incineration.

(For English)

CAUTION

Danger of explosion if battery is incorrectly replaced.

Replace only with the same or equivalent type recommended by the manufacturer.

Dispose of used batteries according to the manufacturer's instructions.

(For German)

ACHTUNG

Explosionsgefahr bei falschem Anbringen der Batterie. Ersetzen Sie nur mit einem äquivalentem vom Hersteller empfohlenem Typ.

Behandeln Sie gebrauchte Batterien nach den Anweisungen des Herstellers.

(For French)

MISE EN GARDE

Une batterie de remplacement inappropriée peut exploser. Ne remplacez qu'avec une batterie identique ou d'un type recommandé par le fabricant. L'élimination des batteries usées doit être faite conformément aux instructions du fabricant.

NOTE:

Above caution is applicable for a battery pack which is for HDC-HS80 series, as well.

1. Battery Pack for this model.

3 Service Navigation

3.1. Introduction

This service manual contains technical information, which allow service personnel's to understand and service this model. Please place orders using the parts list and not the drawing reference numbers. If the circuit is changed or modified, the information will be followed by service manual to be controlled with original service manual.

3.2. General Description About Lead Free Solder (PbF)

The lead free solder has been used in the mounting process of all electrical components on the printed circuit boards used for this equipment in considering the globally environmental conservation.

The normal solder is the alloy of tin (Sn) and lead (Pb). On the other hand, the lead free solder is the alloy mainly consists of tin (Sn), silver (Ag) and Copper (Cu), and the melting point of the lead free solder is higher approx.30°C (86°F) more than that of the normal solder.

Distinction of P.C.B. Lead Free Solder being used

| | |
|--|-----|
| The letter of "PbF" is printed either foil side or components side on the P.C.B. using the lead free solder.(See right figure) | PbF |
|--|-----|

Service caution for repair work using Lead Free Solder (PbF)

- The lead free solder has to be used when repairing the equipment for which the lead free solder is used. (Definition: The letter of "PbF" is printed on the P.C.B. using the lead free solder.)
- To put lead free solder, it should be well molten and mixed with the original lead free solder.
- Remove the remaining lead free solder on the P.C.B. cleanly for soldering of the new IC.
- Since the melting point of the lead free solder is higher than that of the normal lead solder, it takes the longer time to melt the lead free solder.
- Use the soldering iron (more than 70W) equipped with the temperature control after setting the temperature at 350±30°C (662±86°F).

Recommended Lead Free Solder (Service Parts Route.)

- The following 3 types of lead free solder are available through the service parts route.
 - RFKZ03D01KS----- (0.3mm 100g Reel)
 - RFKZ06D01KS----- (0.6mm 100g Reel)
 - RFKZ10D01KS----- (1.0mm 100g Reel)

Note

* Ingredient: tin (Sn) 96.5%, silver (Ag) 3.0%, Copper (Cu) 0.5%, Cobalt (Co) / Germanium (Ge) 0.1 to 0.3%

3.3. Important Notice 1:(Other than U.S.A. and Canadian Market)

1. The service manual does not contain the following information, because of the impossibility of servicing at component level without concerned equipment/facilities.
 - a. Schematic diagram, Block Diagram and P.C.B. layout of MAIN P.C.B..
 - b. Parts list for individual parts for MAIN P.C.B..When a part replacement is required for repairing MAIN P.C.B., replace as an assembled parts. (Main P.C.B.)
2. The following category is /are recycle module part. Please send it/them to Central Repair Center.
 - MAIN P.C.B. (VEP03J12CN: HDC-HS80P/PC/PU/GT)
 - MAIN P.C.B. (VEP03J12CP: HDC-HS80EB/EC/EG/EP)
 - MAIN P.C.B. (VEP03J12CQ: HDC-HS80EE/GA/GC/GK/GN)

3.4. How to Define the Model Suffix (NTSC or PAL model)







There are seven kinds of HDC-HS80.

- a) HDC-HS80P
- b) HDC-HS80PC
- c) HDC-HS80EB/EC/EG/EP/GN
- d) HDC-HS80EE
- e) HDC-HS80GK
- f) HDC-HS80GT
- g) HDC-HS80GA/GC/PU

What is the difference is that the "INITIAL SETTING" data which is stored in Flash ROM mounted on Main P.C.B..

3.4.1. Defining methods:

To define the model suffix to be serviced, refer to the rating label and caution label which are putted on the Unit.

| |
|---|
| <p>a) HDC-HS80P The nameplate for this model shows the following Safety registration mark.</p>  |
| <p>b) HDC-HS80PC The nameplate for this model shows the following Safety registration mark.</p>  |
| <p>c) HDC-HS80EB/EC/EG/EP/GN The nameplate for these models show the following Safety registration mark.</p>  |
| <p>d) HDC-HS80EE The nameplate for this model shows the following Safety registration mark.</p>  |
| <p>e) HDC-HS80GK The nameplate for this model shows the following Safety registration mark.</p>  |
| <p>f) HDC-HS80GT The nameplate for this model shows the following Safety registration mark.</p>  |
| <p>g) HDC-HS80GA/GC/PU The nameplate for these models show the following Safety registration mark.</p> |

NOTE:



After replacing the MAIN P.C.B., be sure to achieve adjustment.

The adjustment instruction is available at "software download" on the "Support Information from NWBG/VDBG-AVC" web-site in "TSN system", together with Maintenance software.

3.5. Precautions for Handling HDD

1. Handle HDD very carefully to prevent the static electricity and shock.
2. Set the HDD quickly after taking it out from the package. Make sure to put the HDD on buffer materials, etc.

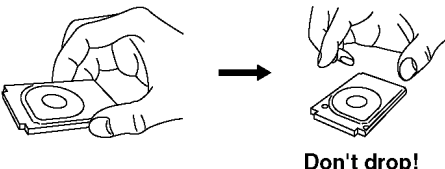
3.5.1. Precautions at incoming process and for opening packages

| | |
|-------------------------------|---|
| Preventing shock | <ul style="list-style-type: none"> ▪ Do not throw down HDD from luggage carrier or avoid dropping accidentally when unloading. The HDD may not be reliable when impacts of dropping, throwing or rolling occur. ▪ Avoid HDD hitting other equipment or other HDD. Hold HDD firmly but do not apply excessive force when taking out from the package because it is particularly slippery. ▪ When taking out HDD from the package, make sure to put buffer materials such as conductive urethane materials on a work table. Also, a stable place is recommended to avoid impacts or vibration. |
| Preventing condensation | <ul style="list-style-type: none"> ▪ To prevent dew condensation on HDD due to sharp temperature change, keep it indoors without unpacking, and adjust the package of HDD to room temperature completely before unpacking. ▪ Avoid entrance or window areas where temperature changes easily for storage. |
| Holding example | <ul style="list-style-type: none"> ▪ Take out HDD holding both sides, not to press the top cover and the center of the device label. <div style="text-align: center;"> <p><OK></p>  <p>Don't drop!</p> </div> <div style="text-align: center;"> <p><NG></p>  </div> |
| Preventing static electricity | <ul style="list-style-type: none"> ▪ After opening package, HDD must be handled only by a specified worker in E.S.D.* free environment on a conductive mat. It may cause damage on HDD components due to overvoltage such as electrostatic discharge, etc. |

*E.S.D. = Electrostatically Sensitive Devices

3.5.2. Precautions for installing HDD

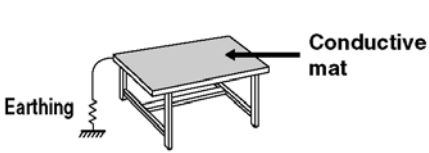
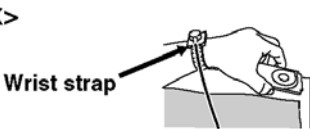
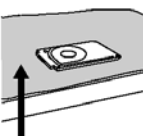
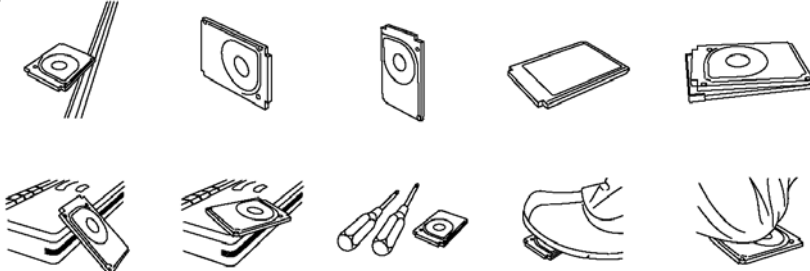
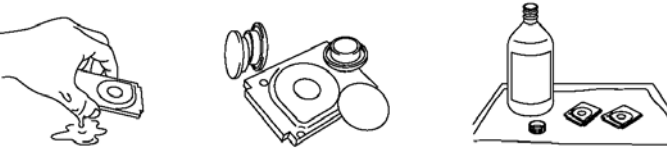
| | |
|--------------------------------------|---|
| <p>Preventing static electricity</p> | <ul style="list-style-type: none"> HDD may be destroyed by static electricity charged to clothes or human body. Place a conductive mat with removed earthing and use the wrist strap to prevent static charge. <p><OK></p>  <p>Conductive mat</p> <p>Earthing</p> <p><OK></p>  <p>Wrist strap</p> |
| <p>Preventing shock</p> | <ul style="list-style-type: none"> Place HDD with its face upward (the device label upward) on the flat and stable surface using buffer materials, etc. Do not stand HDD. If it falls down, the excessive impacts may damage HDD. Do not store or carry HDD close to other HDD or other components. The components may be distorted due to impacts or weight, which may result in the performance deterioration of the HDD. Do not put HDD in the working area. Do not put HDD close to industrial tools in particular or temporarily put it on the floor. Be extremely careful not to drop HDD when working on it because even dropping HDD down on the work table with a mat on it may cause damage to HDD. <p><OK></p>  <p>Buffer materials</p> <p><NG></p>  |
| <p>No water / solvent</p> | <ul style="list-style-type: none"> Do not hold HDD with a wet hand or put magnets, solvent, tea, coffee, etc. close to HDD. This affects internal components and outside of HDD. <p><NG></p>  |
| <p>Connector</p> | <ul style="list-style-type: none"> The interface connector pin is easily damaged. Push it lightly and firmly to the end along the connector guide. For further details, refer to "Precautions for inserting and removing HDD FPC". |

3.5.3. Precautions for inserting and removing HDD FPC

Make sure to use the tool (LSVQ0112) when locking and unlocking the lock lever of HDD FPC connector. Do not lock the lock lever without inserting HDD FPC. Otherwise, the connector may be damaged.

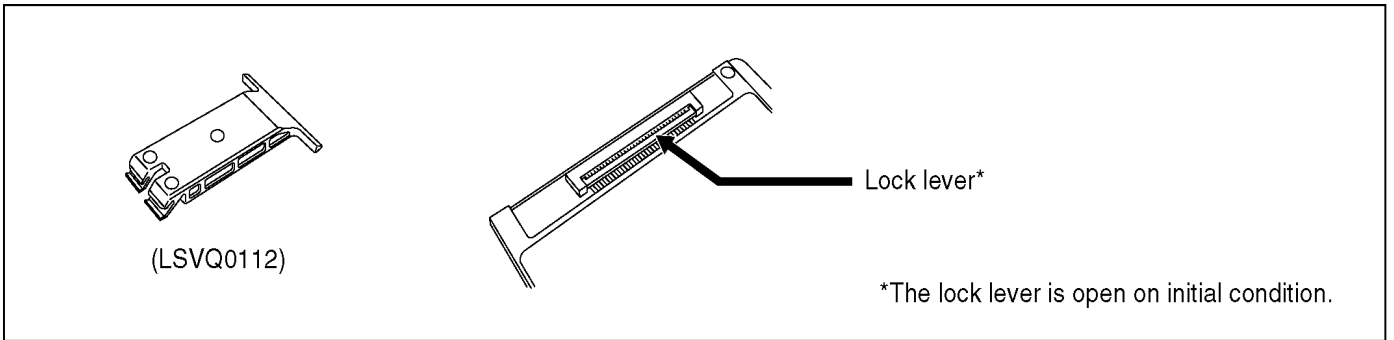

Insert HDD FPC

- ① Place HDD so that HDD device label (CAUTION label) faces up.
Caution: Do not set the HDD cushion when installing HDD FPC.
- ② Insert HDD FPC straight to the connector, and make sure if HDD FPC has been inserted to the end.
Caution: The connector surface of HDD FPC must face down and the letter "HDD" and the arrow must be seen as shown.

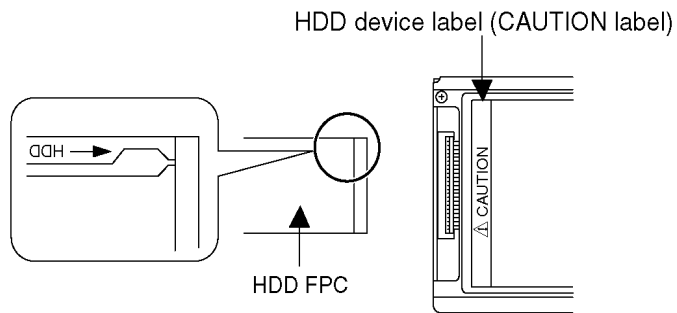

Check HDD FPC

Make sure if HDD FPC has been correctly inserted by confirming the FPC pattern boundary line.

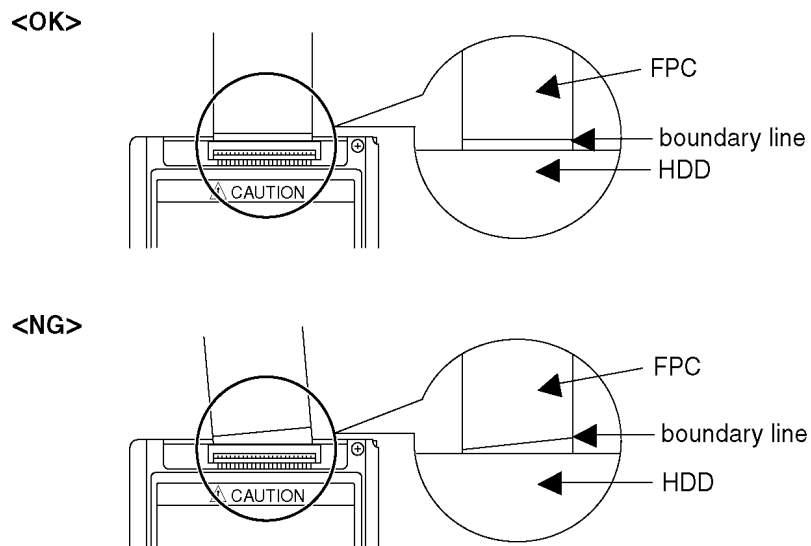

Tool operation

Lock using the tool after inserting HDD FPC.

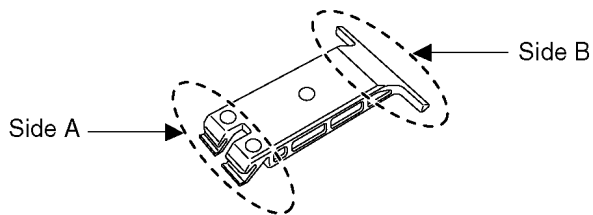

<How to lock>

After inserting HDD FPC, put the tool (Side B) on the connector and slide it slightly to the direction as shown to lock the lock lever.

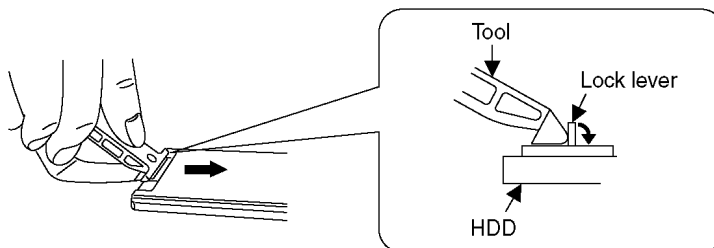

<How to unlock>

Hook up the tip of the tool (Side A) and unlock the lock lever.
The angle of the tool must be less than 45 degree.

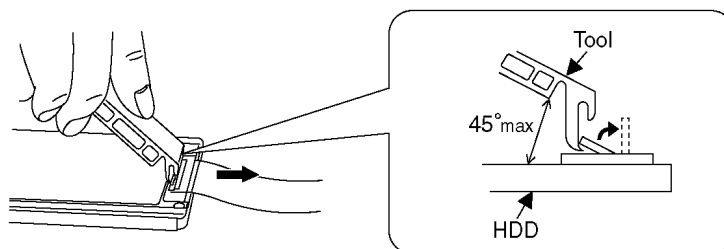

Make sure to use the tool (LSVQ0112) when opening and closing the lock lever.
When install the HDD to main unit, necessary install the HDD FPC and HDD cushion.

3.6. Formatting

[FORMAT MEDIA]

Please be aware that if a medium is formatted, then all the data recorded on the medium will be erased and cannot be restored. Back up important data on a PC, DVD disc etc.

- 1 Touch [FORMAT MEDIA].
- 2 Touch [SD CARD] or [HDD].

- When formatting is complete, touch [EXIT] to exit the message screen.
- Perform a physical formatting of the SD card when the SD card is to be disposed/transferred.
- Perform a physical formatting of the HDD when this unit is to be disposed/transferred.

- Do not turn this unit off or remove the SD card, while formatting. Do not expose the unit to vibrations or shock.

Use this unit to format media.

Formatting HDD is only available with this unit.

Do not format an SD card using any other equipment such as a PC. The card may not be used on this unit.

When disposing of or giving away the SD card, note that:

- Formatting and deletion of this unit or computer only changes the file management information and does not completely delete the data in the SD card.
- It is recommended that the SD card is physically destroyed or the SD card is physically formatted using this unit when disposing of or giving away the SD card.

To physically format the SD card, connect the unit via the AC adaptor, select [SETUP] → [FORMAT MEDIA] → [SD CARD] from the menu, and then press and hold the recording start/stop button on the screen below for about 3 seconds. When the SD card data deletion screen appears, select [YES], and then follow the on-screen instructions.

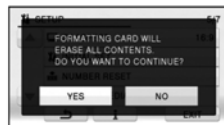

- The customer is responsible for the management of the data in the SD card.

When you are not going to use the unit for an extended time

- When storing the unit in a cupboard or cabinet, it is recommended that you place a desiccant (silica gel) in with it.

When disposing of or giving away this unit, note that:

- Formatting and deletion simply change the file management information and cannot be used to completely erase the data in HDD of this unit. The data can be recovered using commercially available software or the like.
- We recommend that you physically format the HDD before disposing of or giving away this unit.

To physically format the HDD, connect the unit via the AC adaptor, select [SETUP] → [FORMAT MEDIA] → [HDD] from the menu, and then press and hold the recording start/stop button on the screen below for about 3 seconds. When the HDD data deletion screen appears, select [YES], and then follow the on-screen instructions:

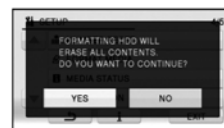

- Please look after the data in your HDD carefully. Panasonic will not be held responsible in the unlikely case that private data is divulged.

4 Specifications

High Definition Video Camera

Information for your safety

| | | |
|---------------------------|---|--------------------|
| Power source: | DC 5.0 V (When using AC adaptor) DC 3.6 V (When using battery) | |
| Power consumption: | Recording: 5.4 W | Charging: 7.7 W |

Signal system:

1080/60i, 540/30p (NTSC areas)
1080/50i, 540/25p (PAL areas)

Recording format:

[HA]/[HG]/[HX]/[HE]; AVCHD format compliant
[iFrame]; MPEG-4 AVC file format compliant (.MP4)

Image sensor:

1/5.8" 1MOS image sensor
Total; 1500 K

Effective pixels:

Motion picture; 1300 K to 1120 K (16:9)
Still picture; 970 K (4:3), 1100 K (3:2), 1300 K to 1120 K (16:9)

Lens: Auto Iris, 34× Optical Zoom, F1.8 to F4.0

Focal length; 2.38 mm to 81 mm

Macro (Full range AF)

35 mm equivalent;

Motion picture; 33.7 mm to 1240 mm (16:9)
Still picture; 41.3 mm to 1405 mm (4:3), 38.1 mm to 1298 mm (3:2), 33.7 mm to 1240 mm (16:9)

Minimum focus distance;

Normal; Approx. 3 cm (1.2") (Wide)/Approx. 1.6 m (5.3 feet) (Tele)
Tele macro; Approx. 70 cm (28") (Tele)

Intelligent auto Macro; Approx. 1 cm (0.4") (Wide)/Approx. 70 cm (28") (Tele)

Zoom:

i.Zoom OFF 37×, 42× i.Zoom, 90×/2000× Digital Zoom
(Using image sensor effective area)

Image stabilizer function:

Optical (Hybrid Optical Image Stabilizer, Active Mode, Optical Image Stabilizer Lock Function)

Monitor:

2.7" wide LCD monitor (Approx. 230 K dots)

Microphone:

Stereo (with a zoom microphone)

Speaker:

1 round speaker, dynamic type

White balance adjustment:

Auto tracking white balance system

Standard illumination:

1,400 lx

Minimum required illumination:

Approx. 7 lx (1/30 with Low light mode in the Scene mode) (NTSC areas)
Approx. 1 lx with the Color Night Rec function (NTSC areas)
Approx. 7 lx (1/25 with Low light mode in the Scene mode) (PAL areas)
Approx. 1 lx with the colour night view function (PAL areas)

AV multi connector video output level:

Component video output level;

Y; 1.0 Vp-p, 75 Ω, Pb; 0.7 Vp-p, 75 Ω, Pr; 0.7 Vp-p, 75 Ω

AV video output level;

1.0 Vp-p, 75 Ω, NTSC system (NTSC areas)
1.0 Vp-p, 75 Ω, PAL system (PAL areas)

HDMI mini connector video output level:

HDMI™ (x.v.Color™) 1080i/480p (NTSC areas)

HDMI™ (x.v.Colour™) 1080i/576p (PAL areas)

AV multi connector audio output level (Line):

316 mV, 600 Ω, 2 ch

HDMI mini connector audio output level:

AVCHD; Dolby Digital/Linear PCM

iFrame; Linear PCM

USB:

Reader/writer function

SD card; Read only (No copyright protection support) (EB/EF/EG/EP areas)

SD card; Read/Write (No copyright protection support) (Other areas)

HDD; Read only

Hi-Speed USB (USB 2.0), USB terminal Type Mini AB

USB host function (for DVD burner)

Battery charging function (Charges from USB terminal when the main unit is off)

Photo light:

Available range; Approx. 1.2 m (3.9 feet)

Dimensions:

60.0 mm (W)×64.0 mm (H)×109 mm (D)

[2.37" (W)×2.51" (H)×4.29" (D)] (excluding projecting parts)

Mass (Weight):

Approx. 265 g (Approx. 0.58 lbs.)

[without battery (supplied)]

Mass (Weight) in operation:

Approx. 307 g (Approx. 0.68 lbs.)

[with battery (supplied)]

Operating temperature:

0 °C to 40 °C (32 °F to 104 °F)

Operating humidity:

10%RH to 80%RH

Battery operation time:

See "Charging and recording time"

■ Motion pictures

Recording media:

SD Memory Card (FAT12 and FAT16 system compliant)

SDHC Memory Card (FAT32 system compliant)

SDXC Memory Card (exFAT system compliant)

Refer to page "Recording to a card" for details on SD cards usable in this unit.

HDD; 120 GB

Compression:

MPEG-4 AVC/H.264

Recording mode and transfer rate:

[HA]; Approx. 17 Mbps (VBR)

[HG]; Approx. 13 Mbps (VBR)

[HX]; Approx. 9 Mbps (VBR)

[HE]; Approx. 5 Mbps (VBR)

[iFrame]; Approx. 28 Mbps (VBR)

Refer to "Recording modes/approximate recordable time" for the recordable time.

Picture size:

[HA]/[HG]/[HX]/[HE]; 1920×1080/60i (NTSC areas)

[iFrame]; 960×540/30p (NTSC areas)

[HA]/[HG]/[HX]/[HE]; 1920×1080/50i (PAL areas)

[iFrame]; 960×540/25p (PAL areas)

Audio compression:

AVCHD; Dolby Digital (2 ch)

iFrame; AAC (2 ch)

■ Still pictures

Recording media:

SD Memory Card (FAT12 and FAT16 system compliant)

SDHC Memory Card (FAT32 system compliant)

SDXC Memory Card (exFAT system compliant)

Refer to "Recording to a card" for details on SD cards usable in this unit.

HDD; 120 GB

Compression:

JPEG (Design rule for Camera File system, based on Exif 2.2 standard),

DPOF corresponding

Picture size:

Picture aspect [4:3]; 1856×1392/640×480

Picture aspect [3:2]; 2064×1376

Picture aspect [16:9]; 2304×1296/1920×1080

Refer to "Approximate number of recordable pictures" for the number of recordable pictures.

AC adaptor

Information for your safety

| | |
|---------------------------|-----------------------------|
| Power source: | AC 110 V to 240 V, 50/60 Hz |
| Power consumption: | 12 W |
| DC output: | DC 5.0 V, 1.6 A |

Dimensions:

46 mm (W)×25 mm (H)×75.5 mm (D) [1.8" (W)×1.0" (H)×3.0" (D)]

Mass (Weight):

Approx. 115 g (Approx. 0.25 lbs.)

Specifications may change without prior notice.

Charging and recording time

Charging/Recording time

- Temperature: 25 °C (77 °F)/humidity: 60%RH
- The stated times are when the AC adaptor is used.

| NTSC areas | | | | | |
|---|---------------|-----------------------|------------------------|--------------------------------------|------------------------|
| Battery model number [Voltage/Capacity (minimum)] | Charging time | Recording destination | Recording mode | Maximum continuously recordable time | Actual recordable time |
| Supplied battery/ VW-VBK180 (optional) [3.6 V/1790 mAh] | 2 h 25 min | HDD | [HA], [HG], [HX], [HE] | 1 h 35 min | 50 min |
| | | | [iFrame] | 1 h 45 min | |
| | | SD | [HA], [HG], [HX], [HE] | 1 h 40 min | 50 min |
| | | | [iFrame] | 1 h 45 min | |
| VW-VBK360 (optional) [3.6 V/3580 mAh] | 4 h 20 min | HDD | [HA], [HG], [HX], [HE] | 3 h 15 min | 1 h 40 min |
| | | | [iFrame] | 3 h 25 min | |
| | | SD | [HA], [HG], [HX], [HE] | 3 h 25 min | 1 h 45 min |
| | | | [iFrame] | 3 h 35 min | |

| PAL areas | | | | | |
|--|------------------|-----------------------|------------------------|--------------------------------------|------------------------|
| Battery model number [Voltage/Capacity (minimum)] | Charging time | Recording destination | Recording mode | Maximum continuously recordable time | Actual recordable time |
| Supplied battery/ VW-VBK180 (optional) [3.6 V/ 1790 mAh] | 2 h 25 min | HDD | [HA], [HG], [HX], [HE] | 1 h 40 min | 50 min |
| | | | [iFrame] | 1 h 45 min | 55 min |
| | | SD | [HA] | 1 h 45 min | 50 min |
| | | | [HG], [HX], [HE] | 1 h 45 min | 55 min |
| VW-VBK360 (optional) [3.6 V/ 3580 mAh] | 4 h 20 min | HDD | [HA] | 3 h 20 min | 1 h 40 min |
| | | | [HG], [HX], [HE] | 3 h 20 min | 1 h 45 min |
| | | SD | [iFrame] | 3 h 35 min | 1 h 50 min |
| | | | [HA] | 3 h 30 min | 1 h 45 min |
| SD | [HG], [HX], [HE] | 3 h 30 min | 1 h 50 min | | |
| | [iFrame] | 3 h 45 min | 1 h 55 min | | |

- These times are approximations.
- The indicated charging time is for when the battery has been discharged completely. Charging time and recordable time vary depending on the usage conditions such as high/low temperature.

Recording to a card

The unit can record still pictures or motion pictures to an SD card or built-in memory. To record to an SD card, read the following.

This unit (an SDXC compatible device) is compatible with SD Memory Cards, SDHC Memory Cards and SDXC Memory Cards. When using an SDHC memory card/SDXC memory card with other equipment, check the equipment is compatible with these memory cards.

Cards that you can use with this unit

Use SD cards conforming to Class 4 or higher of the SD Speed Class Rating* for motion picture recording.

| Card type | Capacity | Motion picture recording | Still picture recording |
|------------------|--|------------------------------------|------------------------------------|
| SD Memory Card | 8 MB/16 MB/ 32 MB | Cannot be used. | Cannot be guaranteed in operation. |
| | 64 MB/128 MB/ 256 MB | Cannot be guaranteed in operation. | |
| SDHC Memory Card | 512 MB/1 GB/ 2 GB | Can be used. | Can be used. |
| | 4 GB/6 GB/8 GB/ 12 GB/16 GB/ 24 GB/32 GB | | |
| SDXC Memory Card | 48 GB/64 GB | | |

* SD Speed Class Rating is the speed standard regarding continuous writing. Check via the label on the card, etc.

e.g.:



Recording modes/approximate recordable time

- SD cards are only mentioned with their main memory size. The stated times are the approximate recordable times for continuous recording.

| Recording mode | Picture size | | | |
|----------------|--------------|-------------|-------------|-------------|
| | [HA] | [HG] | [HX] | [HE] |
| SD card | 4 GB | 30 min | 40 min | 1 h |
| | 16 GB | 2 h | 2 h 40 min | 4 h 10 min |
| | 64 GB | 8 h 30 min | 11 h | 16 h 50 min |
| HDD | 120 GB | 15 h 50 min | 20 h 30 min | 31 h 20 min |

- A Favors image quality
- B Favors recording time

| Recording mode | [iFrame] |
|----------------|----------|
| Picture size | |
| 960×540 | |
| SD card | 4 GB |
| | 16 GB |
| | 64 GB |
| HDD | 120 GB |

- If recording for long periods, prepare batteries for 3 or 4 times the period you wish to record for.
- The default setting is [HG] Mode.
- Maximum continuously recordable time for one scene: 12 hours
- The recording is paused once when the recording time for one scene exceeds 12 hours, and the recording will automatically resume after a few seconds.
- If a recording with a lot of action is recorded, the recording time is reduced.
- The recordable time may be reduced if short scenes are recorded repeatedly.
- Use time indicated in table above the row of 4 GB as a guideline for the time that can be copied onto one DVD disc (4.7 GB).

Approximate number of recordable pictures

- SD cards are only mentioned with their main memory size. The stated number is the approximate number of recordable pictures.

(When [QUALITY] is set to)

| Picture size | | | |
|--------------|--------|-------|--------|
| Aspect ratio | 4:3 | | 3:2 |
| SD card | 4 GB | 2600 | 3000 |
| | 16 GB | 10000 | 12000 |
| | 64 GB | 43000 | 49200 |
| HDD | 120 GB | 86000 | 899100 |

| Picture size | | |
|--------------|--------|-------|
| Aspect ratio | 16:9 | |
| SD card | 4 GB | 2400 |
| | 16 GB | 10000 |
| | 64 GB | 40000 |
| HDD | 120 GB | 75000 |

- When [QUALITY] is set to , the numbers of recordable pictures will take more than the above mentioned.
- The number of recordable pictures depends on whether and are used together and on the subject being recorded.
- Maximum number of recordable pictures that can be displayed is 99999. If the number of recordable pictures exceeds 99999, the number will not change when the picture is taken until the number of recordable pictures gets less than 99999.
- The memory capacity indicated on the label of an SD card is the total of the capacity for copyright protection and management and the capacity which can be used on the unit, a PC etc.

5 Location of Controls and Components

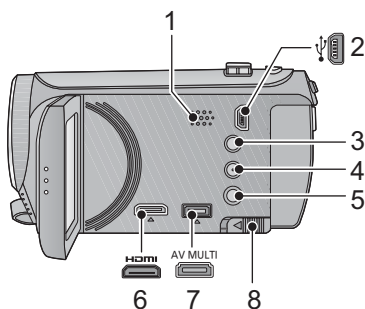

- 1 Speaker
 - 2 USB terminal [⏏]
 - 3 Intelligent auto/Manual button [iA/MANUAL]
 - 4 Optical image stabilizer button [O.I.S.]
 - 5 Power button [⏻/⏺]
 - 6 HDMI mini connector [HDMI]
 - 7 AV multi connector
- Use the AV multi cable (only the supplied cable).
- 8 Battery release lever [BATT]

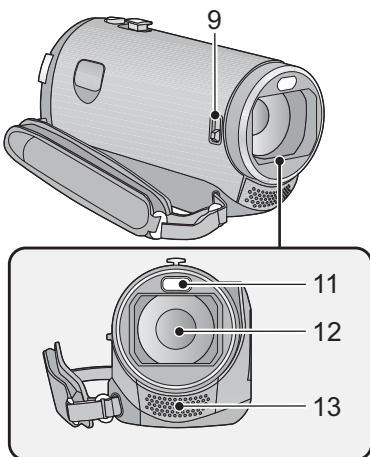

- 9 Lens cover closing switch
- The lens cover will open automatically when set to Motion Picture Recording Mode or Still Picture Recording Mode. When not using the unit, close the lens cover to protect the lens.
- Lens cover does not close automatically.
 - Slide the Lens cover closing switch to close the cover.

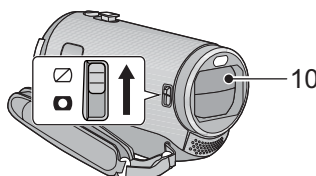

- 10 Lens cover
 - 11 LED light
- It can be used as a Video light or Photo light.
- 12 Lens
 - 13 Internal stereo microphones

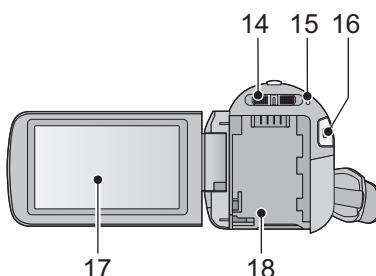

- 14 Mode switch
- 15 Status indicator
- 16 Recording start/stop button
- 17 LCD monitor (Touch screen)



- It can open up to 90°.

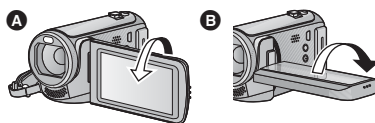

- It can rotate up to 180° **A** towards the lens or 90° **B** towards the opposite direction.

Due to limitations in LCD production technology, there may be some tiny bright or dark spots on the LCD monitor screen. However, this is not a malfunction and does not affect the recorded picture.

- 18 Battery holder

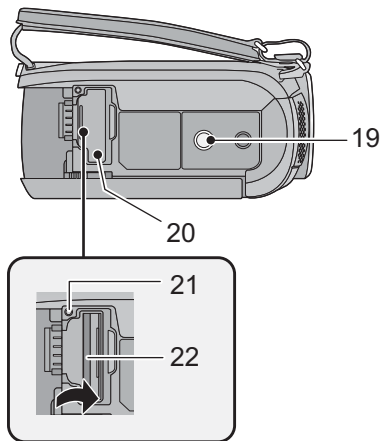

19 Tripod receptacle

- If you attach a tripod which has 5.5 mm (0.22 ") screw or larger, it may damage this unit.

20 SD card cover

21 Access lamp [ACCESS]

22 Card slot

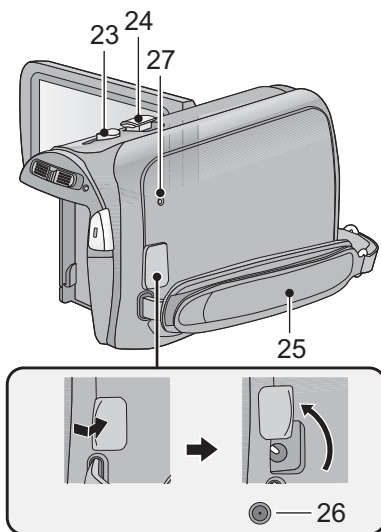

23 Photoshot button []

24 Zoom lever [W/T] (In Motion Picture Recording Mode or Still Picture Recording Mode)

Thumbnail display switch [ / Q] / Volume lever [-VOL+] (In Playback Mode)

25 Grip belt

Adjust the length of the grip belt so that it fits your hand.

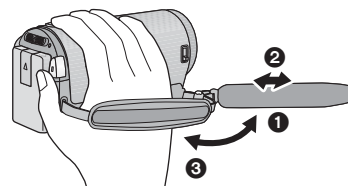

❶ Flip the belt.

❷ Adjust the length.

❸ Replace the belt.

26 DC input terminal [DC IN]

- Do not use any other AC adaptors except the supplied one.



27 HDD access lamp [ACCESS HDD]

Selecting a mode

Change the mode to recording or playback.

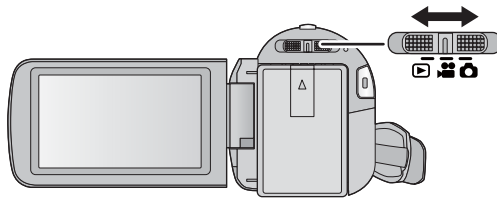
Operate the mode switch to change the mode to ,  or .



| | |
|---|-------------------------------|
|  | Motion picture recording mode |
|  | Still picture recording mode |
|  | Playback mode |

How to use the touch screen

You can operate by directly touching the LCD monitor (touch screen) with your finger. It is easier to use the stylus pen (supplied) for detailed operation or if it is hard to operate with your fingers.

■ Touch

Touch and release the touch screen to select icon or picture.

- Touch the centre of the icon.
- Touching the touch screen will not operate while you are touching another part of the touch screen.

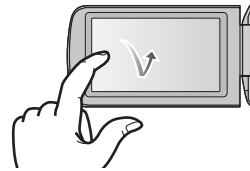

■ Slide while touching

Move your finger while pressing on the touch screen.

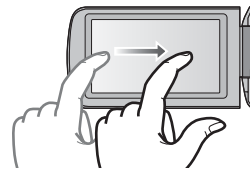

■ About the operation icons

 /  /  /  :

These icons are used to switch the menu and thumbnail display page, for item selection and setting etc.

 :

Touch to return to the previous screen such as when setting menus.



About the Touch Menu

Touch ◀ (left side)/▶ (right side) of  on the Touch Menu to switch the operation icons.

Touch ◀ (left side)/▶ (right side) of  on the Touch Menu.

- It is also possible to switch the operation icons by sliding the Touch Menu right or left while touching it.

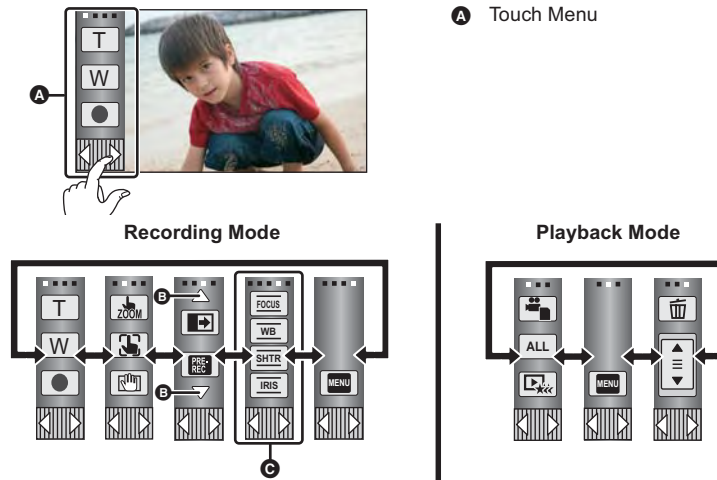

- **B** Touch these icons to switch pages upward or downward.
- **C** Displayed only during the Manual Mode.

■ To display the Touch Menu



The Touch Menu will disappear when no function is performed for a specific period of time during Recording Mode. To display it again, touch .

- Do not touch on the LCD monitor with hard pointed tips, such as ball point pens.
- Perform the touch screen calibration when the touch is not recognized or wrong location is recognized.

6 Service Mode

1. Indication method of the service menu

Set the mode switch "Motion Picture Recording" mode.

- While the power is turned OFF, keep pressing the "Power" button, "Zoom lever" to W side and "intelligent auto/Manual" button for more than 3 seconds until the top screen of the Service Mode Menu being displayed.

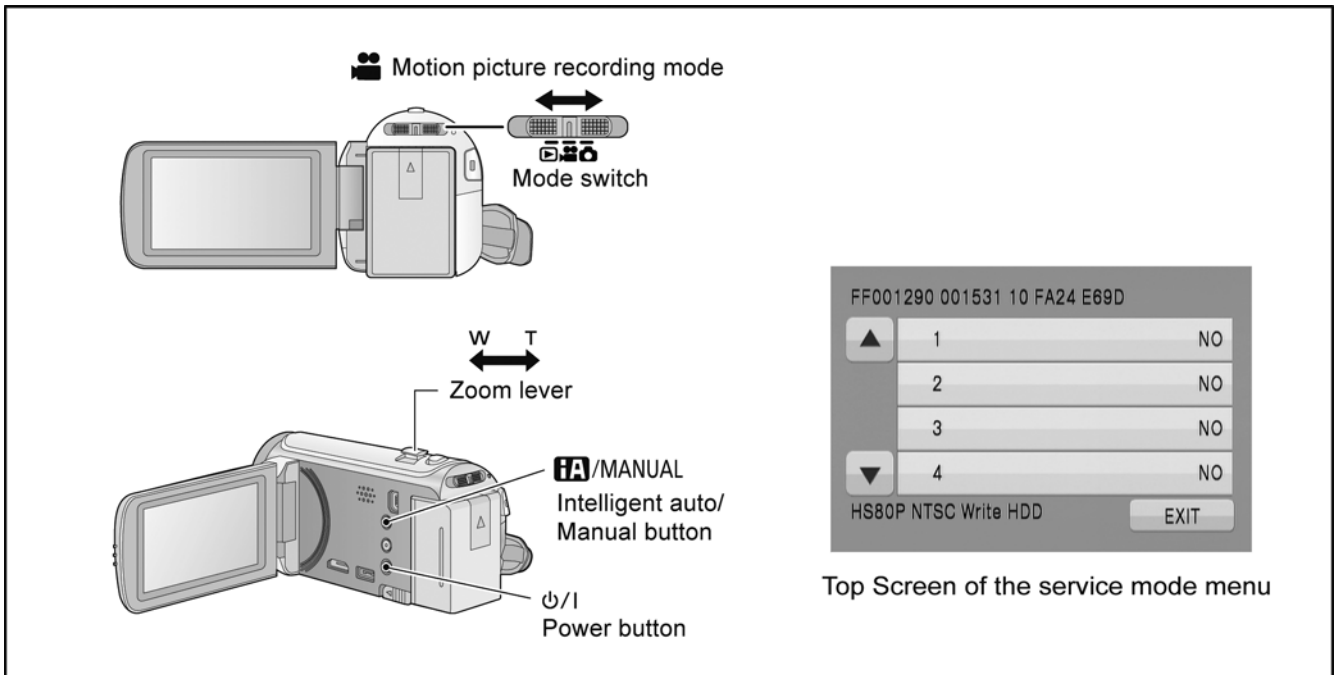

Service mode menu

| Screen display | Contents | Function |
|----------------|---|--|
| 1 | Factory settings | Function to throw a product up in a factory shipment state (When recorded data in HDD, "error display" is done) |
| 2 | Drive information display | Fall detection frequency of HDD, Frequency that exceeds highest/lowest operation guarantee temperature and serial number display |
| 3 | HDD self check execution | Function to check self as for the state of HDD |
| 4 | Lock search history indication | Display the camera system error cord for three histories saved in EEPROM |
| 5 | Power ON self check result display | Power ON self check (function to diagnose correct function of the device and interface between devices) result display |
| 6 | HDD hardware test | Function to confirm state of HDD hardware |
| 10 | Erasing the lock histories | Erasing the error histories (working time is not erased) |
| 11 | Erasing the internal media management information | Erasing the internal media management information for fast boot stored in IC3402(flash memory) |
| 12 | Camera data indications while the video playback | Display the camera informations (Shutter speed, Iris value, White balance and focal length) while playing recorded video |

NOTE:

Do not using service mode except above table of Service mode menu.

- End method of the top screen of the service mode menu

Touch the [EXIT] of LCD to end the service mode, and then POWER OFF.

6.1. Drive Information Display

Touch the [2] of LCD, select Drive Information display.

Operation specifications

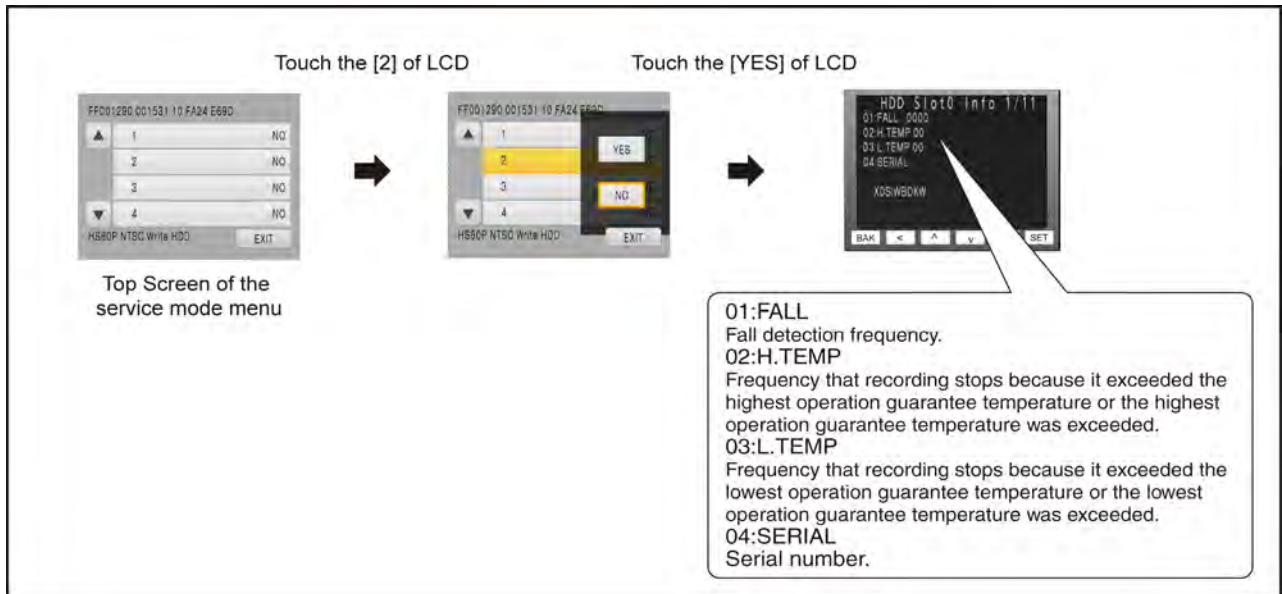

Indication contents

- Drive Information display

Display the fall detection frequency of HDD, Frequency that exceeds highest/lowest operation guarantee temperature and serial number.

Touch the [BAK] of LCD to end the service mode, and then POWER OFF.

6.2. HDD Self Check Execution

Touch the [3] of LCD, select HDD self check execution.

Operation specifications

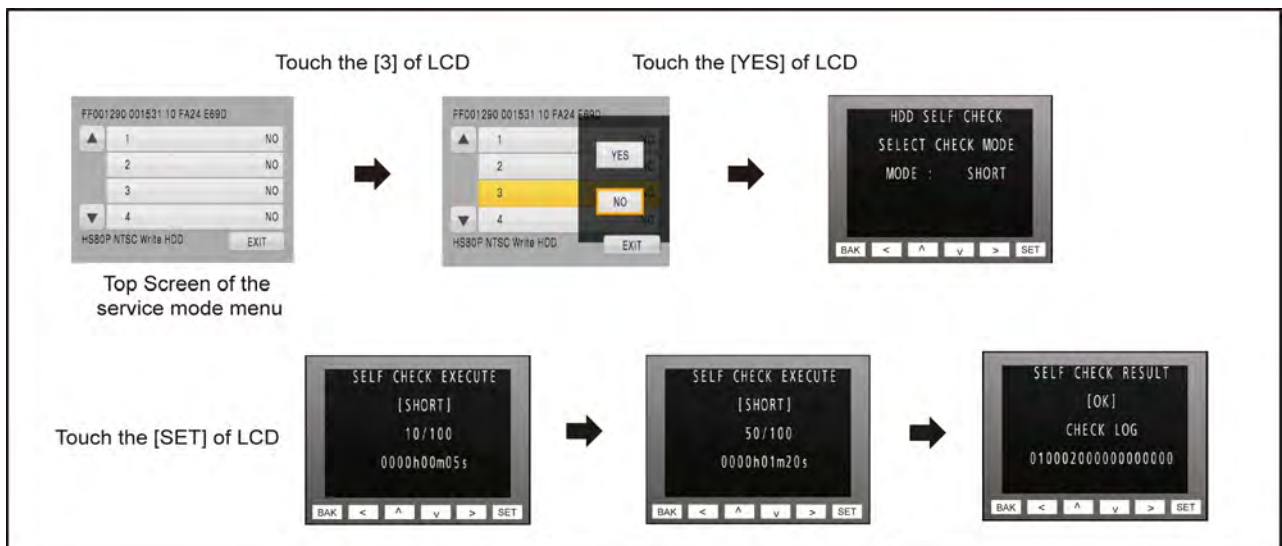

Indication contents

- HDD self check execution

Display the HDD self check result information.

Displays other than “OK” are abnormalities of HDD.

Touch the [BAK] of LCD to end the service mode, and then POWER OFF.

6.3. Lock Search History Indication

Touch the [4] of LCD, select Lock search history indication.

Operation specifications

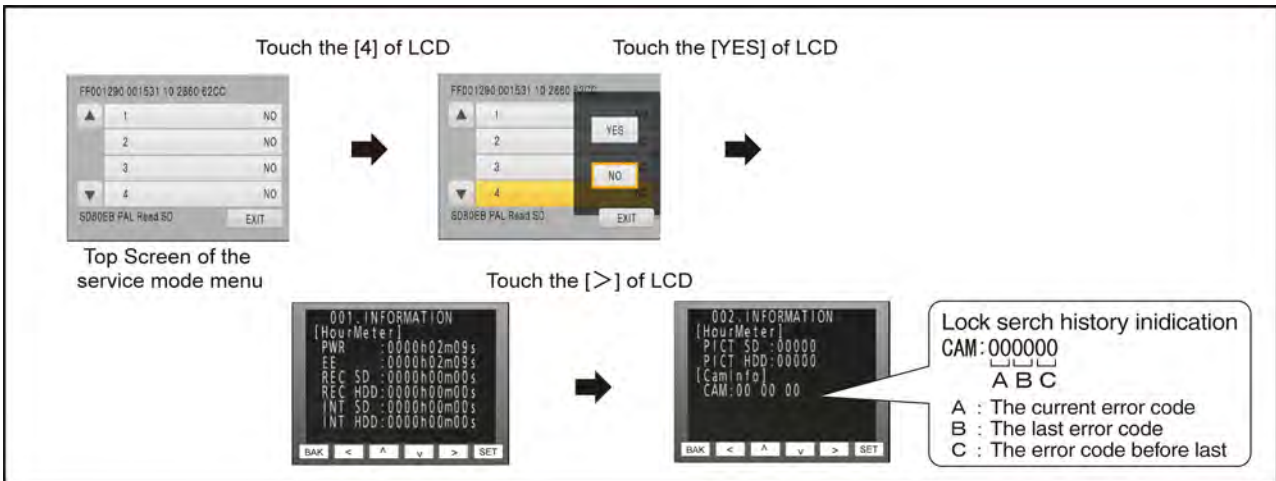

Indication contents

- Lock search history indication
Display the camera system error cord for three histories saved in EEPROM.
- The error cord contents which are displayed

| Error code | Function |
|------------|--|
| 51 | Focus control is abnormal |
| 52 | Zoom control is abnormal |
| 53 | OIS lens control is abnormal |
| 71 | Lens cover open/close is abnormal |
| 73 | High temperature is abnormal |
| 33 | Communication between IC2006 to IC3401 is abnormal |

Cutting of battery connection or AC power supply connection to end the service mode.

6.4. Power ON Self Check Result Display

Touch the [5] of LCD, select Power ON self check result display.

Operation specifications

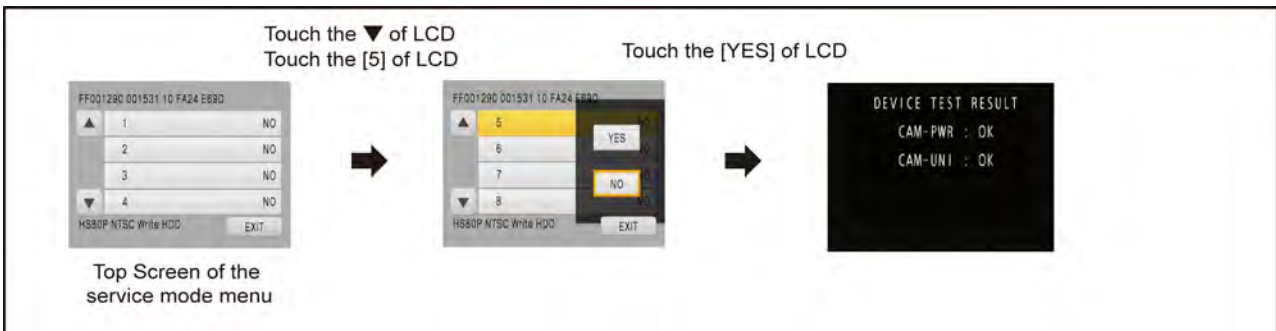

Indication contents

- Power ON self check result display
Function to diagnose correct function of the device and interface between devices result display.

Display the following commnucation test result.

- CAM-PWR : Commnucation test between IC2006 to IC1503
- CAM-UNI : Commnucation test between IC2006 to IC3401

Display other than “OK” are abnormalities of each lines.

Cutting of battery connection or AC power supply connection to end the service mode.

6.5. HDD Hardware Test

Touch the [6] of LCD, select HDD hardware test.

Operation specifications

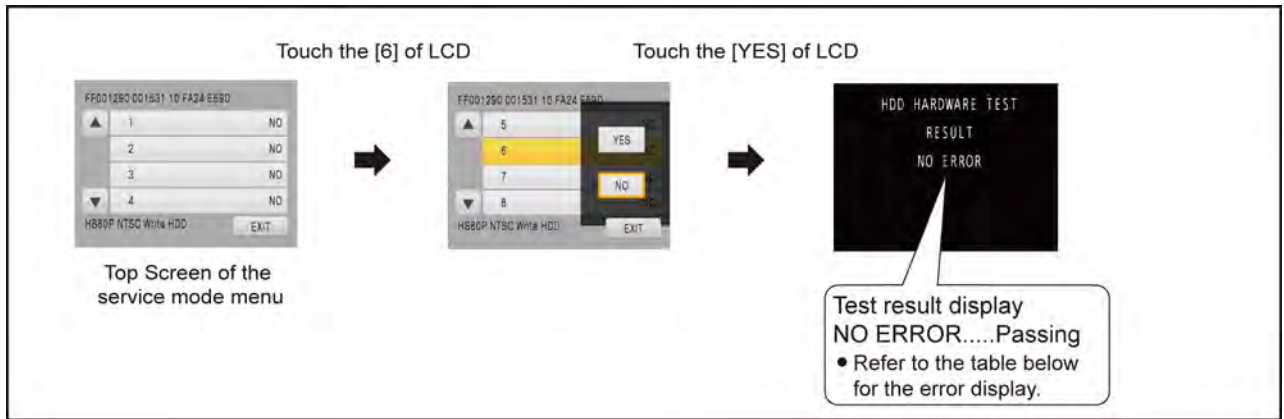

Indication contents

- HDD hardware test
Display the HDD hardware test result information.
- The error cord contents which are displayed

| Error code | Function |
|----------------|--------------------------------|
| NO ERROR | It is normal without the error |
| CTR ERROR | Controller Resistor Error |
| BUFF RAM ERROR | Buffer RAM Error |
| ECC DEV ERROR | ECC device Error |
| CPU ERROR | CPU RAM/ROM Error |
| COMMAND ERROR | Reserved |

In the above table, displays other than “NO ERROR” are abnormalities of HDD.

Cutting of battery connection or AC power supply connection to end the service mode.

6.6. Erasing the lock histories

Touch the [10] of LCD, select erasing the lock histories execution.

Operation specifications

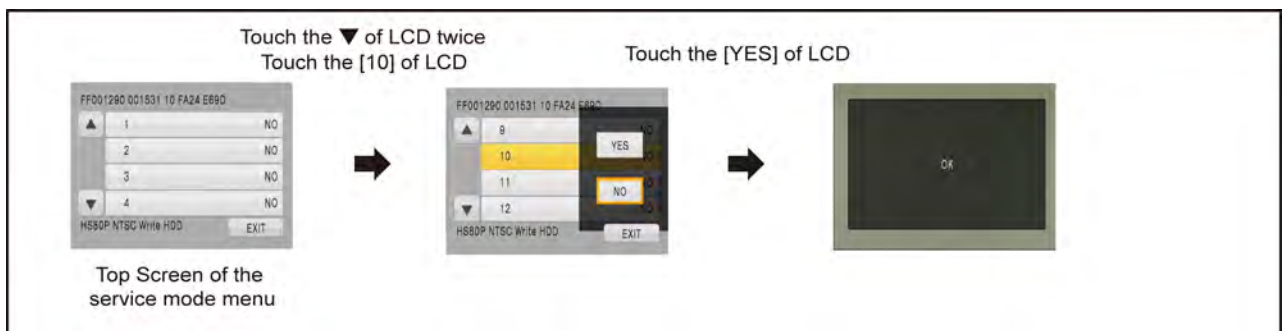

Indication contents

- Erasing the error histories stored in EEPROM. (working time is not erased)

Press the power button and turn off.

6.7. Erasing the internal media management information

Touch the [11] of LCD, select erasing the internal media management information for fast boot stored in flash memory.

Operation specifications

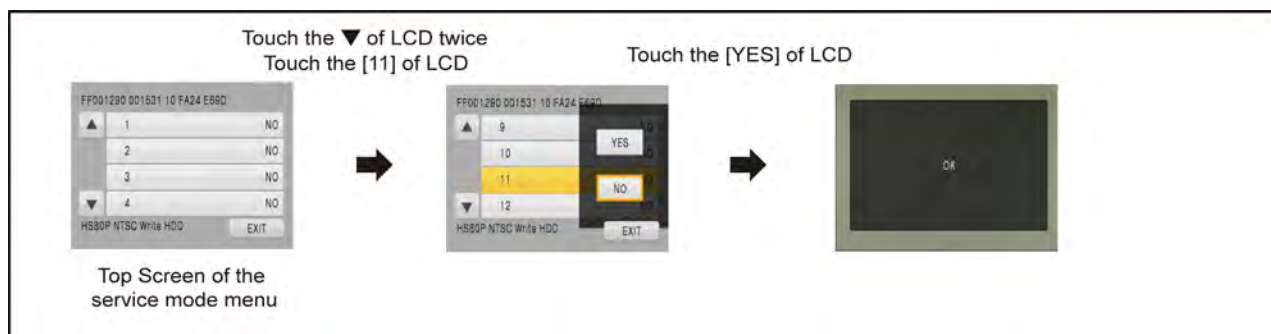

Indication contents

- The fast boot management informations of the internal media are stored in the flash memory. The following cases, be sure to implement for protection of customer's recorded data. However, if there is no problem to delete customer's recorded data, erasing the internal media management information is not required.
- Case1:
When replacing the flash memory chip (IC3402) or replacing the MAIN P.C.B. Unit.
Before checking the operations after replacing the parts, erasing the internal media management information.
- Case2:
When replacing the HDD Unit.
Before replacing the HDD Unit, erasing the internal media management information. then replace it new one.

CAUTION:

When turning the unit on after performing the above operation, the internal media management information is stored into the unit, the playback of the recorded data is normally.

When not performing the above operation, the customer's recorded data will disappear.

Press the power button and turn off.

6.8. Camera data indications while the video playback

Touch the [12] of LCD, select indicating the camera informations while playing back the recorded video.

Operation specifications

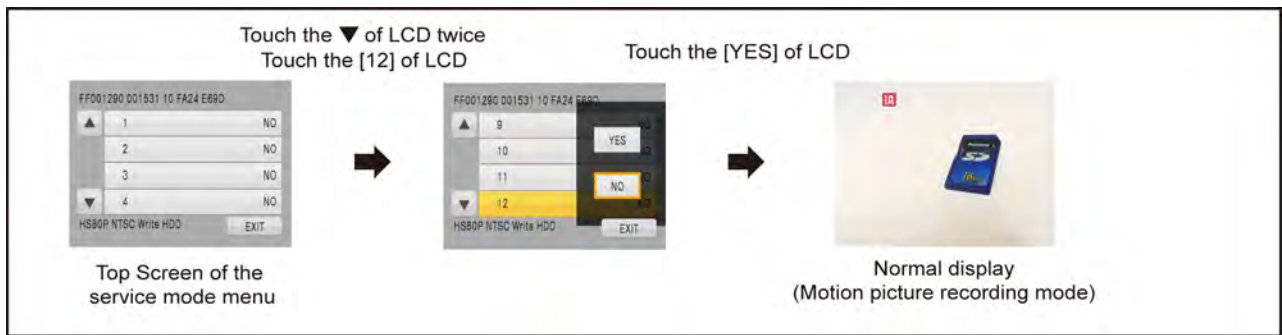

Indication contents

- While playing back the recorded videos, the camera informations (Shutter speed, Iris value, White balance and focal length) are superimposed on the LCD screen.



Press the power button and turn off.

7 Service Fixture & Tools

7.1. When Replacing the Main P.C.B.

After replacing the MAIN P.C.B., be sure to achieve adjustment.

The adjustment instruction is available at "software download" on the "Support Information from NWBG/VDBG-AVC" web-site in "TSN system", together with Maintenance software.

7.2. Service Position

This Service Position is used for checking and replacing parts. Use the following Extension cables for servicing.

Table S1 Extension Cable List

| No. | Parts No. | Connection | Form |
|-----|-----------|--|------------------|
| 1 | RFKZ0448 | FP6001(MAIN) - MONITOR FPC | 33PIN 0.3 FFC |
| 2 | RFKZ0444 | PP6001(MAIN) - PS6401(SD HOLDER) | 50PIN 0.5 B to B |
| 3 | VFK1480 | FP6003(MAIN) - ECM HOLL FPC(FRONT CASE UNIT) | 6PIN 0.5 FFC |
| 4 | VFK1440 | FP6402(SD HOLDER) - TOP OPERATION UNIT(SIDE CASE-R UNIT) | 10PIN 0.5 FFC |
| 5 | RFKZ0379 | PP6006(MAIN) - HDD FPC | 40PIN 0.5 B to B |

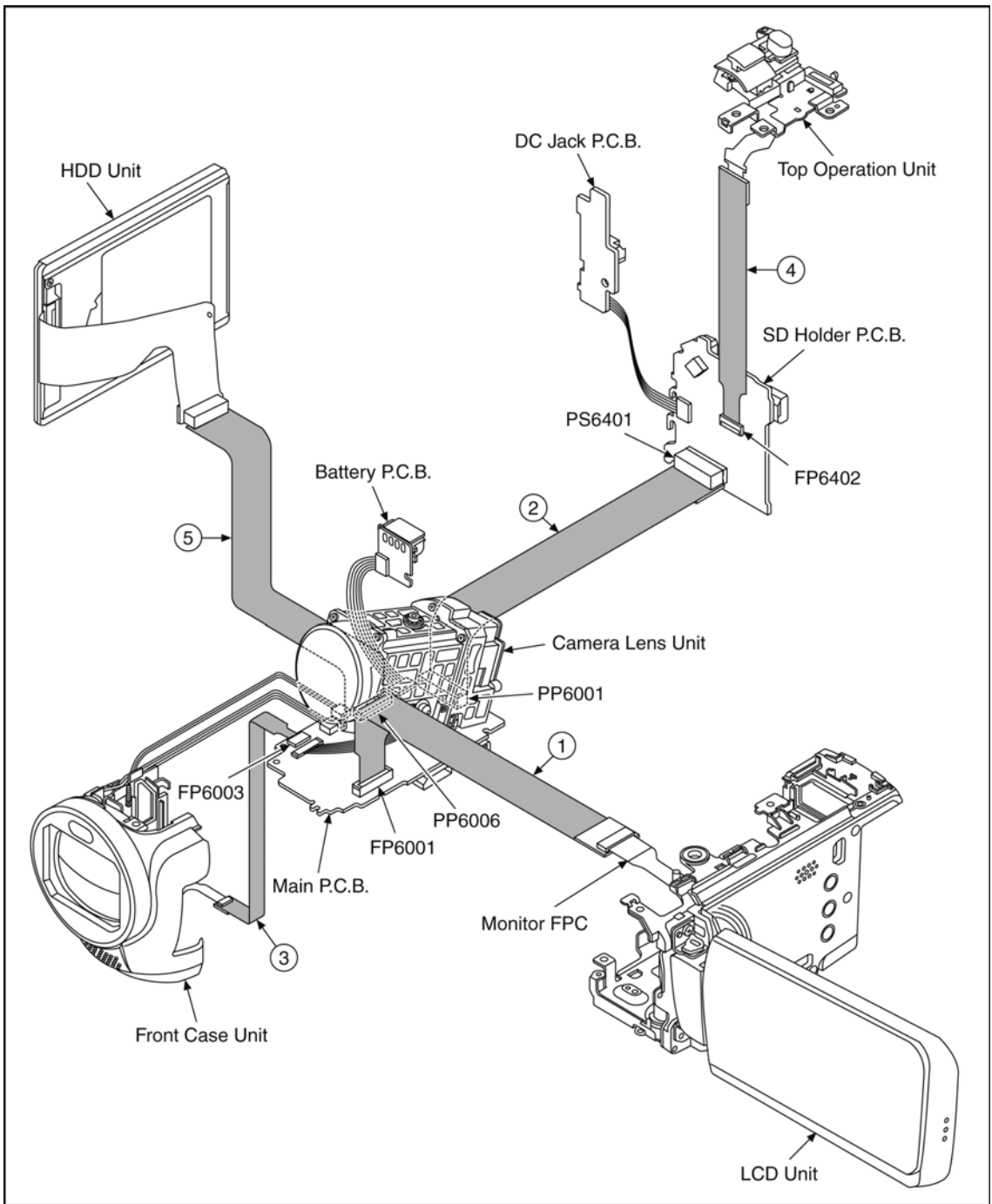

8 Disassembly and Assembly Instructions

8.1. Disassembly Flow Chart for the Unit

This is a disassembling chart.

When assembling, perform this chart conversely.

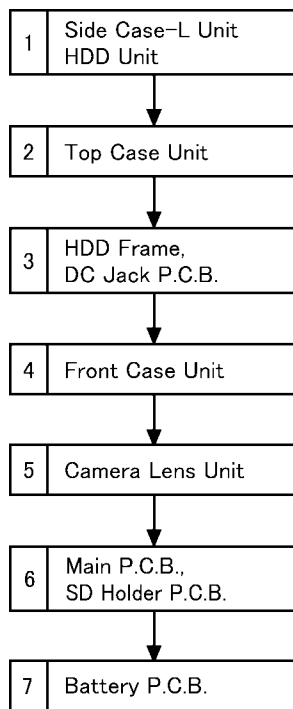

8.2. PCB Location

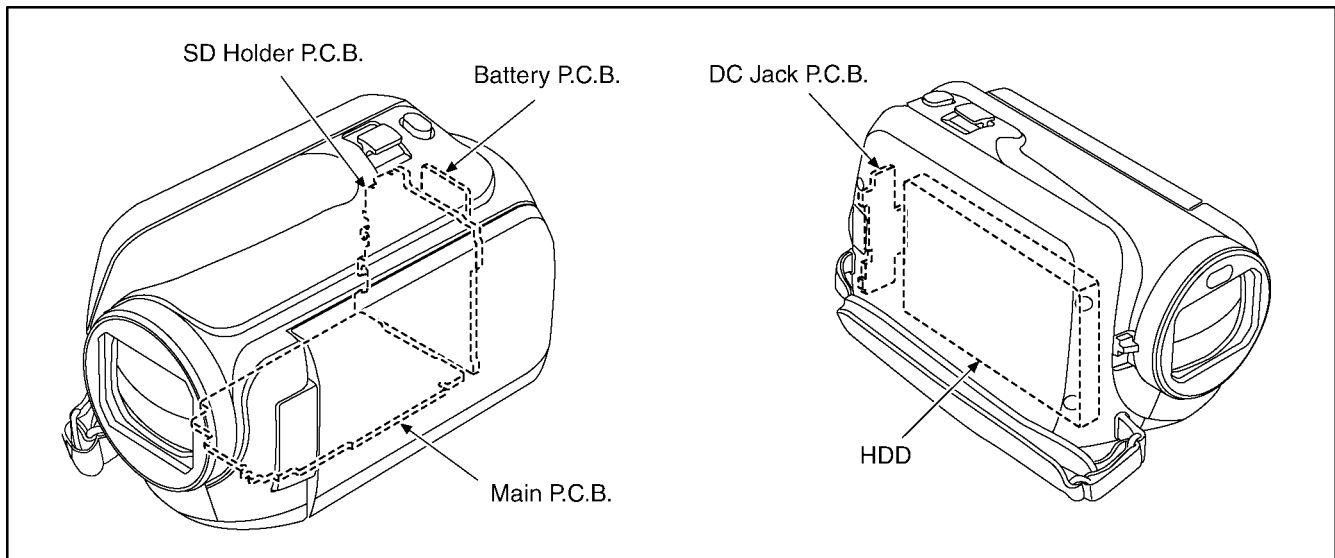

8.3. Disassembly Procedure for the Unit

| No. | Item | Fig | Removal | | | |
|------------------|--|-------------------|-----------------------------|------------|----------------|-------------------|
| 1 | Top Case Unit | (Fig. D1) | 2 Screws (A) | | | |
| | | | 1 Screw (B) | | | |
| | | (Fig. D2) | 3 Screws (C) | | | |
| | | | 4 Locking tabs | | | |
| | | | PP6006(Connector) | | | |
| | | | Closing Lever Base | | | |
| | | | Lens Cover Closing Lever | | | |
| | | (Fig. D3) | 2 HDD Cushions | | | |
| | | | HDD Unit | | | |
| | | | Top Case Unit | | | |
| 2 | Side Case-L Unit | (Fig. D4) | 1 Screw (D) | | | |
| | | | 1 Screw (E) | | | |
| | | (Fig. D5) | 3 Locking tabs | | | |
| | | | 1 Convex | | | |
| | | | 1 Projection part | | | |
| | | (Fig. D5) | Side Case-L Unit | | | |
| | | 3 | HDD Frame DC Jack P.C.B. | (Fig. D6) | 2 Screws (F) | |
| P6751(Connector) | | | | | | |
| (Fig. D7) | 1 Convex | | | | | |
| | 3 Projection parts | | | | | |
| | 1 Locking tab | | | | | |
| | 2 Projection parts | | | | | |
| | 1 Screw (G) | | | | | |
| | HDD Frame | | | | | |
| DC Jack P.C.B. | | | | | | |
| 4 | Front Case Unit | | | (Fig. D8) | 1 Screw (H) | |
| | | 1 Screw (I) | | | | |
| | | FP6003 (Flex) | | | | |
| | | P6002(Connector) | | | | |
| | | P6004 (Connector) | | | | |
| | | 1 Rib | | | | |
| | | Front Case Unit | | | | |
| | | 5 | Camera Lens Unit | | (Fig. D9) | FP6008 (Flex) |
| | | | | | | P6001 (Connector) |
| | | | | | | 1 Convex |
| Camera Lens Unit | | | | | | |
| | | | | | | |
| 6 | Main P.C.B. SD Holder P.C.B. | (Fig. D10) | 5 Screws (J) | | | |
| | | | P6003 (Connector) | | | |
| | | | P6401 (Connector) | | | |
| | | | FP6001 (Flex) | | | |
| | | | FP6402 (Flex) | | | |
| | | | 2 Ribs | | | |
| | | | SD Holder P.C.B. | | | |
| | | Main P.C.B. | | | | |
| | | (Fig. D11) | NOTE: (When Installing) | | | |
| | | 7 | Battery P.C.B. | (Fig. D12) | 2 Locking tabs | |
| 1 Hanging part | | | | | | |
| (Fig. D13) | 1 Screw (K) | | | | | |
| | 3 Ribs | | | | | |
| | S/S Lever Angle S/S Lever Battery P.C.B. | | | | | |

NOTE:
When servicing and reassembling, remove the card and battery pack from the unit.

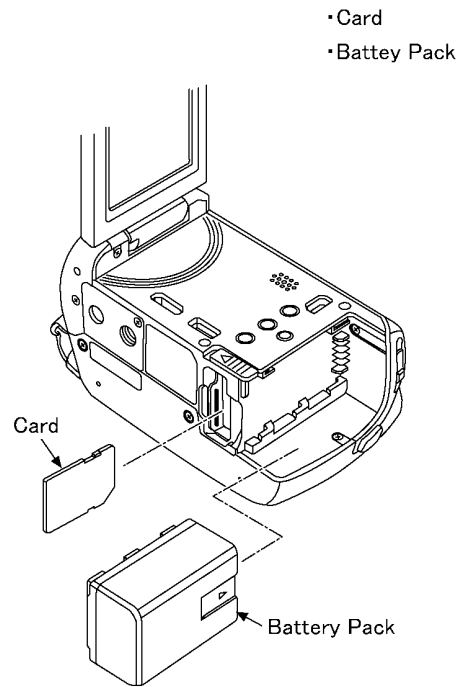

8.3.1. Removal of the Side Case-L Unit and HDD Unit

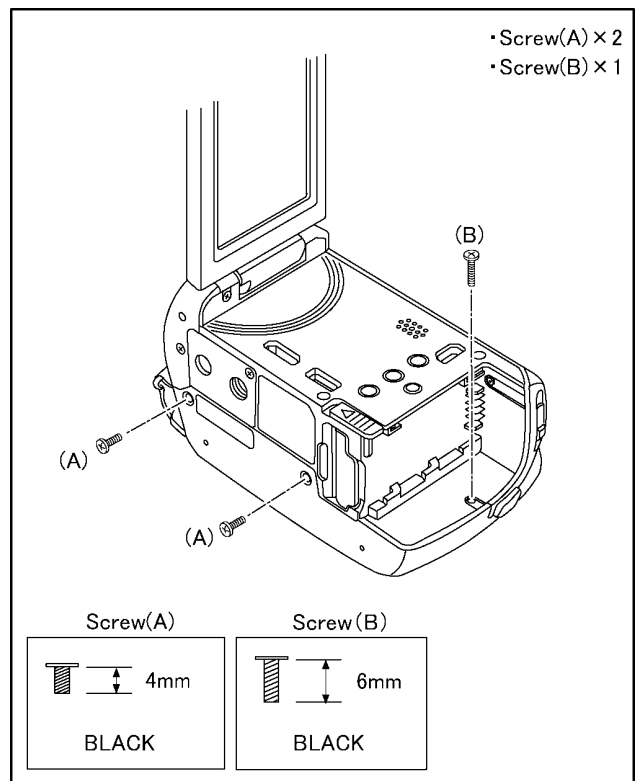

(Fig. D1)

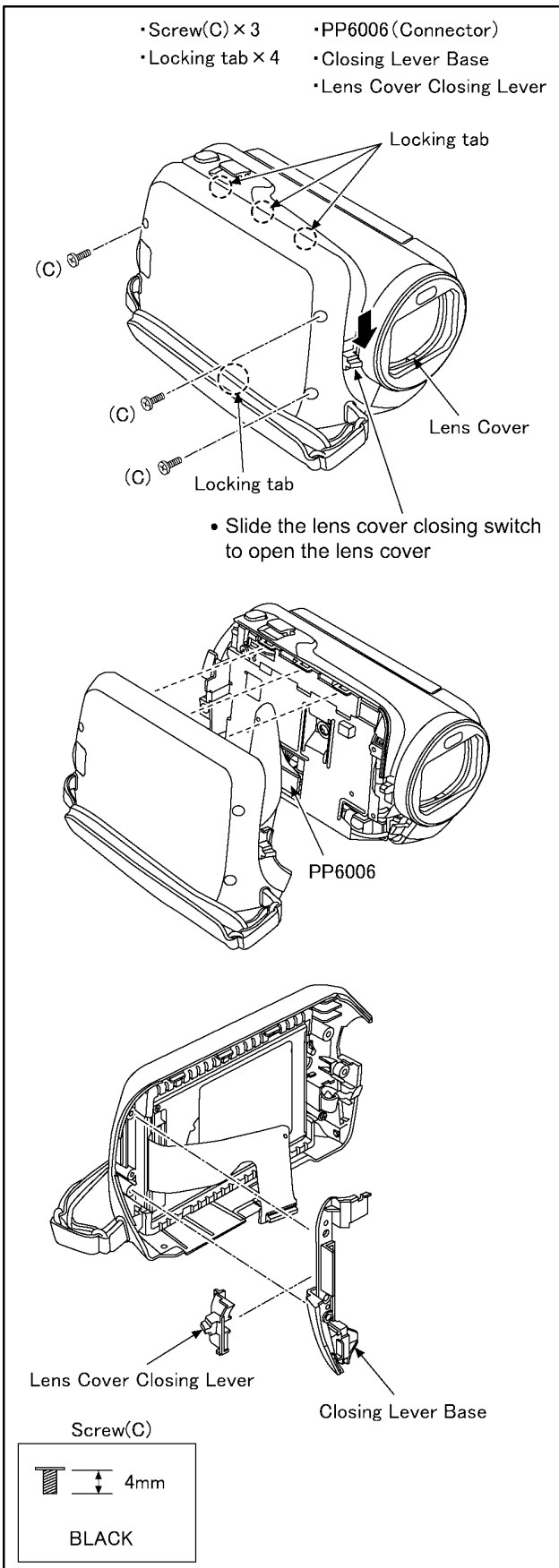

(Fig. D2)

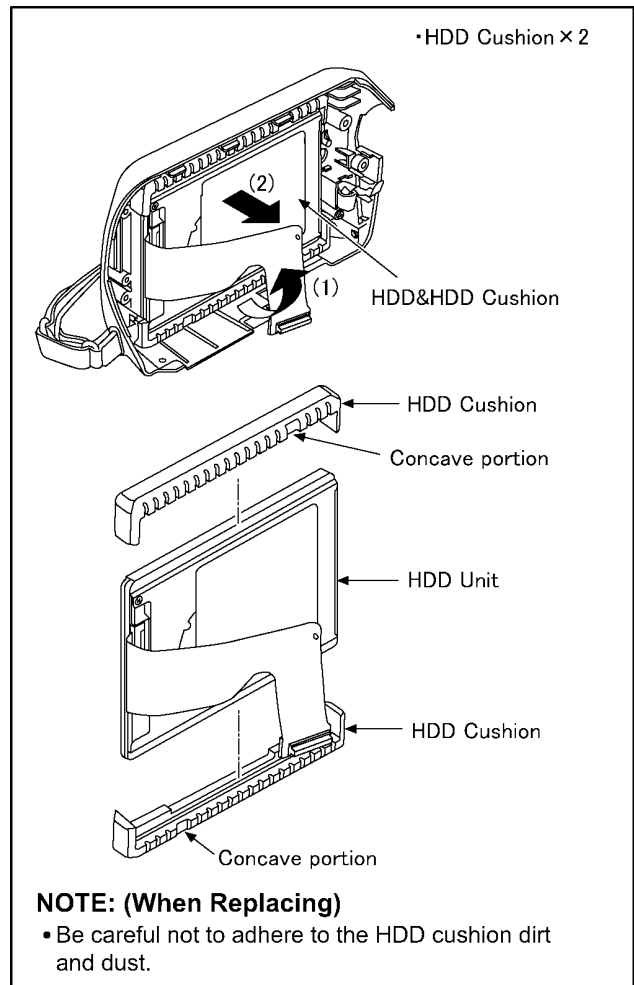

(Fig. D3)

8.3.2. Removal of the Top Case Unit

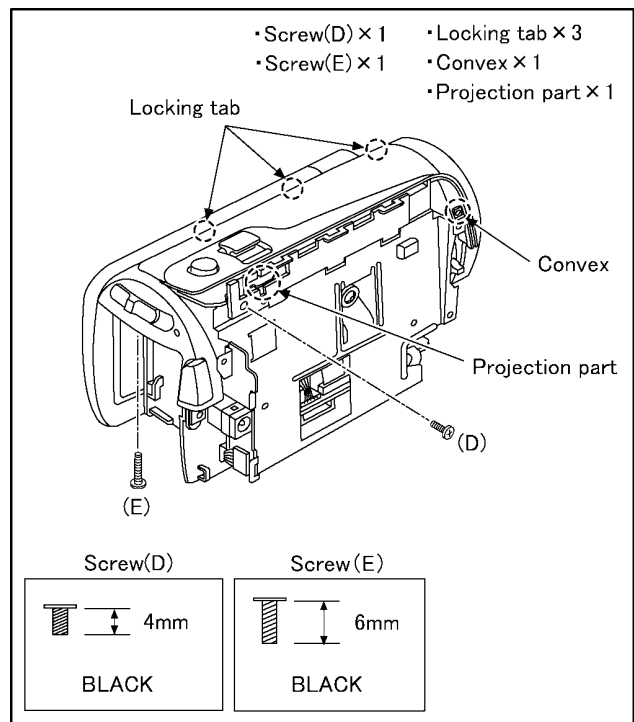

(Fig. D4)

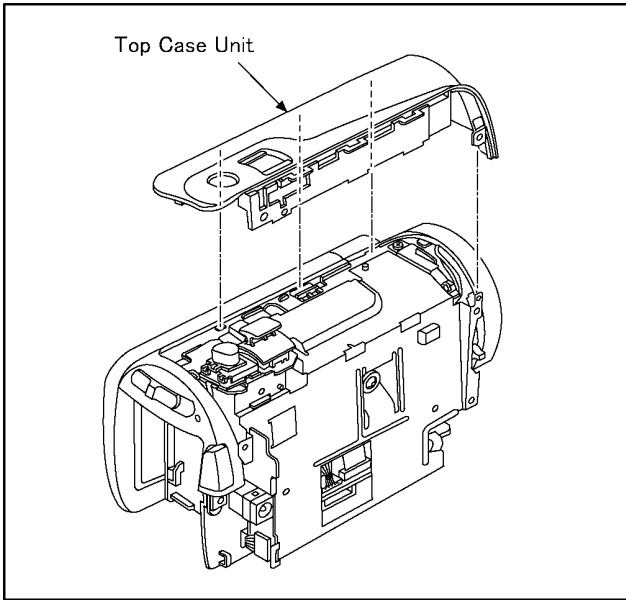

(Fig. D5)

8.3.3. Removal of the HDD Frame and DC Jack P.C.B.

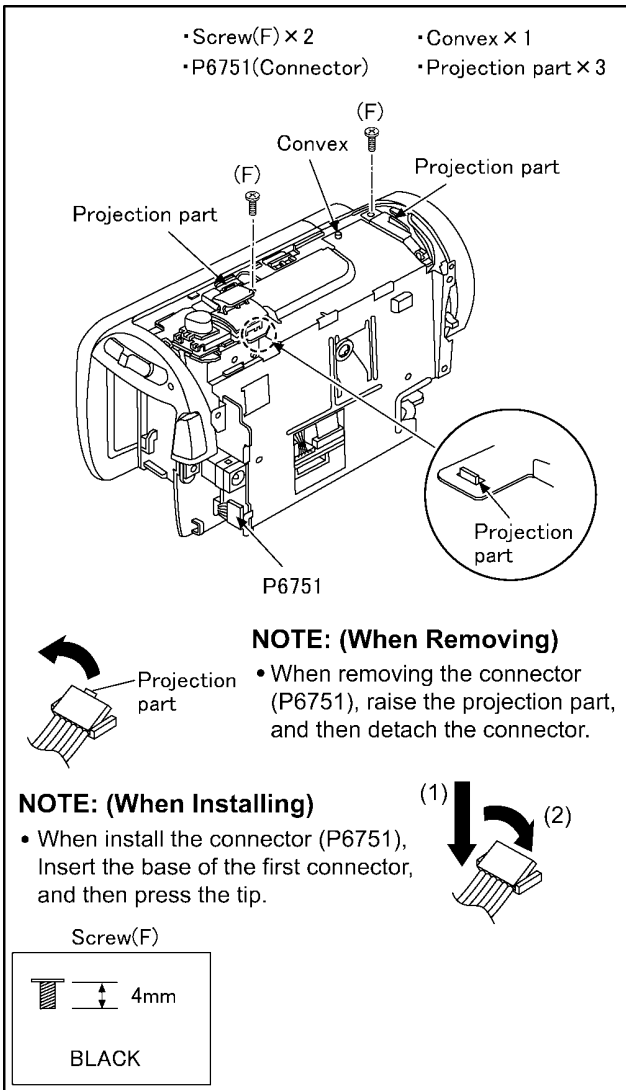

(Fig. D6)

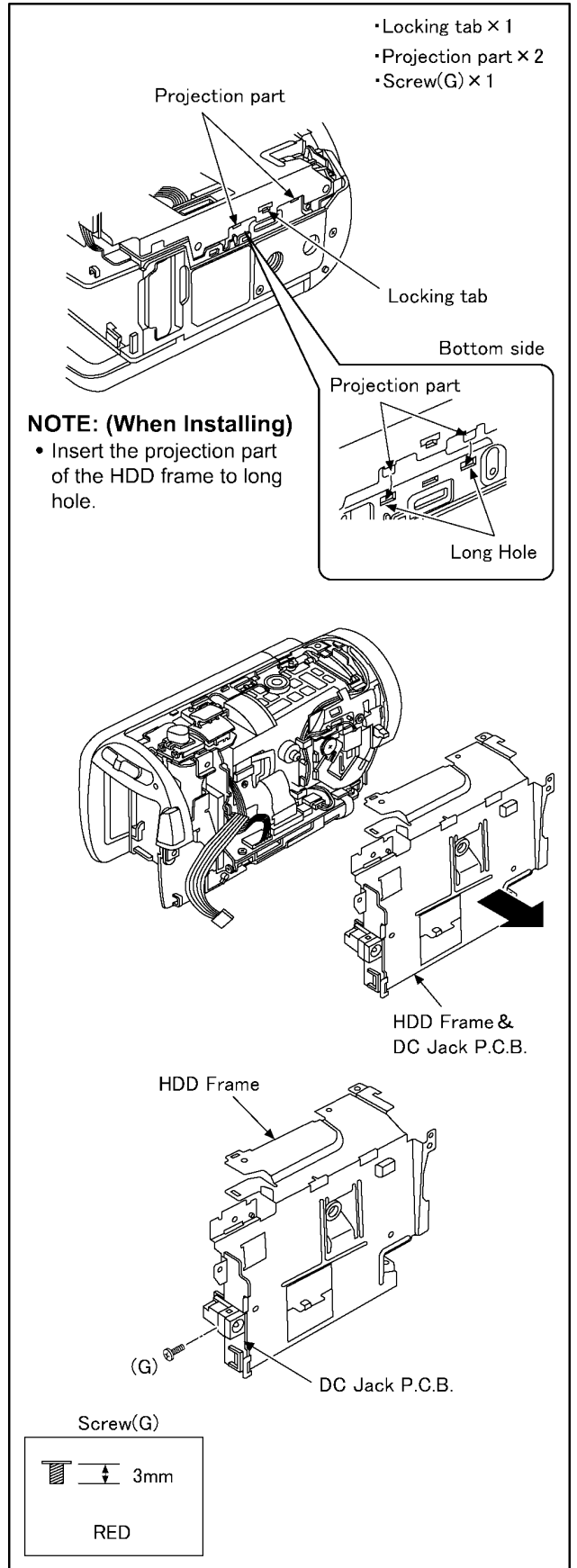

(Fig. D7)

8.3.4. Removal of the Front Case Unit

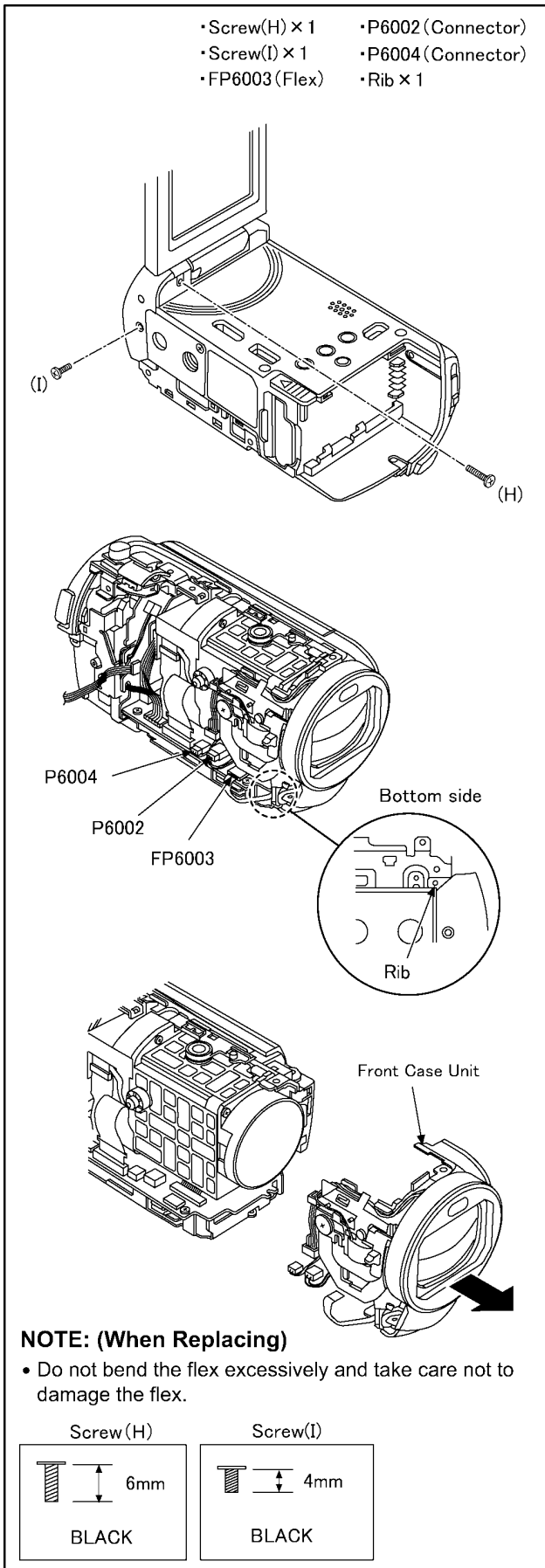

(Fig. D8)

8.3.5. Removal of the Camera Lens Unit

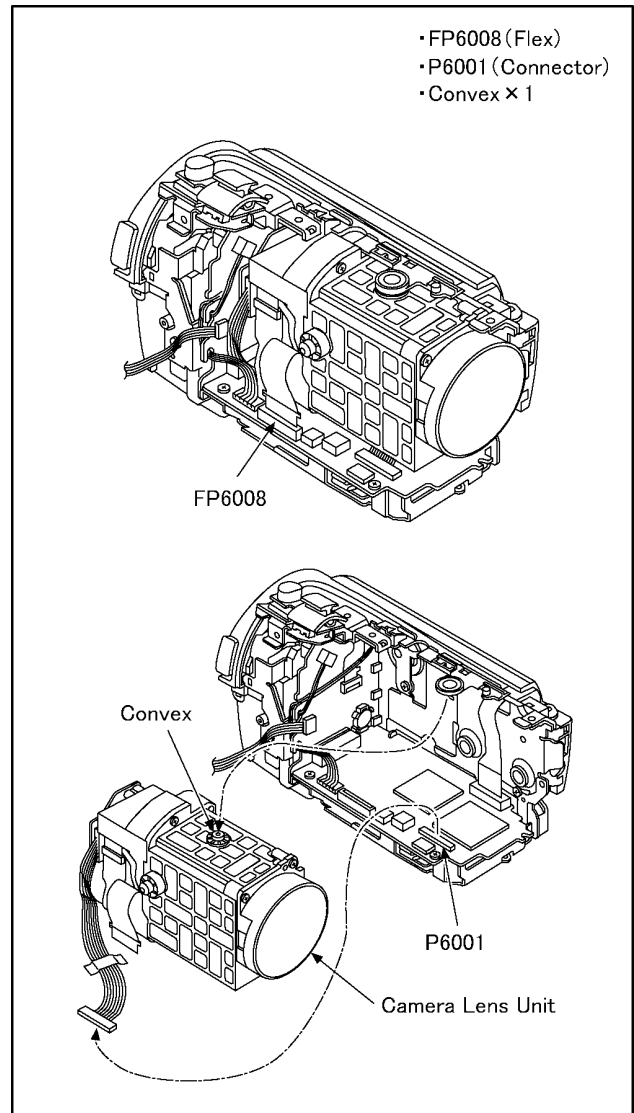

(Fig. D9)

8.3.6. Removal of the Main P.C.B. and SD Holder P.C.B.

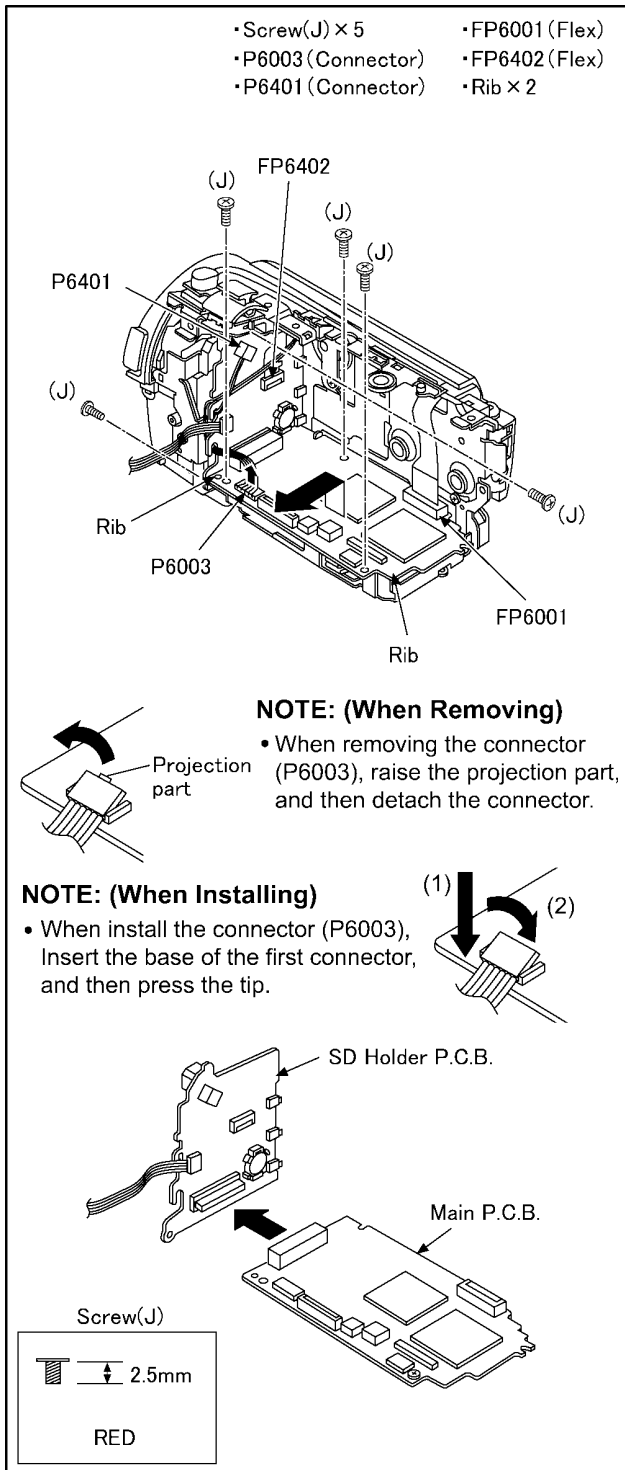

(Fig. D10)

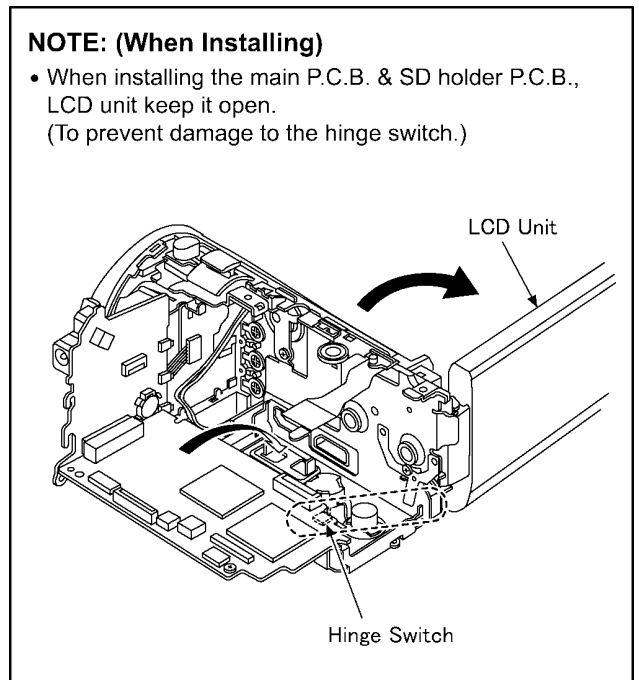

(Fig. D11)

8.3.7. Removal of the Battery P.C.B.

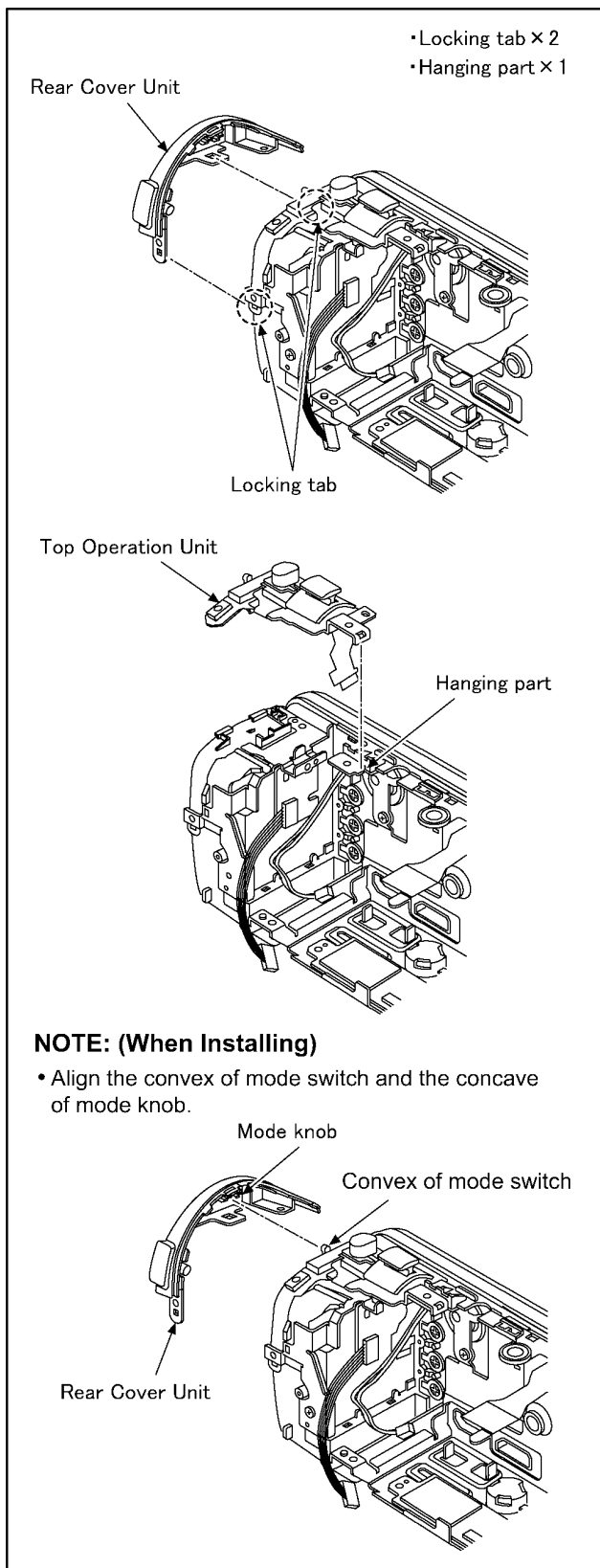

(Fig. D12)

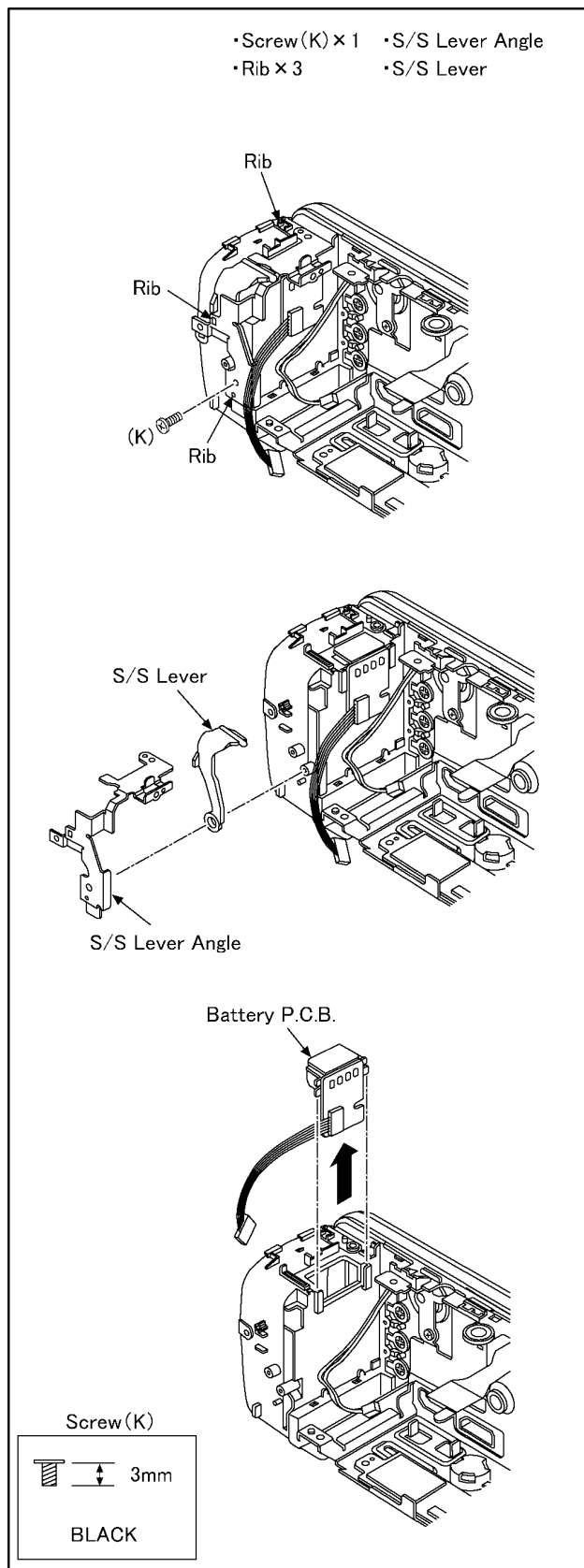

(Fig. D13)

9 Measurements and Adjustments

9.1. Electric Adjustment

- Adjustment method is different from a conventional High definition video camera.
- An exclusive jig and PC (including software for adjustment "Tatsujin") are necessary for electric adjustment.
- A USB driver for service is necessary to communication with PC.
- Connection method of the main unit and an exclusive adjustment jig as follows

9.1.1. Adjustment Procedure

- Connect the main unit to PC with USB.
The adjustment instruction is available at "Software download" on the "Support Information from NWBG/VDBG-AVC" web-site in "TSN System".

Figure of connection

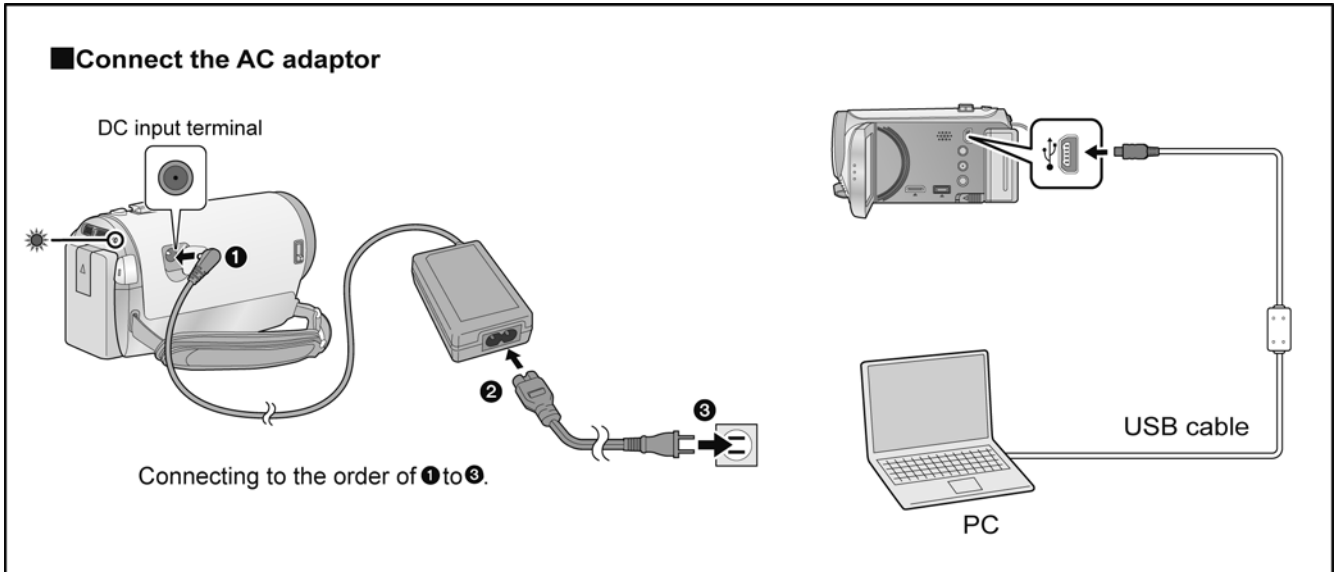
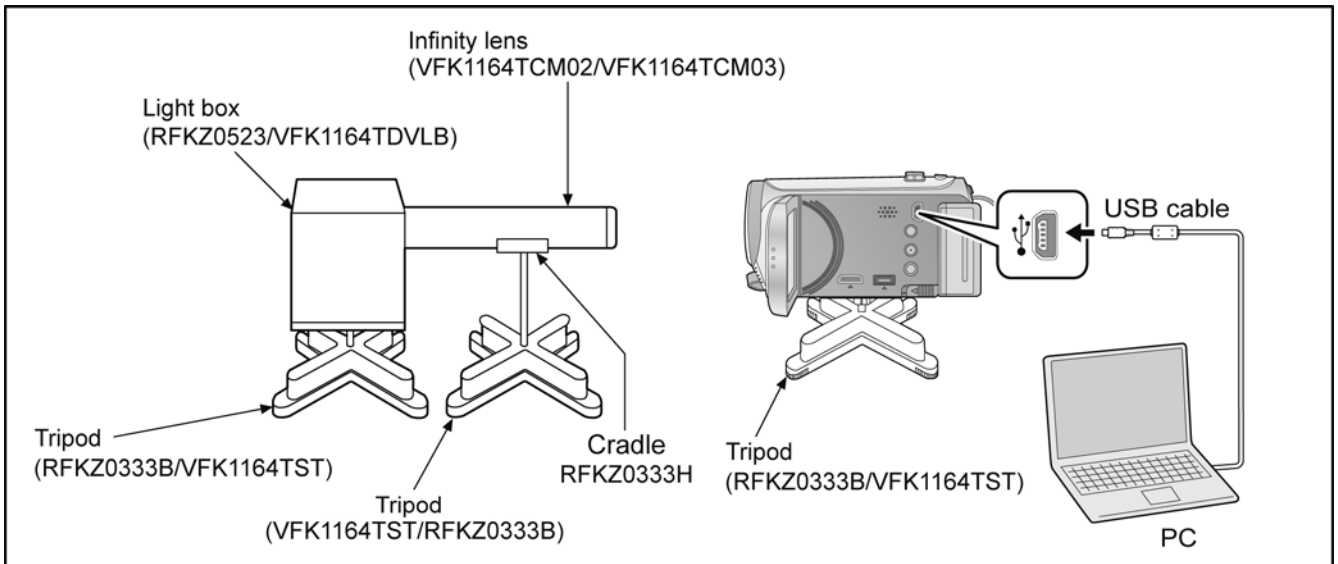

Figure of image when adjustment



Part Number of jig

- Only a necessary jig mentions it in setup of electric adjustment.

| No. | Part Name | Part Number | Remarks |
|-----|--------------------------------|-------------|---------|
| 1 | PC | ----- | |
| 2 | AC Adaptor | ----- | |
| 3 | USB Cable | ----- | |
| 4 | Adjustment Software (Tatsujin) | ----- | |

Adjustment Items

- Adjustment item as follows.

The adjustment instruction is available at "Software download" on the "Support Information from NWBG/VDBG-AVC" web-site in "TSN System".

| | Replacement part | | Main P.C.B. | IC2002(EEPROM) | Lens Unit | MOS Unit | IC3701 | IC3401, IC3402 | IC701 | IC6401 |
|-------------|---|-----------------------|-----------------------|-----------------------|-----------------------|----------|-----------------------|-----------------------|-----------------------|-----------------------|
| | Adjustment item | | | | | | | | | |
| Camera Part | ● Hall amplifire/PWM bias/ OIS Hall amplifire adjustment (automatic) | <input type="radio"/> | <input type="radio"/> | <input type="radio"/> | <input type="radio"/> | | | | <input type="radio"/> | <input type="radio"/> |
| | ● OIS Sensor Offset adjustment (automatic) | <input type="radio"/> | <input type="radio"/> | | | | | | | <input type="radio"/> |
| | ● Zoom tracking adjustment (automatic) | <input type="radio"/> | <input type="radio"/> | <input type="radio"/> | <input type="radio"/> | | | | <input type="radio"/> | |
| | ● Address wound revision (automatic) | <input type="radio"/> | <input type="radio"/> | | <input type="radio"/> | | | | | |
| | ● White balance adjustment (automatic) | <input type="radio"/> | <input type="radio"/> | | <input type="radio"/> | | | | | |
| | ● Gain adjustment between channels (automatic) | <input type="radio"/> | <input type="radio"/> | | <input type="radio"/> | | | | | |
| Video Part | ● Brightness level adjustment (automatic) | <input type="radio"/> | <input type="radio"/> | | | | <input type="radio"/> | | | |
| | ● UniPhier DDR revision (automatic) | <input type="radio"/> | <input type="radio"/> | | | | | <input type="radio"/> | | |

10 Factory Setting

10.1. How To Turn On The Factory Settings?

1. Set the mode switch "Motion Picture Recording" mode.
2. While the power is turned OFF, keep pressing the "Power" button, "Zoom lever" to W side and "intelligent auto/Manual" button for more than 3 seconds until the top screen of the Service Mode Menu being displayed.

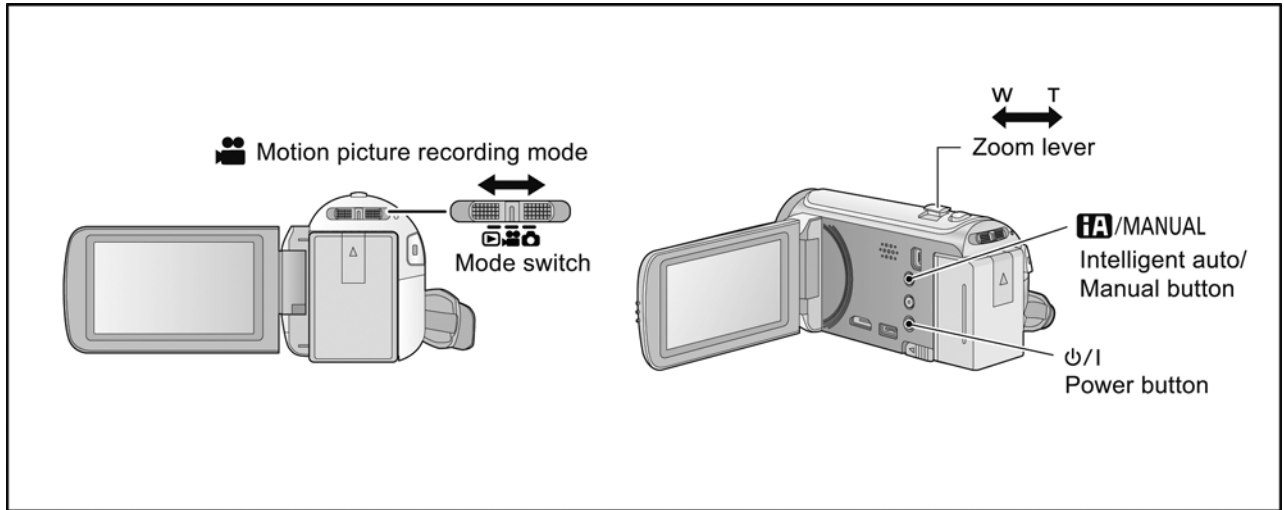

3. Touch the [1] of LCD.
4. Touch the [YES] of LCD.
5. After few seconds "END" is displayed or "HDD NODATA" as "NG" is displayed on LCD monitor. Cutting of battery connection or AC power supply connection as a completion of the "FACTORY SETTINGS".
(After use at least once, even if the physical format of the HDD unit will be performed, "HDD NODATA" as "NG" is indicated, but "FACTORY SETTINGS" is completed.)

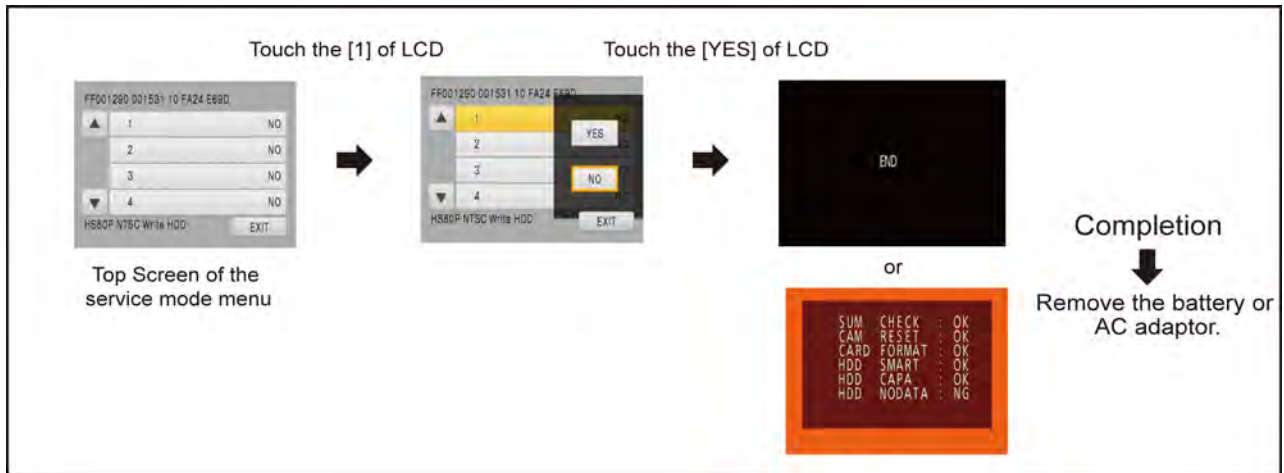

10.2. What Is The Factory Settings?

The factory settings clean up and/or refresh the following settings.

1. MENU, MODE, ADJUSTMENT VALUE.
2. SD card format.
3. Reset the folder number and file number of still pictures.
(Setting the folder number is 100, and file number is 0.)
4. Clear the mechanism lock information.
5. Clear the service mode information contents.
6. Close the lens cover
7. Initialize the VIERA Link Physical Address.

If the "Factory Settings" is completed, physical format of the HDD unit is not performed, execute physical format according to the following procedure.

To physically format the HDD, connect the unit via the AC adaptor, select [SETUP] → [FORMAT MEDIA] → [HDD] from the menu, and then press and hold the recording start/stop button on the screen below for about 3 seconds. When the HDD data deletion screen appears, select [YES], and then follow the on-screen instructions:



The setting position of factory settings:

| Name | Setting position |
|-------------|-------------------------------|
| Mode switch | Motion picture recording mode |

Service Manual

Diagrams and Replacement Parts List

High Definition Video Camera

Model No.

| | |
|------------|------------|
| HDC-HS80P | HDC-HS80GA |
| HDC-HS80PC | HDC-HS80GC |
| HDC-HS80PU | HDC-HS80GN |
| HDC-HS80EB | HDC-HS80GT |
| HDC-HS80EC | HDC-HS80GK |
| HDC-HS80EE | |
| HDC-HS80EG | |
| HDC-HS80EP | |

Vol. 1
 Colour
 (K).....Black Type

Table of contents

| | |
|--|------|
| S1. About Indication of The Schematic Diagram..... | S-1 |
| S1.1. Important Safety Notice..... | S-1 |
| S2. Voltage Chart | S-2 |
| S2.1. SD P.C.B. | S-2 |
| S3. Block Diagram..... | S-3 |
| S3.1. Overall Block Diagram | S-3 |
| S4. Schematic Diagram..... | S-4 |
| S4.1. Interconnection Diagram..... | S-4 |
| S4.2. SD Schematic Diagram..... | S-5 |
| S5. Print Circuit Board..... | S-6 |
| S5.1. SD P.C.B. | S-6 |
| S6. Replacement Parts List..... | S-7 |
| S7. Exploded View | S-11 |
| S7.1. Frame and Casing Section..... | S-11 |
| S7.2. Packing Parts and Accessories Section..... | S-12 |

S1. About Indication of The Schematic Diagram

S1.1. Important Safety Notice

COMPONENTS IDENTIFIED WITH THE MARK \triangle HAVE THE SPECIAL CHARACTERISTICS FOR SAFETY. WHEN REPLACING ANY OF THESE COMPONENTS USE ONLY THE SAME TYPE.

1. Although reference number of the parts is indicated on the P.C.B. drawing and/or schematic diagrams, it is NOT mounted on the P.C.B. when it is displayed with "\$" mark.
2. It is only the "Test Round" and no terminal (Pin) is available on the P.C.B. when the TP (Test Point) indicated as "●" mark.
3. The voltage being indicated on the schematic diagram is measured in "Standard-Playback" mode when there is no specify mode is mentioned.
4. Although the voltage and waveform available on here is measured with standard frame, it may be differ from actual measurement due to modification of circuit and so on.
5. The voltage being indicated here may be include observational-error (deviation) due to internal-resistance and/or reactance of equipment. Therefore, handle the value indicated on here as reference.
6. Use the parts number indicated on the Replacement Parts List .
7. Indication on Schematic diagrams:

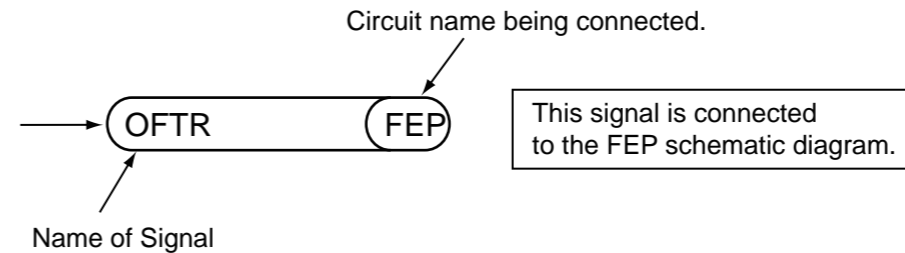

S2. Voltage Chart

Note) Indicated voltage values are the standard values for the unit measured by the DC electronic circuit tester (high-impedance) with the chassis taken as standard.
Therefore, there may exist some errors in the voltage values, depending on the internal impedance of the DC circuit tester.

S2.1. SD P.C.B.

| REF No. | PIN No. | POWER ON |
|---------|---------|----------|
| Q3901 | E | 3.3 |
| Q3901 | C | 0 |
| Q3901 | B | 3.3 |
| QR6401 | E | 2.9 |
| QR6401 | C | -0.4 |
| QR6401 | B | 2.9 |
| QR6402 | E | 2.9 |
| QR6402 | C | -0.4 |
| QR6402 | B | 2.9 |

S3. Block Diagram

S3.1. Overall Block Diagram

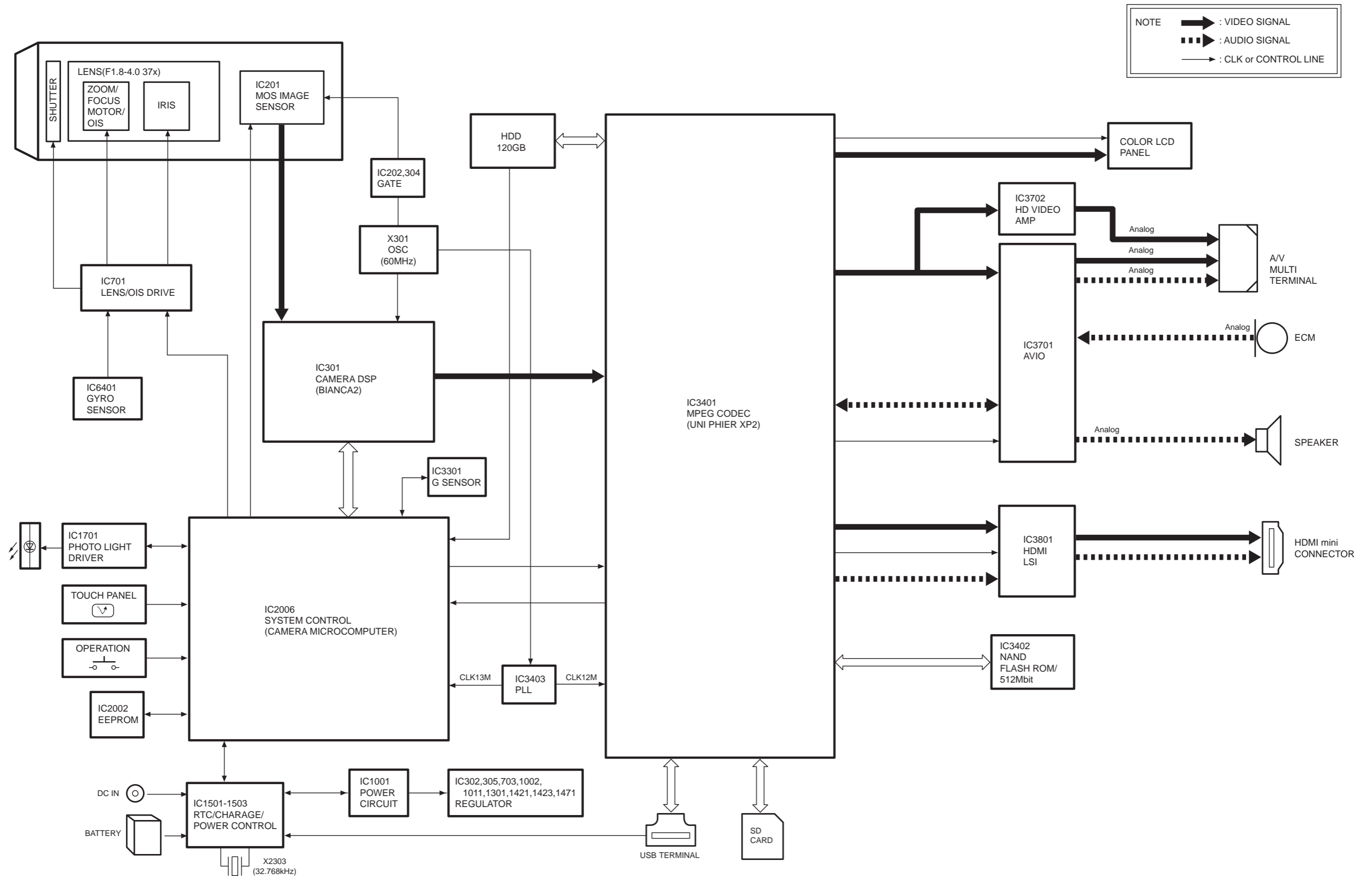

S4. Schematic Diagram

S4.1. Interconnection Diagram

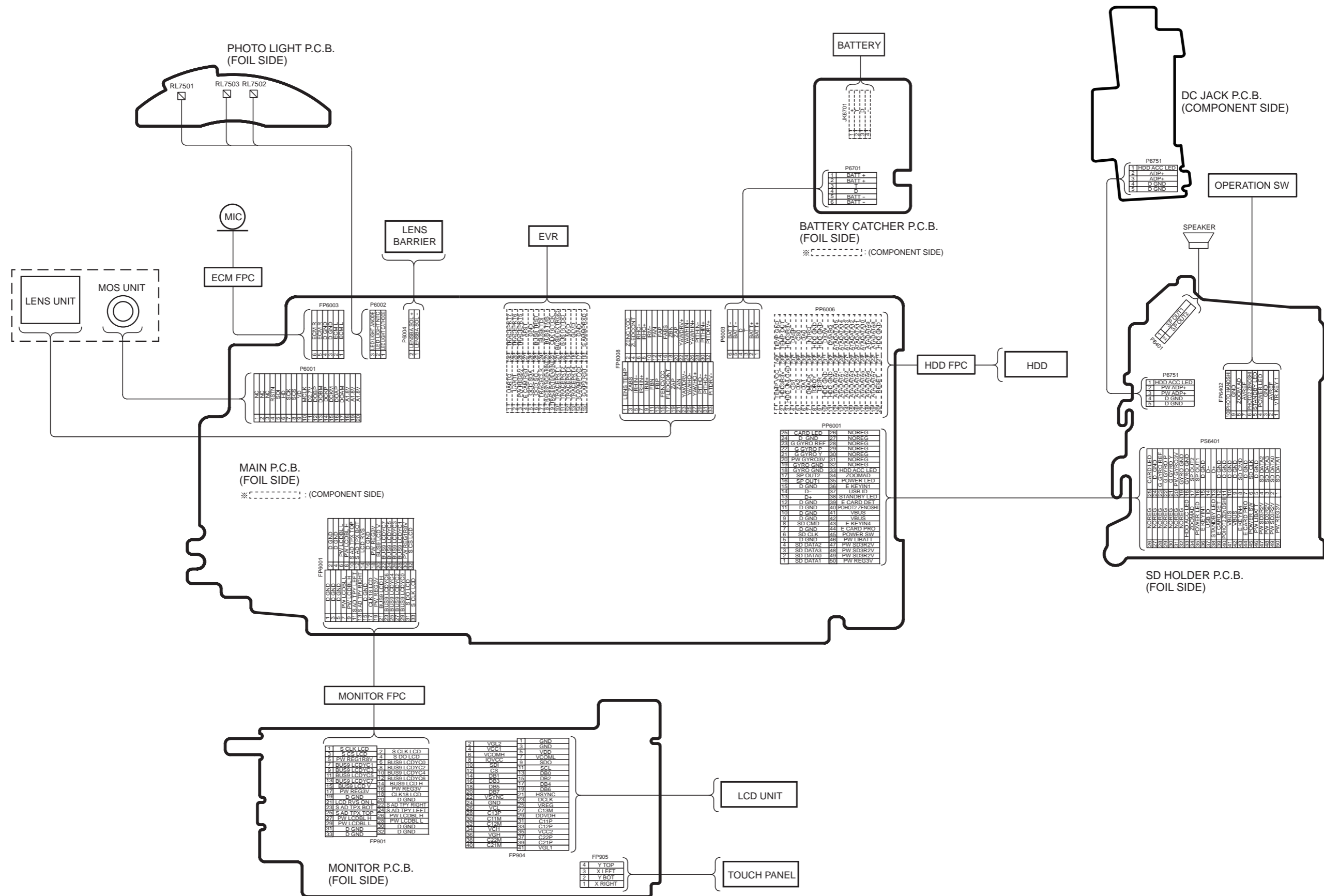

S4.2. SD Schematic Diagram

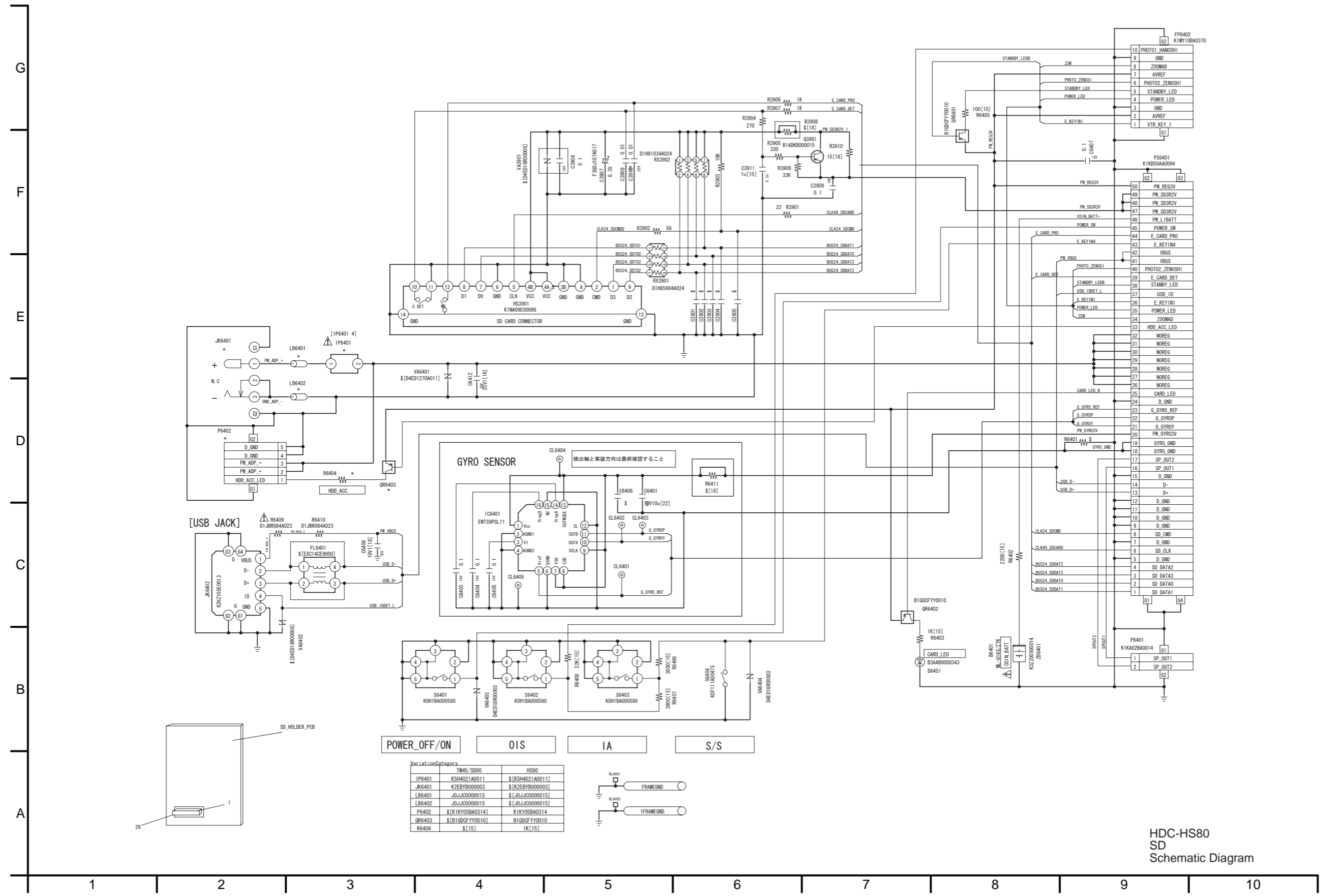

HDC-HS80
SD
Schematic Diagram

S5. Print Circuit Board

S5.1. SD P.C.B.

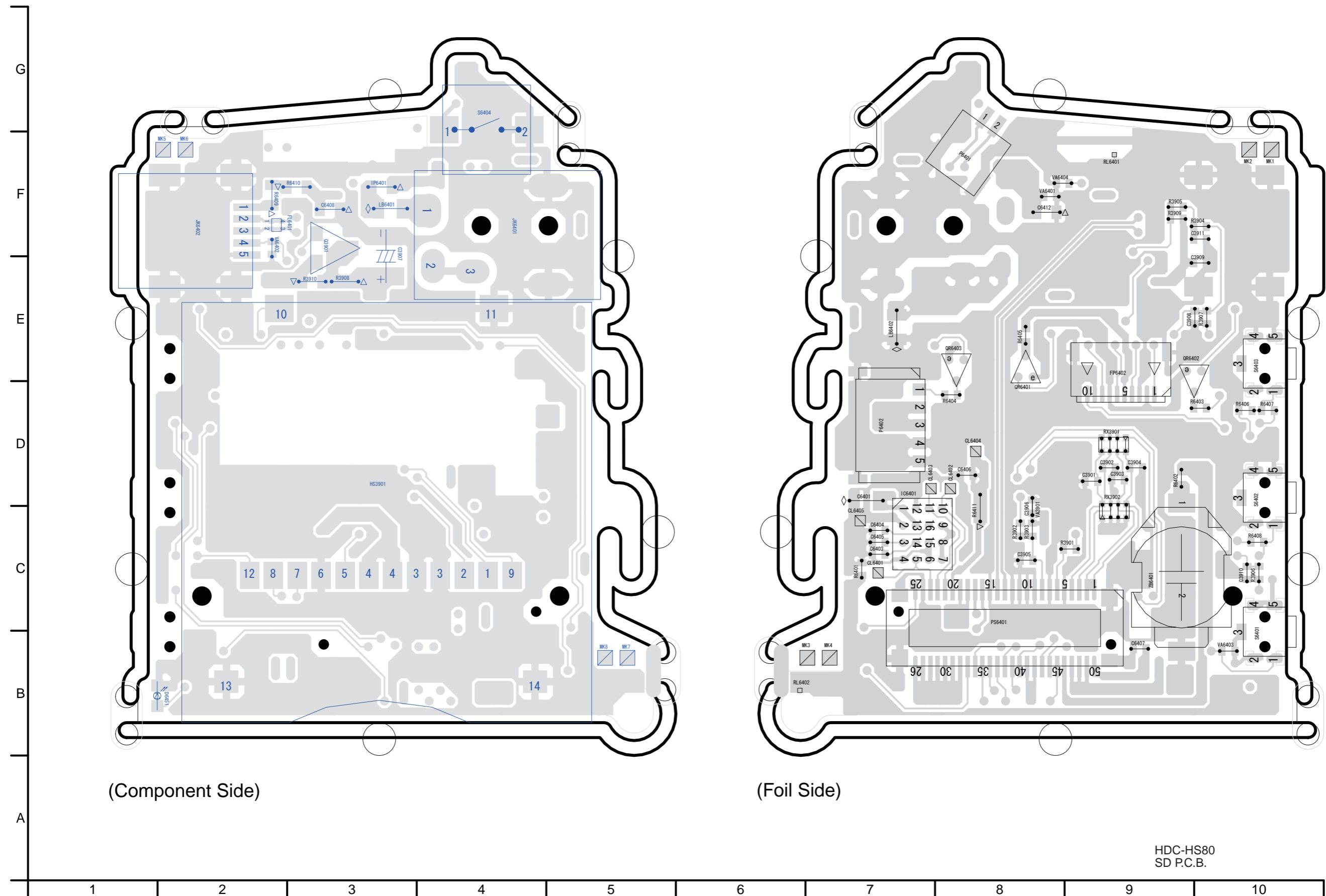

(Component Side)

(Foil Side)

HDC-HS80
SD P.C.B.

S6. Replacement Parts List

- Note: 1.* Be sure to make your orders of replacement parts according to this list.
2. IMPORTANT SAFETY NOTICE
Components identified with the mark \triangle have the special characteristics for safety.
When replacing any of these components, use only the same type.
3. Unless otherwise specified,
All resistors are in OHMS, K=1,000 OHMS. All capacitors are in MICRO-FARADS (uf), P=uuF.
4. The marking (RTL) indicates the retention time is limited for this item. After the discontinuation of this assembly in production, it will no longer be available.

E.S.D. standards for Electrostatically Sensitive Devices, refer to “PREVENTION OF ELECTROSTATIC DISCHARGE (ESD) TO ELECTROSTATICALLY SENSITIVE (ES) DEVICES” section.

| Ref.No. | Part No. | Part Name & Description | Pcs | Remarks |
|---------|--------------|--------------------------|-----|--------------------------------|
| ## | VEP03J12CP | MAIN P.C.B. UNIT | 1 | (RTL) E.S.D. EB,EC,EG,EP |
| ## | VEP03J12CQ | MAIN P.C.B. UNIT | 1 | (RTL) E.S.D. EE,GC,GK,GN,GA |
| ## | VEP03J12CN | MAIN P.C.B. UNIT | 1 | (RTL) E.S.D. GT,P,PC,PU |
| ## | VEP03J16B | SD HOLDER P.C.B. UNIT | 1 | (RTL) E.S.D. |
| ## | VEP79298A | HDD FPC UNIT | 1 | |
| ## | VEP03J16B | SD HOLDER P.C.B. UNIT | 1 | (RTL) E.S.D. |
| △ B6401 | ML-614S/ZTK | BATTERY | 1 | [ENERGY] |
| C3906 | F1G1C104A077 | C.CAPACITOR CH 16V 0.1U | 1 | |
| C3907 | F3G0J107A017 | C.CAPACITOR CH 6.3V 100U | 1 | |
| C3908 | F1G1E1030005 | C.CAPACITOR CH 25V 0.01U | 1 | |
| C3909 | F1G1C104A077 | C.CAPACITOR CH 16V 0.1U | 1 | |
| C3910 | F1G1E1030005 | C.CAPACITOR CH 25V 0.01U | 1 | |
| C3911 | F1G0J1050007 | C.CAPACITOR CH 6.3V 1U | 1 | |
| C6401 | F1J1A106A043 | C.CAPACITOR CH 10V 10U | 1 | |
| C6403 | F1G1C104A077 | C.CAPACITOR CH 16V 0.1U | 1 | |
| C6404 | F1G1C104A077 | C.CAPACITOR CH 16V 0.1U | 1 | |
| C6405 | F1G1C104A077 | C.CAPACITOR CH 16V 0.1U | 1 | |
| C6407 | F1G1C104A077 | C.CAPACITOR CH 16V 0.1U | 1 | |
| C6408 | ECJ1VB1A105K | C.CAPACITOR CH 10V 1U | 1 | |
| C6412 | F1H1E105A116 | C.CAPACITOR CH 25V 1U | 1 | |
| D6451 | B3AAB0000343 | LED | 1 | E.S.D. |
| FP6402 | K1MY10BA0370 | CONNECTOR 10P | 1 | |
| HS3901 | K1NA09E00098 | SD CARD SLOT | 1 | |
| IC6401 | EWTS9PSL11 | IC | 1 | E.S.D. |
| JK6402 | K2HZ105E0013 | JK, USB | 1 | |
| P6401 | K1KA02BA0014 | CONNECTOR 2P | 1 | |
| P6402 | K1KY05BA0314 | CONNECTOR 5P | 1 | |
| PS6401 | K1KB50AA0094 | CONNECTOR 50P | 1 | |
| Q3901 | B1ADKB000015 | TRANSISTOR | 1 | E.S.D. |
| QR6401 | B1GDCFYY0010 | TRANSISTOR | 1 | E.S.D. |
| QR6402 | B1GDCFYY0010 | TRANSISTOR | 1 | E.S.D. |
| QR6403 | B1GDCFYY0010 | TRANSISTOR | 1 | E.S.D. |
| R3901 | ERJ2GEJ470 | M.RESISTOR CH 1/16W 47 | 1 | |
| R3902 | ERJ2GEJ560X | M.RESISTOR CH 1/10W 56 | 1 | |
| R3903 | ERJ2GEJ103 | M.RESISTOR CH 1/10W 10K | 1 | |
| R3904 | ERJ2GEJ271 | M.RESISTOR CH 1/10W 270 | 1 | |
| R3905 | ERJ2GEJ331 | M.RESISTOR CH 1/16W 330 | 1 | |
| R3906 | ERJ2GEJ102Y | M.RESISTOR CH 1/10W 1K | 1 | |
| R3907 | ERJ2GEJ102Y | M.RESISTOR CH 1/10W 1K | 1 | |
| R3909 | ERJ2GEJ333 | M.RESISTOR CH 1/16W 33K | 1 | |
| R3910 | D0GB150JA057 | M.RESISTOR CH 1/10W 15 | 1 | |
| R6402 | ERJ2GEJ222 | M.RESISTOR CH 1/10W 2.2K | 1 | |
| R6403 | ERJ2GEJ102Y | M.RESISTOR CH 1/10W 1K | 1 | |
| R6404 | ERJ2GEJ102Y | M.RESISTOR CH 1/10W 1K | 1 | |
| R6405 | ERJ2GEJ101 | M.RESISTOR CH 1/10W 100 | 1 | |
| R6406 | ERJ2GEJ302 | M.RESISTOR CH 1/16W 3K | 1 | |
| R6407 | ERJ2GEJ392 | M.RESISTOR CH 1/10W 3.9K | 1 | |
| R6408 | ERJ2GEJ223 | M.RESISTOR CH 1/16W 22K | 1 | |
| △ R6409 | D1JBR084A023 | FUSE RESISTOR | 1 | |
| R6410 | ERJ3GEY0R00 | M.RESISTOR CH 1/10W 0 | 1 | |
| RX3901 | D1H85604A024 | RESISTOR NETWORKS | 1 | |
| RX3902 | EXB28V103JX | RESISTOR NETWORKS | 1 | |
| S6401 | K0H1BA000580 | SWITCH | 1 | |
| S6402 | K0H1BA000580 | SWITCH | 1 | |
| S6403 | K0H1BA000580 | SWITCH | 1 | |
| S6404 | K0F111A00475 | SWITCH | 1 | |
| VA6403 | D4ED18R00003 | VARISTOR | 1 | |

| Ref.No. | Part No. | Part Name & Description | Pcs | Remarks |
|---------|--------------|-------------------------|-----|---------|
| VA6404 | D4ED18R00003 | VARISTOR | 1 | |
| ZB6401 | K3Z200500014 | BATTERY HOLDER | 1 | |
| ## | VEP79298A | HDD FPC UNIT | 1 | |
| PS6201 | K1KB40A00128 | CONNECTOR 40P | 1 | |

S7. Exploded View

S7.1. Frame and Casing Section

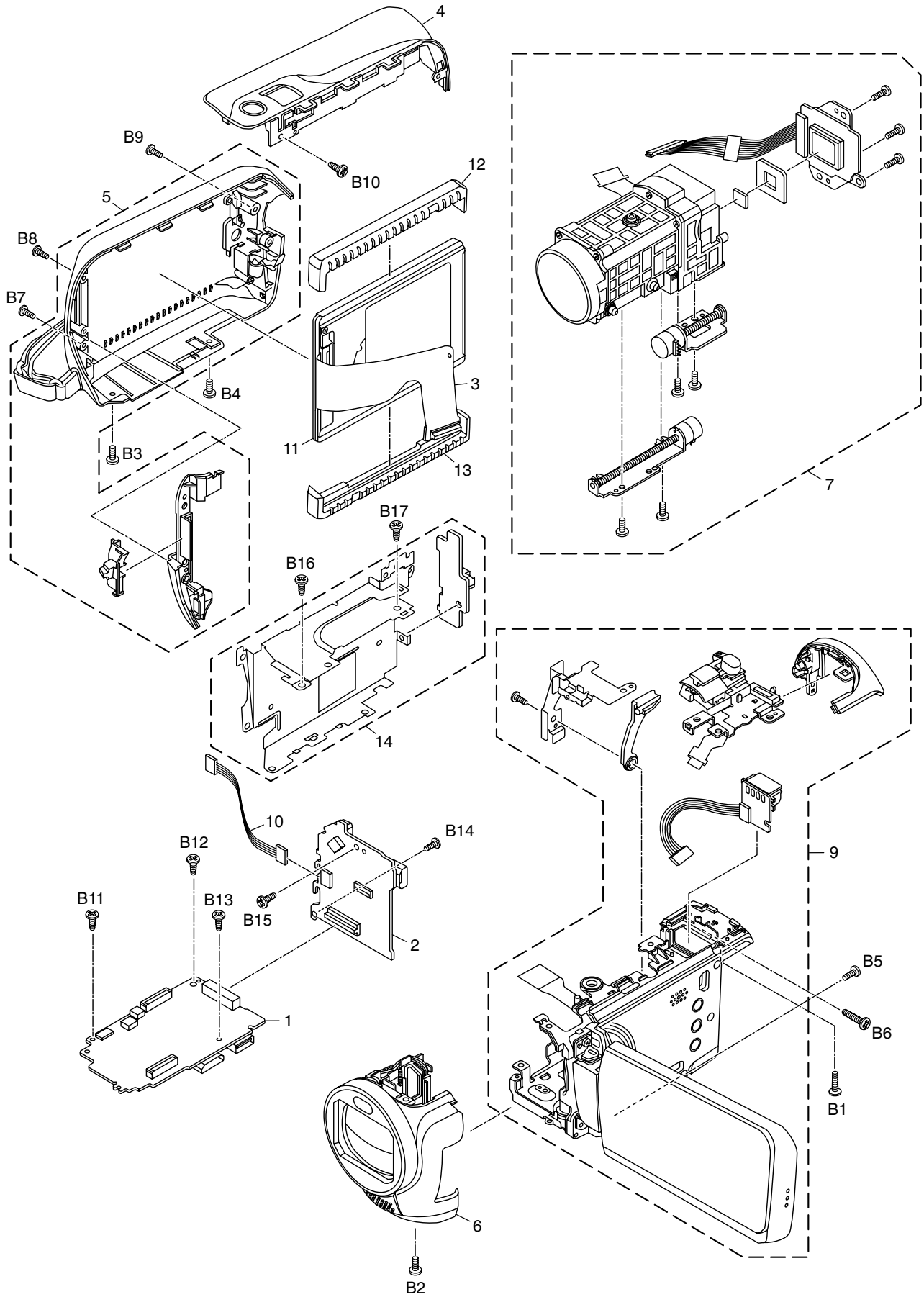

S7.2. Packing Parts and Accessories Section

